

LA-UR-08-5852
September 2008
EP2008-0450

Pajarito Canyon Investigation Report

Prepared by the Environmental Programs Directorate

Los Alamos National Laboratory, operated by Los Alamos National Security, LLC, for the U.S. Department of Energy under Contract No. DE-AC52-06NA25396, has prepared this document pursuant to the Compliance Order on Consent, signed March 1, 2005. The Compliance Order on Consent contains requirements for the investigation and cleanup, including corrective action, of contamination at Los Alamos National Laboratory. The U.S. government has rights to use, reproduce, and distribute this document. The public may copy and use this document without charge, provided that this notice and any statement of authorship are reproduced on all copies.

Pajarito Canyon Investigation Report

September 2008

Responsible project leader:

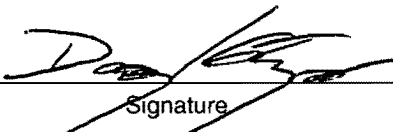
Danny Katzman		Project Leader	Environmental Programs	9.29.08
Printed Name	Signature	Title	Organization	Date

Responsible LANS representative:

Susan G. Stiger		Associate Director	Environmental Programs	9/29/08
Printed Name	Signature	Title	Organization	Date

Responsible DOE representative:

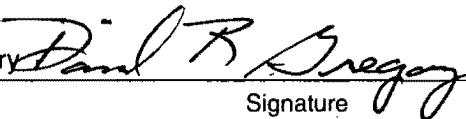
David R. Gregory		Project Director	DOE-LASO	9/29/08
Printed Name	Signature	Title	Organization	Date

EXECUTIVE SUMMARY

This investigation report for Pajarito Canyon presents the results of studies conducted from 2000 to 2008 in Pajarito, Threemile, and Twomile Canyons and their tributaries in and near Los Alamos National Laboratory (the Laboratory). Together these drainage systems comprise the Pajarito watershed. These canyons have received inorganic and organic chemicals and radionuclides since the Laboratory was established in 1943. Most of the contamination related to Laboratory releases is associated with either effluent discharges or open-air tests, and releases of contaminants have decreased over time. The investigations reported herein address sediment, surface water, groundwater, and biota potentially impacted by solid waste management units (SWMUs) and areas of concern (AOCs) located within the watershed. Investigations occurred along 35 km (22 mi) of canyon bottom downcanyon of SWMUs or AOCs. The objectives of the investigations included defining the nature and extent of chemicals of potential concern (COPCs) in sediment, surface water, and groundwater and assessing the potential risks to human health and the environment from these COPCs. The investigations also address the sources, fate, and transport of COPCs in the canyons and evaluate the need for additional characterization or remedial actions.

The results of this investigation indicate that human health risks are acceptable for present-day and foreseeable future land uses. In addition, no adverse ecological effects were observed within terrestrial and aquatic systems in the Pajarito watershed. Therefore, corrective actions are not needed to mitigate unacceptable risks. However, additional monitoring of sediment, surface water, groundwater, and cavity-nesting birds and their food is recommended.

Sediment investigations included geomorphic mapping, associated geomorphic characterization, and sediment sampling in 29 investigation reaches located downcanyon from SWMUs or AOCs and 3 reaches located upcanyon from SWMUs and AOCs.

Surface-water investigations included evaluation of analytical data from samples collected at 15 locations along stream channels and 12 springs. These are locations where water potentially occurs persistently enough to support an evaluation of human health risks.

Groundwater investigations included evaluation of analytical data from samples at 18 alluvial wells, 5 intermediate groundwater wells, and 7 regional groundwater wells within the Pajarito watershed. Groundwater investigations also included surface and subsurface geophysical surveys, water-level measurements, analyses of core samples and vadose-zone pore water, and evaluation of analytical data from springs.

Sediment COPCs in the Pajarito watershed include 26 inorganic chemicals, 103 organic chemicals, and 11 radionuclides. These COPCs are derived from a variety of sources, including Laboratory SWMUs and AOCs, runoff from developed areas, ash from the area burned in the May 2000 Cerro Grande fire, and natural sources such as noncontaminated soil, sediment, and bedrock. Assessments in this report focus on the subset of sediment COPCs considered most important for the evaluation of potential ecological or human health risk. The relative importance of the COPCs was determined by comparing COPC concentrations with human health residential screening action levels and soil screening levels and ecological screening levels.

The spatial distribution of sediment COPCs in the Pajarito watershed indicates that contaminants have been released and transported downcanyon from several Laboratory technical areas (TAs), including TA-03, TA-08, TA-09, TA-15, TA-22, TA-40, and TA-69. Contaminants in sediment that were released from these TAs are identifiable as COPCs for varying distances downcanyon from the sources. Some are COPCs only in reaches close to the sources, whereas others remain COPCs in the farthest downcanyon

reach, PA-5W below the community of White Rock, over 16 km (10 mi) from the sources. Transport of contaminants released from TAs in upper Pajarito Canyon above the confluence with Twomile Canyon increased after the May 2000 Cerro Grande fire and is associated with increased magnitude and frequency of floods and erosion of post-1942 sediment deposits along the main channels. Because the magnitude and frequency of floods generated in the Cerro Grande fire burn area have decreased as the watershed has recovered, this post-fire sediment transport has also decreased. However, monitoring of COPC concentrations transported in sediment should continue, particularly in fine-grained sediment deposited after large flood events that have the highest potential for erosion and downcanyon transport.

In groundwater, manganese; iron; mercury; ammonia; chloride; 1,4-dioxane; lead; arsenic; RDX; and phenol exceed regulatory standards infrequently and show no spatial distributions relative to known release sites. Nitrate, tritium, and perchlorate, the most mobile of the inorganic chemicals released in the watershed, and radionuclides are present above background levels but below regulatory standards in surface water, and in alluvial, perched intermediate, and/or regional groundwaters. Elevated nitrate chloride, sulfate, and tritium concentrations were also reported in vadose-zone pore water collected from core samples from boreholes. Localized contamination of RDX; 1,4-dioxane; and/or chlorinated solvents occurs at several intermediate-depth wells and springs and one regional aquifer well. The spatial distribution of COPCs indicates that TA-09, TA-18, and possibly TA-16 are the main sources of mobile contaminants in surface water and groundwater. In addition, a localized perched intermediate groundwater plume containing chlorinated solvents and other contaminants occurs at TA-03, SWMU 03-010(a), a former vacuum pump repair site that operated from 1950 to 1957.

Outfalls, septic systems, and surface releases primarily responsible for contaminants in surface water and groundwater are no longer active. Surface water and groundwater should continue to be monitored because contaminants in soils and alluvium and in bedrock media near the primary release sites continue to be secondary sources of contaminants to surface water and groundwater. Monitoring frequency and analyte suites will be specified in annual updates to the "Interim Facility-wide Groundwater Monitoring Plan" (IFGMP).

The configuration of wells in the existing monitoring network is considered sufficient to meet the groundwater monitoring objectives for the watershed for the most part. However, more work is needed to test the assumption that supply wells, in particular well PM-4, are adequately protected. Additional analyses of the capture zone of the water-supply wells near Pajarito Canyon are expected to constrain uncertainty regarding the influence of municipal pumping on groundwater flow directions. These analyses will utilize the spinner test that was recently performed at PM-2 and the new hydrogeologic and geochemical information collected at well R-40 and other new regional monitoring wells close by. In the meantime, protection of supply wells PM-2, PM-4, and PM-5 is ensured by continued monitoring directly in those wells.

The monitoring well network evaluation could be improved by using new monitoring and water-level data obtained from wells R-37, R-38, R-39, R-40, and R-41, which are currently being installed at or adjacent to TA-54. After the wells are installed, the monitoring well network efficiency may be reevaluated if an updated water table map indicates a groundwater flow direction different from the previous analysis. Flow and transport models supporting the network evaluation will also benefit from an updated geologic model of the area based on observations made at the newly installed wells.

A baseline ecological risk assessment conducted as part of this investigation evaluates the potential for adverse effects by assessing risks to insect-eating birds, plants, earthworms, aquatic invertebrates, and two threatened and endangered species: the Mexican spotted owl and the southwestern willow flycatcher. Multiple lines of evidence were used to evaluate potential adverse effects on these ecological receptors. Ecological effects data were collected using a cavity-nesting bird monitoring network, seedling

germination tests, earthworm mortality tests, and sediment toxicity tests. The assessment lines of evidence are augmented by spatial modeling of wildlife exposure. The weight of evidence that these investigations provide indicates that no adverse effects to terrestrial and aquatic receptors exist from COPCs in the Pajarito watershed. However, there is only a short period of record in the bird monitoring network in the Pajarito watershed, and few samples of eggs or insects from this network have been analyzed to evaluate potential bioaccumulation. Therefore, continued monitoring of the nest box network in the Pajarito watershed is recommended.

The site-specific human health risk assessment uses a trail-user exposure scenario to represent the present-day and reasonably foreseeable future land use in canyons throughout the Pajarito watershed. The assessment results indicate that for the trail-user scenario, no areas in the Pajarito watershed have contaminant concentrations greater than levels acceptable for noncarcinogens (hazard index of 1), or carcinogens (incremental cancer risk criterion of 1×10^{-5}), or radionuclides (target dose limit of 15 mrem/yr for sediment and 4 mrem/yr for water) in sediment or water.

CONTENTS

1.0	INTRODUCTION	1
1.1	Purpose and Scope	1
1.2	Organization of Investigation Report	2
1.3	Watershed Description	3
1.4	Current Land Use	3
2.0	BACKGROUND	4
2.1	Sources and History of Contaminant Releases.....	4
2.1.1	TA-03.....	4
2.1.2	TA-06, TA-22, TA-40, and former TA-07.....	4
2.1.3	TA-08, TA-09, TA-69, and former TA-23.....	4
2.1.4	Former TA-12.....	5
2.1.5	TA-15.....	5
2.1.6	TA-18.....	5
2.1.7	TA-36 and Former TA-27	6
2.1.8	TA-48.....	6
2.1.9	TA-54.....	6
2.1.10	TA-55.....	6
2.1.11	TA-59.....	6
2.1.12	TA-64.....	6
2.1.13	TA-66.....	7
2.1.14	Runoff from Developed Areas.....	7
2.1.15	Cerro Grande Fire	7
2.2	Contamination in Canyons Media.....	7
2.2.1	Environmental Surveillance Program.....	7
2.2.2	Ecology Group.....	8
2.2.3	Environmental Restoration Project.....	8
2.2.4	NMED and EPA.....	8
2.3	Remediation Activities	8
2.3.1	MDA M.....	8
2.3.2	TA-69 Incinerator Ash Pond.....	9
2.3.3	Erosion Control.....	9
3.0	SCOPE OF ACTIVITIES	9
3.1	Sediment Investigations	9
3.2	Surface-Water and Groundwater Investigations	10
3.2.1	Monitoring Well Installations	10
3.2.2	Surface Water, Springs, and Groundwater Sampling	11
3.2.3	Water-Level Measurements	12
3.2.4	Surface Geophysics	12
3.2.5	Characterization Core Holes	12
3.3	Biological Investigations	12
3.4	Deviations from Planned Activities	12

4.0	FIELD INVESTIGATIONS.....	13
4.1	Sediment.....	13
4.2	Surface Water and Groundwater.....	14
4.2.1	Monitoring Well Installations	14
4.2.2	Surface-Water and Groundwater Sampling	14
4.2.3	Water-Level Measurements	14
4.2.4	Surface Geophysics	15
4.2.5	Characterization Core Holes	15
4.3	Biota.....	15
5.0	REGULATORY CRITERIA	15
5.1	Regulatory Context.....	15
5.2	Human Health Screening Levels	17
5.3	Ecological Screening Levels.....	17
5.4	Water Quality Standards and Screening Levels.....	17
6.0	CANYONS CONTAMINATION.....	19
6.1	Data Preparation.....	19
6.2	Sediment COPCs	20
6.2.1	Identification of Sediment COPCs.....	20
6.2.2	Comparison of Sediment COPC Concentrations to Residential SSLs and SALs.....	20
6.3	Surface Water and Groundwater COPCs	21
6.3.1	Identification of Surface Water and Groundwater COPCs.....	21
6.3.2	Comparison of Water COPC Concentrations to Standards	21
6.4	Core Sample COPCs.....	21
6.4.1	Identification of Alluvial Core COPCs.....	21
6.5	Summary	22
7.0	PHYSICAL SYSTEM CONCEPTUAL MODEL	22
7.1	COPCs in Sediments.....	23
7.1.1	Inorganic Chemicals in Sediments.....	23
7.1.2	Organic Chemicals in Sediments	29
7.1.3	Radionuclides in Sediments.....	33
7.1.4	Summary of Sources and Distribution of Key Sediment COPCs.....	34
7.1.5	Temporal Changes in Contaminant Concentration	39
7.2	Conceptual Model for Hydrology and contaminant transport in water	40
7.2.1	Hydrologic Conceptual Model	40
7.2.2	COPCs in Water.....	44
8.0	RISK ASSESSMENTS.....	55
8.1	Baseline Ecological Risk Assessment.....	55
8.1.1	Problem Formulation	56
8.1.2	Study Design, Field Verification, and Site Investigation.....	61
8.1.3	Characterization of Exposure and Effects.....	63
8.1.4	Risk Characterization	72
8.1.5	Summary	77
8.2	Human Health Risk Assessment.....	77
8.2.1	Problem Formulation	77
8.2.2	Data Collection and Evaluation	78
8.2.3	Exposure Assessment.....	79

8.2.4	Toxicity Assessment.....	81
8.2.5	Risk Characterization	82
8.2.6	Uncertainty Analysis.....	84
8.2.7	Summary of the Human Health Risk Assessment.....	86
9.0	CONCLUSIONS AND RECOMMENDATIONS	86
10.0	ACKNOWLEDGMENTS	88
11.0	REFERENCES.....	89

Figures

Figure 1.1-1	Pajarito watershed, showing major subbasins.....	101
Figure 1.1-2	Pajarito watershed, showing TA boundaries	102
Figure 3.1-1	Sediment investigation reaches in the Pajarito watershed	103
Figure 3.2-1	Water-sampling locations in the Pajarito watershed.....	104
Figure 7.1-1	Estimated average concentrations of select inorganic chemicals in fine facies sediment in the Pajarito watershed.....	105
Figure 7.1-2	Estimated average concentrations of select PCBs in fine facies sediment in the Pajarito watershed	112
Figure 7.1-3	Estimated average concentrations of select PAHs in fine facies sediment in the Pajarito watershed.	113
Figure 7.1-4	Estimated average concentrations of select SVOCs in fine facies sediment in the Pajarito watershed.	116
Figure 7.1-5	Estimated average concentrations of the explosive compound TATB in fine facies sediment in the Pajarito watershed.....	117
Figure 7.1-6	Estimated average concentrations of select dioxins and furans in fine facies sediment in the Pajarito watershed	118
Figure 7.1-7	Estimated average concentrations of the pesticide DDT in fine facies sediment in the Pajarito watershed.	119
Figure 7.1-8	Estimated average concentrations of cesium-137 and plutonium-239,240 in fine facies sediment in the Pajarito watershed; value shown as the average background concentration in reaches where these radionuclides are not COPCs.	120
Figure 7.1-9	Estimated average concentrations of uranium-238 in fine facies sediment in the Pajarito watershed; value shown as the average background concentration in reaches where uranium-238 is not a COPC.	121
Figure 7.1-10	Spatial variations in silver concentration between TA-08 (reach AW-1) and the Rio Grande.....	121
Figure 7.1-11	Spatial variations in cadmium concentration between TA-09 (reach AEN-1) and the Rio Grande; upper plot shows maximum concentrations and averages in fine and coarse facies sediment in each reach; lower plot compares maximum in pre-fire and post-fire sediment.....	122
Figure 7.1-12	Spatial variations in chromium concentration between TA-09 (reach AEN-1) and the Rio Grande; upper plot shows maximum concentrations and averages in fine and coarse facies sediment in each reach; lower plot compares maximum in pre-fire and post-fire sediment.....	123

Figure 7.1-13	Spatial variations in copper concentration between TA-09 (reach AEN-1) and the Rio Grande; upper plot shows maximum concentrations and averages in fine and coarse facies sediment in each reach; lower plot compares maximum in pre-fire and post-fire sediment.....	124
Figure 7.1-14	Spatial variations Aroclor-1260 concentration between TA-03 (reach TWN-1E) and the Rio Grande; upper plot shows maximum concentrations and averages in fine and coarse facies sediment in each reach; lower plot compares maximum in pre-fire and post-fire sediment.....	125
Figure 7.1-15	Spatial variations in total uranium and uranium-238 concentration between TA-15 firing sites (reaches THM-1 and THS-1W) and the Rio Grande	126
Figure 7.1-16	Plot of uranium-238 vs. uranium-235 concentrations in Threemile Canyon sediment samples; the red line indicates values expected in natural uranium, and values plotting below the line indicate depleted uranium.....	127
Figure 7.1-17	Spatial variations in benzo(a)pyrene concentration between TA-03 (reach TWN-1E) and TA-08 (reach AW-1) and the Rio Grande	128
Figure 7.1-18	Temporal variations in the average concentrations of cadmium, chromium, and copper in fine facies sediment in reach PA-2W.	129
Figure 7.1-19	Temporal variations in the average concentrations of Aroclor-1260 and benzo(a)pyrene in fine facies sediment in reaches TW-4W and TW-4E.....	130
Figure 7.2-1	Conceptual hydrogeologic cross section for Pajarito Canyon. Line of section follows the canyon stream channel.....	131
Figure 8.1-1	Biota investigation locations in the Pajarito watershed.....	132
Figure 8.1-2	Box plots showing percent fledged in the Pajarito watershed compared with reference for western bluebirds.....	133
Figure 8.1-3	Box plots showing percent female in the Pajarito watershed compared with reference for western bluebirds.....	133
Figure 8.1-4	Box plots showing egg length for the Pajarito watershed compared with reference for western bluebirds.....	134
Figure 8.1-5	Box plots showing egg weight for the Pajarito watershed compared with reference for western bluebirds.....	134
Figure 8.1-6	Box plots showing eggshell thickness for the Pajarito watershed compared with reference for western bluebirds	135
Figure 8.1-7	Survival of earthworms in toxicity test compared with reference.....	136
Figure 8.1-8	Weight change in earthworms during toxicity test compared with reference.....	136
Figure 8.1-9	Shoot weight of surviving organisms in toxicity test by reach.....	137
Figure 8.1-10	Root weight of surviving organisms in toxicity test by reach.....	137
Figure 8.1-11	Fraction of plants surviving at end of toxicity test by reach	138
Figure 8.1-12	Percent survival at conclusion of chironomid toxicity test.....	138
Figure 8.1-13	Box plot of mean dry larval weight (in mg) per replicate after chironomid toxicity test...	139
Figure 8.1-14	Box plot of mean chironomid survival compared with reference.	139
Figure 8.1-15	Box plot of mean chironomid growth relative to laboratory control compared with reference	140
Figure 8.1-16	Scatter plot of mean chironomid growth relative to laboratory control versus total silt. Linear regression: $y = 0.78 + 0.040 * X$; $r^2=0.46$; $n=27$	140

Tables

Table 3.1-1 Sediment Investigation Reaches in the Pajarito Watershed..... 141

Table 3.2-1 Pajarito Canyon Surface-Water and Groundwater-Sampling Locations and Rationale 143

Table 6.1-1 Surface Water and Groundwater Location Synonyms..... 146

Table 6.1-2 Crosswalk of Resamples and Original Samples for Sediment 148

Table 6.2-1 Pajarito Sediment Inorganic COPCs..... 149

Table 6.2-2 Pajarito Sediment Organic COPCs..... 151

Table 6.2-3 Pajarito Sediment Radionuclide COPCs..... 158

Table 6.3-1 Screening Table for Pajarito Watershed Metals in Alluvial Groundwater 159

Table 6.3-2 Screening Table for Pajarito Watershed Radionuclides in Alluvial Groundwater 161

Table 6.3-3 Screening Table for Pajarito Watershed Organics in Alluvial Groundwater 163

Table 6.3-4 Screening Table for Pajarito Watershed General Inorganics in Alluvial Groundwater 170

Table 6.3-5 Screening Table for Pajarito Watershed Metals in Intermediate Perched Groundwater 172

Table 6.3-6 Screening Table for Pajarito Watershed Radionuclides in Intermediate Perched Groundwater 174

Table 6.3-7 Screening Table for Pajarito Watershed Organics in Intermediate Perched Groundwater 176

Table 6.3-8 Screening Table for Pajarito Watershed General Inorganics in Intermediate Perched Groundwater 183

Table 6.3-9 Screening Table for Pajarito Watershed Metals in Regional Groundwater 185

Table 6.3-10 Screening Table for Pajarito Watershed Radionuclides in Regional Groundwater 187

Table 6.3-11 Screening Table for Pajarito Watershed Organics in Regional Groundwater 189

Table 6.3-12 Screening Table for Pajarito Watershed General Inorganics in Regional Groundwater 196

Table 6.3-13 Screening Table for Pajarito Watershed Metals in Springs Groundwater 199

Table 6.3-14 Screening Table for Pajarito Watershed Radionuclides in Springs Groundwater 201

Table 6.3-15 Screening Table for Pajarito Watershed Organics in Springs Groundwater 203

Table 6.3-16 Screening Table for Pajarito Watershed General Inorganics in Springs Groundwater 210

Table 6.3-17 Screening Table for Pajarito Watershed Metals in Surface Water (Base Flow and Springs) 212

Table 6.3-18 Screening Table for Pajarito Watershed Radionuclides in Surface Water (Base Flow and Springs) 216

Table 6.3-19 Screening Table for Pajarito Watershed Organics in Surface Water (Base Flow and Springs) 219

Table 6.3-20 Screening Table for Pajarito Watershed General Inorganics in Surface Water (Base Flow and Springs) 233

Table 6.4-1 Pajarito Alluvial Core Inorganic COPCs..... 237

Table 6.4-2	Pajarito Alluvial Core Organic COPCs.....	238
Table 6.4-3	Pajarito Alluvial Core Radionuclide COPCs	238
Table 6.5-1	Pajarito COPC Summary	238
Table 7.1-1	Inferred Primary Sources and Downcanyon Extent of Select COPCs in Sediment in the Pajarito Watershed.....	243
Table 8.1-1	COPECs by Media and Lines of Evidence Supporting Investigation of Each COPEC	245
Table 8.1-2	Field Studies in Pajarito Canyon Watershed as Implemented	247
Table 8.1-3	Samples Collected from Nest Boxes	249
Table 8.1-4	Summary of Sediment and Mammal Tissue PCB and Mercury Data.....	249
Table 8.1-5	Exposure Evaluation for the Southwestern Willow Flycatcher	250
Table 8.1-6	Exposure Evaluation for the Bat	252
Table 8.1-7	Comparisons of Insect Concentrations	253
Table 8.1-8	Comparisons of Concentration Ratios to Transfer Factors	253
Table 8.1-9	Exposure Evaluation for the Robin	254
Table 8.1-10	Exposure Evaluation for the Shrew.....	257
Table 8.1-11	Habitat Assessment Scores.....	259
Table 8.1-12	Macroinvertebrate Sample Abundance and Number of Taxa	259
Table 8.1-13	Lines of Evidence and Rationale for the Mexican Spotted Owl (AE1).....	260
Table 8.1-14	Lines of Evidence and Rationale for Avian and Mammalian Aerial Insectivores (AE6).....	260
Table 8.1-15	Lines of Evidence and Rationale for Avian Ground Invertevores (AE2).....	261
Table 8.1-16	Lines of Evidence and Rationale for Mammalian Invertevores and Omnivores (AE3)	262
Table 8.1-17	Lines of Evidence and Rationale for Detritivores (AE4).....	263
Table 8.1-18	Lines of Evidence and Rationale for Plants (AE5).....	263
Table 8.1-19	Lines of Evidence and Rationale for the Aquatic Community (AE7)	264
Table 8.2-1	Residential Risk Ratios Used to Identify Sediment COPCs, Noncarcinogens	265
Table 8.2-2	Residential Risk Ratios Used to Identify Sediment COPCs, Carcinogens	271
Table 8.2-3	Residential Risk Ratios Used to Identify Sediment COPCs, Radionuclide	277
Table 8.2-4	Residential Risk Ratios Used to Identify Surface Water COPCs, Noncarcinogens	279
Table 8.2-5	Residential Risk Ratios Used to Identify Surface Water COPCs, Carcinogens	285
Table 8.2-6	Residential Risk Ratios Used to Identify Surface Water COPCs, Radionuclides.....	288
Table 8.2-7	Reaches Evaluated for Water, Sediment, and Multimedia Exposure	290
Table 8.2-8	Site-Specific Exposure Scenarios and Complete Exposure Pathways	291
Table 8.2-9	Risk-Based Screening Levels for the Recreational Scenario	292
Table 8.2-10	Summary of Recreational Risk Assessment Results.....	294
Table 8.2-11	Risk Ratios Based on Exposure Point Concentrations for Sediment, Recreational Scenario	295
Table 8.2-12	Risk Ratios Based on Exposure Point Concentrations for Surface Water, Recreational Scenario.....	298

Table 8.2-13 Exposure Point Concentrations for Sediment COPCs, Recreational Scenario 303
Table 8.2-14 Exposure Point Concentrations for Surface Water COPCs, Recreational Scenario 306

Appendixes

Appendix A Acronyms and Abbreviations, Metric Conversion Table, and Data Qualifier Definitions
Appendix B Field Investigation Methods and Results
Appendix C Analytical Data
Appendix D Contaminant Trends
Appendix E Statistics and Risk Information
Appendix F Stormwater Analytical Results Greater Than Water Screening Action Levels, Summary for Potential Laboratory-Derived Pollutants
Appendix G Monitoring Well Reports (on CD included with this document)
Appendix H Core Moisture and Anion-Leachate and Tritium Data for Pajarito Canyon Deep Core Holes
Appendix I Analysis of Transient Water Levels Observed at Regional Aquifer Monitoring Wells near Pajarito Canyon
Appendix J Summary of the Spinner Test Conducted at PM-2
Appendix K Hydrogeological Information about Selected Springs in the Pajarito Canyon Watershed
Appendix L Analysis of Stream Flow and Alluvial Water Levels
Appendix M Evaluation of Existing Monitoring Well Locations for the Purpose of Detecting Potential Contaminants from the Pajarito Canyon Watershed
Appendix N Direct Current Resistivity Survey in Pajarito Canyon

Attachments

Attachment 1 Environmental Restoration Database and Water-Quality Database Analytical Data Packages (included on DVDs with this document)
Attachment 2 Environmental Restoration Database and Water-Quality Database Analytical Data; Hydrology, Geochemistry, and Geology Regional Well Core Leachate and Moisture Data; Sediment Particle-Size Data; Water-Level Data; Spinner Log Data; Nest Box Egg Measures; and Nest Box Success Measures (included on CD with this document)

Plates

- Plate 1 Pajarito Canyon Watershed
- Plate 2 Pajarito Canyon Geomorphology, Reaches PA-0, TW-1E, TW-1W, TW-2E, TWN-1E, TWN-1W, and TWSW-1W
- Plate 3 Pajarito Canyon Geomorphology, Reaches AEN-1, AES-1, AW-1, PA-1C, PA-1E, PA-1W, PAS-1E, PAS-2W, and TWSE-1W
- Plate 4 Pajarito Canyon Geomorphology, Reaches PA-2E, PA-2W, TH-1C, TH-1E, THW-1, TW-3E, TW-4E, TW-4W, TWSE-1E, and TWSW-1E
- Plate 5 Pajarito Canyon Geomorphology, Reaches PA-3E, TH-2E, TH-3, THM-1, THS-1E, and THS-1W
- Plate 6 Pajarito Canyon Geomorphology, Reaches PA-4, PA-4E, and PA-5W

1.0 INTRODUCTION

Los Alamos National Laboratory (LANL or the Laboratory) is a multidisciplinary research facility operated by the U.S. Department of Energy (DOE). The Laboratory is located in north-central New Mexico, approximately 90 km (60 mi) northeast of Albuquerque and 30 km (20 mi) northwest of Santa Fe. The Laboratory has an area of 103 km² (40 mi²), mostly on the Pajarito Plateau, which consists of a series of mesas separated by eastward-draining canyons. It also includes part of White Rock Canyon along the Rio Grande to the east. The Laboratory is currently investigating sites potentially contaminated by past operations to ensure that contaminants do not threaten human health or the environment. The sites under investigation are designated as solid waste management units (SWMUs) or areas of concern (AOCs). Contamination in canyon bottoms and in groundwater is being investigated on a watershed basis between the sources and the Rio Grande, the master drainage in the region, in addition to investigations at individual SWMUs and AOCs.

1.1 Purpose and Scope

This investigation report presents the results of studies conducted from 2000 to 2008 in Pajarito, Threemile, and Twomile Canyons and their tributaries. This area is collectively referred to in this report as the Pajarito watershed. Figure 1.1-1 shows the entire Pajarito watershed and the primary subwatersheds or basins, and Figure 1.1-2 shows more detail within the primary investigation area. The investigations reported herein address sediment, surface water, groundwater, and biota potentially impacted by SWMUs and AOCs located within the Pajarito watershed. These media are collectively referred to as canyons media in this report.

The investigations were conducted to fulfill the requirements of several documents. The "Work Plan for Pajarito Canyon" (hereafter called "the work plan") (see 1998, 059577, Appendixes B, C) describes work scope and regulatory requirements for characterizing the Pajarito watershed for the former Environmental Restoration (ER) Project. It contains a background review of SWMUs and AOCs in the watershed, the history of releases, and a review of contaminant data collected before the work plan was prepared. The New Mexico Environment Department (NMED) approved the work plan in 2005 following the Laboratory's response to a notice of deficiency (NOD) (LANL 2005, 091287; NMED 2005, 091288). The requirement to implement the work plan was also included by reference in Section IV.B.4 ("Pajarito Canyon Watershed") in the March 1, 2005, Compliance Order on Consent (the Consent Order).

The investigations conducted for the work plan also followed the technical strategy presented in the "Core Document for Canyons Investigations" (hereafter "the canyons core document") (LANL 1997, 055622). The canyons core document was prepared after a pilot study in Los Alamos and Pueblo Canyons was implemented in 1996, with the goal of standardizing the technical strategy for work in canyons. In 1998, NMED approved the core document following the Laboratory's response to a request for supplemental information (LANL 1998, 057666; NMED 1998, 058638).

Several additional documents have been prepared to supplement the work plan. The "Pajarito Canyon Biota Investigation Work Plan" (LANL 2006, 093553), approved by NMED in 2007 (096332), provides a detailed biota sampling and characterization plan for the Pajarito watershed. This plan satisfies the requirement in the work plan to prepare a biological sampling plan for the Pajarito watershed. The Laboratory proposed a sampling and analysis plan for Phase 2 sediment investigations in the Pajarito watershed in Section 5.0 of the Pajarito Canyon Phase 1 summary report (LANL 2006, 091812), which was modified at the request of NMED (Goering 2006, 093027). Similarly, the Laboratory proposed a sampling and analysis plan for Phase 3 sediment investigations in the Pajarito watershed in Section 7.0 of the Pajarito Canyon Phase 2 summary report (LANL 2007, 095408), which was approved by NMED in 2007 (096474). Results of investigations of intermediate and regional groundwater beneath the Pajarito

watershed described in the Laboratory's "Hydrogeologic Workplan" (LANL 1998, 059599) are also included in this report.

Data collected during the investigations included in this report are used to (1) define the nature and extent of contamination within the canyon bottoms and in groundwater beneath the Pajarito watershed; (2) update the conceptual model for contaminant distribution and transport within the canyons and underlying groundwater; (3) assess potential present-day human health and ecological risk from contaminants within the canyons; (4) determine and recommend potential remedial actions, if needed, that may be appropriate to achieve or maintain site conditions at an acceptable risk level; and (5) provide support for decisions at SWMUs and AOCs. The assessments in this report are conducted using data collected by the former ER Project since 2000 to evaluate current environmental conditions. Data from prior investigations and from environmental surveillance sampling are used to help identify temporal trends in contamination and therefore help evaluate how potential risk may change in the future relative to present-day conditions.

This report addresses characterization and risk assessment on the spatial scale of an entire canyon system, encompassing approximately 35 km (22 mi) of canyon bottom downstream of SWMUs and AOCs. The characterization and assessment approach used in this investigation provides an integrating perspective on historical and current contaminant releases to the canyon floor and subsequent contaminant redistribution resulting from various transport processes. This approach facilitates the development of conceptual models that describe expected spatial and temporal trends in contaminant concentrations, thus supporting recommendations for long-term monitoring. The results also support the Laboratory's watershed approach by providing information on the extent of contamination associated with SWMUs and AOCs and SWMU and AOC aggregates in the watershed and by helping identify and prioritize remedial activities within the watershed. Information on radioactive materials and radionuclides, including the results of sampling and analysis of radioactive constituents, is voluntarily provided to NMED in accordance with DOE policy.

1.2 Organization of Investigation Report

This investigation report has the following sections, following the outline used in the NMED-approved "Mortandad Canyon Investigation Report" (LANL 2006, 094161; NMED 2007, 095109). Section 1 is an introduction to the report and to the Pajarito watershed. Section 2 provides background information on the sources and history of contaminant releases, previous investigations of canyons media, and remediation activities that have occurred in the watershed. Section 3 describes the scope of activities in this investigation. Section 4 introduces the field investigations. Section 5 describes the regulatory context of this investigation. Section 6 presents screening-level assessments that identify chemicals of potential concern (COPCs) and that help focus subsequent sections on the subset of the most important COPCs for evaluating potential human health risk. Section 7 presents a physical system conceptual model, including discussions of the nature, sources, extent, fate, and transport of select COPCs that are most relevant for evaluating potential human health and ecological risk and contaminant transport. Section 8 presents baseline ecological and human health risk results and assessments. Section 9 presents conclusions and recommendations. Acknowledgements of those who contributed to this report are listed in Section 10. Section 11 presents references cited in this report.

This report has the following appendixes. Appendix A presents a list of acronyms and abbreviations, a table showing conversion of metric units to U.S. customary units, and data qualifier definitions. Appendix B presents field investigation methods and results. These analytical results are also presented in Appendix C. Appendix D presents supporting information on contaminant trends and inventory. Appendix E presents supporting information on statistics and risk. Appendix F presents stormwater analytical results and comparisons to water screening action levels (wSALs). Appendix G presents

monitoring well reports for the Pajarito watershed (on an accompanying CD). Appendix H presents vadose-zone profiles from the Pajarito watershed. Appendix I presents an analysis of transient water levels observed at regional aquifer monitoring wells near Pajarito Canyon. Appendix J presents a summary of a spinner log test conducted at water-supply well PM-2. Appendix K presents an analysis of hydrogeological and geochemical information related to the 4-series springs in White Rock Canyon. Appendix L presents an analysis of transient water levels observed at alluvial aquifer monitoring wells in Pajarito Canyon. Appendix M presents an evaluation of the existing monitoring well network in the Pajarito watershed. Appendix N presents results of the Geophex resistivity surveys in the Pajarito watershed. The Environmental Restoration Database and Water Quality Database are on a compact disk (CD) in Attachment 1. Analytical results from this investigation are on a CD in Attachment 2.

1.3 Watershed Description

The Pajarito watershed heads in the Sierra de los Valles (the eastern Jemez Mountains) at Pajarito Mountain, at an elevation of 3182 m (10,441 ft) above sea level (asl) and extends approximately 24 km (13 mi) to the Rio Grande at an elevation of approximately 1650 m (5410 ft) asl (Figure 1.1-2). The watershed has a drainage area of 33 km² (13 mi²), of which 57% is on Laboratory land, 27% is on U.S. Forest Service land in the Santa Fe National Forest, a small area (0.1%) is on Valles Caldera National Preserve land, and the remaining 16% is on private land or land owned by Los Alamos County. Approximately 58% of the length of Pajarito Canyon, or 13.6 km (8.5 mi), is on Laboratory land between New Mexico State Highway 501 (NM 501, or West Jemez Road) and NM 4. The three largest tributaries to Pajarito Canyon are Threemile Canyon, Twomile Canyon, and the south fork of Pajarito Canyon. Threemile Canyon heads in Technical Area 14 (TA-14) and has a length of approximately 6.0 km (3.7 mi) and a drainage area of 4.3 km² (1.7 mi²), entirely on Laboratory land. Twomile Canyon heads in the Sierra de los Valles and has a length of approximately 9.4 km (5.8 mi) and a drainage area of 8.1 km² (3.1 mi²), 70% on Laboratory land. The south fork of Pajarito Canyon also heads in the Sierra de los Valles and has a length of approximately 4.6 km (2.9 mi) and a drainage area of 2.7 km² (1.0 mi²), 37% on Laboratory land. Additional information about the physical characteristics of the watershed is provided in Appendix L.

Bedrock geologic units exposed within Pajarito Canyon and tributary canyons on Laboratory land consist largely of Quaternary ignimbrites of the Tshirege Member of the Bandelier Tuff, with some Pliocene basaltic rocks of the Cerros del Rio volcanic field occurring near NM 4. Basaltic rocks of the Cerros del Rio volcanic field and underlying geologic units are exposed farther downcanyon toward the Rio Grande, and Miocene and Pliocene dacitic rocks of the Tschicoma Formation occur in the Sierra de los Valles west of NM 501 (Griggs and Hem 1964, 092516; Smith et al. 1970, 009752; Dethier 1997, 049843; Gardner et al. 1999, 063492; Lewis et al. 2002, 073785). Geologic units within the watershed are discussed in more detail in Section 7 of this report.

A comprehensive overview of the biological setting of the Pajarito watershed is provided in the "Pajarito Canyon Biota Investigation Work Plan" (LANL 2006, 093553). Details about the hydrology are provided in Section 7 and Appendix B of this report.

1.4 Current Land Use

The portion of the Pajarito watershed downcanyon from SWMUs and AOCs is located on DOE land, private land in the White Rock townsite, and Los Alamos County land. Currently, active Laboratory operations occur in the canyon bottom in TA-18 at the confluence of Pajarito and Threemile Canyons. Elsewhere, Laboratory activities in canyon bottoms are restricted to environmental work, such as sediment and water sampling. Currently, there is no public access to the watershed on Laboratory land

downcanyon from SWMUs and AOCs, although parts of the canyons may be used by Laboratory personnel for recreational activities, such as hiking. The portion of the Pajarito watershed east of NM 4 includes residential areas in White Rock and Los Alamos County open space that is used for hiking, horseback riding, bike riding, and other recreational activities.

2.0 BACKGROUND

Contaminants consisting of inorganic chemicals, organic chemicals, and radionuclides have been released into the Pajarito watershed from a variety of sources, primarily Laboratory operations in several TAs, since the Laboratory was established in 1943. Much of the contamination related to Laboratory releases in this watershed is associated with effluent discharges, and releases of contaminants have decreased over time due to changes in Laboratory operations and decreased effluent volumes. Additional sources include dispersal of material from firing sites during open-air testing and runoff from material disposal areas (MDAs) and other SWMUs or AOCs. Regardless of the source(s), the contaminants have been dispersed downcanyon in sediment, surface water, and alluvial groundwater. Subsequently, some contaminants may have percolated into the subsurface, potentially affecting vadose-zone pore water and underlying intermediate perched water and regional groundwater. The following sections summarize the sources and history of contaminant releases as well as investigations that have addressed contaminant distribution and concentration in canyons media. Remediation activities implemented to reduce contamination in the canyon bottoms or in source areas are also discussed.

2.1 Sources and History of Contaminant Releases

2.1.1 TA-03

TA-03, the location of the main administration building and research laboratories at the Laboratory, borders the north side of the north fork of Twomile Canyon. It was the location of a firing site during the Manhattan Project, and operational facilities were shifted here from the Los Alamos townsite beginning in 1950. Runoff from large paved areas and buildings provides a major source of surface water for Twomile Canyon. SWMUs and AOCs located in the Pajarito watershed in TA-03 include storm drains, sumps, storage areas, outfalls, septic tanks, transformers containing polychlorinated biphenyls (PCBs), and stack emissions and are discussed in the work plan (LANL 1998, 059577, pp. 2-18-2-21). One site of concern at TA-03 is a former vacuum repair shop, SWMU 03-010(a), where mercury and other contamination occurred on a hillside above a tributary to Twomile Canyon (LANL 1995, 046195, pp. 3-59-3-60; LANL 1998, 059577). Elevated concentrations of copper and zinc have been measured in stormwater samples in another tributary to Twomile Canyon at TA-03 below large paved areas and the Laboratory's main machine shop (e.g., LANL 2007, 098644, p. 226).

2.1.2 TA-06, TA-22, TA-40, and former TA-07

TA-06, TA-22, TA-40, and former TA-07 are located on Twomile Mesa between Pajarito and Twomile Canyons. Operations began here in 1944 during the Manhattan Project in support of development of an implosion weapon, and development and testing of explosives continues to the present at TA-22 and TA-40. SWMUs and AOCs located in these TAs include firing sites, sumps, outfalls, storage areas, and surface and subsurface disposal areas, which are discussed in the work plan (LANL 1998, 059577, pp. 2-14-2-28).

2.1.3 TA-08, TA-09, TA-69, and former TA-23

TA-08 (Anchor West), TA-09 (Anchor East), TA-69, and former TA-23 are located in the western part of the Laboratory within the drainage basins of Pajarito and Twomile Canyons and the south fork of Pajarito

Canyon. These TAs contain some of the earliest Manhattan Project sites at the Laboratory, including the Gun Firing Site, which was established in 1943. Development and testing of explosives currently continue at TA-08 and TA-09. SWMUs and AOCs located in these TAs include firing sites, outfalls, septic tanks, sumps, storage areas, an incinerator ash pond, and surface and subsurface disposal areas, and are discussed in the work plan (LANL 1998, 059577, pp. 2-9-2-14). Sampling of sediment along hillside drainages below MDA M in TA-09, SWMU 09-013, indicated some transport of metals in surface runoff from this site (LANL 1995, 047257, pp. 3-27-3-28, 3-57-3-59; LANL 1998, 059577).

2.1.4 Former TA-12

Former TA-12 (L-Site) was located on Pajarito Mesa between Pajarito and Threemile Canyons and is within the current boundaries of TA-15 and TA-67. L-Site was constructed in 1944 for explosives testing and abandoned in 1953. SWMUs here include a firing site and associated support structures (LANL 1998, 059577, pp. 2-22-2-24).

2.1.5 TA-15

TA-15 (R-Site) is located on Threemile Mesa south of Threemile Canyon. It was first developed in 1944 and continues to be the site of explosives testing and related support structures. SWMUs and AOCs within the Pajarito watershed in TA-15 include firing sites, septic systems, outfalls, and disposal areas (LANL 1998, 059577, pp. 2-24-2-28). The E-F firing site [(SWMU 15-004(f))] is the largest at TA-15 and was active from 1947 to 1981. The R-44 firing site [(SWMU 15-008(b))] was also used for large diagnostic tests of weapons components and was active from 1951 to 1992. Beryllium, lead, mercury, uranium, and other metals were used in open-air explosive testing at these sites. Uranium isotopes and other contaminants have been detected in samples of stormwater and sediment in the Threemile Canyon watershed below TA-15 firing sites (e.g., LANL 2007, 098644, p. 226; LANL 2007, 095408).

2.1.6 TA-18

TA-18 (Pajarito Site) is located in the canyon bottom at the confluence of Pajarito and Threemile Canyons. TA-18 was first developed in 1943 to study properties of radioactive materials and then was used as a firing site. Beginning in 1946, it was the site of nuclear criticality experiments. SWMUs and AOCs at TA-18 include septic systems, outfalls, firing sites, underground storage tanks, and surface disposal areas (LANL 1998, 059577, pp. 2-28-2-33). Borehole samples and alluvial groundwater samples have indicated the presence of inorganic, organic, and radionuclide COPCS in the subsurface beneath the canyon bottom. Surface water and sediment samples collected from wetlands downcanyon from TA-18 also indicate the possible surface transport of contaminants from this site (LANL 1995, 055527; LANL 1996, 054919; LANL 1997, 057015; LANL 1998, 059577, pp. 3-27-3-30, 3-34-3-35, 3-60-3-62, 3-86-3-92).

Currently, TA-18 is undergoing decontamination and decommissioning (D&D) (Birdsell 2008, 102779). Operations at TA-18 were stopped in July 2004, and criticality experiments will resume at the Nevada Test Site (NTS). Since July 2004, the nuclear material has been repackaged and moved to NTS or to TA-55. Some material was also disposed of at TA-54, Area G. Equipment has also been removed from TA-18. In general, the machines were disassembled, cleaned, and packaged (in or around 2006) and will be moved to NTS. Some obsolete equipment was disposed of at Area G. Starting in fiscal year 2009, the buildings at TA-18 will undergo D&D. The plan is to return the site to natural conditions.

2.1.7 TA-36 and Former TA-27

Former TA-27 (Gamma Site) was located within the current boundaries of TA-36 in the bottom of Pajarito Canyon between TA-18 and NM 4. It was established in 1944 for weapons testing, which continued until 1947. TA-36 (Kappa Site) includes part of Pajarito and Threemile Canyons and the mesas to the south and was established in 1950 for explosives testing. SWMUs and AOCs within the Pajarito watershed in TA-36 and former TA-27 include firing sites, sumps, septic systems, and outfalls (LANL 1998, 059577, pp. 2-33-2-36).

2.1.8 TA-48

TA-48, the Radiochemistry Site, is located along the north side of Twomile Canyon south of Pajarito Road and is the location of radiochemistry and nuclear medicine research. The primary source of potential contamination in the Pajarito watershed from TA-48 is an air exhaust system from the radiochemistry building, which dates to 1957 (LANL 1998, 059577, pp. 2-21-2-22).

2.1.9 TA-54

TA-54 is located on Mesita del Buey on the north side of Pajarito Canyon and has been used for storage and disposal of waste since 1957. It includes three MDAs within the Pajarito watershed. MDA G has been the active radioactive low-level radioactive waste disposal area for the Laboratory since 1957. MDA H was used for the disposal of classified wastes in shafts from 1960 to 1986. MDA J has been used since 1961 for disposal of administratively controlled waste, for surface storage of asbestos, and for land-farming (aeration) of petroleum-contaminated soils (LANL 1998, 059577, pp. 2-36-2-39). Transport of low levels of some radionuclides and other contaminants in surface runoff has been documented in drainages along the south side of Mesita del Buey below MDA G, and tritium migration has been measured in the subsurface (e.g., LANL 1996, 054462; Jansen and Taylor 1997, 055873; LANL 1998, 059577, pp. 3-25-3-36, 3-30-31, 3-35-36, 3-57-3-58; LANL 2007, 098644, pp. 226-227).

2.1.10 TA-55

TA-55 is located along the north side of Twomile Canyon south of Pajarito Road and was established in 1973 for operation of the Plutonium Processing Facility. The only SWMU at TA-55 within the Pajarito watershed is an outfall that discharges stormwater (LANL 1998, 059577, pp. 2-21-2-22).

2.1.11 TA-59

TA-59 is located along the north rim of Twomile Canyon south of Pajarito Road and has included offices and light laboratories. SWMUs and AOCs located at TA-59 include a septic system, a container storage area, a sump, and an outfall and are discussed in the work plan (LANL 1998, 059577, p. 2-21).

2.1.12 TA-64

TA-64 was established in 1987 along the north rim of Twomile Canyon south of Pajarito Road and is the Laboratory's Central Guard Site. The only SWMU in TA-64 is a storage area (LANL 1998, 059577, p. 2-21).

2.1.13 TA-66

TA-66 was established in 1989 along the north rim of Twomile Canyon south of Pajarito Road when the Laboratory redefined technical area boundaries. It is the former site of the Laboratory's Russian Nonproliferation Program and currently houses the Center for Homeland Security. There is only one building at TA-66 and no SWMUs or AOCs (LANL 1990, 007514; LANL 2006, 094004).

2.1.14 Runoff from Developed Areas

Many of the Laboratory TAs within the Pajarito watershed are highly developed, including Laboratory facilities, storage locations, and parking lots. Runoff from developed areas transport various contaminants associated with urban areas into the canyons. Contaminants commonly found below developed areas include constituents in motor oil, gasoline, diesel, asphalt, road salt, PCBs, heavy metals, and pesticides. Polycyclic aromatic hydrocarbons (PAHs), suspected carcinogens that are frequently associated with vehicle usage and asphalt, are a common class of contaminants associated with developed areas (Edwards 1983, 082302; Lopes and Dionne 1998, 082309; Van Metre et al. 2000, 082262). Metals that have been identified as associated with runoff from roads include cadmium, chromium, copper, lead, nickel, and zinc (Walker et al. 1999, 082308; Breault and Granato 2000, 082310, p. 49). Consistent with studies in other regions, investigations in other canyons in and near the Laboratory have identified various inorganic and organic COPCs as being associated with runoff from developed areas (LANL 2004, 087390, pp. 7-14, 7-16).

2.1.15 Cerro Grande Fire

In May 2000, the Cerro Grande fire burned a large part of the Pajarito watershed west of NM 4. Approximately 21 km² (5066 acres) of the watershed was within the burn perimeter (BAER 2000, 072659), comprising 73% of the watershed above the highway. Most of this area, 71%, was classified as low-burn severity or not burned and the remainder as high- or moderate-burn severity. Various naturally occurring inorganic chemicals (e.g., barium, cobalt, and manganese) and anthropogenically created fallout radionuclides (e.g., cesium-137, plutonium-239,240, and strontium-90) were concentrated in Cerro Grande ash at levels exceeding that of background sediments before the fire, and the transport of ash has resulted in elevated levels of these analytes in post-fire sediment deposits in some canyons, including Pajarito Canyon (Katzman et al. 2001, 072660; Kraig et al. 2002, 085536; LANL 2004, 087390). Elevated levels of inorganic chemicals and radionuclides that can be attributed to the transport of ash have also been found in stormwater samples in some canyons (Gallaher and Koch 2004, 088747).

2.2 Contamination in Canyons Media

Contamination in sediment, surface water, and groundwater in the Pajarito watershed has been evaluated in several studies before this report, dating back to 1971 (Purtymun 1971, 004795). This previous work documented the presence of elevated levels of inorganic chemicals, organic chemicals, and radionuclides in canyon media and has evaluated the potential effects of contaminants on biota. Some key studies, summarized below, provide background and supplemental data for the investigations presented in this report. Relevant information from these studies is also included in subsequent sections of this report.

2.2.1 Environmental Surveillance Program

The Laboratory's Environmental Surveillance Program (ESP) has sampled and analyzed sediments, surface water, and groundwater in the Pajarito watershed since 1967. This work, reported in annual Environmental Surveillance reports (e.g., 2007, 098644), and in other reports (e.g., Purtymun 1971,

004795; Purtymun 1973, 004971; Purtymun 1975, 011787; Devaurs 1985, 007416; Devaurs and Purtymun 1985, 007415; Gallaher and Koch 2004, 088747) supports the evaluation of long-term trends in contamination in different media and an understanding of the role of stormwater transport. A summary of all results from active channel sediment sampling in the Pajarito watershed from 1974 to 1997 is presented in the work plan (LANL 1998, 059577, pp. 3-19-3-25).

2.2.2 Ecology Group

The Laboratory's Ecology Group has conducted studies on the potential uptake of contaminants by biota in Pajarito Canyon. These studies include addressing potential effects of contaminants on small mammals (Bennett et al. 2002, 073796), reptiles and amphibians (Nelson et al. 1998, 092224), and aquatic invertebrates (Cross 1995, 092221). Additional studies by the Ecology Group were conducted as part of this investigation and are summarized in Section 8.1.

2.2.3 Environmental Restoration Project

Since 2000, detailed studies of canyons media in the Pajarito watershed have been conducted by the former ER Project and successor organizations. Summaries of results of sediment investigations through 2007 have been presented previously (LANL 2006, 091812; LANL 2007, 095408). Supplemental data on contamination in canyons media are available through other ER Project reports (e.g., LANL 1995, 047257; LANL 1995, 055527; LANL 1996, 054462; LANL 1996, 054919; LANL 2003, 077965; LANL 2005, 090513; LANL 2005, 088716). The work presented in this investigation report builds on these previous studies.

2.2.4 NMED and EPA

NMED and the US Environmental Protection Agency (EPA) or their subcontractors have collected and analyzed samples from canyons media and conducted aquatic macroinvertebrate studies in the Pajarito watershed as part of oversight activities (e.g., Dale et al. 1996, 057014; Ford-Schmid 1996, 059111; NMED 1997, 057582; Yanicak 1998, 057583; EPA 2001, 070669). These data provide supplemental information about contamination in the watershed.

2.3 Remediation Activities

Several remediation activities in the Pajarito watershed have reduced the potential for transport of contaminants from SWMUs or AOCs into the canyon bottoms. The activities most relevant to this investigation are summarized below.

2.3.1 MDA M

In 1995 and 1996, an expedited cleanup was conducted at MDA M [(SWMU 09-013)], located on the mesa between Pajarito Canyon and the south fork of Pajarito Canyon, where sediment samples had indicated some surface transport of contaminants into the adjacent canyons. The cleanup included removal of approximately 4150 m³ (5460 yd³) of waste and the installation of runoff diversions, reducing the potential for transport of contaminants into Pajarito Canyon (LANL 1995, 047257, p. 2-13; LANL 1998, 059577).

2.3.2 TA-69 Incinerator Ash Pond

In 1996, a voluntary corrective action (VCA) was conducted at the site of an incinerator ash pond at TA-69 (SWMU 69-001), located on the south rim of Twomile Canyon. Before the VCA, the berm surrounding the pond had been breached, allowing transport of ash and other noncombustible material from the pond down the hillslope to the stream channel. The VCA included removal of approximately 200 m³ (265 yd³) of waste, the placement of log silt dams, and recontouring of the berms, reducing the potential for transport of contaminants into Twomile Canyon (LANL 1996, 054334; LANL 1998, 059577, pp. 2-13-2-14).

2.3.3 Erosion Control

Active erosion control measures have been taken at numerous SWMUs and AOCs in the Pajarito watershed, including run-on and runoff control and surface stabilization. These measures are referred to as “best management practices” and are discussed in the Laboratory’s annual “Storm Water Pollution Prevention Plan” (e.g., LANL 2007, 096981).

3.0 SCOPE OF ACTIVITIES

The scope of activities in this report includes investigations of sediment, surface water, groundwater, and biota in the Pajarito watershed, as presented in the work plan and subsequent documents (LANL 1998, 059577; LANL 2005, 091287; LANL 2006, 093553). These investigations are discussed below.

3.1 Sediment Investigations

The sediment investigations presented in this report focused on characterizing the nature, extent, and concentrations of contaminants in post-1942 sediment deposits in a series of reaches in the Pajarito watershed. Data from these reaches are used to evaluate potential human health and ecological risks and to identify spatial trends in contamination at a watershed scale, including variations in contaminant concentration and inventory at increasing distances from source areas. The investigation methods are discussed in Section 4 and Appendix B, Section B-1.0, of this report, in the work plan (LANL 1998, 059577; LANL 2005, 091287), and in the canyons core document (LANL 1997, 055622; LANL 1998, 057666).

The scope of this investigation included characterization of the 14 reaches identified as priority reaches in the work plan (LANL 1998, 059577, p. 7-10), as well as work in 20 additional reaches. Most of these additional reaches were contingency reaches identified in the work plan (LANL 1998, 059577, p. 7-10), with sampling contingent on results of upcanyon or downcanyon sampling. Ten reaches were sampled in 2000 either to provide initial data on COPCs in sediment deposits present before the Cerro Grande fire, in case these deposits were eroded by post-fire floods, or to directly characterize post-fire sediment deposits. Sampling in two reaches, PA-2W and TW-4E, targeted sediment deposited by floods on August 24, 2005, and August 25, 2006, in the impoundment upcanyon from the Pajarito Canyon flood retention structure (FRS). Table 3.1-1 lists the sediment investigation reaches and the years in which samples were collected in each reach. Table 3.1-1 also provides abbreviations for reach names included in this report and the approximate length and distance of each reach from the Rio Grande, as well as additional information on the reaches. Locations of reaches are shown in Figure 3.1-1 and on Plate 1.

Sediment characterization was also conducted to support the biota investigations presented in the “Pajarito Canyon Biota Investigation Work Plan” (LANL 2006, 093553), as modified in the “Summary of Pajarito Canyon Phase 2 Sediment Investigations” (LANL 2007, 095408, pp. 4-6). Sampling and analysis were conducted to provide additional data to support the assessment of potential ecological effects from

contaminants found in sediment. This characterization included resampling previously sampled sediment layers in some reaches and collecting samples at new locations in other reaches. Details of the methodology are presented in Section B-3.0 of Appendix B.

3.2 Surface-Water and Groundwater Investigations

The water investigations presented in this report focus on watershed-scale characterization of surface-water base-flow, springs, alluvial groundwater, intermediate perched groundwater, and regional groundwater within and beneath the Pajarito watershed. Data from these components of the hydrogeologic system are used to evaluate potential human health and ecological risk as well as to identify spatial trends in contamination at a watershed scale, including variations in contaminant concentration at increasing distances from the source areas and as a function of seasonal and annual hydrologic variations. The data are also used to identify temporal trends in contamination. This work involved sampling persistent surface water and springs, drilling and installing monitoring wells, sampling new and preexisting groundwater wells, and measuring water-level variations in all groundwater sources. Persistent surface water generally refers to spring-supported surface-water flow, snowmelt runoff, and other surface water not related to short-duration stormwater runoff, (Section 7.2 further discusses the hydrology of the watershed.) Figure 3.2-1 shows the locations of surface-water and groundwater sites sampled as part of this investigation. The investigation methods are discussed in Section 4.2 and Appendix B of this report. The scope of the investigation is described in the work plan (LANL 1998, 059577) and in NMED's approval with modifications (2005, 091288). The investigation activities described above are discussed in the following sections.

3.2.1 Monitoring Well Installations

Seven new alluvial monitoring wells were installed in Pajarito Canyon in 2008. Shallow canyon-floor bedrock prevented installation of six additional planned alluvial wells, as described in Section 3.4 below. Well completion diagrams and geologic logs for the new wells and boreholes are provided on CD in Appendix G. Other alluvial monitoring wells installed in Pajarito Canyon from 1985 to 1994 for surveillance monitoring were used to supplement water-level and water-quality data used in this investigation. Well completion diagrams and geologic logs for these earlier wells are compiled in Purtymun (1995, 045344) and from the Laboratory (1995, 055527). Figure 3.2-1 and Plate 1 show the locations of the alluvial monitoring wells in the Pajarito watershed.

Well R-23i, a perched intermediate groundwater monitoring well, is located in lower Pajarito Canyon, south of Pajarito Road (Kleinfelder 2006, 092495) (Figure 3.2-1 and Plate 1). The well was installed to sample perched intermediate groundwater encountered during the drilling of regional well R-23 (LANL 2003, 079601). Well R-23 was drilled in 2002 as part of the "Hydrogeologic Workplan" (LANL 1998, 059599) to provide hydrogeologic data and monitor the regional aquifer near MDAs at TA-54. Well R-23i is located approximately 25 ft southwest of well R-23. Well R-23i was drilled in October 2005 to a total depth (TD) of 695 ft below ground surface (bgs). Perched intermediate groundwater was encountered within the Cerros del Rio basalt, and a 4.5-in. diameter well was installed with two screened intervals: one between 470.2 and 480.1 ft bgs and the other between 524 and 547 ft bgs. Additionally, a 2-in. diameter well was installed in the well R-23i annular space with a screened interval between 400.3 and 420 ft bgs.

Seven regional groundwater characterization and monitoring wells were installed in Pajarito Canyon, fulfilling the requirements of the work plan (LANL 1998, 059577) for six regional wells. Well completion diagrams and geologic logs for these wells are provided in the following reports: "Final Completion Report, Characterization Well R-17" (Kleinfelder 2006, 092493), "Final Completion Report, Characterization Well R-18" (Kleinfelder 2005, 092415), "Characterization Well R-19 Completion Report"

(Broxton et al. 2001, 071254), "Characterization Well R-20 Completion Report" (LANL 2003, 079600), "Characterization Well R-22 Completion Report" (Ball et al. 2002, 071471), "Characterization Well R-23 Completion Report" (LANL 2003, 079601), and "Characterization Well R-32 Completion Report" (LANL 2003, 079602).

Several regional wells in the Pajarito watershed have screens affected to different degrees by residual drilling fluids, which produce unreliable analytical results for many constituents. Individual locations and screens are discussed in the "Well Screen Analysis Report, Revision 2" (LANL 2007, 096330). The interim monitoring plan calls for the collection of groundwater from these screens and analysis of specific constituents that are not affected by residual drilling fluids in order to assess temporal trends in the geochemical performance of each potentially affected well screen interval.

A monitoring well network evaluation (LANL 2007, 098172) was conducted for TA-54 pursuant to a requirement set forth in NMED's letter on "Well Evaluations for Intermediate and Regional Wells," dated April 5, 2007 (2007, 095999). In addition, this evaluation was directed by requirements set forth by NMED's "Approval with Direction, Technical Area 54 Well Evaluation and Network Recommendations" (2007, 098283). The TA-54 groundwater-monitoring network evaluation was conducted to support ongoing investigations and pending corrective measures implemented under the Consent Order and to support ongoing operations at TA-54 under Resource Conservation and Recovery Act (RCRA) interim status. The draft RCRA Part B operating permit is pending, and the groundwater-monitoring well network will be a key aspect of the Laboratory's demonstration of compliance with the anticipated permit requirements. The TA-54 well network evaluation (LANL 2007, 098172) recommended that well rehabilitation activities be conducted at regional wells R-20, R-22, and R-32. Section 5 of the network evaluation report includes a detailed description of well rehabilitation recommendations.

Completed well rehabilitation activities at regional wells R-20 and R-32 are described in the report "Final Rev. 1, Rehabilitation Report for Regional Wells R-20 and R-16" (Kleinfelder 2007, 095030.2) and the "R-32 Rehabilitation and Conversion Summary Report, Revision 1" (LANL 2007, 100572). In addition, the network evaluation report recommended that additional regional and perched intermediate wells be installed in the vicinity of TA-54 to improve the efficiency of the monitoring well network. Two of the recommended regional wells (R-39 and R-40) and one perched intermediate well (PCI-1) are located in Pajarito Canyon (Plate 1); these wells are currently being installed. Installation of an additional regional well (R-41) and a perched intermediate well (PCI-2) in the Pajarito watershed near TA-54 are contingent on the results of ongoing drilling activities (LANL 2007, 098172; NMED 2007, 098283). Rehabilitation of well R-22 is also planned, and per NMED direction, the rehabilitation will be delayed until the latter part of 2009 when groundwater data for new wells R-39 and R-41 are available to help guide the rehabilitation approach (LANL 2008, 102998).

3.2.2 Surface Water, Springs, and Groundwater Sampling

Sampling activities included monitoring of 6 surface-water base-flow locations, 10 springs, 8 existing and 10 new alluvial wells, 5 intermediate wells, and 7 regional aquifer wells. Historical monitoring data from the Laboratory's ESP were used to supplement this investigation. Currently, locations and analyte suites for groundwater samples in the watershed are specified in the annual "Interim Facility-Wide Groundwater Monitoring Plan" (IFGMP) (LANL 2008, 101897), in accordance with requirements in the Consent Order. The list of surface-water sites and groundwater-monitoring wells used to prepare this investigation report are presented in Table 3.2-1. Additional surface-water sampling locations are listed in Table 3.2.2. These include stormwater sampling sites (see Appendix F) required under the Federal Facilities Compliance Agreement–Administrative Order (FFCA-AO) and base-flow sites that are no longer sampled as part of the IFGMP. Figure 3.2-1 shows the locations of the sampling sites listed in Table 3.2-1. Plate 1 shows the

same locations as well as additional monitoring wells, surface-water sampling locations, and production wells in the Pajarito watershed.

3.2.3 Water-Level Measurements

Both manual and automated water-level data have been collected from alluvial monitoring wells, piezometers, intermediate perched monitoring wells, and regional monitoring wells in the Pajarito watershed. A summary of water-level measurements for wells at the Laboratory, including those in the Pajarito watershed, is given in the annual report, "Groundwater Level Status Report for Fiscal Year 2007, Los Alamos National Laboratory" (Allen and Koch 2008, 101613). Details of the field methodology and results are presented in Section B-2.2 of Appendix B.

3.2.4 Surface Geophysics

A surface-based direct-current resistivity survey was conducted in Pajarito Canyon in 2005. The objective of the resistivity survey was to identify regions of higher conductivity beneath the canyon floor, which may be related to perched alluvial groundwater and to zones of infiltration in subcropping bedrock units. The survey was optimized to characterize variations in electrical conductivity in the upper 250 ft of the vadose zone. Details of the methodology and the results for the resistivity surveys are provided in the report, "DC Resistivity Profiling in DP, Los Alamos, Pajarito, Pueblo and Sandia Canyons, Los Alamos National Laboratory, Los Alamos, NM" (Geophex 2006, 094047). Locations of the resistivity survey lines and discussion of results are provided in Appendix N.

3.2.5 Characterization Core Holes

Characterization core holes were drilled as part of the installation of regional wells R-17, R-20, and R-32. Table 3.2-1 describes the core holes and provides information about their locations, purpose, and depths. Descriptions of coring activities and geologic logs are provided in the well completion reports for the regional wells (LANL 2003, 079602; LANL 2003, 079600; Kleinfelder 2006, 092493). Additional cores were collected during installation of alluvial monitoring wells, described in Section 3.2.1 above.

3.3 Biological Investigations

The biological investigations presented in this report focused on characterizing the potential for adverse effects of contaminants in post-1942 sediment deposits and surface water on terrestrial and aquatic ecological receptors. These investigations fulfill the general objectives identified in the work plan (LANL 1998, 059577; LANL 2005, 091287) and in the canyons core document (LANL 1997, 055622; LANL 1998, 057666). These investigations build upon the results obtained from sediment and surface-water characterization, and the basis for the investigation approach is documented in the "Pajarito Canyon Biota Investigation Work Plan" (LANL 2006, 093553). The investigation methods are discussed in Section 4.3 and Section B-3.0 in Appendix B of this report.

3.4 Deviations from Planned Activities

Attempts were made to install 13 alluvial monitoring wells in the Pajarito watershed in 2008, resulting in 7 new completed wells and six abandoned boreholes where shallow canyon-floor bedrock or alluvial cobbles and boulders prevented well installation. Multiple attempts were made to install wells PCAO-B, PCAO-1, PCAO-2, PCAO-3, PCAO-4, and 3MAO-2 in the areas of shallow bedrock but none were successful. An additional alluvial well (PCOA-7B2) was installed at the PCOA-7B location so that

groundwater could be monitored in saturated zones found in both shallow and deep alluvium settings; this additional alluvial well was not required by the work plan (LANL 1998, 059577).

An NOD for the work plan (NMED 2005, 089315) required installation of two sets of alluvial piezometers. The purpose of the piezometers was to identify whether infiltration beneath the canyon floor in the vicinity of TA-54 recharges vadose-zone groundwater, thus providing a potential contaminant pathway to perched intermediate groundwater and to regional groundwater. Because the Laboratory proposed the installation of two perched intermediate wells in the vicinity of TA-54 as part of monitoring well network evaluation recommendations (LANL 2007, 098172), NMED agreed that detection of infiltration beneath Pajarito Canyon in the vicinity of TA-54 is better addressed by installation of the perched intermediate wells, and the requirement for two sets of piezometers was withdrawn (LANL 2008, 102998).

The work plan calls for two characterization sampling rounds of the alluvial wells. The results from only one round of sampling from the seven newly installed alluvial wells are available for this report. The new alluvial wells will be sampled on a quarterly basis to provide sufficient data to support an evaluation of future monitoring needs.

The biota investigation was completed as planned with one exception. It was planned to use yarrow (*Achillea millefolium*) seeds in the seedling germination test, based on American Society for Testing and Materials (ASTM) Method E1963-98. However, because of a change in vendor, it was not possible to obtain yarrow seeds in sufficient quantity for the tests. Instead, a standard test species, ryegrass (*Lolium perenne*), was substituted. This change in species had no impact meeting the investigation objective, which was to determine phytotoxicity for the sediment samples.

4.0 FIELD INVESTIGATIONS

Field investigations in the Pajarito watershed included investigations of sediment, surface water, groundwater, and biota. The approaches and methods of these investigations are briefly discussed in the following sections. A more detailed discussion of the methods and of the field investigations results is presented in Appendix B.

4.1 Sediment

Sediment investigations in the Pajarito watershed included detailed geomorphic characterization and sediment sampling in a series of discrete reaches, following the general process described in the NMED-approved work plan and canyons core document (LANL 1997, 055622; LANL 1998, 059577; LANL 1998, 057666; LANL 2005, 091287). The geomorphic characterization in most reaches included preparing a detailed geomorphic map delineating the horizontal extent of geomorphic units with varying physical characteristics, contaminant concentrations, and/or age. The geomorphic characterization also included measuring the thicknesses of potentially contaminated post-1942 sediment deposits to estimate the volume of contaminated sediment and the contaminant inventory in each reach. Several methods were used to identify the bottom of post-1942 sediment deposits, including determining the depth of buried trees and associated buried soils and noting the presence or absence of materials imported to the watershed after 1942 (e.g., quartzite gravel and plastic).

Field data on the volume of sediment in the different geomorphic units in a reach were used to help allocate samples for analysis at off-site laboratories. In some reaches, samples were collected in multiple phases, and analytical results from initial sampling phases were used to help guide subsequent sampling. Section B-1.0 of Appendix B includes more detailed discussion of the investigation methods. All analytical results of the sediment sampling incorporated in this investigation report are presented in Attachment 2 on a CD.

Plates 2 to 6 present geomorphic maps for reaches in the Pajarito watershed and sample locations and stratigraphic description locations within these reaches. The horizontal extent of contaminated or potentially contaminated sediment deposits in each reach is delineated by the extent of the channel (“c”) and floodplain (“f”) units in these maps. Section B-1.0 of Appendix B includes field investigation results, including sediment thickness measurements.

4.2 Surface Water and Groundwater

The surface-water and groundwater field investigations in the Pajarito Canyon watershed are designed to define the nature and extent of contamination, to identify the physical and chemical processes controlling contaminant distributions, and to identify the transport pathways, which could result in potential human health and ecological exposure and risk. This work includes sampling persistent surface water and springs, drilling and installing monitoring wells, sampling new and preexisting groundwater wells, and measuring water-level variations in all groundwater sources. In addition, core was collected to characterize the distribution of contaminants and moisture in rocks of the upper vadose zone. The investigation methods are discussed in Appendix B. The scope of the investigation is described in the “Work Plan for Pajarito Canyon” (LANL 1998, 059577) and the “Approval with Modifications, Pajarito Canyon Work Plan” (NMED 2005, 091288).

4.2.1 Monitoring Well Installations

Seven alluvial wells, one intermediate well, and seven regional wells were installed to fulfill the requirements of the “Work Plan for Pajarito Canyon” (LANL 1998, 059577) and the “Approval with Modifications, Pajarito Canyon Work Plan” (NMED 2005, 091288). Detailed well completion reports describe the investigation methods, well completion diagrams, geologic logs, and borehole geophysical logs for these wells. These well completion reports are described in Section 3.2.1. Table 3.2-1 provides information about the location, purpose, and depth of the wells.

4.2.2 Surface-Water and Groundwater Sampling

As described in Section 3.2, sampling of persistent surface water, springs, alluvial groundwater, perched intermediate groundwater, and regional groundwater was coordinated to provide a snapshot in time to evaluate the relationship between constituents in surface water and various groundwater bodies. Samples were collected at designated locations described in the “Work Plan for Pajarito Canyon” (LANL 1998, 059577) and the “Approval with Modifications, Pajarito Canyon Work Plan” (NMED 2005, 091288). Sampling locations are reviewed annually and modified as appropriate by the annual IFGWP in accordance with requirements of the Consent Order.

Procedures for sample collection are described in Appendix B. The analytical results of the sampling are discussed in Section 7.2, and the data are provided in Attachment 2 on a CD. Water-quality field parameters, including pH, specific conductance, temperature, and turbidity, were measured for each surface-water or groundwater sample collected. Measurements of field parameters were taken as part of the groundwater sampling to evaluate the effectiveness of purging of the well. Field parameters data were also collected for surface-water and groundwater for evaluating factors controlling contaminant variability.

4.2.3 Water-Level Measurements

Historical and new water-level data were compiled for alluvial, intermediate, and regional wells. These data, which included both manual and automated measurements, allow interconnections between groundwater bodies to be assessed by comparing water-level responses with storm events and seasonal

variations in precipitation. Water-level data were also collected to determine hydraulic gradients within groundwater bodies and to assess hydraulic conductivity. Details of the field methodology and results are presented in Appendix B.

4.2.4 Surface Geophysics

A surface-based direct-current resistivity survey was conducted in Pajarito Canyon in 2005. Details of the methodology and results for the resistivity surveys are provided in the report, "DC Resistivity Profiling in DP, Los Alamos, Pajarito, Pueblo and Sandia Canyons, Los Alamos National Laboratory, Los Alamos, NM" (Geophex 2006, 094047). Locations of the resistivity survey lines and discussion of results are provided in Appendix N.

4.2.5 Characterization Core Holes

Characterization core holes were drilled as part of the installation of regional wells R-17, R-20, and R-32. Table 3.2-1 describes the core holes and provides information about their locations, purpose, and depths. Additional cores were collected during installation of alluvial monitoring wells, as described in Section 3.2.1. Cores were collected from all major stratigraphic units to determine contaminant distributions in the upper vadose zone. Samples were containerized to prevent moisture loss and were analyzed for moisture content, metals, anions, stable isotopes, and radionuclides. Where feasible, borehole gamma and induction logs were collected in uncased portions of the boreholes. In general, the core holes were plugged and abandoned with bentonite after reaching TD.

Analytical data for cores are presented in Appendix H, and Section 7.2 discusses pore water extracted from cores. Appendix H also discusses moisture content of core samples.

4.3 Biota

Biological data were collected to evaluate the potential for adverse ecological effects from contaminants in sediment and surface water. Biota investigations in the Pajarito watershed included a range of activities, as presented in the NMED-approved "Pajarito Canyon Biota Investigation Work Plan" (LANL 2006, 093553). Field investigations included studies of bird nest boxes and aquatic macroinvertebrates, collection of sediment samples for earthworm toxicity tests, seedling germination tests, and aquatic toxicity tests. The nest box study included adding nest boxes to the existing network, collecting data on occupancy, and collecting samples of eggs for laboratory analyses. These activities are discussed in more detail in Section 8.1 and Section B-3.0 of Appendix B.

5.0 REGULATORY CRITERIA

This section provides information on the regulatory context, human health screening levels, ecological screening values, applicable water-quality standards, and screening levels.

5.1 Regulatory Context

Regulatory requirements governing the Laboratory's canyons investigations are discussed in Section 1.4 of the approved canyons core document (LANL 1997, 055622; LANL 1998, 057666; NMED 1998, 058638; LANL 2007, 096665). In particular, these investigations address requirements of the Laboratory's Hazardous Waste Facility Permit (Module VIII) under RCRA, including "the existence of contamination and the potential for movement or transport to or within Canyon watershed" (EPA 1990, 001585; EPA 1994, 044146). RCRA and the New Mexico Hazardous Waste Act (NMHWA) regulate releases of

hazardous wastes and hazardous waste constituents. DOE Order 5400.1, "General Environmental Protection Program," establishes requirements for managing residual radioactivity at DOE facilities.

As a result of the operational history of sites in the Pajarito watershed, this investigation addresses both radioactive and hazardous components. NMED has authority under the NMHWA over the cleanup of hazardous wastes and hazardous constituents, while DOE has authority over the cleanup of radioactive contamination. Radionuclides are regulated under DOE Order 5400.5, "Radiation Protection of the Public and the Environment," and DOE Order 435.1, "Radioactive Waste Management."

The regulatory requirements for conducting investigations in the Pajarito watershed are incorporated into Module VIII through work plans approved by NMED. The approved work plans include the "Work Plan for Pajarito Canyon" (LANL 1998, 059577), the Laboratory's "Hydrogeologic Workplan" (LANL 1998, 059599), the "Pajarito Canyon Biota Investigation Work Plan" (LANL 2006, 093553), the sampling and analysis plan for Phase 2 sediment investigations (LANL 2006, 091812), and the sampling and analysis plan for Phase 3 sediment investigations (LANL 2007, 095408). Corrective actions at the Laboratory are subject to the Consent Order, which contains general requirements and those specific to the Pajarito watershed (Section IV.B.4, "Pajarito Canyon Watershed"). The Consent Order was issued pursuant to NMHWA, New Mexico Statutes Annotated (NMSA) 1978 § 74-4-10 and the New Mexico Solid Waste Act, NMSA 1978, § 74-9-36(D). The requirements of the Consent Order now supersede those of Module VIII.

Surface-water discharges are subject to a permit under Section 402 of the federal Clean Water Act (CWA), including stormwater discharges, are not regulated under the Consent Order. Stormwater discharges from certain SWMUs and AOCs are regulated under an FFCA between EPA Region 6 and DOE, pursuant to the CWA, 33 U.S.C. Sections 1251–1387; and AO Docket No. CWA-06-2005-1734, issued on March 17, 2005, to the University of California (UC) as the Laboratory's Management and Operations Contractor for DOE. On June 1, 2006, Los Alamos National Security, LLC (LANS) became the Management and Operations Contractor of the Laboratory for DOE and the successor to UC. On November 16, 2006, EPA issued an amended AO reflecting the operator change and substituting LANS for UC.

The FFCA establishes a compliance program under the CWA for the regulation of stormwater discharges from specifically identified SWMUs and AOCs (collectively referred to as sites) until such time as these sources are regulated by an individual stormwater permit issued by EPA pursuant to the National Pollutant Discharge Elimination System (NPDES) permit program. The Laboratory's individual stormwater permit is expected to be issued during 2008 and will cover stormwater runoff from sites with significant industrial activity [see 40 Code of Federal Regulations 122.26(b)(14)].

Currently, the discharge of stormwater from industrial activities at the Laboratory is regulated by the NPDES Storm Water Multi-Sector General Permit (MSGP) Nos. NMR05A734 and NMR05A735, which became effective on December 23, 2000, pursuant to 65 Federal Register (FR) 64746. On December 1, 2005, EPA issued a proposed rule in the FR (70 FR 72116) that a new MSGP, which was to replace the existing permit that expired on October 30, 2005, was available and open for public comment. Until the new permit is issued, EPA administratively continued the 2000 MSGP. While the FFCA is in effect, the Laboratory must continue to comply with all requirements of the current MSGP. Pursuant to the MSGP, SWMUs fall under the category of Hazardous Waste Treatment, Storage, and Disposal Facilities (Sector K), which EPA Region 6 defines as a listed, regulated industrial activity. The assessments in this report are primarily risk based for all media and contaminants. Surface-water and groundwater standards are used to support the assessment of nature and extent of contamination in canyons media. Concentrations of chemicals and radionuclides are compared with various risk-based screening levels, which are described in Sections 5.2 and 5.3. Applicable water-quality standards are discussed in Section 5.4.

5.2 Human Health Screening Levels

In Section 6, soil screening levels (SSLs) for inorganic and organic chemicals and screening action levels (SALs) for radionuclides are media-specific concentrations derived for residential exposures. If environmental concentrations of contaminants are below SALs or SSLs, then the potential for adverse human health effects is highly unlikely. For sediment chemical COPCs with carcinogen or noncarcinogen endpoints, SSLs from NMED guidance (2006, 092513) were used if available. If values were not available from NMED, then residential screening values were obtained from EPA Region 6 (EPA 2007, 099314) or EPA Region 9 (<http://www.epa.gov/region09/waste/sfund/prg/files/04prgtable.pdf>). The SSLs for noncarcinogens are based on a hazard quotient (HQ) of 1.0. The SSLs for carcinogens are based on a cancer risk level of 10^{-5} (10E-5). For nonradionuclide COPCs without NMED SSLs, approved surrogate values were used (NMED 2003, 081172). SALs for radionuclides were obtained from Laboratory guidance (NMED 2003, 081172). The radionuclide SALs for sediment have a target dose limit of 15 millirem per year (mrem/yr), which is consistent with guidance from DOE (2000, 067489).

Human health screening levels for water are EPA Region 6 Human Health Medium Specific Screening Level (HHMSSL) tap water screening levels for carcinogens and noncarcinogens and DOE Derived Concentration Guidelines (DCG) for radionuclides. The screening levels for carcinogens and noncarcinogens in water are based on the same HQ and cancer risk levels as the SSLs. The screening values for radionuclides in groundwater were calculated based on a target dose limit of 4 mrem/yr, which is the radiation dose limit for a public drinking water supply in DOE Order 5400.5, "Radiation Protection of the Public and the Environment." The screening values for radionuclides in surface water were calculated based on a target dose limit of 100 mrem/yr, which is the radiation dose limit for the general public from all sources in DOE Order 5400.5, "Radiation Protection of the Public and the Environment."

Comparisons of sediment and water data to residential screening levels are provided in Section 6. Additional information regarding the potential for human health risks from affected media in the Pajarito watershed is provided in Section 8.1.

5.3 Ecological Screening Levels

Ecological screening levels (ESLs) are used to determine chemicals of potential ecological concern (COPECs) for water and sediment. The document, "Screening Level Ecological Risk Assessment Methods, Revision 2" (LANL 2004, 087630), contains information about how ESLs are derived. ESLs are developed for a suite of receptors designed to represent individual feeding guilds. Receptors such as robins and kestrels are modeled with multiple diets to represent multiple feeding guilds. The representative concentration of each COPC was compared with ESLs from the Ecorisk Database Version 2.2 (LANL 2005, 090032).

Additional information regarding the potential for ecological risks from affected media in the Pajarito watershed is provided in Section 8.1.

5.4 Water Quality Standards and Screening Levels

COPCs are identified by comparing concentrations in water with applicable water quality standards and screening values. The NMWQCC establishes surface-water standards in the "State of New Mexico Standards for Interstate and Intrastate Surface Waters" (New Mexico Administrative Code [NMAC] 20.6.4). Certain watercourses may be "classified" and have segment-specific designated uses. A designated use may be an attainable or an existing use (e.g., livestock watering) for the surface water. Nonclassified surface waters are described as ephemeral, intermittent, or perennial, each of which also

has corresponding designated uses described in NMAC 20.6.4.97-99. The designated uses for surface water are associated with use-specific water-quality criteria, including numeric criteria.

All surface waters within the Laboratory boundary are classified with segment-specific designated uses. Four segments at the Laboratory, including Pajarito Canyon from North Anchor East basin (“Arroyo de la Delfe”) upstream into the south fork of Pajarito Canyon (“Starmers Gulch”) and Starmers Spring, are classified as perennial in NMAC 20.6.4.126, with designated uses of coldwater aquatic life, livestock watering, wildlife habitat, and secondary contact. The remaining segments in the Pajarito watershed within the Laboratory boundary are designated ephemeral or intermittent in NMAC 20.6.4.128, with designated uses of limited aquatic life, livestock watering, wildlife habitat, and secondary contact.

The numeric water-quality criteria (WQC) for livestock watering (NMAC 20.6.4.900.[F], [J]), wildlife habitat (NMAC 20.4.6.900.[G], [J]), acute aquatic life (NMAC 20.6.4.900.[H], [I], and [J]) human health (persistent) (NMAC 20.6.4.11[G]; NMAC 20.4.6.900.[J]), and secondary contact (NMAC 20.6.4.900[E]) apply to nonstormwater for all of the watercourse classifications. For classified ephemeral/intermittent segments, the WQC for acute aquatic life (NMAC 20.6.4.900.[H], [I], and [J]) and acute total ammonia (20.6.4.900[K]) also apply. For classified perennial segments, the WQC for acute aquatic life (NMAC 20.6.4.900.[H], [I], and [J]), chronic aquatic life (NMAC 20.6.4.900[H], [I], [J]), human health (NMAC 20.6.4.11[G]; 20.4.6.900.[J]), acute total ammonia (NMAC 20.6.4.11[E](2); 20.6.4.900[K]), and chronic total ammonia (NMAC 20.6.4.900[M]) also apply. Comparisons of water data to applicable standards are summarized in Section 6.

Stormwater discharges are regulated under the CWA, and no applicable standards for stormwater are provided in the Consent Order. For informational purposes, available stormwater monitoring data for the Pajarito watershed are compared with surface wSALs established under the FFCA/AO. The wSAL is designated as the lowest numeric criterion of the applicable NMWQCC WQC, if one exists. The wSALs for each contaminant are determined in stepwise fashion by evaluating, in the following order:

- requirements for any FFCA-monitored segment that is included in a classified water of the state in 20.6.4.101 through 20.6.4.899 NMAC
- requirements for any FFCA-monitored surface water that is not included in a classified water of the state in 20.6.4.101 through 20.6.4.899 NMAC
- MSGP benchmark values for Sector K, Hazardous Waste Treatment, Storage, or Disposal Facilities.

Derivation of the current EPA-approved wSAL values is described in the Laboratory “Storm Water Pollution Prevention Plan for SWMUs and AOCs (Sites) and Storm Water Monitoring Plan, Annual Update–2007” (LANL 2007, 096981).

Concentrations of radionuclides in surface water were compared with the following values to identify COPCs:

- DCG based on 100 mrem/yr

To identify COPCs in groundwater, comparisons to the lowest of the following standards were performed:

- Human Health (NMAC 20.6.2.3103.A: Human health standards)
- Other Standards for Domestic Water (NMAC 20.6.2.3103.B: Other standards for domestic water supply)
- EPA maximum contaminant levels (MCLs)

If none of the above standards exist for an analyte, the following values were compared with concentrations in groundwater to identify COPCs:

- DCG based on 4 mrem/yr
- EPA Region 6 tap water screening levels (EPA 2007, 099314)

Comparisons of stormwater concentrations to wSALs are provided in Appendix F.

6.0 CANYONS CONTAMINATION

This section describes the methodology and results of analytical data-screening assessments for samples collected to identify COPCs in sediment, surface water, groundwater, and alluvial core samples. Identifying COPCs forms the basis for evaluating contamination in canyons media. COPCs identified in this section are evaluated in the human health risk assessment in Section 8.2 and have been considered in developing the measures evaluated in the baseline ecological risk assessment in Section 8.1. A subset of these COPCs is discussed in the conceptual model in Section 7. Section 6.1 briefly describes how the data were prepared for the screening processes. Section 6.2 presents the screens for sediment, Section 6.3 presents the screens for surface water and groundwater, and Section 6.4 presents the screens for alluvial core samples. The term “sediment” includes all post-1942 sediment deposits in the canyon bottoms, including deposits in abandoned channels and floodplains as well as in active stream channels; therefore, sediment includes alluvial soil as defined in some other studies.

6.1 Data Preparation

The data used in the assessments were obtained from the Environmental Restoration Database and the Water Quality Database (Attachment 1. Summaries of analytical data for all media are presented in Attachment 2. Samples collected, analytical methods used, and data qualifiers are presented in Appendix C. Sample locations may be referred to by more than one name, and a crosswalk showing synonyms for location names is presented in Table 6.1-1.

Certain analytical results were not evaluated in the screens and subsequent risk assessments for the following reasons.

- Duplicate sample results for analytes analyzed by a less sensitive method—For example, semivolatile organic compound (SVOC) results from samples that were also analyzed by a volatile organic compound (VOC), PAH, or high explosives (HE) analytical method. The duplicate results from the SVOC method are excluded from the screen because the VOC, PAH, and HE analytical methods provide lower detection limits. These duplicates can occur either (1) because analytes within a sample were analyzed by more than one method or (2) a location was resampled and analyses were obtained using more sensitive methods. Samples that had analyses replaced by “resamples” are shown in Table 6.1-2.
- SVOC analytical method results for PAHs from sediment samples collected in 2000—All but one of the reaches from which these samples were collected have been sampled more recently and results were obtained by the more sensitive PAH analytical method. Although the samples were not obtained at identical locations, the reaches have been adequately characterized by the more sensitive results (minimum of 10 samples). As a result, the less sensitive 2000 SVOC results are not used in the COPC screen and risk assessments. The one exception to this is reach TH-3, for which there are only SVOC results from 2000, and these were used in the screens.

- Field duplicate results—Results are from samples obtained for quality assurance/quality control (QA/QC) purposes and not as primary characterization data.
- Results from a subset of sediment samples collected to support the ecological risk assessment in Section 8.1—These samples were excluded from the COPC screens and from the subsequent human health risk assessment because they are from overlapping depths with previously sampled sediment layers and are therefore duplicates.
- Results from water samples collected before 2003—Results from samples collected in 2003 and later are used in the COPC screens because these data are most representative of current site conditions. Pre-2003 data are used in the trend analyses presented in the conceptual model in Section 7.2.

6.2 Sediment COPCs

This section presents the process for screening analytical results obtained from sediment samples collected in the Pajarito watershed. Samples collected and analyses performed by the analytical laboratories are presented in Table C-2.0-1 in Appendix C. Sample locations are presented in Plates 2 to 6. Analytical results were screened to develop a list of COPCs, as presented in Section 6.2.1.

6.2.1 Identification of Sediment COPCs

Inorganic chemical and radionuclide COPCs in sediment are identified by a screening process that includes comparing the maximum concentrations by reach with Laboratory-specific sediment background values (BVs) (LANL 1998, 059730). Analytes are retained as COPCs using rules specific to the class of analyte. This process is discussed below.

For inorganic chemicals, an analyte is retained as a COPC in a reach if

- the analyte has a BV and a detected or nondetected result in the reach exceeds the BV, or
- the analyte does not have a BV, but at least one detected result is in the reach.

For radionuclides, an analyte is retained as a COPC in a reach if

- the analyte has a BV and at least one detected result in the reach exceeds the BV, or
- the analyte does not have a BV but has at least one detected result in the reach.

There are no BVs for organic chemicals, and retaining an organic chemical as a COPC is based on detection status. For organic chemicals, an analyte is retained as a COPC in a reach if there is at least one detected result in the reach.

A total of 26 inorganic chemicals, 103 organic chemicals, and 11 radionuclides were retained as COPCs in sediment in the Pajarito watershed. Maximum sample results in each reach for these COPCs are presented in Tables 6.2-1, 6.2-2, and 6.2-3 for inorganic chemicals, organic chemicals, and radionuclides, respectively.

6.2.2 Comparison of Sediment COPC Concentrations to Residential SSLs and SALs

Maximum concentrations (including detection limits for inorganic chemicals) of sediment COPCs in each reach were compared with residential SSLs for inorganic and organic chemicals or residential SALs for radionuclides to identify which are most important for understanding potential human health risk. Four inorganic COPCs, three organic COPCs, and one radionuclide COPC have maximum concentrations

exceeding residential SSLs or SALs in the Pajarito watershed, and these are included in the conceptual model for sediment in Section 7.1. These COPCs are highlighted in gray in Tables 6.2-1, 6.2-2, and 6.2-3.

6.3 Surface Water and Groundwater COPCs

This section presents the process for screening surface water and groundwater sample results from the Pajarito watershed. Water samples collected and analyses performed by the analytical laboratories are presented in Tables C-2.0-2 and C-2.0-3 in Appendix C. Sample locations are presented in Figure 3.2-1 and Plate 1. Analytical results from water samples were screened to develop a list of COPCs, as presented in Section 6.3.1.

6.3.1 Identification of Surface Water and Groundwater COPCs

There are no BVs for surface water data, and COPCs are identified by a screening process that is based only on the detection status. This process is performed for groups of data defined by field preparation (filtered or nonfiltered samples) and analyte type (inorganic chemicals, organic chemicals, and radionuclides). An analyte is retained as a COPC for a location if it has at least one detected result.

Groundwater COPCs are identified by a screening process that includes comparing the maximum chemical concentrations with Laboratory-specific groundwater BVs (LANL 2007, 096665). An analyte is retained as a COPC if the analyte has a BV and a result for that analyte exceeds the BV. If the analyte does not have a BV, it is retained as a COPC if it is detected.

A total of 43 inorganic chemicals, 76 organic chemicals, and 16 radionuclides were retained as COPCs in water in the Pajarito watershed. Maximum sample results for surface water and groundwater are presented in Tables 6.3-1 to 6.3-20.

6.3.2 Comparison of Water COPC Concentrations to Standards

Maximum detected concentrations of water COPCs were compared with applicable water quality standards, as discussed in Section 5, to identify which are most important from a regulatory perspective. Nine inorganic COPCs and 11 organic COPCs in the Pajarito watershed have maximum concentrations exceeding a water quality standard. These COPCs are highlighted in gray in Tables 6.3-1 to 6.3-20.

6.4 Core Sample COPCs

This section presents the process for screening analytical results obtained from alluvial core samples collected in the Pajarito watershed. Samples collected and analyses performed by the analytical laboratories are presented in Table C-2.0-4 in Appendix C. Sample locations are presented in Figure 3.2-1 and Plate 1. Analytical results were screened to develop a list of COPCs as presented in Section 6.4.1.

6.4.1 Identification of Alluvial Core COPCs

The COPCs in alluvial core samples are identified by a screening process that includes comparing the maximum inorganic chemical or radionuclide concentrations by location with Laboratory-specific ALLH (“all horizons”) soil BVs (LANL 1998, 059730). Analytes are retained as COPCs using rules specific to the class of analyte. This process is discussed below.

For inorganic chemicals, an analyte is retained as a COPC if

- the analyte has an ALLH BV and a detected or nondetected result exceeds the BV, or
- the analyte does not have an ALLH BV, but there is at least one detected result.

For radionuclides, an analyte is retained as a COPC if

- the analyte has an ALLH BV and at least one detected result exceeds the BV, or
- the analyte does not have an ALLH BV but has at least one detected result.

There are no BVs for organic chemicals, and retaining an organic chemical as a COPC is based on detection status. For organic chemicals, an analyte is retained as a COPC if there is at least one detected result.

A total of 17 inorganic chemicals, 5 organic chemicals, and 3 radionuclides were retained as COPCs in alluvial core samples in the Pajarito watershed. Maximum sample results at each location for these COPCs are presented in Tables 6.4-1, 6.4-2, and 6.4-3 for inorganic chemicals, organic chemicals, and radionuclides, respectively.

6.5 Summary

Table 6.5-1 presents a summary of the COPCs in sediment, water, and alluvial core in the Pajarito watershed to allow comparisons between media. Table 6.5-1 also indicates which COPCs have maximum results in the watershed exceeding residential SSLs and SALs for sediment and water quality standards for surface water and groundwater.

7.0 PHYSICAL SYSTEM CONCEPTUAL MODEL

This section discusses aspects of the physical system conceptual model that are relevant for understanding the nature, sources, extent, fate, and transport of contaminants in the Pajarito watershed. The discussion on contaminants focuses on COPCs shown to be most important for evaluating potential present-day human health risk based on the comparisons with residential SALs and SSLs for sediment and water-quality standards for surface and groundwater in Section 6 and that represent known contaminant releases into the watershed. These COPCs are included in evaluations of potential human health risk in Section 8.2. This section also includes a discussion of COPCs identified as study design COPECs, which are relevant for evaluating potential present-day ecological risk. Some additional COPCs are discussed to provide historic insights into the sources and trends of contaminants or to present other important information about the watershed. As used in this section, “contaminant” refers to COPCs known to represent releases from Laboratory SWMUs or AOCs or other anthropogenic sources, whereas “COPC” is a more general term that also includes analytes identified in Section 6 that may or may not represent such releases.

The following discussion is divided into two sections. Section 7.1 uses spatial variations in COPC concentration in sediments to identify sources, describes the distribution of contaminants derived from Laboratory sources, and discusses fluvial processes controlling their distributions. Section 7.2 describes the hydrology of the watershed, including descriptions of surface water, alluvial groundwater, pore water, intermediate perched groundwater, and regional groundwater and summarizes spatial and temporal trends for contaminants in these media. Supporting information related to trends in contaminant distribution that supports the conceptual model is presented in Appendix D.

7.1 COPCs in Sediments

The following sections first use spatial variations in concentrations of sediment COPCs in the Pajarito watershed to identify sources, in part distinguishing COPCs that are present because of releases from Laboratory SWMUs or AOCs from COPCs derived from other sources, such as ash from the Cerro Grande burn area, runoff from roads or other developed areas, or natural background variations. Because of mixing of sediment from various sources during transport, contaminant concentrations are generally highest near the point of release and decrease downcanyon (e.g., Marcus 1987, 082301; Graf 1996, 055537; LANL 2004, 087390; Reneau et al. 2004, 093174; LANL 2006, 094161). Therefore, the spatial distribution of contaminants can directly indicate their source or sources. In most reaches in the Pajarito watershed, pre- and post-fire sediment layers can be distinguished based on the presence of in situ or reworked ash at varying depths. Recording the effects of redistribution of ash from the burn area are COPCs that are elevated above BVs in post-fire sediment in the burn area and downcanyon but not in pre-fire sediment near potential Laboratory sources. In contrast, COPCs that are elevated because of natural variations in background concentration generally show no distinct spatial trends and may have no significant differences in concentration between pre-fire and post-fire sediment. Figures D-1.1-1, D-1.1-2, and D-1.1-3 in Appendix D show all sample results for all COPCs plotted against distance from the Rio Grande, which help to identify sources and possible outliers in the data set.

7.1.1 Inorganic Chemicals in Sediments

Three inorganic chemicals detected in sediments in the Pajarito watershed have maximum concentrations greater than residential SSLs and are most important for assessing potential human health risk: arsenic, iron, and vanadium. Based on the comparison to residential SSLs in Section 6.2.2, six other inorganic COPCs are also identified as potentially contributing to risk: aluminum, cadmium, lead, manganese, silver, and thallium. Additional inorganic chemicals detected in sediment samples are important for assessing potential ecological risk (antimony, barium, chromium, copper, cyanide, mercury, perchlorate, selenium, and zinc) (LANL 2006, 093553). The spatial distribution of these inorganic chemicals (discussed below) indicates that they are derived from a variety of sources, including Laboratory SWMUs or AOCs, ash from the Cerro Grande burn area, roads and other developed areas, and naturally occurring soils and bedrock. Once in the canyon bottoms, most of these inorganic chemicals adsorb to sediment particles and organic matter (Salomons and Forstner 1984, 082304) and can be remobilized by floods that scour the stream bed or erode banks, being transported varying distances downcanyon.

This section focuses on spatial variations in inorganic chemicals in the Pajarito watershed. Supporting information is included in Appendix D. Table D-1.2-1 presents average concentrations in each reach for inorganic chemicals discussed in this section, substituting one-half of the detection limit for nondetected sample results. Table D-1.2-1 presents the upper and lower bounds on these averages using either the detection limit or zero for nondetects, respectively, which indicate uncertainties in the average values. This table shows that on average, concentrations of these inorganic chemicals are generally lower in coarse facies sediment than in fine facies sediment, as found in other watersheds (LANL 2004, 087390; LANL 2006, 094161). Figure 7.1-1 and the discussions in the following sections focus on data from fine facies sediment. Figure 7.1-1 and Table D-1.2-1 also show the uncertainty in the average concentration of some inorganic chemicals that exists in some reaches because of elevated detection limits and/or detected concentrations close to detection limits. For three inorganic chemicals that are elevated in Cerro Grande ash (barium, cyanide, and manganese), Table D-1.2-1 distinguishes concentrations in pre- and post-fire sediment in each reach.

The plots in Figure 7.1-1 include both the BV for each inorganic chemical, which is an estimate of the upper level of background concentrations, and the average value from the background sediment data set, where available (averages from McDonald et al. 2003, 076084, Table 10, pp. 49-50). The background averages are included to be consistent with the presentation of averages from potentially contaminated samples, although averages for fine facies sediment are expected to be higher than the entire background data set, which also includes coarse facies samples. For reaches where an inorganic chemical is not a COPC, the average background concentration is plotted in Figure 7.1-1. The spatial distribution of inorganic chemicals indicates that several TAs have been important Laboratory sources for these COPCs in the Pajarito watershed, as discussed below.

Aluminum is an important COPC for evaluating potential human health risk in the Pajarito watershed and is also important for evaluating water quality, as surface-water samples on the Pajarito Plateau are commonly above the NMWQCC acute aquatic life standard for dissolved aluminum (e.g., LANL 2007, 098644, p. 213). Many of the investigation reaches (15 of 32) have maximum concentrations of aluminum above the sediment BV of 15,400 mg/kg, although none are above the residential SSL of 77,800 mg/kg. The highest concentration, 34,700 mg/kg, was measured in reach PA-5W east of the Laboratory and downcanyon from the community of White Rock, indicating a non-Laboratory source for this aluminum. Only three reaches (AW-1, PA-4, and TH-1E) have average aluminum concentrations in fine facies sediment above the BV, as shown in Figure 7.1-1. No clear spatial trends are indicated in these data that would indicate significant Laboratory sources for aluminum, and the aluminum above BVs probably largely represents natural background variations.

Antimony was indicated to be an important COPC for evaluating potential ecological risk in the Pajarito watershed, based on comparison of maximum sample results to ESLs (LANL 2006, 093553). However, it has only a single detected result above the sediment BV of 0.83 mg/kg, 0.95 mg/kg in reach PA-4. This result is relatively close to the BV and probably represents background variations and not Laboratory releases.

Arsenic is the most important inorganic chemical for evaluating potential human risk in the Pajarito watershed, with maximum concentrations being greater than the sediment BV of 3.98 mg/kg and the residential SSL of 3.9 mg/kg in 17 of the 32 investigation reaches. (Note: Because of an elevated local background for arsenic on the Pajarito Plateau, the sediment BV is above the residential SSL.) Average concentrations of arsenic in fine facies sediment are greater than the sediment BV in three reaches: AW-1, TH-1E, and TWSW-1W. Only AW-1 has an average concentration more than 10% higher than the BV, approximately twice the BV (7.92 mg/kg). AW-1 also has the maximum measured concentration in the Pajarito watershed, 20 mg/kg, over twice the soil BV of 8.17 mg/kg. These data indicate releases of arsenic from one or more sites at TA-08, consistent with evidence for releases of other inorganic and organic COPCs from TA-08, as discussed elsewhere in Section 7.1. In other parts of the Pajarito watershed, there are no recognizable spatial trends in arsenic concentration that clearly identify sources, as shown in Figure 7.1-1, and the sample results above the sediment BV may represent either small releases from Laboratory activities or locally elevated background.

Barium is an important COPC for evaluating potential ecological risk in the Pajarito watershed, with maximum concentrations being greater than the sediment BV of 127 mg/kg in most of the investigation reaches (26 of 32). The spatial distribution of barium indicates multiple sources, including releases from Laboratory sites, ash from the Cerro Grande burn area, and possibly elevated natural background concentrations. The maximum barium concentration (874 mg/kg) was measured in reach AW-1, similar to other COPCs, and indicates releases from TA-08. The second highest concentration (738 mg/kg) was measured in an ash-rich post-fire sediment sample from reach PA-4, which is consistent with data from other areas that indicate barium is elevated in Cerro Grande ash above the sediment BV (Katzman et al.

2001, 072660; Kraig et al. 2002, 085536; LANL 2004, 087390). Average concentrations of barium in fine facies sediment in the investigation reaches are shown in Figure 7.1-1 and indicate that barium is also elevated in post-fire sediment in the two reaches west of the Laboratory: PA-0 and TW-1W. The maximum barium concentrations in the downcanyon reaches PA-3E and PA-5W are also in ash-rich samples, indicating a Cerro Grande effect. In contrast, elevated barium in non-fire-affected sediment in other reaches suggests smaller releases from other Laboratory sites in addition to TA-08, including TA-09 (reaches AEN-1 and AES-1), TA-15 (reach THW-1), and TA-69 (reach TW-1E). Barium had previously been reported as a COPC at both TA-08 and TA-09 (LANL 1998, 059577, p. 2-11). Barium is used in various explosives, and its release from these TAs is consistent with their history of weapons development. Some of the elevated barium concentrations in pre-fire sediment may be caused by a locally elevated natural background, such as in reach PA-4, as seen in the nearby watershed of Cañada del Buey (Drakos et al. 2000, 068739, p. 32). Notably, the maximum barium concentration in the Pajarito watershed (in AW-1) was in a coarse-grained sediment sample, and average concentrations in coarse facies sediment in this reach close to the source are higher than in fine facies sediment, as shown in Table D-1.2-1 in Appendix D.

Cadmium is an important COPC for evaluating potential human health risk in the Pajarito watershed and has maximum detected concentrations above the sediment BV of 0.4 mg/kg in half of the investigation reaches (16 of 32). Figure 7.1-1 shows the spatial distribution of cadmium in fine facies sediment in the watershed and indicates that TA-09, upcanyon from reach AEN-1, is the most important Laboratory source. AEN-1 has both the highest measured concentration in the watershed, 4.74 mg/kg, and the highest average concentration. Cadmium remains elevated above the BV in the next two downcanyon reaches, PA-1E and PA-2W, but is generally within the range of background concentrations farther downcanyon. However, cadmium remains a COPC to the farthest downcanyon reach, PA-5W, indicating possible transport of cadmium from TA-09 into lower Pajarito Canyon below White Rock. A secondary source for cadmium is evident at TA-08, upcanyon from reach AW-1, but cadmium is generally within background ranges in the next downcanyon reach (PAS-2W). Cadmium has previously been reported as a COPC at both TA-08 and TA-09 (LANL 1998, 059577, p. 2-11).

Chromium is a widespread COPC in the Pajarito watershed, and roughly half of the investigation reaches (17 of 32) have maximum concentrations above the sediment BV of 10.5 mg/kg. It is a potentially important COPC for assessing ecological risk (LANL 2006, 093553). Chromium has an irregular spatial distribution in the Pajarito watershed, suggesting a variety of dispersed sources (Figure 7.1-1). The highest average concentration in fine facies sediment are in the south fork Pajarito Canyon basin in reach AW-1, below TA-08, and the adjacent reach PAS-1E also has average chromium concentrations in fine facies sediment above the BV. Relatively small releases of chromium from TA-09, TA-15, and TA-22 are indicated by elevated concentrations in reaches AEN-1, TH-1E, and TWSE-1W, respectively (Figure 7.1-1). Chromium has previously been reported as a COPC at both TA-08 and TA-09 (LANL 1998, 059577, p. 2-11). Chromium is a COPC in all reaches in Pajarito Canyon except PA-0 and PA-4E, and one downcanyon reach, PA-4, has average chromium concentration in fine facies sediment above the sediment BV. This distribution indicates possible transport from upcanyon TAs into lower Pajarito Canyon below White Rock.

Copper is a widespread COPC in the Pajarito watershed, and roughly half of the investigation reaches (17 of 32) have maximum concentrations above the sediment BV of 11.2 mg/kg. It is a potentially important COPC for assessing ecological risk (LANL 2006, 093553) and is also present in a dissolved form above surface-water standards (LANL 2007, 098644, pp. 213-214). Copper has an irregular spatial distribution in the Pajarito watershed, suggesting a variety of dispersed sources (Figure 7.1-1). The highest average concentration in fine facies sediment was found in the upper part of the southeast fork of Twomile Canyon (reach TWSE-1W), below a developed area at TA-22. However, copper concentrations

are not elevated above the BV downcanyon in Twomile Canyon, indicating relatively small releases from this site. In the Threemile watershed, copper concentrations are highest in the middle fork (reach THM-1), immediately downcanyon from the R-44 firing site [(SWMU 15-006(c)], but copper is not above the BV farther downcanyon. Average copper concentrations are also above the BV in the south fork of Threemile Canyon (reaches THS-1W and THS-1E), downgradient of the E-F and R-44 firing sites [(SWMUs 15-004(f) and 15-006(c)], respectively. Similar to other metals, the average copper concentration is above the BV in the south fork Pajarito Canyon basin in reach AW-1, indicating a source at TA-08, but copper is not a COPC farther downcanyon in the south fork. Copper is also elevated in the north Anchor East basin (reach AEN-1) and in several reaches along the main channel of Pajarito Canyon, notably PA-1E, PA-2W, and PA-4, suggesting additional dispersed sources and downcanyon transport. The spatial distribution suggests releases of copper from TA-09, TA-22, and TA-40, although the nature of the releases is not certain.

Cyanide is an important COPC for evaluating potential ecological risk in the Pajarito watershed and has maximum concentrations above the sediment BV of 0.82 mg/kg in 12 of the investigation reaches. Its spatial distribution indicates both releases from the Laboratory and an association with ash from the Cerro Grande burn area. The highest concentration, 6.52 mg/kg, was measured in pre-fire sediment in reach TWSE-1W in the southeast fork of Twomile Canyon downcanyon of TA-22, indicating releases from this site. The average concentration in fine facies pre-fire sediment is also greater than the BV in this reach (Figure 7.1-1). Besides TWSE-1W, all reaches with elevated cyanide are associated with post-fire sediment, indicating a source in ash from the Cerro Grande burn area. Cyanide is also elevated in post-fire sediment samples and stormwater collected from other burned watersheds not affected by Laboratory activities (Gallaher and Koch 2004, 088747, pp. 44-46; LANL 2004, 087390, Figure D-1.7-1, p. D-40).

Iron is the second most important inorganic chemical for evaluating potential human risk in the Pajarito watershed, with maximum concentrations being greater than the sediment BV of 13,800 mg/kg in half of the investigation reaches (16 of 32) and greater than the residential SSL of 23,500 mg/kg in 4 reaches. The spatial distribution of iron is very similar to that of aluminum, discussed above, with average concentrations in fine facies sediment exceeding the BV in reaches AW-1, PA-4, PAS-1E, and TH-1E (Figure 7.1-1). No clear spatial trends are indicated in these data that would indicate significant Laboratory sources for iron, and most of the iron results above the BV may represent a locally elevated background, as also found in Cañada del Buey, the next canyon north of lower Pajarito Canyon (Drakos et al. 2000, 068739).

Lead is an important COPC for evaluating potential human health risk in the Pajarito watershed and has maximum concentrations exceeding the sediment BV of 19.7 mg/kg in half of the investigation reaches (16 of 32). Average lead concentrations in fine facies sediment exceed the BV in six reaches, as shown in Figure 7.1-1, and indicate several sources. The highest average concentrations occur in reach AW-1 downgradient of TA-08, similar to several other metals, indicating probable releases from this site. The second highest average concentrations occur in reach THM-1, immediately downcanyon from the R-44 firing site [(SWMU 15-006(c)], consistent with the known use of lead in open-air tests at R-44 (LANL 1998, 059577, p. 2-25). In contrast, elevated results in other reaches indicate non-Laboratory sources. For example, lead concentrations are elevated in reach TWN-1W, upgradient from Laboratory SWMUs and AOCs but downgradient of NM 501, indicating a source in road runoff. Lead is a common contaminant found below roads and other developed areas, and one source is leaded gasoline (Walker et al. 1999, 082308, p. 364; Breault and Granato 2000, 082310, p. 48; Callender and Rice 2000, 082307, p. 232). Other reaches with elevated lead downgradient of major roads include TW-1E, PA-3E, and PA-4.

Manganese is an important COPC for evaluating potential human health risk and has maximum concentrations above the sediment BV of 543 mg/kg in most investigation reaches in the Pajarito watershed (20 of 32). The spatial distribution of manganese indicates that the most important source in the watershed is ash from the Cerro Grande burn area, although many samples from non-fire-affected sediment also have manganese concentrations above the BV. Average concentrations of manganese in fine facies sediment are significantly higher in post-fire samples than in pre-fire samples in many reaches, as shown in Figure 7.1-1. These relations are consistent with previous studies that also identified manganese as being elevated in ash-rich sediment in comparison to pre-fire background (Katzman et al. 2001, 072660; Kraig et al. 2002, 085536; LANL 2004, 087390). Average concentrations are slightly above the BV in pre-fire sediment in two reaches: TW-1W, west of the Laboratory, and PA-4, west of NM 4 (Figure 7.1-1), the former documenting a locally elevated background as also seen in Cañada del Buey (Drakos et al. 2000, 068739, p. 32). Concentrations above the BV in pre-fire samples suggest possible releases of manganese from several TAs (e.g., TA-06, TA-08, TA-09, TA-15, and TA-40), although the amounts would have been small as average concentrations are not significantly elevated.

Mercury is an important COPC for evaluating potential ecological risk in the Pajarito watershed and has maximum concentrations above the sediment BV of 0.1 mg/kg in two of the investigation reaches: AEN-1 and AW-1. Average concentrations in fine facies sediment are also greater than the BV in both of these reaches (Figure 7.1-1), indicating releases from TA-08 and TA-09. Because mercury is not a COPC in downcanyon reaches, the total releases were apparently small.

Perchlorate is an inorganic chemical with no sediment BV and no ESL and is discussed here because of the potential for ecological risk (LANL 2006, 093553). Perchlorate has a detection frequency of 12% in sediment in the Pajarito watershed, and the maximum detected concentration (0.0028 mg/kg in reach PA-2W) is within the range of detection limits for the full data set. Average concentrations in fine and coarse facies sediment in each reach show no spatial trends (Table D-1.2-1 in Appendix D), and detected concentrations are similar in reaches upcanyon from Laboratory SWMUs and AOCs (PA-0, TW-1W, and TWN-1W) and in downcanyon reaches. Therefore, the sediment data show no evidence of releases of perchlorate from Laboratory sites into the Pajarito watershed.

Selenium is an important COPC for evaluating potential ecological risk in the Pajarito watershed and has maximum detected concentrations above the sediment BV of 0.3 mg/kg in most investigation reaches (22 of 32). Evaluating the distribution of selenium is difficult because of a high frequency of nondetects (71%) and elevated detection limits, such that the average detection limit for nondetects (1.90 mg/kg) is more than twice than the average detected concentration (0.88 mg/kg). The maximum detected concentration, 4.39 mg/kg, was obtained from the background reach PA-0 west of NM 501, and selenium was also detected above the BV in the other two reaches upcanyon from SWMUs and AOCs (TW-1W and TWN-1W). Average selenium concentrations in coarse and fine facies sediment are presented in Table-D-1.2-1 in Appendix D, and this table also indicates the uncertainty in average concentrations associated with elevated detection limits. Considering the uncertainties, no spatial trends are apparent that would indicate significant Laboratory releases, and the sediment data suggest that selenium in the Pajarito watershed is largely or entirely naturally derived.

Silver is an important COPC for evaluating potential human health risk and has maximum concentrations above the sediment BV of 1.0 mg/kg in eight reaches. The spatial distribution of silver indicates clear sources at Laboratory sites. Average silver concentrations in fine facies sediment are highest in the south fork Pajarito Canyon basin immediately downgradient of TA-08 in reaches AW-1 and PAS-1E and remain elevated above the BV downcanyon to reach PA-2W. Photographic-processing facilities at TA-08 are the probable source of this silver. Average concentrations are also above the BV in reaches AEN-1 and

TW-1E, indicating releases from TA-09 and TA-69, although concentrations are much lower in these reaches and releases were apparently much smaller.

Thallium is an important COPC for evaluating potential human health and ecological risk in the Pajarito watershed. Thallium was detected only above the sediment BV of 0.73 mg/kg in only one reach, AEN-1, although 6 of 10 samples from this reach have concentrations above the BV. The average concentration in fine facies sediment in AEN-1 is also above the BV (Table D-1.2-1, Appendix D). These data indicate releases of small amounts of thallium into the north Anchor East basin from TA-09, with no recognizable impact farther east in Pajarito Canyon.

Total uranium is an important COPC for evaluating potential human health risk in the Pajarito watershed. Total uranium concentrations were calculated from the isotopic uranium data obtained in this study, and average concentrations for fine and coarse facies sediment are presented in Table D-1.2-1 in Appendix D for reaches where total uranium is a COPC. These data show the same general spatial pattern found for uranium-238 (discussed in Section 7.1-3), with all reaches in the Threemile watershed having average concentrations in fine facies sediment greater than the sediment BV of 6.99 mg/kg, and uranium being close to or below the BV in other reaches. The highest concentrations occur in reaches THS-1W (138 mg/kg) and THM-1 (153 mg/kg), in the south and middle forks of Threemile Canyon downcanyon from the E-F and R-44 firing sites, SWMUs 15-004(f) and 15-006(c), respectively. Total uranium is not a COPC farther downcanyon in Pajarito Canyon east of TA-18.

Vanadium is an important COPC for evaluating potential human health and ecological risk in the Pajarito watershed. It has maximum concentrations above the sediment BV of 19.7 mg/kg in most of the investigation reaches (20 of 32), and average concentrations in fine facies sediment are greater than the BV in 11 reaches (Figure 7.1-1 and Table D-1.2-1 in Appendix D). Maximum concentrations of vanadium occur in reach AW-1 below TA-08, and the average concentration in fine facies sediment in AW-1 is more than twice the BV, indicating releases from TA-08. Elsewhere in the Pajarito watershed, there are no clear spatial trends in vanadium concentrations. The elevated results at least in part represent naturally elevated background concentrations, as shown by concentrations above the BV in reaches PA-0 and TWN-1W upcanyon from Laboratory SWMUs and AOCs. Vanadium has also been identified as having a locally elevated background elsewhere on the Pajarito Plateau (Cañada del Buey reach CDB-4, Drakos et al. 2000, 068739).

Zinc is a potentially important COPC for evaluating ecological risk in the Pajarito watershed, and maximum concentrations are greater than the sediment BV of 60.2 mg/kg in 13 investigation reaches. The maximum zinc concentrations are in reach AW-1 below TA-08. Average zinc concentrations in fine facies sediment are above the BV in two reaches, AW-1 and PA-4, and are close to the BV in two more, PA-3E and TWN-1E (Figure 7.1-1). All of these areas receive runoff from large areas of paved roads and/or parking lots, and zinc is commonly found in urban runoff; one important source for zinc is tire-wear particulates (Walker et al. 1999, 082308, p. 364; Breault and Granato 2000, 082310, p. 49; Callender and Rice 2000, 082307, p. 232). The highest average zinc concentration in fine facies sediment in the Pajarito watershed is from AW-1, about 75 mg/kg, which is less than what is occurring in the upper parts of Acid, DP, and Mortandad Canyons (85–130 mg/kg), each of which also receives runoff from large paved areas (LANL 2004, 087390, p. 7-14; LANL 2006, 094161, p. 47). The spatial distribution of zinc therefore indicates that the primary source in the Pajarito watershed is runoff from roads and other developed areas.

7.1.2 Organic Chemicals in Sediments

Three organic chemicals detected in sediments in the Pajarito watershed have maximum detected concentrations greater than residential SSLs and are most important for assessing potential human health risk: the PCB Aroclor-1254 and the PAHs benzo(a)anthracene and benzo(a)pyrene. Based on the comparison to residential SSLs in Section 6.6.2, four other organic COPCs are also identified as potentially contributing to risk: Aroclor-1248, Aroclor-1260, benzo(a)fluoranthene, and naphthalene. Additional organic chemicals detected in sediment samples are important for assessing potential ecological risk [bis(2-ethylhexyl)phthalate and di-n-butylphthalate] or for understanding potential off-site transport (Aroclor-1242). These organic chemicals are derived from a variety of sources, including Laboratory SWMUs or AOCs and runoff from roads and other developed areas, as indicated by their spatial distribution (discussed below). Once in the canyon bottoms, most of these organic chemicals will adsorb to sediment particles and organic matter, and their subsequent fate and transport by fluvial processes is expected to be similar to that for inorganic chemicals. Some of the organic chemicals discussed in this section have relatively short environmental half-lives associated with biodegradation and/or volatilization in the environment. Therefore, the concentrations will decrease over time unless contaminants are added to the canyon bottoms (such as from road runoff). However, the degradation rates are not well constrained and will vary with local environmental conditions.

This section focuses on spatial variations in organic chemicals in the Pajarito watershed, and supporting information is included in Appendix D. Tables D-1.2-2 to D-1.2-7 present average concentrations in each reach for organic chemicals discussed in this section, substituting one-half of the detection limit for nondetected sample results. These tables also present the upper and lower bounds on these averages, using either the detection limit or zero for nondetects, respectively. These tables indicate that on average, concentrations of these organic chemicals are lower in coarse facies sediment than in fine facies sediment, and the discussions and figures in the following sections focus on data from fine facies sediment. Tables D-1.2-2 to D-1.2-7 also indicate that considerable uncertainty exists in the average concentration of organic chemicals in some reaches because of elevated detection limits and/or a high frequency of nondetects.

7.1.2.1 PCBs

PCBs have low solubilities and a strong affinity for organic material and sediment particles (Chou and Griffin 1986, 083419). PCBs were widely used in electric transformers and other industrial applications (e.g., Walker et al. 1999, 082308, pp. 364-365), and their widespread use is consistent with their spatial distribution in sediments in the Pajarito watershed. The sediment data indicate that PCBs were derived from multiple sources in the watershed and that concentrations generally decrease downcanyon from these sources, as discussed below.

Aroclor-1242 was detected only in single samples in each of two reaches: PA-5W in Pajarito Canyon east of White Rock and TWSW-1W in the southwest fork of Twomile Canyon. The highest concentration was measured in PA-5W, indicating a non-Laboratory source.

Aroclor-1248 was detected in 12 samples from four reaches: PA-5W, TW-1E, TW-2E, and TWN-1E. The highest concentrations were measured in TW-1E, immediately downcanyon from SWMU 69-001, a former incinerator ash pond in the Twomile watershed that has also been identified as a source for dioxins and furans, as discussed in Section 7.1.2.4. TWN-1E is downcanyon from large developed areas in TA-03, indicating one or more sources in this TA. The Aroclor-1248 detected downstream in TW-2E could have been derived from a combination of these sources. Lower concentrations were measured in PA-5W, indicating a separate, smaller source or sources in White Rock.

Aroclor-1254 and Aroclor-1260 are more widely distributed in the Pajarito watershed, and multiple sources are also indicated for these PCBs. Figure 7.1-2 presents average concentrations of Aroclor-1254 and Aroclor-1260 in fine facies sediment in the Pajarito watershed, substituting one-half of the detection limit for nondetected sample results and showing upper and lower bounds on these averages. The highest concentrations of both Aroclors were measured in reach AW-1 within the south fork of Pajarito Canyon watershed immediately below TA-08, indicating one or more sources at TA-08. This is the only reach with PCB concentrations above residential SSLs. Concentrations of PCBs decrease rapidly in the next downcanyon reach, PAS-2W.

The next highest concentrations of both Aroclor-1254 and Aroclor-1260 were measured in reaches TWN-1E and TW-2E, indicating one or more sources at TA-03. Detections of Aroclor-1260 in TW-1E indicate an additional smaller source at SWMU 69-001, as seen for Aroclor-1248. Detections of Aroclor-1254 and Aroclor-1260 in TWSW-1W, TWSW-1E, TWSE-1W, and TWSE-1E indicate additional sources in the southwest and southeast forks of Twomile Canyon. Concentrations remain elevated farther east in Twomile Canyon but at lower concentrations than seen closer to TA-03 (Figure 7.1-2).

Detections of Aroclor-1260 in reach AEN-1, in the north Anchor East basin below TA-09, indicate a source for PCBs at this TA. Farther downcanyon in Pajarito Canyon, an additional source at TA-18 is suggested by detections of both Aroclor-1254 and Aroclor-1260 in reach PA-3E, although estimated average concentrations in this reach are affected by elevated detection limits, as shown in Figure 7.1-2.

7.1.2.2 PAHs

PAHs have a range of chemical properties, with some being less volatile and less soluble, and these chemicals are more likely to become adsorbed to and persist in sediments (Neff 1979, 083420). Some PAHs, such as naphthalene, are relatively volatile and have the lowest affinity for sediments, whereas other PAHs, such as benzo(a)pyrene, are less volatile and less soluble and have a stronger affinity for sediments. The different PAHs also have somewhat different spatial distributions in the Pajarito watershed, indicating different sources, as discussed below. Considerable uncertainty exists in the average concentrations of PAHs in some reaches because of low detection frequencies and/or detected values at or below detection limits in other samples.

All four PAHs that are important for evaluating potential human health risk in the Pajarito watershed [benzo(a)anthracene, benzo(a)pyrene, benzo(b)fluoranthene, and naphthalene] and an additional PAH that is important for evaluating potential ecological risk (anthracene) have maximum concentrations in a single coarse-grained sediment sample from the active stream channel in the north fork of Twomile Canyon (reach TWN-1E), immediately below large paved areas in TA-03. The concentrations in this sample are >10 times higher than in all other samples from the watershed, and it was suspected that a fragment of asphalt was analyzed in the sample and that these concentrations were not representative of the stream channel sediments in this reach. Therefore, this location was resampled and two additional samples were collected from the active channel in TWN-1E. The original elevated results could not be reproduced, supporting the interpretation that the original results were not representative.

Excluding the anomalous coarse-grained channel sample from reach TWN-1E, PAHs in each reach have average concentrations in coarse facies sediment that are less than in fine facies sediment, as presented in Table D-1.2-3 of Appendix D. Table D-1.2-3 shows averages calculated using all samples, as well as a second set of averages for reach TWN-1E using the resample values, illustrating the effects of the single anomalous sample on the calculated averages. The spatial distribution of average concentrations of PAHs in fine facies sediment in the Pajarito watershed is plotted in Figure 7.1-3. Four of the five PAHs in these plots have similar spatial distributions, indicating similar sources and behavior: anthracene,

benzo(a)anthracene, benzo(a)pyrene, and benzo(b)fluoranthene. Estimated average concentrations in fine facies sediment for these four PAHs are highest in the north fork of Twomile Canyon below TA-03 (TWN-1E) and generally decrease downcanyon from TWN-1E, supporting a source from paved areas in TA-03. Drainage from tar roofs is another possible source of PAHs in runoff from developed areas. Relatively high concentrations were also measured farther downcanyon in Twomile Canyon (reach TW-2E), in reaches AEN-1 and AW-1 below large developed areas in TA-08 and TA-09, and locally in Pajarito Canyon adjacent to Pajarito Road (reaches PA-3E and PA-4). In contrast, one of these PAHs [benzo(a)anthracene] was detected in the largely undeveloped Threemile watershed in only a single sample, in reach TH-1E. The inferred source for these PAHs in developed areas in the Pajarito watershed is consistent with that seen previously in the Los Alamos and Pueblo watershed (LANL 2004, 087390, p. 7-16) and the Mortandad watershed (LANL 2006, 094161, pp. 48-49).

The remaining PAH that is important for evaluating potential human health risk, naphthalene, was detected in only three reaches in the Pajarito watershed (Table D-1.2.3 and Figure 7.1-3) and in a single sample in one of these reaches, TWN-1E. The TWN-1E detect was in the anomalous coarse-grained sample discussed previously, and naphthalene was not detected in the resample. In contrast to this isolated detect, naphthalene was detected in two samples from AW-1 and in four samples in the next downcanyon reach, PAS-2W, indicating a relatively small source at TA-08.

7.1.2.3 Other SVOCs

Besides PAHs, three other SVOCs are important in the Pajarito watershed for assessing potential ecological risk: benzoic acid, bis(2-ethylhexyl)phthalate, and di-n-butylphthalate (LANL 2006, 093553). Sources and average concentrations of these SVOCs are typically uncertain, as discussed below.

Benzoic acid was reported as detected in 10 investigation reaches in the Pajarito watershed, 7 of them in single samples. The maximum detected concentration was in a sample from the background reach PA-0, west of the Laboratory, and the detection frequency in this reach was 18% (2 of 11 samples), indicating either a natural source for this chemical or false positives from the analytical laboratory. Average concentrations in fine facies sediment are shown in Figure 7.1-4 and show no spatial trends that would indicate significant Laboratory sources. The highest average concentration shown in this figure, in reach TWSE-1E, results from elevated detection limits in three samples; the only detected result in this reach is below the detection limits for other samples. The estimated average concentrations in other reaches also have large uncertainty because of high frequencies of nondetects (95% in sediment samples in the watershed) and with detection limits that are similar to reported detected values.

Bis(2-ethylhexyl)phthalate was detected in five investigation reaches in the Pajarito watershed, although in two of these reaches there were only single detected results (PA-4 and TWN-1W). EPA identified bis(2-ethylhexyl)phthalate as a common laboratory contaminant (EPA 1989, 008021, p.5-16), which may explain some of the results, including the single detects in TWN-1W, upcanyon from Laboratory SWMUs or AOCs and in PA-4. The highest concentration, 1.27 mg/kg, and the highest detection frequency, 40%, are from reach THM-1 in the middle fork of Threemile Canyon below the R-44 firing site in TA-15 [(SWMU 15-006(c)]. The location with the highest concentration (TH-25024) was also resampled as part of the biota investigation; the original result was replicated, confirming releases from this site. Detection frequencies are 25% in reach AW-1 below TA-08 and 20% in reach TWSE-1E below TA-40, suggesting additional releases from these sites. As shown in Figure 7.1-4, the reaches with bis(2-ethylhexyl)phthalate detections are isolated from each other, with no evidence of significant downcanyon transport. The estimated average concentrations also have large uncertainty associated with high frequencies of nondetects (95% in sediment samples in the watershed) and detection limits that are similar to reported detected values.

Di-n-butylphthalate was detected in only five samples in three investigation reaches in the Pajarito watershed for a detection frequency of 1%. The two highest concentrations (0.27 and 1.54 mg/kg) were measured in reach AW-1 where the detection frequency was 10%, indicating small releases from TA-08. The next two highest concentrations were measured in reach PA-4 where the detection frequency was 14%, although these detected results (0.06 and 0.104 mg/kg) are below the detection limit for all other samples from this reach. There was also a single detected result from reach TWN-1E at a very low concentration (0.0486 mg/kg) that is also below the detection limits for all other samples from this reach. EPA identified di-n-butylphthalate as another common laboratory contaminant (EPA 1989, 008021, p. 5-16), suggesting that the results from PA-4 and TWN-1E may be false positives. As shown in Figure 7.1-4, the reaches with di-n-butylphthalate detections are isolated from each other, as seen for bis(2-ethylhexyl)phthalate, with no evidence of significant downcanyon transport. This figure also shows the large uncertainties in average concentration that are associated with low detection frequencies and detected results below detection limits for other samples.

7.1.2.4 Explosive Compounds

Twelve explosive compounds were detected in sediment in the Pajarito watershed. For 10 of these there are only single detects in specific reaches, and at least some of these appear to be false positives. Specifically, six of the explosive compounds (amino-2,6-dinitrotoluene[4-], amino-4,6-dinitrotoluene[2-], HMX, nitrobenzene, nitrotoluene[2-], and tetryl) had maximum detected concentrations reported from a single ash-rich post-fire sample from the background reach PA-0, west of NM 501, suggesting that the results may be partially an artifact of analytical interferences. Four of the explosive compounds had only single detects in the watershed (dinitrotoluene[2,6-] in reach TH-3; nitrotoluene[3-] in reach TW-2E; hexahydro-1,3,5-trinitro-1,3,5-triazine (RDX) in reach TWSE-1E; and trinitrotoluene[2,4,6-] in reach PA-2W). One of the explosive compounds was detected in two samples in one reach (dinitrotoluene[2,4-] in TW-2E) but not in upcanyon or downcanyon reaches.

The remaining explosive compound, triaminotrinitrobenzene (TATB), has a spatial distribution that indicates releases from TA-09 and downcanyon transport as far east as reach PA-3E, immediately east of TA-18. TATB is also the only explosive compound identified as important for assessing potential human health risk. Maximum concentrations for TATB were measured in reach AEN-1, and it was detected in 50% of the samples in this reach. TATB was also detected in the next three downcanyon reaches (PA-1E, PA-2W, and PA-3E) but not elsewhere in the Pajarito watershed. Table D-1.2-5 in Appendix D presents average concentrations of TATB in fine and coarse facies sediment and shows that concentrations are higher in fine-grained sediment than in coarse-grained sediment, as seen for other COPCs. Figure 7.1-5 presents average concentrations of TATB in fine facies sediment and shows downcanyon decreases below AEN-1, although there is considerable uncertainty in average concentrations in downcanyon reaches because of low detection frequencies and elevated detection limits.

7.1.2.5 Dioxins and Furans

Analyses for dioxins and furans in sediment were obtained from five investigation reaches in the Pajarito watershed and confirm a suspected source at SWMU 69-001, a former incinerator ash pond in the Twomile watershed, and also an additional source in the Cerro Grande burn area upcanyon from the Laboratory. Maximum concentrations of each dioxin and furan analyte were measured in pre-fire sediment deposits in reach TW-1E, immediately downcanyon from SWMU 69-001, but many of these analytes were also detected in reach TW-1W, west of NM 501, in an area dominated by post-fire sediment deposits. Table D-1.2-6 in Appendix D presents average concentrations of four categories of dioxins and furans (total pentachlorodibenzodioxins, total pentachlorodibenzofurans, total

tetrachlorodibenzodioxins [TCDDs], and total tetrachlorodibenzofurans [TCDFs]) in fine and coarse facies sediment in the five sampled investigation reaches. These values show that concentrations are higher in fine-grained sediment than in coarse-grained sediment, as seen for other COPCs.

Figure 7.1-6 presents average concentrations of two of these analytes, total TCDDs and total TCDFs, in fine facies sediment to illustrate their spatial distribution. TCDD is the dioxin and furan analyte that is most important for evaluating potential ecological risk and has the highest average concentration in TW-1E, but TCDD is also elevated in TW-1W. There is relatively little variation in TCDD concentrations between the five sampled reaches, and average concentrations in TW-1E are less than twice that in TW-1W, indicating that most of the TCDD may be derived from non-Laboratory sources (e.g., ash from the Cerro Grande burn area). In contrast, TCDF has low concentrations in TW-1W, relatively high concentrations in TW-1E, and progressively decreasing concentrations downcanyon (Figure 7.1-6), showing that TA-69 is the main source for this COPC. The data from the two downcanyon reaches, TW-4E and PA-3E, were from sediment deposited in the large flood of August 25, 2006, documenting concentrations carried in a significant flood event. (No samples were collected downcanyon from PA-3E after this event because associated sediment deposits were too thin to sample.)

7.1.2.6 Pesticides

One pesticide, DDT, has been identified as important for evaluating potential ecological risk in the Pajarito watershed (LANL 2006, 093553). DDT and other pesticides have low solubilities and a strong affinity for organic material and sediment particles (Pionke and Chesters 1973, 083423; Nowell et al. 1999, 083422). DDT was detected in 10 investigation reaches, with the highest detection frequency, 45% (5 of 11 samples), in background reach PA-0 west of the Laboratory. DDT was also detected in reach TW-1W, another background reach west of the Laboratory, which is consistent with documented spraying of DDT in the Santa Fe National Forest (LASL 1963, 064879). Additional sources probably exist at Laboratory TAs, resulting from historical pest-control use by Laboratory groundskeepers, as inferred in other watersheds (LANL 2004, 087390, p. 7-18; LANL 2006, 094161, p. 50). Average concentrations of DDT in fine facies sediment in the investigation reaches are shown in Figure 7.1-7, indicating that it is most commonly detected and has the highest concentrations in the western part of the Laboratory, although it has also been detected near the eastern Laboratory boundary (reach PA-4E) and farther east, below White Rock (reach PA-5W). Figure 7.1-7 also shows that there is considerable uncertainty in the average concentration of DDT in most reaches, which is associated with a high frequency of nondetects and detected values commonly below detection limits for other samples.

7.1.3 Radionuclides in Sediments

Radionuclides in sediments in the Pajarito watershed have several sources, as indicated by their spatial distribution. Sources include Laboratory firing sites, ash from the Cerro Grande burn area, and naturally occurring background. Subsequent discussions focus on the five radionuclides that are most important for the evaluation of potential human health risk, based on comparison to residential SALs in Section 6.2.2: cesium-137, plutonium-239,240, thorium-228, thorium-232, and uranium-238. No radionuclide COPCs have been identified as important for evaluating ecological risk (LANL 2006, 093553). Table D-1.2-8 in Appendix D shows average concentrations of these five radionuclides in fine and coarse facies sediment in each reach. For two fallout radionuclides that are elevated in Cerro Grande ash, cesium-137 and plutonium-239,240, Table D-1.2-8 distinguishes concentrations in pre- and post-fire sediment in each reach.

Two of the radionuclide COPCs that are potentially important for evaluating potential human risk, cesium-137 and plutonium-239,240, have been identified both as COPCs at SWMUs or AOCs in the Pajarito watershed (LANL 1998, 059577) and as being elevated above the sediment BV in Cerro Grande ash (Katzman et al. 2001, 072660; Kraig et al. 2002, 085536; LANL 2004, 087390). Figure 7.1-8 shows the spatial variations in average cesium-137 and plutonium-239,240 concentration in fine facies sediment in each reach, separated into pre-fire and post-fire samples, indicating that these radionuclides in the Pajarito watershed are dominated by ash from the Cerro Grande burn area. Average concentrations are only greater than the BV in post-fire sediment, including Pajarito Canyon west of the Laboratory (reach PA-0). The highest average concentrations of cesium-137 were found in the large wetlands in Pajarito Canyon west of NM 4 (reach PA-4) at >4 times the BV of 0.9 pCi/g, where thick layers of fine-grained ash-rich sediment were deposited in 2000. The highest average concentrations of plutonium-239,240 were found in Pajarito Canyon west of NM 501 (reach PA-0) at >10 times the BV of 0.068 pCi/g, in an area dominated by post-fire sediment.

The only radionuclide COPC with a maximum concentration exceeding the residential SAL is thorium-228. Thorium-228 was measured only above the sediment BV of 2.28 pCi/g and the residential SAL of 2.3 pCi/g in single samples in each of two reaches, PA-4 and THS-1E. The maximum result, 3.03 pCi/g from THS-1E, is 33% greater than the BV, and all results from the upcanyon reach closer to potential sources (THS-1W) are below the BV. The maximum result from PA-4, 2.37 pCi/g, is only 4% greater than the BV, and results from upcanyon reaches are all below the BV (except for the single sample in THS-1E). THS-1E is incised into Bandelier Tuff unit Qbt 1v, which has a relatively high BV for thorium-228 (3.75 pCi/g) (LANL 1998, 059730), indicating that the thorium-228 here is probably naturally occurring and derived from the local rock unit.

Similar to thorium-228, thorium-232 was measured only above the BV of 2.33 pCi/g in a single sample from THS-1E at a concentration of 2.57 pCi/g. This thorium-232 result from THS-1E is less than the Qbt 1v BV of 3.75 pCi/g (LANL 1998, 059730), also indicating a naturally elevated background in this area.

The remaining radionuclide COPC that is potentially important for evaluating potential human risk, uranium-238, is pervasively above background concentrations in reaches in the Threemile watershed and has a distribution that clearly indicates primary sources at firing sites, as shown in Figure 7.1-9. The highest average concentration was found in reach THS-1W in the south fork of Threemile Canyon, in proximity to the R-44 firing site [(SWMU 15-006(c)), and downcanyon from the E-F firing site [(SWMU 15-004(f)) in TA-15. Uranium has been previously shown to be a COPC at these firing sites (LANL 1998, 059577, p. 2-25). The second highest average concentration was found in reach THM-1 in the middle fork of Threemile Canyon and also in proximity to the R-44 firing site. The third highest average concentration was found in reach THS-1E downcanyon from THS-1W. Uranium-238 concentrations remain elevated in the next downcanyon reach, TH-3, in main Threemile Canyon, but concentrations are close to background levels farther downcanyon in reach PA-3E in Pajarito Canyon (Figure 7.1-9). Uranium-238 is also elevated farther west in the Threemile watershed in reaches TH-1C, TH-1E, and THW-1, although at much lower concentrations.

7.1.4 Summary of Sources and Distribution of Key Sediment COPCs

The data discussed in the previous sections indicate that the sediment COPCs in the Pajarito watershed have a variety of sources, including Laboratory SWMUs or AOCs, runoff from roads and other developed areas, ash from the Cerro Grande burn area, and natural background. Table 7.1-1 summarizes the inferred primary sources of the sediment COPCs discussed above and also the inferred downcanyon

extent of COPCs derived from Laboratory sources. Sources and downcanyon extent for these COPCs are discussed further below.

7.1.4.1 Upper Pajarito Watershed Sources

The sediment data indicate that TA-08 (Anchor West site) is a source for several contaminants in the upper Pajarito watershed above the confluence with Twomile Canyon, including the inorganic chemicals arsenic, barium, chromium, lead, mercury, silver, and vanadium, and the organic chemicals Aroclor-1254, Aroclor-1260, di-n-butylphthalate, and naphthalene (Table 7.1-1). Releases from TA-08 either entered a short drainage referred to as the Anchor West basin (reach AW-1) east of the main TA-08 facilities or the south fork of Pajarito Canyon (reach PAS-1E) to the north. The Anchor West basin has a small drainage area and reach AW-1 is dominated by fine-grained sediment. Many inorganic and organic COPCs in sediment have their maximum concentration in the Pajarito watershed in AW-1, as shown in Tables 6.2.1 and 6.2.2. Some of these have been identified as COPCs downcanyon in the south fork of Pajarito Canyon (reach PAS-2W), but others are COPCs in AW-1 but not in PAS-2W, indicating little downcanyon transport (e.g., chromium, lead, mercury, Aroclor-1260, and di-n-butylphthalate).

Silver is one COPC that has maximum concentrations in the Pajarito watershed below TA-08 and can be identified as extending farther downcanyon. Its spatial distribution is shown in Figure 7.1-10 to illustrate the effects of downcanyon transport and mixing on a contaminant derived from TA-08. TA-08 historically had photoprocessing facilities that discharged silver as part of a photochemical waste stream. Silver is elevated in both AW-1 and PAS-1E, as well as downcanyon in reaches PAS-2W, PA-1E, and PA-2W but not in the next reach downcanyon from TA-18 (PA-3E) or in lower Pajarito Canyon below White Rock (PA-5W). Figure 7.1-10 shows the variations in maximum silver concentration in each reach downcanyon from TA-08 and also averages in fine and coarse facies sediment, illustrating the generally higher concentrations in fine facies sediment. One exception to the occurrence of higher concentrations in fine-grained sediment, as compared with coarse-grained sediment, is in reach PAS-2W, close to the source, where the maximum measured silver concentration was in a coarse-grained sample from an abandoned post-1942 channel deposit. The relatively high concentrations in coarse-grained sediment here probably record the direct infiltration of silver-bearing effluent into the stream bed, as seen in reaches in other canyons that received liquid effluent (LANL 2004, 087390; LANL 2006, 094161).

The sediment data indicate that another source for contaminants in the upper Pajarito Canyon watershed is TA-09 (Anchor East site), including the inorganic chemicals cadmium, chromium, mercury, and thallium, and the explosive compound TATB. Cadmium, thallium, and TATB have their highest measured concentrations in the Pajarito watershed in reach AEN-1 in the north Anchor East basin below TA-09 and have variable spatial distributions. Thallium was detected only above the BV in AEN-1 and was not transported in high enough quantities to be identifiable as a COPC downcanyon in Pajarito Canyon. TATB was detected in the next three downcanyon reaches (PA-1E, PA-2W, and PA-3E), indicating transport past the confluences with Twomile and Threemile Canyons, but was not detected farther downcanyon (Figure 7.1-5). In contrast, cadmium was consistently detected above the sediment BV from AEN-1 to the farthest downcanyon reach, PA-5W below White Rock, except for reach PA-4E where relatively few samples were analyzed (Figure 7.1-1).

The distribution of cadmium downcanyon from TA-09 provides examples of both differences in concentrations of a contaminant between coarse-grained and fine-grained sediment and also the apparent effects of post-fire floods on contaminant redistribution. The upper plot in Figure 7.1-11 shows the higher average concentrations of cadmium in fine facies samples compared with coarse facies samples in the investigation reaches and also general downcanyon decreases in concentrations of both. Maximum concentrations, however, show more variability that is best explained by the effects of post-fire

floods, as presented in the lower plot in Figure 7.1-11. In pre-fire sediment deposits, cadmium shows progressive downcanyon decreases in maximum concentrations between AEN-1 and PA-3E, with concentrations in PA-3E and downcanyon being below the BV. In post-fire sediment deposits, maximum concentrations are relatively low near the source in reaches AEN-1 and PA-1E and then increase and remain relatively consistent downcanyon to PA-5W east of White Rock. Cadmium was not detected above the BV in post-fire sediment upcanyon from the Laboratory in reach PA-0, indicating that the presence of Cerro Grande ash cannot explain the higher concentrations in post-fire sediment in the lower canyon. Instead, this spatial pattern indicates that cadmium-bearing sediment deposits downcanyon from the north Anchor East basin were eroded by post-fire floods and that this sediment was transported downcanyon at least as far as PA-5W with relatively little mixing and dilution.

Chromium and copper were also identified as COPCs in reach AEN-1 and in all downcanyon reaches (excluding PA-4E), indicating that TA-09 was also a source for these metals in the Pajarito watershed. Figures 7.1-12 and 7.1-13 show the downcanyon distributions of chromium and copper, respectively, below TA-09. Both show similar spatial patterns to cadmium that have higher average concentrations in fine facies than in coarse facies sediment in each investigation reach and higher maximum concentrations in post-fire than in pre-fire sediment from PA-2W to PA-5W. As with cadmium, neither chromium nor copper is a COPC in the fire-affected background reach PA-0, indicating that the presence of Cerro Grande ash does not noticeably affect their concentrations. However, the distribution of copper differs from other contaminants released from TA-09 because it has the highest measured concentrations in downcanyon reaches in PA-2W. This suggests an additional source east of the north Anchor East basin, specifically firing sites at TA-40 on the north rim of Pajarito Canyon where copper has been reported as a COPC (e.g., [SWMUs 40-006 (a-c) and 40-009]; LANL 1998, 059577, p. 2-16).

7.1.4.2 Twomile Watershed Sources

In the Twomile watershed, the sediment data indicate that the main sources of COPCs from Laboratory sites are in TA-03, TA-22, and TA-69. Excluding reach AW-1 below TA-08, the highest detected concentrations of the PCBs Aroclor-1254 and Aroclor-1260 in the Pajarito watershed were measured in reach TWN-1E in the north fork of Twomile Canyon below TA-03. Aroclor-1260 was detected in each downcanyon reach below TWN-1E, except for PA-4E; its spatial distribution below TA-03 is shown in Figure 7.1-14. Although there is large uncertainty in the average concentration of Aroclor-1260 in some reaches associated with detection limits for some samples that are higher than detected values (e.g., reach PA-3E), decreasing concentrations are apparent downcanyon from TWN-1E, and concentrations are generally higher in fine facies sediment than in coarse facies sediment. In contrast to the difference in pre-fire and post-fire concentrations for metals released from TA-09, as discussed in Section 7.1.4.1, Aroclor-1260 shows no systematic difference between pre-fire and post-fire sediment, and it was not detected in post-fire sediment in some reaches (PA-4 and TW-4W). A possible source for PCBs released from TA-03 is SWMU 03-003(p), which was a storage area for electrical capacitors and transformers (LANL 1998, 059577, p. 2-20). A VCA was conducted here in 1995, removing contaminated soil (LANL 1998, 059577). Notably, although mercury has been one focus of attention at SWMU 03-0101(a) in TA-03 (LANL 1995, 046195; LANL 1998, 059577, pp. 3-59-3-60), it is not present above the BV downcanyon in the north fork of Twomile Canyon.

Reach TWSE-1W, in the southeast fork of Twomile Canyon below TA-22, had the highest measured concentrations of copper and cyanide in the Pajarito watershed, indicating releases from this site. The maximum measured copper concentration is above the BV in the next downcanyon reach, TWSE-1E, but is below the BV farther east in Twomile Canyon, indicating that the total releases of copper from TA-22 were small. Cyanide is not a COPC in TWSE-1E, indicating that the total releases of cyanide from TA-22 were also small.

Reach TW-1E in Twomile Canyon below TA-69 has the highest measured concentrations of the PCB Aroclor-1248 and dioxins and furans (e.g., TCDD and TCDF) in the Pajarito watershed, indicating releases from this site. SWMU 69-001, an incinerator ash pond with known releases into Twomile Canyon (LANL 1998, 059577, p. 2-13), is the probable source of these contaminants. Barium, lead, and silver also have their maximum concentrations in the Twomile watershed in TW-1E and are also inferred to be derived from SWMU 69-001. Silver was not detected above the BV farther east in Twomile Canyon, indicating relatively small releases and limited downcanyon transport. Aroclor-1248 was also detected in the next downcanyon reach, TW-2E, but not farther east in Twomile Canyon, also indicating relatively small releases. In contrast, TCDD and TCDF were detected in every downcanyon reach where these analyses were obtained (TW-2E, TW-4E, and PA-3E), indicating transport at least as far as PA-3E below TA-18, although the sediment data indicate that TCDD has a secondary source in the Cerro Grande burn area (Figure 7.1-6 and Section 7.1.2.5).

7.1.4.3 Threemile Watershed Sources

In the Threemile watershed, the sediment data indicate that the main sources of COPCs from Laboratory operations were firing sites in TA-15 [(SWMUs 15-006(c) and 15-004(f), also known as the R-44 and E-F firing sites, respectively)]. R-44 is located between the middle and south forks of Threemile Canyon (above reaches THM-1 and THS-1W, respectively), and its importance as a contaminant source is shown by the occurrence of the highest concentrations of some COPCs in the Pajarito watershed [e.g., bis(2-ethylhexyl)phthalate, lead, and uranium-238] or in the Threemile watershed (e.g., copper) in THM-1. THS-1W, downcanyon from both the E-F and R-44 firing sites, has the maximum concentration in the Pajarito watershed of total uranium and may have received contaminants from either or both of these sites.

Bis(2-ethylhexyl)phthalate, copper, and lead were not identified as COPCs in Threemile Canyon downcanyon from the middle and south forks in reach TH-3, indicating that releases of these contaminants from TA-15 were relatively small and that minimal downcanyon transport has occurred. In contrast, both total uranium and uranium-238 are COPCs in TH-3, indicating larger releases, although concentrations of both are at or near background levels in the next downcanyon reach (PA-3E). Figure 7.1-15 shows spatial variations in the concentrations of total uranium and uranium-238 below THS-1W and THM-1, respectively, to illustrate the effects of downcanyon mixing on the concentrations of these COPCs. Maximum and average concentrations of both decrease rapidly downcanyon between the sources and main Threemile Canyon. As with other COPCs, concentrations for both total uranium and uranium-238 are higher in fine facies sediment than in coarse facies sediment. Comparison of uranium-238 and uranium-235 concentrations in samples from the Threemile Canyon watershed indicates that the highest values are all depleted uranium, with uranium-238/235 ratios >21.72 (natural uranium), as shown in Figure 7.1-16.

7.1.4.4 Runoff from Roads and Other Developed Areas

Roads, parking lots, and other developed areas are the primary sources for several COPCs in sediment in the Pajarito watershed, including zinc and several PAHs, as discussed in previous sections. These sources are consistent with sediment data from other watersheds at the Laboratory (e.g., LANL 2004, 087390; LANL 2006, 094161) and with studies in other areas (e.g., Edwards 1983, 082302; Lopes and Dionne 1998, 082309; Walker et al. 1999, 082308; Breault and Granato 2000, 082310; Callender and Rice 2000, 082307; Van Metre et al. 2000, 082262). As discussed in Section 7.1.2.2, the highest concentrations of PAHs in the Pajarito watershed, greater than 10 times higher than in all other sample results, were measured in a coarse-grained active channel sample in the north fork of Twomile Canyon (reach TWN-1E), below large paved areas at TA-03. These anomalously high results could not be

replicated in other active channel samples from that reach or in a resample from the same location, supporting the hypothesis that a fragment of asphalt was included in the sample. The spatial variations in concentrations of PAHs indicate that runoff from TA-03 is the most important source in the Pajarito watershed, with PAHs being detected down the length of Twomile Canyon and into Pajarito Canyon. Runoffs from TA-08 and TA-09 are also notable sources, but the effect is more localized, with PAHs not being detected in Pajarito Canyon below these sites (reach PA-1E). Figure 7.1-17 illustrates the spatial variations in the PAH that is most important for evaluating potential human health risk, benzo(a)pyrene, downcanyon from TA-03 and TA-08, replacing results from the one anomalous sample from TWN-1E with results from the resample. Maximum and average concentrations decrease rapidly downcanyon from both TAs, remaining elevated through the length of Twomile Canyon but are not detected in main Pajarito Canyon upcanyon from Twomile Canyon (reaches PA-1E and PA-2W). The benzo(a)pyrene from TA-08 is apparently rapidly diluted with the larger volume of sediment in Pajarito Canyon, whereas in Twomile Canyon this PAH persists. This may indicate a larger source for PAHs at TA-03 than at TA-08 and/or an additional source in runoff from Pajarito Road and the other TAs along the north side of Twomile Canyon.

7.1.4.5 Cerro Grande Ash

Various inorganic chemicals and radionuclides are elevated above BVs in ash from the Cerro Grande burn area, and downcanyon transport of ash in post-fire floods has affected the chemistry of sediment deposits in many canyons in and near the Laboratory (Katzman et al. 2001, 072660; Kraig et al. 2002, 085536; LANL 2004, 087390). As discussed in previous sections, the occurrence of several COPCs in the Pajarito watershed is dominated by the redistribution of ash, and some COPCs show a combination of sources, including both releases from Laboratory sites and redistribution of Cerro Grande ash. Manganese, cesium-137, and plutonium-239,240 are COPCs whose distribution in the Pajarito watershed is dominated by the redistribution of ash (Sections 7.1.1 and 7.1.3; Figures 7.1-1 and 7.1-8). Barium, cyanide, and TCDD are COPCs whose distribution indicates a combination of Laboratory releases and redistribution of ash (Sections 7.1.1 and 7.1.2; Figures 7.1-1 and 7.1-6). Post-fire floods were effective at transporting ash the full length of the Pajarito watershed from the Santa Fe National Forest west of NM 501 into lower Pajarito Canyon below White Rock, particularly in summer 2000, before the Pajarito Canyon FRS was constructed a short distance below the Pajarito–Twomile Canyon confluence. Most of the erosion of ash from the Cerro Grande burn area occurred in 2000 (Reneau et al. 2007, 102886), and sediment deposits from 2001 and later would have lower concentrations of ash and associated COPCs. The largest post-fire flood in the Pajarito watershed before FRS construction occurred on June 28, 2000, with an estimated peak discharge of 1020 cubic feet per second (cfs) at gaging station E240 west of NM 501 and 14 cfs at E250 near the eastern Laboratory boundary (Shaull et al. 2001, 072609.112, pp. 36, 47). This flood left sediment deposits dominated by ash (“muck”) in the reach PA-4 wetland and other areas where peak discharge was decreasing as the flood attenuated and also in other parts of the watershed.

7.1.4.6 Natural Background Variability

Sediment data from different canyons indicate that natural background concentrations for many inorganic chemicals and radionuclides are more variable than found in the original sediment background data set used to develop BVs for the Laboratory (LANL 1998, 059730; McDonald et al. 2003, 076084). As a result, sediment concentrations can be elevated above BVs even where there are no Laboratory releases. For example, in Cañada del Buey above White Rock, a short distance northeast of Pajarito Canyon reach PA-4, sampling of sediment in local drainages not affected by Laboratory operations identified a series of inorganic chemicals as being elevated above BVs in that area (barium, cobalt, iron, selenium, and vanadium; Drakos et al. 2000, 068739). Similarly, the spatial distribution of COPCs in the Pajarito watershed indicates that the concentrations of several inorganic chemicals and radionuclides largely or

entirely record natural background variations and not Laboratory releases, including aluminum, antimony, iron, perchlorate, selenium, thorium-228, and thorium-232 (Sections 7.1.1 and 7.1.3). The sediment data indicate that the distribution of other COPCs record a combination of Laboratory releases and natural background variations (e.g., arsenic and vanadium) or a combination of redistribution of Cerro Grande ash and natural background variations (e.g., manganese). The distribution of one organic COPC, benzoic acid, also indicates a primary source in natural background or false positives from the analytical laboratory. (Note: Because no background study has been conducted at the Laboratory for organic chemicals, their natural concentrations are not defined.)

7.1.5 Temporal Changes in Contaminant Concentration

In comparison to other watersheds at the Laboratory (e.g., the watersheds of Los Alamos, Pueblo, and Mortandad Canyons; Malmon 2002, 076038; LANL 2004, 087390; Reneau et al. 2004, 093174; Malmon et al. 2005, 093540; LANL 2006, 094161), changes in contaminant concentrations in sediment in the Pajarito watershed over time are not well defined for several reasons. These reasons include the more limited long-term monitoring that has occurred in the Pajarito watershed and the lack of documentation of temporal changes in contaminant releases. In general, it is expected that contaminant concentrations will be highest in sediment deposited near the time of peak contaminant releases and progressively decrease over time associated with mixing. However, sediment data from the Pajarito watershed indicate some exceptions to these trends, as discussed previously. Specifically, for some contaminants (e.g., cadmium, chromium, and copper), average concentrations in some downcanyon reaches that removed the sources are higher in post-fire sediment deposits than in pre-fire deposits (Figures 7.1-11, 7.1-12, and 7.1-13). This increase over time probably results from larger floods and farther downcanyon transport after the Cerro Grande fire than before 2000. The spatial distribution of these COPCs indicates that before the fire, there was little transport past TA-18 and the confluence of Pajarito and Threemile Canyons associated with generally smaller and less frequent floods. The large wetlands in borrow pits east of TA-18 also helped to attenuate floods and restrict downcanyon transport. In contrast, post-fire floods were effective at both eroding post-1942 sediment deposits near the sources that contained elevated levels of these COPCs and transporting some of this sediment through the wetlands and White Rock.

Information on recent trends in the concentrations of some COPCs transported by floods in the Pajarito watershed are provided by samples collected near the Pajarito-Twomile Canyon confluence in the area where water has been impounded behind the FRS (reaches PA-2W and TW-4E). The two largest floods that occurred here after construction of the FRS were on August 24, 2005, and August 25, 2006, and sediment deposited in these events was sampled in PA-2W and TW-4E to document concentrations of COPCs being transported from upper Pajarito Canyon and Twomile Canyon in large events.

Figure 7.1-18 compares average concentrations of cadmium, chromium, and copper in fine facies samples from PA-2W deposited before the Cerro Grande fire (1943–1999) after the fire but before 2005 (2000–2004) and in the August 2005 and 2006 events. There is no consistent pattern in these data. Average concentrations of cadmium in 2000–2004 are slightly lower than before the fire, but for chromium and copper they are higher. For all three metals, average concentrations in 2005–2006 are similar to pre-fire concentrations.

Figure 7.1-19 compares average concentrations of Aroclor-1260 and benzo(a)pyrene in fine facies samples from TW-4E deposited in the August 2005 and 2006 events with pre-fire and 2000–2004 sediment from reach TW-4W, the next sampled upcanyon reach. For Aroclor-1260, concentrations in 2005–2006 are similar to or slightly less than before the fire; Aroclor-1260 was not detected in the single post-fire sample from TW-4W. In contrast, benzo(a)pyrene concentrations are highest in 2005–2006 sediment and least in pre-fire sediment, indicating that concentrations are increasing over time. This

apparent increase in benzo(a)pyrene concentration is consistent with increasing development in the Twomile watershed over time and a continued source in runoff from developed areas.

7.2 Conceptual Model for Hydrology and contaminant transport in water

This section summarizes the main elements of the conceptual model for hydrology and contaminant transport in water for the Pajarito watershed, including tributary canyons. The conceptual model is largely based on data and interpretation presented in the "Pajarito Canyon Work Plan" (LANL 1998, 059577) and on new information collected to satisfy work plan and other groundwater-investigation requirements and presented in the appendixes of this report. The primary focuses of this section are to summarize the hydrologic conceptual model (Section 7.2.1) and to discuss the observed distributions of contaminants within the watershed (Section 7.2.2). Figure 7.2-1 illustrates key aspects of the hydrologic conceptual model for the watershed, including contaminant pathways. The conceptual model forms the basis for identifying hydrologic pathways for contaminants to move from surface sources into surface and subsurface water. New hydrologic and contaminant trend data that support this updated conceptual model include: analyses of transient surface water flows and alluvial and regional water levels (Appendixes L and I), vadose zone profiles of water content and contaminant distributions with depth (Appendix H), contaminant distributions in surface water, storm water, alluvial groundwater, perched-intermediate water and the regional aquifer (Appendixes D and F), hydrologic and geochemical characteristics of the springs (Appendix K), observations at new alluvial monitoring wells (Appendix G), analyses of a spinner log run at production well PM-2 (Appendix J), interpretation of resistivity surveys (Appendix N), and a groundwater monitoring well network analysis (Appendix M).

7.2.1 Hydrologic Conceptual Model

7.2.1.1 Surface Water

Sources of surface water in the Pajarito watershed currently include snowmelt, stormwater runoff and discharges at several springs (Appendixes K and L). Perennial surface flow occurs at three locations in the watershed (Plate 1 and Figure 7.2-1). Farther west, a perennial reach created by PC Spring extends to approximately the Pajarito Fault zone. There is evidence that some of the surface water is lost to the Pajarito Fault zone and reemerges as spring flow farther down the watershed (Appendixes K and L, Figure 7.2-1). Homestead Spring supports another perennial reach for approximately a mile, with contributions from several springs located in tributary canyons adding to the flow (Appendix L). The third perennial reach occurs approximately 0.6 km (0.4 mi) upstream from the confluence with the Rio Grande, where the 4-Series springs form a short segment of stream flow to the confluence with the Rio Grande (Appendix K). Between these perennial reaches, stream flow is ephemeral and/or intermittent. Springs in Twomile and Threemile Canyons also contribute to intermittent stream flow in the watershed.

Data presented in Appendix L show that stream flow rates and stream losses are highly variable in the watershed, both by location and in time. The 2006 through early 2008 data indicate that both net losses and net gains of surface flow can occur in the watershed west of gage E245 (Plate 1). This behavior very likely depends on antecedent conditions and precipitation. The western portion of the canyon is generally steep and narrow with a bedrock (tuff) floor and only thin, sparse alluvial deposits. In other canyons on the Pajarito Plateau (e.g., Sandia, Mortandad, and Los Alamos Canyons), these same conditions generally inhibit infiltration in favor of downcanyon stream flow. Downcanyon surface-water flow is also expected to dominate in the upper portion of the Pajarito watershed and is shown as minor infiltration in Figure 7.2-1 west of gage E245. East of gage E245, there is a net loss of surface water into underlying alluvium (Figure 7.2-1). Surface-water losses to canyon bottom alluvium are important in other canyons

across the plateau, and the conceptual model figure (Figure 7.2-1) reflects this behavior with a greater density of infiltration arrows in the eastern portion of the watershed.

There are currently no active outfalls that discharge effluent to the watershed. However, the "Work Plan for Pajarito Canyon" reports that historically 28 outfalls did release to the watershed (Table 2.2.1-2, LANL 1998, 059577) at volumetric flow rates of 16 gpm or less, with most reported as being intermittent releases with flows of less than 2 gpm. The various outfalls released cooling tower blowdown, photowaste discharge, HE wastewater discharge, and treated sanitary wastewater, which may have contributed contaminants to the watershed. Runoff from adjacent mesa-top SWMUs and AOCs may also transport contaminants into the canyons.

7.2.1.2 Alluvial Groundwater

The shallow alluvial groundwater body in Pajarito Canyon extends from below the confluence with Twomile Canyon to approximately regional well R-23, a distance of 7 km. The alluvial groundwater is recharged by stream flow, as described above, and some local precipitation. It accumulates in the alluvial deposits that fill the canyon bottom, often perching on shallow bedrock units. The alluvial groundwater extends farther downcanyon than does stream flow (Figure 7.2-1) because some downcanyon, lateral flow within the alluvium occurs. Alluvial groundwater acts as a source of infiltrating water into the deeper tuff units and into the Cerros del Rio basalt, which is very near the surface at well R-23. The extent of this groundwater helps define deeper infiltration zones within the canyon. Alluvial groundwater is probably lost to bedrock units beneath the canyon floor as indicated by several lines of evidence: (1) the persistent alluvial water present at well 18-BG-1 and east to approximately well PCO-3 in Pajarito Canyon (Appendix L), (2) relatively high moisture contents measured in vadose zone core collected during drilling of regional wells R-17, R-20 and R-32 and nitrate in the vadose zone porewater collected at well R-20 (Appendix H), and (3) the indication of low electrical resistivity (potentially indicating wet conditions) near the base of the alluvium and into underlying bedrock near the wetlands located by wells R-20 and R-23 (Appendix N).

Similar conditions (perched groundwater at an alluvium/tuff contact) exist in Mortandad and Sandia Canyons, and high, net-infiltration rates into the underlying tuff are estimated for portions of those canyons. However, there are distinct differences between Pajarito Canyon and these two canyons. For example, in Mortandad and Sandia Canyons, the alluvium lies atop the Cerro Toledo interval or Otowi Member tuff (Qbo) where infiltration rates are estimated to be highest. In contrast, beneath the alluvium in middle and lower Pajarito Canyon, the predominant bedrock is Tshirege unit Qbt 1g with Cerros del Rio basalt dominating east of well R-23. Alluvial water is present over a much greater distance in Pajarito Canyon (7 km, from confluence with Twomile Canyon to well R-23) than in Mortandad (1.6 km to well MCOBT-8.5) and Sandia (1.8 km to well R-11) Canyons. The difference in bedrock geology may account for the greater extent of alluvial groundwater in Pajarito Canyon than is present in the other two canyons. Where unit Qbt 1g is present beneath the alluvium (e.g., at wells PCO-1 and PCO-2), water levels are nearly constant and are close to the ground surface, wetlands (within former borrow pits) are present, and the alluvial groundwater body is relatively wide. These conditions indicate that deeper recharge to the tuff unit may be quite slow and that groundwater can be lost to evapotranspiration. In contrast, rapid decline of alluvial groundwater levels at well PCO-3 (Figure 7.2-1) following periods of low stream flow implies that the alluvial groundwater system may drain quickly into the basalt at this location near the terminus of alluvial groundwater (Appendix L). The resistivity survey also indicates that there are highly conductive zones near R-23 where the basalt is close to the surface (Appendix N). These observations lead to the depiction of infiltration occurring near wells R-20 and R-23 (Figure 7.2-1). Overall, lateral flow within the alluvium and deeper infiltration of alluvial groundwater into underlying bedrock may provide a driving force

for subsurface transport of soluble contaminants along the length of the canyon and into the deeper subsurface.

7.2.1.3 Vadose-Zone Hydrology

Infiltration of surface water and alluvial groundwater to bedrock units may result in the predominantly vertical transport of mobile contaminants. Movement of moisture and contaminants probably occurs as gravity (predominantly vertical) and moisture-gradient-driven (occurring in all directions) porous flow. Infiltration patterns are likely to be spatially nonuniform and transient based on the transient nature of stream flow and alluvial groundwater levels observed in the canyon (Appendix L). Between Twomile Canyon and stream gage E250, unit Qbt 1g underlies the alluvium in much of the canyon floor. Ranges in spatially average infiltration rates for middle and lower Pajarito Canyon estimated using two techniques are 15 to 900 mm/yr and 100 to 750 mm/yr (Appendix L). Infiltration patterns may be quite steady (temporally) where unit Qbt 1g is present (Figure 7.2-1) because alluvial groundwater levels there are near constant (Appendix L), although preferential flow paths may be present and still yield steady water levels. Infiltration near wells R-23 and PCO-3 is likely to be more transient and may be more focused and quite rapid through the fractured basalt, as indicated by water levels measured at well PCO-3 (Appendix L).

In other canyons, infiltration rates are observed to be higher where the canyon floor flattens out and the alluvium thickens, than in steeper upgradient sections. This is true, for example, in Mortandad Canyon below the Ten-Site Canyon confluence (LANL 2006, 094161). This behavior is likely to occur in Pajarito Canyon as well, with higher infiltration rates expected to occur in the lower canyon below TA-18 than upstream of TA-18 in the middle canyon, although there are currently little data to support this assumption. This hypothesis is illustrated in Figure 7.2-1, where the density of infiltration arrows describes the magnitude of the expected infiltration rates. There is a single infiltration arrow around well 18-BG-1, where the canyon floor is relatively steep, and little alluvial fill and alluvial groundwater exist. Conversely, near TA-18, the figure shows a higher density of infiltration arrows. In addition, higher infiltration rates are observed at canyon confluences in other canyons, such as at the DP Canyon/Los Alamos Canyon confluence (LANL 2008, 101330). Potentially, enhanced infiltration in the subsurface may occur at the three confluences where the south fork of Pajarito Canyon, Twomile Canyon and Threemile Canyon intersect Pajarito Canyon.

7.2.1.4 Perched Intermediate Groundwater

Perched intermediate groundwater occurs in a variety of settings beneath the Pajarito watershed. Occurrences are known from deep groundwater investigations and from more localized SWMU investigations. The location and nature of these occurrences are consistent with and indicative of known or suspected canyon reaches with higher infiltration and the existence of underlying perching horizons. There is no indication that the perched intermediate zones are laterally continuous over large areas. Ongoing groundwater investigations underway as of this writing will help refine the understanding of perched-intermediate water in the vicinity of TA-54

Well R-17: At well R-17 a video log collected when the borehole was at 269.7-m (885-ft) depth showed perched intermediate water emerging in an interval from 150.9- to 154.2 -m (495- to 506-ft) depth and from a more discrete interval at 157.9-m (518-ft) depth, within the upper Puye Formation, as well as at 178.0-m (584-ft) depth in the upper section of underlying Tschicomma dacitic lavas. Later video logs showed water entering the borehole from lower in the dacitic lavas at 204 m (670 ft) and from Puye Formation below the dacites at 256 m (840 ft), but the small flows may be attributable to water introduced during drilling. Two screening groundwater samples were collected with bailers from standing water in the

open borehole at depths of 259.1 m (850 ft) and 261.2 m (857 ft), both of which represent water that had drained into the open borehole from this perched zone. A groundwater- screening sample collected from borehole R-17 contained EZ-MUD and QUIK-FOAM and elevated concentrations of sodium (69.53 mg/L) and sulfate (30.2 mg/L). High explosive compounds were not detected above an MDL of 0.01 ppm in the borehole sample. Detection of potential contaminants is limited because of the presence of drilling fluids in the borehole-screening sample collected from the perched zone. No well was installed in this perched zone.

Well R-23i: Well R-23i specifically targeted a perched interval indicated at approximately 128.0-m (420-ft) to 170.7-m (560-ft) depth that was encountered during prior drilling of regional aquifer well at R-23. At well R-23i, perched intermediate groundwater was encountered in Cerros del Rio basalt when standing water was first measured at 138.4-m (454.2-ft) depth in the open borehole with a bottom depth of 170.7 m (560 ft). Video logs were run to identify perched water zones and water was observed to be seeping in at approximately 123.0-m (403.5-ft) and 132.9-m (436-ft) depth. Depth to water was measured at 137.1 m (449.8 ft) after video logging. Video logs could not be obtained below approximately 145.1-m (476-ft) depth due to a bridge that formed in the open borehole, so water-bearing zones below that depth could not be observed. Based on the video logs, geophysical logs, and cuttings, two screens were placed in an 11.4-cm (4.5-in.) stainless-steel well, one screen at 143.3–146.3 m (470.2–480.1 ft) targeting an interflow zone at 143–146- m (470–480-ft) depth between Cerros del Rio lavas, and a deeper screen at 159.7–166.7 m (524.0–547.0 ft) targeting a second interflow zone with sandy sediment extending from a depth of 160–168 m (525–550 ft). Following well installation, the depth to water was 136.9 m (449.1 ft) without a packer between the middle and bottom screens. With a packer between the screened intervals, the depth to water for the bottom screen was 138.4 m (454.0 ft) and for the middle screen it was 137.1 m (449.8 ft). A third screen was emplaced in a 5.1-cm (2-in.) stainless-steel well in the primary borehole annulus at 122.0–128.0-m (400.3–420.0-ft) depth to capture the top of perched saturation as indicated by resistivity logging. The depth to water in the 5.1-cm (2-in.) well following construction was 123.7 m (405.9 ft).

Water levels measured in R-23i screens 2 and 3 show a slow constant decline from early 2006 to April 2008 of about 2 ft (Appendix L). However, water levels have increased since April 2008 (Appendix L) and may be associated with snowmelt runoff measured in lower Pajarito Canyon at stream gage E250 (Figure 7.2-1).

SM-30: Shallow perched water occurs in wells installed as part of investigation of subsurface contamination associated with SWMU 3-010(a) behind building SM-30. The occurrence of this perched water appears to be spatially limited and exists within fill material and in the upper portion of unit Qbt 4 of the Tshirege Member of the Bandelier Tuff. More information on the nature of this perched water is provided in LANL (LANL 2003, 081599).

7.2.1.5 Regional Aquifer Hydrology

Similarly to the conditions observed to the north of Pajarito Canyon, the regional aquifer can be represented as a complex heterogeneous system that includes confined and unconfined zones. The degree of hydraulic communication between these zones is thought to be spatially variable. The shallow portion of the regional aquifer (near the water table) is predominantly under phreatic (unconfined) conditions and has limited thickness (approximately 30 to 50 m [98 to 164 ft]). Groundwater flow and contaminant transport directions in this zone generally follow the gradient of the regional water table; the flow is generally northeastward beneath the eastern section of Pajarito watershed southeastward beneath the western section of Pajarito watershed (Figure M-1). The ambient regional groundwater flow gradients are relatively high to the east (close to the Pajarito Fault zone) and to the west (close to the Rio Grande), varying between 0.003 and 0.01 m/m. Because of relatively low rates, the infiltration recharge along

Pajarito watershed is not expected to affect the shape of regional water table. The preliminary water-level data from R-37 indicate that the applied water-table map may need to be updated. The new water-level data from R-37 and other new regional monitoring wells should be applied to update the regional water-table map and characterize better the flow directions in the regional aquifer.

The deep portion of the regional aquifer is predominantly under confined conditions, and it is stressed by Pajarito Plateau water-supply pumping. The intensive pumping causes small water-level fluctuations in the phreatic zone. The largest seasonal fluctuations are observed at R-20 screen 1: 0.2 m (0.6 ft) (see Appendix L). R-20 is located 0.25 mi east-southeast of PM-2. These low-magnitude responses in the phreatic zone from municipal well pumping are in sharp contrast to the larger responses at monitoring wells completed in deeper parts of the aquifer (e.g., R-20 screen #3), indicating that the hydraulic communication between the phreatic zone and deeper parts of the aquifer is poor. The small scale fluctuations in the phreatic zone may be from drawdowns and/or strata compaction (Appendix I). However, the water-level fluctuations do not seem to affect the magnitudes and directions of groundwater flow. Capture of contaminants by supply well PM-2, which is screened approximately 1004 to 2280 ft bgs (or 160 to 1440 ft below the regional water table), is probably unlikely because of this poor vertical hydraulic communication. The vertical stratification of the regional aquifer is also demonstrated by the PM-2 spinner test (Appendix J). As a result, it can be expected that contaminant migration follows the ambient water-table gradients rather than diverting toward the pumping water-supply wells based on hydraulic data.

Poor hydraulic communication does not preclude the possibility that some contaminant migration may occur between the shallow and deep zones. Between the two zones, the hydraulic gradient has a strong downward vertical component because of water-supply pumping, creating the possibility that downward contaminant flow may occur along "hydraulic windows," although these have not been directly observed.

The numerical model applied for evaluation of the monitoring-network efficiency (Appendix M) assumes that the capture zone of the water-supply wells partially extends to the regional water table (along vertical hydraulic windows). This causes some of the potential contaminants originating along Pajarito Canyon to be detected at PM-2, PM-4 and PM-5. Future analyses of the capture zone of the water-supply wells near Pajarito Canyon are expected to constrain this conceptual uncertainty. These analyses will utilize the spinner test that was recently performed at PM-2 (Appendix K) and the new hydrogeologic information collected at R-40 and other new regional monitoring wells close by.

7.2.2 COPCs in Water

A variety of contaminants are identified as COPCs in surface water and groundwater within and beneath the watershed (see Section 6). Appendix D provides box plots (Figures D-2.1-1 through D-2.1-10) and time series plots (Figures D-2.2-1 through D-2.2-207) for a variety of metals (barium, boron, iron, mercury, and uranium), anions (chloride, nitrate plus nitrite, and perchlorate), radionuclides (tritium and uranium-234), and organic compounds (1,4-dioxane; 1,1-dichloroethene; and 1,1,1-trichloroethane). Most of these have been identified infrequently or at trace concentrations. The discussion presented in Section 7 focuses on the most mobile constituents as a means of identifying surface water and groundwater pathways. Nitrate, perchlorate, and tritium are the most mobile of the contaminants historically released in the watershed. These constituents have been measured at concentrations above background in surface water and in alluvial, perched intermediate and/or regional groundwaters. Their presence has also been observed in vadose-zone pore water collected from core samples from three boreholes drilled in Pajarito Canyon (Appendix H). Localized contamination of RDX; 1,4-dioxane; and/or VOCs occurs at several intermediate-depth wells and springs and one regional aquifer well. These combined results provide a comprehensive picture of subsurface contaminant distributions and migration at various locations in the Pajarito watershed. Analytical results for tritium, nitrate, and perchlorate in

particular are useful because of the high mobility of these contaminants in the subsurface (i.e., they move at similar rates to subsurface pore water). Thus, their distribution is likely to bound the subsurface extent of other nonadsorbing contaminants that have followed the same migration pathway.

7.2.2.1 Inorganic Chemicals in Water

Several inorganic chemicals are identified in Section 6 as being COPCs in water. The sections below discuss the spatial distribution and subsurface migration of these COPCs.

Nitrate

Nitrate is detected in surface water, alluvial and perched intermediate groundwater and the regional aquifer beneath Pajarito Canyon. There are both natural and anthropogenic sources of nitrate within the watershed, with Laboratory-derived nitrate from treated sewage effluent at TA-09 and TA-18 as the dominant sources. Nitrate concentrations in treated sewage effluent are typically less than 3 mg/L because of denitrification. Concentrations of nitrate and nitrate plus nitrite in groundwater beneath the Pajarito watershed are less than 10 mg/L as N, the NMWQCC groundwater standard. Natural nitrate is common on the Pajarito Plateau and in the American Southwest (Walvoord et al. 2003, 093787). Thus, detection of low concentrations of nitrate (<0.5 mg/L as nitrogen) does not mean that contamination is present. However, it is clear that for several locations in the Pajarito watershed discussed below, the nitrate concentrations are elevated and related to historical Laboratory releases.

Under oxidizing conditions, nitrate is mobile as an oxyanion in groundwater and does not significantly adsorb onto clay minerals, ferric (oxy)hydroxide, solid organic matter, and other naturally occurring adsorbents. In the presence of denitrifying bacteria and reactive solid and dissolved organic carbon, nitrate becomes reduced to nitrogen gas. Other types of nitrate-reducing bacteria are capable of reducing nitrate to ammonium under oxygen-depleted conditions below pH 9. In the discussion that follows, nitrate concentrations are based on different sampling and analysis techniques to obtain the largest data sets. Results for nitrate and nitrate plus nitrite are combined because nitrite is generally a very small part of the measured concentration. Filtered and nonfiltered results are also combined because filtration has little to no effect on nitrate concentration. Nitrate concentrations in the discussions that follow are reported in the units "Nitrate (as N, mg/L)," unless otherwise noted.

Nitrate in Surface Water and Alluvial Groundwater

The spatial trends in recent (2000–2008) nitrate plus nitrite concentrations in surface water and alluvial groundwater are shown in box plots (Appendix D, Figure D-2.1-6) and in numerous time series plots (Appendix D) for samples collected in upper Pajarito Canyon, in upper Twomile Canyon, in upper Threemile Canyon, and in Pajarito Canyon at and east of TA-18. Above the TA-18 facilities, the nitrate plus nitrite concentrations are low (<0.2 mg/L). Nitrate plus nitrite concentrations in alluvial groundwater slightly increase in Pajarito Canyon near the TA-18 facilities and below the remediated TA-18 sewage lagoons (SWMU 18-001(a), indicating that these structures and former sewage lagoons provide a source of nitrate to the watershed. Concentrations of nitrate plus nitrite range from 0.525 to 6.0 mg/L at well 18-MW-9 (Figure D-2.2-15) and from 0.179 to 3.18 mg/L at 18-MW-11 (Figure D-2.2-21). Nitrate plus nitrite concentrations range from 0.575 to 1.54 mg/L at well 18-MW-18 (Figure D-2.2-27) located downgradient of the sewage lagoons. Figure D-2.2-39 (well PCO-1), D-2.2- 45 (well PCO-2), and D-2.2-51 (well PCO-3) is a time series plot for alluvial wells in Pajarito Canyon covering the period from 1985 to 2008. Concentrations of nitrate plus nitrite decrease farther downcanyon at wells PCO-2 and PCO-3 in response to dilution and/or partial denitrification occurring within organic-rich wetlands.

Nitrate in Vadose-Zone Pore Water and Perched Intermediate Groundwater

Nitrate has migrated from surface water and alluvial groundwater into the deeper vadose zone, probably since effluent releases began in the Pajarito watershed at TA-09 and TA-18 commencing in 1943. Depth profiles of pore-water nitrate concentrations in three core holes (R-17, R-20, and R-32) may reflect localized releases to the watershed (most notably at core hole R-20) (see Figure H-1.0). Nitrate was detected in the three core holes analyzed, and vadose-zone pore-water concentrations are as high as exceed 30 mg/L.

Dissolved concentrations of nitrate at core hole R-17 are generally less than 2 mg/L and probably are derived from natural sources because of the uniform pore-water concentrations with depth. These data indicate that the elevated concentrations of nitrate discharged at the TA-09 springs, discussed below, did not persist at elevated concentrations as surface water and alluvial groundwater as far east as well R-17. Evidently, infiltration near well R-17 was characterized by low nitrate concentrations or very low infiltration rates.

Core samples from well R-20 contain elevated nitrate concentrations between 3 and 46 m (10 and 150 ft). The cores were collected within the vadose zone from the Tshirege Member. Surface and alluvial groundwater analytical results discussed above indicate TA-18 is the likely source of the nitrate found in the R-20 core samples. The elevated pore-water nitrate concentrations in core indicate R-20 is located in a zone of infiltration. This interpretation is supported by the elevated water content of the Tshirege tuffs at R-20 and the occurrence of persistent alluvial groundwater in the vicinity of this well. The localized zone of well-defined contaminant extent is consistent with the general conceptual model of transport depicted in Figure 7.2-1.

Elevated nitrate plus nitrite concentrations are reported at several of the TA-09 springs (Anderson, Bulldog, Kieling, and Starmer) discharging from the Tshirege Member within upper reaches of the Pajarito watershed (Figures D-2.2-120, D-2.2-126, D-2.2-144, and D-2.2-186). Reliable concentrations of nitrate plus nitrite range from 0.20 to 1.11 mg/L in samples collected from the TA-09 springs. Concentrations of nitrate plus nitrite at 600 mg/L or greater in several groundwater samples, for example, Bulldog Spring and PC Spring, are not considered reliable because they were probably preserved with nitric acid. The presence of nitrate contamination at the TA-09 springs indicates that there are local zones of infiltration in the vicinity of Laboratory release sites that contribute recharge to native perched groundwater that occurs in the Bandelier Tuff (Appendix K).

Detected concentrations of nitrate plus nitrite range from 0.403 to 0.970 mg/L at well R-23i (Figure D-2.2-78) completed within the Cerros del Rio basalt. Several samples collected from screens 2 and 3 contain nitrate plus nitrite at concentrations ranging from 0.403 to 0.970 mg/L and 0.70 to 2.93 mg/L, respectively. This well is east of the release sites at TA-09 and TA-18, and the presence of anthropogenic nitrate plus nitrite at this well may result from sources within the Pajarito watershed. Releases of nitrate plus nitrite from Los Alamos and Sandia Canyons may also contribute to the elevated concentrations of this contaminant at well R-23i, provided that groundwater flow within perched intermediate zones continues south of Sandia Canyon.

Nitrate in the Regional Aquifer

Background mean and median concentrations and the BV (UTL) for dissolved nitrate plus nitrite are 0.33, 0.31, and 0.89 mg/L, respectively, within the regional aquifer (LANL 2007, 095817). Concentrations of nitrate plus nitrite range from 0.14 to 0.41 mg/L at well R-17 (Figure D-2.2-84) from 2007 to mid-2008, which are reflective of background conditions at the well. Concentrations of dissolved nitrate were at background levels, ranging between 0.22 and 0.33 mg/L, during well rehabilitation of well R-32 screen 1

conducted in late November 2007. Groundwater samples collected from well R-18 (Figure D-2.2-90) have concentrations of nitrate plus nitrite that generally increased from 0.39 to 0.69 mg/L from 2005 to mid-2008. These concentrations do not exceed the BV for the regional aquifer. Anthropogenic nitrate has been detected in the regional aquifer beneath Pajarito Canyon east of TA-18. Dissolved concentrations of nitrate ranged from 0.97 and 1.03 mg/L during well rehabilitation of well R-32 screen 1 (Figure D-2.2-114) conducted in mid-October 2007. Nitrate plus nitrite concentrations in filtered samples collected from well R-23 generally increased from 0.52 to 1.95 mg/L during the 2003 to 2008 sampling period, as shown in Figure D-2.2-108.

The 4-series springs in White Rock Canyon, including Springs 4, 4A, 4AA, 4B, and 4C, represent discharge zones for groundwater within lower reaches of the Pajarito watershed (Appendix K). Springs 4A and 4AA represent discharge from the regional aquifer based on major cation and anion compositions, ages (tritium/helium-3 and carbon-14), and temperatures. Springs 4, 4B, and 4C appear to be more closely related to intermediate groundwater but may represent mixtures of surface (meteoric), perched, and regional groundwater. Dissolved concentrations of nitrate plus nitrite range from 0.28 to 1.66 mg/L at the springs (Spring 4, 1.22 to 1.66 mg/L; Spring 4A, 0.8 to 1.6 mg/L; Spring 4AA, 0.92 to 1.66 mg/L; Spring 4B, 0.28 to 0.91 mg/L; and Spring 4C, 1.27 to 1.62 mg/L). Figures D-2.2-156, D-2.2-162, D-2.2-168, D-2.2-174, and D-2.2-180 show nitrate and nitrate plus nitrite concentrations versus time at the 4-series springs. Most of the analytical results for nitrate plus nitrite are elevated above background concentrations for the regional aquifer. Results of nitrogen ($\delta^{15}\text{N}$) stable isotope analyses of the 4-series springs sampled in September 2005 range from +2.9 to +7.3 per mil (‰), including Spring 4 (+6.51‰), Spring 4A (7.33‰), Spring 4AA (7.29‰), and Spring 4C (2.9‰). These results indicate that variable groundwater mixing has taken place and that the source of nitrate possibly is from treated sewage effluent. Discharge of nitrate from industrial outfalls and septic tanks within the Pajarito watershed is considered to be a possible source of nitrate detected above background at the 4-series springs. Groundwater flow from Los Alamos, Sandia, and Mortandad Canyons to the 4 series springs is an alternative hypothesis based on the southern dip of flow units comprising the Cerros del Rio basalt.

Perchlorate

Natural and anthropogenic perchlorate is detected at low concentrations in surface water, alluvial and perched intermediate groundwater, and the regional aquifer beneath Pajarito Canyon (Dale et al. 2008, 102797). Perchlorate may have been discharged into Pajarito Canyon from TA-09 outfalls as early as 1943 (LANL 1998, 059577). The primary source of perchlorate is from perchloric acid (HClO_4), a strong oxidizing acid used in actinide and explosives research and processing at the Laboratory. Perchlorate is mobile and stable as an oxyanion in groundwater and does not significantly adsorb onto clay minerals, ferric (oxy)hydroxide, solid organic matter, nor other naturally occurring adsorbents. Filtered and nonfiltered results are combined in the discussions that follow because filtration has little to no effect on measured perchlorate concentration.

Perchlorate in Surface Water and Alluvial Groundwater

The spatial trends in recent (2001–2008) perchlorate concentrations in surface water and alluvial groundwater are shown in several box plots (Appendix D, Figure D-2.1-7) and in numerous time series plots (Appendix D) for samples collected in upper Pajarito Canyon, in upper Twomile Canyon, in upper Threemile Canyon, and in Pajarito Canyon at and east of TA-18. The perchlorate concentrations vary at the alluvial wells and surface-water stations but are generally less than 0.50 $\mu\text{g/L}$. Concentrations of perchlorate typically are less than 0.35 $\mu\text{g/L}$ at the surface-water stations in Pajarito Canyon below confluences with Twomile and Threemile Canyons. For this report, only those detected concentrations of perchlorate analyzed by liquid chromatography-mass spectrometry/mass spectrometry (EPA SW846

modified Method 6850) were used because this method provides a lower detection limit. Analytical results obtained from ion chromatography (EPA SW846 Method 314) for perchlorate were not considered due to higher method detection limits (MDLs) (1 to 3 µg/L), resulting in a large number of nondetects of perchlorate in water samples.

Appendix D contains several time series plots covering the period 2001 through early 2008 for perchlorate concentrations at several alluvial wells near and east of TA-18. Detected concentrations of perchlorate at monitoring well 18-BG-1 (Figure D-2.2-4) ranged from 0.29 to 0.38 µg/L, providing a baseline for concentrations of this trace anion from potential TA-18 releases. Concentrations of perchlorate ranged between 0.10 and 0.57 µg/L at the alluvial wells near and east of TA-18, which are slightly elevated over those measured at well 18-BG-1 and the surface-water stations within the watershed. Concentrations of perchlorate range from 0.25 to 0.57 µg/L at well 18-MW-9 (Figure D-2.2-16) and from 0.31 to 0.42 µg/L at well 18-MW-11 (Figure D-2.2-22).

Perchlorate in Vadose-Zone Pore Water and Perched Intermediate Groundwater

Perchlorate is present at low concentrations in the perched-intermediate springs in the upper watershed, but the specific source is not known. Possible sources include historical TA-09 effluent releases. Detected concentrations of perchlorate at the TA-09 springs range from 0.14 to 1.09 µg/L, including Anderson Spring (0.32 to 0.63 µg/L) (Figure D-2.2-121), Bulldog Spring (0.61 to 1.09 µg/L) (Figure D-2.2-126), Charlie's Spring (0.23 to 0.45 µg/L) (Figure D-2.2-133), Homestead Spring (0.14 to 0.41 µg/L) (Figure-D-2.2-139), Kieling Spring (0.38 to 0.86 µg/L) (Figure D-2.2-145), and Starmer Spring (0.15 to 0.46 µg/L) (Figure D-2.2-187). Concentrations of perchlorate decrease as TA-09 spring discharge water travels down Pajarito Canyon and mixes with alluvial groundwater. Detected concentrations of perchlorate range from 0.146 to 0.274 µg/L at R-23i (Figure D-2.2-79). One sample collected from screen 1 contains 0.177 µg/L of perchlorate and several samples collected from screens 2 and 3 contain perchlorate at concentrations ranging from 0.146 to 0.240 µg/L and 0.186 to 0.274 µg/L, respectively.

Perchlorate in the Regional Aquifer

Background mean and median concentrations and the BV (UTL) for dissolved perchlorate are 0.28, 0.29, and 0.46 µg/L, respectively, within the regional aquifer (LANL 2007, 095817). These results are consistent with a recent study by Dale et al. (2008, 102797). Perchlorate is below the BV at well R-17 (Figure D-2.2-85). Concentrations of perchlorate ranged from 0.22 to 0.27 µg/L at well R-18 (Figure-D-2.2-91), which are also within background levels. Concentrations of perchlorate at R-20 (Figure D-2.2-97) were 0.09 and 0.14 µg/L during June 2008, the first sampling round conducted after the 2007 well rehabilitation. Concentrations of perchlorate at well R-32 (Figure D-2.2-115) were 0.33 and 0.28 µg/L (March and June 2008) in two samples collected after the 2007 well rehabilitation and are less than the BV. The highest concentrations of perchlorate were measured at R-23, varying from 0.21 to 0.47 µg/L during 2003 to mid-2008 (Figure D-2.2-109). Measureable concentrations of perchlorate range from 0.21 to 0.40 µg/L at well R-22 (Figure D-2.2-103) from 2001 to mid-2008, in which several samples exceed mean and median concentrations and approach the UTL. Nondetection of perchlorate (<0.05 µg/L) in several samples collected from well R-22 (Figure D-2.2-103) most likely is related to residual drilling fluid effects in which perchlorate possibly has been reduced to chlorate, and chlorite, and/or hypochlorite.

Figures D-2.2-157, D-2.2-163, D-2.2-169, D-2.2-175, and D-2.2-181 show time-series plots for perchlorate concentrations (low-level method) at the 4-series springs. Concentrations of perchlorate range from 0.30 to 0.70 µg/L at the 4-series springs, including Spring 4, (0.60 to 0.65 µg/L), Spring 4A (0.46 to 0.53 µg/L), Spring 4AA (0.50 to 0.58 µg/L), Spring 4B (0.30 to 0.58 µg/L), and Spring 4C (0.61 to

0.70 µg/L). Most of the analytical results for perchlorate at these springs are consistently elevated above background concentrations (LANL 2007, 095817) for the regional aquifer. Discharge of perchlorate within the Pajarito watershed (TA-09) is considered to be a possible source. Other chemicals, including tritium and nitrate plus nitrite released in the Pajarito watershed and canyons to the north, are also detected above background at the 4-series springs.

Mercury within Alluvial and Perched Intermediate Groundwater and the Regional Aquifer

Mercury may be present at low concentrations in alluvial, perched-intermediate and regional groundwater throughout the watershed. The detections are infrequent and do not show any clear spatial trends that support an obvious point source. None of the values exceed the NMWQCC groundwater standard and the EPA drinking water standard of 0.002 mg/L for total mercury. Infrequent detection of mercury occur in filtered and nonfiltered samples collected from alluvial wells 18-MW-8 (0.12, 0.036, and 6.7 µg/L), 18-MW-9 (0.064 µg/L), and 18-MW-11 (0.12 and 0.63 µg/L). Mercury was not detected upgradient of TA-18 at well PCAO-5 during 2008 and is consistently below the detection limit at the TA-09 springs, except during one sample round conducted at Charlie's Spring (0.12 µg/L), and Homestead Spring (0.37 µg/L). Four samples collected from Kieling Spring, however, contained varying concentrations of mercury (ranging from 0.38 to 0.82 µg/L) in filtered and nonfiltered samples. Well R-23i completed within the Cerros del Rio basalt show infrequent detections of mercury in two samples (0.13 and 0.096 µg/L) collected in 2007 and 2008. Background mean and median concentrations for dissolved mercury are 0.03 and 0.03 µg/L (detection limit), respectively, within perched intermediate groundwater (LANL 2007, 095817).

Mercury is a contaminant that was identified in soil before remediation and residual concentrations are present in groundwater beneath SWMU 3-010(a), which was a former vacuum pump repair shop. Mercury was detected at well 03-B-9 at 0.034 µg/L (Figure D-2.2-55); at well 03-B-10, ranging from 0.059 to 1.7 µg/L (Figure D-2.2-62), and at well 03-B-13, ranging from 0.1 to 0.97 µg/L (Figure D-2.2-69).

Background mean and median concentrations for dissolved mercury are 0.04 and 0.03 µg/L (detection limit), respectively, within regional aquifer groundwater (LANL 2007, 095817). Mercury has not been detected in groundwater samples collected from regional aquifer wells R-17, R-18, and R-23. Two regional aquifer wells and one regional aquifer spring contain sporadic detections of mercury above background. Concentrations of mercury ranging between 0.13 and 0.29 µg/L have been measured in several groundwater samples collected from well R-20 during 2007 and 2008. Groundwater samples collected from well R-32 contain infrequent detects and low concentrations of mercury ranging from 0.051 to 0.53 µg/L during a sampling round conducted on June 24, 2005. Mercury has also been infrequently detected at Spring 4B (0.049 and 0.87 µg/L).

7.2.2.2 Organic Chemicals in Water

VOCs Petroleum Products and Total Organic Carbon

VOCs, including chlorinated solvents, used or potentially used at various TAs within the Pajarito watershed include 1,1-dichloroethane (1,1-DCA), 1,2-dichloroethane (1,2-DCA), *cis*-1,2-dichloroethene (*cis*-1,2-DCE), *trans*-1,2-dichloroethene (*trans*-1,2-DCE), 1,1,1-trichloroethane (1,1,1-TCA), trichloroethene (TCE), 1,1,2,2-tetrachloroethane (1,1,2,2-TCA), and 1,1,2,2-tetrachloroethene (PCE). The solvent 1,2-DCA was detected in alluvial groundwater at TA-18 with the source being a septic tank [SWMU 18-003(d)] (LANL 1996, 055120; LANL 1998, 059577). Groundwater contamination of 1,2-DCA was addressed at PRS-18-003(d) in the Corrective Action Report for TA-18 (LANL 1996, 055120). Five monitoring wells were drilled in the septic drain field area north of Casa 3 at PRS 18-003(d), according to

the voluntary corrective action plan (LANL 1996, 056554). Six additional monitoring wells (18-BG-1, 18-BG-4, 18-MW-8, 18-MW-9, 18-MW-11, and 18-MW-18) were drilled and sampled to define the nature and extent of 1,2-DCA-contamination within alluvial groundwater at TA-18. Concentrations of 1,2-DCA are less than analytical detection (1 µg/L) in samples collected from 18-BG-1, 18-BG-4, 18-MW-8, 18-MW-9, 18-MW-11, and 18-MW-18 from 2004 to mid-2008. An interim report summarizes the monitoring well installation and the initial results of two quarters of sampling (LANL 1997, 057015) without detecting 1,2-DCA and other VOCs. Monitoring of alluvial wells within the TA-18 area continues to date.

HE Compounds

RDX is one of the HE compounds produced and used in test experiments at TA-09 and was present prior to 1995 in treated effluent released to the environment probably since the early 1940s. This HE compound is soluble in aqueous solution and adsorption onto organic-poor sediment and aquifer material is minimal. The maximum practical quantitation limit (PQL) and MDL for RDX are 0.325 and 0.13 µg/L, respectively. RDX was detected at concentrations ranging from 1.06 to 6.42 µg/L in nonfiltered groundwater samples collected from Bulldog Spring from 2004 and 2008. This HE compound is also detected at Kieling Spring in several samples with concentrations ranging from 0.147 to 0.583 µg/L during the same period of sampling. Groundwater samples collected from the other TA-09 springs have concentrations of RDX less than analytical detection (0.13 µg/L).

Base-flow samples collected in Pajarito Canyon below the confluences of South and North Anchor East Basin contain concentrations of RDX ranging from 0.16 to 0.833 µg/L during 2007 and 2008. RDX is detected in base-flow samples at concentrations ranging from 0.171 to 0.201 µg/L collected above the confluence with Twomile Canyon.

RDX, octahydro-1,3,5,7-tetranitro-1,3,5,7-tetrazocine (HMX), 2,4,6-trinitrotoluene (TNT), and other HE compounds and associated degradation products have been detected in different alluvial wells (18-BG-1, 18-BG-2, 18-MW-1, 18-MW-2, 18-MW-3, 18-MW-4, PCO-1, PCO-2, and PCO-3) before 1998 at concentrations less than regulatory limits (LANL 1998, 059577). Since 1995, HE compounds have not been consistently detected at wells PCO-1, PCO-2, PCO-3, 18-BG-1, 18-MW-8, 18-MW-9, 18-MW-11, and 18-MW-18; they have not been detected in the newly installed alluvial wells PCAO-5, PCAO-6, PCAO-7a, PCAO-7b2, PCAO-7c, PCAO-8, and PCAO-9.

RDX was detected in regional well R-18 from 2006 to 2008 from 0.134 to 0.413 µg/L along with 2,6-diamino-4-nitrotoluene (2,6-DNT), a degradation product of TNT, at concentrations of 0.253 to 0.409 µg/L. Effluent discharges from TA-16 and possibly TA-09 are the most likely source(s) of RDX detected at well R-18. Groundwater samples collected from wells R-23i, R-17, R-20, R-23, and R-32 have not shown the presence of detected HE compounds and degradation products.

At well R-22, several HE compounds and degradation products, including 4,6-diamino-2-nitrotoluene (4,6-DNT) (0.07 µg/L), 2,6-dinitrotoluene (0.06 and 0.14 µg/L), 2,4-dinitrotoluene (0.03 and 0.04 µg/L), TNT (0.04 µg/L), 4-nitrotoluene (0.06 µg/L), tetryl (0.58 µg/L), nitrotoluene (0.0196 µg/L), and RDX (0.8 µg/L), were detected from open borehole samples conducted in 2000, and in subsequent samples collected from the well in 2002 and 2003. However, R-22 has been impacted from residual drilling fluid effects, and the occurrence of organic nitrogen functional groups (polyacryamide-polyacrylate) in EZ-MUD may have caused false positives for several of the HE compounds. Additional analyses using ultraviolet diode array spectroscopy detection failed to detect any HE compounds or degradation products in samples collected during 2001 and 2002 (Longmire 2002, 073676). Drilling of R-39 and R-41 near R-22 is anticipated to help resolve the presence or absence of HE compounds in the regional aquifer near R-22. HE compounds have not been detected in groundwater samples collected at the 4-series springs in White Rock Canyon.

1,4-Dioxane

Perched intermediate groundwater behind building TA-03-30 has recently shown detections of 1,4-dioxane at wells 03-B-9 (Figure D-2.2-59) (20.2 µg/L), 03-B-10 (Figure D-2.2-66) (ranging from 8.56 to 227 µg/L), and 03-B-13 (Figure D-2.2-73) (ranging from 21 to 746 µg/L). Other wells sampled in the Pajarito watershed, except for alluvial well PCO-3 (1190 µg/L, sampled on March 18, 2008), do not contain detected concentrations of 1,4-dioxane. Among other uses, this compound is used as a stabilizer for TCE and in other cleaning and detergent preparations all of which may have been used for SWMU 3 010(a).

Toluene, Acetone, and Bis(2-ethylhexyl)phthalate

Toluene has been detected at well R-20 in concentrations ranging from 0.263 to 112 µg/L in eight primary samples collected during 2006, 2007, and 2008. Concentrations of toluene range from 2.3 to 112 µg/L and 0.263 to 65.1 µg/L in screens 1 and 2, respectively. Several field trip blanks also contained toluene at concentrations ranging from 0.372 to 2 µg/L, in addition to two equipment blanks (6.29 and 15.8 µg/L). Most of the groundwater samples, however, have validated analytical results for this aromatic hydrocarbon. The source of toluene at well R-20 has not been resolved with any certainty. The NMWQCC groundwater standard for toluene is 0.75 mg/L (750 µg/L). Toluene is not considered to be a widespread COPC in surface water or groundwater within the Pajarito watershed.

Acetone has also been detected at well R-20 at concentrations ranging from 1.42 to 7570 µg/L in 26 samples collected from 2004 through mid-2008. Several field trip blanks also contained acetone at concentrations ranging from 1.25 to 7.9 µg/L, in addition to four equipment blanks (ranging from 4.42 to 9.2 µg/L). Most of the groundwater samples containing acetone are validated as detections without qualifiers. The source of acetone at well R-20 also has not been resolved with any certainty. Acetone is not considered to be a widespread COPC in surface water or groundwater within the Pajarito watershed.

Bis(2-ethylhexyl)phthalate was detected at a concentration of 6 µg/L in a nonfiltered sample collected from well R-32 (screen 1) on June 9, 2008. The EPA groundwater screening level is 4.8 µg/L for bis(2-ethylhexyl)phthalate. Detected concentrations of bis(2-ethylhexyl)-phthalate range from 3.92 to 6 µg/L at well R-32 (screen 1). Bis(2-ethylhexyl)phthalate is a component of plastics and could be derived from several sources, including analytical laboratory contamination, sample equipment, and possible Laboratory sources. The limited detection of this compound supports a source other than Laboratory sources. Further sampling will help determine if the compound persists.

7.2.2.3 Radionuclides in Water

Tritium is identified in Section 6 as being a COPC in surface water, alluvial and perched intermediate groundwater and/or the regional aquifer in the Pajarito watershed. A series of plots in Appendix D provides a high-level overview of the spatial trends of this COPC in the Pajarito watershed. The discussion below provides additional information on its spatial distribution in key areas of the watershed.

Tritium

Tritium is detected in surface water, alluvial groundwater, perched intermediate groundwater, and the regional aquifer in Pajarito Canyon. The background concentration of tritium in regional precipitation currently is 19 pCi/L (Longmire et al. 2007, 096660). Tritium is a radioactive isotope of hydrogen with a relatively short half-life of 12.32 yr, which decays to helium-3 with the emission of a beta particle (Clark and Fritz 1997, 059168). It is extremely mobile because it can replace hydrogen within a water molecule and travel as groundwater.

Tritium in Surface Water and Alluvial Groundwater

The spatial trends in recent (2006–2008) tritium concentrations in surface water and alluvial groundwater are shown in the box plots of Figure D-2.1-9. Several time series plots for tritium are provided in Appendix D. Concentrations or activities of tritium vary within surface water within Pajarito Canyon and may vary depending on the amount of precipitation the canyon received immediately before sampling. Concentrations of tritium ranged from 30 to 50 pCi/L in surface-water samples collected in Pajarito Canyon 0.8 km (0.5 mi) above SR 501 from 2006 to mid-2008. Tritium concentrations range from 23 to 65 pCi/L in upper Pajarito Canyon below the confluences of South and North Anchor East Basin, indicating that there may be a slight contribution of tritium in surface water from one or more sources in the upper watershed. Possible sources include spring discharges and atmospheric releases from the TA-16 tritium facility. Concentrations of tritium ranged from 43 to 70 pCi/L in surface water in Pajarito Canyon above the confluence with Twomile Canyon. The concentration of tritium was 53 pCi/L at alluvial well PCAO-5, located immediately downstream of the Twomile-Pajarito confluence.

Appendix D provides several time series plot covering the period from 2006 to early 2008 for tritium concentrations at several alluvial wells near and east of TA-18. Detected concentrations of tritium at monitoring wells 18-BG-1 (Figure D-2.2-5) ranged from 24 to 72 pCi/L, providing baseline concentrations of this isotope for comparison to potential TA-18 releases. Well 18-BG-4 upgradient of TA-18 contains 67.3 pCi/L tritium and downgradient wells 18-MW-18 (Figure D-2.2-29) and PCO-3 (Figure D-2.2-53) have tritium concentrations ranging from 46.5 to 93.5 pCi/L and from 60.02 to 88.4 pCi/L, respectively. In summary, concentrations of tritium ranged between 30 and 94 pCi/L at the alluvial wells near and east of TA-18, which are slightly elevated over those measured at well 18-BG-1 and the surface water stations within the watershed.

Tritium in Vadose-Zone Pore Water and Perched Intermediate Zones

Tritium has migrated from the surface water and alluvial groundwater into the vadose zone beneath Pajarito Canyon. Appendix H, Figure H-1.0, shows the distribution of tritium concentrations in core samples collected at the wells R-20 and R-32 core holes in the Pajarito watershed. These values are presented here as pore-water concentrations. Detected concentrations of tritium occur within the alluvium at the two core holes ranging from 25 to 2263 pCi/L. Tritium does not extend as deep as nitrate, which might be due to radioactive decay in the deepest (and oldest) vadose-zone pore water within the Bandelier Tuff. A more in-depth discussion of these core hole data is presented in Appendix H.

Tritium was detected in pore water collected from a core hole at R-17, ranging from 70,600 to 236,000 pCi/L (Figure H-1.0). Elevated gross beta activity from pore water analyzed from the same core samples appears to support the tritium observations. The significance and accuracy of the elevated tritium analytical results for R-17 cores remains uncertain, and additional work is proposed in Section 9 to resolve the question of whether significant tritium contamination is present in the vadose zone at this location.

Tritium is observed in perched intermediate groundwater, including the TA-09 springs and R-23i. Detected concentrations of tritium at the TA-09 springs ranged from 0.14 to 122 pCi/L, consisting of Anderson Spring (2.2 to 92 pCi/L) (Figure D-2.2-122), Bulldog Spring (35 to 98 pCi/L) (Figure D-2.2-128), Charlie's Spring (29 to 68 pCi/L) (Figure D-2.2-134), Homestead Spring (26 to 77 pCi/L) (Figure D-2.2-140), Kieling Spring (29 to 122 pCi/L) (Figure D-2.2-146), and Starmer Spring (26 to 74 pCi/L) (Figure D-2.2-188). Concentrations of detected tritium range from 21 to 177 pCi/L at well R-23i (Figure D-2.2-80) completed within the Cerros del Rio basalt. Fracture flow, coupled with groundwater mixing, may result in nonuniform concentrations of tritium within the different saturated zones comprising this complex hydrostratigraphic unit.

Monitoring wells 03-B-9, 03-B-10, and 03-B-13 located at building TA-03-30 contain elevated concentrations of tritium ranging from 191 to 2040 pCi/L within perched intermediate depth groundwater. Concentrations of tritium were 232 and 645 pCi/L at well 03-B-9 (Figure D-2.2-61), ranged from 191 to 749 pCi/L at well 03-B-10 (Figure D-2.2-64), and ranged from 217 to 2040 pCi/L at well 03-B-13 (Figure D-2.2-71) from 2006 to mid-2008.

Tritium in the Regional Aquifer

Background concentrations of tritium are less than analytical detection (0.29 pCi/L, using electrolytic enrichment, University of Miami) within the regional aquifer (Longmire et al. 2007, 096660). Therefore, background is essentially the detection limit of 0.29 pCi/L. Elevated above-background concentrations of tritium are reported within the regional aquifer downgradient from sites within Pajarito Canyon. Concentrations of tritium are less than analytical detection in samples collected from wells R-17 (Figure D-2.2-86) and R-20 (Figure D-2.2-98), indicating that a modern component for groundwater younger than 1943 is not present in the regional aquifer at these two wells.

Concentrations of tritium ranged from less than the detection limit (0.29 pCi/L) to 7.34 pCi/L in groundwater samples collected from well R-18 (Figure D-2.2-92). Groundwater samples collected at well R-18 since December 2007 have consistently shown detected tritium with concentrations ranging from 0.32 to 5.56 pCi/L. These detections of tritium support the presence of an increasing fraction of modern water with apparent groundwater ages more recent than 1943. The apparent age of this modern fraction is not known using available tritium concentrations. Two other contaminants, including RDX and nitrate plus nitrite, are increasing slightly in concentration at R-18.

Tritium was measured in several samples collected from wells R-32 and R-23. The highest concentration of tritium detected at well R-32 (Figure D-2.2-116) was 2.84 pCi/L; however, most of the samples collected from the well did not contain tritium. At well R-23 (Figure D-2.2-110), the highest concentration of tritium was 0.89 pCi/L and the duplicate sample contained 0.80 pCi/L.

Concentrations of tritium range from 0.32 to 76.61 pCi/L at well R-22 (Figure D-2.2-104) screens 1, 2, and 5, with the most consistent concentrations of tritium found in screens 1 and 5. Concentrations of tritium are decreasing in screen 5 from 18.49 to 3.16 pCi/L from 2001 to 2008, resulting from radioactive decay and groundwater mixing. Even though the well is impacted from residual drilling fluid effects, it is unlikely that reduction of tritium to hydrogen gas has taken place, considering that there are 10^{18} hydrogen atoms per each tritium atom produced cosmogenically. One liter or kilogram of water contains 55.6 moles of water, with 6.17 moles comprising two hydrogen atoms, which are 3.72×10^{24} atoms of hydrogen. There is a very high probability that hydrogen atoms in water will be reduced before tritium, based on the overwhelming number of hydrogen atoms compared with tritium atoms. The source(s) of tritium at R-22 is not known with certainty but may include Pajarito or Mortandad Canyons and potentially TA-54. Installation of wells R-39 and R-41 near R-22 is anticipated to help resolve this issue.

Detected concentrations of tritium range from 0.35 to 45 pCi/L at the 4-series springs (Figures 158, D-2.2-164, D-2.2-170, D-2.2-176, and D-2.2-182), including Spring 4 (9.1 to 11.2 pCi/L), Spring 4A (0.35 to 0.99 pCi/L), Spring 4AA (2.11 to 3.19 pCi/L), Spring 4B (27 to 45 pCi/L), and Spring 4C (7.92 to 11.3 pCi/L). All of the tritium analyses using electrolytic enrichment are consistently elevated above background concentrations (<0.3 pCi/L) for the regional aquifer. The source of tritium at the 4-series springs is not known, but may include sources in Pajarito Canyon or possibly even watersheds to the north of Pajarito Canyon. Other contaminants, including perchlorate and nitrate plus nitrite are also detected above background at the 4-series springs. Additional sources contributing to tritium, perchlorate, and nitrate in these springs may include canyons to the north, including Mortandad, Sandia, and Los Alamos Canyons.

7.2.2.4 Summary of Groundwater-Dating Studies

This section summarizes groundwater-dating studies using tritium/helium-3 and carbon-14 for samples collected from perched intermediate groundwater and the regional aquifer beneath the Pajarito watershed (Longmire et al. 2007, 096660 and Dale et al. 2008, 102797). The tritium/helium-3 dating method provides an apparent age of groundwater younger than 65 yr since 2008, or post-1943 for the Los Alamos area. The Laboratory began tritium discharges in 1943, and 1943 is used as the oldest date for the modern component in groundwater-dating studies conducted at Los Alamos. Groundwater younger than 1943 is the modern fraction and can comprise up to 100% of groundwater (alluvial groundwater and in some cases perched intermediate groundwater). Carbon-14 provides average age estimations for groundwater predating 1943, consisting of the submodern fraction, ranging from 600 to 30,000 yr before present. Regional aquifer groundwater that has not experienced recent recharge since 1943 is entirely submodern in age, which is common at Los Alamos (numerous background monitoring and supply wells). Regional aquifer groundwater that has experienced recharge since 1943 can have a mixed age consisting of modern and submodern components. This type of groundwater can have an average age of several thousand years but also contain tritium and other contaminants. Groundwater pumped from regional aquifer monitoring wells having a mixed age occur downgradient of industrial effluent releases in Pueblo, Los Alamos, Sandia, Mortandad, and Pajarito Canyons and Cañon de Valle. Other mobile contaminants, including nitrate, bromide, perchlorate, chloride, sulfate, and uranium, are used as anthropogenic tracers in the absence of measurable tritium to qualitatively evaluate the presence of a modern component in perched intermediate groundwater and the regional aquifer. The regional aquifer is dominated by submodern ages ranging from 570 (R-18) to 13,005 yr (R-24) beneath the Pajarito Plateau (Dale et al. 2008, 102797). The modern component present in the regional aquifer ranges up to 36%, based on anthropogenic average concentrations of chloride at R-28 in Mortandad Canyon (Dale et al. 2008, 102797).

Occurrence of surface water in the Pajarito watershed starts in upper Pajarito Canyon at PC Spring. Groundwater samples collected from PC spring have apparent ages ranging from 0.38 to 1.25 yr (Longmire et al. 2007, 096660), which is consistent with the spring's position near the eastern rim of the Valles Caldera. Groundwater discharging from PC Spring is entirely modern in age. Most of the springs discharging in the Sierra de los Valles are modern in age except for Campsite and Barbara Springs that have mixed ages (Longmire et al. 2007, 096660).

Groundwater samples collected from the 4-series springs have apparent ages ranging from 1.32 to 61 yr, indicating that the springs discharge groundwater that is characterized by flow paths of different lengths or mixed sources (Longmire et al. 2007, 096660). Ranges of apparent ages for Spring 4 (10.7 to 17.4 yr), Spring 4A (46.4 and 61.0 yr), Spring 4AA (17.6 to 40.3 yr), Spring 4B (1.3 to 11.0 yr), and Spring 4C (2.5 to 21.8 yr) are controlled by variation in the position or location of recharge to each saturated zone from which the springs discharge. The length of a given groundwater flowpath depends both on location of recharge and the hydraulic properties of aquifer material. Lower concentrations of tritium at a given spring indicate longer flowpaths from the area of recharge to the point of spring discharge. The conceptual site model for groundwater flow paths to the 4 series springs proposed by Longmire et al. (2007, 096660) consists of "stair-step" recharge through the overlying vadose zone occurring at different locations within the Pajarito watershed. An alternative conceptual site model advocates that groundwater discharging at the 4 series springs originates from areas to the north of the Pajarito watershed. In this case, regional groundwater can be mixed within or to the north of the Pajarito watershed with locally infiltrating precipitation or intermediate waters. Groundwater within the regional aquifer generally flows from west to east-southeast beneath the Pajarito watershed.

Several regional aquifer wells and intermediate well R-23i were sampled for carbon-14 analyses. Groundwater samples collected from R-23i have average ages of 1485 yr (screen 1) and 1145 yr (screen 2), with the saturated zone at screen 2 possibly having a higher hydraulic conductivity than the saturated zone at screen 1. Groundwater samples collected from R-18, R-17(screen 1), R-20(screen 1), R-32 (screen 1), and R-23 have average ages of 570, 2356, 3240, 2786, and 4069 yr, respectively (Dale et al. 2008, 102797). Recharge from surface water, alluvial groundwater, and possibly perched intermediate groundwater in Pajarito Canyon most likely produces younger average ages at R-32 (screen 1) and R-23. Regional aquifer groundwater flowing from the northwest (Los Alamos, Sandia, and Mortandad Canyons) to the southeast may mix with groundwater beneath Pajarito Canyon, potentially influencing the carbon-14 dates for R-32 and R-23. Position or location of recharge, groundwater-flow directions, and hydraulic properties of each of the saturated zones also influence average ages of groundwater in the Pajarito watershed as measured by carbon-14.

Average ages of groundwater discharging from the 4-series springs range from 2159 to 6592 yr before present. Ranges of average ages for Spring 4 (2874 and 2934 yr), Spring 4A (6361 and 6592 yr), Spring 4AA (4920 and 5376 yr), Spring 4B (2159 yr), and Spring 4C (3531 yr) are controlled by groundwater mixing between recharge water and regional aquifer groundwater beneath the Pajarito Plateau.

8.0 RISK ASSESSMENTS

This section presents the methods used to evaluate the potential for adverse ecological and human health risks from contaminants in sediment and surface water. Risk characterization results, uncertainty analysis, and risk assessment summary are also provided for each assessment.

8.1 Baseline Ecological Risk Assessment

Biological data were collected in the Pajarito watershed reaches to evaluate the potential for adverse ecological effects from contaminants in sediment and persistent surface water. A biological investigation work plan was developed based on the application of the eight-step EPA Ecological Risk Assessment Guidance for Superfund (ERAGS) (EPA 1997, 059370) to COPECs in sediment and persistent surface water (LANL 2006, 093553).

Steps 1 and 2 of ERAGS include the screening-level ecological risk assessment (SLERA) (LANL 2004, 087630), which identifies COPECs and ecological receptors potentially at risk. Ecological screening results based on the comparison of ESLs with available sediment and water data are provided in the approved biota investigation work plan (LANL 2006, 093553) and in the Phase 2 sediment sampling report (LANL 2007, 095408). Also presented in the biota investigation work plan is a comparison of available data with DOE Biota Concentration Guidelines (BCGs) for radionuclides (DOE 2002, 085637; DOE 2004, 085639). These screening-level assessments identified COPECs and formed the basis for proceeding to the baseline ecological risk assessment (ERAGS Steps 3 to 8).

Steps 3 and 4 of ERAGS comprise problem formulation and study design, which include refining the list of COPECs, developing a conceptual site exposure model, selecting assessment endpoints, and selecting associated measures of effect and exposure. The study design required for these measures was included in the approved biota investigation work plan (LANL 2006, 093553). Aspects of study design were modified, based on field verification of the design (ERAGS Step 5) and based on the results of the Phase 2 sediment sampling (LANL 2007, 095408). The original plan and its modifications were approved by NMED (2007, 096332; NMED 2007, 096474). Deviations to the original biota work plan are discussed in Section 8.1.2. ERAGS Steps 6 and 7 comprise the implementation of the study design, analysis of

ecological exposure and effects, and risk characterization. ERAGS Step 8 is risk management, and the conclusions that may lead to risk management activities are documented in Section 9.

8.1.1 Problem Formulation

This section addresses the baseline ecological risk assessment problem formulation, which is Step 3 of ERAGS. Problem formulation was presented in Appendix D of the approved biota investigation work plan (LANL 2006, 093553, pp. D-1-D-12). Problem formulation includes refinement of the list of COPECs, a literature search on known ecological effects, the conceptual site exposure model, and the selection of assessment endpoints and associated measures. Problem formulation elements are summarized in the following sections.

8.1.1.1 Refinement of COPEC List

The third step of the ERAGS process involves refinement of the COPEC list from the screening to focus on those COPECs that have the largest impact on the potential ecological risk. As explained in the SLERA methods document (LANL 2004, 087630, p. 31), the criterion for retaining a COPC as a COPEC is a hazard quotient¹ (HQ) greater than 0.3. The ESL screening excludes only COPCs with an HQ less than or equal to 0.3, which are COPCs for which no potential for ecological risk exists. To determine whether areas of the canyon may pose a potential risk to ecological receptors, and therefore what areas should be included within the scope of the biota investigation, the criterion of an HQ greater than 3 was used. This criterion of 3 is based on the geometric mean of the ratio between the no observed adverse effect level (NOAEL) and the lowest observed adverse effect level (LOAEL) (Dourson and Stara 1983, 073474). An HQ greater than 3 represents levels that may impact receptors and is therefore appropriate for determining which COPECs should be included in site-specific biota studies in the Pajarito watershed reaches. Concentrations corresponding to LOAELs represent levels where impacts to individuals or populations may occur, and these levels represent a more appropriate criterion for determining which COPECs should be included in site-specific biota analyses to assess if impacts to ecological receptors have occurred. The same criterion of an HQ greater than 3 was used to refine the list of COPECs for the baseline studies conducted in Los Alamos and Pueblo Canyons (LANL 2004, 087390, p. 8-2) and Mortandad Canyon (LANL 2006, 094161, p. 96). Receptors representing threatened and endangered (T&E) species are evaluated versus an HQ greater than 1 to ensure protection of each individual within the population.

The ecological risk assessment considers the potential for adverse effects based on affected media in the Pajarito watershed. The affected media include sediment and surface water; these media were evaluated to determine study design COPECs. There are both terrestrial and aquatic exposures from sediments. Most sediment deposits have well-developed terrestrial ecological communities and only some sediment deposits support aquatic ecological communities (see Section 8.1.1.3 for more information). No study design COPECs were retained from the evaluation of surface-water data because most aquatic COPECs identified in the water screening (see LANL 2006, 093553, Appendixes B and D) are also sediment COPECs, and most of the aquatic community receptors in the watershed are primarily sediment dwelling.

Selection of study design COPECs for soil was based on comparison of the maximum detected concentrations in all geomorphic units within a reach with the minimum soil ESL. Active channel

¹ The hazard quotient is the ratio of exposure to an adverse effects level; a hazard quotient greater than 1 indicates the potential for adverse ecological effects. Study design COPECs for threatened and endangered species are based on HQ>1 and study design COPECs for other species are based on HQ >3.

sediments may have terrestrial exposure pathways because of the transient nature of water flow in the channels in this watershed; therefore, concentrations in the active channel geomorphic unit (c1) were included in the screening for terrestrial receptors. The 20 study design COPECs for soil identified in the approved biota investigation work plan and augmented in the Phase 2 summary report are perchlorate, antimony, barium, cadmium, chromium, copper, cyanide (total), lead, mercury, thallium, vanadium, zinc, bis(2-ethylhexyl)phthalate, di-n-butyl phthalate, Aroclor-1248, Aroclor-1254, Aroclor-1260, and tetrachlorodibenzodioxin (TCDD) [2,3,7,8-], manganese, and selenium (LANL 2006, 093553, Table 5.1-2, p. 32; LANL 2007, 095408, p. 5). Study design COPECs for sediment were chosen based on a comparison of maximum detected concentrations in geomorphic unit c1 (the active channel sediments) with the ESLs for sediment. The 11 study design COPECs in sediment identified in the approved biota investigation work plan and augmented in the Phase 2 summary report include perchlorate, aluminum, cadmium, cyanide (total), iron, mercury, silver, zinc, bis(2-ethylhexyl)phthalate, di-n-butyl phthalate, and Aroclor-1248 (LANL 2006, 093553, Table 5.1-4, p. 33; LANL 2007, 095408, p. 5). No study design COPECs were identified for water in the biota investigation work plan.

Subsequent to the screening against minimum ESLs, the study design COPECs were screened against the ESLs for individual receptors to determine which COPECs should be addressed by each of the field measures. Table D-6.0-1 of the approved biota investigation work plan (LANL 2005, 089308) lists the COPECs for individual receptors; the subset of COPECs was used to determine the appropriate analytical suites and locations for each measure. The lines of evidence for investigating potential effects of COPECs by media and uncertainties relating to the lines of evidence are presented in the approved biota investigation work plan and are summarized in Table 8.1-1. The COPECs and analytical suites associated with each measure are described in the discussion of each individual field measure in Section 8.1.2. The receptors potentially at risk from exposure to soil COPECs include plants, soil invertebrates (earthworms), small mammals, mammalian carnivores, omnivorous birds, and carnivorous birds representing a T&E species, the Mexican spotted owl (*Strix occidentalis lucida*). Receptors at potential risk from exposure to sediment include the swallow (which also represents a T&E species, the southwestern willow flycatcher [*Empidonax traillii extimus*]), the bat, and the aquatic community (which represents a number of aquatic species).

8.1.1.2 Literature Search of Known Ecological Effects

The following is a synopsis of the screening ecological receptors with the highest HQs (HQ >3) and the feeding guilds they represent. This section reviews both the original COPECs from the approved biota investigation work plan and the new COPECs designated based on the screening of the Phase 2 sediment data. The toxic effects are based on toxicity studies used as the basis for the ESLs as described in the Ecorisk Database Version 2.2 (LANL 2005, 090032). The HQs for screening against individual receptors are in Tables D-2.2.1 through 2.2.20 of the approved biota investigation work plan (LANL 2006, 093553, pp. D-26–D-52).

Mammals

Soil Pathway Receptors

The deer mouse represents mammalian omnivores and had HQs greater than 3 for cadmium, thallium, and Aroclor-1248. The receptor representing the mammalian ground invertebrates is the montane shrew. This receptor has HQs greater than 3 for antimony, cadmium, thallium, and Aroclor-1248. The reaches with the highest HQs were AEN-1 and TW-1E. Antimony is a study design COPEC only in reach PA-4, and Aroclor-1248 is a study design COPEC in reach TW-1E and reach TWN-1E. Cadmium and thallium

are study design COPECs in multiple reaches. The fox represents mammalian carnivores; this receptor had one HQ above 3 (for Aroclor-1248 was a study design COPEC in reach TW-1E).

Sediment Pathway Receptors

The little brown myotis bat represents mammalian aerial insectivores, and HQs greater than 3 were calculated for aluminum, cadmium, and Aroclor-1248. There is an important distinction between the mammalian aerial insectivore (bat) and the two avian insectivores (robin and swallow). The home range of the bird species has a spatial scale similar to areas within the canyon, while the home range of the bat is much larger (LANL 2004, 087630, p. 39). Studies to directly address potential risk to the bat were not proposed in the biota plan, but information on COPEC concentrations in prey (insects from bird nest boxes) will be evaluated to determine potential exposure of the bat to COPECs through insect prey.

Birds

Soil Pathway Receptors

The American robin is modeled as the representative for invertevorous birds, omnivorous birds, and herbivorous birds. The lowest ESLs for the COPECs in the Pajarito watershed are associated with the invertevorous robin, which is modeled with a diet consisting solely of earthworms. HQs above 3 for the robin were calculated in multiple reaches for cadmium, copper, total cyanide, lead, mercury, vanadium, zinc, Aroclor-1248 (in one reach only), Aroclor-1254 (in one reach only), bis(2-ethylhexyl)phthalate, and di-n-butyl phthalate.

The kestrel modeled with a 100% flesh diet is used to represent all avian top carnivores, including the Mexican spotted owl. Because this receptor represents a T&E species, an HQ greater than 1 (instead of an HQ greater than 3) was used to determine study design COPECs. Total cyanide, mercury, and Aroclor-1248 had HQs greater than 1 for the kestrel modeled as a surrogate for the Mexican spotted owl. Total cyanide was a potential study design COPEC in more than one reach, but cyanide is extremely difficult to measure in samples of biological tissue; in addition, the highest detected concentration was obtained in the background reach PA-0 and suggests non-Laboratory sources for this contaminant. Therefore, this COPEC was not selected for the basis of the study design for bioaccumulation measures in this biota investigation. Mercury had an HQ greater than 1 only in reach AEN-1. Aroclor-1248 had an HQ greater than 1 only in reach TW-1E.

Sediment Pathway Receptors

The violet-green swallow represents avian aerial insectivores and also serves as a surrogate for the southwestern willow flycatcher, a T&E species for which habitat exists within the Pajarito watershed. HQs greater than 3 for active channel sediment and associated wetlands were used to determine study design COPECs for the violet-green swallow, and HQs greater than 1 were used to determine study design COPECs for the southwestern willow flycatcher. Study design COPECs for the flycatcher are aluminum, total cyanide, mercury, zinc, Aroclor-1248, Aroclor-1254, bis(2-ethylhexyl)phthalate, and di-n-butyl phthalate.

Terrestrial Plants

The plant is the representative for primary producers and had HQs greater than 3 in soil for antimony, barium, chromium, copper, manganese, selenium, silver, thallium, vanadium, and zinc. HQs greater than 3 for at least one of these COPECs were found in all the reaches sampled within the Pajarito watershed.

Terrestrial Invertebrates

The earthworm is the representative of soil invertebrates and had HQs greater than 3 in soil for chromium, copper, and mercury. Elevated HQs for chromium and copper were seen in several reaches, but the HQ for mercury was elevated only in reach AEN-1.

Aquatic Community Organisms

Sediment Pathway Receptors

ESLs for sediment are based on risk to the aquatic community instead of an individual receptor. The concentrations of COPECs in channel sediment are compared with aquatic community ESLs in Table D-2.2-13. HQs greater than 3 were calculated in sediment for barium, total cyanide, iron, manganese, silver, anthracene, Aroclor-1254, Aroclor-1260, benzoic acid, and DDT[4,4'-].

8.1.1.3 Conceptual Exposure Model

Section 2.2 of the approved biota investigation work plan (LANL 2006, 093553) discusses the types of habitats and receptors found within the Pajarito watershed. Many of the reaches within the Pajarito watershed have ponderosa pine as the dominant overstory vegetation, although some reaches also contain mixed conifer, piñon, or juniper trees depending on elevation and microclimate. As discussed in Section 3.0 of the approved biota investigation work plan (LANL 2006, 093553), surface water is present in a variety of contexts throughout the Pajarito watershed, including wetlands and perennial streams fed by springs. Detailed information on the habitat types is presented in the ecological scoping checklist (LANL 2006, 093553, Appendix C). Historical contaminant releases to the soils, sediments, and persistent surface water in the Pajarito watershed have occurred from multiple SWMUs and AOCs, primarily through releases of effluent or open-air explosives testing. For ecological receptors, the primary impacted media in the canyons are sediment deposits and surface water. Alluvial groundwater is not assessed separately because alluvial groundwater in the Pajarito watershed mixes with surface water in the channel, and ecological receptors are directly affected only by COPECs in surface water. Therefore, the investigations of surface-water COPECs include COPECs that might be present in alluvial groundwater.

Only active channel sediments, wetland sediments, and surface water potentially have complete exposure pathways to truly aquatic species, whereas terrestrial animals and plants are exposed to COPECs in surface water, soil, or sediment. Contaminants have several potential exposure pathways to reach receptors.

Exposure of terrestrial receptors can occur through the following pathways:

- Air—through respiration of vapors, inhalation, and deposition of particulates
- Surface soil—through root uptake and rain splash on plants, food web transport to plants and animals, incidental ingestion of soil, dermal contact with contaminated soil, and external irradiation
- Persistent surface water and sediments—through root uptake and rain splash on plants, food web transport to animals, incidental ingestion of water and sediment, dermal contact with contaminated water or sediment, and external irradiation from sediment

The major soil-related exposure pathways are plant uptake, food web transport, incidental ingestion of contaminated soil, and external gamma radiation exposure. Water and sediment pathways are less important to terrestrial receptors because of the limited temporal and/or spatial extent of persistent

surface water in the watershed. Exposure to vapors does not represent a significant pathway because of the infrequent detection of VOCs in the watershed, the low VOC concentrations measured in sediment and water, and the rapid volatilization of VOCs in sediments near the ground surface. Exposure to airborne particulates is a minor pathway because of the limited amount of contamination at the ground surface and the dense plant cover in some reaches.

Also minor are the remaining pathways related to exposure to surface soil (dermal contact) and surface water and sediment (food web transport, incidental ingestion of contaminated sediment and water, dermal contact, and external gamma radiation exposure) because of the limited amount of contamination at the ground surface or in surface water. In addition, soil exposure pathway analysis performed by EPA to support the development of its ecological soil screening level has shown that inhalation and dermal pathways contribute a small fraction of the dose obtained orally (EPA 2003, 085643). All complete exposure pathways are at least qualitatively evaluated in the assessment because some of the measures proposed in this investigation are field measures of effect or exposure.

8.1.1.4 Assessment Endpoints

Assessment endpoints consist of an entity (a receptor species) and an attribute (survival, growth, or reproduction) of the entity being assessed. Seven assessment endpoints for the Pajarito watershed are identified based on the study design COPECs and the conceptual site exposure model. These endpoints were selected to represent T&E receptors (the Mexican spotted owl and the southwestern willow flycatcher) as well as receptors that are representative of the terrestrial and aquatic food web in the Pajarito watershed. The site conceptual model indicates that ingestion exposure pathways, in particular, food web transport, are important pathways for COPECs. Assessment endpoints were developed for the five terrestrial feeding guilds (including aerial insectivores) that represent the receptors with the highest HQs, as well as for the surrogates for the T&E species. Because many aquatic environments in the Pajarito watershed are not perennial and rely on persistent water from stormwater or snowmelt runoff, a single assessment endpoint for the aquatic study design was selected. The seven assessment endpoints (AE1 through AE7) are as follows:

- survival and reproduction of the Mexican spotted owl (AE1)
- health and reproductive success of avian ground invertevore feeding guild species (e.g., American robin, bluebird) (AE2)
- survival of mammalian invertevore and omnivore feeding guild species (e.g., shrews and deer mice) (AE3)
- survival and growth of detritivore species (earthworms) (AE4)
- survival and growth of native plant species (AE5)
- survival and reproduction of the southwestern willow flycatcher (AE6)
- abundance and survival of the aquatic community in the reaches of the Pajarito watershed that retain surface water long enough to support aquatic communities (AE7)

Assessment endpoints are used as the basis for developing the measures of exposure and measures of effects. The measures evaluate impacts to the attributes of survival, growth, or reproduction in the receptor species and in the feeding guilds that those receptor species represent. The measures include field, laboratory, and model data. Evaluation of AE3 (survival of small mammal species) is based on comparison of concentrations of COPECs in soil and sediment in Cañon de Valle, the Los Alamos and Pueblo watershed, and the Mortandad watershed with the concentrations of those COPECs in the Pajarito watershed. Studies in these canyons showed no effect on small mammal populations from the

concentrations seen in soil and sediment. For the biota investigation in the Pajarito watershed, the measures are based on the extension of the biota investigations done in the Los Alamos and Pueblo watersheds (LANL 2004, 087390) and in the Mortandad watershed (LANL 2005, 089308).

8.1.2 Study Design, Field Verification, and Site Investigation

This section discusses the ecological risk assessment study design, field verification, and site investigation; this encompasses ERAGS Steps 4 and 5 and the first part of Step 6. Biological data were collected as measures of exposure and effect (lines of evidence) to evaluate the potential for adverse ecological effects from contaminants in soil, sediment, and persistent surface water. The initial design of each study is documented in the approved biota investigation work plan (LANL 2006, 093553). Figure 8.1-1 shows the reaches and sample locations in the Pajarito watershed. The rapid bioassessment characterization studies were collocated with the chironomid toxicity tests indicated in Figure 8.1-1. Table 8.1-2 shows the reaches included in each type of study, as well as the study design COPECs used as the basis for including that reach for that type of study.

8.1.2.1 Soil and Sediment Characterization

Samples of sediment were collected from the locations in the Pajarito watershed used for laboratory toxicity tests. Appendix B (Table B-3.0-1) shows the reach, location identification (ID), and geomorphic unit associated with each of these samples. For the earthworm and plant toxicity tests, discrete samples were collected from 0 to 30 cm (0 to 1 ft) for the toxicity assays and for the analytical analysis of the same samples. Samples for the earthworm and plant toxicity tests were collected from geomorphic units outside the active channel (generally c2, c3, or f1 units). Sediment samples for the *Chironomus tentans* toxicity tests were collected from 0 to 15 cm (0 to 0.5 ft) in the c1 geomorphic unit (the active channel) to represent the sediment to which these aquatic organisms would be exposed.

8.1.2.2 Nest Box Studies

An avian nest box monitoring network has existed at the Laboratory and its vicinity since 1997; the network includes both potentially contaminated and noncontaminated areas. As part of the baseline ecological risk assessment for the Pajarito watershed, additional nest boxes were placed in the canyon bottoms or canyon bench areas within Pajarito Canyon and its major tributary canyons. Figure 8.1-1 shows the boxes within the Pajarito watershed sampled for the biota studies. Both the western bluebird (*Sialia mexicana*) and the ash-throated flycatcher (*Myiarchus cinerascens*) occupy these boxes. Measures collected using the nest box network included field measures of effect on reproductive success of these avian species (including clutch size, fledgling success, growth of fledglings, etc.) and measures of exposure through analysis of COPEC concentrations in unhatched western bluebird eggs and unconsumed prey (insects) collected within the boxes. Appendix B (Table B-3.0-3) shows the egg and insect samples collected for analyses within the Pajarito watershed; the locations of the boxes within the reaches are shown in Figure 8.1-1. Boxes in the Cañada del Buey watershed (near TA-51) and boxes from two areas outside the Laboratory (the Los Alamos Golf Course and the Guaje Pines Cemetery (LANL 2004, 087390, Figure 8.1-1) were also included in the study for reference. Eggs from individual boxes within a reach were submitted as samples. In some cases, individual boxes contained sufficient material for analysis, but in other cases insects from more than one box in a reach were combined to obtain sufficient sample size for analysis. Table 8.1-3 shows a summary of the eggs and insects collected per reach.

Because of sample size limitations, egg and insect samples were analyzed only for metals. These measures were collected to evaluate AE2, the endpoint for avian ground invertebrates. The COPEC concentrations in nest box insects were used as a measure for AE6 for the avian insectivore (southwestern willow flycatcher) and the mammalian insectivore (the occult little brown myotis bat). Results of the field measures of effect through reproductive success are discussed in Section 8.1.3.3. The measures of exposure through COPEC concentrations measured in insects are discussed in Section 8.1.3.2, and exposure based on COPEC concentrations in eggs is discussed in Section 8.1.3.3.

8.1.2.3 Earthworm Toxicity Tests

Sediment collected from the 0- to 30-cm- (0- to 1-ft-) depth interval was used for the earthworm toxicity tests (a measure for AE4). The earthworm tests used the standard American Society for Testing and Materials (ASTM) Method E1676-97. The toxicity tests compared the growth and mortality of the earthworms from the seven reaches shown in Table 8.1-2 with the reference site in reach PA-0. As shown in the table, the reaches were selected to represent a gradient of concentrations for COPECs associated with both the soil invertebrate receptor and the mammalian and avian receptors that feed on the soil invertebrate. Earthworms were sent to an analytical laboratory for chemical analyses (see Appendix B, Table B-3.0-2, for a crosswalk of earthworms, the bioassay, and the soil samples). Section 8.1.3.5 discusses the results of the statistical analysis of the growth and mortality between sites and comparison to earthworm toxicity tests performed in the watersheds of Los Alamos, Pueblo, and Mortandad Canyons (LANL 2004, 087390; LANL 2006, 094161).

8.1.2.4 Seedling Germination Tests

Sediment collected from the 0- to 30-cm- (0- to 1-ft-) depth interval was used for the plant toxicity tests (a measure for AE5). The plant toxicity tests used the standard ASTM Method E1963-98. The plant toxicity tests compared survival rates and shoot and root mass in plants grown in soil from the same locations used for the earthworm toxicity tests with plants grown in the soil sample from the background site (reach PA-0). The tests used perennial ryegrass (*Lolium perenne*), which is one of the standard test species for the seedling germination test. The species was selected based on the availability of seeds and the experience of the bioassay laboratory in successfully completing tests with ryegrass. The results from the ryegrass test are not directly comparable to tests conducted in the Los Alamos, Pueblo, and Mortandad watersheds with yarrow (*Achillea millefolium* L. var *occidentalis*) (LANL 2004, 087390; LANL 2006, 094161). Section 8.1.3.6 discusses the results of the statistical analysis of the growth and mortality between sites.

8.1.2.5 Chironomus tentans Toxicity Test

Sediment samples from the reaches shown in Table 8.1-2 were used in the EPA Method 100.2 (EPA 2000, 073776) 10-d growth and survival test with the larval insect *Chironomus tentans*. Each sediment sample was tested at 100% only; dilution series were not run on the sites. Standard controls and reference toxicants were included. The endpoints for this test include both survival and growth (as ash-free dry weight). The results of the test are discussed in Section 8.1.3.7.

8.1.2.6 Rapid Bioassessment Characterization

Rapid bioassessment characterization was conducted in three reaches in the Pajarito watershed that had sufficient flow to potentially support aquatic macroinvertebrate communities (EPA 1999, 073728) using the EPA Rapid Bioassessment Protocol (1999, 073728). Collection of aquatic macroinvertebrates was conducted in association with the bioassessment. Collection and assessment were attempted at all four

reaches specified in Table 8.1-2 in May 2008, but because of absence of water, invertebrates were not collected from reach AW-1. In addition, reach TWN-1E was specified in the approved biota investigation work plan (LANL 2006, 093553), but reach TW-2E downstream was sampled because of absence of water upstream. The approved biota investigation work plan (LANL 2006, 093553) specified use of a Hess sampler to collect aquatic macroinvertebrates when sufficient water was present to use this sampler. However, only reach PAS-2E had sufficient water to use the Hess sampler. The Hess sampler is needed to collect data for comparison to the NMED Stream Condition Index (SCI); therefore, only aquatic macroinvertebrates from reach PAS-2E could be compared with the SCI. The SCI compares sites with a reference condition, which is based on historical data from New Mexico streams. Semiquantitative sampling was done at the other sites using a D-frame dip net to determine taxonomic composition of macroinvertebrates.

8.1.2.7 Spatial Modeling Using ECORSK.9

The ECORSK.9 model was used to model HQs and hazard indices² (HIs) across the Pajarito watershed for the Mexican spotted owl and southwestern willow flycatcher as presented in Gonzales et al. (2008, 102790). ECORSK.9 includes both canyon and noncanyon sources as well as measured and interpolated concentrations of COPECs from these sources. The model estimates exposure based on an environmental exposure unit that consists of foraging throughout the home range centered on known or potential nest sites input into the model. For the Mexican spotted owl, the model restricted the nest sites within the buffer area for this T&E species. For the southwestern willow flycatcher, the model restricted the nest sites within the wetland areas designated as potential flycatcher habitat. The model produces mean total HIs that provide an estimate of risk to populations. For evaluating T&E species, risk to individuals and therefore the number of individual grid cells with elevated HIs are better indicators of locations and COPECs that may need additional investigation. The model calculates both unadjusted HQs and HIs and adjusted HQs and HIs; the adjusted values do not include the contribution of background concentrations of COPECs. For many organic chemicals, nondetects constituted more than 75% of the data set values, resulting in detection limits heavily influencing the HQ and HI values. The first scenario was run with nondetects for organic chemicals treated as zeros to focus the results on the actual detected COPECs in the model. For comparison purposes, a second scenario evaluated all nondetects as values at one-half of their detection limit.

8.1.3 Characterization of Exposure and Effects

This section discusses the baseline ecological risk assessment characterization of exposure and effects, which represents the second part of ERAGS Step 6. This section provides the results from the studies and their interpretation, as well as supporting information in tables and figures. Revised calculations of dose to predators based on concentrations of COPECs in prey are also presented in this section.

8.1.3.1 Mexican Spotted Owl

ECORSK.9 Model

The results of ECORSK.9 model did not indicate that there are areas of potential risk to individual Mexican spotted owls (Gonzales et al. 2008, 102790). This was true for both the unadjusted and adjusted mean HI. The adjusted mean HQ and mean HI values calculated in the first scenario (all organic nondetects treated as zeros, as explained in Section 8.1.2.7) are considered the most representative of

² Hazard index is a sum of hazard quotients and accounts for the potential additive effects of COPECs.

potential risk from Laboratory sources to the modeled receptors, although the adjustment for background made little difference for the HQ and HI values for the owl. The adjusted total mean HI with nondetects treated as zeros for the owl is 0.1; no COPECs had an HQ >0.1. The HI was <1 in 100% of the focal points. The area with the highest adjusted HI values (HI from 0.5 to 0.6), indicating greatest potential for adverse effects on the Mexican spotted owl, was in Pajarito Canyon and its tributaries, including reaches AEN-1, AES-1, and PA-1E.

Concentrations of COPECs in Prey

COPECs for the Mexican spotted owl were identified in the biota plan (LANL 2006, 093553, p. D-6) and the Phase 2 summary report (LANL 2007, 095408, p. 5). Total cyanide, mercury, Aroclor-1248, Aroclor-1254, and di-n-butylphthalate met the criterion for study design COPECs (HQ >1 for a T&E species). Perchlorate was also identified as a COPEC because there is no avian toxicity reference value (TRV) for this COPEC; this COPEC is evaluated in a qualitative manner in the uncertainty analysis (Section 8.1.4.2).

Total cyanide, which was a study design COPEC, was not requested for tissue analyses because the analytical method used to analyze for cyanide is inappropriate for this matrix. The analytical methods used for measuring cyanide concentrations follow EPA SW-846 Method 9010A or 9012A, "Total and Amenable Cyanide." These methods were specifically developed and validated for solid samples, such as sediment, soil, waste, and leachate. Biological samples have not been validated for these methods; it is not reliable to apply analytical methods to matrices other than those recommended and previously validated. Potential problems that may arise if these methods are used for biological samples include interference from thiocyanate, found in blood plasma. High levels of aldehydes and ketones can also pose interference problems. In addition, fatty acids (lipids) found in high concentrations in biological tissues interfere with the distillation step. This interference can result in difficulty in finding the titration endpoint, used for quantitative measurement, and makes quantitation difficult. Cyanide is evaluated in a qualitative manner in the uncertainty analysis (Section 8.1.4.2). Analytical results for the other COPECs are provided in Appendix C.

Although small mammals were not sampled in the Pajarito watershed, there are PCB and mercury tissue results for small mammals collected in the Los Alamos, Pueblo, and Mortandad watersheds that can be used for comparison. There are no tissue data available for di-n-butylphthalate; this COPEC is evaluated in a qualitative manner in the uncertainty analysis (Section 8.1.4.2). Sediment concentrations of PCBs and mercury are greater in the Los Alamos, Pueblo, and Mortandad watersheds compared with the Pajarito watershed (Table 8.1-4). Only one of the PCB mixtures (Aroclor-1260) was detected in mammal tissues. The maximum concentration of these COPECs in the Pajarito watershed is less than the maximum concentrations in the other watersheds. The exposure assessment for the Mexican spotted owl or red fox in both the Los Alamos and Pueblo Canyons and Mortandad Canyon investigation reports (LANL 2004, 087390; LANL 2006, 094161) resulted in HQs less than 1, which does not indicate the potential for adverse effects from these COPECs.

8.1.3.2 Aerial Insectivores

ECORSK.9 Model for the Southwestern Willow Flycatcher

In the ECORSK.9 model, a number of grid cells within the Pajarito watershed with elevated HIs indicated there may be areas of potential risk to southwestern willow flycatchers (Gonzales et al. 2008, 102790). The adjusted mean HQ and mean HI values calculated in the first scenario (all organic nondetects treated as zeros, as explained in Section 8.1.2.7) are considered the most representative of potential risk from Laboratory sources to the modeled receptors. The adjusted mean HI value for the flycatcher was 2.3 for

the first scenario. The dominant COPECs were cadmium (adjusted HQ = 0.58), vanadium (adjusted HQ = 0.46), Aroclor-1254 (adjusted HQ = 0.23), copper (adjusted HQ = 0.22), lead (adjusted HQ = 0.19), and cyanide (adjusted HQ = 0.16). HIs were ≥ 1.0 in 69% of the grids; none of these HIs were greater than 10. The flycatcher was modeled only for areas that contain potential flycatcher habitat; therefore, the area with elevated HIs are limited to the lower part of Pajarito Canyon above NM 4 (reach PA-4).

Concentrations of COPECs in Prey for the Southwestern Willow Flycatcher

This section estimates the potential dose to the southwestern willow flycatcher using the concentrations in the insects collected from the nest boxes or concentrations in worms from the earthworm bioaccumulation bioassay.

COPECs for the southwestern willow flycatcher were identified in the approved biota investigation work plan (LANL 2006, 093553, p. D-6) and the Phase 2 summary report (LANL 2007, 095408, p. 5). Aluminum, cadmium, cyanide, mercury, silver, vanadium, zinc, Aroclor-1248, Aroclor-1254, bis(2-ethylhexyl)phthalate, and di-n-butylphthalate met the criterion for study design COPECs (HQ >1 for a T&E species). Perchlorate was also identified as a COPEC because there is no avian TRV for this COPEC; this COPEC is evaluated in a qualitative manner in the uncertainty analysis (Section 8.1.4.2). For the reasons discussed in Section 8.1.3.2, cyanide was not measured in tissues and is evaluated in a qualitative manner in the uncertainty analysis (Section 8.1.4.2). Bis(2-ethylhexyl)phthalate and di-n-butylphthalate were not measured in flycatcher food due to sample mass limitations and are evaluated in a qualitative manner in the uncertainty analysis (Section 8.1.4.2).

As described in the biota investigation work plan (LANL 2006, 093553, p. D-17), the HQ is calculated by dividing the TRV for a COPEC from the Ecorisk Database, Version 2.2 (LANL 2005, 090032) by the normalized food intake times the COPEC concentration.

$$HQ = \frac{Exposure}{Effect}; \quad HQ_{pathway,COPEC} = \frac{I_{receptor,pathway} \cdot C_{pathway,COPEC}}{NOAEL_{receptor,COPEC}}; \quad \text{Equation 1}$$

where $C_{pathway,COPEC}$ is the concentration of the COPEC for the pathway (food and incidental soil) with units mg of COPEC/kg fresh weight);

$NOAEL_{receptor,COPEC}$ is the NOAEL for COPEC (mg-COPEC/kg-body weight/day); and

$I_{receptor,pathway}$ is the normalized daily intake rate for the receptor and pathway (kg-intake fresh weight/kg-body weight/day).

For the flycatcher, normalized food intake was calculated from the body weight (bw) of 12.7 g (LANL 2005, 089308, p. D-14) and estimating the food ingestion rate using the allometric equation for passerine birds from EPA's Wildlife Exposure Factors Handbook (1993, 059384, Equation 3-4). The calculated food ingestion rate is 0.0034 kg/d. This food ingestion rate is in grams of dry weight per day and was converted to fresh weight (fw) using the dry weight to fresh weight ratio for honeybees (Fresquez and Ferenbaugh 1999, 091269). The final insect ingestion rate used in the calculations for the southwestern willow flycatcher is 0.79 kg fw food/ kg bw/d. The TRVs used for the flycatcher are summarized in Appendix E-1.0.

Table 8.1-5 shows the calculated HQs for the flycatcher based on ingestion of the concentration measured in nest box insects or earthworms. In all cases, there is a single sample result for insects or earthworms in each reach. Table 8.1-5 displays all results for the food pathway if the HQ for a COPEC in any reach was greater than 1; otherwise, the results for the reach with the largest HQ are presented and the results for reach AW-1 are presented. Reach AW-1 has the largest HQ for many COPECs.

The HQs for the insect or earthworm ingestion pathway are shown in Table 8.1-5 and generally predict a much lower level of potential adverse ecological effect than the screening against ESLs did, even though HQs for six COPECs still exceed 1 (Aroclor-1248, Aroclor-1254, cadmium, mercury, vanadium, and zinc). Vanadium and zinc also had HQs greater than 1 in samples collected outside the Pajarito watershed in the Cañada del Buey, Pueblo, and Rendija watersheds (LANL 2006, 094161, p. 289). Thus, the potential for risk is calculated for vanadium and zinc in insects collected from most locations, regardless of the presence of Laboratory contaminant sources.

The potential for adverse effects based on insect data can be compared with that predicted based on earthworm data. The insect samples reflect actual exposure to birds from an area near each nest box. The earthworm data reflect the contaminants and potential for exposure from a single point in the reach. Cadmium, vanadium, and zinc were measured in both insects and earthworms. The conclusion for cadmium is similar for both food pathways; HQs for cadmium were greater than 1 at one reach based on insects and earthworms. However, the conclusions for vanadium and zinc differed; HQs based on concentrations in earthworms were less than 1 and HQs based on insects were greater than 1.

The exposure evaluation for the flycatcher also identifies reaches where COPECs have an HQ greater than 1. There were three reaches (AW-1, AEN-1, and TW-1E) where the HQ for Aroclor-1248, Aroclor-1254, cadmium, or mercury were greater than 1. The southwestern willow flycatcher has not been observed in this part of the Laboratory, so the risk is hypothetical at this time. However, further evaluation may be warranted if the flycatcher is observed to utilize this area in the future.

Estimate of COPEC Dose through Food to the Bat

Three COPECs in the Pajarito watershed reaches had HQs >3 for the bat (aluminum, cadmium, and Aroclor-1248), but the bat is not identified as an assessment endpoint because its large home range and high food ingestion rate indicate that much of a bat's food is obtained from outside the watershed. However, because nest box insect and earthworm tissues were analyzed to evaluate avian receptors, these analytical results were used to calculate the potential COPEC dose through food to the occult little brown myotis bat, as shown in Table 8.1-6. Application of earthworm concentrations to the bat exposure evaluation is protective in that the realistic diet for the bat does not include prey with such an intimate association with soil. Exposure parameters for the bat are from the SLERA methods document (LANL 2004, 087630, p. 39) and are listed in Appendix E-1.0. Aluminum was included in the analytical suite for the nest box insects and earthworms, but aluminum is only a potential COPEC in soils with a pH below 5.5 (EPA 2003, 085645); therefore, aluminum has no relevant TRV and is not included in Table 8.1-6. The TRVs used for the bat are summarized in Appendix E-1.0. The pathway HQ for Aroclor-1248 and cadmium are greater than 1 in three reaches (AW-1, AEN-1, and TW-1E; Aroclor-1248 HQ in reach TW-1E is 14, and the cadmium HQs are 3 to 4 in reaches AEN-1 and AW-1), indicating some potential for adverse effects on the bat through ingestion of insects if all insects are eaten from these reaches in the Pajarito watershed. However, considering the large home range for the bat of 100 ha or larger and the protective nature of the food data, the potential for adverse effects on the bat is greatly overstated by this simple analysis.

8.1.3.3 Avian Invertevore Feeding Guild

This section provides results for trends of COPEC concentration in sediment versus field measures for the avian invertevore feeding guild in the Pajarito watershed, such as nest success and eggshell thickness. Field measures are derived from Colestock and Fair (2005, 093691).

Nest Success

As part of the Laboratory's nest box monitoring program, a large number of field measures are collected from the nest boxes each year (Colestock and Fair 2005, 093691). Two measures related to juvenile survival were selected for comparison to concentrations of COPECs in sediment. The measures selected are percent fledged and percent female (the latter may relate to specifically PCBs as COPECs). Occupied bird boxes were found in seven reaches within the Pajarito watershed: AW-1, PAS-1E, PAS-2W, TWSE-1W, PA-W, PA-3E, and PA-4. Because nest boxes have been deployed in these reaches for 1 or 2 yr, data from all nest boxes in the Pajarito watershed have been combined for statistical analyses. Reference locations for nest box measures include boxes deployed in Cañada del Buey, the cemetery, the Los Alamos Golf cCourse, and Guaje Canyon. Data are provided for comparison purposes from nest boxes in other locations, potential impacted areas in other canyons (e.g., Los Alamos, Mortadad, and Sandia).

All species occupying the nest boxes (western bluebirds, violet-green swallows, ash-throated flycatchers, and mountain bluebirds) are included in the analysis of the measures to provide a larger data set because the overall number of occupied boxes in the reaches is fairly small. Appendix E-1.0 provides box plots comparing these two measures between species; no significant differences are seen. Because western bluebirds are the main species occupying nests, the data for the western bluebird are presented and discussed below.

Comparisons of the selected nest measures for western bluebirds between the Pajarito watershed and reference locations are shown in Figure 8.1-2 for percent fledged and Figure 8.1-3 for percent female. Boxes in these figures indicate the interquartile range of the sample results, with the upper and lower ends defined by the 75th and 25th percentiles, respectively. Horizontal lines within the boxes indicate median values, and horizontal lines above and below the boxes represent the 5th and 95th percentiles of the data. Dunnett's *t*-test results are presented in the right-hand section of each figure. The comparison circles indicate statistical differences between the tests and the reference sites. The reference site sample for the Dunnett's *t*-test is displayed as a heavy red circle, and the text for the reference site is printed in bold red text on the x-axis. Thin red circles represent samples that are not statistically different ($p < 0.05$), and the watershed names are displayed in red on the axis. Heavy gray circles represent samples that are statistically different, and these names are printed in black on the x-axis. There were no significant differences in percent fledged or percent female. These measures were recorded from 1997 to 2008; bivariate plots of each measure versus year were made and are shown in Appendix E-1.0. Variation in these measures is not biologically significant, so data from all years are included in Figures 8.1-2 and 8.1-3.

Egg Measurements

Another set of parameters collected as part of the nest box network is related to the condition of the eggs. Numerous parameters have been collected; three of these parameters were chosen for inclusion in this study. Eggshell length (in millimeters) and total egg weight correlate well with each other and provide an estimate of egg size. Eggshell thickness was also chosen because previous studies had shown that some thinning of eggshells has occurred at the Laboratory in Sandia Canyon (Fair and Myers 2002, 082655). As with the other nest measures described above, all species have been included to provide a larger data set. Appendix E-1.0 shows the comparison between species for egg length, egg weight, and eggshell thickness; the comparison shows no significant differences between species for these parameters. Appendix E-1.0 also compares length, weight, and thickness across years in bivariate plots. None of the three measures vary significantly with year, so data from all years are included in the analysis.

The measures for the eggs are compared between watersheds and are also compared with reference locations. Figures 8.1-4 to 8.1-6 show the comparisons for the western bluebirds egg measures between the Pajarito watershed locations and reference locations. The sample sizes vary between locations; however, the three measures do not show any significant differences between watersheds based on the results of the Dunnett's *t*-test (discussed above).

COPEC Concentrations in Eggs, Insects, and Worms

Concentrations measured in eggs collected from the Pajarito watershed can provide information on exposures to COPECs. However, only a single nestling was collected from a nest box in reach AW-1, and eggs were collected from two other locations in the Pajarito watershed that were not collocated with reaches. There was not sufficient information to draw conclusions regarding exposures based on a single nestling.

The insects collected from nest boxes in five reaches were analyzed for inorganic chemical COPECs. The concentrations of some COPECs reported for these nest box insects collected from reach AW-1 were greater than other Pajarito watershed insect samples and were well outside the range of concentrations reported from other canyons. Table 8.1-7 presents a comparison of COPEC concentrations and shows that the concentrations of cadmium, lead, and zinc are an order of magnitude greater than the next highest concentration reported.

The COPEC concentrations from the earthworm bioaccumulation test can be used to calculate site-specific concentration ratios (CRs); these ratios can be compared with the transfer factors (TFs) used in the calculation of the ESLs to evaluate the potential for bioaccumulation and exposures. Table 8.1-8 presents a summary of CRs versus TFs for COPECs identified for avian or mammalian invertebrates. In all cases where the TF was a default value (0.167), the CRs were less than the default value. For lead and zinc, the CRs and TFs generally agreed in magnitude and were typically less than a factor of 2 different. The CRs for mercury and PCBs did not agree, and generally the CRs for these COPECs are a factor of 10 larger than the TFs. The agreement and disagreement between the CRs and the TFs will be further evaluated in the uncertainty analysis (Section 8.1.4.2).

The remainder of this section estimates the potential dose to the robin using the concentrations in the insects collected from the nest boxes or concentrations in worms from the earthworm bioaccumulation bioassay. The equation for calculating HQs was presented in Section 8.1.3.2, and exposure parameters for the robin are from the SLERA methods document (LANL 2004, 087630, p. 37) and are listed in Appendix E-1.0.

COPECs for the robin were identified in the approved biota investigation work plan (LANL 2006, 093553, p. D-5) and the Phase 2 summary report (LANL 2007, 095408, p. 5). Cadmium, copper, cyanide, lead, mercury, perchlorate, vanadium, zinc, Aroclor-1248, Aroclor-1254, di-n-butyl phthalate, and bis(2-ethylhexyl)phthalate met the criterion for study design COPECs (HQ >3). Perchlorate was also identified as a COPEC because there is no avian TRV for this COPEC; this COPEC is evaluated in a qualitative manner in the uncertainty analysis (Section 8.1.4.2). For the reasons discussed in Section 8.1.3.2, cyanide was not measured in tissues and is evaluated in a qualitative manner in the uncertainty analysis (Section 8.1.4.2). Bis(2-ethylhexyl)phthalate and di-n-butylphthalate were not measured in robin food due to limitations of sample mass and are evaluated in a qualitative manner in the uncertainty analysis (Section 8.1.4.2). The TRVs used for the robin are summarized in Appendix E-1.0.

Table 8.1-9 shows the calculated HQs for the robin based on exposure to concentrations measured in nest box insects or earthworms. In all cases, there is a single sample result for insects or earthworms in each reach. Table 8.1-9 displays all results for the food pathway if the HQ for a COPEC in any reach was

greater than 1; otherwise the results for the reach with the largest HQ is presented and the results for reach AW-1 are presented. Reach AW-1 has the largest HQ for many COPECs.

The HQs for insect or earthworm ingestion pathway are shown in Table 8.1-9 and predict a potential for adverse ecological effect based on HQs for eight COPECs exceeding 1 (Aroclor-1248, Aroclor-1254, cadmium, copper, mercury, lead, vanadium, and zinc). Aroclors were not measured in nest box insects due to sample mass limitations. The potential for adverse effects for inorganic chemical COPECs based on insect data can be compared with that predicted based on earthworm data. The insect samples reflect actual exposure to birds from an area near each nest box. The earthworm data reflect the contaminants and potential for exposure from a single point in the reach. Cadmium, copper, lead, vanadium, and zinc were measured in both insects and earthworms. The conclusion for cadmium is similar for both food pathways and the magnitude of the HQs are also similar; HQs for cadmium were greater than 1 at one reach based on insects and earthworms. However, the conclusions for lead and zinc differed; HQs based on concentrations in earthworms were less than 1, and HQs based on insects were greater than 1. The maximum HQ for copper and vanadium based on the earthworm data is much less than the maximum HQs based on the insect data; the HQs for both pathways are greater than 1.

The exposure evaluation for the robin also identifies reaches where COPECs have HQs greater than 1. There were six reaches (AEN-1, AW-1, PA-1E, THM-1, TW-1E, TWN-1E) where the HQs for the earthworm pathway were greater than 1 for one or more COPECs. HQs greater than 1 were observed for all reaches where insects were sampled (AW-1, PAS-1E, PA-2W, PA-3E, TWSE-1W). The magnitude for the lead and zinc HQs based on insects from reach AW-1 is larger than the HQs for these COPECs measured in other reaches.

8.1.3.4 Mammalian Invertevore Feeding Guild

The representative receptors for the mammalian invertevore feeding guild are the deer mouse and shrew; all deer mouse COPECs were also shrew COPECs. Therefore, this section estimates the potential dose to shrews using the concentrations in the insects collected from the nest boxes or concentrations in worms from the earthworm bioaccumulation bioassay. The equation for calculating HQs was presented in Section 8.1.3.2, and exposure parameters for the shrew are from the SLERA document (LANL 2004, 087630, p. 38) and are listed in Appendix E-1.0.

COPECs for the shrew were identified in the approved biota investigation work plan (LANL 2006, 093553, p. D-4) and the Phase 2 summary report (LANL 2007, 095408, p. 5). Antimony, cadmium, perchlorate, thallium, Aroclor-1248, and 2,3,7,8-TCDD met the criterion for study design COPECs (HQ >3). Perchlorate was also identified as a COPEC because there is no mammalian TRV for this COPEC; this COPEC is evaluated in a qualitative manner in the uncertainty analysis (Section 8.1.4.2). Note that 2,3,7,8-TCDD was not measured in shrew food and is evaluated in a qualitative manner in the uncertainty analysis (Section 8.1.4.2). The TRVs used for the shrew are summarized in Appendix E-1.0.

Table 8.1-10 shows the calculated HQs for the shrew based on exposure to concentrations measured in nest box insects or earthworms. In all cases, there is a single sample result for insects or earthworms in each reach. Table 8.1-10 displays all results for the food pathway if the HQ for a COPEC in any reach was greater than 1; otherwise, the results for the reach with the largest HQ is presented and the results for reach AW-1 are presented. Reach AW-1 has the largest HQ for many COPECs.

The HQs for insect or earthworm ingestion pathway are shown in Table 8.1-10 and predict a potential for adverse ecological effect based on HQs for four COPECs exceeding 1 (Aroclor-1248, antimony, cadmium, and thallium). The potential for adverse effects based on insect data can be compared with that predicted based on earthworm data. The insect samples reflect actual exposure from an area near each nest box.

The earthworm data reflect the contaminants and potential for exposure from a single point in the reach. Antimony, cadmium, and thallium were measured in both insects and earthworms. The conclusion for cadmium is similar for both food pathways and the magnitude of the HQs is also similar; HQs for cadmium were greater than 1 at one reach based on insects and earthworms. However, the conclusion for antimony differed; HQs based on concentrations in earthworms were less than 1, and HQs based on insects were greater than 1. The maximum HQ for thallium based on the earthworm data is much less than the maximum HQs based on the insect data; the HQs for both pathways are greater than 1. Aroclors were measured in earthworms but not in insects due to sample mass limitations; Aroclor-1248 was detected in one earthworm sample and the HQ in that reach was 21 (Table 8.1-10).

The exposure evaluation for the shrew also identifies reaches where COPECs have HQs greater than 1. There were seven reaches (AEN-1, AW-1, PA-0, PA-1E, PA-4, TW-1E, and TWN-1E) where the HQ for the earthworm pathway was greater than 1 for one or more COPECs. HQs greater than 1 were observed for four of the five reaches where insects were sampled (AW-1, PAS-1E, PA-3E, and TWSE-1W). The magnitude of the antimony HQ based on insects from reach AW-1 is larger than the HQs for these COPECs measured in other reaches.

8.1.3.5 Detritivores

COPECs for detritivores were identified in the approved biota investigation work plan (LANL 2006, 093553, p. D-4) and the Phase 2 summary report (LANL 2007, 095408, p. 5). Chromium, copper, and mercury met the criterion for study design COPECs (HQ >3). The potential for adverse ecological effects from these COPECs was evaluated by measuring growth and survival of earthworms at 10 locations in the Pajarito watershed in comparison with one reference location (reach PA-0). There was a single replicate of these samples in the Pajarito watershed; the Pajarito watershed results were compared with the replicate earthworm bioassay results from the Los Alamos, Pueblo, and Mortandad watersheds (LANL 2004, 087390; LANL 2006, 094161) for a more comprehensive assessment. Reference site earthworm toxicity tests from the Los Alamos, Pueblo, and Mortandad watershed studies were also included in the statistical analyses.

The results for the earthworm bioaccumulation test are summarized with box plots for survival and growth (as weight change) in Figures 8.1-7 and 8.1-8. The boxes on these plots indicate the interquartile range of the sample results, with the upper and lower ends defined by the 75th and 25th percentiles, respectively. Horizontal lines within the boxes indicate median values, and lines above and below the boxes represent the 5th and 95th percentiles of the data. Dunnett's *t*-test results are presented in the right-hand section of each figure. The comparison circles indicate statistical differences between the tests and the reference sites. The reference site sample for the Dunnett's *t*-test is displayed as a heavy red circle, and the text for the reference site is printed in bold red text on the x-axis. Thin red circles represent samples that are not statistically different ($p < 0.05$), and the watershed names are displayed in red on the axis. Heavy gray circles represent samples that are statistically different, and these names are printed in black on the x axis. No significant differences in survival were seen between any of the watersheds and the reference locations; survival was greater than 80% in most samples. In all treatments, earthworms showed weight loss, which is typical of earthworms in this assay (EP&T 2005, 091267). There were no significant differences in weight change relative to reference sites.

The sediment samples were also analyzed for COPECs; the concentrations of earthworm study design COPECs did not correlate to differences in survival or weight loss. Organic matter in soil can serve as a food source for earthworms during this type of test. Organic matter was measured in each of these samples; the organic matter in the sample did correlate with the percent survival but did not correlate with weight change in the test groups. Analyses of earthworm survival and growth with COPECs and confounding factors are presented in Appendix E-1.0.

8.1.3.6 Plant (Primary Producers)

COPECs for plants were identified in the approved biota investigation work plan (LANL 2006, 093553, p. D-4) and the Phase 2 summary report (LANL 2007, 095408, p. 5). Antimony, barium, chromium, copper, manganese, selenium, silver, thallium, vanadium, and zinc met the criterion for study design COPECs (HQ>3). The potential for adverse ecological effects from these COPECs was evaluated by measuring germination and growth of ryegrass at 10 locations in the Pajarito watershed in comparison with one reference location (reach PA-0). There were five replicates for each location.

A number of measures of plant growth and survival are included in the laboratory toxicity test on samples collected from the Pajarito watershed; these measures include mass of wet shoots, mass of wet roots, and percent germination (survival). The results are plotted on box plots with the results of the Dunnett's *t*-test comparison is printed on the right-hand side of the figure; this type of figure is explained in Section 8.1.3.5. As shown in Figure 8.1-9, the mass of shoots showed no significant differences between the reaches and the reference location. In the analysis of root mass shown in Figure 8.1-10, the plants grown in soil from reach TWN-1E had significantly greater mass of roots compared with the other reaches, and plants grown in soil from reach TW-1W had significantly less mass of roots compared with the other reaches. Reach TW-1W was selected as an upstream comparison location to evaluate TCDD concentrations; reach TW-1W, in addition to reach PA-0, represents reference conditions in the Pajarito watershed. Survival of plants did not differ from the reference location (Figure 8.1-11).

The sediment samples were also analyzed for COPECs; the concentrations of plant study design COPECs did not correlate to differences in survival or weight. Organic matter, nutrients, or particle size can be confounding factors for seedling germination tests; confounding factors did not correlate with the percent survival or weight change in the test groups. Analyses of plant survival and growth with COPECs and confounding factors are presented in Appendix E-1.0.

8.1.3.7 Aquatic Community

COPECs for aquatic community were identified in the approved biota investigation work plan (LANL 2006, 093553, p. D-6) and the Phase 2 summary report (LANL 2007, 095408, p. 5). Barium, cyanide, iron, manganese, silver, anthracene, Aroclor-1254, Aroclor-1260, benzoic acid, and DDT[4,4'-] met the criterion for study design COPECs (HQ >3). The potential for adverse ecological effects from these COPECs was evaluated with the *Chironomus tentans* toxicity test and the information obtained from the rapid bioassessment protocol.

***Chironomus tentans* Toxicity Bioassay**

The *Chironomus tentans* toxicity test measures survival and growth of larval insects in active channel sediment collected from the five reaches specified in Table 8.1-2. There were eight replicates per test for each location. Figure 8.1-12 shows box plots of larval survival for each replicate at the conclusion of the test. This box plot shows that reach PAS-2E had significantly greater survival than the reference site (PA-0) and reach PA-4 had significantly less survival than the reference site. Figure 8.1-13 shows that reaches PAS-2E, TW-2E, and PA-4 had significantly less larval growth than the reference site. Thus, there are statistically significant differences in both survival and growth for chironomid bioassays in the Pajarito watershed.

Additional comparisons were performed based on the average chironomid survival and growth for bioassays completed in the Los Alamos and Pueblo, Mortandad, and Pajarito watersheds, and reference locations. The chironomid bioassay test procedure allows for second or third instar larvae be used in the test; these animals vary in size. To make different test batches comparable, the growth numbers were

divided by the average laboratory control growth. Figure 8.1-14 presents the mean chironomid survival, and Figure 8.1-15 presents the mean normalized larval growth. Mean survival was 80% or greater for all but two sample locations. Normalized larval growth was generally around 1 (or equal to the laboratory control). There are three samples with higher than control growth—two of the samples were collected in reach PA-0 and the other was collected in reach AW-1.

The EPA chironomid test protocol (2000, 073776) recommended testing for a variety of physical measurements because survival and growth can be influenced by such confounding factors. Some of the sediment size measures did correlate with particle size measures. Figure 8.1-16 shows the most significant relationship, which was between normalized larval growth and the amount of silt-sized material in the sample. The sediment samples were also analyzed for COPECs; the concentrations of aquatic community study design COPECs did not correlate to differences in survival or growth. Further analyses of chironomid survival and growth with COPECs and confounding factors are presented in Appendix E-1.0.

Rapid Bioassessment Characterization

Data on collected macroinvertebrates, habitat scores, and dissolved oxygen levels in reaches PAS-2E and TW-2E indicate that these sites are suboptimal for sustaining a diverse community of aquatic life (Henne 2008, 102991). However, the assessment protocols used are based on perennial streams and may be biased toward rating ephemeral streams, like the stream present in reach TW-2E, as degraded. Reach PA-4 is a wetland and the protocols are not applicable to this kind of aquatic environment. Hess sampling was implemented at reach PAS-2E and this site was comparable to reference conditions for New Mexico streams. Hess sampling was not implemented at reaches TW-2E and PA-4 based on low flow or habitat conditions, so quantitative estimates are not available for comparison to the NMED metric. Reach PA-4 is a wetland with pools and multiple channels; tadpoles were present and filamentous algae covers about 70% of the streambed and there were also abundant clumps of floating algae. Reach PAS-2E has a slight amount of algae on some of the rock. Reach TW-2E has a stream channel with very low flow and some pools. Reach AW-1, which had no flow during the assessment period, was not sampled and provided poor habitat for aquatic species.

Macroinvertebrates were collected from reaches TW-2E and PA-4 by D-frame dip net and from PAS-2E using the Hess sampler. Chironomids dominated the individuals identified from reach TW-2E and were also collected from reaches PAS-2E and PA-4. Table 8.1-11 provides the habitat assessment scores by parameter for each reach. Data on macroinvertebrate sample abundance and number of taxa are provided in Table 8.1-12. The predominance of chironomids at the sites supports the use of the *Chironomus tentans* laboratory toxicity test as the appropriate assay to determine if sediment COPECs are adversely impacting the macroinvertebrate communities in these ephemeral stream systems.

8.1.4 Risk Characterization

ERAGS Step 7 is risk characterization, which includes risk estimation and the uncertainty analysis. Risk estimation includes a summary of the results for the measures used to evaluate potential for ecological effects. A qualitative weight of evidence (WOE) criterion was assigned to each measure in Appendix D of the approved biota investigation work plan (LANL 2006, 093553). If measures indicate different outcomes, meaning one measure indicates a potential for adverse effects and one does not, then the overall conclusion is weighted toward the measure with the higher WOE.

8.1.4.1 Risk Estimation

Mexican Spotted Owl

The two main measures for the Mexican spotted owl are the ECORSK.9 modeling and the modeling of estimated dose through the food chain from the study design COPECs detected in small mammals. The WOE assigned to each measure is shown in Table 8.1-13. In the ECORSK.9 model, the total adjusted mean HI (using zero for nondetects) across the core and buffer areas for the owl was 0.1. This value is less than the HI target of 1.0, indicating that there are no adverse effects on individual owls from COPECs considered in the model. No Mexican spotted owls currently nest in the Pajarito watershed. The other measure estimated the dose to the Mexican spotted owl based on concentrations in their food (Section 8.1.3.1). Small mammals were not trapped and analyzed for COPECs because the concentrations in sediment in other canyons were higher than those measured in the Pajarito watershed. Measured concentrations of PCBs and mercury in small mammal tissue collected in the Los Alamos, Pueblo, and Mortandad watersheds (LANL 2004, 087390; LANL 2006, 094161) were not associated with the potential for adverse effects on the Mexican spotted owl. Based on the measurements of COPECs in small mammal tissue and the ECORSK.9 model results, the WOE indicates no adverse effects of COPECs on survival and reproduction of the Mexican spotted owl (AE1).

Aerial Insectivore Feeding Guild

The aerial insectivores applicable measures for the southwestern willow flycatcher are the ECORSK.9 model, the results of estimated dose through prey using the COPEC concentrations detected in nest box insects and earthworms, and the field nest box measures. The WOE assigned to each measure is presented in Table 8.1-14. The ECORSK.9 model had a total mean-adjusted HI of 2.3, indicating some potential for risk to the flycatcher through exposure to cadmium, vanadium, Aroclor-1254, copper, lead, and cyanide, as presented in Section 8.1.3.2 and Gonzales et al. (2008, 102790). The exposure evaluation calculated HQ values >1 for PCB mixtures and four metals based on the concentration in earthworms or insects. These calculations indicate potential for risk to flycatchers from ingestion of invertebrates, but the locations where HQs are greater than 1 are not in southwestern willow flycatcher habitat. The spatial extent of elevated concentrations of PCBs mixtures and three inorganic COPECs (vanadium, lead, and cyanide) in sediment does not extend into reach PA-4 (Section 7.1, Table 7.1-1), which is the part of the Pajarito watershed with habitat for the southwestern willow flycatcher. Concentrations of cadmium and copper are greater than background in reach PA-4 and thus represent potential for adverse effects, but the HQs calculated using the ECORSK.9 model for these inorganic chemical COPECs are less than 1. The WOE from these measures indicates some potential for adverse effects on survival and reproduction of the southwestern willow flycatcher (AE6) from COPECs in sediment. However, the field measures (nest box studies) of other avian insectivores do not show impacts to nest success, which indicate that the models used for assessing the flycatcher overestimate the potential for ecological risk to avian insectivores. In addition, the southwestern willow flycatcher has not been observed in this part of the Laboratory, so the risk to this species is hypothetical at this time.

The potential for risk to the occult little brown myotis bat is evaluated based on exposure to COPECs in their food. There was potential for adverse effects from Aroclor-1248 and cadmium, if all insects come from specific Pajarito watershed reaches. Aroclor-1248 was not detected frequently in sediment and earthworm samples; Aroclor-1248 was not measured in nest box insects. The HQs for cadmium were generally less than 1, which indicates no potential for adverse effects to the bat for most of the Pajarito watershed. The potential for adverse effects of COPECs on bat survival and reproductions is unlikely when accounting for the large home range for the bat.

Avian Ground Invertevore Feeding Guild

A number of measures were evaluated for the avian ground invertevore feeding guild. The WOE assigned to each measure is provided in Table 8.1-15. An exposure evaluation to COPECs in diet was also done; this analysis evaluated COPEC concentrations in the earthworms and nest box insects. The dose modeling indicates a potential for adverse effects on avian ground invertevovores through ingestion of COPECs in food. The following COPECs had $HQ > 1$: Aroclor-1248, Aroclor-1254, cadmium, copper, mercury, lead, vanadium, and zinc. The measured exposures to PCBs mixtures and metals are greater than the bioaccumulation factors used in the ESLs; this greater potential for bioaccumulation leads to predictions of the potential for adverse effects in some reaches (e.g., AW-1, TW-1E). A number of field measures of impacts on avian invertevore species were also conducted. The measures of nest success through percent fledged, percent female nestlings, and egg size and thickness show no differences between the Pajarito watershed and reference locations. Because the avian monitoring network was expanded in 2007, there are two field seasons of information on nest success and limited information on exposures. There are no eggs analyzed from the expanded avian monitoring network in the Pajarito watershed and no analyses of PCB mixtures for nest box insects. Overall, the WOE indicates that COPECs in the Pajarito watershed reaches do not pose a risk to population abundance or persistence and species diversity of avian ground invertevore feeding guild species (AE2).

Mammalian Invertevore and Omnivore Feeding Guild

The mammalian invertevore and omnivore feeding guild includes both the deer mouse (an omnivore) and the shrew (an insectivore). Two lines of evidence were evaluated for these species, and the WOE for these lines is presented in Table 8.1-16. One measure for the small mammals was to estimate the potential dose to them through ingestion of earthworms or nest box insects. Both the shrew and deer mouse are modeled for the ESL development with invertebrates in their diet, but as explained in Section 8.1.3.4, the exposure evaluation was conducted using the shrew. Aroclor-1248, antimony, cadmium, and thallium had an $HQ > 1$ for the shrew, which indicates a potential for adverse effects on mammals from these COPECs. Aroclor-1248 was detected only in a single earthworm sample and thus does not suggest the potential for adverse effects on shrew populations. The HQ for antimony was equal to 1.0 and thus exposure was roughly equal to the no effect level. Cadmium had $HQs > 3$ in two locations, which is not likely to be associated with the potential for adverse effects on shrew populations in the Pajarito watershed. Thallium had an $HQ > 3$ for shrews in a single location and the spatial extent of thallium contamination in sediments is limited to the North Anchor East basin (Section 7.1, Table 7.1-1); adverse effects on shrew populations in the Pajarito watershed are not likely. Overall, the WOE for small animals indicates that COPECs in soil do not have adverse effects on population abundance or persistence and diversity of mammalian invertevore and omnivore feeding guild species (AE3).

Detritivores

A laboratory toxicity test measured both survival and weight change in earthworms from samples in reaches with and without soil COPECs (Section 8.1.3.5). The WOE for this measure and measures of detritivores relevant to other receptors is given in Table 8.1-17. There was no difference in survival between any of the reaches. There were differences in weight loss between the reaches, but the differences in weight loss did not correlate with COPEC concentrations. The WOE for detritivores indicates that COPECs in soil in the Pajarito watershed reaches do not adversely impact survival and growth of detritivore species (AE4).

Plants (Primary Producers)

Lines of evidence and their WOE for plants are provided in Table 8.1-18. The main line of evidence is the seedling germination test. Survival and most measures of growth in roots and shoots showed no difference between reaches and reference sites (Section 8.1.3.6). One measure (root weight) differed significantly between reaches but did not correlate with COPEC concentrations. The overall WOE indicates no adverse effects of COPECs in soil on native plant species presence and diversity (AE5).

Aquatic Community

Table 8.1-19 provides the measures used as lines of evidence for evaluating potential impacts to the aquatic community in the Pajarito watershed, and the WOE assigned to each measure. The laboratory toxicity test using *C. tentans* showed no difference in survival and no difference in growth correlated with COPEC concentration. The field bioassessment characterization indicated that chironomids dominate the aquatic community in one of the sampled reaches and that the toxicity test using chironomids is an appropriate measure of impacts to the aquatic community. The WOE for measures of the aquatic community indicates there are no adverse effects from COPECs in sediment and water on abundance and survival of the aquatic community in the reaches of the Pajarito watershed (AE7).

8.1.4.2 Uncertainty Analysis

Exposure Uncertainty

Uncertainties in the ecological risk assessment are potentially associated with the characterization of sediment. Maximum detected concentrations were used for some comparisons, which would overestimate the exposure concentration in a reach. For the ECORSK.9 model, arithmetic mean concentrations in soil in each grid cell were used; because sampling is biased toward locations where contaminant concentrations are highest, use of straight means generally provides overestimates of actual exposure concentrations. Media concentrations for evaluating the results of laboratory toxicity tests came from the discrete sediment samples used in those tests and provide a good estimate of the exposure concentration for the assay organisms. These concentrations would overestimate exposure concentrations throughout the sampled reaches because sampling was biased to specific locations with higher concentrations of COPECs in these reaches.

For the laboratory analyses of biological tissues, there was insufficient sample mass for analysis of all study design COPECs. For example, PCB mixtures were not measured in nest box insects and mercury was not measured in eggs. In other cases the COPECs are not detected (e.g., PCB mixtures in invertebrates), but the detection limits result in HQ values greater than 1. Cyanide and phthalate esters [bis(2-ethylhexyl)phthalate, di-n-butyl phthalate] were not measured in tissues, but these COPECs have very limited spatial extent in sediments (Section 7.1, Table 7.1-1). Their omission does not represent a significant uncertainty for this assessment.

Measured COPEC concentrations in earthworms provide a comparison to the uptake of COPECs predicted by the TFs used to develop ESLs. The measured COPEC concentrations were used in the exposure evaluation, and in some cases the measured uptake was greater than that assumed for the ESLs. Thus, the assumptions made to identify COPECs and receptors are generally protective, but there is potential for underestimating risk in some cases. Basing the conclusions for the ecological risk assessment helps to mitigate uncertainties and cases where the risks can be underestimated.

Another uncertainty is the adequacy of the toxicity and bioaccumulation data used to develop the assessment endpoints and select the associated measures and develop the study design. Toxicity

information is lacking for some classes of COPECs on some receptors that hamper evaluating those COPEC-receptor combinations except in the field studies. Perchlorate is one COPEC that lacks TRVs for any terrestrial receptor, but the spatial distribution of perchlorate in sediments does not suggest a Laboratory source in the Pajarito watershed (Section 7.1, Table 7.1-1). The study design included field, laboratory, and model components to provide complementary information and reduce uncertainties related to toxicity and bioaccumulation data.

Field Measures

Empirical ecological effects data are the most relevant data for determining if there are adverse effects on ecological receptors, especially at the population level. However, these data are inherently more variable and difficult to quantify than laboratory measures. Uncertainty associated with a limited number of locations and a limited number of sampling events is mitigated by collecting information across a variety of measures of exposure and effect. Factors unrelated to COPECs, such as drought and other climatic variations, fire, and annual variation in species, can have confounding effects on analysis of field measures.

The avian nest box monitoring network provides the field measures implemented for this ecological risk assessment. The network was expanded in 2007 to encompass areas of the Pajarito watershed. Thus, there are limited field measures based on two field seasons.

Field measures can also provide some information on adverse effects that cannot be obtained with other methods. This includes an estimate of impacts from COPECs for which there are no toxicity values. Field measures also provide valuable information on the usefulness of models and transfer factors in predicting ecological effects.

Laboratory Measures

Laboratory toxicity tests provide more standardized results than field data because they are conducted under controlled conditions, but they are still subject to uncertainties associated with sample collection and representativeness. Confounding factors are also possible, as was demonstrated in this investigation by the effect of particle on the results of the chironomid toxicity test (Section 8.1.3.7). Other confounding factors may include variability in the test species selected; for example, the size of chironomid larvae vary between the various batches of bioassays. Pajarito watershed soil and sediment are generally nutrient poor, which can influence growth in plant, earthworm, and chironomid tests. Sample sites were also selected to represent a gradient of COPEC concentrations to improve the representativeness of the toxicity tests.

Model Measures

ECORSK.9 represents a modified exposure model with many of the limitations of the simple exposure models used in screening-level ecological risk assessments. ECORSK.9 blends more realistic information on spatial use of the watershed with simple models of contaminant bioaccumulation and toxicity (Gonzales et al. 2008, 102790). In ECORSK.9, conservatism is still present for key parameters like TRVs and bioaccumulation factors. For example, the TRVs are based on NOAELs or the geometric mean of NOAEL values, and risks are assessed assuming additivity of response or summing of exposure across COPECs. ECORSK.9 is also based on conservative estimates of COPEC concentrations in soil; it assumes that the average of the sample data for a model grid cell is representative of the true concentration, although sampling is typically biased toward areas with higher concentrations of contaminants. For this study, nondetected organic chemical results were handled as either one-half their

detection limits or as zero. The different results demonstrate that assumptions regarding nondetects can obscure sources of problem contaminants and overestimate risks. The simple dose modeling from concentrations in food done for this investigation is subject to many of the same uncertainties arising from toxicity values, transfer factors, and assumptions about concentrations and nondetects as the ECORSK.9 modeling.

8.1.5 Summary

Many COPECs were identified as study design COPECs in the ecological screening of soil, sediment, and surface water in the Pajarito watershed. The WOE demonstrated by the various lines of evidence for the seven assessment endpoints indicates there are no adverse effects of COPECs on terrestrial and aquatic receptors in the Pajarito watershed. The overall WOE from field studies, analysis of COPEC concentrations in tissues, and laboratory toxicity tests supports this conclusion. Thus, no COPECs are retained for any further assessment or mitigation as a result of this baseline ecological risk assessment. The avian nest monitoring and assessment of aquatic invertebrate populations provided direct measures of exposure end effect in the Pajarito watershed. Monitoring of biological populations should continue and these results should be included in future reports as appropriate.

8.2 Human Health Risk Assessment

This human health risk assessment evaluates the potential for adverse effect on human health in the Pajarito watershed for COPCs identified in Section 6 of this report. The risk assessment approach used in this report follows guidance from EPA (1989, 008021), the Laboratory (2004, 087800), NMED (2006, 092513), and EPA (2005, 091002) and is organized in seven major subsections. The approach utilizes media- and scenario-specific media-based screening levels to evaluate the potential for human health risks from sediment and surface water in the Pajarito watershed. Section 8.2.1 provides the basis for selecting exposure scenarios for the human health risk assessment. In Section 8.2.2, the data collection and evaluation processes described in previous sections of the report are summarized, focusing on aspects of data analysis that are pertinent to the risk assessment. Section 8.2.2 also lays out the logic for selecting COPCs for the human health risk assessment. The exposure assessment (Section 8.2.3) provides information used in quantifying human exposure to COPCs in sediments and water. The toxicity assessment (Section 8.2.4) provides information on potential human health effects from chemicals and radionuclides evaluated in the risk assessment. Section 8.2.4 provides the sources for the media- and scenario-specific screening levels. Risk characterization (Section 8.2.5) is based on the sum of fractions (SOF) method for evaluating the potential for additive effects with COPCs that are classified as noncarcinogens, carcinogens, or radionuclides. Uncertainty related to the various assumptions and inputs used in the risk assessment is evaluated in Section 8.2.6 to support interpretation of the risk characterization. A summary of the risk assessment is provided in Section 8.2.7.

8.2.1 Problem Formulation

The purpose of this risk assessment is to evaluate potential human health risks related to the COPCs identified in sediments and surface water in the Pajarito watershed. This information can be used to inform a risk management decision. This risk assessment uses information pertaining to current and reasonably foreseeable future land use to assess potential impacts under reasonable maximum exposure (RME) conditions. The canyon bottoms in the Pajarito watershed include a mixture of Laboratory property and public and private lands, potentially supporting a variety of land-use alternatives.

The assessment in this report primarily employs the trail user exposure scenario to represent the current and reasonably foreseeable future exposure activities for contaminated sediments and surface waters in

the watershed. The trail user scenario describes an adult individual who contacts contaminated sediments and surface water while hiking or jogging in the canyons. This use is considered to be inclusive of realistic present-day potential exposure activities in canyon bottoms in areas of the watershed where contaminants are at levels requiring a human health risk assessment. Because of restricted access and the steepness of most parts of the canyon, a child recreational exposure scenario was not considered applicable.

One supplemental exposure scenario, residential, is evaluated in the human health risk assessment for comparison purposes only. A description of this supplemental exposure scenario is provided in Section 8.2.3.2. Unlike the trail user scenario, residential use is not currently applicable across the watershed. A residential scenario does not represent current or reasonably foreseeable future land uses in the canyon bottoms, and residential development in particular is not a feasible land use within the parts of the canyons subject to flooding. For this reason, an extended backyard residential scenario was not considered.

8.2.2 Data Collection and Evaluation

The approach to sampling design, data collection, and characterization is described in Sections 3 and 4 and Appendix B. Sample locations, sample results, and data quality for data employed in the human health risk assessment are presented in Appendix C. Section 6 describes how sediment data within reaches were combined for the comparison of contaminant data maxima with BVs. Water data were evaluated at each surface-water sampling location.

Identifying COPCs for the Human Health Risk Assessment

COPCs for the human health risk assessment are identified based on screening level risk calculations using a residential exposure scenario based on “Los Alamos and Pueblo Canyon Investigation Report” (LANL 2004, 087390, p. E-33) and “Mortandad Canyon Investigation Report (LANL 2006, 094161, p. 126). This process is initially inclusive of all COPCs and evaluates the potential for human health risks under a protective residential scenario. This process includes calculating a ratio, which is the maximum concentration of an analyte in a specific media in a reach or at a water-sampling station divided by the media-specific risk-based screening level. This is analogous to the HQ as used in Section 8.1 for assessing potential ecological risk. An SOF is the sum of these ratios for each risk type, i.e., carcinogens (SOF_{ca}), noncarcinogens (SOF_{nc}), and radionuclides (SOF_{rad}). These are analogous to HIs calculated in Section 8.1. Ratios for all COPCs within a reach or water location are summed to calculate the SOF for the risk class of those analytes (carcinogen, noncarcinogen, or radionuclide). For all reaches or water locations with an SOF >1.0 for a risk class, all COPCs within that risk class with ratios greater than 0.1 are retained as COPCs for the site-specific risk assessment. COPCs with a ratio ≤ 0.1 based on maximum sample results are excluded because they are unlikely to significantly contribute to risk.

Sediment COPCs: The human health screening levels for nonradionuclides in sediment used in this screening assessment are the NMED residential SSLs from Revision 4 of NMED guidance (2006, 092513). For analytes for which NMED does not provide a value, the residential screening value from EPA Region 6 (2005, 091002) or EPA Region 9 (epa.gov/region09/waste/sfund/prg/files/04prgtable.pdf) was used as the SSL (carcinogens are adjusted to a 10^{-5} risk level to be consistent with the NMED target risk level). NMED-approved surrogate compounds were used for some COPCs that lack NMED or EPA screening levels (NMED 2003, 081172). SALs related to residential land use for radionuclides are based on the soil guidelines for unrestricted release of property (DOE Order 5400.5, “Radiation Protection of the Public and the Environment”); these values are derived using RESRAD version 6.21 as described in “Derivation and Use of Radionuclide Screening Action Levels Revision 1” (LANL 2005, 088493).

Tables 8.2-1 to 8.2-3 contain the set of human health residential SSLs and SALs used to calculate ratios; these tables also provide the SOFs for each reach for each risk class for all sediment COPCs. COPCs and reaches shaded gray are those retained for the risk assessment. Table 8.2-1 provides the results for noncarcinogens, Table 8.2-2 provides the results for carcinogens, and Table 8.2-3 provides the results for radionuclides.

Surface Water COPCs: Screening levels for surface water for organic and inorganic chemicals are the EPA Region 6 risk-based screening levels for tap water (EPA 2005, 091002). The EPA Region 6 values were supplemented by screening values from EPA Region 9, available at (epa.gov/region09/waste/sfund/prg/files/04prgtable.pdf). Radionuclide screening levels are based on a dose of 4 mrem/yr and are from the DOE DCG (DOE Order 5400.5, "Radiation Protection of the Public and the Environment").

Tables 8.2-4 to 8.2-6 contain the set of human health water-screening levels used to calculate ratios; these tables also provide the SOFs for each risk class for all surface water COPCs. COPCs and water locations shaded gray are those retained for the further assessment. Table 8.2-4 provides the results for noncarcinogens; Table 8.2-5 provides the results for carcinogens; Table 8.2-6 provides the results for radionuclides.

COPC Summary: Table 8.2-7 presents a summary of endpoints and reaches considered in the human health risk assessment for the Pajarito watershed. For each reach and endpoint combination with both sediment and water COPCs retained, a multimedia assessment is also assessed for this reach.

Calculating Exposure Point Concentrations

Sediment: The investigation approach for sediments resulted in samples associated with similar or identical geomorphic units and sediment facies within each reach. These data are combined to estimate means and 95% upper confidence limits (UCLs) on the means for COPCs retained for the human health risk assessment in each reach. If the calculated 95% UCL was less than the maximum detected value for a COCP within a reach, then the 95% UCL was used for the exposure point concentration (EPC). However, if the calculated 95% UCL on the mean was greater than the maximum detected value for a COCP within a reach, the maximum detected value was used for the EPC.

Surface Water: Water COPC concentrations are evaluated for each sampling location, unlike sediments where multiple sample locations are combined to generate a representative concentration for a reach. The only exception is for locations that are basically collocated within a few meters of each other. The approach to calculating averages and 95% UCLs for the water data follows the approach described in Section E-2.0 (Appendix E). Surface-water EPC concentrations for the trail user scenario are presented in Section 8.2.5.

Many of the data sets for combinations of COPCs and reaches or COPCs and water-sampling locations include nondetect values. The approach to estimating averages and 95% UCLs with data that include nondetects is also described in Section E-2.0 (Appendix E).

8.2.3 Exposure Assessment

The trail user scenario is the exposure scenario that applies to all reaches identified in Table 8.2-7. Additionally, potential risk associated with the residential scenario is provided as a point of comparison. The two exposure scenarios employed in the human health risk assessment have been described in other documents. The trail user scenario is the adult receptor in the recreational scenario document (LANL 2004, 087800) and the recreational scenario in the radionuclide SALs document (LANL 2005,

088493). An adult trail user is evaluated in this assessment because access to most of these reaches is limited to Laboratory workers or trespassers, and it is unlikely that young children would accompany either workers or trespassers on recreational visits to these reaches. The exceptions are reach PA-0 west of the Laboratory on Santa Fe National Forest land and reach PA-5W below White Rock on Los Alamos County land. PA-0 is upcanyon of Laboratory SWMUs and AOCs; in PA-5W, the dominant sources of COPCs are natural background, ash from the Cerro Grande burn area, or runoff from roads and other developed areas, as discussed in Section 7.2. Exposures to surface-water ingestion are evaluated based on the trail user scenario described in the “Los Alamos and Pueblo Canyon Investigation Report” (LANL 2004, 087390, p. 8-37) and “Mortandad Canyon Investigation Report (LANL 2006, 094161, p. 128), which also provides risk-based concentrations for trail user surface-water exposures (LANL 2004, 087390, p. E-317). Residential SSLs are in NMED guidance (NMED 2006, 092513), and residential SALs are in Laboratory guidance (LANL 2005, 088493).

8.2.3.1 Exposure Scenario Description

The human health risk assessment focuses on potential risks resulting from direct exposure to contaminants in sediments through ingestion, inhalation, external irradiation (radionuclides only), and dermal contact (chemicals only). The water pathways for the trail user consist of ingestion and dermal contact (chemicals only) using persistent surface-water data. Exposure to stormwater is not assessed because stormwater is transient and does not occur frequently enough to sustain chronic exposures. Exposure to groundwater is not evaluated because no groundwater in the Pajarito watershed is available for human uses under current conditions or for the reasonably foreseeable future except for water from the municipal water-supply well PM-2, which is tested regularly to ensure drinking water that meets water-quality standards. A summary of potentially complete exposure pathways, by scenario, is provided in Table 8.2-8.

Exposure scenario parameters were selected to provide an RME estimate of potential exposures. As discussed in EPA (1989, 008021), the RME estimate is generally the principal basis for evaluating potential health impacts. In general, an RME estimate of risk is at the high end of a risk distribution, i.e., 90th–99.9th percentiles (EPA 2001, 085534). An RME scenario assesses risk to individuals whose behavioral characteristics may result in much higher potential exposure than seen in the average individual.

The trail user scenario addresses limited site use for outdoor activities, such as hiking and jogging. The receptor for this scenario is anticipated to be a Laboratory employee using the canyon over an extended period of time. Therefore, receptors for the trail user scenario are defined as adults. A complete description of the parameter values and associated rationale is provided in Laboratory guidance (LANL 2004, 087390, p. 8-37). Exposure parameters for the trail user are provided in Appendix E-2.0.

8.2.3.2 Supplemental Exposure Scenario

Risk estimates are provided for a resident as a supplemental exposure scenario. A more detailed discussion of the basis and parameterization of this scenario is provided in NMED guidance (2006, 092513) and Laboratory guidance (2005, 088493). Exposure parameters for the resident are provided in Appendix E-2.0.

8.2.3.3 Spatial Scales of Application for the Exposure Scenarios

Each exposure scenario is evaluated at the scale of a reach for sediments and at the scale of individual sampling locations for water. Each of the surface-water sampling locations has been associated with a reach for combining results into a multimedia assessment (where appropriate). The investigations evaluated in this report have multiple investigation reaches and water-sampling locations. The risk assessment does not attempt to integrate exposure across multiple reaches for sediment or across water sampling locations for surface water. By assessing each reach and associated water-sampling locations separately, the impacts of local variability in COPC concentrations upon the risk assessment results are preserved.

8.2.4 Toxicity Assessment

This section of the human health risk assessment provides information related to the basis for distinguishing among the three classes of chemicals that are evaluated in this assessment: systemic toxicants (noncarcinogens), chemical carcinogens, and radionuclides. This information provides a context for interpreting the results of the risk assessment, which employs COPC-specific values of toxicity and radiation dose to evaluate potential health impacts.

Using media-specific risk-based screening levels simplifies aspects of the risk assessment in that exposure and toxicity information has been compiled in available guidance documents and reports. The sources for toxicity data used for this risk assessment include NMED and Laboratory guidance documents and the "Los Alamos and Pueblo Canyon Investigation Report" (LANL 2004, 087390) and its supplement (LANL 2005, 091818). The "Los Alamos and Pueblo Canyon Investigation Report" is used as a source of surface-water screening values because there is no guidance document available with such values, and the exposure information provided therein is germane to trail user exposures in other Laboratory canyons. Toxicity information used to develop surface-water screening values is also generally consistent with values used in NMED and Laboratory guidance documents (as discussed below).

Media-specific risk-based screening levels are from seven sources based on COPC type and exposure medium.

- Recreational scenario (trail user) for carcinogens and noncarcinogens
 - ❖ Sediment: used the recreational SSLs developed in Laboratory guidance (LANL 2004, 087800)
 - ❖ Surface water: used the risk-based concentrations for trail user surface-water ingestion and dermal contact developed in the "Los Alamos and Pueblo Canyon Investigation Report" (LANL 2004, 087390, except lead is from ; LANL 2005, 091818)
- Recreational scenario (trail user) for radionuclides
 - ❖ Sediment: used the recreational SALs developed in Laboratory guidance (LANL 2005, 088493)
 - ❖ Surface water: used the risk-based concentrations for trail user surface water ingestion developed in the "Los Alamos and Pueblo Canyon Investigation Report" (LANL 2004, 087390)

- Residential scenario for carcinogens and noncarcinogens
 - ❖ Sediment: used the SSLs from NMED guidance (2006, 092513), except for certain values from EPA Region 6 (2007, 099314) and EPA Region 9 (epa.gov/region09/waste/sfund/prg/files/04prgtable.pdf)
- Residential scenario for radionuclides
 - ❖ Sediment: used the residential SALs developed in Laboratory guidance (LANL 2005, 088493)

Table 8.2-9 provides the compilation of the sediment and surface-water media-specific risk-based screening levels and target adverse effect levels. Comparing the screening values with COPCs for a given risk endpoint provides some information of the relative toxicity of these analytes. Because these risk-based screening values are obtained from references prepared from 2004 to 2006, there is potential for differences in the toxicity values used in the screening level calculations. The slope factors and reference doses were compared with the COPCs listed in Table 8.2-9 among the sources; differences in these toxicity values are summarized in Table 8.2-10. This information will be considered in the uncertainty analysis of this assessment.

8.2.5 Risk Characterization

In this section of the human health risk assessment, information provided in the exposure and toxicity assessments (Sections 8.2.3 and 8.2.4, respectively) is integrated to characterize potential adverse effects. The risk characterization is conducted on the basis of the general principles described in Section 8.0 of the risk assessment guidance for Superfund (EPA 1989, 008021). Potential adverse effects related to noncarcinogens, chemical carcinogens, and radionuclides are discussed in Sections 8.2.5.1, 8.2.5.2, and 8.2.5.3, respectively. The presentation of potential adverse effects focuses on the quantitative expressions of potential impacts. In the uncertainty analysis (Section 8.2.6), the confidence associated with the quantitative risk estimates is discussed through an evaluation of the uncertainties pertaining to each step of the risk assessment process.

This risk assessment employs media-specific risk-based screening levels to evaluate COPCs for potential adverse health effects. COPC intake and toxicity are combined within the screening value calculations; therefore, separate calculations of intake and health effects (cancer risk, hazard, and dose) were not generated. Human health effects were assessed using the ratios of representative concentrations to media-specific risk-based screening levels for each COPC retained in this assessment for each of the exposure scenarios. These ratios were summed for an investigation reach and (when applicable) a water-sampling location within the COPC classes of chemical carcinogens, noncarcinogens, and radionuclides (SOFs). A sum of less than 1 indicates that exposure is unlikely to result in an unacceptable cancer risk, hazard, or radiation dose. The SOF values were multiplied by the target effect level (i.e., $HI = 1$, $risk = 1 \times 10^{-5}$, or $dose = 15 \text{ mrem/yr}$) to provide risk estimates for each COPC class.

For the trail user scenario, exposure to sediment and surface water is evaluated through a multimedia sum. For COPCs with a common target adverse effect level (e.g., all carcinogens are based on 1×10^{-5} incremental cancer risk), the multimedia sum can be converted into an approximate effect level. Carcinogen and noncarcinogen screening levels are based on a common adverse effect level across sediment and surface water, but the radionuclide adverse effect levels are not the same for sediment (15 mrem/yr) and surface water (4 mrem/yr).

The trail user scenario multimedia sums and the risk values for noncarcinogens, carcinogens, and radionuclides based on 95% UCLs are summarized in Table 8.2-10. Most of the carcinogen and noncarcinogenic multimedia sums are similar to the sediment risk values, which indicate that there is greater potential for effects from the sediment concentrations and exposure pathways than from surface water. None of the reaches were evaluated for multimedia exposure to radionuclides (Table 8.2-10). There is one reach where the sediment risk value is greater than the target risk level for the trail user scenario: reach TWN-1E. However, as explained in Section 8.2.5.2 this is because of anomalous results in one sediment sample from this reach.

Table 8.2-11 presents the COPC and reach-specific recreational risk values for sediment; Table 8.2-12 presents the COPC and reach-specific recreational risk values for surface water. The EPCs for sediment are presented in Table 8.2-13; the EPCs for surface water are presented in Table 8.2-14. Results for the supplemental exposure scenario (residential) are provided in Tables E-2.4-2 and E-2.4-3.

8.2.5.1 Noncarcinogenic Effects

Chemical hazard for an individual chemical is commonly defined by the HQ, which is calculated as the ratio of the chemical intake to the reference dose for that chemical. An HQ greater than 1 is indicative of the potential for adverse effects; therefore, an HQ of 1 was used in the calculation of screening values for noncarcinogenic effects. When the potentially additive effects of two or more chemicals are considered, HQs may be summed to generate an HI. However, summing of chemical HQs to create an HI assumes that the target organs and mechanisms of toxicity are similar. The SOF_{nc} values in this human health risk assessment are functionally equivalent to generating an HI. The protective approach of summing these ratios does not warrant refinement because the HI values are in all cases well below 1.0.

The potential risk from noncarcinogens was evaluated in 21 investigation reaches (5 of which were evaluated for multimedia exposure) and 21 surface-water locations (9 of which were contained within one of the investigation reaches). The four largest HI values for the trail user scenario were between 0.39 and 0.61 (Table 8.2-11) due primarily to the potential for adverse effects from aluminum and iron in sediment (reaches AW-1, PA-4, PA-5W, and TH-1E; Table 8.2-12). The HI was between 0.32 and 0.36 in four other reaches (AEN-1, AES-1, PAS-1E, TWSE-1W; Table 8.2-12) with the key contributors to these noncarcinogenic sums being aluminum and iron in sediment. HIs for any of the surface water sources were at least 1 order of magnitude below the sediment values (Table 8.2-10 and 8.2-12).

8.2.5.2 Carcinogenic Effects

Cancer risk for an individual chemical is defined by the incremental cancer risk (ICR), which is calculated as the product of exposure to a single chemical and the cancer slope factor (SF) for that chemical. ICRs for each exposure route and chemical are then summed to calculate the total ICR to an individual. A target risk level of 1×10^{-5} was used in this human health risk assessment to calculate risk-based concentrations for carcinogenic effects (NMED 2006, 092513). Lifetime cancer risk is considered to be additive over time; childhood and adulthood exposures are summed to calculate the ICR.

The potential risk from carcinogens was evaluated in 18 investigation reaches (4 of which were evaluated for multimedia exposure) and 21 surface-water locations (8 of which were contained within one of the investigation reaches). The range of sediment or multimedia ICR for the trail user scenario was from 1×10^{-4} to 1×10^{-6} (Table 8.2-7). The maximum incremental lifetime cancer risk (ILCR) (1×10^{-4}) was calculated for reach TWN-1E. The primary contributors to the ICR in these reaches from sediment were arsenic and PAHs (Tables 8.2-12 and 8.2-13). Surface-water risks ranged from 2×10^{-7} to 4×10^{-7} . Risks due to contaminants in surface water made no significant contribution to risks for any of the investigation reaches.

The high risk (1×10^{-4}) in investigation reach TWN-1E is caused by high concentrations of benzo(a)anthracene and benzo(a)pyrene in a single sediment sample collected from the active stream channel in 2005. Reach TWN-1E is below large paved areas in TA03, and the 2005 sample may have included one or more asphalt fragments. In 2006, this same location, plus two additional locations from the active stream channel, was resampled and analyzed. No high PAH values were found in these three 2006 sediment samples. If the two high PAH results from 2005 are excluded from the investigation reach TWN-1E data set, and the EPC is recalculated using maximum detected values (most conservative approach) then the resulting ILCR for TWN-1E is 1×10^{-6} (see also LANL 2007, 095408, p. 4).

8.2.5.3 Radiation Dose

The radiation dose associated with the EPA dose conversion factors (DCFs) used in the human health risk assessment is the annual committed effective dose equivalent (internal) or annual effective dose equivalent (external), expressed in units of millirems per year. The target dose limit used for calculating media-specific risk-based screening levels related to soil pathways is 15 mrem/yr, which is consistent with guidance from DOE (2000, 067489). For water-based exposure pathways, media-specific risk-based screening levels were calculated using a target dose limit of 4 mrem/yr. Use of this more protective dose limit for water pathways is based on the radiation dose limit for a public drinking water supply in DOE Order 5400.5, "Radiation Protection of the Public and the Environment." Consistent with EPA guidance (1989, 008021), dose through dermal absorption is not quantified because it is probably negligible compared with the other exposure pathways.

The potential risk from radionuclides in sediment was evaluated in three reaches and one surface-water source. None of the investigation reaches had multimedia exposures calculated for the trail user. Cesium-137 and plutonium-239/240 were evaluated in investigation reach PA-0, cesium-137 and thorium-228 in reach PA-4, thorium-228, thorium-232, and uranium-238 in reach THS-1E, and radium-226 and radium-228 in Homestead Spring. Total doses were all 2 orders of magnitude below levels of concern (15 mrem/yr for sediment and 4 mrem/yr for surface water).

8.2.6 Uncertainty Analysis

The uncertainty analysis uses qualitative and semiquantitative information to evaluate the uncertainty associated with the risk, hazard, and dose estimates described in Section 8.2.5. This uncertainty analysis pertains to the results of the trail user scenario. The uncertainty analysis is organized according to the major aspects of the human health risk assessment: data collection and evaluation (Section 8.2.6.1), exposure assessment (Section 8.2.6.2), and toxicity assessment (Section 8.2.6.3).

8.2.6.1 Data Collection and Evaluation

All analytes that were identified as COPCs in Section 6 were retained for evaluation in the human health risk assessment. COPCs that were retained for calculation of representative concentrations were those that had ratios greater than 0.1 for endpoints with SOF values greater than 1 for the residential screen. Thus, the analytes retained represent an inclusive list of potential human health risk drivers.

No BVs are available for surface water. The inability to distinguish COPCs in surface water based on comparisons with background concentrations is a substantial source of uncertainty in the results of the human health risk assessment for this media. For example, concentrations of arsenic (contributes to carcinogenic risk) and iron (contributes to noncarcinogenic HI) in surface water could be associated with local background and not with releases from Laboratory SWMUs or AOCs.

The possibility of underestimating representative concentrations for investigation reaches is another potential source of uncertainty. Four approaches were used to minimize that possibility. First, the emphasis of the geomorphic characterization and sediment sampling was to identify and sample post-1942 sediment deposits, which focuses sampling on potentially contaminated areas, excluding areas not impacted by dispersion of contaminants by post-1942 floods. The process of characterizing reaches and focusing on sampling is discussed further in Section 4.1 and Section B-1.0 of Appendix B. Second, 95% UCLs on the average sediment concentrations were employed as representative concentrations to minimize the chance of underestimating representative concentrations in a reach. Third, sampling was biased to fine facies sediment deposits where concentrations are generally highest, as discussed in Section 7.1, with fewer samples collected from coarse facies sediment deposits where concentrations are generally lower. Fourth, for radionuclides, no correction was made for radioactive decay since the time of sampling, although present-day concentrations are lower than at the time of sampling for cesium-137

Uncertainty also exists for estimating representative concentrations for water-sampling locations. COPC concentrations often change with hydrologic conditions and can either increase or decrease seasonally or related to effluent discharges. The data evaluated in this assessment represent a snapshot of the current hydrological conditions and generally reflect a range of hydrologic conditions at each sampling location. As discussed in Section 7.2.1 and Appendix B, Section B-2.0, sampling occurred during a range of water-level conditions and field parameters, such as pH and dissolved oxygen. The representative concentrations calculated from these data represent the range of COPC concentrations at the sampling locations. Using the 95% UCL on the average minimizes the chance of underestimating the representative concentrations for a sampling location.

8.2.6.2 Exposure Assessment

Uncertainty pertaining to exposure parameters was addressed in the human health risk assessment by using RME estimates for several exposure parameters (see Appendix E-3.0). The use of RME assumptions, coupled with upper-bound estimates of the average concentration of COPCs in sediment, is intended to produce a protective bias in the risk calculations. The results of the risk assessment, discussed in Section 8.2.5, include a description of the key COPCs and exposure pathways associated with potential health impacts. This evaluation of uncertainty in exposure is focused on these COPCs and pathways.

Key exposure pathways for contaminated sediments across hazard, ICR, and dose for the trail user exposure scenario include dermal absorption, incidental soil ingestion, and external irradiation. A common source of protective bias in the exposure assessment for these pathways is that the entire 1-h daily exposure time defined for the trail user scenario is spent on contaminated sediment deposits within a reach. To the extent that time may be spent in other canyon areas, such as uncontaminated stream terraces, colluvial slopes, or bedrock areas during recreational activities, exposure to contaminated sediment deposits, is overestimated.

Because each reach is treated equally from an exposure perspective, no consideration is made regarding ease of access or land area available for recreation. In addition, it is implicitly assumed that all exposure for a single individual takes place in one investigation reach, rather than some random combination of some or all of the investigation reaches.

For both carcinogens and radionuclides, the exposure assessment should be evaluating incremental exposures that are greater than background. Representative concentrations are calculated that include background concentrations. For the most part, background exposures are likely negligible with the exception of some metals in sediment and surface water (e.g., arsenic) and do not lead to overestimating risk or dose.

Dermal contact with sediments and incidental soil ingestion exposure pathways each has a second exposure characteristic in addition to time spent on-site that was biased in a protective manner. The soil adherence factors that were used to define soil loading on skin for children and adults are both protectively biased. The adult adherence factor is based on a high-exposure activity (gardening) that probably would result in greater exposure than would be the case during trail use. Adult soil ingestion was assumed to be 100 mg/d, which is twice the EPA-recommended value for adults (EPA 1997, 066596).

Because external gamma radiation is the main contributor to radionuclide dose, the assessment should also be protective of child exposures because behaviors that increase child exposure through some pathways (incidental soil ingestion and dermal contact) play basically no role in external gamma dose. Exposure related to external irradiation from soil is primarily a function of time spent on-site. However, the external DCFs used in the calculation of external dose protectively assume an effectively infinite area and depth of contamination.

An important aspect of uncertainty in exposure to COPCs in surface water relates to exposure intensity. Dermal contact and surface-water ingestion were assumed to occur 20 times per year for 30 yr (trail user). There is no empirical basis for this assumption, which was developed to bound a high-end exposure condition. Potential contact by adults with surface water in the Pajarito watershed would be highly intermittent at some locations based on the limited availability of water. It is also unlikely that a Laboratory employee would be drinking surface water.

8.2.7 Summary of the Human Health Risk Assessment

The health effects associated with COPCs in the Pajarito watershed were assessed relative to a radiological dose criterion of 15 mrem/yr for sediment and 4 mrem/yr for water, a chemical cancer risk criterion of 1×10^{-5} , and a chemical hazard criterion of 1.0. The risk assessment results are below these thresholds for the trail user.

For the three reaches with radiological contaminants (PA-0, PA-4, and THS-1E) the radionuclide risks to the trail user were all less than or equal to 1×10^{-6} (Table 8.2-12). Radionuclides for the trail user were evaluated only in Homestead Spring; the radionuclide dose was only 2×10^{-7} (Table 8.2-13).

9.0 CONCLUSIONS AND RECOMMENDATIONS

The results of this investigation indicate that human health risks are acceptable for present-day and foreseeable future land uses. In addition, no adverse ecological effects were observed within terrestrial and aquatic systems in the Pajarito watershed. Therefore, corrective actions are not needed to mitigate unacceptable risks. However, additional monitoring of sediment, surface water, groundwater, and cavity-nesting birds and their food is recommended.

The site-specific human health risk assessment uses a trail-user exposure scenario to represent the present-day and reasonably foreseeable future land use in canyons throughout the Pajarito watershed. The assessment results indicate that for the trail user scenario, no areas in the Pajarito watershed have contaminant concentrations greater than levels acceptable for noncarcinogens (HI of 1), carcinogens (incremental cancer risk criterion of 1×10^{-5}), or radionuclides (target dose limit of 15 mrem/yr in sediment and 4 mrem/yr in water) in sediment or water.

Many organic and inorganic COPECs have been identified in the ecological screening assessments; subsequently, a plan for a baseline ecological risk assessment was developed. This process is based upon the eight-step EPA ERAGS (EPA 1997, 059370). The baseline ecological risk assessment evaluated evidence of ecological risks from COPECs to omnivorous mammals, insect-eating birds, plants, earthworms, aquatic invertebrates, and two T&E species: the Mexican spotted owl and the southwestern

willow flycatcher. The multiple lines of evidence did not identify adverse effects of COPECs on terrestrial or aquatic receptors that currently inhabit the watershed. Therefore, no mitigation is necessary. Biological monitoring of cavity-nesting birds and aquatic invertebrates will continue and results will be incorporated as appropriate into future reports.

Investigations of sediment, surface water, and groundwater in the Pajarito watershed indicate that inorganic, organic, and radionuclide COPCs are present in these media at concentrations above screening levels. These COPCs are derived from several sources, including Laboratory SWMUs and AOCs, runoff from developed areas, ash from the Cerro Grande burn area, and natural sources, such as noncontaminated soils, sediments, and bedrock. The risk assessments discussed above show that human health and ecological risks are acceptable under current conditions. The conceptual model indicates that these conditions for sediments are likely to stay the same or improve. Surface water and groundwater are being actively monitored to show that the risks do not change.

The spatial distribution of sediment COPCs in the Pajarito watershed indicates that contaminants have been released and are transported downcanyon from several TAs, including TA-03, TA-08, TA-09, TA-15, TA-18, TA-22, TA-40, and TA-69. Contaminants in sediment that were released from these TAs are identifiable as COPCs for varying distances downcanyon from the sources. Some are COPCs only in reaches close to the sources, whereas others remain COPCs in the farthest downcanyon reach, PA-5W below White Rock, over 16 km (10 mi) from the sources. Transport of contaminants released from TAs in upper Pajarito Canyon above the confluence with Twomile Canyon increased after the May 2000 Cerro Grande fire associated with increased magnitude and frequency of floods and erosion of post-1942 sediment deposits along the main channels. Several COPCs in upper Pajarito Canyon that are not associated with Cerro Grande ash were present only near or below the sediment BVs downcanyon from TA-18 in pre-fire sediment deposits but are present above BVs in post-fire deposits in this area. Because the magnitude and frequency of floods generated in the Cerro Grande burn area have decreased as the watershed has recovered, this post-fire transport has also decreased. However, monitoring of COPC concentrations transported in sediment should continue, particularly in fine-grained sediment deposited after large flood events that have the highest potential for erosion and downcanyon transport.

In groundwater; manganese; iron; mercury; ammonia; chloride; 1,4-dioxane; lead; arsenic; RDX; and phenol exceed regulatory standards infrequently and show no spatial distributions relative to known release sites. Nitrate, tritium, and perchlorate, the most mobile of the inorganic chemicals released in the watershed, and radionuclides are present above background levels but below regulatory standards in surface water and in alluvial, perched intermediate, and/or regional groundwaters. Elevated concentrations of nitrate, chloride, sulfate, and tritium were also reported in vadose-zone pore water collected from core samples from boreholes. Localized contamination of RDX; 1,4-dioxane; and/or chlorinated solvents occurs at several intermediate-depth wells and springs and one regional aquifer well. The spatial distribution of COPCs indicates that TA-09, TA-18, and possibly TA-16 are the main sources of mobile contaminants in the watershed. Contaminants from TA-09 and TA-18 were transported downcanyon by surface water and alluvial groundwater before infiltrating the vadose zone and migrating into deeper zones of perched intermediate and regional groundwater. Outfalls, septic systems, and surface releases that were primarily responsible for contaminants in surface water and groundwater are no longer active. Surface water and groundwater should continue to be monitored to evaluate long-term trends in contaminant concentrations. Monitoring frequency and analyte suites will be specified in annual updates to the IFGMP.

The configuration of wells in the existing monitoring network is considered sufficient to meet the groundwater-monitoring objectives for the watershed for the most part. However, more work is needed to test the assumption that water-supply wells, in particular PM-4, are adequately protected. This assumption is based on the conceptual site model that contaminated surface water does not infiltrate to

deeper groundwater in those parts of Pajarito Canyon that are upgradient of water-supply well PM-4 (e.g., between monitoring well R-17 and water-supply well PM-2). This conceptual model should be tested by collecting additional core in the upper vadose zone near well R-17 to assess whether the reported tritium values for the R-17 corehole (Appendix H) are representative or are in error (possibly the result of sample contamination at the analytical laboratory). In addition, potential infiltration in the canyon segment between well R-17 and supply well PM-2 should be further evaluated by collecting water level data for the new alluvial wells that are installed upstream of well 18-BG-1. Additional analyses of the capture zone of the water-supply wells near Pajarito Canyon are expected to constrain uncertainty regarding the influence of municipal pumping on groundwater flow directions. These analyses will utilize the spinner test that was recently performed at PM-2 (Appendix J) and the new hydrogeologic and geochemical information collected at regional monitoring-well R-40 and other new regional monitoring wells close by. In the meantime, protection of water-supply wells PM-2, PM-4, and PM-5 is ensured by continued monitoring directly in those wells.

The monitoring well network evaluation will be improved when the analytical data from the new monitoring wells and water-level data are obtained from wells R-37, R-38, R-39, R-40, and R-41, which are currently being installed at or adjacent to TA-54. After the wells are installed, the monitoring well network efficiency may be reevaluated if an updated water table map indicates a groundwater flow direction different from the previous analysis. Flow and transport models supporting the network evaluation will also benefit from an updated geologic model of the area based on observations made at the newly installed wells.

10.0 ACKNOWLEDGMENTS

The following are the primary contributors to this report.

- Project Leaders: Danny Katzman and Steven Reneau
- Risk Assessments: Randall Ryti, David Brenner, Jenifer Linville, and Wendy Swanson
- Sediment and Biota Investigations: Steven Reneau
- Surface-Water Investigation: Richard Koch and Kay Birdsell
- Springs: David Broxton
- Alluvial Groundwater Investigation: Richard Koch and Kay Birdsell
- Groundwater Geochemistry Investigation and Contaminant Distributions: Patrick Longmire, David Vaniman, and Wendy Swanson
- Flow and Transport Modeling: Velimir Vesselinov and Terry Miller
- Regional Water-Level Analysis: Velimir Vesselinov, Rich Koch, and Dylan Harp
- Geologic Setting: David Broxton and David Vaniman
- Contaminant Sources: Steven Reneau, Pat Longmire, David Vaniman, and Kay Birdsell
- Data Management and Contaminant Identification: Kelly Bennett, Warren Houghteling, Kristen Lockhart, and Wendy Swanson
- Document Preparation: Susan Rhyne, editor; Julie Marquez, compositor; and Sandra Martinez, document manager

In addition, the following individuals contributed to associated fieldwork, laboratory analysis, map preparation, and/or data analysis: Andy Crowder, Paul Drakos, Jeanne Fair, Phil Goetze, Gilbert Gonzales, Keith Greene, William Hardesty, Mary Harmon, Jeff Heikoop, Lisa Henne, Rick Kelley,

Emily Kluk, Toti Larson, Alexis Lavine, Kirby Olson, George Perkins, Michael Rearick, Winters Red Star, Kevin Reid, Jim Riesterer, Len Sabatino, Joe Toya, and Doug Walthers.

11.0 REFERENCES

The following list includes all documents cited in this report. Parenthetical information following each reference provides the author(s), publication date, and ER ID number. This information is also included in text citations. ER ID numbers are assigned by the Environmental Programs Directorate's Records Processing Facility (RPF) and are used to locate the document at the RPF and, where applicable, in the master reference set.

Copies of the master reference set are maintained at the NMED Hazardous Waste Bureau; DOE-Los Alamos Site Office; EPA, Region 6; and the Directorate. The set was developed to ensure that the administrative authority has all material needed to review this document, and it is updated with every document submitted to the administrative authority. Documents previously submitted to the administrative authority are not included.

Allen, S.P., and R.J. Koch, March 2008. "Groundwater Level Status Report for Fiscal Year 2007, Los Alamos National Laboratory," Los Alamos National Laboratory report LA-14358-PR, Los Alamos, New Mexico. (Allen and Koch 2008, 101613)

BAER (Burned Area Emergency Rehabilitation), June 9, 2000. "Cerro Grande Fire, Burned Area Emergency Rehabilitation (BAER) Plan: Interagency Burned Area Emergency Rehabilitation Team," Los Alamos, New Mexico. (BAER 2000, 072659)

Ball, T., M. Everett, P. Longmire, D. Vaniman, W. Stone, D. Larssen, K. Greene, N. Clayton, and S. McLin, February 2002. "Characterization Well R-22 Completion Report," Los Alamos National Laboratory report LA-13893-MS, Los Alamos, New Mexico. (Ball et al. 2002, 071471)

Bennett, K.D., R. Robinson, D. Keller, S. Frybarger, M. Tardiff, and D. Hickmott, March 2002. "Spring and Fall Small Mammal Sampling Record for Cañon de Valle and Pajarito Canyon, 2001," Los Alamos National Laboratory report LA-13916-PR, Los Alamos, New Mexico. (Bennett et al. 2002, 073796)

Birdsell, K., September 3, 2008. Interview with Charlene Cappiello Concerning Potential Releases, Chemicals Used, and Status of TA-18, Los Alamos, New Mexico. (Birdsell 2008, 102779)

Breault, R.F., and G.E. Granato, 2000. "A Synopsis of Technical Issues of Concern for Monitoring Trace Elements in Highway and Urban Runoff," U.S. Geological Survey Open-File Report 00-422, Denver, Colorado. (Breault and Granato 2000, 082310)

Broxton, D., D. Vaniman, W. Stone, S. McLin, J. Marin, R. Koch, R. Warren, P. Longmire, D. Rogers, and N. Tapia, May 2001. "Characterization Well R-19 Completion Report," Los Alamos National Laboratory report LA-13823-MS, Los Alamos, New Mexico. (Broxton et al. 2001, 071254)

Callender, E., and K.C. Rice, 2000. "The Urban Environmental Gradient: Anthropogenic Influences on the Spatial and Temporal Distributions of Lead and Zinc in Sediments," *Environmental Science & Technology*, Vol. 34, No. 2, pp. 232-238. (Callender and Rice 2000, 082307)

Chou, S.F.J., and R.A. Griffin, 1986. "Solubility and Soil Mobility of Polychlorinated Biphenyls," Chapter 5 of *PCBs and the Environment*, Vol. 1, CRC Press, Boca Raton, Florida, pp. 101-120. (Chou and Griffin 1986, 083419)

- Clark, I.D., and P. Fritz, 1997. *Environmental Isotopes in Hydrogeology*, Lewis Publishers, Boca Raton, Florida. (Clark and Fritz 1997, 059168)
- Colestock, K.L., and J.M. Fair, 2005. "Avian Individual and Population Health on Los Alamos National Laboratory 2005: Foraging Effects and Egg Contaminant Residues," Los Alamos National Laboratory document LA-UR-05-7272, Los Alamos, New Mexico. (Colestock and Fair 2005, 093691)
- Cross, S., September 1995. "Aquatic Invertebrate Sampling at Selected Outfalls in Operable Unit 1082; Technical Areas 9, 11, 16, and 22," Los Alamos National Laboratory report LA-13019-MS, Los Alamos, New Mexico. (Cross 1995, 092221)
- Dale, M., K. Granzow, P. Longmire, D. Englert, M. Rearick, and G. Perkins, July 9, 2008. "Naturally Occurring Perchlorate in Ground Water, Northern Rio Grande Basin, New Mexico," Department of Energy Oversight Bureau, New Mexico Environment Department, Santa Fe, New Mexico. (Dale et al. 2008, 102797)
- Dale, M.R., S.M. Yanicak, and S.P. Anderson, December 1996. "Ground-Water Oversight at Los Alamos National Laboratory and Surrounding Areas, 1994 Through 1995," NMED/DOE/AIP-96/4, Department of Energy Oversight Bureau, New Mexico Environment Department, Santa Fe, New Mexico. (Dale et al. 1996, 057014)
- Dethier, D.P., 1997. "Geology of White Rock Quadrangle, Los Alamos and Santa Fe Counties, New Mexico," Map 73, New Mexico Bureau of Mines and Mineral Resources. (Dethier 1997, 049843)
- Devaurs, M., November 1985. "Core Analyses and Observation Well Data from Mesita del Buey Waste Disposal Area and in Adjacent Canyons," Los Alamos National Laboratory document LA-UR-85-4003, Los Alamos, New Mexico. (Devaurs 1985, 007416)
- Devaurs, M., and W.D. Purtymun, 1985. "Hydrologic Characteristics of the Alluvial Aquifers in Mortandad, Cañada del Buey, and Pajarito Canyons," Los Alamos National Laboratory document LA-UR-85-4002, Los Alamos, New Mexico. (Devaurs and Purtymun 1985, 007415)
- DOE (U.S. Department of Energy), June 13, 2000. "Procedure for the Release of Residual Radioactive Material from Real Property," U.S. Department of Energy memorandum to D. Glenn, I.R. Triay, M. Zamorski, E. Sellers, D. Gurule, and D. Bergman-Tabbert from C.L. Soden, Albuquerque, New Mexico. (DOE 2000, 067489)
- DOE (U.S. Department of Energy), July 2002. "A Graded Approach for Evaluating Radiation Doses to Aquatic and Terrestrial Biota," DOE Standard DOE/STD-1153-2002, U.S. Department of Energy, Washington, D.C. (DOE 2002, 085637)
- DOE (U.S. Department of Energy), January 2004. "RESRAD-BIOTA: A Tool for Implementing a Graded Approach to Biota Dose Evaluation, User's Guide, Version 1," ISCORS Technical Report 2004-02, U.S. Department of Energy document DOE/EH-0676, Washington, D.C. (DOE 2004, 085639)
- Dourson, M.L., and J.F. Stara, 1983. "Regulatory History and Experimental Support of Uncertainty (Safety) Factors," *Regulatory Toxicology and Pharmacology*, Vol. 3, pp. 224-238. (Dourson and Stara 1983, 073474)
- Drakos, P., R. Rytí, S. Reneau, and K. Greene, October 2000. "Evaluation of Possible Sediment Contamination in the White Rock Land Transfer Parcel: Reach CDB-4," Los Alamos National Laboratory document LA-UR-00-5071, Los Alamos, New Mexico. (Drakos et al. 2000, 068739)

- Edwards, N.T., 1983. "Polycyclic Aromatic Hydrocarbons (PAH's) in the Terrestrial Environment - A Review," *Journal of Environmental Quality*, Vol. 12, No. 4, pp. 427-441. (Edwards 1983, 082302)
- EP&T (Ecological Planning and Toxicology, Inc.), September 2005. "Bioassays Using *Eisenia fetida* to Assess Mortality of Chemicals of Concern in Soils," document prepared for Los Alamos National Laboratory by Ecological Planning and Toxicology, Inc., Corvallis, Oregon. (EP&T 2005, 091267)
- EPA (U.S. Environmental Protection Agency), December 1989. "Risk Assessment Guidance for Superfund, Volume I: Human Health Evaluation Manual (Part A), Interim Final," EPA/540/1-89/002, Office of Emergency and Remedial Response, Washington, D.C. (EPA 1989, 008021)
- EPA (U.S. Environmental Protection Agency), April 10, 1990. "Module VIII of RCRA Permit No. NM0890010515, issued to Los Alamos National Laboratory, Los Alamos, New Mexico," EPA Region VI, Hazardous Waste Management Division, Dallas, Texas. (EPA 1990, 001585)
- EPA (U.S. Environmental Protection Agency), December 1993. "Wildlife Exposure Factors Handbook," Vol. I of II, EPA/600/R-93/187a, Office of Research and Development, Washington, D.C. (EPA 1993, 059384)
- EPA (U.S. Environmental Protection Agency), April 19, 1994. "Module VIII of RCRA Permit No. NM0890010515, EPA, Region 6, New Requirements Issued to Los Alamos National Laboratory, Los Alamos, New Mexico," EPA Region 6, Hazardous Waste Management Division, Dallas, Texas. (EPA 1994, 044146)
- EPA (U.S. Environmental Protection Agency), June 5, 1997. "Ecological Risk Assessment Guidance for Superfund: Process for Designing and Conducting Ecological Risk Assessments, Interim Final," Office of Emergency and Remedial Response, Washington, D.C. (EPA 1997, 059370)
- EPA (U.S. Environmental Protection Agency), August 1997. "Exposure Factors Handbook, Volume I, General Factors," EPA/600/P-95/002Fa, Office of Research and Development, Washington, D.C. (EPA 1997, 066596)
- EPA (U.S. Environmental Protection Agency), 1999. "Rapid Bioassessment Protocols for Use in Streams and Wadeable Rivers: Periphyton, Benthic Macroinvertebrates, and Fish," 2nd ed., EPA 841-B-99-002, Office of Water, Washington, D.C. (EPA 1999, 073728)
- EPA (U.S. Environmental Protection Agency), March 2000. "Test Method 100.2, *Chironomus tentans* 10-d Survival Growth Test for Sediments," in *Methods for Measuring the Toxicity and Bioaccumulation of Sediment-associated Contaminants with Freshwater Invertebrates*, 2nd ed., EPA 600/R-99/064, Office of Research and Development, Duluth, Minnesota, Office of Science and Technology, Office of Water, Washington, D.C. (EPA 2000, 073776)
- EPA (U.S. Environmental Protection Agency), March 2001. "Sampling Report, Los Alamos National Laboratory, Los Alamos, New Mexico," report prepared for the Environmental Protection Agency by TechLaw, Inc., Dallas, Texas. (EPA 2001, 070669)
- EPA (U.S. Environmental Protection Agency), December 2001. "Risk Assessment Guidance for Superfund: Volume III - Part A, Process for Conducting Probabilistic Risk Assessment," EPA 540-R-02-002, Office of Emergency and Remedial Response, Washington, D.C. (EPA 2001, 085534)
- EPA (U.S. Environmental Protection Agency), November 2003. "Ecological Soil Screening Level for Aluminum, Interim Final," OSWER Directive No. 9285.7-60, Office of Solid Waste and Emergency Response, Washington, D.C. (EPA 2003, 085645)

- EPA (U.S. Environmental Protection Agency), November 2003. "Guidance for Developing Ecological Soil Screening Levels," OSWER Directive No. 92857-55, Office of Solid Waste and Emergency Response, Washington, D.C. (EPA 2003, 085643)
- EPA (U.S. Environmental Protection Agency), November 2005. "EPA Region 6 Human Health Medium-Specific Screening Levels," U.S. EPA Region 6, Dallas, Texas. (EPA 2005, 091002)
- EPA (U.S. Environmental Protection Agency), December 2007. "EPA Region 6 Human Health Medium-Specific Screening Levels," U.S. EPA Region 6, Dallas, Texas. (EPA 2007, 099314)
- Fair, J.M., and O.B. Myers, 2002. "Early Reproductive Success of Western Bluebirds and Ash-Throated Flycatchers: A Landscape-Contaminant Perspective," *Environmental Pollution*, Vol. 118, pp. 321-330. (Fair and Myers 2002, 082655)
- Ford-Schmid, R., 1996. "Reference Conditions for Los Alamos National Laboratory Streams Using Benthic Macroinvertebrate Assessment in Upper Pajarito Canyon," *New Mexico Geological Society Guidebook: 47th Field Conference, Jemez Mountains Region, New Mexico*, pp. 441-448. (Ford-Schmid 1996, 059111)
- Fresquez, P.R., and J.K. Ferenbaugh, 1999. "Moisture Conversion Ratios for the Foodstuffs and Biota Environmental Surveillance Programs at Los Alamos National Laboratory (Revision 1)," Los Alamos National Laboratory document LA-UR-99-253, Los Alamos, New Mexico. (Fresquez and Ferenbaugh 1999, 091269)
- Gallaher, B.M., and R.J. Koch, September 2004. "Cerro Grande Fire Impacts to Water Quality and Stream Flow near Los Alamos National Laboratory: Results of Four Years of Monitoring," Los Alamos National Laboratory report LA-14177, Los Alamos, New Mexico. (Gallaher and Koch 2004, 088747)
- Gardner, J.N., A. Lavine, G. WoldeGabriel, D. Krier, J., D.T. Vaniman, F.A. Caporuscio, C.J. Lewis, M.R. Reneau, E.C. Kluk, and M.J. Snow, March 1999. "Structural Geology of the Northwestern Portion of Los Alamos National Laboratory, Rio Grande Rift, New Mexico: Implications for Seismic Surface Rupture Potential from TA-3 to TA-55," Los Alamos National Laboratory report LA-13589-MS, Los Alamos, New Mexico. (Gardner et al. 1999, 063492)
- Geophex, January 2006. "DC Resistivity Profiling in DP, Los Alamos, Pajarito, Pueblo and Sandia Canyons, Los Alamos National Laboratory, Los Alamos, NM," report prepared for Los Alamos National Laboratory, Los Alamos, New Mexico. (Geophex 2006, 094047)
- Goering, D., April 17, 2006. Pajarito Canyon. E-mail message to D. Katzman (LANL) from D. Goering (NMED), Santa Fe, New Mexico. (Goering 2006, 093027)
- Gonzales, G., R. Ryti, P. Gallegos, and K. Bennett, September 2008. "The Application of ECORSK.9 to the Pajarito Canyon Watershed at the Los Alamos National Laboratory," Los Alamos National Laboratory report LA-14374, Los Alamos, New Mexico. (Gonzales et al. 2008, 102790)
- Graf, W.L., October 1996. "Transport and Deposition of Plutonium-Contaminated Sediments by Fluvial Processes, Los Alamos Canyon, New Mexico," *Geological Society of America Bulletin*, Vol. 108, No. 10, pp. 1342-1355. (Graf 1996, 055537)
- Griggs, R.L., and J.D. Hem, 1964. "Geology and Ground-Water Resources of the Los Alamos Area, New Mexico," U.S. Geological Survey Water Supply Paper 1753, Washington, D.C. (Griggs and Hem 1964, 092516)

- Henne, L., September 2008. "Evaluation of Aquatic Macroinvertebrate Communities and Habitats in the Pajarito Watershed," Los Alamos National Laboratory document LA-UR-08-6090, Los Alamos, New Mexico. (Henne 2008, 102991)
- Jansen, J., and T. Taylor, May 29, 1997. "Submittal of the RFI Status Report for Tritium in Surface Soils at MDA G in TA-54," Los Alamos National Laboratory memorandum (EM/ER:97-195) to B. Garcia (NMED) from J. Jansen (EM/ER), and T. Taylor (DOE), Los Alamos, New Mexico. (Jansen and Taylor 1997, 055873)
- Katzman, D., R. Ryti, and S. Reneau, 2001. "Cerro Grande Ash as a Source of Elevated Radionuclides and Metals," in *Water, Watersheds, and Land Use in New Mexico, Impacts of Population Growth on Natural Resources, Santa Fe Region 2001*, New Mexico Bureau of Mines and Mineral Resources, Socorro, New Mexico. (Katzman et al. 2001, 072660)
- Kleinfelder, April 2005. "Final Completion Report, Characterization Well R-18," report prepared for Los Alamos National Laboratory, Project No. 37151, Albuquerque, New Mexico. (Kleinfelder 2005, 092415)
- Kleinfelder, March 2006. "Final Completion Report, Intermediate Well R-23i," report prepared for Los Alamos National Laboratory, Project No. 49436, Albuquerque, New Mexico. (Kleinfelder 2006, 092495)
- Kleinfelder, May 2006. "Final Completion Report, Characterization Well R-17," report prepared for Los Alamos National Laboratory, Project No. 49436, Albuquerque, New Mexico. (Kleinfelder 2006, 092493)
- Kleinfelder, March 2007. "Final Rev. 1, Rehabilitation Report for Regional Wells R-20 and R-16," report prepared for Los Alamos National Laboratory, Project No. 68402, Albuquerque, New Mexico. (Kleinfelder 2007, 095030.2)
- Kraig, D.H., R. Ryti, D. Katzman, T. Buhl, B. Gallaher, and P. Fresquez, March 2002. "Radiological and Nonradiological Effects After the Cerro Grande Fire," Los Alamos National Laboratory report LA-13914, Los Alamos, New Mexico. (Kraig et al. 2002, 085536)
- LANL (Los Alamos National Laboratory), November 1990. "Solid Waste Management Units Report," Vol. IV of IV (TA-51 through TA-74), Los Alamos National Laboratory document LA-UR-90-3400, Los Alamos, New Mexico. (LANL 1990, 007514)
- LANL (Los Alamos National Laboratory), June 1995. "Expedited Cleanup Plan for Solid Waste Management Unit 3-056(c)," Rev. 0, Los Alamos Scientific Laboratory, Los Alamos, New Mexico. (LANL 1995, 047257)
- LANL (Los Alamos National Laboratory), April 28, 1995. "RFI Report for Field Unit 1, SWMU 3-010(a)," Los Alamos National Laboratory document LA-UR-95-1485, Los Alamos, New Mexico. (LANL 1995, 046195)
- LANL (Los Alamos National Laboratory), November 2, 1995. "RFI Report for Potential Release Sites 18-002(a-c), 18-003(a-h), 18-004(a,b), 18-005(a), 18-008, 18-010(b-f), 18-011, 18-012(a-c), 18-013, 27-002, PCO Wells, LACEF Monitoring Wells, Wetlands (located in former Operable Unit 1093)," Los Alamos National Laboratory, Los Alamos, New Mexico. (LANL 1995, 055527)

- LANL (Los Alamos National Laboratory), February 1996. "RFI Report for Channel Sediment Pathways from MDAs G, H, J, and L, TA-54 (located in former Operable Unit 1148)," Los Alamos National Laboratory document LA-UR-96-110, Los Alamos, New Mexico. (LANL 1996, 054462)
- LANL (Los Alamos National Laboratory), February 26, 1996. "Voluntary Corrective Action Completion Report for Potential Release Sites C-09-001, 69-001, Revision 1," Los Alamos National Laboratory document LA-UR-96-1125, Los Alamos, New Mexico. (LANL 1996, 054334)
- LANL (Los Alamos National Laboratory), April 1996. "Addendum RFI Report for Potential Release Sites 18-002(a,b), 18-003(a-h), 18-004(a,b), 18-005(a), 18-008, 18-010(b-f), 18-011, 18-012(a-c), 18-013, 27-002, PCO Wells, Wetlands, LACEF Monitoring Wells (located in former Operable Unit 1093)," Los Alamos National Laboratory document LA-UR-95-3833, Los Alamos, New Mexico. (LANL 1996, 054919)
- LANL (Los Alamos National Laboratory), April 1997. "Core Document for Canyons Investigations," Los Alamos National Laboratory document LA-UR-96-2083, Los Alamos, New Mexico. (LANL 1997, 055622)
- LANL (Los Alamos National Laboratory), June 1997. "RFI Report for Groundwater Sampling, PRS 18-003(d), TA-18," Los Alamos National Laboratory document LA-UR-97-2856, Los Alamos, New Mexico. (LANL 1997, 057015)
- LANL (Los Alamos National Laboratory), January 23, 1998. "Supplement to Response to Request for Supplemental Information for the Canyons Investigation Core Work Plan (Former OU 1049)," Los Alamos National Laboratory letter (EM/ER:98-020) to B. Garcia (NMED-HRMB) from J. Canepa (ER Program Manager) and T.J. Taylor (DOE-LAAO), Los Alamos, New Mexico. (LANL 1998, 057666)
- LANL (Los Alamos National Laboratory), May 22, 1998. "Hydrogeologic Workplan," Los Alamos National Laboratory document LA-UR-01-6511, Los Alamos, New Mexico. (LANL 1998, 059599)
- LANL (Los Alamos National Laboratory), September 1998. "Work Plan for Pajarito Canyon," Los Alamos National Laboratory document LA-UR-98-2550, Los Alamos, New Mexico. (LANL 1998, 059577)
- LANL (Los Alamos National Laboratory), September 22, 1998. "Inorganic and Radionuclide Background Data for Soils, Canyon Sediments, and Bandelier Tuff at Los Alamos National Laboratory," Los Alamos National Laboratory document LA-UR-98-4847, Los Alamos, New Mexico. (LANL 1998, 059730)
- LANL (Los Alamos National Laboratory), June 2003. "Characterization Well R-20 Completion Report," Los Alamos National Laboratory document LA-UR-03-1839, Los Alamos, New Mexico. (LANL 2003, 079600)
- LANL (Los Alamos National Laboratory), June 2003. "Characterization Well R-23 Completion Report," Los Alamos National Laboratory document LA-UR-03-2059, Los Alamos, New Mexico. (LANL 2003, 079601)
- LANL (Los Alamos National Laboratory), June 2003. "Characterization Well R-32 Completion Report," Los Alamos National Laboratory document LA-UR-03-3984, Los Alamos, New Mexico. (LANL 2003, 079602)
- LANL (Los Alamos National Laboratory), September 2003. "Phase III RFI Report for Solid Waste Management Unit 16-021(c)-99," Los Alamos National Laboratory document LA-UR-03-5248, Los Alamos, New Mexico. (LANL 2003, 077965)

- LANL (Los Alamos National Laboratory), October 2003. "Groundwater Investigation Work Plan for Solid Waste Management Unit 3-010(a) at Technical Area 3," Los Alamos National Laboratory document LA-UR-03-7349, Los Alamos, New Mexico. (LANL 2003, 081599)
- LANL (Los Alamos National Laboratory), November 2004. "Draft Technical Approach for Calculating Recreational Soil Screening Levels for Chemicals," Los Alamos National Laboratory document LA-UR-04-7743, Los Alamos, New Mexico. (LANL 2004, 087800)
- LANL (Los Alamos National Laboratory), April 2004. "Los Alamos and Pueblo Canyons Investigation Report," Los Alamos National Laboratory document LA-UR-04-2714, Los Alamos, New Mexico. (LANL 2004, 087390)
- LANL (Los Alamos National Laboratory), December 2004. "Screening-Level Ecological Risk Assessment Methods, Revision 2," Los Alamos National Laboratory document LA-UR-04-8246, Los Alamos, New Mexico. (LANL 2004, 087630)
- LANL (Los Alamos National Laboratory), January 2005. "Field Summary Report for Sediment Sampling Activity in Reaches CDB-3 East and PA-4, Cañada del Buey and Pajarito Canyon, Downgradient of Material Disposal Area G," Los Alamos National Laboratory document LA-UR-05-0104, Los Alamos, New Mexico. (LANL 2005, 088716)
- LANL (Los Alamos National Laboratory), May 2005. "Mortandad Canyon Biota Investigation Work Plan," Los Alamos National Laboratory document LA-UR-05-2231, Los Alamos, New Mexico. (LANL 2005, 089308)
- LANL (Los Alamos National Laboratory), May 2005. "Derivation and Use of Radionuclide Screening Action Levels, Revision 1," Los Alamos National Laboratory document LA-UR-05-1849, Los Alamos, New Mexico. (LANL 2005, 088493)
- LANL (Los Alamos National Laboratory), July 27, 2005. "Response to the Notice of Disapproval for the Work Plan for Pajarito Canyon," Los Alamos National Laboratory document LA-UR-05-5600, Los Alamos, New Mexico. (LANL 2005, 091287)
- LANL (Los Alamos National Laboratory), September 2005. "Investigation Report for Material Disposal Area G, Consolidated Unit 54-013(b)-99, at Technical Area 54," Los Alamos National Laboratory document LA-UR-05-6398, Los Alamos, New Mexico. (LANL 2005, 090513)
- LANL (Los Alamos National Laboratory), September 2005. "Ecorisk Database (Release 2.2)," on CD, LA-UR-05-7424, Los Alamos National Laboratory, Los Alamos, New Mexico. (LANL 2005, 090032)
- LANL (Los Alamos National Laboratory), December 2005. "Los Alamos and Pueblo Canyons Supplemental Investigation Report," Los Alamos National Laboratory document LA-UR-05-9230, Los Alamos, New Mexico. (LANL 2005, 091818)
- LANL (Los Alamos National Laboratory), July 2006. "Summary of Watersheds Potentially Impacted by the Los Alamos National Laboratory," Los Alamos National Laboratory document LA-UR-06-5387, Los Alamos, New Mexico. (LANL 2006, 094004)
- LANL (Los Alamos National Laboratory), March 2006. "Summary of Pajarito Canyon Phase 1 Sediment Investigations," Los Alamos National Laboratory document LA-UR-06-1545, Los Alamos, New Mexico. (LANL 2006, 091812)

- LANL (Los Alamos National Laboratory), July 2006. "Pajarito Canyon Biota Investigation Work Plan," Los Alamos National Laboratory document LA-UR-06-4106, Los Alamos, New Mexico. (LANL 2006, 093553)
- LANL (Los Alamos National Laboratory), October 2006. "Mortandad Canyon Investigation Report," Los Alamos National Laboratory document LA-UR-06-6752, Los Alamos, New Mexico. (LANL 2006, 094161)
- LANL (Los Alamos National Laboratory), May 2007. "Groundwater Background Investigation Report, Revision 3," Los Alamos National Laboratory document LA-UR-07-2853, Los Alamos, New Mexico. (LANL 2007, 095817)
- LANL (Los Alamos National Laboratory), March 2007. "Summary of Pajarito Canyon Phase 2 Sediment Investigations," Los Alamos National Laboratory document LA-UR-07-1497, Los Alamos, New Mexico. (LANL 2007, 095408)
- LANL (Los Alamos National Laboratory), March 2007. "Storm Water Pollution Prevention Plan for SWMUs and AOCs (Sites) and Storm Water Monitoring Plan, Annual Update - 2007," Los Alamos National Laboratory document LA-UR-07-1789, Los Alamos, New Mexico. (LANL 2007, 096981)
- LANL (Los Alamos National Laboratory), May 2007. "Well Screen Analysis Report, Revision 2," Los Alamos National Laboratory document LA-UR-07-2852, Los Alamos, New Mexico. (LANL 2007, 096330)
- LANL (Los Alamos National Laboratory), May 2007. "2007 Interim Facility-Wide Groundwater Monitoring Plan," Los Alamos National Laboratory document LA-UR-07-3271, Los Alamos, New Mexico. (LANL 2007, 096665)
- LANL (Los Alamos National Laboratory), July 2007. "Technical Area 54 Well Evaluation and Network Recommendations," Los Alamos National Laboratory document LA-UR-07-5042, Los Alamos, New Mexico. (LANL 2007, 098172)
- LANL (Los Alamos National Laboratory), September 2007. "Environmental Surveillance at Los Alamos During 2006," Los Alamos National Laboratory report LA-14341-ENV, Los Alamos, New Mexico. (LANL 2007, 098644)
- LANL (Los Alamos National Laboratory), December 2007. "Well R-32 Rehabilitation and Conversion Summary Report, Revision 1," Los Alamos National Laboratory document LA-UR-07-8074, Los Alamos, New Mexico. (LANL 2007, 100572)
- LANL (Los Alamos National Laboratory), February 2008. "Los Alamos and Pueblo Canyons Groundwater Monitoring Well Network Evaluation and Recommendations, Revision 1," Los Alamos National Laboratory document LA-UR-08-1105, Los Alamos, New Mexico. (LANL 2008, 101330)
- LANL (Los Alamos National Laboratory), May 2008. "2008 Interim Facility-Wide Groundwater Monitoring Plan," Los Alamos National Laboratory document LA-UR-08-3273, Los Alamos, New Mexico. (LANL 2008, 101897)
- LANL (Los Alamos National Laboratory), September 12, 2008. "Well Rehabilitation Plan for Fiscal Year 2009," Los Alamos National Laboratory letter (EP2008-0497) to J.P. Bearzi (NMED-HWB) from S. Stiger (LANL) and D. Gregory (DOE-LASO), Los Alamos, New Mexico. (LANL 2008, 102998)
- LASL (Los Alamos Scientific Laboratory), June 6, 1963. "DDT and the Spruce Budworm," Los Alamos Scientific Laboratory News, p. 3, Los Alamos, New Mexico. (LANL 1963, 064879)

- Lewis, C.J., A. Lavine, S.L. Reneau, J.N. Gardner, R. Channell, and C.W. Criswell, December 2002. "Geology of the Western Part of Los Alamos National Laboratory (TA-3 to TA-16), Rio Grande Rift, New Mexico," Los Alamos National Laboratory report LA-13960-MS, Los Alamos, New Mexico. (Lewis et al. 2002, 073785)
- Longmire, P., October 2002. "Characterization Well R-22 Geochemistry Report," Los Alamos National Laboratory report LA-13986-MS, Los Alamos, New Mexico. (Longmire 2002, 073676)
- Longmire, P., M. Dale, D. Counce, A. Manning, T. Larson, K. Granzow, R. Gray, and B. Newman, July 2007. "Radiogenic and Stable Isotope and Hydrogeochemical Investigation of Groundwater, Pajarito Plateau and Surrounding Areas, New Mexico," Los Alamos National Laboratory report LA-14333, Los Alamos, New Mexico. (Longmire et al. 2007, 096660)
- Lopes, T.J., and S.G. Dionne, 1998. "A Review of Semivolatile and Volatile Organic Compounds in Highway Runoff and Urban Stormwater," U.S. Geological Survey Open-File Report 98-409, Denver, Colorado. (Lopes and Dionne 1998, 082309)
- Malmon, D.V., June 2002. "Sediment Trajectories Through a Semiarid Valley," Ph.D. dissertation, University of California, Santa Barbara, California. (Malmon 2002, 076038)
- Malmon, D.V., S.L. Reneau, T. Dunne, D. Katzman, and P.G. Drakos, 2005. "Influence of Sediment Storage on Downstream Delivery of Contaminated Sediment," *Water Resources Research*, Vol. 41, W05008, 17 pp. (Malmon et al. 2005, 093540)
- Marcus, W.A., 1987. "Copper Dispersion in Ephemeral Stream Sediments," *Earth Surface Processes and Landforms*, Vol. 12, pp. 217-228. (Marcus 1987, 082301)
- McDonald, E., R.T. Rytí, S.L. Reneau, and D. Carlson, May 2, 2003. "Natural Background Geochemistry and Statistical Analysis of Sediments, Los Alamos National Laboratory," Los Alamos National Laboratory document LA-UR-03-2661, Los Alamos, New Mexico. (McDonald et al. 2003, 076084)
- Neff, J.M., 1979. *Polycyclic Aromatic Hydrocarbons in the Aquatic Environment: Sources, Fates and Biological Effects*, Applied Science Publishers Ltd, London, England. (Neff 1979, 083420)
- Nelson, E., T. Haarmann, D. Keller, T. Foxx, and M. Mullen, July 1998. "Studies of Annual and Seasonal Variations in Four Species of Reptiles and Amphibians at Los Alamos National Laboratory," Los Alamos National Laboratory report LA-13476-MS, Los Alamos, New Mexico. (Nelson et al. 1998, 092224)
- NMED (New Mexico Environment Department), March 26, 1997. "Submittal of 1996 Ground-Water Data Related to Split-Sampling and Independent Sampling at Los Alamos National Laboratory and Surrounding Areas," New Mexico Environment Department letter to M. Johansen (DOE-LAAO) from S. Yanicak (NMED DOE Oversight Bureau), Santa Fe, New Mexico. (NMED 1997, 057582)
- NMED (New Mexico Environment Department), March 17, 1998. "Approval of the Canyons Investigation Work Plan," New Mexico Environment Department letter to T. Taylor (DOE-LAAO) and J.C. Browne (LANL Director) from R.S. Dinwiddie (NMED-HRMB), Santa Fe, New Mexico. (NMED 1998, 058638)

- NMED (New Mexico Environment Department), November 24, 2003. "LANL's Risk Reduction and Environmental Stewardship (RRES) Remediation Services Project Use of Surrogate Chemicals in Risk Assessments," New Mexico Environment Department letter to D. Gregory (DOE-LASO) and G.P. Nanos (LANL Director) from J.E. Kieling (NMED-HWB), Santa Fe, New Mexico. (NMED 2003, 081172)
- NMED (New Mexico Environment Department), May 31, 2005. "Notice of Disapproval, Pajarito Canyon Work Plan," New Mexico Environment Department letter to D. Gregory (DOE-LASO) and G.P. Nanos (LANL Director) from J.P. Bearzi (NMED-HWB), Santa Fe, New Mexico. (NMED 2005, 089315)
- NMED (New Mexico Environment Department), October 11, 2005. "Approval with Modifications, Pajarito Canyon Work Plan," New Mexico Environment Department letter to D. Gregory (DOE-LASO) and D. McInroy (LANL) from J.P. Bearzi (NMED-HWB), Santa Fe, New Mexico. (NMED 2005, 091288)
- NMED (New Mexico Environment Department), June 2006. "Technical Background Document for Development of Soil Screening Levels, Revision 4.0, Volume 1, Tier 1: Soil Screening Guidance Technical Background Document," New Mexico Environment Department, Hazardous Waste Bureau and Ground Water Quality Bureau Voluntary Remediation Program, Santa Fe, New Mexico. (NMED 2006, 092513)
- NMED (New Mexico Environment Department), February 23, 2007. "Approval with Direction, Mortandad Canyon Investigation Report," New Mexico Environment Department letter to D. Gregory (DOE LASO) and D. McInroy (LANL) from J.P. Bearzi (NMED HWB), Santa Fe, New Mexico. (NMED 2007, 095109)
- NMED (New Mexico Environment Department), April 5, 2007. "Well Evaluations for Intermediate and Regional Wells," New Mexico Environment Department letter to D. Gregory (DOE LASO) and D. McInroy (LANL) from J.P. Bearzi (NMED HWB), Santa Fe, New Mexico. (NMED 2007, 095999)
- NMED (New Mexico Environment Department), May 29, 2007. "Notice of Approval, Pajarito Canyon Biota Investigation Work Plan," New Mexico Environment Department letter to D. Gregory (DOE-LASO) and D. McInroy (LANL) from J.P. Bearzi (NMED-HWB), Santa Fe, New Mexico. (NMED 2007, 096332)
- NMED (New Mexico Environment Department), May 29, 2007. "Notice of Approval, Proposed Phase 3 Sediment Investigation in Pajarito Canyon," New Mexico Environment Department letter to D. Gregory (DOE-LASO) and D. McInroy (LANL) from J.P. Bearzi (NMED-HWB), Santa Fe, New Mexico. (NMED 2007, 096474)
- NMED (New Mexico Environment Department), August 31, 2007. "Approval with Direction, Technical Area 54 Well Evaluation and Network Recommendations," New Mexico Environment Department letter to D. Gregory (DOE LASO) and D. McInroy (LANL) from J.P. Bearzi (NMED HWB), Santa Fe, New Mexico. (NMED 2007, 098283)
- Nowell, L.H., P.D. Capel, and P.D. Dileanis, *Pesticides in Stream Sediment and Aquatic Biota: Distribution, Trends, and Governing Factors*, Lewis Publishers, Boca Raton, Florida. (Nowell et al. 1999, 083422)
- Pionke, H.B., and G. Chesters, 1973. "Pesticide-Sediment-Water Interactions," *Journal of Environmental Quality*, Vol. 2, No. 1, pp. 29-45. (Pionke and Chesters 1973, 083423)

- Purtymun, W.D., February 1971. "Plutonium in Stream Channel Alluvium in the Los Alamos Area, New Mexico," Los Alamos Scientific Laboratory report LA-4561, Los Alamos, New Mexico. (Purtymun 1971, 004795)
- Purtymun, W.D., April 1973. "Regional Survey of Tritium in Surface and Ground Water in the Los Alamos Area, New Mexico, August 1966 through May 1969," Los Alamos Scientific Laboratory report LA-5234-MS, Los Alamos, New Mexico. (Purtymun 1973, 004971)
- Purtymun, W.D., December 1975. "Geohydrology of the Pajarito Plateau with Reference to Quality of Water, 1949-1972," Informal Report, Los Alamos Scientific Laboratory document LA-UR-02-4726, Los Alamos, New Mexico. (Purtymun 1975, 011787)
- Purtymun, W.D., January 1995. "Geologic and Hydrologic Records of Observation Wells, Test Holes, Test Wells, Supply Wells, Springs, and Surface Water Stations in the Los Alamos Area," Los Alamos National Laboratory report LA-12883-MS, Los Alamos, New Mexico. (Purtymun 1995, 045344)
- Reneau, S.L., P.G. Drakos, D. Katzman, D.V. Malmon, E.V. McDonald, and R.T. Ryti, 2004. "Geomorphic Controls on Contaminant Distribution Along an Ephemeral Stream," *Earth Surface Processes and Landforms*, Vol. 29, pp. 1209-1223. (Reneau et al. 2004, 093174)
- Reneau, S.L., D. Katzman, G.A. Kuyumjian, A. Lavine, and D.V. Malmon, February 2007. "Sediment Delivery After a Wildfire," *Geology*, Vol. 35, No. 2, pp. 151-154. (Reneau et al. 2007, 102886)
- Salomons, W., and U. Forstner, 1984. *Metals in the Hydrocycle*, Springer-Verlag, Berlin, Germany. (Salomons and Forstner 1984, 082304)
- Shaul, D.A., M.R. Alexander, R.P. Reynolds, C.T. McLean, R.P. Romero, and E.T. Riebsomer, June 2001. "Surface Water Data at Los Alamos National Laboratory: 2000 Water Year," Los Alamos National Laboratory report LA-13814-PR, Los Alamos, New Mexico. (Shaul et al. 2001, 072609.112)
- Smith, R.L., R.A. Bailey, and C.S. Ross, 1970. "Geologic Map of the Jemez Mountains, New Mexico," U.S. Geological Survey Miscellaneous Investigations Series, Map I-571, Washington, D.C. (Smith et al. 1970, 009752)
- Van Metre, P.C., B.J. Mahler, and E.T. Furlong, 2000. "Urban Sprawl Leaves Its PAH Signature," *Environmental Science & Technology*, Vol. 34, pp. 4064-4070. (Van Metre et al. 2000, 082262)
- Walker, W.J., R.P. McNutt, and C.K. Maslanka, 1999. "The Potential Contribution of Urban Runoff to Surface Sediments of the Passaic River: Sources and Chemical Characteristics," *Chemosphere*, Vol. 38, No. 2, pp. 363-377. (Walker et al. 1999, 082308)
- Walvoord, M.A., F.M. Phillips, D.A. Stonestrom, R.D. Evans, P.C. Hartsough, B.D. Newman, and R.G. Striegl, November 7, 2003. "A Reservoir of Nitrate Beneath Desert Soils," *Science*, Vol. 302, pp. 1022-1024. (Walvoord et al. 2003, 093787)
- Yanicak, S., February 1998. "Release of Ground and Surface Water Data Related to Split Sampling and Independent Sampling at Los Alamos National Laboratory and Surrounding Areas during 1996 and 1997," New Mexico Environment Department letter to M. Johansen (DOE LAAO) from S. Yanicak (NMED), Santa Fe, New Mexico. (Yanicak 1998, 057583)

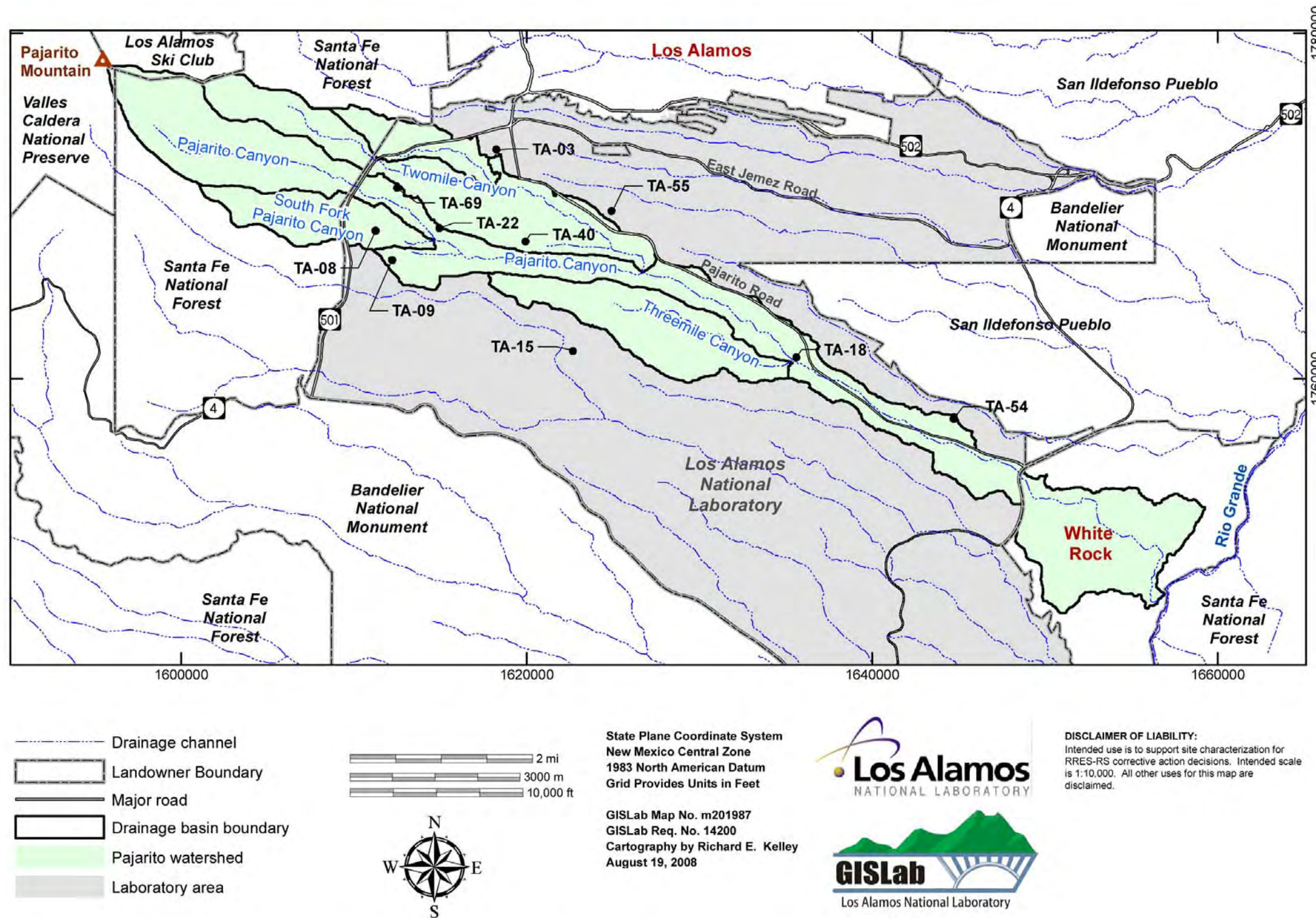

Figure 1.1-1 Pajarito watershed, showing major subbasins

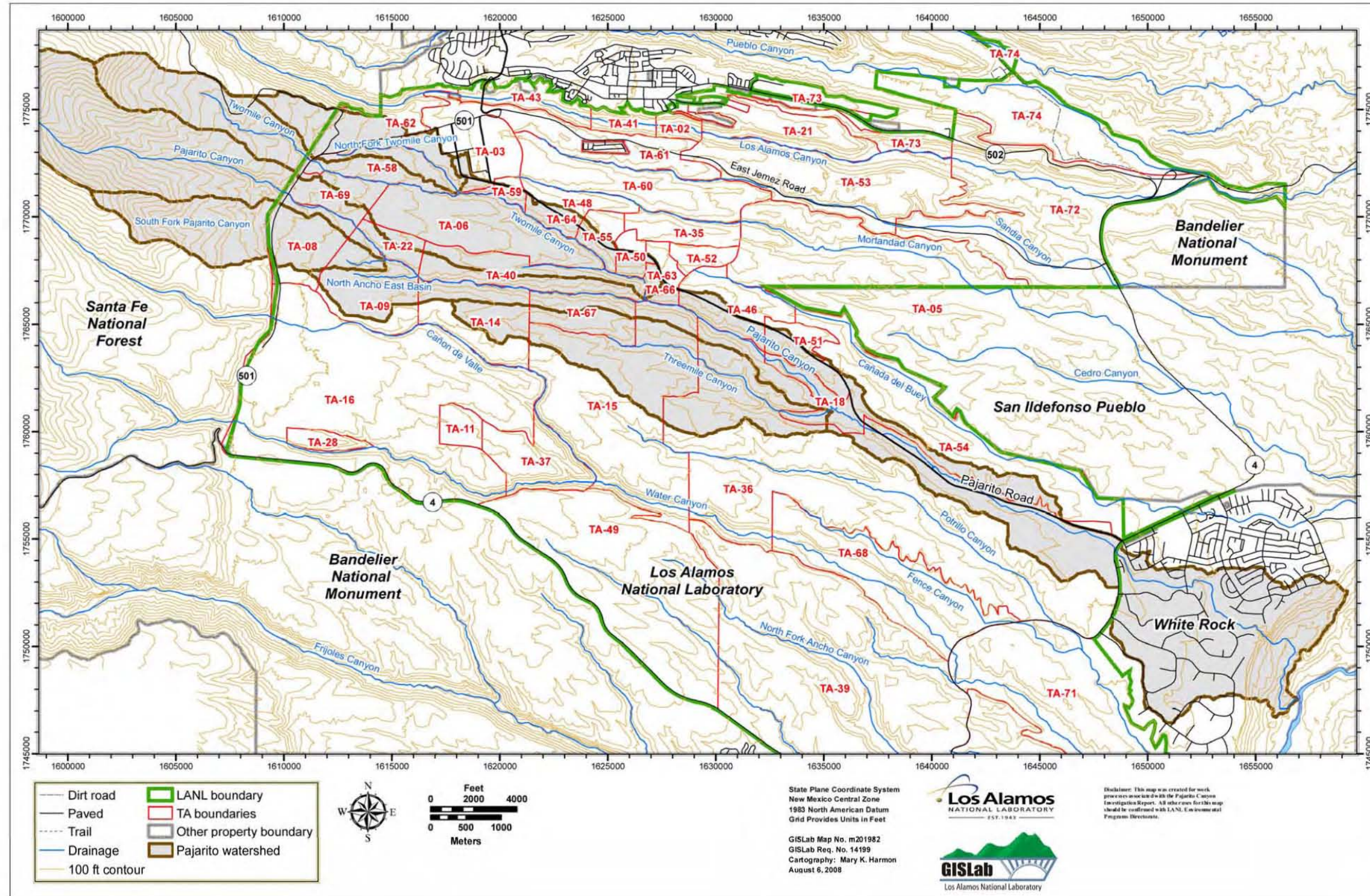

Figure 1.1-2 Pajarito watershed, showing TA boundaries

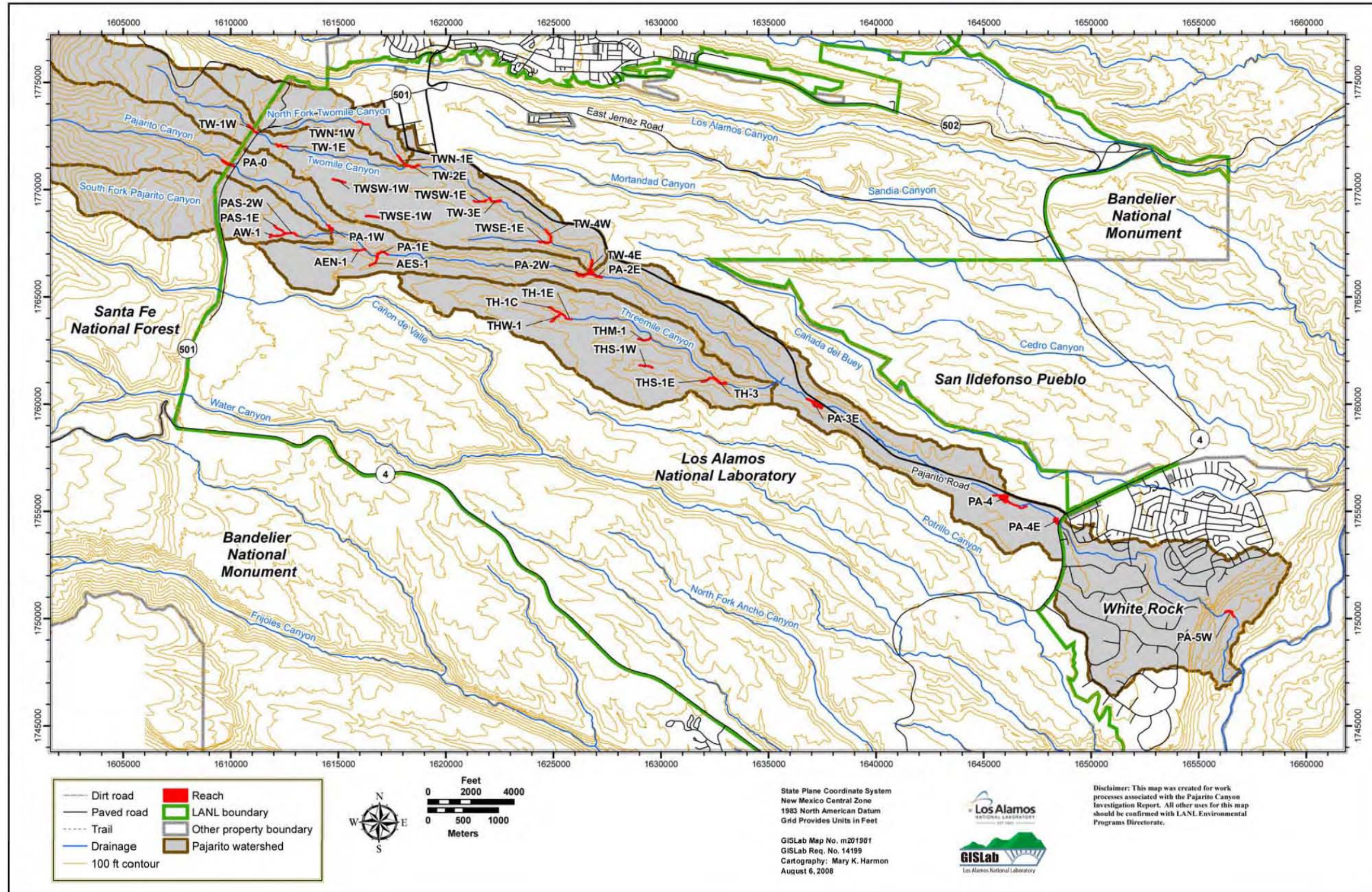

Figure 3.1-1 Sediment investigation reaches in the Pajarito watershed

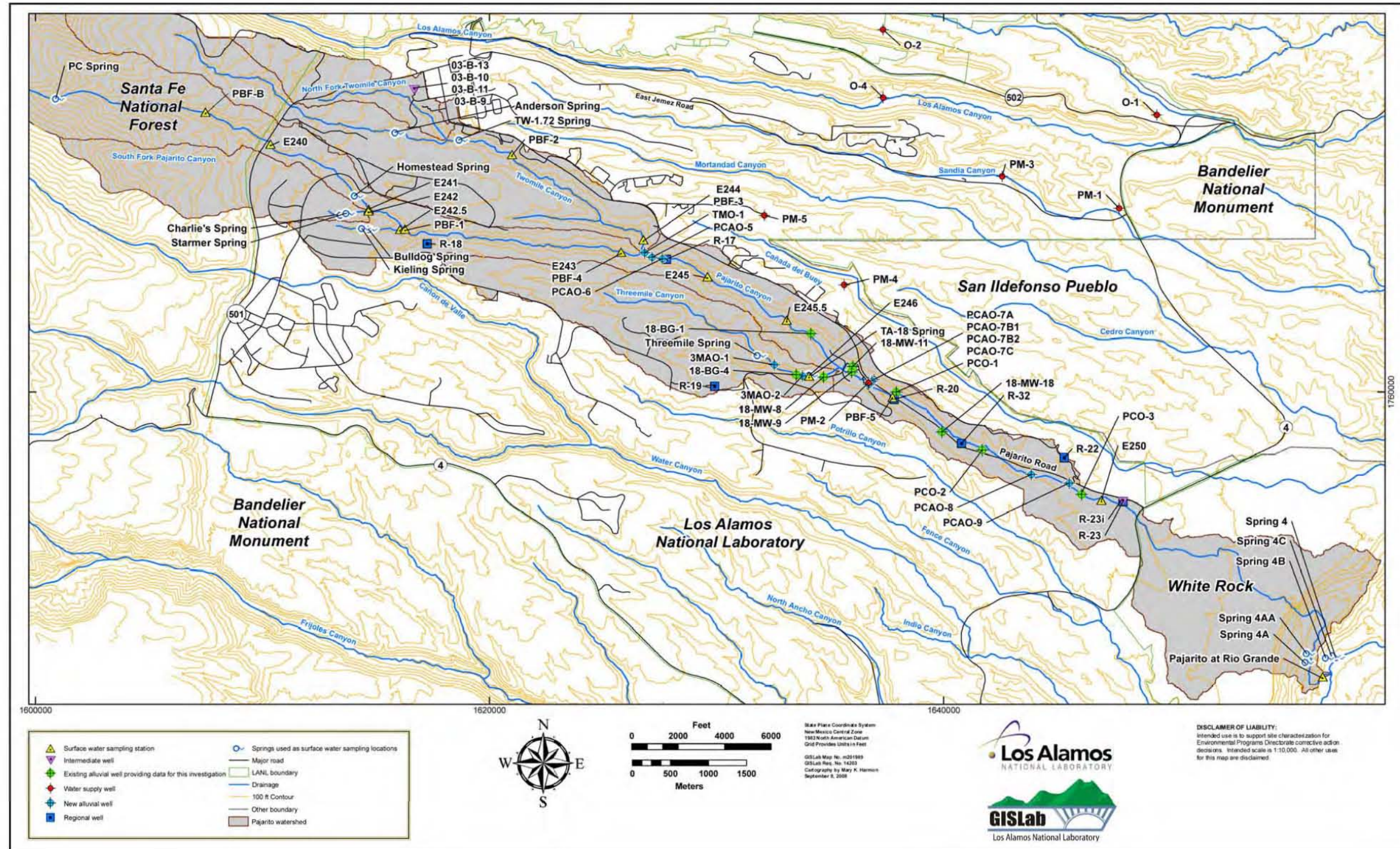

Figure 3.2-1 Water-sampling locations in the Pajarito watershed

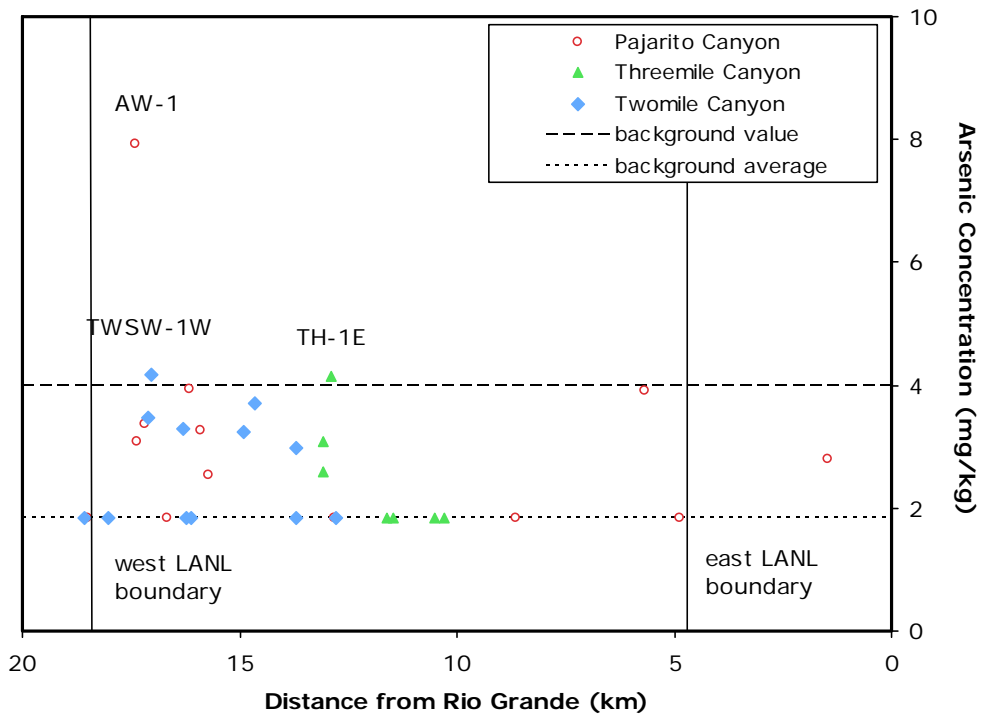
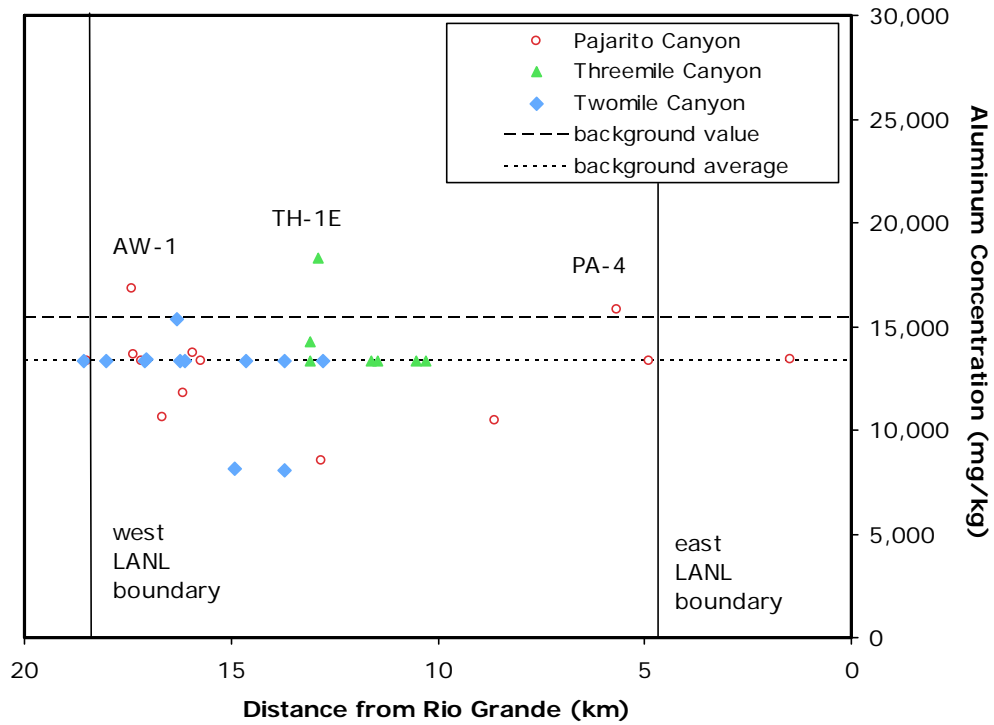

Figure 7.1-1 Estimated average concentrations of select inorganic chemicals in fine facies sediment in the Pajarito watershed. Error bars indicate upper and lower bounds based on replacing nondetect values with either the detection limit or zero, and the background average is plotted where an analyte is not a COPC in a reach.

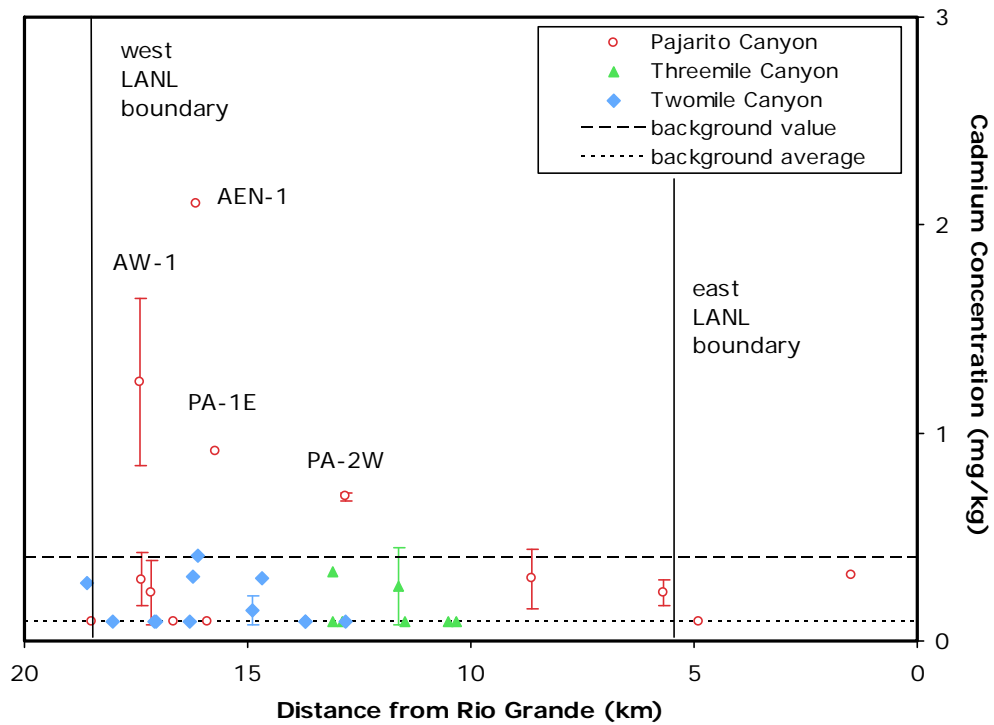
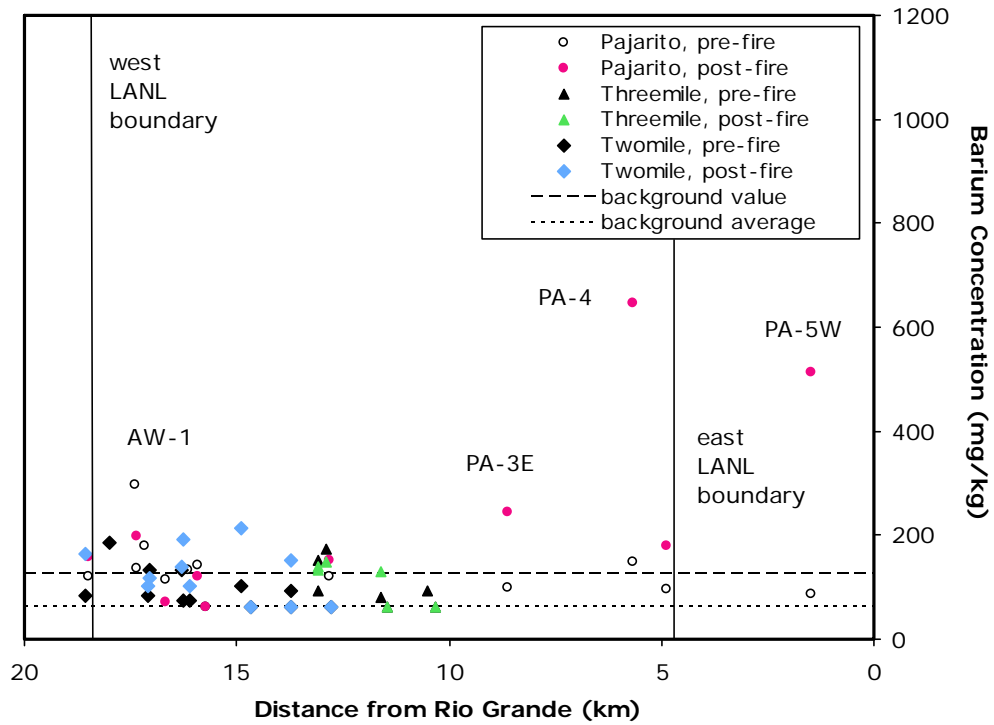

Figure 7.1-1 (continued)

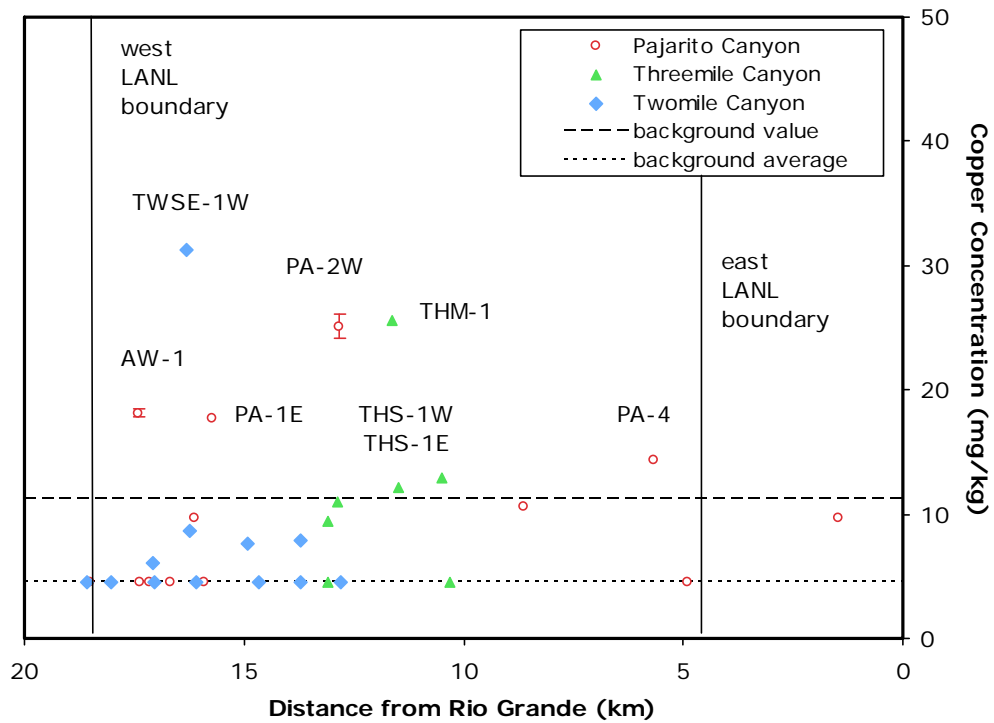
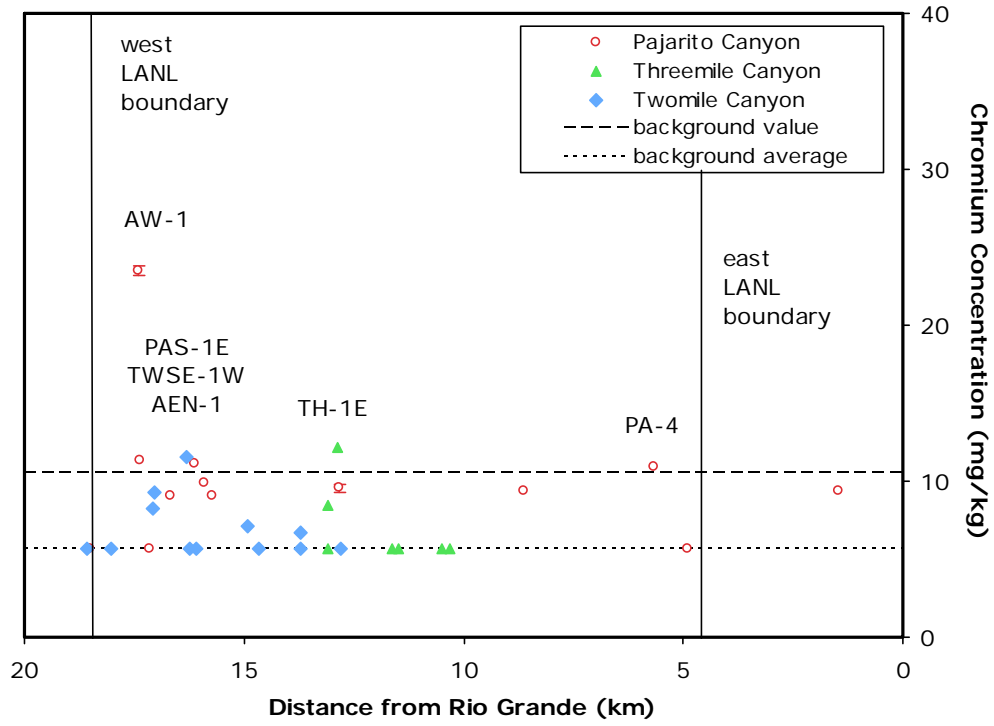

Figure 7.1-1 (continued)

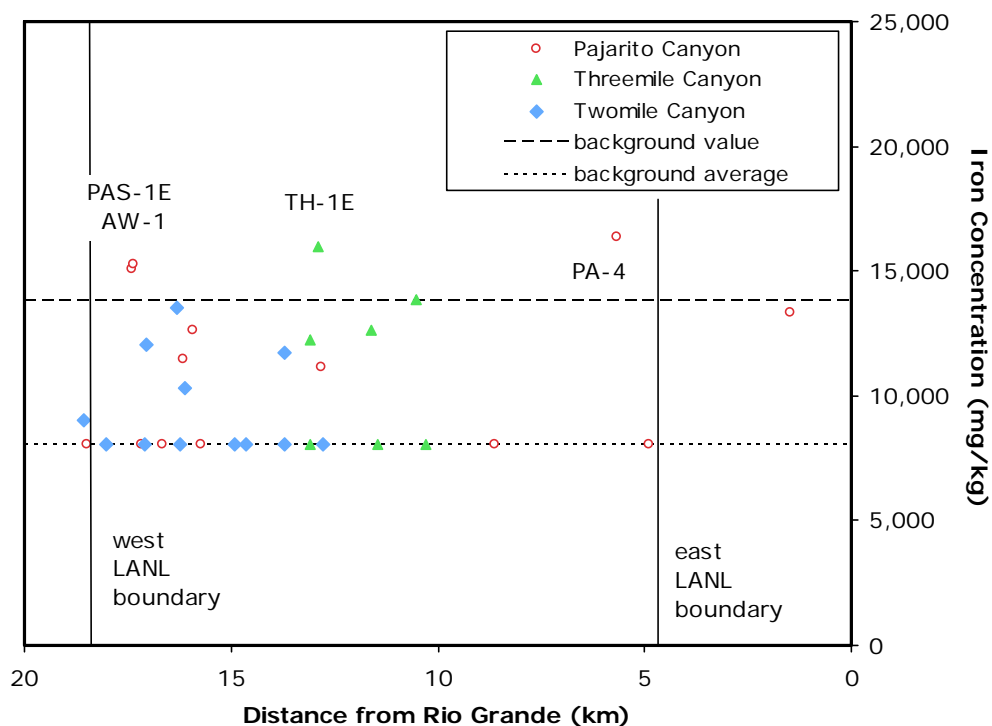
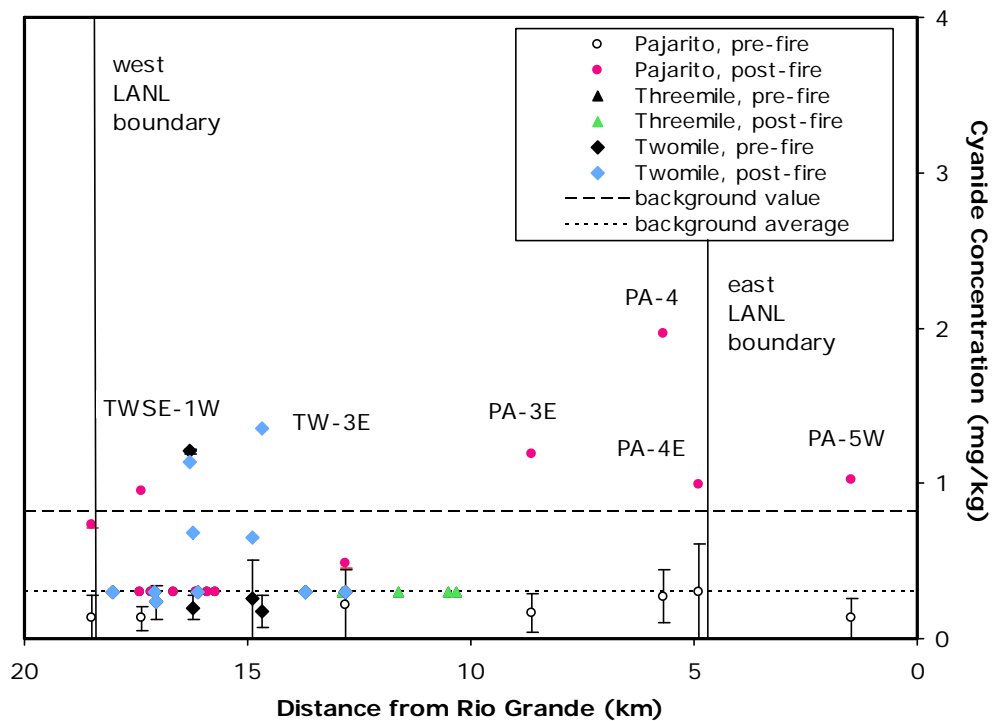

Figure 7.1-1 (continued)

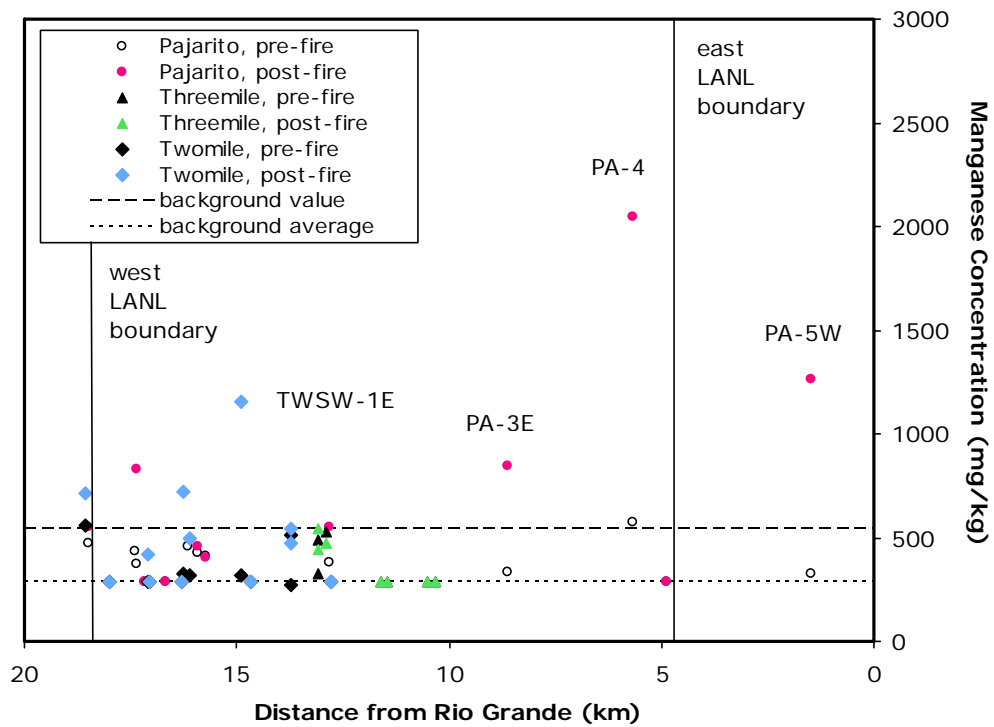
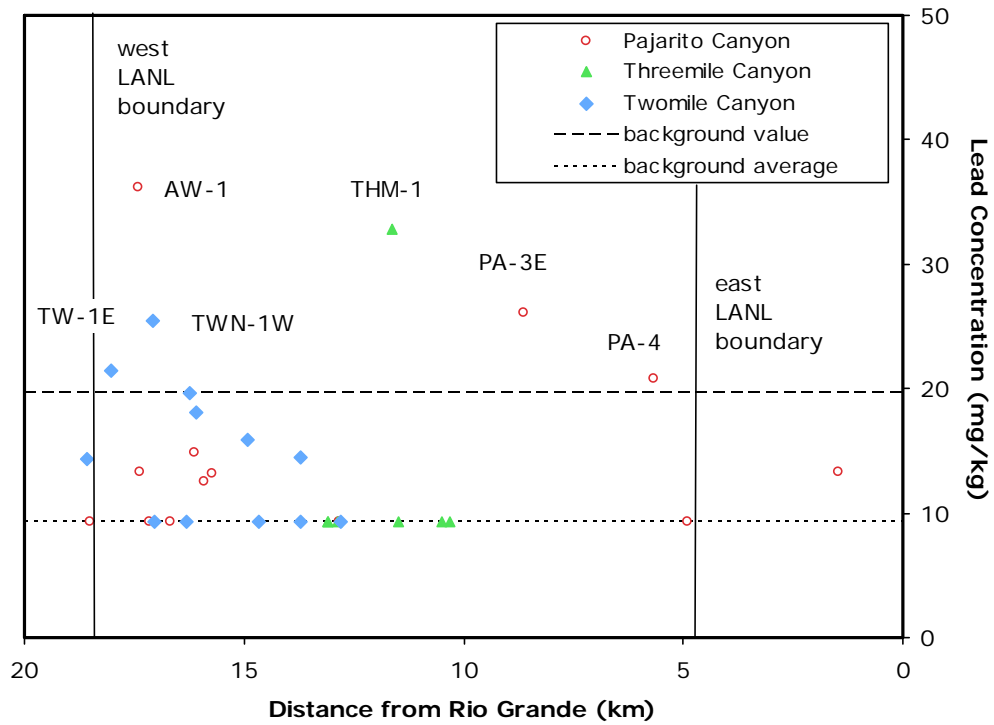

Figure 7.1-1 (continued)

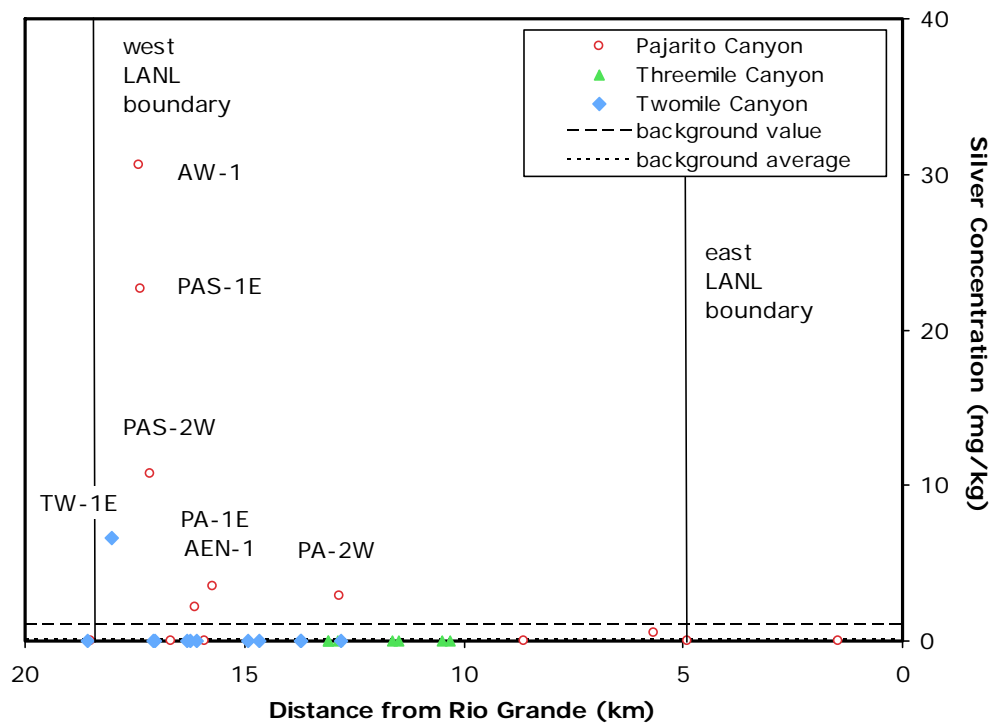
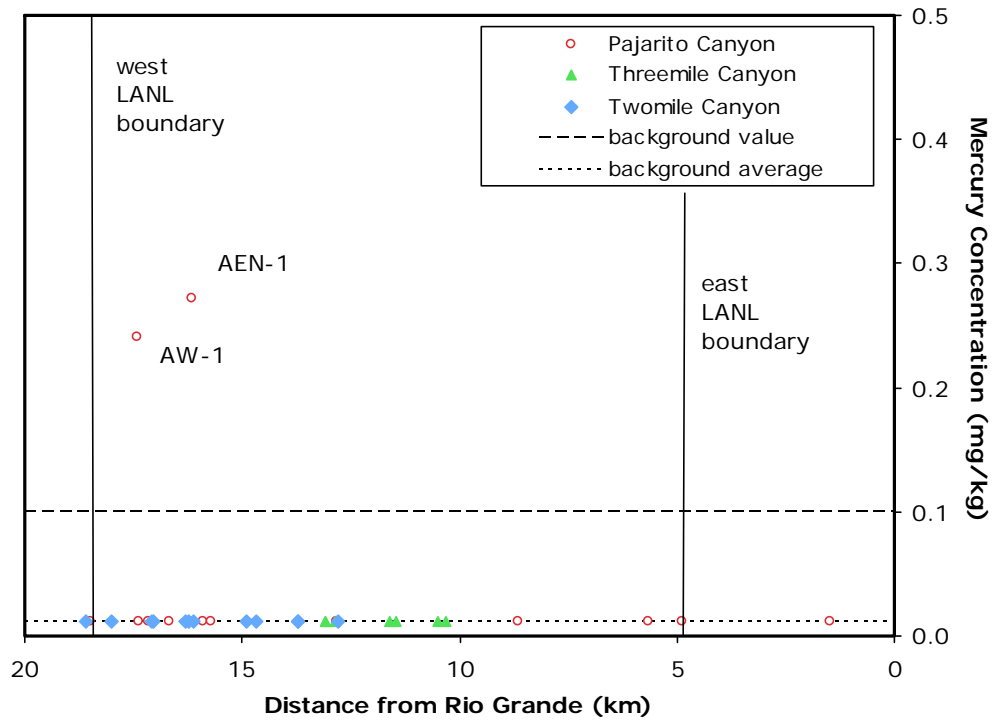

Figure 7.1-1 (continued)

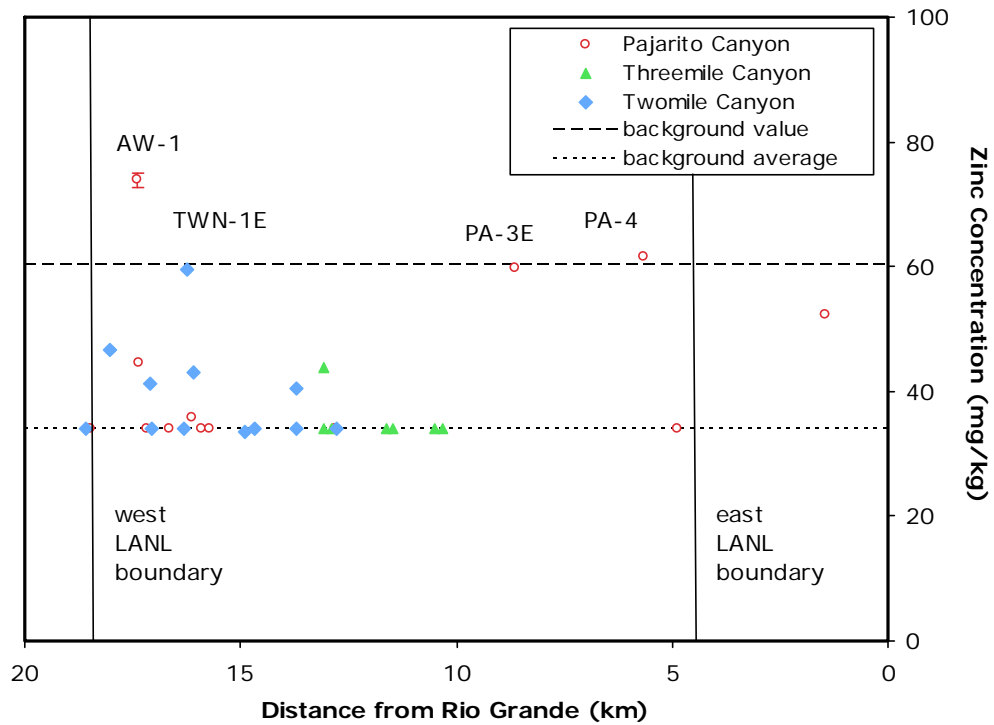
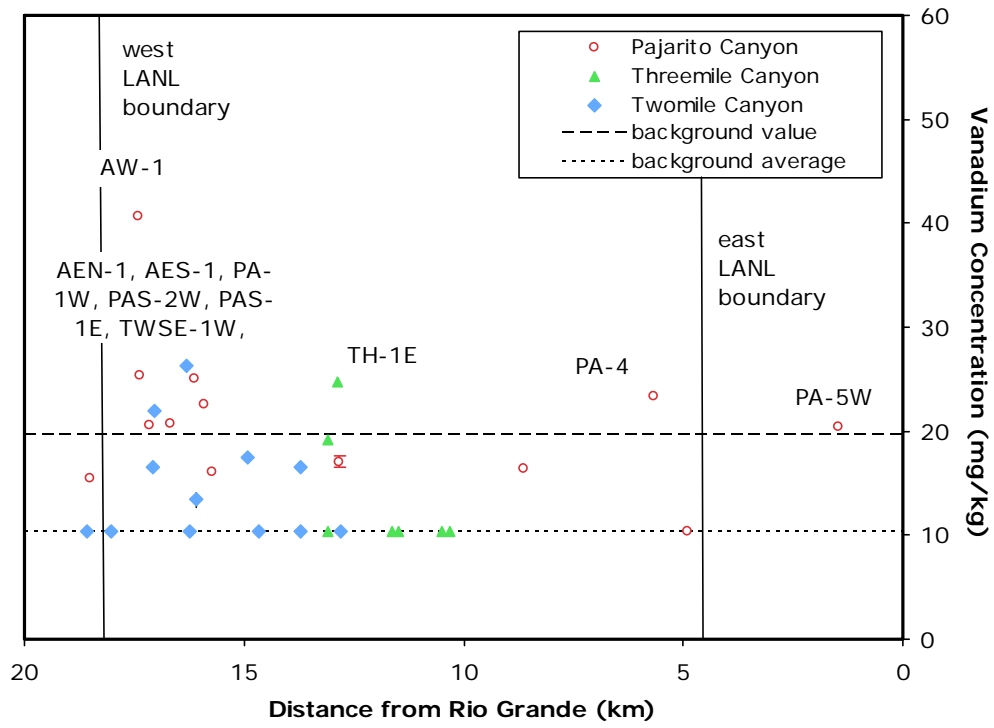

Figure 7.1-1 (continued)

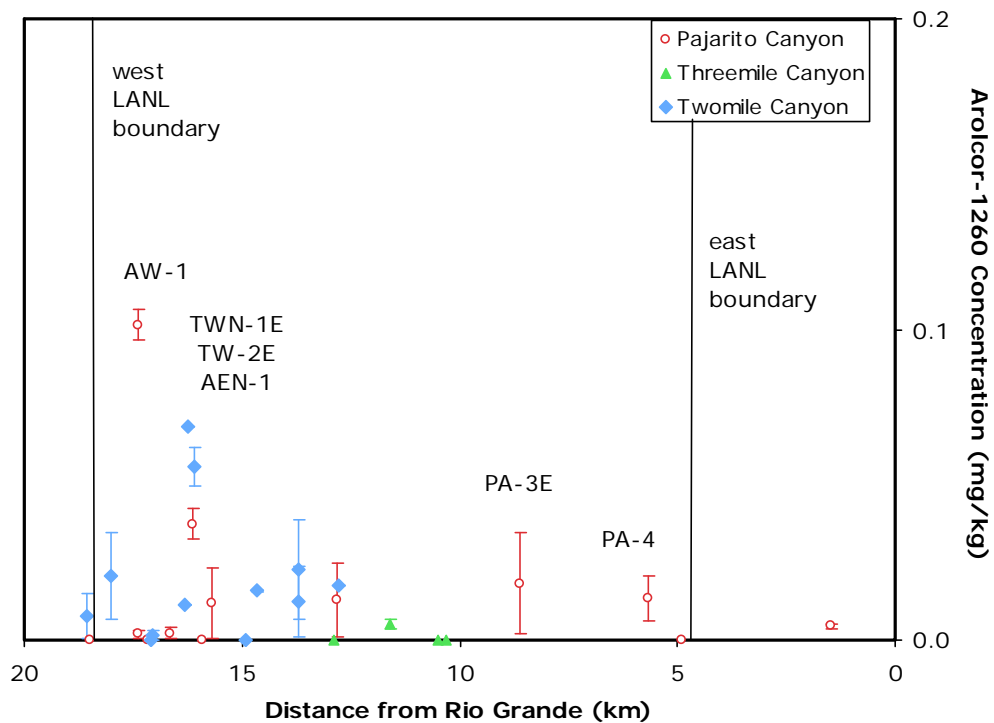
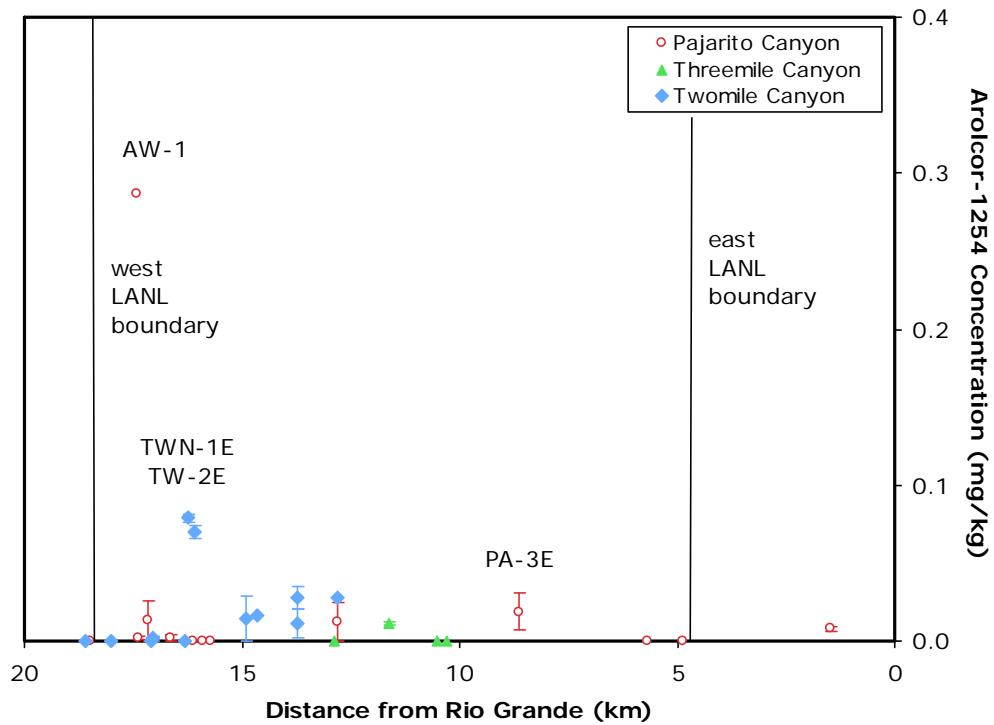

Figure 7.1-2 Estimated average concentrations of select PCBs in fine facies sediment in the Pajarito watershed. Error bars indicate upper and lower bounds based on replacing nondetect values with either the detection limit or zero, and a value of zero is shown where there are no detected results.

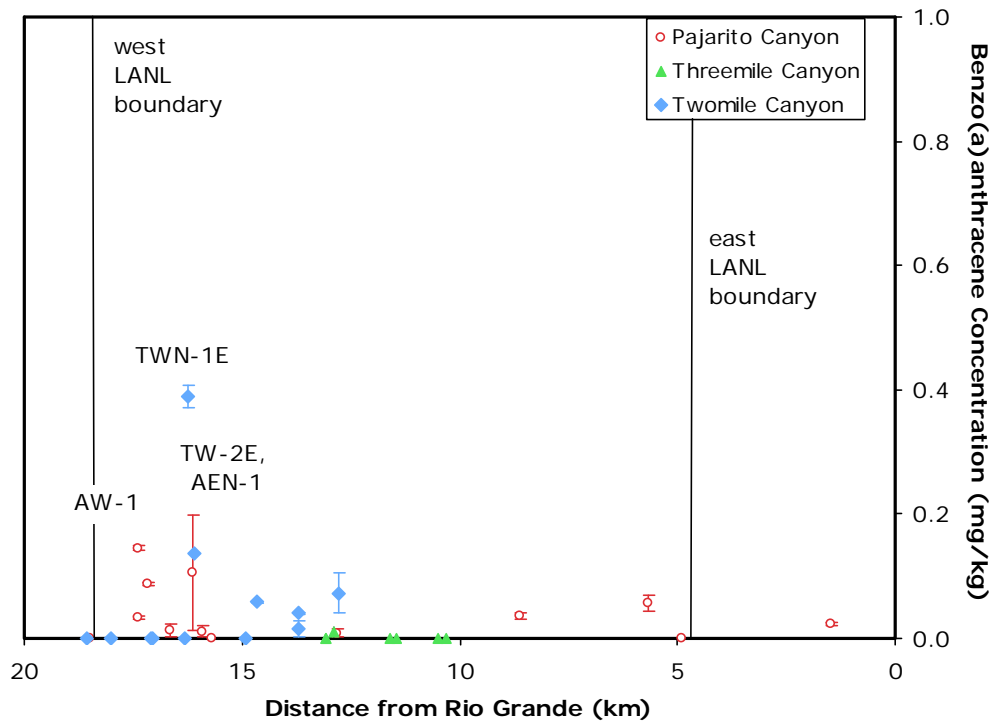
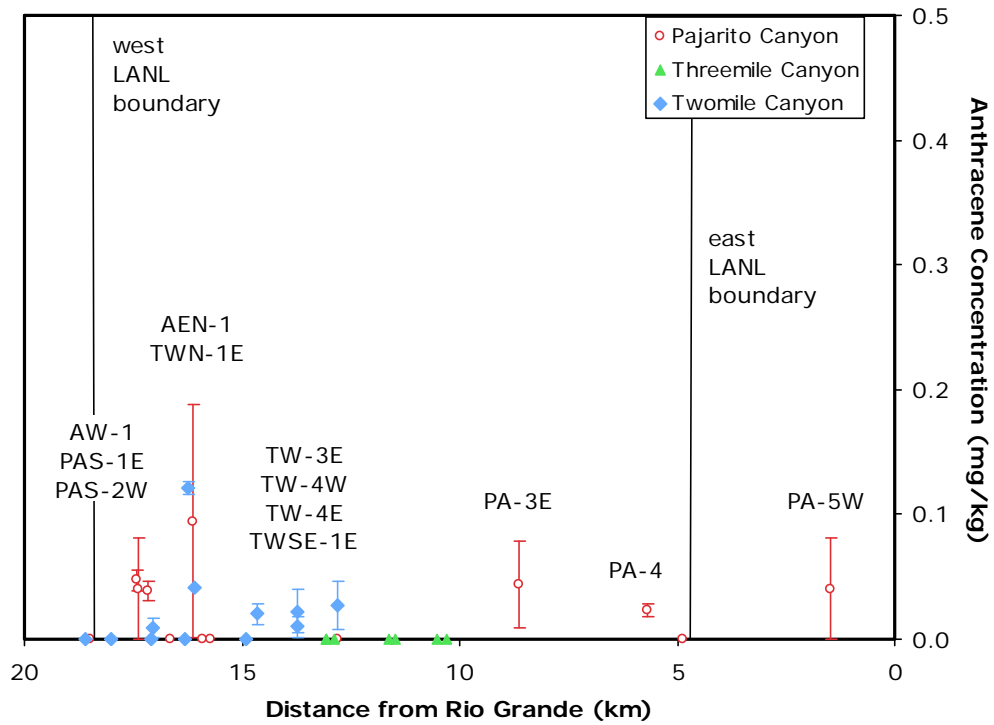

Figure 7.1-3 Estimated average concentrations of select PAHs in fine facies sediment in the Pajarito watershed. Error bars indicate upper and lower bounds based on replacing nondetect values with either the detection limit or zero, and a value of zero is shown where there are no detected results.

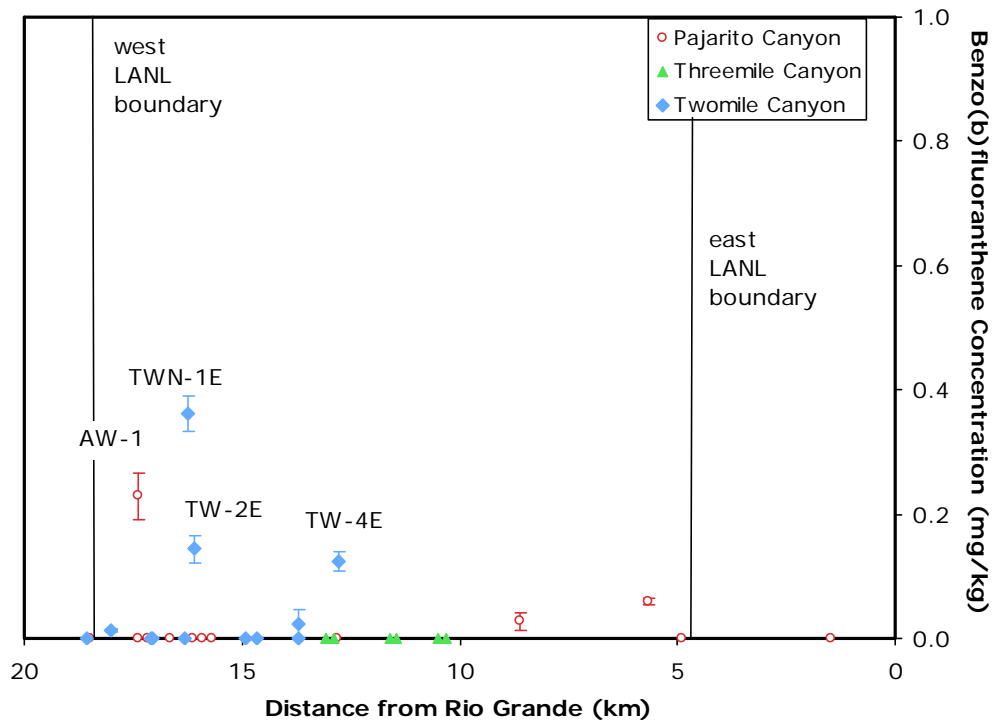
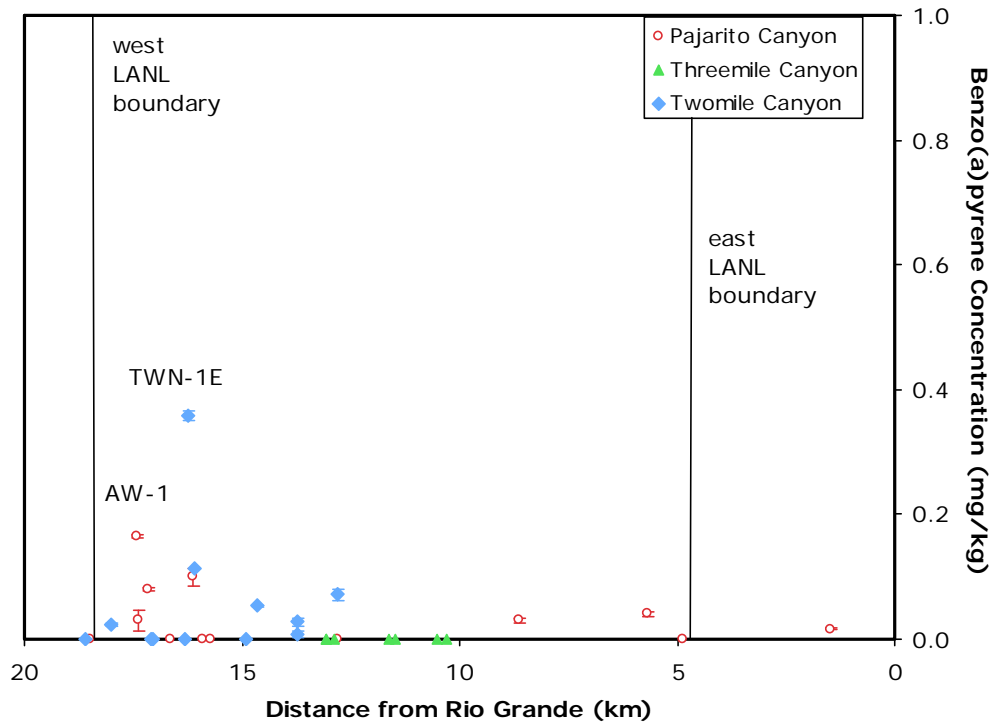

Figure 7.1-3 (continued)

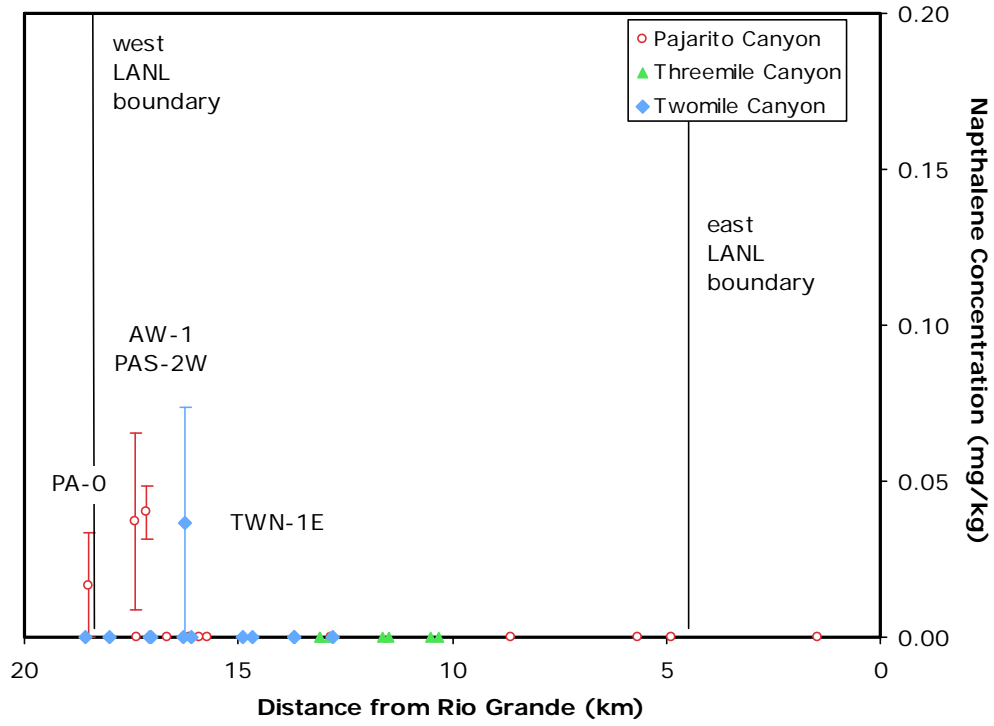

Figure 7.1-3 (continued)

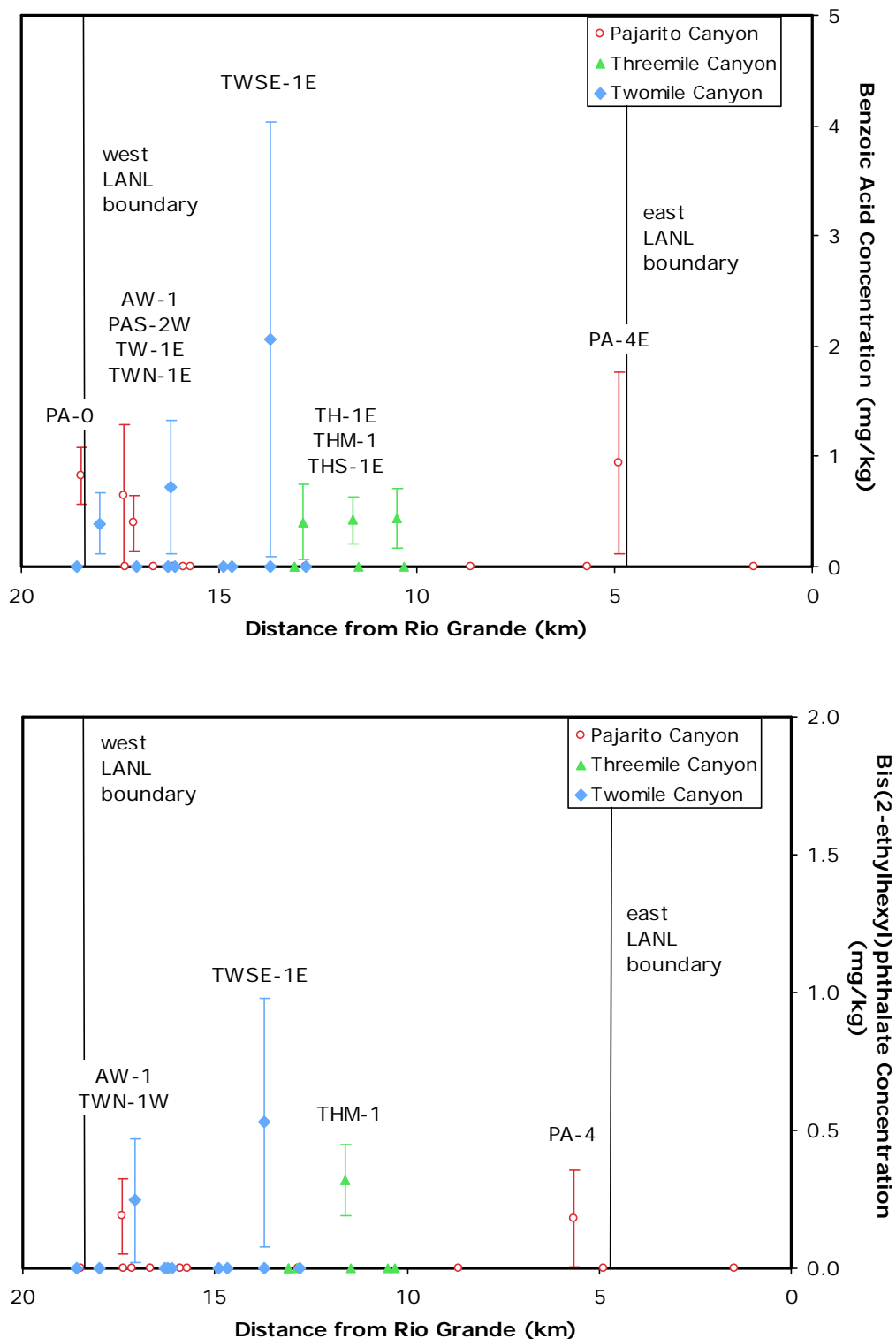

Figure 7.1-4 Estimated average concentrations of select SVOCs in fine facies sediment in the Pajarito watershed. Error bars indicate upper and lower bounds based on replacing nondetect values with either the detection limit or zero, and a value of zero is shown where there are no detected results.

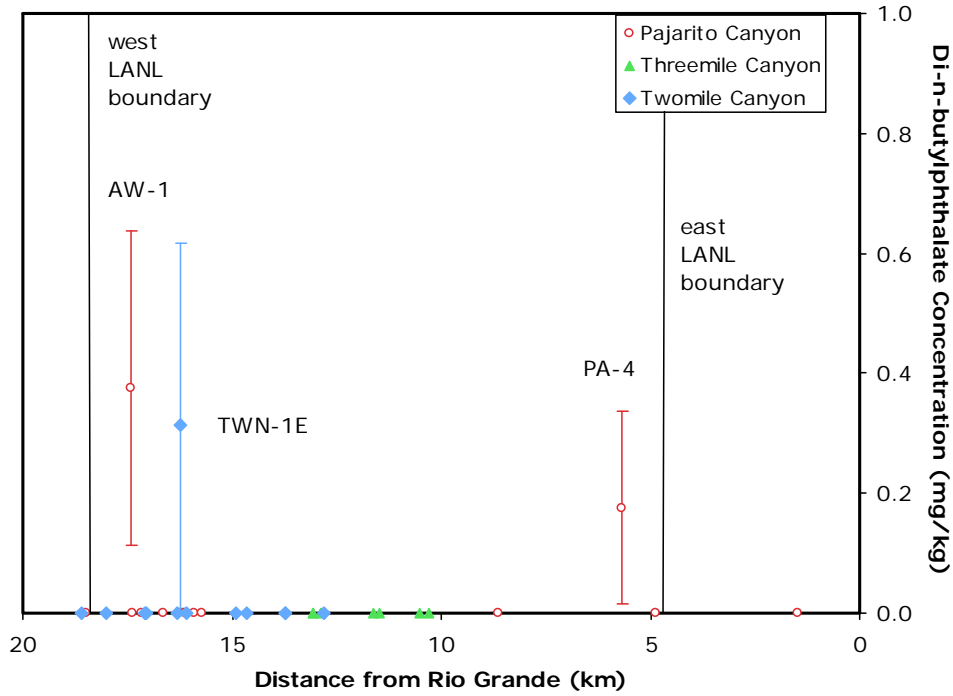

Figure 7.1-4 (continued)

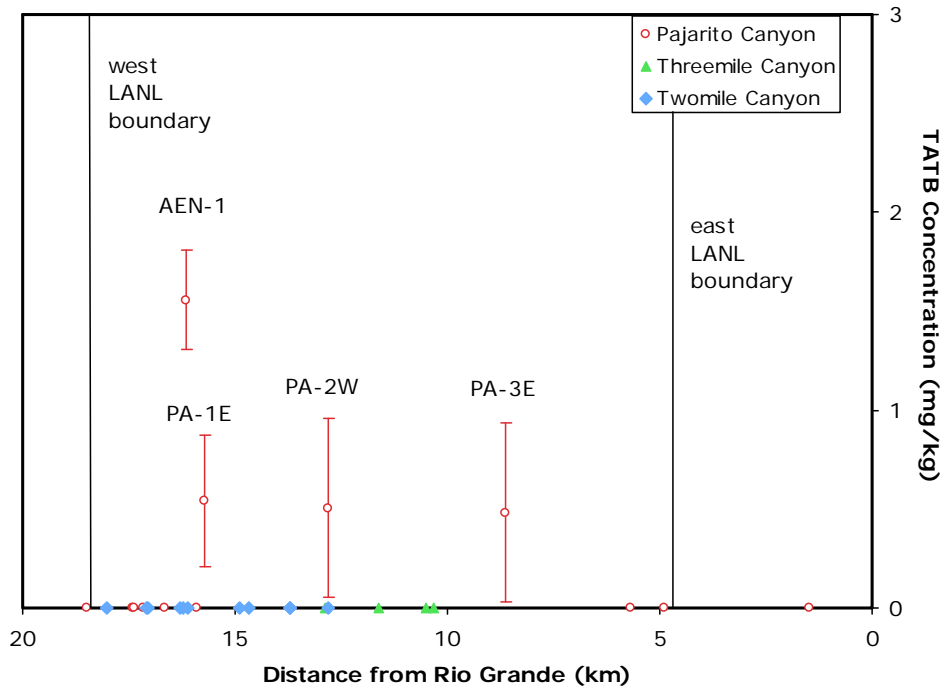

Figure 7.1-5 Estimated average concentrations of the explosive compound TATB in fine facies sediment in the Pajarito watershed. Error bars indicate upper and lower bounds based on replacing nondetect values with either the detection limit or zero.

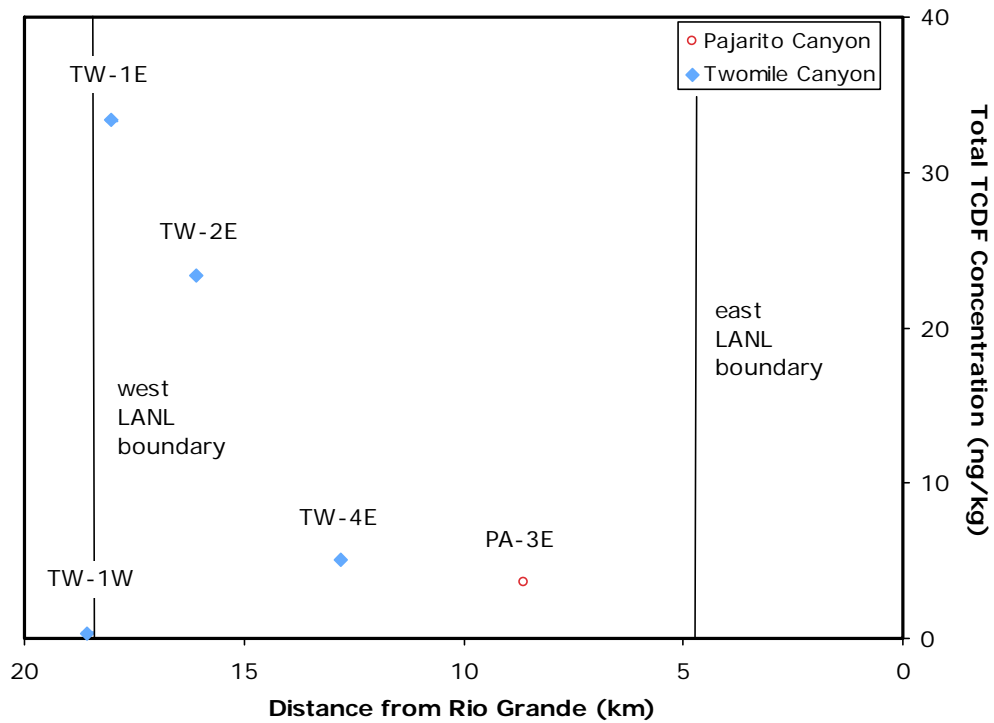
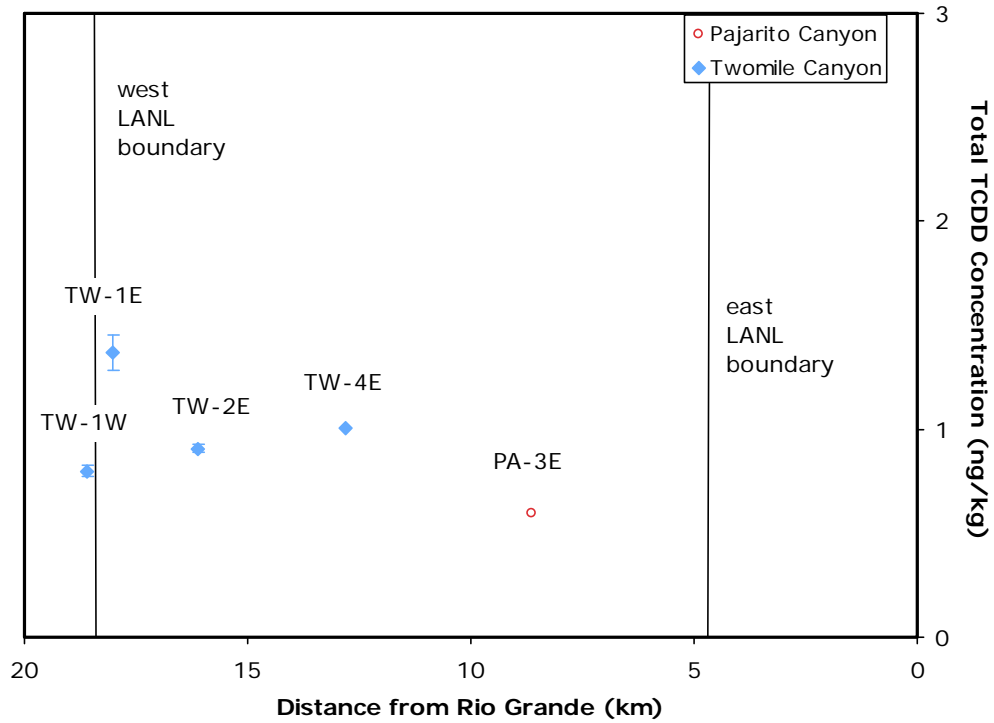

Figure 7.1-6 Estimated average concentrations of select dioxins and furans in fine facies sediment in the Pajarito watershed. Error bars indicate upper and lower bounds based on replacing nondetect values with either the detection limit or zero.

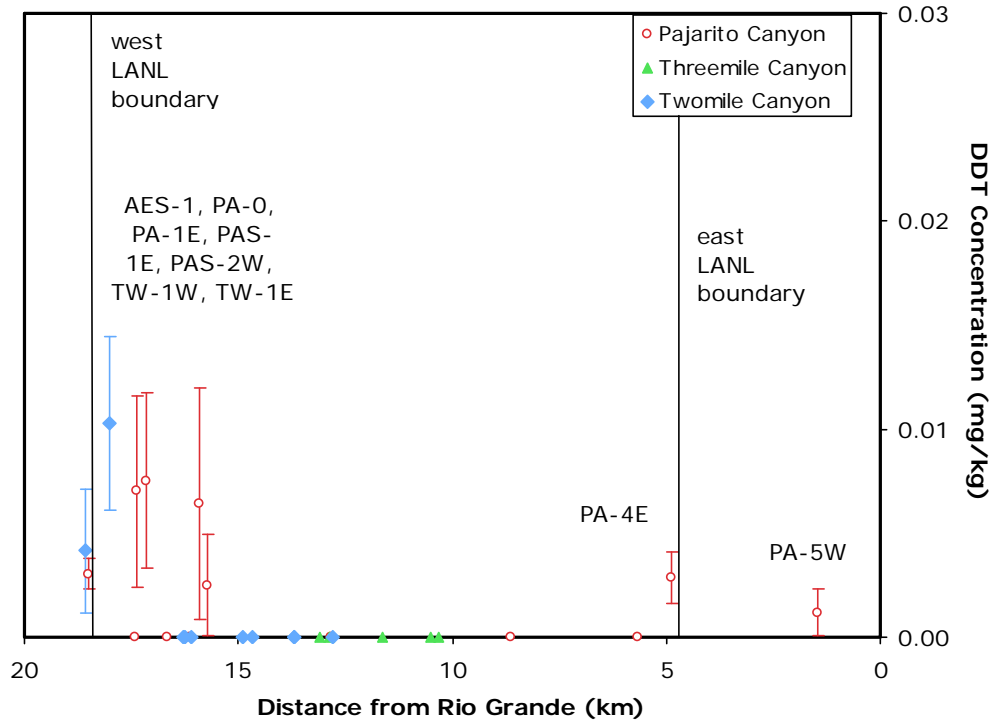

Figure 7.1-7 Estimated average concentrations of the pesticide DDT in fine facies sediment in the Pajarito watershed. Error bars indicate upper and lower bounds based on replacing nondetect values with either the detection limit or zero.

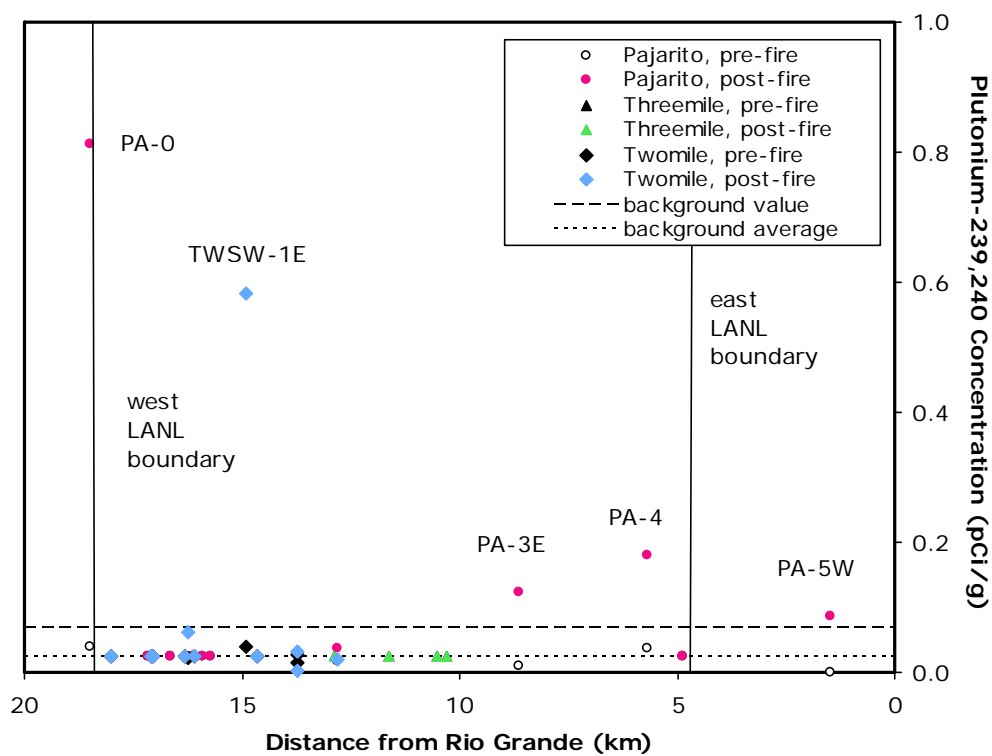
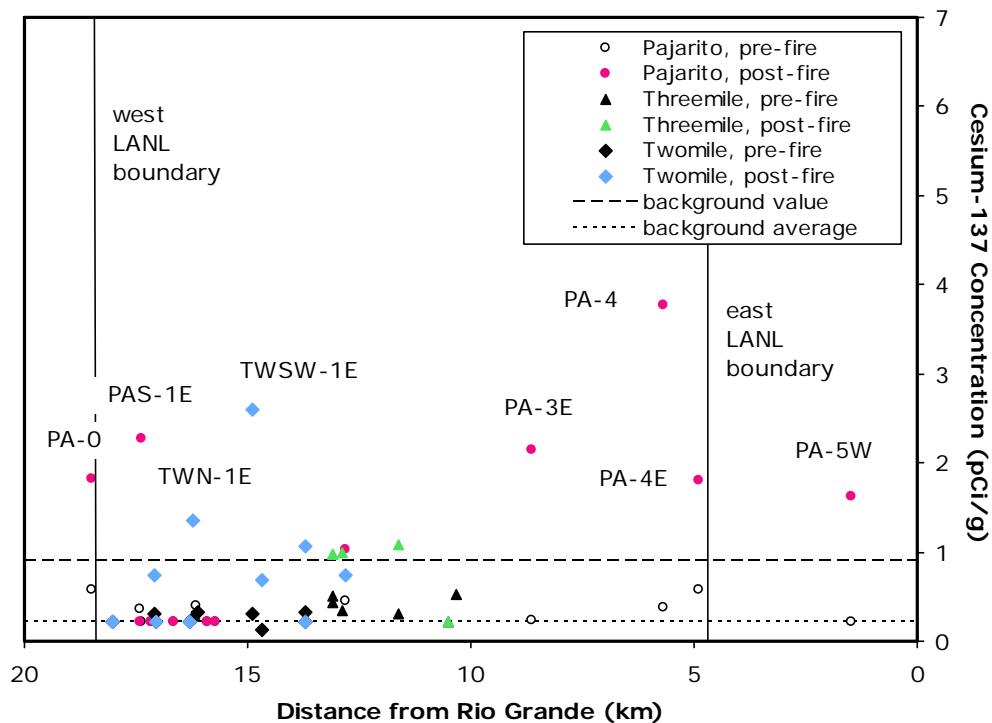

Figure 7.1-8 Estimated average concentrations of cesium-137 and plutonium-239,240 in fine facies sediment in the Pajarito watershed; value shown as the average background concentration in reaches where these radionuclides are not COPCs.

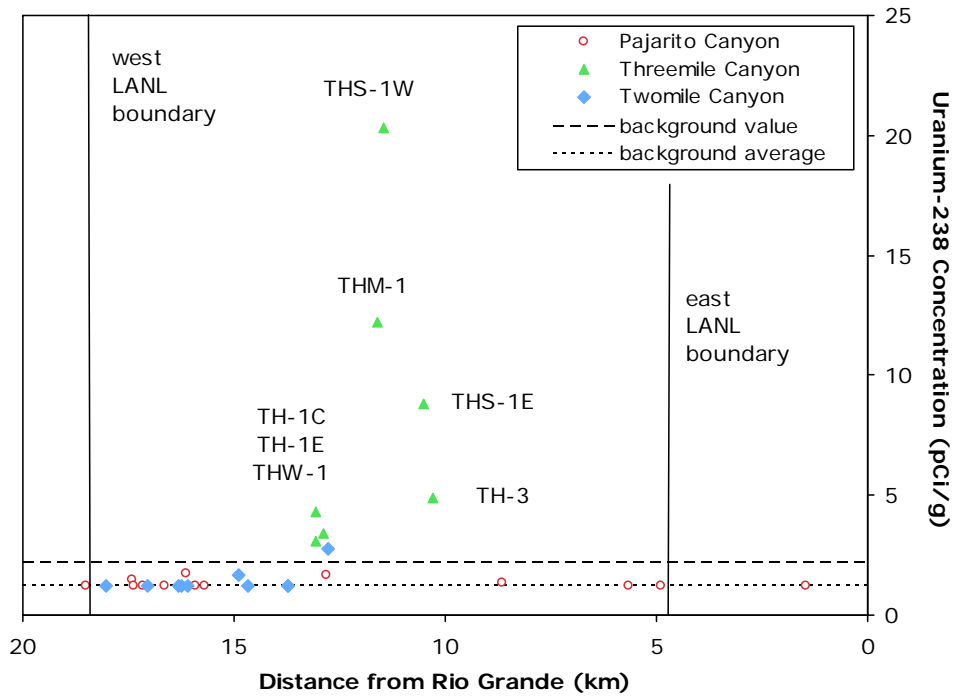

Figure 7.1-9 Estimated average concentrations of uranium-238 in fine facies sediment in the Pajarito watershed; value shown as the average background concentration in reaches where uranium-238 is not a COPC.

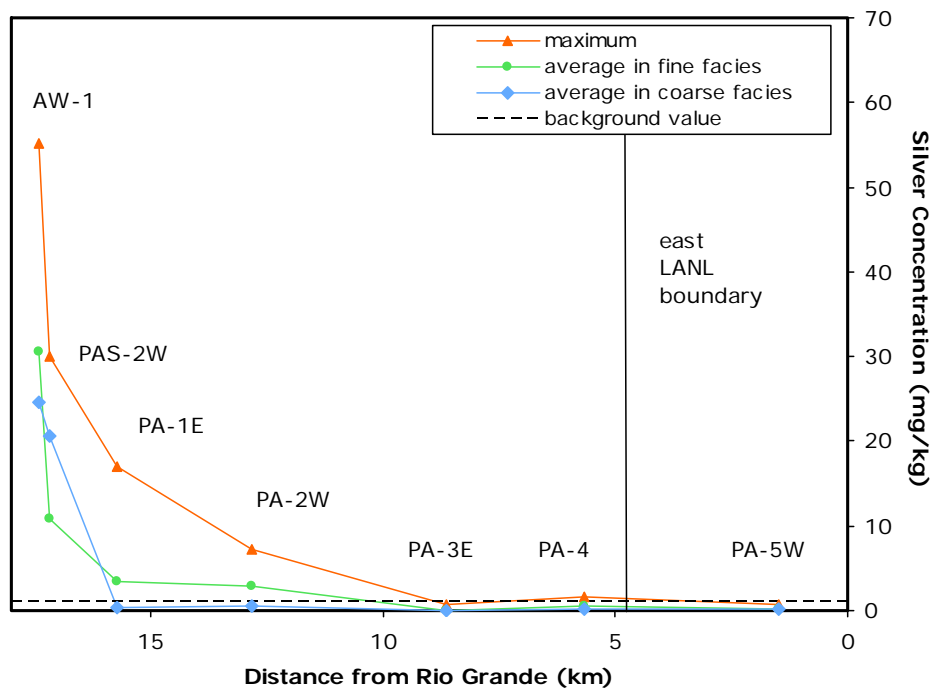

Figure 7.1-10 Spatial variations in silver concentration between TA-08 (reach AW-1) and the Rio Grande

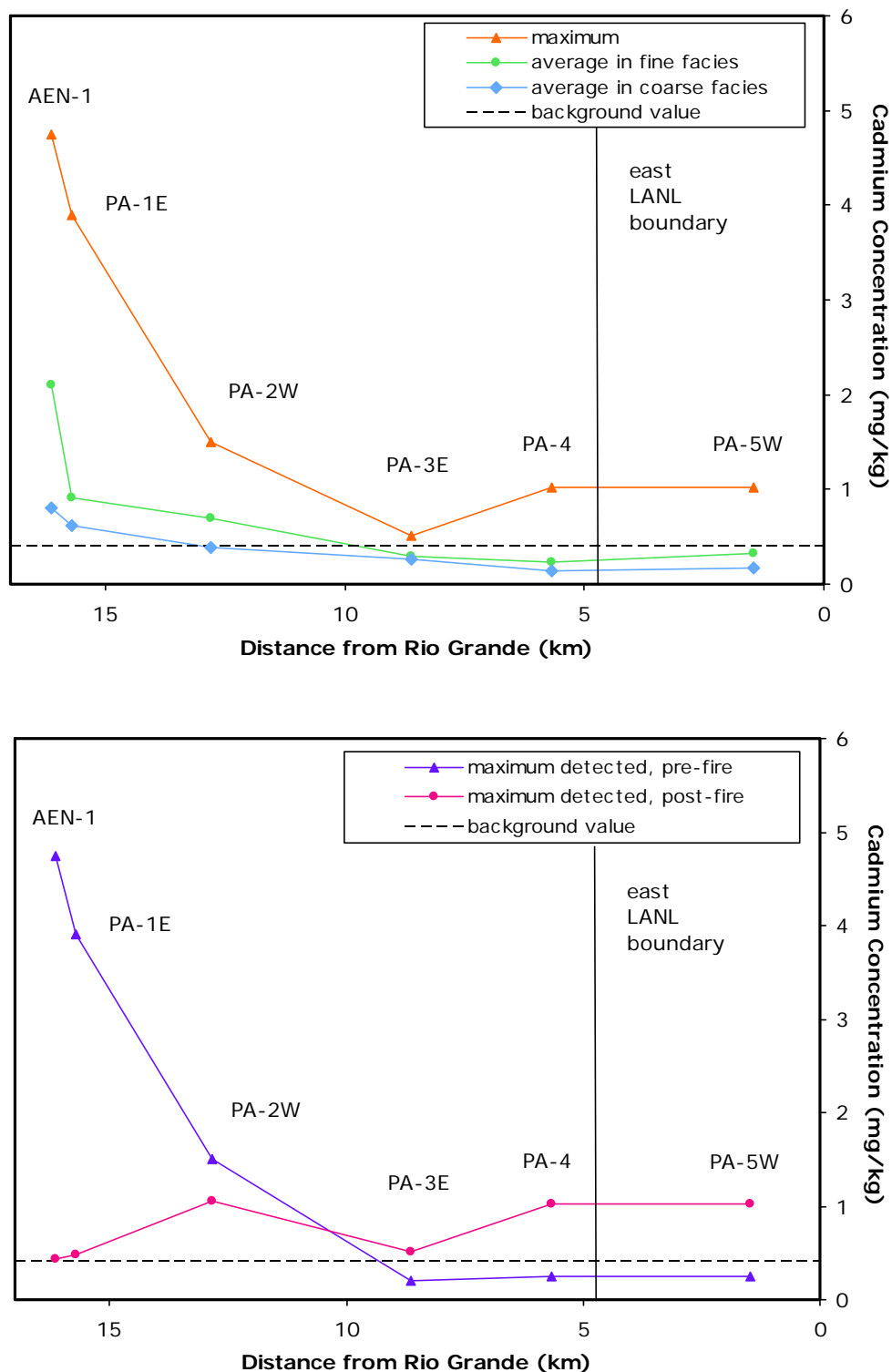

Figure 7.1-11 Spatial variations in cadmium concentration between TA-09 (reach AEN-1) and the Rio Grande; upper plot shows maximum concentrations and averages in fine and coarse facies sediment in each reach; lower plot compares maximum in pre-fire and post-fire sediment.

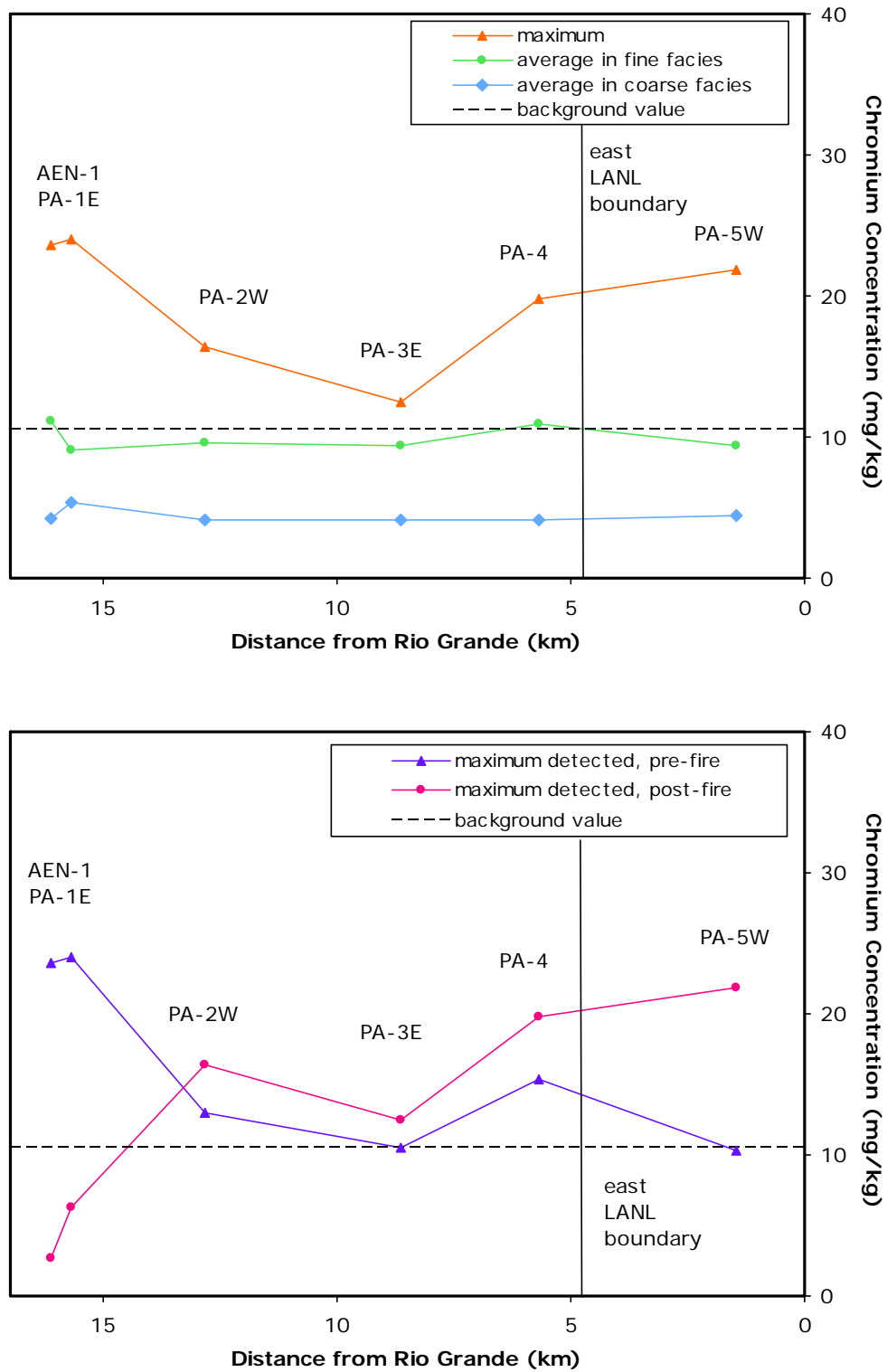

Figure 7.1-12 Spatial variations in chromium concentration between TA-09 (reach AEN-1) and the Rio Grande; upper plot shows maximum concentrations and averages in fine and coarse facies sediment in each reach; lower plot compares maximum in pre-fire and post-fire sediment.

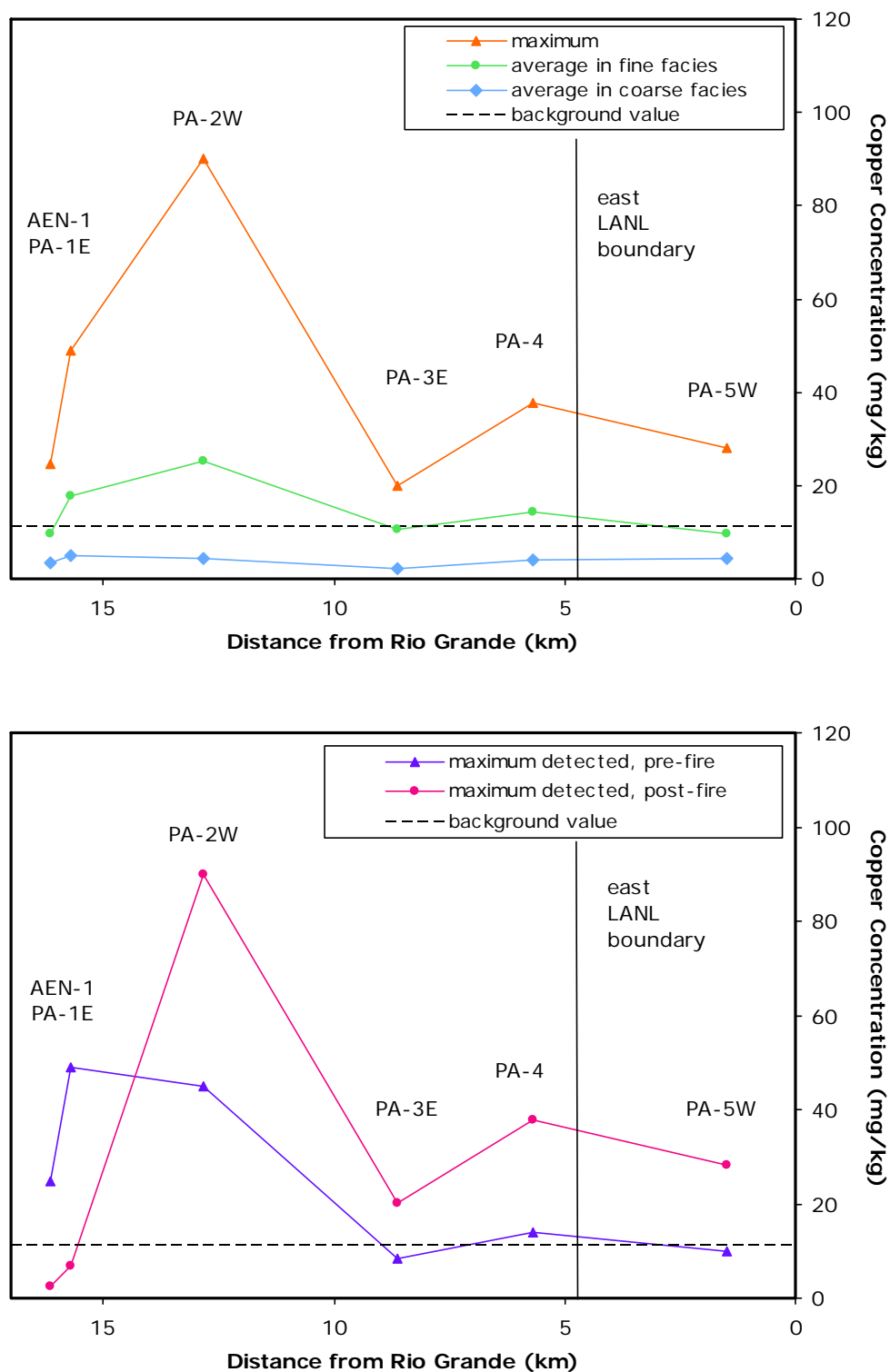

Figure 7.1-13 Spatial variations in copper concentration between TA-09 (reach AEN-1) and the Rio Grande; upper plot shows maximum concentrations and averages in fine and coarse facies sediment in each reach; lower plot compares maximum in pre-fire and post-fire sediment.

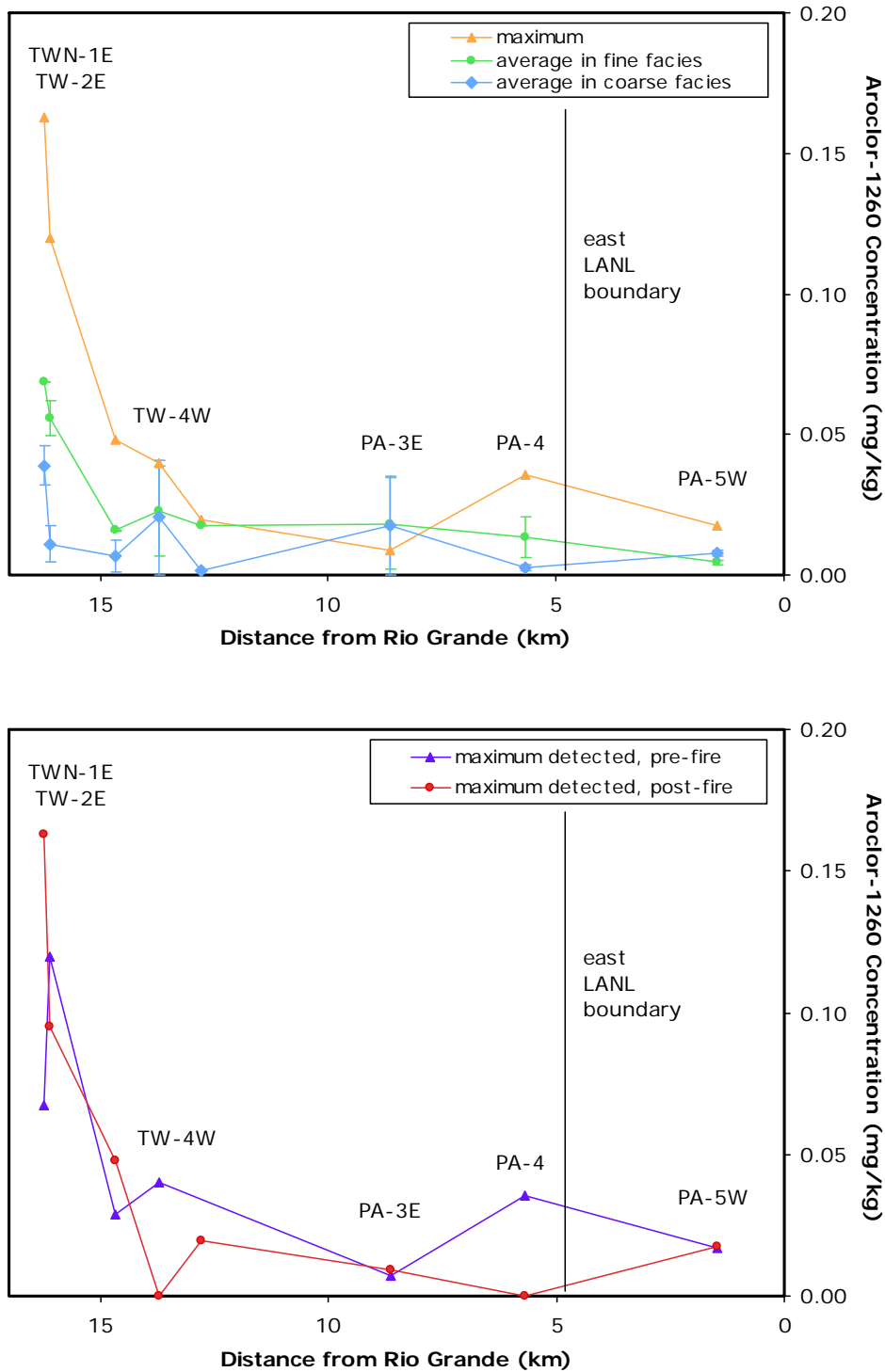

Figure 7.1-14 Spatial variations Aroclor-1260 concentration between TA-03 (reach TWN-1E) and the Rio Grande; upper plot shows maximum concentrations and averages in fine and coarse facies sediment in each reach; lower plot compares maximum in pre-fire and post-fire sediment. Error bars indicate upper and lower bounds based on replacing nondetect values with either the detection limit or zero.

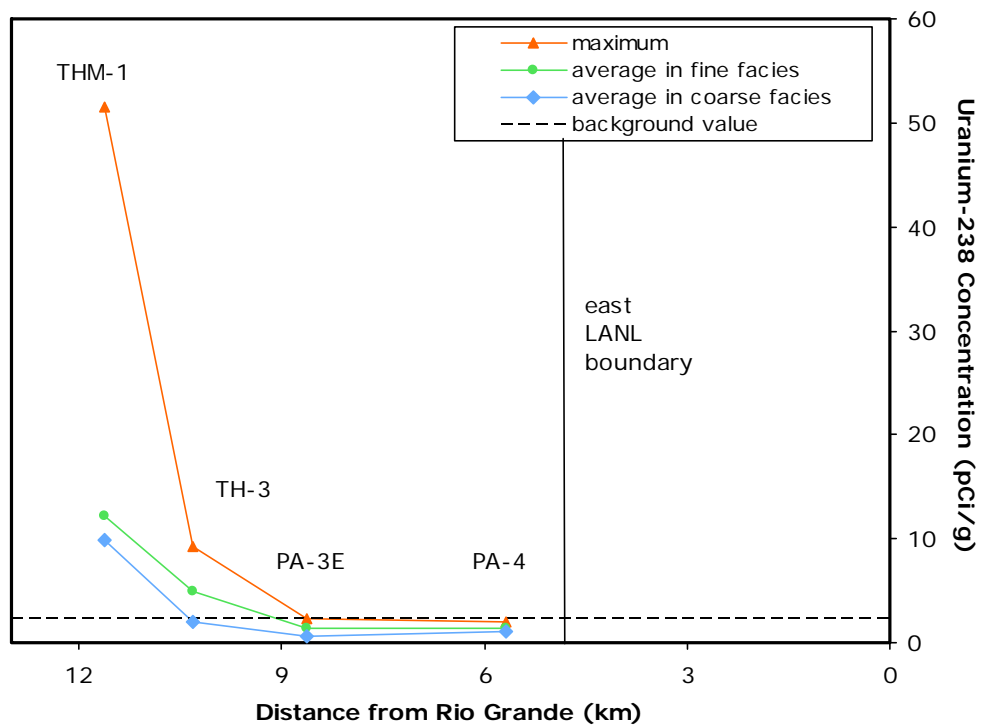
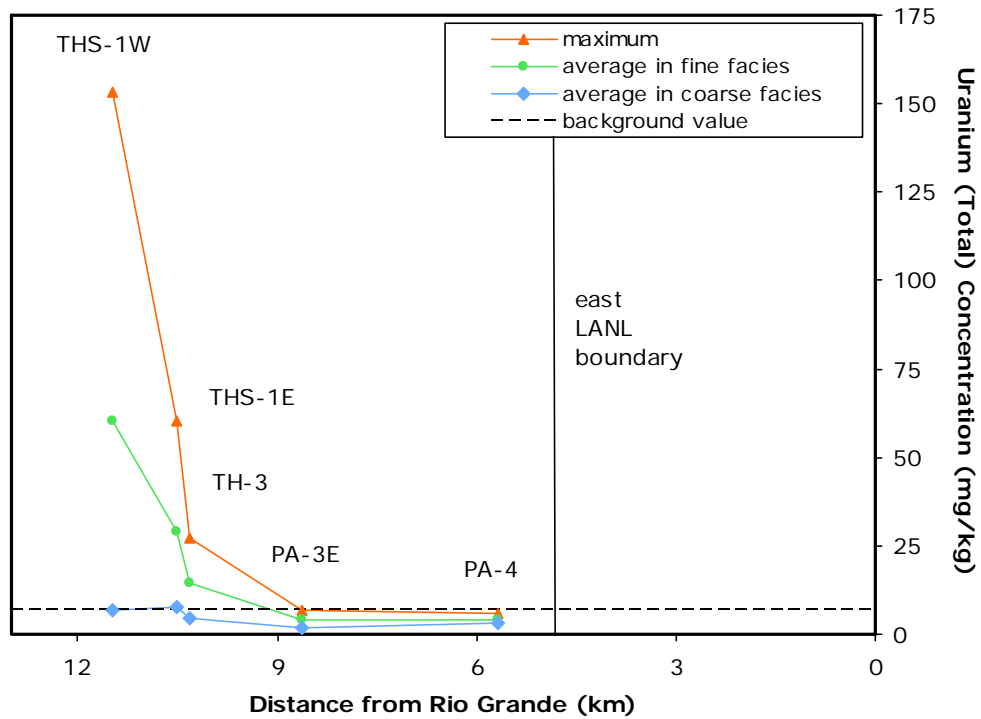

Figure 7.1-15 Spatial variations in total uranium and uranium-238 concentration between TA-15 firing sites (reaches THM-1 and THS-1W) and the Rio Grande

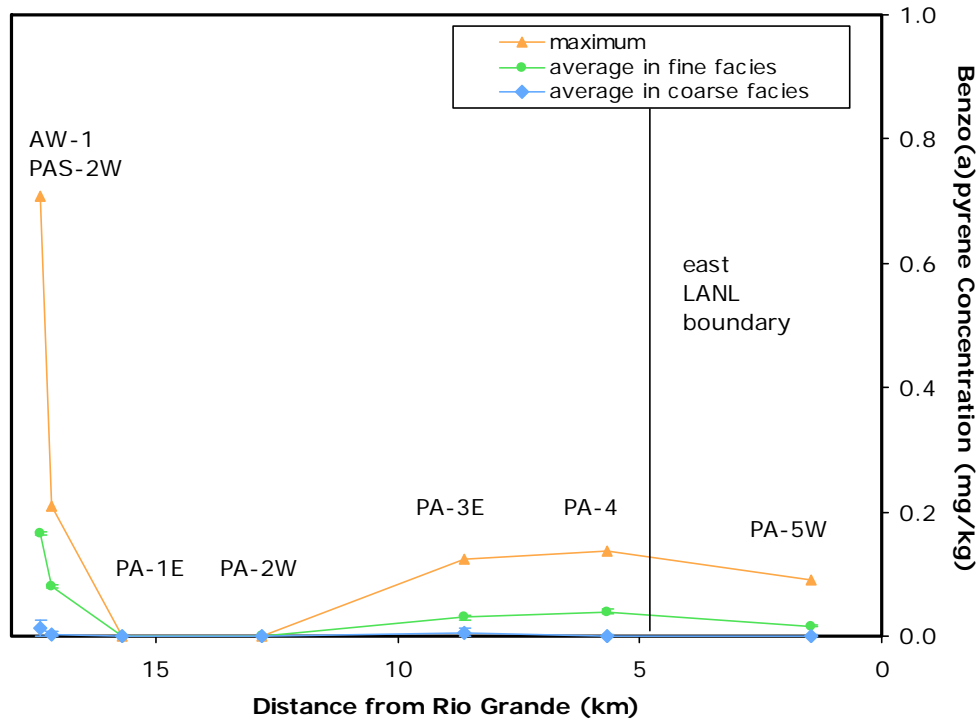
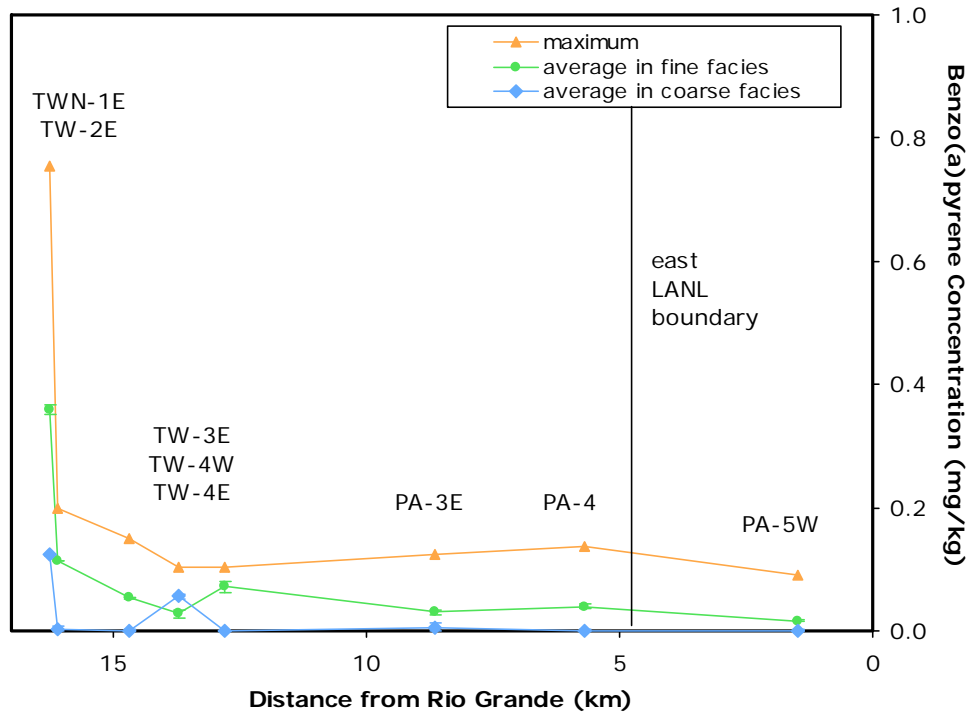

Figure 7.1-16 Plot of uranium-238 vs. uranium-235 concentrations in Threemile Canyon sediment samples; the red line indicates values expected in natural uranium, and values plotting below the line indicate depleted uranium.

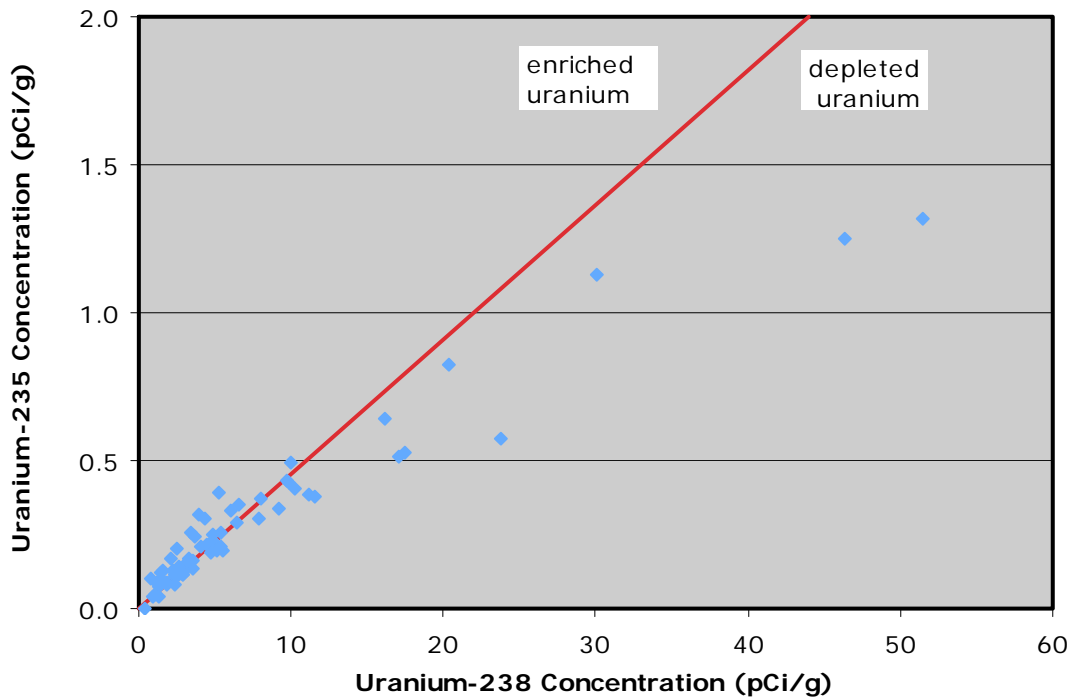

Figure 7.1-17 Spatial variations in benzo(a)pyrene concentration between TA-03 (reach TWN-1E) and TA-08 (reach AW-1) and the Rio Grande. Error bars indicate upper and lower bounds based on replacing nondetect values with either the detection limit or zero.

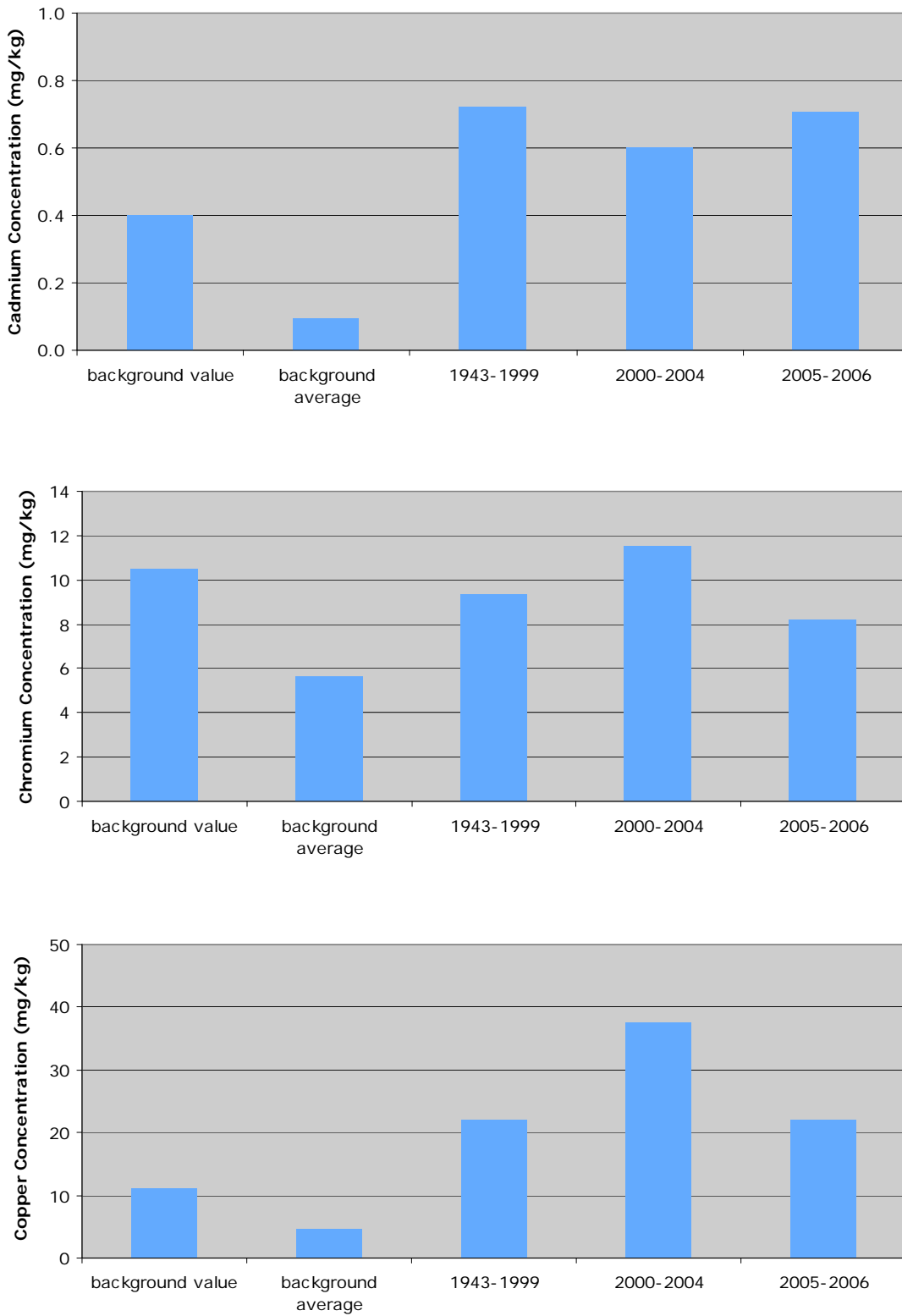

Figure 7.1-18 Temporal variations in the average concentrations of cadmium, chromium, and copper in fine facies sediment in reach PA-2W.

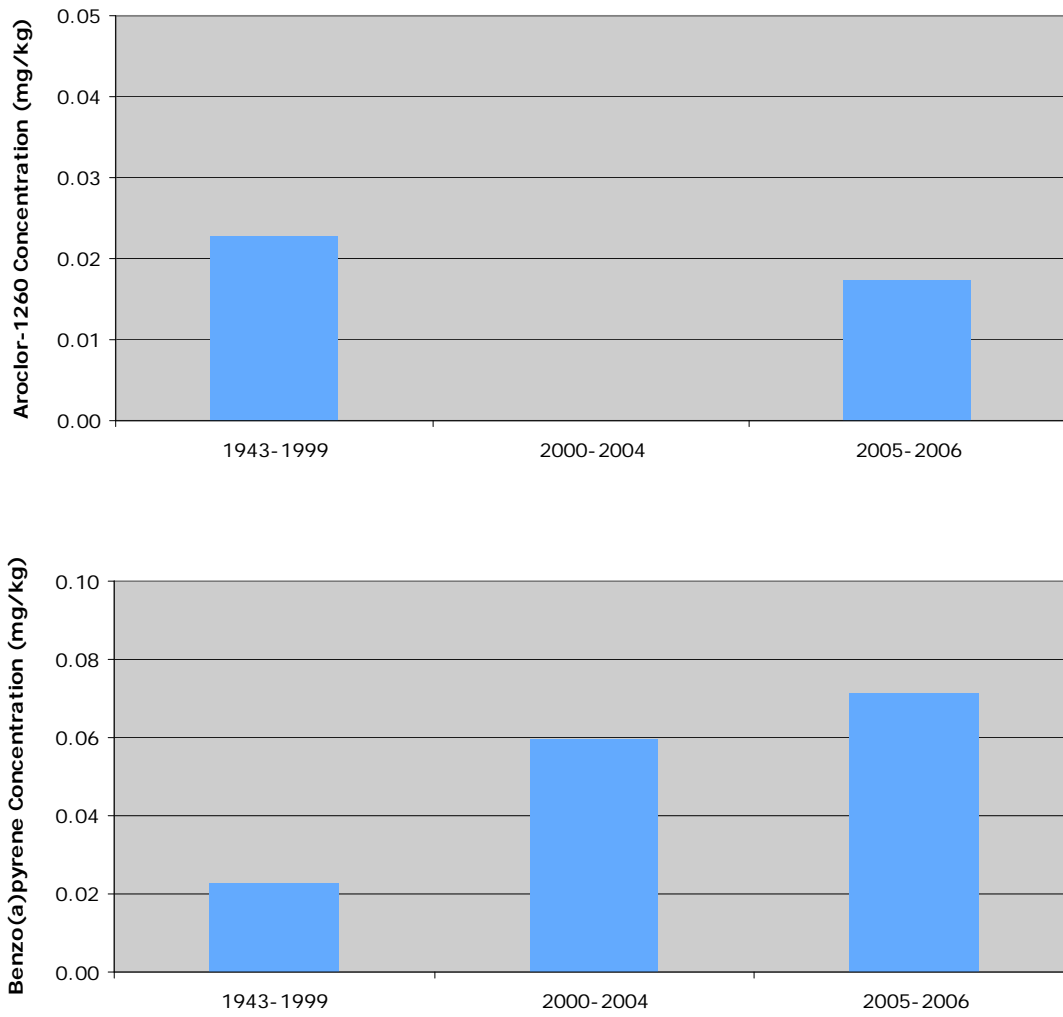

Figure 7.1-19 Temporal variations in the average concentrations of Aroclor-1260 and benzo(a)pyrene in fine facies sediment in reaches TW-4W and TW-4E.

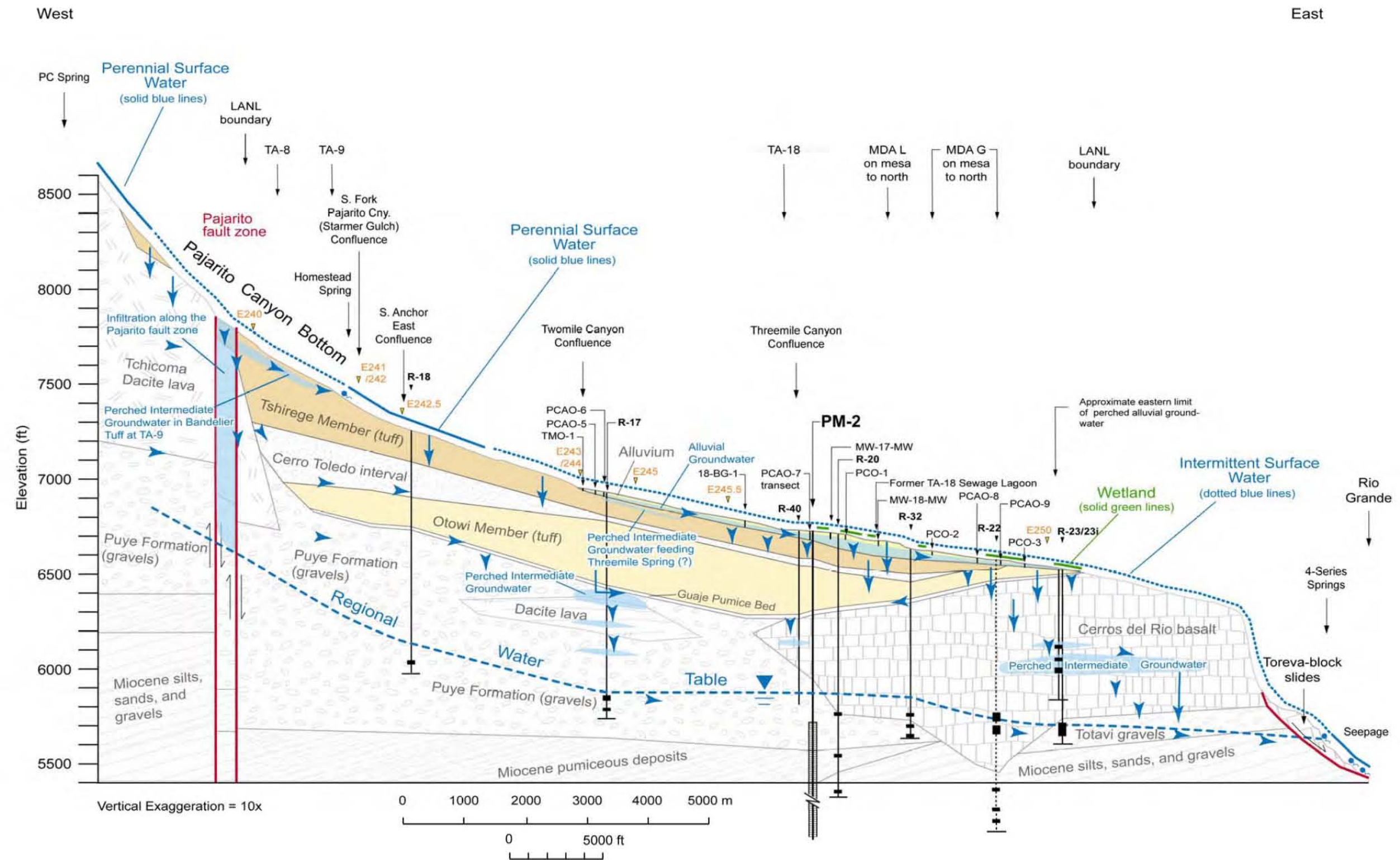

Figure 7.2-1 Conceptual hydrogeologic cross section for Pajarito Canyon. Line of section follows the canyon stream channel. Potential groundwater pathways are shown with blue arrows. Wells on the line of section are shown by solid lines; well R-22 is projected onto the line of section as a dashed line.

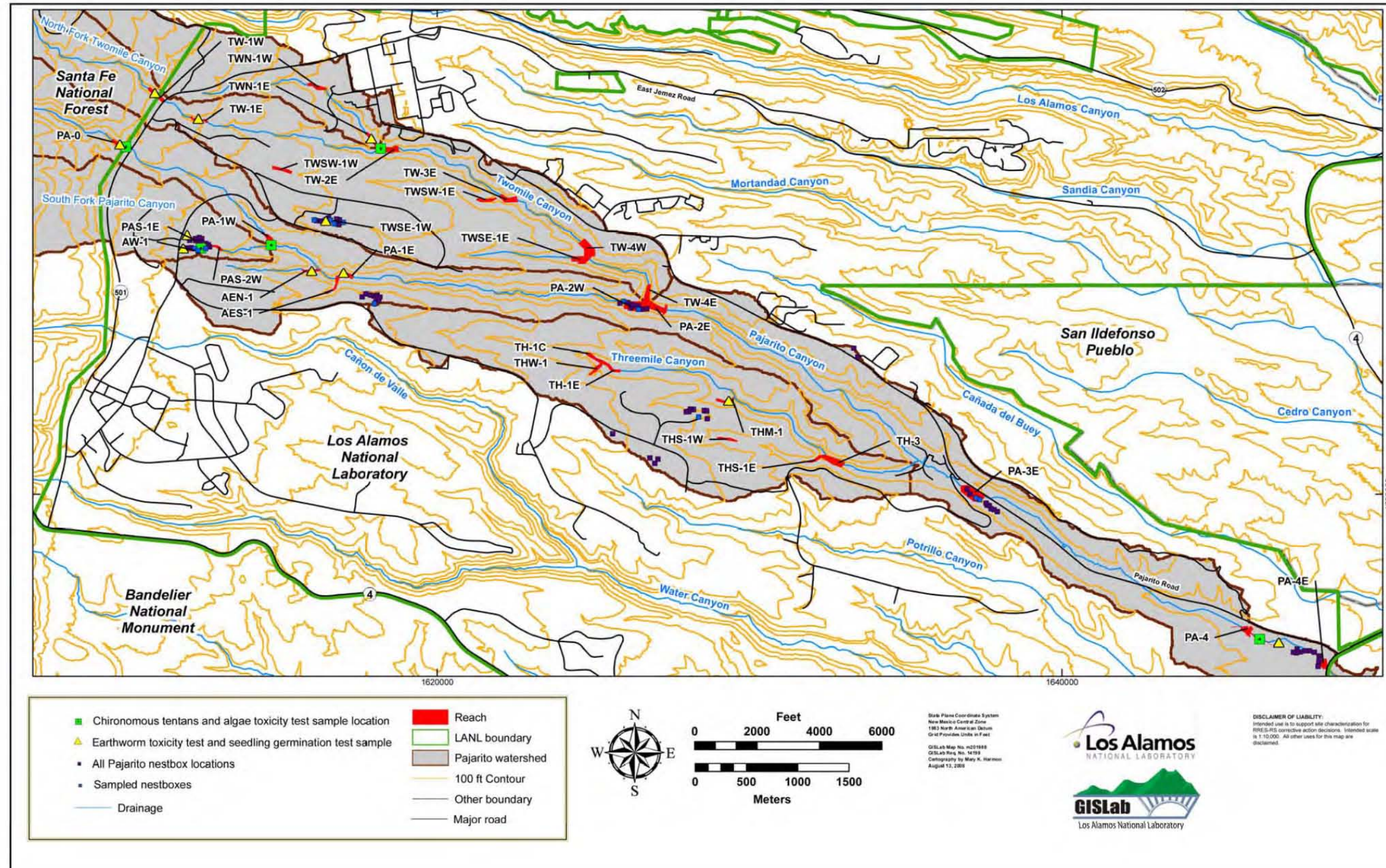

Figure 8.1-1 Biota investigation locations in the Pajarito watershed

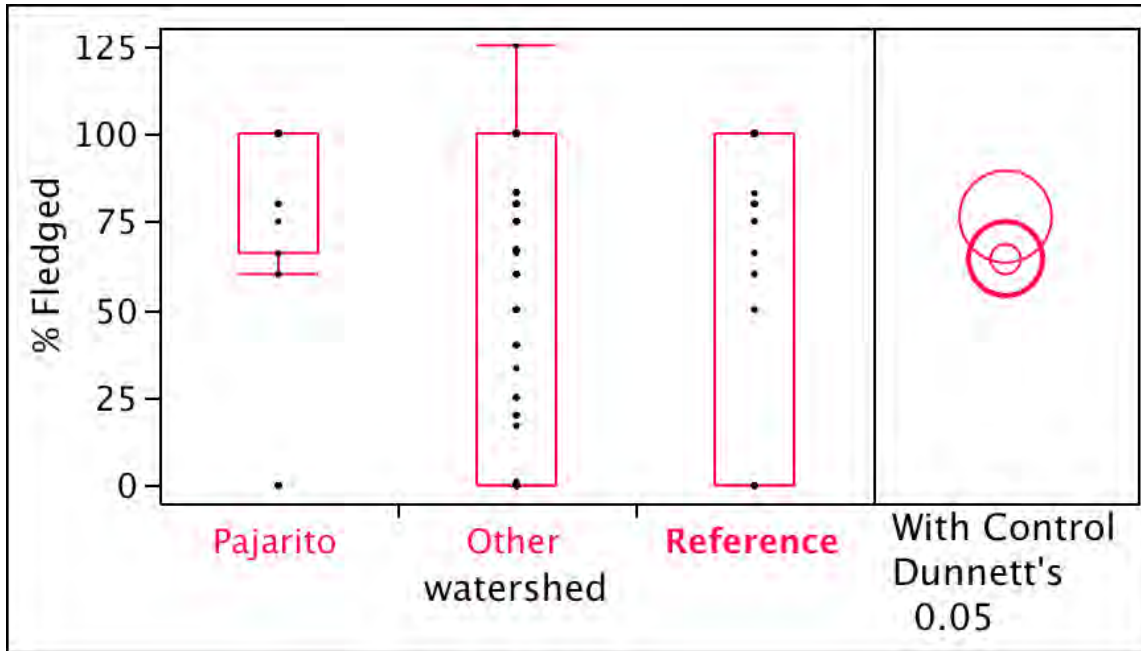

Figure 8.1-2 Box plots showing percent fledged in the Pajarito watershed compared with reference for western bluebirds

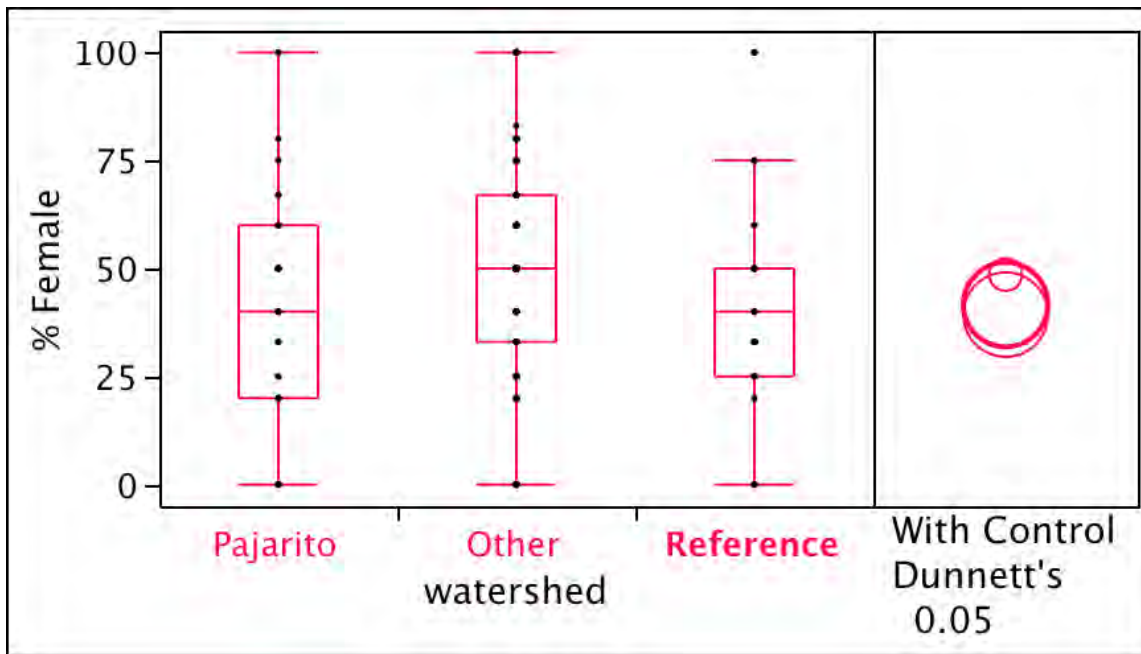

Figure 8.1-3 Box plots showing percent female in the Pajarito watershed compared with reference for western bluebirds

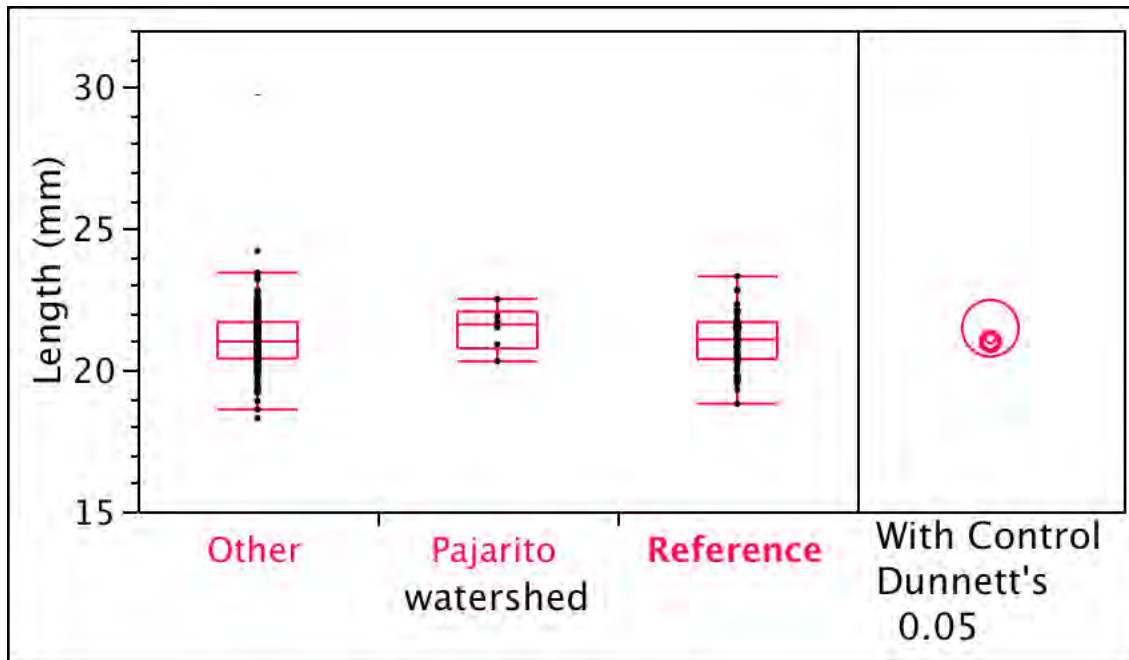

Figure 8.1-4 Box plots showing egg length for the Pajarito watershed compared with reference for western bluebirds

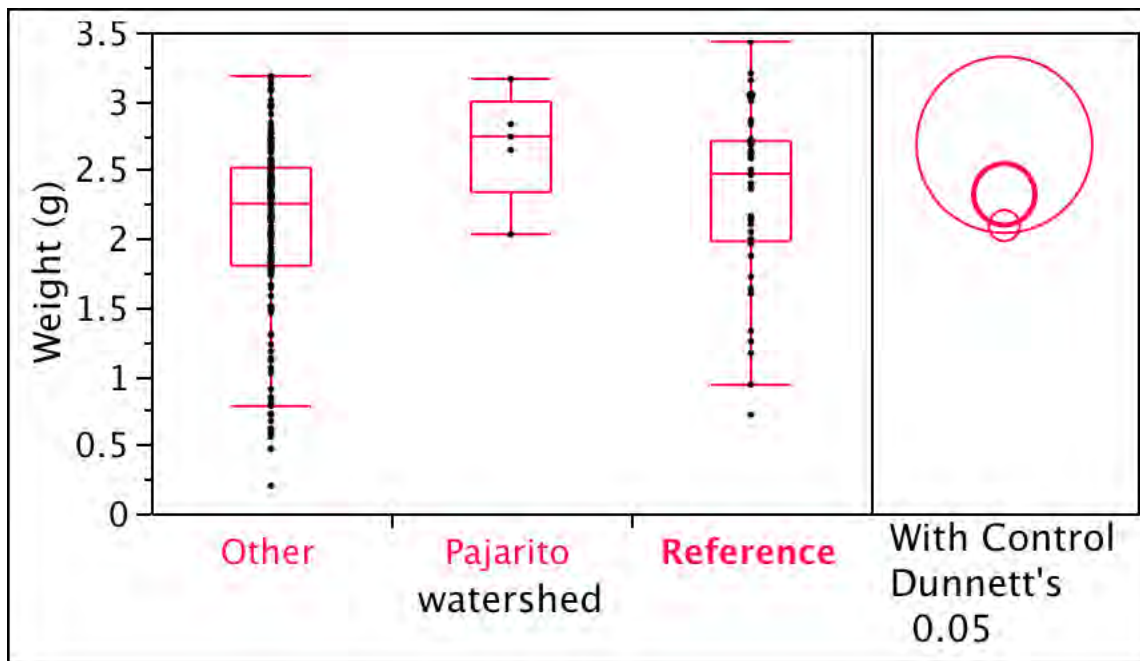

Figure 8.1-5 Box plots showing egg weight for the Pajarito watershed compared with reference for western bluebirds

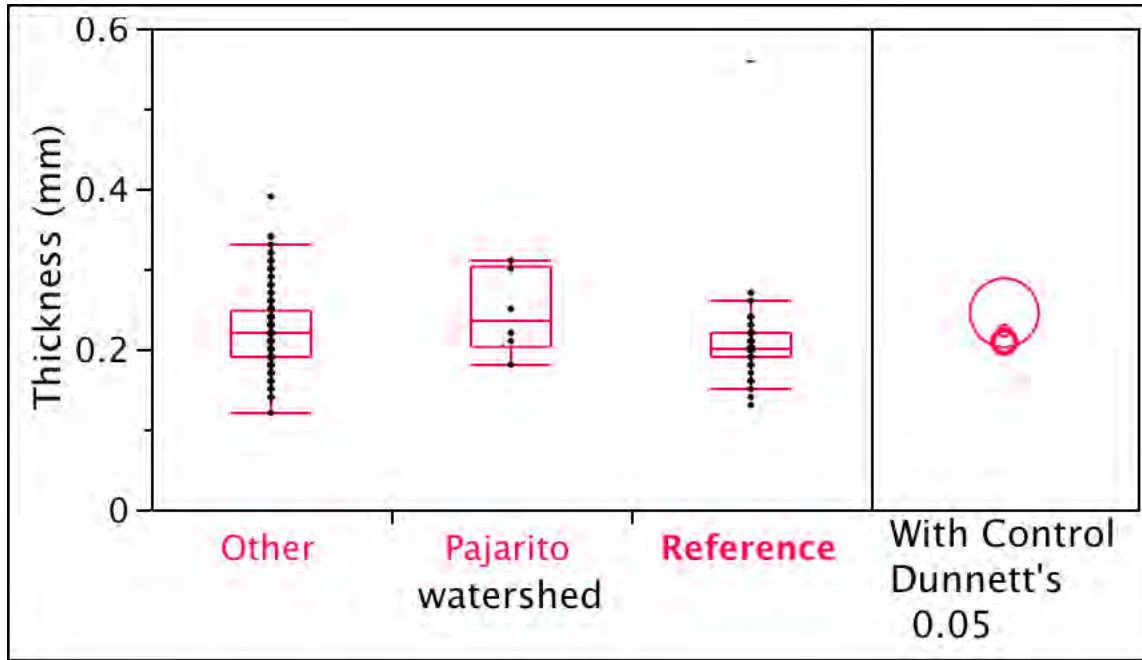

Figure 8.1-6 Box plots showing eggshell thickness for the Pajarito watershed compared with reference for western bluebirds

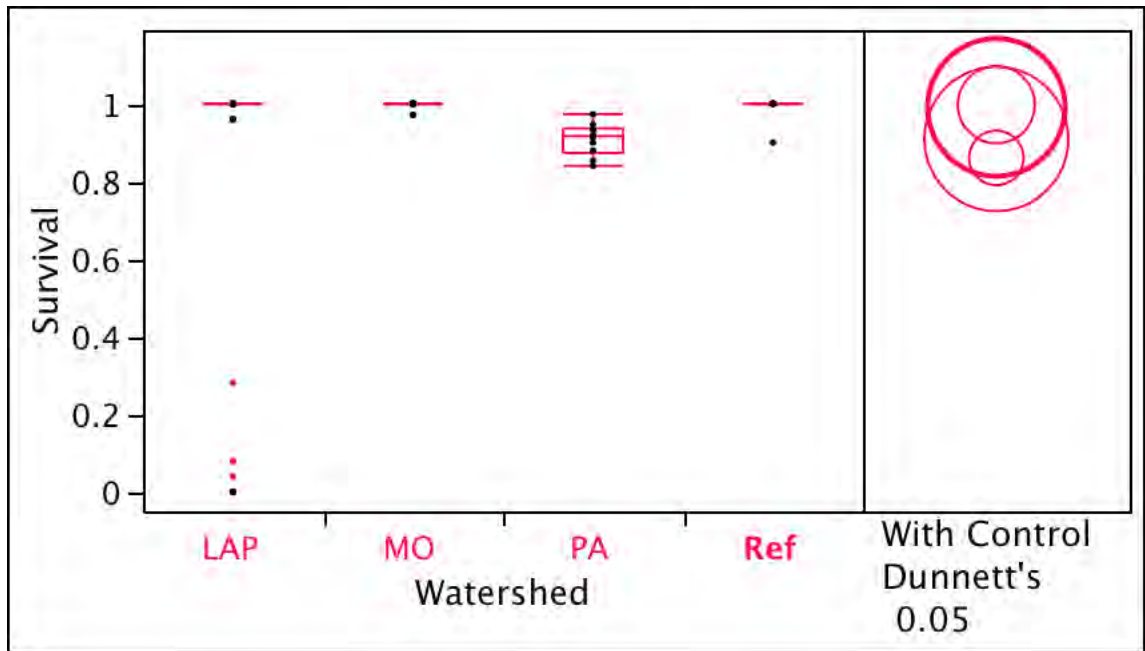

Figure 8.1-7 Survival of earthworms in toxicity test compared with reference

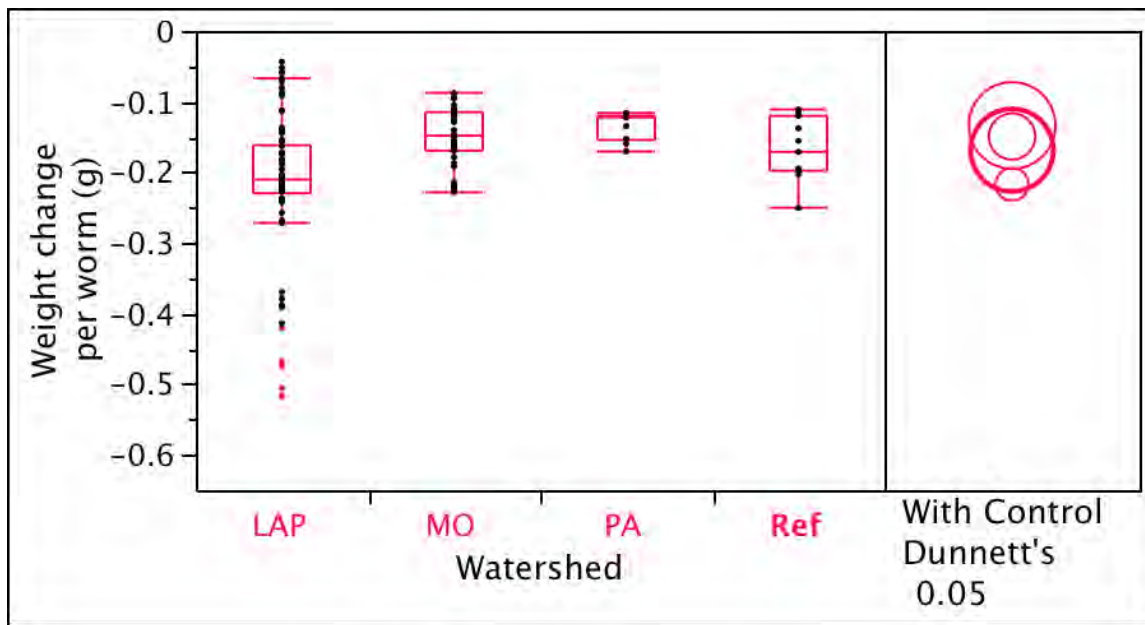

Figure 8.1-8 Weight change in earthworms during toxicity test compared with reference

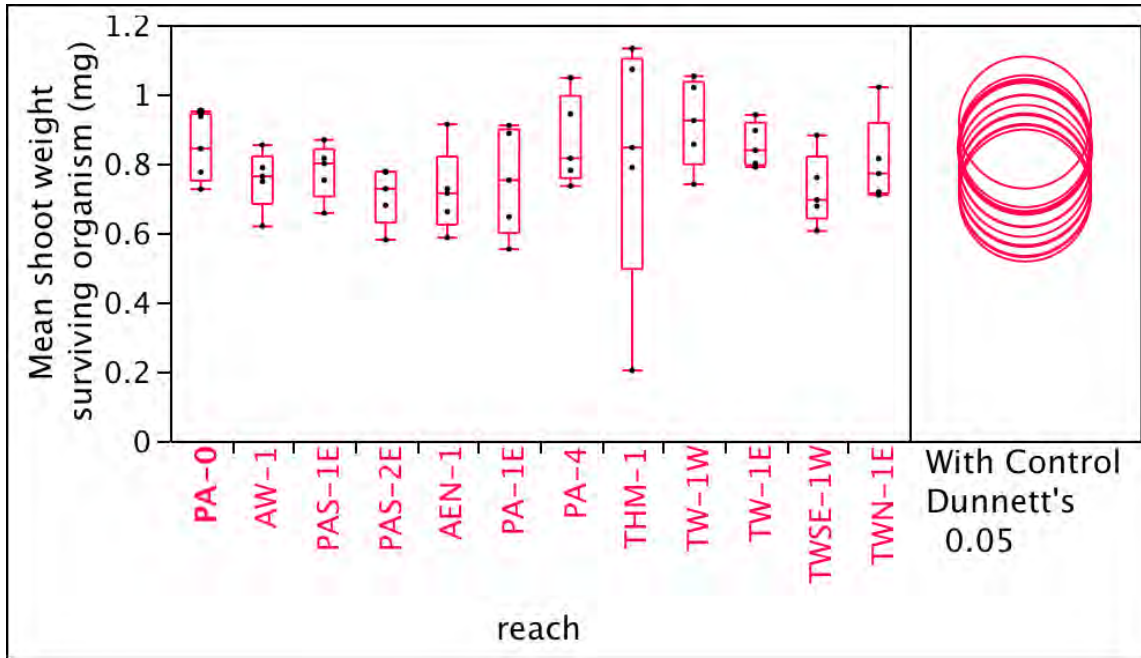

Figure 8.1-9 Shoot weight of surviving organisms in toxicity test by reach

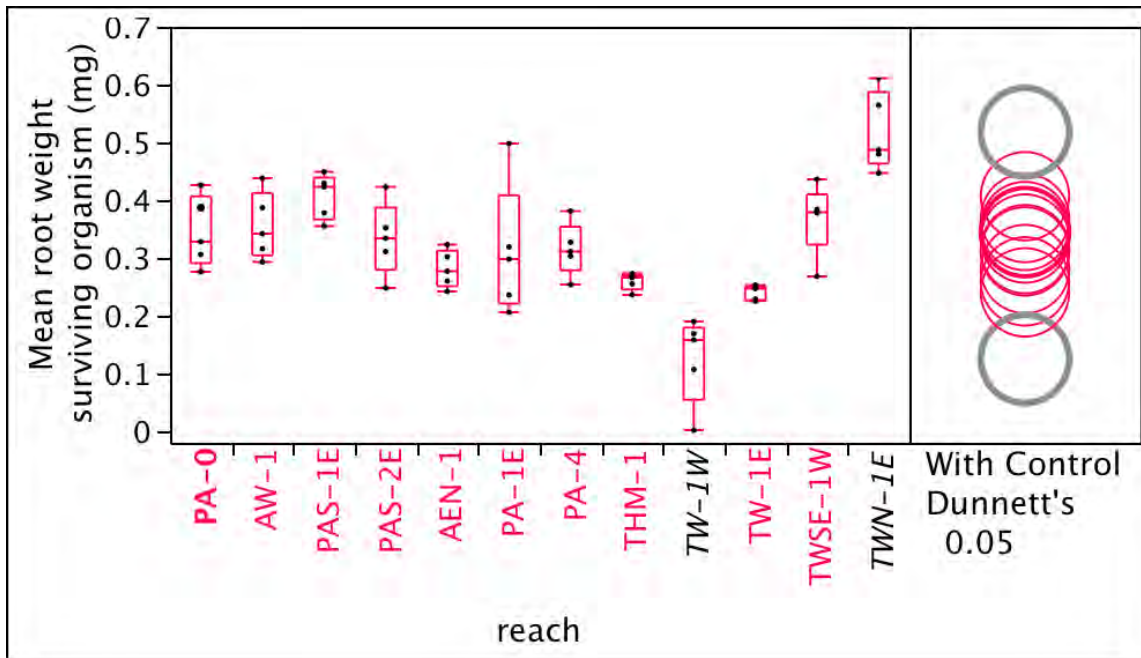

Figure 8.1-10 Root weight of surviving organisms in toxicity test by reach

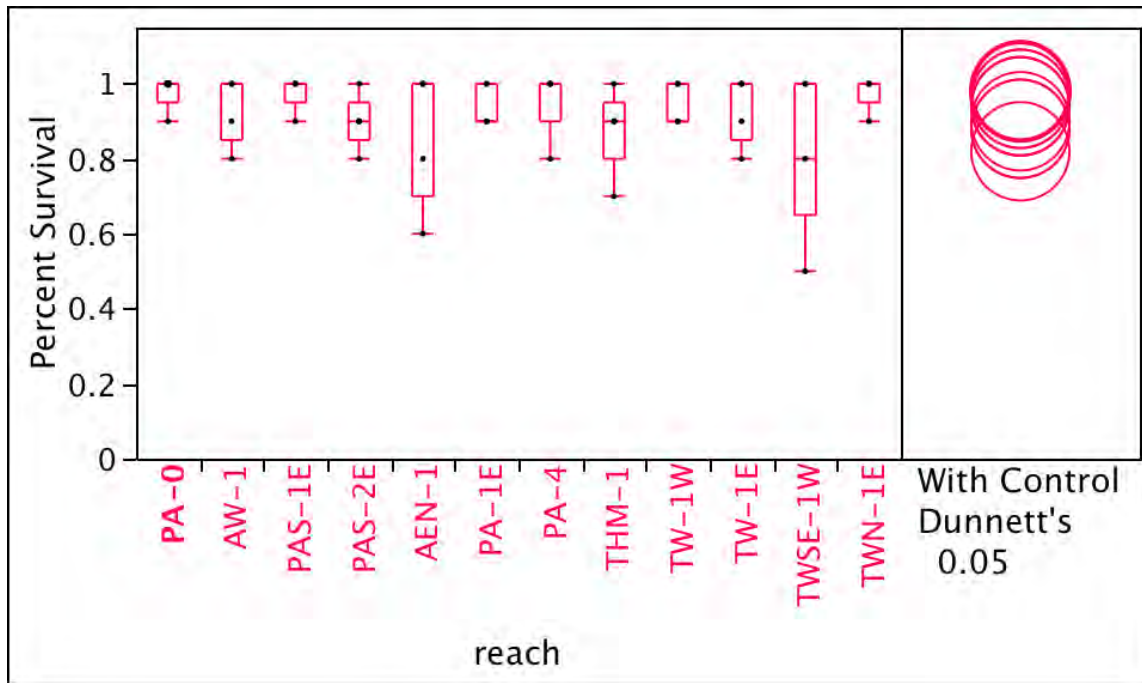

Figure 8.1-11 Fraction of plants surviving at end of toxicity test by reach

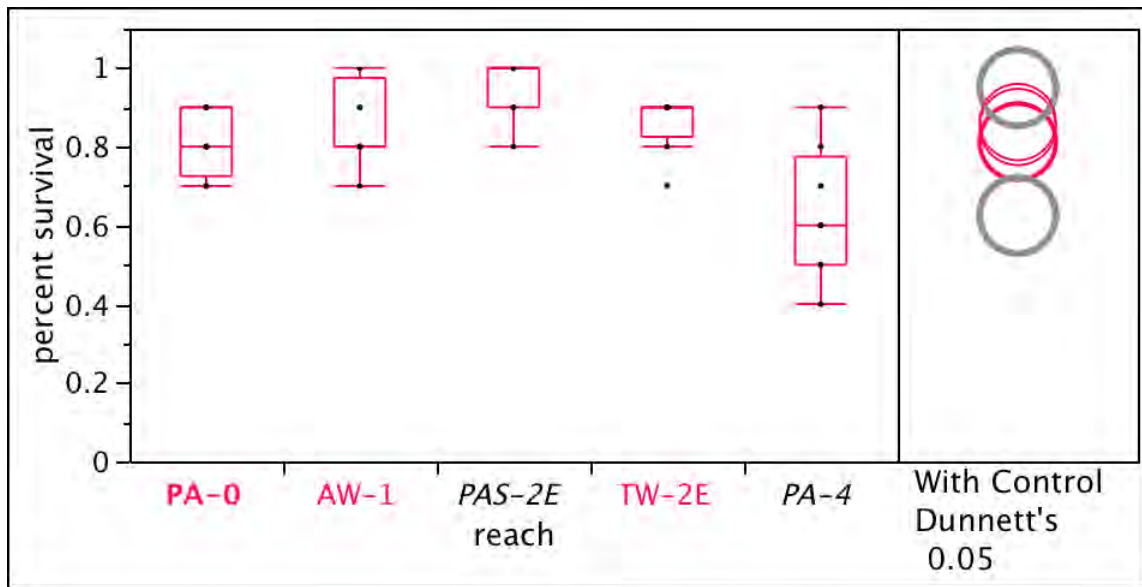

Figure 8.1-12 Percent survival at conclusion of chironomid toxicity test

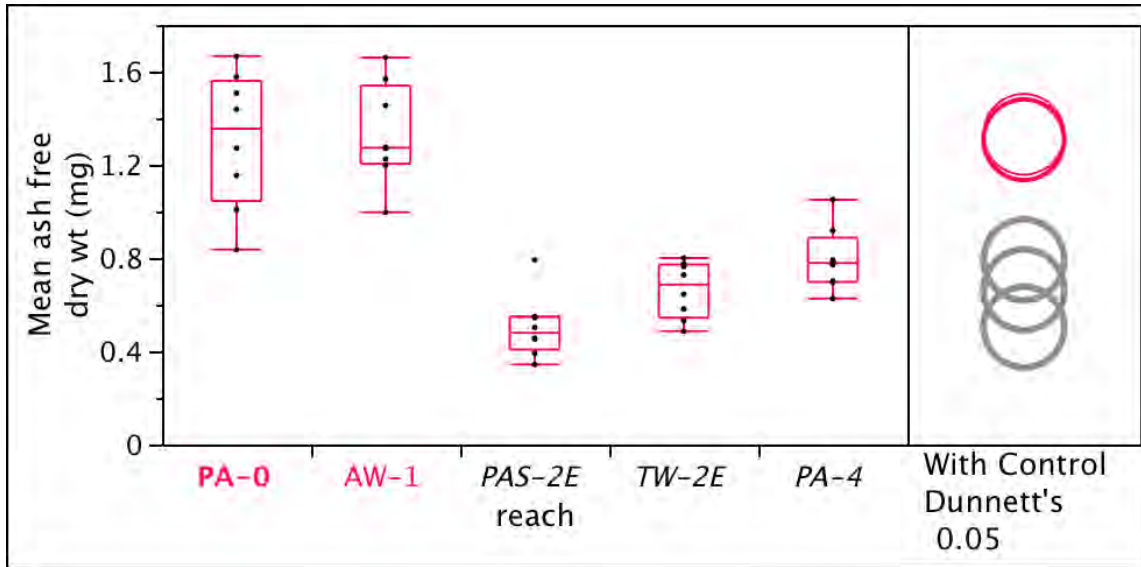

Figure 8.1-13 Box plot of mean dry larval weight (in mg) per replicate after chironomid toxicity test

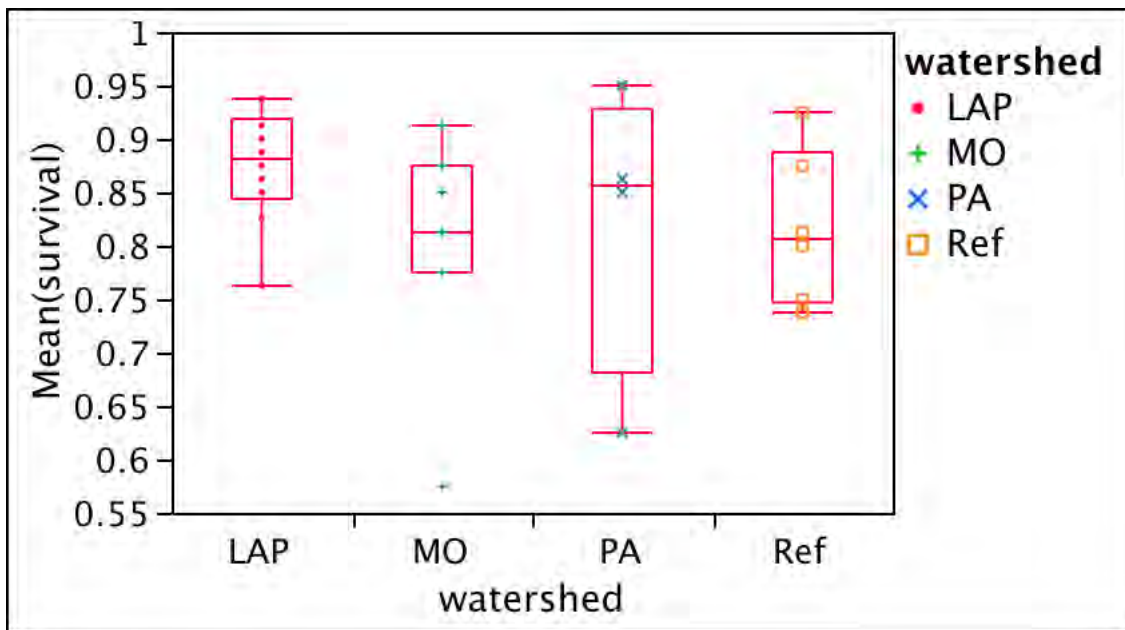

Figure 8.1-14 Box plot of mean chironomid survival compared with reference.

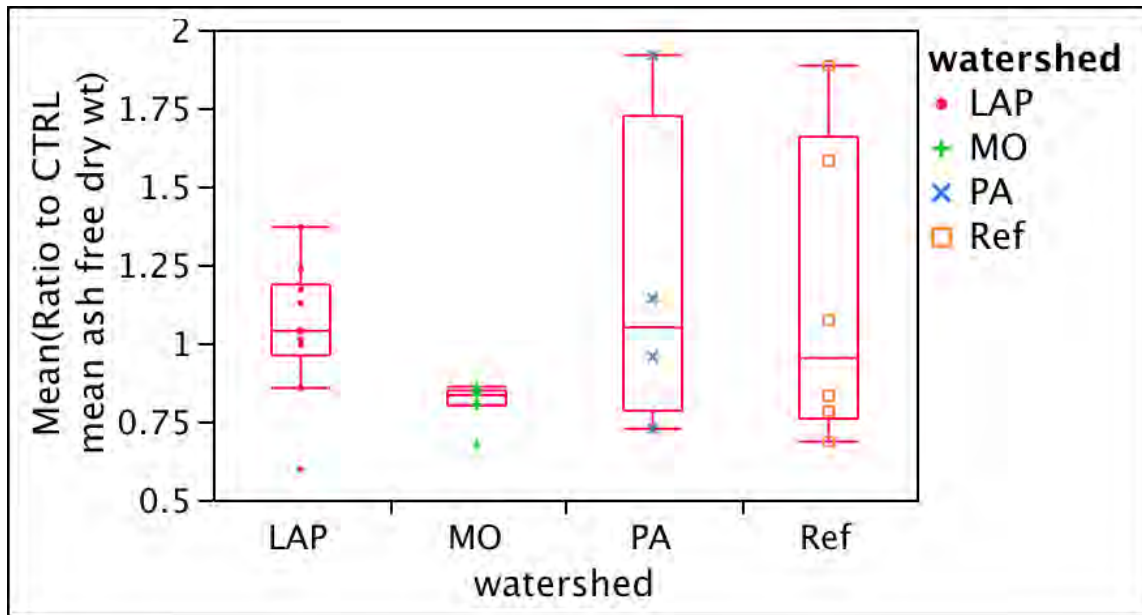

Figure 8.1-15 Box plot of mean chironomid growth relative to laboratory control compared with reference

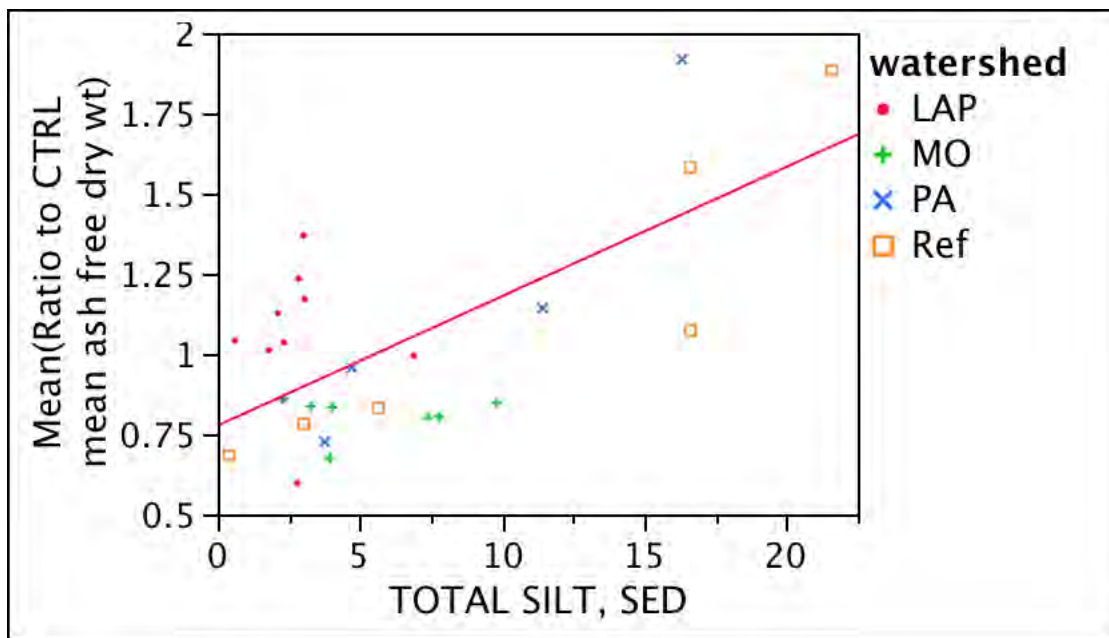

Figure 8.1-16 Scatter plot of mean chironomid growth relative to laboratory control versus total silt. Linear regression: $y = 0.78 + 0.040 \cdot X$; $r^2 = 0.46$; $n = 27$

**Table 3.1-1
Sediment Investigation Reaches in the Pajarito Watershed**

Sub-Watershed	Investigation Reach	Reach Abbreviation	Approximate Distance From Rio Grande to Midpoint of Reach (km)	Reach Length (km) ^a	Year(s) of Sample Collection (Canyons Investigations)	Notes
Pajarito	AEN-1	AEN-1	16.14	0.20	2005, 2007	Lower end of north Anchor East basin (aka "Arroyo de LaDelfe"); downcanyon of TA-09 SWMUs
	AES-1	AES-1	15.91	0.20	2005	Lower end of south Anchor East basin; downcanyon of TA-09 SWMUs
	AW-1	AW-1	17.40	0.26	2006, 2007	Lower end of Anchor West basin; south fork Pajarito Canyon basin downcanyon of TA-08 SWMUs
	PA-0	PA-0	18.49	0.20	2000, 2006, 2007	Up canyon of NM 501; background reach
	PA-1 West	PA-1W	16.66	0.20	2006	Up canyon of south fork Pajarito Canyon
	PA-1 East	PA-1E	15.71	0.20	2000, 2006, 2007	Downcanyon of south Anchor East basin
	PA-2 West	PA-2W	12.82	0.25	2000, 2005, 2006, 2007	Up canyon of Twomile Canyon
	PA-2 East	PA-2E	12.61	0.17	nc ^b	Downcanyon of Twomile Canyon; up canyon of Pajarito FRS
	PA-3 East	PA-3E	8.64	0.28	2005, 2007	Downcanyon of TA-18
	PA-4	PA-4	5.67	0.55	2000, 2004, 2005, 2007	Downcanyon of TA-54
	PA-4 East	PA-4E	4.88	0.10	2000	Up canyon of SR 4
	PA-5 West	PA-5W	1.47	0.20	2006	Downcanyon of White Rock
	PAS-1 East	PAS-1E	17.37	0.20	2006, 2007	South fork Pajarito Canyon up canyon of Anchor West Basin and downcanyon of TA-08 SWMUs
	PAS-2 West	PAS-2W	17.17	0.20	2005	South fork Pajarito Canyon downcanyon of Anchor West Basin
PAS-2 East	PAS-2E	15.64	nm ^c	2007	Lower end of south fork Pajarito Canyon (aka "Starmer Gulch")	

Table 3.1-1 (continued)

Threemile	TH-1 Central	TH-1C	13.08	0.20	2006	Upcanyon of west fork Threemile Canyon
	TH-1 East	TH-1E	12.88	0.20	2005	Downcanyon of west fork Threemile Canyon
	TH-3	TH-3	10.31	0.20	2000	Downcanyon of south fork Threemile Canyon
	THM-1	THM-1	11.61	0.20	2005, 2007	Lower end of middle fork Threemile Canyon
	THS-1 West	THS-1W	11.47	0.20	2006	South fork Threemile Canyon downcanyon of R-44 firing site
	THS-1 East	THS-1E	10.51	0.20	2005	Lower end of south fork Threemile Canyon
	THW-1	THW-1	13.08	0.20	2006	Lower end of west fork Threemile Canyon
Twomile	TW-1 West	TW-1W	18.58	0.20	2006, 2007	Upcanyon of NM 501; background reach
	TW-1 East	TW-1E	18.01	0.20	2005, 2006, 2007	Downcanyon of TA-69 SWMUs
	TW-2 East	TW-2E	16.10	0.20	2000, 2007	Downcanyon of north fork Twomile Canyon
	TW-3 East	TW-3E	14.66	0.20	2006	Downcanyon of southwest fork Twomile Canyon
	TW-4 West	TW-4W	13.71	0.20	2000, 2005	Upcanyon of southeast fork Twomile Canyon
	TW-4 East	TW-4E	12.79	0.20 ^d	2006, 2007	Upcanyon of Pajarito Canyon
	TWN-1 West	TWN-1W	17.09	0.20	2006	North fork Twomile Canyon downcanyon of NM 501; baseline reach
	TWN-1 East	TWN-1E	16.24	0.20	2005, 2006, 2007	Lower end of North Fork Twomile Canyon
	TWSE-1 West	TWSE-1W	16.30	0.20	2006, 2007	Southeast fork Twomile Canyon downcanyon of TA-22 SWMUs
	TWSE-1 East	TWSE-1E	13.71	0.20	2000, 2005	Lower end of southeast fork Twomile Canyon
	TWSW-1 West	TWSW-1W	17.04	0.20	2006	Southwest fork Twomile Canyon upcanyon of TA-06 SWMUs; baseline reach
	TWSW-1 East	TWSW-1E	14.91	0.20	2000, 2005	Lower end of southwest fork Twomile Canyon

^a Length refers to area mapped and characterized.

^b nc = Reach mapped but not characterized; no samples collected.

^c nm= Reach not mapped; one sediment sample collected from active stream channel for biota investigation.

^d Reach not fully characterized; four sediment samples collected in area of Pajarito FRS impoundment after August 24, 2005 and August 25, 2006 floods.

**Table 3.2-1
Pajarito Canyon Surface-Water and Groundwater-Sampling Locations and Rationale**

Location Name	Location and Rationale
Base Flow (west to east)	
Pajarito 0.5 mi above SR-501 (PBF-B)	Background location in Pajarito Canyon. Located approx. 0.5 mi above NM 501. Provides a basis for comparison to data from downstream locations.
Pajarito below confluence of South and North Anchor East Basin (PBF-1)	Surface water in Pajarito Canyon below the confluence of north Anchor East basin (below gaging station E242.5). Location selected to monitor potential cumulative impacts of SWMUs and AOCs in upcanyon parts of the Pajarito watershed.
Twomile Canyon below TA-59 (PBF-2)	Surface water in Twomile Canyon below TA-59. Location selected to monitor potential cumulative impacts of SWMUs and AOCs in upper Twomile watershed.
Twomile above Pajarito (E244) Formerly PBF-3	Surface-water base flow collected at gaging station E244. Location selected to monitor potential cumulative impacts in Twomile watershed.
Pajarito above Two Mile (E243) Formerly PBF-4	Surface-water base flow collected at gaging station E243. Location selected to monitor potential cumulative impacts in upper Pajarito watershed.
Pajarito below TA-18 (PBF-5)	Surface water in Pajarito Canyon below TA-18. Location selected to monitor below TA-18 at road crossing near R-20.
Springs (west to east)	
PC Spring	Pajarito Canyon west of West Jemez Road (NM 501), probably regional groundwater. Provides background water quality.
Homestead Spring	Likely spring with largest discharge, downgradient of TA-09 (MDA M)
Starmer Spring	Speculated to be intermediate water in Bandelier Tuff. Provides baseline water quality upgradient of HE facilities
Anderson Spring	Located in Twomile Canyon downgradient of TA-69 and above potential sources of contamination in TA-03
Kieling Spring	Spring with history of HE contamination, downgradient of TA-09
Charlie's Spring	Monitors potential contamination from TA-08 area
Bulldog Spring	Spring with history of HE contamination, downgradient of TA-09
TW-1.72 Spring	In Twomile Canyon, downgradient of TA-03 facilities
Threemile Spring	In Threemile Canyon, upgradient of TA-18 and downgradient of TA-15 firing site facilities
TA-18 Spring	In Threemile Canyon, upgradient of TA-18 and downgradient of TA-16 firing site facilities
Alluvial Groundwater Wells (west to east)	
PCAO-B	Pajarito Canyon west of West Jemez Road (NM 501). Provides samples of baseline alluvial water upstream of Laboratory release sites in the Pajarito watershed. Attempt to install well unsuccessful because of lack of water above shallow bedrock.
PCAO-2	TA-09 in upper Pajarito Canyon below the confluence with south Anchor East basin. Provides samples of alluvial groundwater from the upper part of the Pajarito watershed below the influence of the TA-09 facilities in south Anchor East basin. Attempt to install hand-augered well unsuccessful because of shallow refusal on alluvial boulders and cobbles. Core sample collected.

Table 3.2-1 (continued)

Location Name	Location and Rationale
Alluvial Groundwater Wells (west to east) (continued)	
PCAO-3	TA-14 in upper Pajarito Canyon below the confluence with south fork of Pajarito Canyon ("Starmer Gulch"). Provide samples of alluvial groundwater from the upper part of the Pajarito watershed below the influence of facilities in the south fork of Pajarito Canyon. Attempt to install hand-augered well unsuccessful because of shallow refusal on alluvial boulders and cobbles. Core sample collected.
PCAO-4	TA-67 in middle Pajarito Canyon above the confluence with Twomile Canyon. Provide samples of alluvial groundwater from the upper part of the Pajarito watershed. Provide baseline data for Pajarito Canyon above the Twomile Canyon confluence. Attempt to install hand-augered well unsuccessful because of shallow refusal on alluvial boulders and cobbles. Core sample collected.
TMO-1	TA-66 in lower Twomile Canyon above the confluence with Pajarito Canyon. Provides samples of alluvial groundwater from the Twomile watershed. Hand-augered well successfully installed. Core sample collected.
PCAO-5	TA-66 in middle Pajarito Canyon approximately 100 ft west of Pajarito Canyon FRS. Provides samples of alluvial groundwater from the upper part of the Pajarito watershed. Provides samples of alluvial groundwater upgradient of the FRS. Well successfully installed by hollow-stem auger (HSA). Core samples collected.
PCAO-6	TA-66 in middle Pajarito Canyon approximately 300 ft east of FRS. Provides samples of alluvial groundwater downgradient of the FRS. Well successfully installed by HSA. Core sample collected.
18-BG-1	West of TA-18 in middle Pajarito Canyon. Provides samples of alluvial groundwater upgradient of TA-18. Well installed before this investigation.
18-MW-9	TA-18 in middle Pajarito Canyon. Provides samples of alluvial groundwater within the TA-18 site. Well installed before this investigation.
18-MW-11	TA-18 in middle Pajarito Canyon. Provides samples of alluvial groundwater within the TA-18 site. Well installed before this investigation.
3MAO-1	TA-67 in middle Threemile Canyon. Provides samples of alluvial groundwater from the upper part of the Threemile watershed. Attempts to install hand-augered well at 2 locations 400 ft apart were unsuccessful because of shallow refusal in the alluvium. Core sample collected.
3MAO-2	TA-18 in lower Threemile Canyon above the confluence with Pajarito Canyon. Provides samples of alluvial groundwater from Threemile watershed. Well successfully installed by HSA. Core samples collected.
18-BG-4	TA-18 in lower Threemile Canyon above the confluence with Pajarito Canyon. Provide samples of alluvial groundwater from Threemile watershed upgradient of TA-18. Well installed before this investigation.
18-MW-8	TA-18 in lower Threemile Canyon above the confluence with Pajarito Canyon. Provide samples of alluvial groundwater from Threemile watershed. Well installed before this investigation.
PCAO-7(a)	Lower Pajarito Canyon just east of TA-18 complex, north of Pajarito Road. Part of a transect of wells across Pajarito Canyon to monitor water quality and water levels downgradient of TA-18. Well successfully installed by HSA. Core samples collected.
PCAO-7(b1)	Lower Pajarito Canyon just east of TA-18 complex, north of Pajarito Road. Part of a transect of wells across Pajarito Canyon to monitor water quality and water levels downgradient of TA-18. Well successfully installed by HSA in deep part of the alluvium.
PCAO-7(b2)	Lower Pajarito Canyon just east of TA-18 complex, north of Pajarito Road. Part of a transect of wells across Pajarito Canyon to monitor water quality and water levels downgradient of TA-18. Well successfully installed by HSA in shallow part of the alluvium. Core samples collected.

Table 3.2-1 (continued)

Location Name	Location and Rationale
PCOA-7(c)	Lower Pajarito Canyon just east of TA-18 complex, south of Pajarito Road. Part of a transect of wells across Pajarito Canyon to monitor water quality and water levels downgradient of TA-18. Well successfully installed by HSA. Core samples collected.
18-MW-18	TA-36 on the south side of Pajarito Road in lower Pajarito Canyon, near former sewage lagoons. Provides samples of alluvial groundwater from Pajarito watershed between MDA L and MDA G. Well installed before this investigation.
PCO-2	TA-36 on the north side of Pajarito Road in lower Pajarito Canyon, at west end of MDA G. Provides samples of alluvial groundwater from Pajarito watershed downgradient of MDA L and upgradient of MDA G. Well installed before this investigation.
PCOA-8	TA-36 on the south side of Pajarito Road in lower Pajarito Canyon, south of MDA G. Provides samples of alluvial groundwater from Pajarito watershed between TA-18 and MDA G. Well successfully installed by HSA. Core samples collected.
PCAO-9	TA-36 on the south side of Pajarito Road in lower Pajarito Canyon, east of MDA G. Provides samples of alluvial groundwater downgradient of MDA G. Well successfully installed by HSA. Core samples collected.
PCO-3	TA-36 on the south side of Pajarito Road in lower Pajarito Canyon, east of MDA G. Provides samples of alluvial groundwater downgradient of MDA G. Well installed before this investigation.
Perched Intermediate Groundwater (west to east)	
03-B-9	TA-03 on west side of warehouse 03-0030, mesa-top site. Well installed as part of investigation of contamination of shallow perched groundwater. Well installed before this investigation.
03-B-10	TA-03 near southwest corner of warehouse 03-0030, mesa-top site. Well installed as part of investigation of contamination of shallow perched groundwater. Well installed before this investigation.
03-B-11	TA-03 near northwest corner of warehouse 03-0030, mesa-top site. Well installed as part of investigation of contamination of shallow perched groundwater. Well installed before this investigation.
R-19, screen 2	TA-36 on mesa south of south fork of Threemile Canyon. Provides water-quality and water-level data for intermediate depth perched groundwater in the vicinity of HE firing sites. Well screens 1 and 2 target perched intermediate groundwater. Screen 1 is dry, and screen 2 is monitored for water quality and water levels.
R-23i	Pajarito Canyon east of MDA G and west of White Rock. Provides water-quality and water-level data for intermediate depth perched groundwater encountered during the drilling of R-23. Completed as a 4.5-in. diameter well with two screened intervals: one between 470.2 and 480.1 ft bgs and the other between 524 and 547 ft bgs. Additionally, a 2-in. diameter well was installed in the R-23i annular space with a screened interval between 400.3 and 420 ft bgs.
Regional Groundwater (west to east)	
R-18	TA-14 on the south rim of Pajarito Canyon. Provides water-quality and water-level data for regional groundwater downgradient of inactive HE liquid waste outfalls at TA-09 and other potential upgradient release sites to the west. Also determines the lateral extent of HE contamination from Cañon de Valle release sites. Well installed with one screen from 1358 to 1381 ft bgs.

Table 3.2-1 (continued)

Location Name	Location and Rationale
R-17	TA-66 in middle Pajarito Canyon east of FRS. Provide samples of regional groundwater downgradient of potential release sites in the upper Pajarito watershed. Well installed with two screens: one from 1124 to 1134 ft bgs and one from 1057 to 1080 ft bgs in the regional aquifer. Core collected for contaminant characterization in adjacent borehole to a TD of 300.9 ft.
R-19, screens 3, 4, 5, 6, and 7	TA-36 on mesa south of south fork of Threemile Canyon. Provides water-quality and water-level data for regional groundwater in the vicinity of HE firing sites. Well screens 3 through 7 target regional groundwater at the intervals 1171.4–1215.4 ft, 1410.2–1417.4 ft, 1582.6–1589.8 ft, 1726.8–1733.9 ft, and 1832.4–1839.5 ft bgs.
R-20	TA-36 on the south side of Pajarito Road in lower Pajarito Canyon, east of TA-18 complex. Provides samples of regional groundwater from Pajarito watershed in the vicinity of TA-18 and MDA L. Originally installed with three well screens at intervals of 904.6–912.2 ft, 1147.1–1154.7 ft, and 1328.8–1336.5 ft bgs, each sampled separately using a Westbay sampling system. Recently modified to sample top two screens using a Baski sampling system. Core collected for contaminant characterization in adjacent borehole to a TD of 436 ft.
R-32	TA-36 on the north side of Pajarito Road in lower Pajarito Canyon between MDA L and MDA G. Provides samples of regional groundwater downgradient of MDA L and upgradient of MDA G. Installed with three well screens at the intervals 876.5–875.3 ft, 931.8–934.9 ft, and 972.9–980.6 ft bgs, each sampled separately using a Westbay sampling system. Recently converted to a single-screen well using the uppermost well screen. Core collected for contaminant characterization in adjacent borehole to a TD of 318 ft.
R-22	TA-54 mesa top east of MDA G. Provides samples of regional groundwater downgradient of MDA G. Installed with five well screens at the intervals of 872.3–914.2 ft, 947.0–988.9 ft, 1272.2–1278.9 ft, 1378.2–1384.9 ft, and 1447.3–1452.3 ft, each sampled separately using a Westbay sampling system.
R-23	Pajarito Canyon east of MDA G and west of White Rock. Provides water-quality and water-level data for regional groundwater downgradient of MDA G. Well installed with one screened interval from 816 to 873.2 ft bgs.

Note: Grey shading indicates new wells required by the "Work Plan for Pajarito Canyon" (LANL 1998, 059577) and the "Approval with Modifications, Pajarito Canyon Work Plan" (NMED 2005, 091288).

**Table 6.1-1
Surface Water and Groundwater Location Synonyms**

Location Name	Location Synonym
03-B-10	G3B10
03-B-13	G3B13
03-B-9	G3B9
18-BG-1	G18B1
18-MW-11	242772
18-MW-18	G1818
18-MW-8	G18M8
18-MW-9	G18M9
Anderson Spring	GANDS
Bulldog Spring	GSLB

Table 6.1-1 (continued)

Location Name	Location Synonym
Charlie's Spring	GCHRS
Flood Water Over Bank Pajarito at G-1	M246.6
Homestead Spring	GSMH
Kieling Spring	GSLK
La Delfe above Pajarito	E242.5
Pajarito 0.5 mi above SR-501	PBFB
Pajarito above SR-4	E250
Pajarito above Starmers	E241
Pajarito above TA-18	E245
Pajarito above Threemile	E245.5
Pajarito above Twomile	E243
Pajarito at Rio Grande	WGRP
Pajarito at SR-4	S4RSP
Pajarito at SR-501	SRSP
Pajarito below confluences of South and North Anchor East Basin	PBF1
Pajarito below SR-501	E240
Pajarito below TA-18	PBF5
Pajarito Canyon	WCJP
Pajarito Retention Pond	EPRP
Pajarito SR-4 Culvert	M250.1
PC Spring	GSCP
PCO-1	G1CP
PCO-2	G2CP
PCO-3	G3CP
R-17	GR17
R-18	G18R
R-19	TH-10000
R-20	G20R
R-22	54-15421
R-23	GR23
R-23i	GR23I
R-32	G32R
Spring 4	G4SW
Spring 4A	GA4S
Spring 4AA	GAA4
Spring 4B	GB4S
Spring 4C	GC4S
Starmer Spring	GSTS
Starmers above Pajarito	E242
Starmer's Gulch above SR-501	M241.7
TA-18 Culvert	M246.5

Table 6.1-1 (continued)

Location Name	Location Synonym
TA-18 Spring	GS18
Threemile above Pajarito	E246
Threemile Spring	GSM3
TW-1.72 Spring	G172
Twomile above Pajarito	E244
Twomile above SR-501	SSMT

**Table 6.1-2
Crosswalk of Resamples and Original Samples for Sediment**

Newer Sample ID (Resample)	Original Sample ID
CAPA-05-62725	CA18-00-0030
CAPA-05-62726	CA18-00-0031
CAPA-05-63152	CAPA-04-53801
CAPA-05-63153	CAPA-04-53802
CAPA-05-63154	CAPA-04-53803
CAPA-05-63155	CAPA-04-53804
CAPA-05-63156	CAPA-04-53805
CAPA-05-63157	CAPA-04-53806
CAPA-05-63158	CAPA-04-53807
CAPA-05-63159	CAPA-04-53808
CAPA-05-63160	CA18-00-0033
CAPA-05-63161	CA18-00-0035
CATW-05-62396	CATW-00-0003
CATW-05-62397	CATW-00-0004
CATW-05-62398	CATW-00-0002
CATW-05-62399	CATW-00-0001
CATW-05-62400	CATW-00-0020
CATW-05-62401	CATW-00-0019
CATW-05-62402	CATW-00-0018
CATW-05-62403	CATW-00-0016
CATW-05-62404	CATW-00-0014
CATW-05-62405	CATW-00-0015
CATW-05-62406	CATW-00-0012
CAPA-06-71135	CA18-00-0022
CAPA-06-71136	CA18-00-0024

Table 6.2-1
Pajarito Sediment Inorganic COPCs

Reach	Aluminum	Antimony	Arsenic	Barium	Beryllium	Cadmium	Calcium	Chromium (I)	Cobalt	Copper	Cyanide [Total]	Iron	Lead	Magnesium	Manganese	Mercury (I)	Nickel	Nitrate	Perchlorate (I)	Potassium	Selenium	Silver	Thallium	Uranium (Calculated Total) (I)	Vanadium	Zinc
LANL sediment BV ^a	15400	0.83	3.98	127	1.31	0.4	4420	10.5	4.73	11.2	0.82	13800	19.7	2370	543	0.1	9.38	n/a ^b	n/a	2690	0.3	1	0.73	6.99	19.7	60.2
Residential SSL ^c	77800	31.3	3.9	15600	156	39	n/a	2100	1520	3130	1220	23500	400	n/a	3590	23	1560	100000	55	n/a	391	391	5.16	16	78.2	23500
AEN-1	21000	— ^d	6.56	220	—	4.74	6150	23.6	6.73 (J)	24.7	—	16000	22.2	2910	779 (J)	0.717	9.45	—	0.000726 (J)	2920 (J+)	0.842 (J)	6.59	1.71	8.74	43.4	71.8
AES-1	20100	—	5.75	173	—	—	—	12.9	11.7 (J)	—	—	15300	26.3	2650	791 (J)	—	—	—	—	—	1.56 (U)	—	—	—	31.1	—
AW-1	34600 (J+)	—	20	874	1.41	3.63	5170	71.6	10.4	41.4	—	24700 (J+)	77.2	4730	691	1.58	12.5 (J)	—	—	4540	2.84	55.1	—	10.41	86.1	154
PA-0	—	—	--	230 (J-)	—	0.534 (U)	8800 (J-)	—	5.32	—	2.5	—	—	—	668	—	—	—	0.000927 (J)	—	4.39	—	—	—	32.2	—
PA-1E	—	—	4.3	--	—	3.9	—	24	7.67	49	—	—	21.7	—	685	—	48	—	0.000574 (J)	—	0.9 (J-)	17	—	—	22	—
PA-1W	15800 (J+)	—	—	154 (J)	—	—	—	11.7	5.45 (J)	—	—	—	--	—	—	—	—	—	0.00104 (J)	—	1.92 (U)	—	—	—	25.6 (J)	—
PA-2W	20700	—	—	199	—	1.5	5790	16.4	8.74	90	0.835 (J-)	16000	--	2660 (J+)	653	—	41	—	0.00276 (J)	—	0.992 (J)	7.3	—	9.31	26	—
PA-3E	16700	—	—	430 (J+)	—	0.51 (J)	13800 (J+)	12.5	5.94	20.1	1.69	—	72.8	2890 (J+)	1460	—	12.8	—	0.00147 (J-)	—	0.85 (J)	—	—	—	20.8	83.2
PA-4	32300	0.95 (J-)	7.5 (J)	738	1.51 (J)	1.02 (J)	23400	19.8 (J)	10.8 (J)	37.7	2.3	23600	48.3	4650	2310	—	16.4 (J)	51.2 (J-)	—	4590	3.96	1.7 (J)	0.97 (U)	—	36.1	126 (J)
PA-4E	—	—	—	180 (J-)	—	—	6700 (J-)	—	—	—	0.99	—	—	—	—	—	—	—	—	—	0.77 (J-)	—	—	—	—	—
PA-5W	34700 (J+)	—	5.79	514 (J+)	1.7	1.02 (J)	15200	21.9	9.36	28.2	1.02 (J+)	23900	35.1	5830 (J+)	1260	—	18.9	—	—	4840 (J+)	0.749 (J)	—	—	—	39.8	113
PAS-1E	17900 (J+)	—	7.68	197	—	0.796	—	13.8	12.6	—	0.956	23000 (J+)	21.3	2410	829	—	—	—	—	—	1.28 (J)	44.9	—	—	41.3	65.7
PAS-2W	—	—	4.16	392	—	0.47 (J)	—	—	7.27	—	—	—	—	—	—	—	—	—	—	—	1.54 (U)	30	—	—	24	—
TH-1C	—	—	4.28	176 (J-)	—	2.53 (U)	—	—	5.36	—	—	19300	—	—	1860	—	—	—	—	—	1.38 (J)	—	—	14.52	—	91.3
TH-1E	28600	—	7.44	266	—	0.623 (U)	—	17.5	15.3	14.9	14.7 (UJ)	23000	—	3910 (J+)	1500	—	11.4	—	—	3360 (J+)	8.49 (U)	—	—	19.90	35.2	—
TH-3	—	—	—	—	—	—	—	—	—	—	—	—	—	—	—	—	—	—	—	—	0.84 (J-)	—	—	27.54	—	—
THM-1	—	—	—	131	6.41	0.424 (J)	4560	—	—	83.6	—	14100	84.6	—	—	—	—	—	—	—	1.75 (U)	—	—	153.89	—	—
THS-1E	—	—	—	132	—	0.639 (U)	—	—	—	19.6	—	15900	—	—	—	—	—	—	0.00153 (J-)	—	1.92 (U)	—	—	60.80	—	—
THS-1W	—	—	—	—	—	—	—	—	—	19.9	—	—	—	—	—	—	—	—	—	—	1.55 (U)	—	—	138.38	—	—
THW-1	18700	—	4.31	205	—	0.493 (J)	4750 (J-)	11.6	5.47	13.4	—	—	—	2820 (J+)	546	—	—	—	—	—	1.63 (U)	—	—	23.98	26.9	—
TW-1E	—	—	—	609	—	0.521 (U)	—	—	—	—	—	—	65.5	—	—	—	—	—	0.000717 (J)	—	1.56 (U)	31.4	—	—	—	131
TW-1W	—	—	—	234	—	0.43 (J)	7490	—	—	—	—	14600	24.8	—	924	—	—	—	0.00138 (J)	—	0.623 (J)	—	—	—	—	—
TW-2E	—	—	—	148	—	2	—	—	—	—	—	24600	23	—	606	—	—	—	—	—	2.78	1.42 (U)	—	—	23.3	107
TW-3E	—	—	6.15	—	—	0.411 (J)	13500	—	—	—	2.22 (J+)	—	--	—	—	—	—	—	0.000853 (J)	—	0.918 (J)	—	—	—	—	—
TW-4E	—	—	—	—	—	0.714(U)	—	—	—	—	—	—	--	—	—	—	—	—	0.00183 (J)	—	0.825 (J)	—	—	8.33	—	—
TW-4W	—	—	—	—	—	0.697 (U)	—	—	—	—	—	—	23	—	573	—	—	—	—	—	0.69 (J-)	—	—	—	—	64.9
TWN-1E	—	—	—	285	—	0.417 (J)	9800	—	7.5	13.4	0.846 (J+)	—	26.4	—	1020	—	—	—	0.000852 (J)	—	2.19 (U)	—	—	—	—	102

Table 6.2-1 (continued)

Reach	Aluminum	Antimony	Arsenic	Barium	Beryllium	Cadmium	Calcium	Chromium (1)	Cobalt	Copper	Cyanide [Total]	Iron	Lead	Magnesium	Manganese	Mercury (1)	Nickel	Nitrate	Perchlorate (1)	Potassium	Selenium	Silver	Thallium	Uranium (Calculated Total) (1)	Vanadium	Zinc
TWN-1W	—	—	4.39	136	—	0.497 (U)	—	10.6	—	11.4	—	—	42.1	—	595	—	—	—	0.000861 (J)	—	0.99 (J)	—	—	—	19.9	72.7
TWSE-1E	17800	—	4.18	151 (J+)	—	0.649 (U)	—	12.6	10	14	—	17600	—	2740	1200	—	—	—	0.000693 (J)	—	0.92 (J-)	—	0.77 (U)	—	25.4	—
TWSE-1W	20400	—	6	163	1.36 (J+)	0.528 (U)	—	14.5	7.71	98.1	6.52 (J-)	17100	—	2840	—	—	11.6	—	—	—	0.896 (J)	—	—	—	36.6	—
TWSW-1E	16300	—	4.75	262	—	0.44 (J)	10300	11.3	5.54	17.2	0.862	—	35.6	2430	1460	—	—	—	—	—	0.74 (J-)	—	—	11.22	22.3	79.1
TWSW-1W	20800 (J)	—	5.36	149 (J+)	—	0.488 (U)	—	13 (J)	6.23	—	0.858	17200 (J)	—	3080 (J+)	—	—	9.65	—	—	—	0.875 (J)	—	—	—	31.3 (J)	—

Notes: Values are in mg/kg. Values are maximum values >BV; if no BV, value is maximum detected value. Grey shading indicates a screening value was exceeded. 1 = EPA Region 6 SSLs: EPA (2007, 101002).

All values from EPA Region 6 HHMSLs and Region 9 preliminary remediation goals (PRGs) adjusted to TR 10-5.

^a Background values are from LANL (1998, 59730).

^b n/a = Not available.

^c SSLs are from EPA Region 9 PRGs: (<http://www.epa.gov/region09/waste/sfund/prg/files/04prgtable.pdf>); EPA Region 6 SSLs (2007, 101002) or NMED SSLs (2006, 92513).

^d — = Not detected, not detected >BV, or not analyzed.

**Table 6.2-2
Pajarito Sediment Organic COPCs**

Reach	Acenaphthene	Acenaphthylene (2)	Acetone	Amino-2,6-dinitrotoluene[4-] (3)	Amino-4,6-dinitrotoluene[2-] (3)	Aniline (1)	Anthracene	Aroclor-1242 ^a	Aroclor-1248 ^a	Aroclor-1254 ^a	Aroclor-1260 ^a	BHC[alpha-]	BHC[beta-]	BHC[gamma-]	Benzo[a]anthracene	Benzo[a]pyrene	Benzo[b]fluoranthene	Benzo[g,h,i]perylene	Benzo[k]fluoranthene	Benzoic Acid (1)	Bis[2-chloroethyl]ether	Bis[2-ethylhexyl]phthalate	Butanone[2-]
Residential SSL ^c	3730	2290	28100	61	61	85	22000	2.2	2.2	2.2	2.2	0.902	3.16	4.37	6.21	0.621	6.21	2290	62.1	100000	2.44	347	31800
AEN-1	— ^e	—	0.0595	—	—	0.211 (J)	0.01 (J)	—	—	—	0.114	—	—	—	0.0408	0.511	—	0.0221 (J+)	—	—	—	—	0.0144
AES-1	0.00538 (J)	—	0.0194	—	—	—	—	—	—	—	—	—	—	—	0.0147	—	—	—	—	—	—	—	—
AW-1	0.306	0.0204	—	—	—	—	0.257	—	—	2.63 (J+)	0.804 (J+)	—	—	—	0.67	0.707	1	0.408	0.235	0.672 (J)	—	0.418 (J-)	—
PA-0	—	—	—	0.86	0.4	—	—	—	—	—	—	—	—	—	—	—	—	—	—	3.5 (J)	—	—	—
PA-1E	—	—	—	—	—	—	—	—	—	—	0.0026 (J)	—	—	—	—	—	—	—	—	—	—	—	—
PA-1W	—	—	—	—	—	—	—	—	—	0.00217 (J)	0.00373	—	—	—	0.0157	—	—	—	—	—	—	—	—
PA-2W	—	—	0.0459	—	—	—	—	—	—	0.002 (J)	0.0066	—	—	—	0.0198	—	—	—	—	—	—	—	0.0019 (J)
PA-3E	—	—	—	—	—	—	0.069	—	—	0.0367	0.009	—	—	—	0.169	0.125	0.142	—	—	—	0.246 (J)	—	—
PA-4	0.0806	—	0.0385 (J)	—	—	—	0.0821	—	—	—	0.0357 (J)	—	—	—	0.169	0.138	0.219	0.0865	—	—	—	0.0399 (J)	0.0036 (J)
PA-4E	—	—	—	0.35	—	—	—	—	—	—	—	0.0016 (J)	—	—	—	—	—	—	—	0.61 (J)	—	—	—
PA-5W	0.0131 (J)	0.0137 (J)	--	—	—	—	0.0793	0.0258 (J)	0.0126	0.0348	0.0175	—	—	—	0.12	0.0912	—	0.0661	—	—	—	—	—
PAS-1E	—	—	—	—	—	—	0.00749 (J)	—	—	0.0041	0.0023 (J)	—	—	—	0.12	0.0484	—	0.031	—	—	—	—	—
PAS-2W	0.0816	—	0.0392	—	—	—	0.0834	—	—	0.0047	--	—	—	—	0.213	0.209	—	0.0657	—	0.571 (J)	—	—	0.0048 (J)
TH-1C	—	—	—	—	—	—	—	—	—	—	—	—	—	—	—	—	—	—	—	—	—	—	—
TH-1E	—	—	—	—	—	—	—	—	—	—	—	—	—	—	0.00775	—	—	—	—	—	0.473 (J)	—	—
TH-3	—	—	—	0.14 (J)	—	—	—	—	—	—	—	—	—	—	—	—	—	—	—	—	—	—	—
THM-1	—	—	0.008 (J)	—	—	—	—	—	—	0.0406	0.0253	—	—	—	—	—	—	—	—	—	0.529 (J)	0.341 (J)	1.27 (J-)
THS-1E	—	—	—	—	—	—	—	—	—	—	—	—	—	—	—	—	—	—	—	—	0.572 (J)	—	—
THS-1W	—	—	—	—	—	—	—	—	—	—	—	—	—	—	—	—	—	—	—	—	—	—	—
THW-1	—	—	—	—	—	—	—	—	—	—	—	—	—	—	—	—	—	—	—	—	—	—	—
TW-1E	—	—	0.0114	—	—	—	—	—	0.637	—	0.033 (J)	0.00346	--	0.00346 (J)	--	0.0992	0.0574	0.0864	—	0.57 (J)	—	—	—
TW-1W	—	—	—	—	—	—	—	—	—	—	0.0017 (J)	—	—	—	—	—	—	—	—	—	—	—	—
TW-2E	0.0718	—	—	—	—	—	0.0641	--	0.304	0.135	0.12	—	—	—	0.252	0.199	0.354	0.106	0.12	—	—	0.125 (J)	—
TW-3E	0.0199 (J)	—	—	—	—	—	0.0387	—	—	0.0545	0.0479	—	—	—	0.158	0.149	--	0.0929	—	—	—	—	—
TW-4E	—	—	0.0376	—	—	—	0.0244	—	—	0.0329	0.0196	—	—	—	0.121	0.103	0.176	0.0603	—	—	—	—	0.00623
TW-4W	—	—	—	—	—	—	0.0438	—	—	0.058	0.04 (J)	—	—	—	0.139	0.103	0.166	—	—	—	—	—	—
TWN-1E	30.7	—	0.0176 (J-)	—	—	—	30.7	—	0.0586	0.184	0.163	—	—	—	39.4	26.5	0.778	0.416	—	0.776 (J)	—	—	—

Table 6.2-2 (continued)

Reach	Acenaphthene	Acenaphthylene (2)	Acetone	Amino-2,6-dinitrotoluene[4-] (3)	Amino-4,6-dinitrotoluene[2-] (3)	Aniline (1)	Anthracene	Aroclor-1242 ^a	Aroclor-1248 ^a	Aroclor-1254 ^a	Aroclor-1260 ^a	BHC[alpha-]	BHC[beta-]	BHC[gamma-]	Benzo[a]anthracene	Benzo[a]pyrene	Benzo[b]fluoranthene	Benzo[g,h,i]perylene	Benzo[k]fluoranthene	Benzoic Acid (1)	Bis[2-chloroethyl]ether	Bis[2-ethylhexyl]phthalate	Butanone[2-]
TWN-1W	—	—	—	—	—	—	—	—	—	—	—	—	—	—	—	—	—	—	—	—	—	0.13 (J)	—
TWSE-1E	0.00791 (J)	—	—	—	—	—	0.00729 (J)	—	—	0.017 (J)	0.0072 (J)	—	—	—	0.0255	0.0211	—	—	—	0.73 (J)	—	0.63	—
TWSE-1W	—	—	—	—	—	—	—	—	—	—	0.034 (J)	—	—	—	—	—	—	—	—	—	—	—	—
TWSW-1E	—	—	—	—	0.076 (J)	—	—	—	—	0.003 (J)	—	—	—	—	—	—	—	—	—	—	—	—	—
TWSW-1W	—	—	—	—	—	—	0.00642 (J)	0.0044	—	0.003 (J)	0.002 (J)	—	—	—	—	—	—	—	—	—	—	—	—

Table 6.2-2 (continued)

Butylbenzene[n-]	Butylbenzylphthalate (1)	Carbon Disulfide (1)	Chlordane[alpha-] (9)	Chlordane[gamma-] (9)	Chloro-3-methylphenol[4-] (4)	Chloroform	Chloronaphthalene[2-]	Chrysene	DDD[4,4'-]	DDE[4,4'-]	DDT[4,4'-]	Di-n-butylphthalate	Dibenzofuran	Dichlorobenzene[1,3-]	Dichlorobenzene[1,4-]	Dichloroethane[1,2-]	Dichloroethene[1,1-]	Dieldrin	Dinitrotoluene[2,4-]	Dinitrotoluene[2,6-] (1)	Ethylbenzene
62.1	240	460	16.2	16.2	166	4	3990	615	24.4	17.2	17.2	6110	142	32.6	39.5	6.04	206	0.304	122	61	128
—	—	—	0.00593 (J)	0.00298 (J)	—	—	—	0.479	—	—	—	—	—	—	—	—	—	—	—	—	—
—	—	—	—	—	—	—	—	0.0121	—	—	0.00681 (J-)	—	—	—	—	—	0.00078 (J)	—	—	—	—
—	—	0.00379 (J)	—	—	—	—	—	0.592	—	0.00171 (J)	0.00257 (J)	1.54 (J-)	—	—	—	—	—	—	—	—	—
—	—	—	—	—	—	0.000324 (J)	—	—	—	0.0079	0.0092 (J)	—	—	—	—	—	—	—	—	—	—
—	—	—	—	—	—	—	—	0.0107	—	0.0036	0.00086 (J)	—	—	—	—	—	—	—	—	—	—
—	—	—	—	—	—	0.000408 (J+)	—	0.0112	—	—	—	—	—	—	—	—	—	—	—	—	—
—	—	—	—	—	—	0.000954 (J+)	—	0.0106	—	0.0021 (J)	—	—	—	—	—	—	—	—	—	—	—
—	—	—	—	—	—	0.000625 (J)	—	0.133	—	0.00307 (J)	—	—	—	—	0.00032 (J)	—	—	—	—	—	—
—	—	—	—	—	—	—	—	0.128	0.003 (J)	0.00632 (J)	—	0.104 (J)	—	—	—	—	—	0.00157 (J)	—	—	—
—	—	—	—	—	—	—	—	—	—	0.003 (J)	0.0065 (J)	—	—	—	—	—	—	—	—	—	—
—	—	0.0046 (J)	—	—	—	—	—	0.0953	—	0.00319 (J)	0.000366 (J)	—	—	—	—	—	—	—	—	—	—
—	—	—	—	—	—	—	—	0.0944	—	0.00404 (J)	0.0084 (J)	—	0.0774 (J)	—	—	0.00233	—	—	—	—	—
—	—	—	—	—	0.0432 (J)	—	0.0188 (J)	0.16	—	—	0.011 (J)	—	0.36	—	0.00024 (J)	—	0.00061 (J)	—	—	—	0.0028
—	—	—	—	—	—	0.000242 (J)	—	—	—	—	—	—	—	—	0.000309 (J)	—	—	—	—	—	—
—	—	—	—	—	—	—	—	0.00444	—	—	—	—	—	—	—	—	—	—	—	—	—
—	—	—	—	—	—	—	—	—	—	—	—	—	—	—	—	—	—	—	—	0.2 (J)	—
—	—	—	0.000245 (J)	—	—	—	—	—	—	—	—	—	—	—	—	—	—	—	—	—	—
—	—	—	—	—	—	—	—	—	—	—	—	—	—	—	0.0018	—	—	—	—	—	0.0014
0.000215 (J)	—	0.00171 (J)	—	—	—	0.000289 (J)	—	—	—	—	—	—	—	—	—	—	—	—	—	—	—
—	—	—	—	—	—	—	—	—	—	—	—	—	—	—	—	—	—	—	—	—	—
—	—	—	—	—	—	—	—	0.0216	—	0.0144	0.0304 (J)	—	—	—	—	—	0.0018	—	—	—	0.001 (J)
—	0.0831 (J)	0.004 (J)	—	—	—	—	—	—	—	0.00404 (J)	0.00597 (J)	—	—	—	—	—	0.00058 (J)	—	—	—	—
—	—	—	—	—	—	—	—	0.205	—	0.0024 (J)	—	—	—	—	—	—	—	—	0.32	—	—
—	—	0.0017 (J)	—	—	—	—	—	0.135	—	—	—	—	—	—	—	—	—	—	—	—	—
—	—	—	—	—	—	0.00328	—	0.133	—	—	—	—	—	—	—	—	—	—	—	—	—
—	—	—	—	—	—	—	—	0.0964	—	—	—	—	—	0.0075	—	—	—	—	—	—	—
—	—	—	—	—	—	0.00087 (J)	—	27	—	—	—	0.0486 (J)	0.146 (J)	—	—	—	0.0021 (J-)	—	—	—	0.0015 (J-)
—	—	—	—	—	—	0.000445 (J+)	—	—	—	—	—	—	—	—	—	—	—	—	—	—	—
—	—	—	—	—	—	—	—	0.021	—	—	—	—	—	—	0.00032 (J)	—	—	—	—	—	—
—	—	—	—	—	—	—	—	—	—	0.000417 (J)	—	—	—	—	—	—	—	—	—	—	—
—	—	—	—	—	—	—	—	—	—	—	—	—	—	—	—	—	—	—	—	—	—
—	—	—	—	—	—	—	—	0.0116	—	—	—	—	—	—	—	—	—	—	—	—	—

Table 6.2-2 (continued)

Fluoranthene	Fluorene	HMX	Heptachlor Epoxide (1)	1,2,3,4,6,7,8-HpCDD ^b	Total-HpCDD	1,2,3,4,6,7,8-HpCDF ^b	1,2,3,4,7,8,9-HpCDF	Total-HpCDF	1,2,3,4,7,8-HxCDD (e)	1,2,3,6,7,8-HxCDD (e)	1,2,3,7,8,9-HxCDD (e)	Total-HxCDD	1,2,3,4,7,8-HxCDF ^b	1,2,3,6,7,8-HxCDF ^b	1,2,3,7,8,9-HxCDF ^b	2,3,4,6,7,8-HxCDF ^b	Total-HxCDF
2290	2660	3060	0.53	3.90E-03	na ^d	3.90E-03	na	na	3.90E-04	3.90E-04	3.90E-04	na	3.90E-04	3.90E-04	3.90E-04	3.90E-04	na
1.03 (J+)	—	0.139 (J-)	—	—	—	—	—	—	—	—	—	—	—	—	—	—	—
0.0236	—	—	—	—	—	—	—	—	—	—	—	—	—	—	—	—	—
1.42	0.295	—	—	—	—	—	—	—	—	—	—	—	—	—	—	—	—
—	—	0.81 (J)	—	—	—	—	—	—	—	—	—	—	—	—	—	—	—
0.0153	—	—	—	—	—	—	—	—	—	—	—	—	—	—	—	—	—
0.0802	—	—	—	—	—	—	—	—	—	—	—	—	—	—	—	—	—
0.0362	—	—	—	—	—	—	—	—	—	—	—	—	—	—	—	—	—
0.331	—	—	—	0.0000508	0.000098	0.00000854	0.000000552 (J)	0.0000218	0.0000008 (J)	0.00000207 (J)	0.00000179 (J)	0.0000141	0.000000693 (J)	0.000000523 (J)	—	0.000000671 (J)	0.0000119
0.35	0.0726	—	—	—	—	—	—	—	—	—	—	—	—	—	—	—	—
—	—	—	—	—	—	—	—	—	—	—	—	—	—	—	—	—	—
0.294	0.0194	—	—	—	—	—	—	—	—	—	—	—	—	—	—	—	—
0.21	—	0.222 (J)	--	—	—	—	—	—	—	—	—	—	—	—	—	—	—
0.326	0.11	—	—	—	—	—	—	—	—	—	—	—	—	—	—	—	—
—	—	—	—	—	—	—	—	—	—	—	—	—	—	—	—	—	—
0.00837	—	—	—	—	—	—	—	—	—	—	—	—	—	—	—	—	—
—	—	—	—	—	—	—	—	—	—	—	—	—	—	—	—	—	—
0.0687	—	—	0.000546 (J)	—	—	—	—	—	—	—	—	—	—	—	—	—	—
0.0479	—	—	--	—	—	—	—	—	—	—	—	—	—	—	—	—	—
—	—	—	—	—	—	—	—	—	—	—	—	—	—	—	—	—	—
—	—	—	—	—	—	—	—	—	—	—	—	—	—	—	—	—	—
0.0519	—	—	—	0.0000238	0.0000404	0.0000113 (J)	0.000000665 (J)	0.0000175 (J)	0.00000164 (J)	0.0000025	0.00000281	0.0000221	0.00000142 (J)	0.000000865 (J)	0.000000341 (J)	0.00000106 (J)	0.00000865
—	—	—	—	0.0000133	0.0000224	0.00000216 (J)	—	0.00000675	—	0.000000553 (J)	0.000000333 (J)	0.00000281	0.000000243 (J)	—	—	0.000000143 (J)	0.00000269
0.539	0.0603	—	—	0.0000245	0.0000414	0.00000963	0.000000675 (J)	0.0000192	0.0000005 (J)	0.00000122 (J)	0.000000799 (J)	0.00000771	0.00000225 (J)	0.000000761 (J)	0.000000248 (J)	0.000000603 (J)	0.0000125 (J)
0.408	—	—	—	—	—	—	—	—	—	—	—	—	—	—	—	—	—
0.32	—	—	—	0.0000624	0.000109	0.000011	0.000000762 (J)	0.0000279	0.00000091 (J)	0.00000337	0.00000208 (J)	0.0000185	0.00000101 (J)	0.000000683 (J)	--	0.000000864 (J)	0.000016
0.31	0.0271	—	—	—	—	—	—	—	—	—	—	—	—	—	—	—	—
87.4	27	—	—	—	—	—	—	—	—	—	—	—	—	—	—	—	—
—	—	—	—	—	—	—	—	—	—	—	—	—	—	—	—	—	—
0.0494	—	—	—	—	—	—	—	—	—	—	—	—	—	—	—	—	—
0.0342	—	—	—	—	—	—	—	—	—	—	—	—	—	—	—	—	—
—	—	—	—	—	—	—	—	—	—	—	—	—	—	—	—	—	—
0.0273	—	—	—	—	—	—	—	—	—	—	—	—	—	—	—	—	—

Table 6.2-2 (continued)

Indeno[1,2,3-cd]pyrene	Isopropyltoluene[4-] (6)	Methyl-2-pentanone[4-]	Methylene Chloride	Methylnaphthalene[2-]	Methylphenol[4-] (5)	Naphthalene	Nitrobenzene	Nitrophenol[2-]	Nitrotoluene[2-]	Nitrotoluene[3-]	1,2,3,4,6,7,8,9-OCDD ^b	1,2,3,4,6,7,8,9-OCDF	1,2,3,7,8-PeCDD ^b	Total-PeCDD	1,2,3,7,8-PeCDF ^b	2,3,4,7,8-PeCDF ^b	Total-PeCDF	Phenanthrene
6.21	271	5510	182	79.5	3100	79.5	22.8	166	10.8	569	1.30E-01	1.30E-01	3.90E-05	na	1.30E-03	1.30E-04	n/a	1830
—	0.00089 (J)	—	—	0.0112 (J)	—	—	—	—	—	—	—	—	—	—	—	—	—	0.572 (J)
—	0.0095	—	—	0.0092 (J)	—	—	—	—	—	—	—	—	—	—	—	—	—	0.0281
—	—	—	—	0.0161 (J-)	0.192 (J)	0.138	—	—	—	—	—	—	—	—	—	—	—	1.57
—	—	—	—	—	0.9	—	0.15 (J)	—	0.44	—	—	—	—	—	—	—	—	—
—	—	—	0.00253 (J)	—	—	—	0.062 (J)	—	0.25	—	—	—	—	—	—	—	—	0.00994 (J)
—	0.00132 (J)	0.00372 (J+)	—	—	—	—	—	—	—	—	—	—	—	—	—	—	—	0.0702 (J)
—	0.565 (J)	0.002 (J)	—	—	—	—	—	—	—	—	—	—	—	—	—	—	—	0.0392
—	—	—	—	—	—	—	—	—	—	—	0.000385	0.0000178	0.000000371 (J)	0.00000162	—	0.00000053 (J)	0.00000606	0.328
0.0834	0.017	—	—	—	—	—	—	—	—	—	—	—	—	—	—	—	—	0.359
—	—	—	—	—	—	—	—	—	0.068 (J)	—	—	—	—	—	—	—	—	—
—	—	—	—	—	—	—	—	—	—	—	—	—	—	—	—	—	—	0.278
—	—	—	0.00364 (J)	0.0723	—	—	—	—	—	—	—	—	—	—	—	—	—	0.249
0.0709	0.0972	—	0.0053	0.434	—	0.0828	—	0.0347 (J)	—	—	—	—	—	—	—	—	—	0.43
—	0.0482	—	0.0151 (J)	—	—	—	—	—	—	—	—	—	—	—	—	—	—	—
—	—	—	—	—	—	—	—	—	—	—	—	—	—	—	—	—	—	—
—	—	—	—	—	—	—	—	—	—	—	—	—	—	—	—	—	—	—
—	0.00054 (J)	—	0.0031 (J)	—	—	—	—	—	—	—	—	—	—	—	—	—	—	0.0433
—	—	—	—	—	—	—	—	—	—	—	—	—	—	—	—	—	—	0.0508 (J)
—	—	—	—	—	—	—	—	—	—	—	—	—	—	—	—	—	—	—
0.0683	0.0013	—	—	—	—	—	—	—	—	—	0.0000675	0.00000906	0.00000178 (J)	0.0000122	0.00000171 (J)	0.00000293	0.0000196	0.0129 (J)
—	0.0062 (J)	—	0.0033 (J)	—	—	—	—	—	—	—	0.0001	0.00000711	—	0.000000362	—	—	0.00000112	—
—	—	—	—	—	—	—	—	—	—	0.12 (J)	0.000185	0.0000146	0.000000421 (J)	0.00000318	0.000000814 (J)	0.00000188 (J)	0.0000173	0.376
—	—	0.0013 (J)	0.00295 (J)	0.0138 (J)	—	—	—	—	—	—	—	—	—	—	—	—	—	0.26
—	0.00752	0.00119 (J)	0.00847	—	—	—	—	—	—	—	0.000513	0.000022	0.000000463 (J)	0.00000186	0.000000369 (J)	0.000000581 (J)	0.00000748	0.198
0.0585	—	—	—	—	—	—	—	—	—	—	—	—	—	—	—	—	—	0.205
0.429	—	—	—	0.083	—	42.7	—	—	—	—	—	—	—	—	—	—	—	116
—	0.00722 (J)	—	—	—	—	—	—	—	—	—	—	—	—	—	—	—	—	—
—	—	—	—	—	—	—	—	—	—	—	—	—	—	—	—	—	—	0.0532
—	0.283	0.0093	0.00454 (J)	—	—	—	—	—	—	—	—	—	—	—	—	—	—	0.175
—	—	—	—	—	—	—	—	—	—	—	—	—	—	—	—	—	—	—

Table 6.2-2 (continued)

Phenol	Pyrene	Pyridine (1)	RDX	Styrene	TATB (7)	2,3,7,8-TCDD ^b	Total-TCDD	2,3,7,8-TCDF ^b	Total-TCDF	Tetrachloroethene	Tetryl (5)	Toluene	Toxaphene [Technical Grade]	Trichloroethane[1,1,1-]	Trichloroethene	Trimethylbenzene[1,2,4-]	Trimethylbenzene[1,3,5-]	Trinitrotoluene[2,4,6-]	Xylenes[1,2-]	Xylenes[1,3-]+Xylenes[1,4-] (8)
18300	2290	61	44.2	100	30.6	3.90E-05	na	3.90E-04	na	12.5	240	252	4.42	563	0.638	58	24.8	30.6	82	82
—	0.926	—	—	—	4.37 (J-)	—	—	—	—	—	—	0.0026	—	—	—	—	—	—	—	—
—	0.0613	—	—	—	—	—	—	—	—	—	—	0.0039	—	—	—	—	—	—	—	—
0.426 (J-)	1.29	—	—	—	—	—	—	—	—	—	—	—	—	—	—	—	—	—	—	—
1.3	—	1	—	—	—	—	—	—	—	—	0.76	—	—	—	—	—	—	—	—	—
—	0.0135	—	—	—	0.689 (J)	—	—	—	—	—	—	—	—	—	—	—	—	—	—	—
—	0.0654	—	—	—	—	—	—	—	—	—	—	—	—	—	—	—	—	—	—	0.000455 (J-)
—	0.0388	—	—	—	0.553 (J)	—	—	—	—	—	—	0.0145	—	—	—	0.00023 (J)	—	0.11 (J)	—	0.00057 (J)
—	0.286	—	—	—	0.319 (J)	—	0.00000103	0.000000485 (J)	0.00000626	—	—	—	—	—	—	—	—	—	—	—
—	0.33	—	—	—	—	—	—	—	—	—	—	—	—	—	—	—	—	—	—	—
0.34 (J)	—	0.24 (J)	—	—	—	—	—	—	—	—	0.075 (J)	—	—	—	—	—	—	—	—	—
—	0.266	—	—	—	—	—	—	—	—	—	—	—	—	—	—	—	—	—	—	—
—	0.199	—	—	—	—	—	—	—	—	—	—	—	—	—	—	—	—	—	—	—
—	0.35	—	—	—	—	—	—	—	—	0.0011	—	0.0145	—	—	—	0.0054	—	—	0.0014	0.0088
—	—	—	—	—	—	—	—	—	—	—	—	0.00949	—	—	0.00267 (J)	—	—	—	—	—
—	0.00707	—	—	—	—	—	—	—	—	—	—	0.0017	—	—	—	—	—	—	—	—
—	—	—	—	—	—	—	—	—	—	—	0.25 (J)	—	—	—	—	—	—	—	—	—
—	0.057	—	—	—	—	—	—	—	—	—	—	0.0044	—	—	—	—	—	—	—	—
—	0.0657	—	—	—	—	—	—	—	—	0.0093	—	0.0034	—	—	0.00044 (J)	0.00091 (J)	—	—	0.0015	0.0056
—	0.00372 (J-)	—	—	—	—	—	—	—	—	—	—	—	—	—	—	—	0.000264 (J)	—	—	—
—	—	—	—	—	—	—	—	—	—	—	0.157 (J)	0.00158	—	—	—	—	—	—	—	—
—	0.0865	—	—	—	—	0.000000344 (J)	0.0000064	0.00000801	0.000135	—	—	0.0182	0.173 (J)	—	0.00069 (J)	0.00047 (J)	—	—	0.00042 (J)	0.003
—	—	—	—	—	—	—	0.00000149	--	0.000000749	—	—	0.0035 (J)	—	—	—	—	—	—	—	—
—	0.465	—	—	—	—	0.000000167 (J)	0.00000219	0.00000435	0.0000559	—	0.14 (J)	—	—	—	—	—	—	—	—	—
—	0.324	—	—	—	—	—	—	—	—	—	—	0.00575 (J)	—	0.000334 (J)	—	—	—	—	—	—
—	0.245	—	—	—	—	—	0.00000106	0.000000625 (J)	0.00000552	—	—	0.0121	—	—	—	0.000238 (J)	—	—	—	0.000399 (J)
—	0.258	—	—	—	—	—	—	—	—	0.00069 (J)	—	—	—	—	—	—	—	—	—	—
—	85	—	—	—	—	—	—	—	—	—	—	0.0116 (J-)	—	—	0.001 (J-)	0.00064 (J-)	—	—	0.00069 (J-)	0.0049 (J-)
—	—	—	—	0.00198	—	—	—	—	—	—	—	—	—	—	—	—	—	—	—	—

Table 6.2-2 (continued)

Phenol	Pyrene	Pyridine (1)	RDX	Styrene	TATB (7)	2,3,7,8-TCDD ^b	Total-TCDD	2,3,7,8-TCDF ^b	Total-TCDF	Tetrachloroethene	Tetryl (5)	Toluene	Toxaphene [Technical Grade]	Trichloroethane[1,1,1-]	Trichloroethene	Trimethylbenzene[1,2,4-]	Trimethylbenzene[1,3,5-]	Trinitrotoluene[2,4,6-]	Xylenes[1,2-]	Xylenes[1,3-]+Xylenes[1,4-] (8)
—	0.045	—	—	—	—	—	—	—	—	0.0015	—	0.0024	—	—	—	0.00027 (J)	—	—	—	0.00042 (J)
—	0.171	—	0.184 (J)	—	—	—	—	—	—	—	—	0.00917	—	—	—	—	—	—	—	0.000644 (J)
—	0.00293	—	—	—	—	—	—	—	—	—	—	—	—	—	—	—	—	—	—	—
—	0.0256	—	—	—	—	—	—	—	—	—	—	—	—	—	—	—	—	—	—	—

Notes: Values are in mg/kg. Values are maximum detected values. Grey shading indicates a screening value was exceeded. All values from EPA Region 6 HHMSSLs and Region 9 PRGs adjusted to TR 10⁻⁵ EPA Region 9 PRGs (<http://www.epa.gov/region09/waste/sfund/prg/files/04prgtable.pdf>). EPA Region 6 SSLs (2007, 101002). NMED SSLs (2006, 92513). The following numbers are used in this table: 1 = EPA Region 6 SSLs; 2 = pyrene surrogate, NMED SSLs; 3 = 2,6-dinitrotoluene, Region 6 SSLs; 4 = 2-chlorophenol surrogate, NMED SSLs; 5 = EPA Region 9 PRG; 6 = isopropylbenzene (cumene) surrogate, Region 6 SSLs; 7 = TNT surrogate, NMED SSLs; 8 = xylenes (total) surrogate, NMED SSLs; 9 = chlordane surrogate, NMED SSLs.

^a Ca endpoint SSLs from Region 6 HHMSSLs.

^b 2,3,7,8-hexachlorodibenzodioxin EPA Region 6 HHMSSL modified by World Health Organization (WHO) 2005 TEF (= SSL x TEF).

^c SSLs are from EPA Region 9 PRGs: (<http://www.epa.gov/region09/waste/sfund/prg/files/04prgtable.pdf>); EPA Region 6 SSLs (2007, 101002) or NMED SSLs (2006, 92513).

^d na = Not available.

^e — = Not detected or not analyzed.

**Table 6.2-3
Pajarito Sediment Radionuclide COPCs**

Reach	Americium-241	Cesium-134	Cesium-137	Plutonium-238	Plutonium-239/240	Thorium-228	Thorium-232	Tritium	Uranium-234	Uranium-235	Uranium-238
LANL sediment BV ^a	0.04	NA ^b	0.9	0.006	0.068	2.28	2.33	0.093	2.59	0.2	2.29
Residential SAL ^c	30	2.4	5.6	37	33	2.3	5	750	170	17	86
AEN-1	— ^d	—	0.932	—	—	—	—	0.205 (J-)	3.05	0.236	2.9
AES-1	—	—	—	—	—	—	—	—	—	—	—
AW-1	—	—	0.963	—	—	—	—	—	5.34	0.424	3.43
PA-0	0.069	—	4.92	0.488	3.75	—	—	—	—	—	—
PA-1E	0.0781	—	—	—	—	—	—	—	—	—	—
PA-1W	—	—	—	—	—	—	—	—	—	—	—
PA-2W	—	0.107	1.75	—	0.0574	—	—	0.5912875	—	—	3.1
PA-3E	0.0491	—	4.42	0.0134	0.158	—	—	0.336	—	—	2.31
PA-4	0.102	—	4.18	0.0432	0.187	2.37	—	—	—	—	—
PA-4E	—	—	1.81	—	—	—	—	—	—	—	—
PA-5W	—	—	1.62	—	0.086	—	—	—	—	—	—
PAS-1E	—	—	2.28	—	—	—	—	—	—	—	—
PAS-2W	—	0.119	—	—	—	—	—	—	—	—	—
TH-1C	—	—	0.981	—	—	—	—	—	3.48	0.25	4.84
TH-1E	—	—	1.27	—	—	—	—	0.12677546	5	0.391	6.63
TH-3	—	—	0.97	—	—	—	—	—	4.84	0.337	9.2
THM-1	—	—	1.08	—	—	—	—	5.19	8.9	1.32	51.5
THS-1E	—	—	—	—	—	3.03	2.57	0.93962866	8.36	0.823	20.3
THS-1W	—	—	—	—	—	—	—	—	21.3	1.25	46.3
THW-1	—	—	1.37	—	—	—	—	—	5.89	0.374	8
TW-1E	—	—	—	—	—	—	—	0.237	—	—	—
TW-2E	—	—	0.95	—	—	—	—	—	—	0.209	—
TW-3E	0.0795	—	0.987	—	—	—	—	—	—	—	—
TW-4E	—	—	0.908	—	0.0457	—	—	—	—	—	2.78
TW-4W	—	—	—	—	0.069	—	—	—	—	—	—
TWN-1E	—	—	2.37	—	0.105	—	—	—	—	—	—
TWN-1W	—	—	1.32	—	—	—	—	—	—	—	—
TWSE-1E	—	—	1.07	—	0.095	—	—	—	—	—	—
TWSE-1W	—	—	—	—	—	—	—	—	—	—	—
TWSW-1E	0.171	—	2.98	—	1.06	—	—	0.383	2.74	—	3.75
TWSW-1W	—	—	—	—	—	—	—	—	—	—	—

Notes: Values are in pCi/g. Values are maximum values > BV; if no BV, value is maximum detected value. Grey shading indicates a screening value was exceeded.

a Background values are from LANL (1998, 059730).

b NA = Not analyzed.

c SALs are from LANL (2005, 088493).

d — = Not detected, not detected > BV, or not analyzed.

**Table 6.3-1
Screening Table for Pajarito Watershed Metals in Alluvial Groundwater**

Constituent			Summary by Sample								Screening Values			Location Summary				
Metals	Field Prep	Units	Total	Detects (D)			Exceedances		GW Bkgd ^a	Screening Standard ^b		Locations with Data (Number)	D>Bkgd (number of locations)	D>Bkgd Station List ^c	D>Std (Number of locations)	D>Std Station List ^c		
				Number	Rate (%)	Min.	Median	Max.		D>Bkgd (Number)	D>Std (Number)						Level	Std Type
Aluminum	F	µg/L	61	45	73.8	77.8	513	3520	0	0	15670	5000	NMGSF	15	0	- ^d	0	-
Antimony	F	µg/L	61	1	1.64	0.5	0.5	0.5	0	0	10	6	MCL	15	0	-	0	-
Arsenic	F	µg/L	61	4	6.56	1.5	2.6	4.8	0	0	5	10	MCL	15	0	-	0	-
Barium	F	µg/L	61	61	100	53.3	90.9	320	55	0	68.57	1000	NMGSF	15	14	1, 3, 4, 5, 6, 8, 9, 10, 11, 12, 13, 14, 15, 16	0	-
Beryllium	F	µg/L	61	0	0	n/a ^e	n/a	n/a	0	0	2.5	4	MCL	15	0	-	0	-
Boron	F	µg/L	61	49	80.3	12.1	26.2	344	3	0	51.89	750	NMGSF	15	2	15, 16	0	-
Cadmium	F	µg/L	61	0	0	n/a	n/a	n/a	0	0	2.5	5	MCL	15	0	-	0	-
Chromium	F	µg/L	61	19	31.1	1.1	2	3.8	0	0	5	50	NMGSF	15	0	-	0	-
Cobalt	F	µg/L	61	13	21.3	1.1	1.8	9.6	3	0	5	50	NMGSF	15	3	5, 8, 15	0	-
Copper	F	µg/L	46	3	6.52	3.3	3.5	4	0	0	5	1000	NMGSF	15	0	-	0	-
Iron	F	µg/L	61	56	91.8	29.7	202	8600	1	4	8270	1000	NMGSF	15	1	8	3	1, 8, 15
Lead	F	µg/L	61	3	4.92	0.54	0.56	0.87	0	0	1.88	15	MCL	15	0	-	0	-
Manganese	F	µg/L	61	39	63.9	2.1	5	6040	0	9	21000	200	NMGSF	15	0	-	6	8, 10, 12, 14, 15, 16
Mercury	F	µg/L	61	5	8.2	0.034	0.064	4.1	2	1	0.1	2	MCL	15	1	5	1	5
Molybdenum	F	µg/L	61	17	27.9	0.42	1.1	9.5	2	0	5	1000	NMGSF	15	2	8, 10	0	-
Nickel	F	µg/L	61	58	95.1	0.55	0.935	11.9	2	0	10	100	MCL	15	1	16	0	-
Selenium	F	µg/L	61	0	0	n/a	n/a	n/a	0	0	3	50	NMGSF	15	0	-	0	-
Silver	F	µg/L	61	0	0	n/a	n/a	n/a	0	0	5	50	NMGSF	15	0	-	0	-
Strontium	F	µg/L	61	61	100	87.6	117	730	30	0	120	21900	Reg6	15	11	3, 4, 6, 8, 10, 11, 12, 13, 14, 15, 16	0	-
Thallium	F	µg/L	61	11	18	0.41	0.49	0.74	0	0	5	2	MCL	15	0	-	0	-
Tin	F	µg/L	61	1	1.64	3	3	3	0	0	5	21900	Reg6	15	0	-	0	-
Uranium	F	µg/L	61	20	32.8	0.05	0.255	3.6	4	0	1.03	30	NMGSF	15	1	16	0	-
Vanadium	F	µg/L	61	33	54.1	1	1.5	7.7	2	0	5	182.5	Reg6	15	2	15, 16	0	-
Zinc	F	µg/L	61	21	34.4	2.1	3.6	872	2	0	10	10000	NMGSF	15	2	10, 15	0	-
Aluminum	UF	µg/L	60	56	93.3	75.7	619	4680	n/a	0	na ^f	36500	Reg6	15	n/a	-	0	-
Antimony	UF	µg/L	60	0	0	n/a	n/a	n/a	n/a	0	na	6	MCL	15	n/a	-	0	-
Arsenic	UF	µg/L	60	9	15	1.6	2.2	3.2	n/a	0	na	10	MCL	15	n/a	-	0	-
Barium	UF	µg/L	60	60	100	61.8	94.85	326	n/a	0	na	2000	MCL	15	n/a	-	0	-
Beryllium	UF	µg/L	60	0	0	n/a	n/a	n/a	n/a	0	na	4	MCL	15	n/a	-	0	-
Boron	UF	µg/L	60	48	80	12.8	26.15	58.8	n/a	0	na	7300	Reg6	15	n/a	-	0	-

Table 6.3-1 (continued)

Constituent			Summary by Sample								Screening Values			Location Summary				
Metals	Field Prep	Units	Total	Detects (D)			Exceedances		GW Bkgd ^a	Screening Standard ^b		Locations with Data (Number)	D>Bkgd (number of locations)	D>Bkgd Station List ^c	D>Std (Number of locations)	D>Std Station List ^c		
				Number	Rate (%)	Min.	Median	Max.		D>Bkgd (Number)	D>Std (Number)						Level	Std Type
Cadmium	UF	µg/L	60	1	1.67	0.17	0.17	0.17	n/a	0	na	5	MCL	15	n/a	-	0	-
Chromium	UF	µg/L	60	32	53.3	1	2.7	15	n/a	0	na	100	MCL	15	n/a	-	0	-
Cobalt	UF	µg/L	60	4	6.67	1.3	1.7	9.8	n/a	0	na	730	Reg6	15	n/a	-	0	-
Copper	UF	µg/L	45	6	13.3	3.3	3.45	3.8	n/a	0	na	1300	MCL	15	n/a	-	0	-
Iron	UF	µg/L	60	60	100	46.5	304.5	8620	n/a	0	na	25550	Reg6	15	n/a	-	0	-
Lead	UF	µg/L	60	17	28.3	0.58	1	3.3	n/a	0	na	15	Reg6	15	n/a	-	0	-
Manganese	UF	µg/L	60	48	80	2	7.6	5970	n/a	1	na	1703.09	Reg6	15	n/a	-	1	8
Mercury	UF	µg/L	60	5	8.33	0.042	0.12	6.7	5	1	0.03	2	NMGSU	15	5	1, 3, 5, 11, 16	1	5
Molybdenum	UF	µg/L	60	18	30	0.38	1.05	8.1	n/a	0	na	182.5	Reg6	15	n/a	-	0	-
Nickel	UF	µg/L	60	58	96.7	0.54	1.1	13.1	n/a	0	na	100	MCL	15	n/a	-	0	-
Selenium	UF	µg/L	60	1	1.67	1.1	1.1	1.1	0	0	3	50	MCL	15	0	-	0	-
Silver	UF	µg/L	60	0	0	n/a	n/a	n/a	n/a	0	na	182.5	Reg6	15	n/a	-	0	-
Strontium	UF	µg/L	60	60	100	87.9	118	743	n/a	0	na	21900	Reg6	15	n/a	-	0	-
Thallium	UF	µg/L	60	7	11.7	0.37	0.4	0.49	n/a	0	na	2	MCL	15	n/a	-	0	-
Tin	UF	µg/L	60	3	5	2.7	2.8	2.8	n/a	0	na	21900	Reg6	15	n/a	-	0	-
Uranium	UF	µg/L	60	31	51.7	0.05	0.17	5.3	n/a	0	na	30	MCL	15	n/a	-	0	-
Vanadium	UF	µg/L	60	41	68.3	1.1	2.1	7.7	n/a	0	na	182.5	Reg6	15	n/a	-	0	-
Zinc	UF	µg/L	60	29	48.3	2	3.5	520	n/a	0	na	10950	Reg6	15	n/a	-	0	-

Notes: Light grey indicates exceeds groundwater background. Dark grey indicates exceeds standard.

^aGroundwater background UTL or maximum detect for alluvial groundwater filtered samples; LANL "Groundwater Background Investigation Report, Revision 3" (2007, 095817).

^bScreening Standard
 Std Type Standard (Source and Name)
 NMGSF NMAC 20.6.2, Groundwater Standards (Filtered)
 NMGSU NMAC 20.6.2, Groundwater Standards (Unfiltered)
 NMRPS New Mexico Environmental Improvement Board (NMEIB) Radiation Protection Standards
 MCL EPA MCL
 SMCL EPA Secondary Maximum Contaminant Level (SMCL)
 Reg6 EPA Region 6 Tap Water Screening Level
 DCG DOE 4-mrem DCG

^cStation List (codes)
 1 = 18-BG-1 9 = PCAO-7a
 2 = 18-BG-4 10 = PCAO-7b2
 3 = 18-MW-11 11 = PCAO-7c
 4 = 18-MW-18 12 = PCAO-8
 5 = 18-MW-8 13 = PCAO-9
 6 = 18-MW-9 14 = PCO-1
 7 = 3MAO-2 15 = PCO-2
 8 = PCAO-5 16 = PCO-3

^d - = None.
^e n/a = Not applicable.
^f na = Not available (no published value).

**Table 6.3-2
Screening Table for Pajarito Watershed Radionuclides in Alluvial Groundwater**

Constituent			Summary by Sample								Screening Values			Location Summary				
Radionuclides	Field Prep	Units	Total	Detects (D)			Exceedances		GW Bkgd ^a	Screening Standard ^b		Locations with Data (Number)	D>Bkgd (Number of Locations)	D>Bkgd Station List ^c	D>Std (Number of Locations)	D>Std Station List ^c		
				Number	Rate (%)	Min.	Median	Max.		D>Bkgd (Number)	D>Std (Number)						Level	Level
Americium-241	F	pCi/L	57	1	1.75	0.0917	0.0917	0.0917	0	0	0.75	20	NMRPS	14	0	- ^d	0	-
Cesium-137	F	pCi/L	58	1	1.72	9.39	9.39	9.39	1	0	0.34	1000	NMRPS	14	1	15	0	-
Cobalt-60	F	pCi/L	58	0	0	n/a ^e	n/a	n/a	n/a	0	na	3000	NMRPS	14	n/a	-	0	-
Gross alpha	F	pCi/L	32	3	9.38	1.02	1.26	5.23	n/a	0	na	15	MCL	8	n/a	-	0	-
Gross beta	F	pCi/L	32	31	96.9	2.69	5.17	9.22	n/a	0	na	50	SMCL	8	n/a	-	0	-
Gross gamma	F	pCi/L	58	0	0	n/a	n/a	n/a	n/a	n/a	na	na ^f	na	14	n/a	-	n/a	-
Neptunium-237	F	pCi/L	56	0	0	n/a	n/a	n/a	n/a	0	na	20	NMRPS	14	n/a	-	0	-
Plutonium-238	F	pCi/L	58	0	0	n/a	n/a	n/a	n/a	0	0	20	NMRPS	14	0	-	0	-
Plutonium-239/240	F	pCi/L	56	1	1.79	0.0213	0.0213	0.0213	n/a	0	na	20	NMRPS	14	n/a	-	0	-
Potassium-40	F	pCi/L	54	1	1.85	53.9	53.9	53.9	n/a	0	na	4000	NMRPS	14	n/a	-	0	-
Sodium-22	F	pCi/L	58	0	0	n/a	n/a	n/a	n/a	0	na	6000	NMRPS	14	n/a	-	0	-
Strontium-90	F	pCi/L	58	4	6.9	0.375	0.5365	0.72	4	0	0.06	8	MCL	14	3	13, 15, 16	0	-
Uranium-234	F	pCi/L	58	19	32.8	0.0453	0.169	1.15	10	0	0.16	300	NMRPS	14	3	4, 8, 16	0	-
Uranium-235/236	F	pCi/L	58	3	5.17	0.046	0.0862	0.155	NA	0	na	na	na	14	n/a	-	n/a	-
Uranium-238	F	pCi/L	58	16	27.6	0.0474	0.1043	1.23	7	0	0.12	300	NMRPS	14	2	4, 16	0	-
Americium-241	UF	pCi/L	59	0	0	n/a	n/a	n/a	n/a	0	na	20	NMRPS	14	n/a	-	0	-
Cesium-137	UF	pCi/L	59	0	0	n/a	n/a	n/a	n/a	0	na	1000	NMRPS	14	n/a	-	0	-
Cobalt-60	UF	pCi/L	59	0	0	n/a	n/a	n/a	n/a	0	na	3000	NMRPS	14	n/a	-	0	-
Gross alpha	UF	pCi/L	33	10	30.3	0.711	1.535	4.58	n/a	0	na	15	MCL	8	n/a	-	0	-
Gross beta	UF	pCi/L	33	32	97	2.73	5.225	9.26	n/a	0	na	50	SMCL	8	n/a	-	0	-
Gross gamma	UF	pCi/L	59	2	3.39	122	197.5	273	n/a	n/a	na	na	na	14	n/a	-	n/a	-
Neptunium-237	UF	pCi/L	58	0	0	n/a	n/a	n/a	n/a	0	na	20	NMRPS	14	n/a	-	0	-
Plutonium-238	UF	pCi/L	59	0	0	n/a	n/a	n/a	n/a	0	na	20	NMRPS	14	n/a	-	0	-
Plutonium-239/240	UF	pCi/L	59	0	0	n/a	n/a	n/a	n/a	0	na	20	NMRPS	14	n/a	-	0	-
Potassium-40	UF	pCi/L	54	0	0	n/a	n/a	n/a	n/a	0	na	4000	NMRPS	14	n/a	-	0	-
Radium-226	UF	pCi/L	19	10	52.6	0.454	0.734	1.71	n/a	0	na	5	MCL	12	n/a	-	0	-
Radium-228	UF	pCi/L	20	6	30	0.446	0.8145	1.25	n/a	0	na	5	MCL	13	n/a	-	0	-
Sodium-22	UF	pCi/L	59	0	0	n/a	n/a	n/a	n/a	0	na	6000	NMRPS	14	n/a	-	0	-

Table 6.3-2 (continued)

Constituent			Summary by Sample								Screening Values			Location Summary				
Radionuclides	Field Prep	Units	Total	Detects (D)			Exceedances		GW Bkgd ^a	Screening Standard ^b		Locations with Data (Number)	D>Bkgd (Number of Locations)	D>Bkgd Station List ^c	D>Std (Number of Locations)	D>Std Station List ^c		
				Number	Rate (%)	Min.	Median	Max.		D>Bkgd (Number)	D>Std (Number)						Level	Std Type
Strontium-90	UF	pCi/L	59	3	5.08	0.491	0.577	0.645	n/a	0	na	8	MCL	14	n/a	-	0	-
Tritium	UF	pCi/L	52	49	94.2	24.17	68.97	105.7	36	0	57.28	20000	MCL	12	11	1, 3, 4, 5, 6, 7, 9, 11, 12, 15, 16	0	-
Uranium-234	UF	pCi/L	59	21	35.6	0.0641	0.189	1.86	n/a	0	na	300	NMRPS	14	n/a	-	0	-
Uranium-235/236	UF	pCi/L	59	2	3.39	0.0652	0.0704	0.0756	n/a	n/a	na	na	na	14	n/a	-	n/a	-

Notes: Light grey indicates exceeds groundwater background. Dark grey indicates exceeds standard.

^a Groundwater background UTL or maximum detect for alluvial groundwater filtered samples; LANL "Groundwater Background Investigation Report, Revision 3" (2007, 095817).

^b Screening Standard

Std Type	Standard (Source and Name)
NMGSF	NMAC 20.6.2, Groundwater Standards (Filtered)
NMGSU	NMAC 20.6.2, Groundwater Standards (Unfiltered)
NMRPS	NMEIB Radiation Protection Standards
MCL	EPA MCL
SMCL	EPA SMCL
Reg6	EPA Region 6 Tap Water Screening Level
DCG	DOE 4-mrem DCG

^c Station List (codes)

1 = 18-BG-1	9 = PCAO-7a
2 = 18-BG-4	10 = PCAO-7b2
3 = 18-MW-11	11 = PCAO-7c
4 = 18-MW-18	12 = PCAO-8
5 = 18-MW-8	13 = PCAO-9
6 = 18-MW-9	14 = PCO-1
7 = 3MAO-2	15 = PCO-2
8 = PCAO-5	16 = PCO-3

^d - = None.

^e n/a = Not applicable.

^f na = Not available (no published value).

Table 6.3-3
Screening Table for Pajarito Watershed Organics in Alluvial Groundwater

Constituent			Summary by Sample								Screening Values			Location Summary				
Organics	Field Prep	Units	Total	Detects (D)			Exceedances		GW Bkgd ^a	Screening Standard ^b		Locations with Data (Number)	D>Bkgd (Number of Locations)	D>Bkgd Station List ^c	D>Std (Number of Locations)	D>Std Station List ^c		
				Number	Rate (%)	Min.	Median	Max.		D>Bkgd (Number)	D>Std (Number)						Level	Level
2,4-Diamino-6-nitrotoluene	UF	µg/L	61	0	0	n/a ^d	n/a	n/a	n/a	n/a	na ^e	na	na	16	n/a	- ^f	n/a	-
2,6-Diamino-4-nitrotoluene	UF	µg/L	59	0	0	n/a	n/a	n/a	n/a	n/a	na	na	na	16	n/a	-	n/a	-
3,5-Dinitroaniline	UF	µg/L	61	0	0	n/a	n/a	n/a	n/a	n/a	na	na	na	16	n/a	-	n/a	-
Acenaphthene	UF	µg/L	59	0	0	n/a	n/a	n/a	n/a	0	na	365	Reg6	14	n/a	-	0	-
Acenaphthylene	UF	µg/L	59	0	0	n/a	n/a	n/a	n/a	n/a	na	na	na	14	n/a	-	n/a	-
Acetone	UF	µg/L	57	8	14	1.25	2.415	22.2	n/a	0	na	5475	Reg6	16	n/a	-	0	-
Acetonitrile	UF	µg/L	49	1	2.04	11.6	11.6	11.6	n/a	0	na	124.1	Reg6	15	n/a	-	0	-
Acrolein	UF	µg/L	55	0	0	n/a	n/a	n/a	n/a	0	na	0.0416	Reg6	16	n/a	-	0	-
Acrylonitrile	UF	µg/L	61	0	0	n/a	n/a	n/a	n/a	0	na	1.237	Reg6	16	n/a	-	0	-
Aldrin	UF	µg/L	59	1	1.69	0.0124	0.0124	0.0124	n/a	0	na	0.0395	Reg6	14	n/a	-	0	-
Amino-2,6-dinitrotoluene[4-]	UF	µg/L	61	0	0	n/a	n/a	n/a	n/a	n/a	na	na	na	16	n/a	-	n/a	-
Amino-4,6-dinitrotoluene[2-]	UF	µg/L	61	0	0	n/a	n/a	n/a	n/a	n/a	na	na	na	16	n/a	-	n/a	-
Aniline	UF	µg/L	59	0	0	n/a	n/a	n/a	n/a	0	na	117.95	Reg6	14	n/a	-	0	-
Anthracene	UF	µg/L	59	0	0	n/a	n/a	n/a	n/a	0	na	1825	Reg6	14	n/a	-	0	-
Aroclor-1016	UF	µg/L	59	0	0	n/a	n/a	n/a	n/a	0	na	0.5	MCL	14	n/a	-	0	-
Aroclor-1221	UF	µg/L	59	0	0	n/a	n/a	n/a	n/a	0	na	0.5	MCL	14	n/a	-	0	-
Aroclor-1232	UF	µg/L	59	0	0	n/a	n/a	n/a	n/a	0	na	0.5	MCL	14	n/a	-	0	-
Aroclor-1242	UF	µg/L	59	0	0	n/a	n/a	n/a	n/a	0	na	0.5	MCL	14	n/a	-	0	-
Aroclor-1248	UF	µg/L	59	0	0	n/a	n/a	n/a	n/a	0	na	0.5	MCL	14	n/a	-	0	-
Aroclor-1254	UF	µg/L	59	0	0	n/a	n/a	n/a	n/a	0	na	0.5	MCL	14	n/a	-	0	-
Aroclor-1260	UF	µg/L	59	1	1.69	0.098	0.098	0.098	n/a	0	na	0.5	MCL	14	n/a	-	0	-
Aroclor-1262	UF	µg/L	59	0	0	n/a	n/a	n/a	n/a	0	na	0.5	MCL	14	n/a	-	0	-
Atrazine	UF	µg/L	52	0	0	n/a	n/a	n/a	n/a	0	na	3	MCL	13	n/a	-	0	-
Azobenzene	UF	µg/L	59	0	0	n/a	n/a	n/a	n/a	0	na	6.112	Reg6	14	n/a	-	0	-
BHC[alpha-]	UF	µg/L	59	1	1.69	0.0127	0.0127	0.0127	n/a	0	na	0.1067	Reg6	14	n/a	-	0	-
BHC[beta-]	UF	µg/L	59	1	1.69	0.0383	0.0383	0.0383	n/a	0	na	0.3735	Reg6	14	n/a	-	0	-
BHC[delta-]	UF	µg/L	59	1	1.69	0.027	0.027	0.027	n/a	n/a	na	na	na	14	n/a	-	n/a	-
BHC[gamma-]	UF	µg/L	59	1	1.69	0.0102	0.0102	0.0102	n/a	0	na	0.2	MCL	14	n/a	-	0	-
Benzene	UF	µg/L	60	0	0	n/a	n/a	n/a	n/a	0	na	5	MCL	16	n/a	-	0	-
Benidine	UF	µg/L	48	0	0	n/a	n/a	n/a	n/a	0	na	0.000936	Reg6	13	n/a	-	0	-
Benzo[a]anthracene	UF	µg/L	59	0	0	n/a	n/a	n/a	n/a	0	na	0.295	Reg6	14	n/a	-	0	-
Benzo[a]pyrene	UF	µg/L	59	0	0	n/a	n/a	n/a	n/a	0	na	0.2	MCL	14	n/a	-	0	-
Benzo[b]fluoranthene	UF	µg/L	59	0	0	n/a	n/a	n/a	n/a	0	na	0.295	Reg6	14	n/a	-	0	-
Benzo[g,h,i]perylene	UF	µg/L	59	0	0	n/a	n/a	n/a	n/a	n/a	na	na	na	14	n/a	-	n/a	-
Benzo[k]fluoranthene	UF	µg/L	59	0	0	n/a	n/a	n/a	n/a	0	na	2.95	Reg6	14	n/a	-	0	-

Table 6.3-3 (continued)

Constituent			Summary by Sample								Screening Values			Location Summary				
Organics	Field Prep	Units	Total	Detects (D)			Exceedances		GW Bkgd ^a	Screening Standard ^b		Locations with Data (Number)	D>Bkgd (Number of Locations)	D>Bkgd Station List ^c	D>Std (Number of Locations)	D>Std Station List ^c		
				Number	Rate (%)	Min.	Median	Max.		D>Bkgd (Number)	D>Std (Number)						Level	Level
Benzoic Acid	UF	µg/L	52	0	0	n/a	n/a	n/a	n/a	0	na	146000	Reg6	14	n/a	-	0	-
Benzyl Alcohol	UF	µg/L	59	0	0	n/a	n/a	n/a	n/a	0	na	10950	Reg6	14	n/a	-	0	-
Bis[2-chloroethoxy]methane	UF	µg/L	59	0	0	n/a	n/a	n/a	n/a	n/a	na	na	na	14	n/a	-	n/a	-
Bis[2-chloroethyl]ether	UF	µg/L	59	0	0	n/a	n/a	n/a	n/a	0	na	0.602	Reg6	14	n/a	-	0	-
Bis[2-ethylhexyl]phthalate	UF	µg/L	59	1	1.69	6.85	6.85	6.85	n/a	1	na	6	MCL	14	n/a	-	1	6
Bromobenzene	UF	µg/L	61	0	0	n/a	n/a	n/a	n/a	0	na	23.25	Reg6	16	n/a	-	0	-
Bromochloromethane	UF	µg/L	61	0	0	n/a	n/a	n/a	n/a	n/a	na	na	na	16	n/a	-	n/a	-
Bromodichloromethane	UF	µg/L	61	0	0	n/a	n/a	n/a	n/a	0	na	10.69	Reg6	16	n/a	-	0	-
Bromoform	UF	µg/L	61	0	0	n/a	n/a	n/a	n/a	0	na	85.1	Reg6	16	n/a	-	0	-
Bromomethane	UF	µg/L	61	0	0	n/a	n/a	n/a	n/a	0	na	8.66	Reg6	16	n/a	-	0	-
Bromophenyl-phenylether[4-]	UF	µg/L	59	0	0	n/a	n/a	n/a	n/a	n/a	na	na	na	14	n/a	-	n/a	-
Butanol[1-]	UF	µg/L	18	2	11.1	13.9	55.4	96.9	n/a	0	na	3650	Reg6	10	n/a	-	0	-
Butanone[2-]	UF	µg/L	61	1	1.64	1.67	1.67	1.67	n/a	0	na	7064.5	Reg6	16	n/a	-	0	-
Butylbenzene[n-]	UF	µg/L	61	0	0	n/a	n/a	n/a	n/a	0	na	60.83	Reg6	16	n/a	-	0	-
Butylbenzene[sec-]	UF	µg/L	61	0	0	n/a	n/a	n/a	n/a	0	na	60.83	Reg6	16	n/a	-	0	-
Butylbenzene[tert-]	UF	µg/L	61	0	0	n/a	n/a	n/a	n/a	0	na	60.83	Reg6	16	n/a	-	0	-
Butylbenzylphthalate	UF	µg/L	59	0	0	n/a	n/a	n/a	n/a	0	na	7300	Reg6	14	n/a	-	0	-
Carbon Disulfide	UF	µg/L	60	0	0	n/a	n/a	n/a	n/a	0	na	1042.9	Reg6	16	n/a	-	0	-
Carbon Tetrachloride	UF	µg/L	61	0	0	n/a	n/a	n/a	n/a	0	na	5	MCL	16	n/a	-	0	-
Chlordane[alpha-]	UF	µg/L	59	0	0	n/a	n/a	n/a	n/a	0	na	2	MCL	14	n/a	-	0	-
Chlordane[gamma-]	UF	µg/L	59	0	0	n/a	n/a	n/a	n/a	n/a	na	na	na	14	n/a	-	n/a	-
Chloro-1,3-butadiene[2-]	UF	µg/L	61	0	0	n/a	n/a	n/a	n/a	0	na	14.31	Reg6	16	n/a	-	0	-
Chloro-1-propene[3-]	UF	µg/L	61	0	0	n/a	n/a	n/a	n/a	0	na	1825	Reg6	16	n/a	-	0	-
Chloro-3-methylphenol[4-]	UF	µg/L	52	0	0	n/a	n/a	n/a	n/a	n/a	na	na	na	14	n/a	-	n/a	-
Chloroaniline[4-]	UF	µg/L	59	0	0	n/a	n/a	n/a	n/a	0	na	146	Reg6	14	n/a	-	0	-
Chlorobenzene	UF	µg/L	61	0	0	n/a	n/a	n/a	n/a	0	na	100	MCL	16	n/a	-	0	-
Chlorodibromomethane	UF	µg/L	61	0	0	n/a	n/a	n/a	n/a	0	na	7.89	Reg6	16	n/a	-	0	-
Chloroethane	UF	µg/L	61	0	0	n/a	n/a	n/a	n/a	0	na	228.6	Reg6	16	n/a	-	0	-
Chloroethyl vinyl ether[2-]	UF	µg/L	16	0	0	n/a	n/a	n/a	n/a	n/a	na	na	na	13	n/a	-	n/a	-
Chloroform	UF	µg/L	61	0	0	n/a	n/a	n/a	n/a	0	na	60	MCL	16	n/a	-	0	-
Chloromethane	UF	µg/L	58	0	0	n/a	n/a	n/a	n/a	0	na	21.35	Reg6	16	n/a	-	0	-
Chloronaphthalene[2-]	UF	µg/L	59	0	0	n/a	n/a	n/a	n/a	0	na	486.7	Reg6	14	n/a	-	0	-
Chlorophenol[2-]	UF	µg/L	52	0	0	n/a	n/a	n/a	n/a	0	na	30.417	Reg6	14	n/a	-	0	-
Chlorophenyl-phenyl[4-] Ether	UF	µg/L	59	0	0	n/a	n/a	n/a	n/a	n/a	na	na	na	14	n/a	-	n/a	-
Chlorotoluene[2-]	UF	µg/L	57	0	0	n/a	n/a	n/a	n/a	0	na	121.67	Reg6	16	n/a	-	0	-

Table 6.3-3 (continued)

Constituent			Summary by Sample								Screening Values			Location Summary				
Organics	Field Prep	Units	Total	Detects (D)			Exceedances		GW Bkgd ^a	Screening Standard ^b		Locations with Data (Number)	D>Bkgd (Number of Locations)	D>Bkgd Station List ^c	D>Std (Number of Locations)	D>Std Station List ^c		
				Number	Rate (%)	Min.	Median	Max.		D>Bkgd (Number)	D>Std (Number)						Level	Level
Chlorotoluene[4-]	UF	µg/L	61	0	0	n/a	n/a	n/a	n/a	n/a	na	na	na	16	n/a	-	n/a	-
Chrysene	UF	µg/L	59	0	0	n/a	n/a	n/a	n/a	0	na	0.2	MCL	14	n/a	-	0	-
DB[2,4-]	UF	µg/L	19	0	0	n/a	n/a	n/a	n/a	0	na	292	Reg6	13	n/a	-	0	-
DDD[4,4'-]	UF	µg/L	59	4	6.78	0.00636	0.01246	0.0448	n/a	0	na	2.801	Reg6	14	n/a	-	0	-
DDE[4,4'-]	UF	µg/L	59	4	6.78	0.0103	0.01745	0.0321	n/a	0	na	1.977	Reg6	14	n/a	-	0	-
DDT[4,4'-]	UF	µg/L	59	2	3.39	0.0163	0.02915	0.042	n/a	0	na	1.977	Reg6	14	n/a	-	0	-
DNX	UF	µg/L	58	0	0	n/a	n/a	n/a	n/a	n/a	na	na	na	15	n/a	-	n/a	-
D[2,4-]	UF	µg/L	19	0	0	n/a	n/a	n/a	n/a	0	na	70	MCL	13	n/a	-	0	-
Dalapon	UF	µg/L	19	0	0	n/a	n/a	n/a	n/a	0	na	200	MCL	13	n/a	-	0	-
Di-n-butylphthalate	UF	µg/L	57	0	0	n/a	n/a	n/a	n/a	0	na	3650	Reg6	14	n/a	-	0	-
Di-n-octylphthalate	UF	µg/L	59	0	0	n/a	n/a	n/a	n/a	n/a	na	na	na	14	n/a	-	n/a	-
Dibenz[a,h]anthracene	UF	µg/L	59	0	0	n/a	n/a	n/a	n/a	0	na	0.0295	Reg6	14	n/a	-	0	-
Dibenzofuran	UF	µg/L	59	0	0	n/a	n/a	n/a	n/a	0	na	12.167	Reg6	14	n/a	-	0	-
Dibromo-3-Chloropropane[1,2-]	UF	µg/L	61	0	0	n/a	n/a	n/a	n/a	0	na	0.2	MCL	16	n/a	-	0	-
Dibromoethane[1,2-]	UF	µg/L	61	0	0	n/a	n/a	n/a	n/a	0	na	0.05	MCL	16	n/a	-	0	-
Dibromomethane	UF	µg/L	61	0	0	n/a	n/a	n/a	n/a	0	na	60.83	Reg6	16	n/a	-	0	-
Dicamba	UF	µg/L	19	0	0	n/a	n/a	n/a	n/a	0	na	1095	Reg6	13	n/a	-	0	-
Dichlorobenzene[1,2-]	UF	µg/L	61	0	0	n/a	n/a	n/a	n/a	0	na	600	MCL	16	n/a	-	0	-
Dichlorobenzene[1,3-]	UF	µg/L	61	0	0	n/a	n/a	n/a	n/a	0	na	600	MCL	16	n/a	-	0	-
Dichlorobenzene[1,4-]	UF	µg/L	61	0	0	n/a	n/a	n/a	n/a	0	na	75	MCL	16	n/a	-	0	-
Dichlorobenzidine[3,3'-]	UF	µg/L	59	0	0	n/a	n/a	n/a	n/a	0	na	1.494	Reg6	14	n/a	-	0	-
Dichlorodifluoromethane	UF	µg/L	61	0	0	n/a	n/a	n/a	n/a	0	na	394.6	Reg6	16	n/a	-	0	-
Dichloroethane[1,1-]	UF	µg/L	61	0	0	n/a	n/a	n/a	n/a	0	na	25	NMGSU	16	n/a	-	0	-
Dichloroethane[1,2-]	UF	µg/L	61	0	0	n/a	n/a	n/a	n/a	0	na	5	MCL	16	n/a	-	0	-
Dichloroethene[1,1-]	UF	µg/L	61	0	0	n/a	n/a	n/a	n/a	0	na	5	NMGSU	16	n/a	-	0	-
Dichloroethene[cis-1,2-]	UF	µg/L	61	0	0	n/a	n/a	n/a	n/a	0	na	70	MCL	16	n/a	-	0	-
Dichloroethene[trans-1,2-]	UF	µg/L	61	0	0	n/a	n/a	n/a	n/a	0	na	100	MCL	16	n/a	-	0	-
Dichlorophenol[2,4-]	UF	µg/L	49	0	0	n/a	n/a	n/a	n/a	0	na	109.5	Reg6	14	n/a	-	0	-
Dichloropropane[1,2-]	UF	µg/L	61	0	0	n/a	n/a	n/a	n/a	0	na	5	MCL	16	n/a	-	0	-
Dichloropropane[1,3-]	UF	µg/L	61	0	0	n/a	n/a	n/a	n/a	n/a	na	na	na	16	n/a	-	n/a	-
Dichloropropane[2,2-]	UF	µg/L	61	0	0	n/a	n/a	n/a	n/a	n/a	na	na	na	16	n/a	-	n/a	-
Dichloropropene[1,1-]	UF	µg/L	61	0	0	n/a	n/a	n/a	n/a	n/a	na	na	na	16	n/a	-	n/a	-
Dichloropropene[cis-1,3-]	UF	µg/L	61	0	0	n/a	n/a	n/a	n/a	n/a	na	na	na	16	n/a	-	n/a	-
Dichloropropene[cis/trans-1,3-]	UF	µg/L	5	0	0	n/a	n/a	n/a	n/a	0	na	6.71	Reg6	5	n/a	-	0	-
Dichloropropene[trans-1,3-]	UF	µg/L	61	0	0	n/a	n/a	n/a	n/a	n/a	na	na	na	16	n/a	-	n/a	-
Dichlorprop	UF	µg/L	19	0	0	n/a	n/a	n/a	n/a	n/a	na	na	na	13	n/a	-	n/a	-
Dieldrin	UF	µg/L	59	2	3.39	0.0119	0.0223	0.0327	n/a	0	na	0.04202	Reg6	14	n/a	-	0	-

Table 6.3-3 (continued)

Constituent			Summary by Sample								Screening Values			Location Summary				
Organics	Field Prep	Units	Total	Detects (D)			Exceedances		GW Bkgd ^a	Screening Standard ^b		Locations with Data (Number)	D>Bkgd (Number of Locations)	D>Bkgd Station List ^c	D>Std (Number of Locations)	D>Std Station List ^c		
				Number	Rate (%)	Min.	Median	Max.		D>Bkgd (Number)	D>Std (Number)						Level	Level
Diethyl Ether	UF	µg/L	40	0	0	n/a	n/a	n/a	n/a	n/a	na	na	na	15	n/a	-	n/a	-
Diethylphthalate	UF	µg/L	59	0	0	n/a	n/a	n/a	n/a	0	na	29200	Reg6	14	n/a	-	0	-
Dimethyl Phthalate	UF	µg/L	59	0	0	n/a	n/a	n/a	n/a	0	na	365000	Reg6	14	n/a	-	0	-
Dimethylphenol[2,4-]	UF	µg/L	52	0	0	n/a	n/a	n/a	n/a	0	na	730	Reg6	14	n/a	-	0	-
Dinitro-2-methylphenol[4,6-]	UF	µg/L	52	0	0	n/a	n/a	n/a	n/a	n/a	na	na	na	14	n/a	-	n/a	-
Dinitrobenzene[1,3-]	UF	µg/L	61	0	0	n/a	n/a	n/a	n/a	0	na	3.65	Reg6	16	n/a	-	0	-
Dinitrophenol[2,4-]	UF	µg/L	52	0	0	n/a	n/a	n/a	n/a	0	na	73	Reg6	14	n/a	-	0	-
Dinitrotoluene[2,4-]	UF	µg/L	61	0	0	n/a	n/a	n/a	n/a	0	na	73	Reg6	16	n/a	-	0	-
Dinitrotoluene[2,6-]	UF	µg/L	61	0	0	n/a	n/a	n/a	n/a	0	na	36.5	Reg6	16	n/a	-	0	-
Dinoseb	UF	µg/L	55	0	0	n/a	n/a	n/a	n/a	0	na	7	MCL	14	n/a	-	0	-
Dioxane[1,4-]	UF	µg/L	56	1	1.79	1190	1190	1190	n/a	1	na	61.12	Reg6	13	n/a	-	1	16
Diphenylamine	UF	µg/L	59	0	0	n/a	n/a	n/a	n/a	0	na	912.5	Reg6	14	n/a	-	0	-
Endosulfan I	UF	µg/L	59	1	1.69	0.0265	0.0265	0.0265	n/a	n/a	na	na	na	14	n/a	-	n/a	-
Endosulfan II	UF	µg/L	59	1	1.69	0.0468	0.0468	0.0468	n/a	n/a	na	na	na	14	n/a	-	n/a	-
Endosulfan Sulfate	UF	µg/L	59	1	1.69	0.0568	0.0568	0.0568	n/a	n/a	na	na	na	14	n/a	-	n/a	-
Endrin	UF	µg/L	59	1	1.69	0.0346	0.0346	0.0346	n/a	0	na	2	MCL	14	n/a	-	0	-
Endrin Aldehyde	UF	µg/L	59	0	0	n/a	n/a	n/a	n/a	n/a	na	na	na	14	n/a	-	n/a	-
Endrin Ketone	UF	µg/L	59	0	0	n/a	n/a	n/a	n/a	n/a	na	na	na	14	n/a	-	n/a	-
Ethyl Methacrylate	UF	µg/L	61	0	0	n/a	n/a	n/a	n/a	0	na	547.5	Reg6	16	n/a	-	0	-
Ethylbenzene	UF	µg/L	61	0	0	n/a	n/a	n/a	n/a	0	na	700	MCL	16	n/a	-	0	-
Fluoranthene	UF	µg/L	59	0	0	n/a	n/a	n/a	n/a	0	na	1460	Reg6	14	n/a	-	0	-
Fluorene	UF	µg/L	59	0	0	n/a	n/a	n/a	n/a	0	na	243.3	Reg6	14	n/a	-	0	-
HMX	UF	µg/L	61	0	0	n/a	n/a	n/a	n/a	0	na	1825	Reg6	16	n/a	-	0	-
Heptachlor	UF	µg/L	59	1	1.69	0.0114	0.0114	0.0114	n/a	0	na	0.4	MCL	14	n/a	-	0	-
Heptachlor Epoxide	UF	µg/L	59	1	1.69	0.0247	0.0247	0.0247	n/a	0	na	0.2	MCL	14	n/a	-	0	-
Hexachlorobenzene	UF	µg/L	59	0	0	n/a	n/a	n/a	n/a	0	na	1	MCL	14	n/a	-	0	-
Hexachlorobutadiene	UF	µg/L	61	0	0	n/a	n/a	n/a	n/a	0	na	8.619	Reg6	16	n/a	-	0	-
Hexachlorocyclopentadiene	UF	µg/L	59	0	0	n/a	n/a	n/a	n/a	0	na	50	MCL	14	n/a	-	0	-
Hexachloroethane	UF	µg/L	59	0	0	n/a	n/a	n/a	n/a	0	na	48.02	Reg6	14	n/a	-	0	-
Hexanone[2-]	UF	µg/L	61	0	0	n/a	n/a	n/a	n/a	n/a	na	na	na	16	n/a	-	n/a	-
Indeno[1,2,3-cd]pyrene	UF	µg/L	59	0	0	n/a	n/a	n/a	n/a	0	na	0.295	Reg6	14	n/a	-	0	-
Iodomethane	UF	µg/L	61	0	0	n/a	n/a	n/a	n/a	n/a	na	na	na	16	n/a	-	n/a	-
Isobutyl alcohol	UF	µg/L	35	0	0	n/a	n/a	n/a	n/a	n/a	na	na	na	9	n/a	-	n/a	-
Isophorone	UF	µg/L	59	0	0	n/a	n/a	n/a	n/a	0	na	707.7	Reg6	14	n/a	-	0	-
Isopropylbenzene	UF	µg/L	61	0	0	n/a	n/a	n/a	n/a	0	na	658.2	Reg6	16	n/a	-	0	-
Isopropyltoluene[4-]	UF	µg/L	61	0	0	n/a	n/a	n/a	n/a	n/a	na	na	na	16	n/a	-	n/a	-
MCPA	UF	µg/L	19	0	0	n/a	n/a	n/a	n/a	0	na	18.25	Reg6	13	n/a	-	0	-

Table 6.3-3 (continued)

Constituent			Summary by Sample								Screening Values			Location Summary				
Organics	Field Prep	Units	Total	Detects (D)			Exceedances		GW Bkgd ^a	Screening Standard ^b		Locations with Data (Number)	D>Bkgd (Number of Locations)	D>Bkgd Station List ^c	D>Std (Number of Locations)	D>Std Station List ^c		
				Number	Rate (%)	Min.	Median	Max.		D>Bkgd (Number)	D>Std (Number)						Level	Level
MCPPP	UF	µg/L	19	0	0	n/a	n/a	n/a	n/a	0	na	36.5	Reg6	13	n/a	-	0	-
MNX	UF	µg/L	58	0	0	n/a	n/a	n/a	n/a	n/a	na	na	na	15	n/a	-	n/a	-
Methacrylonitrile	UF	µg/L	61	0	0	n/a	n/a	n/a	n/a	0	na	1.043	Reg6	16	n/a	-	0	-
Methoxychlor[4,4'-]	UF	µg/L	59	0	0	n/a	n/a	n/a	n/a	0	na	40	MCL	14	n/a	-	0	-
Methyl Methacrylate	UF	µg/L	61	0	0	n/a	n/a	n/a	n/a	0	na	1419.4	Reg6	16	n/a	-	0	-
Methyl tert-Butyl Ether	UF	µg/L	40	0	0	n/a	n/a	n/a	n/a	0	na	370.8	Reg6	15	n/a	-	0	-
Methyl-2-pentanone[4-]	UF	µg/L	61	0	0	n/a	n/a	n/a	n/a	0	na	1990.9	Reg6	16	n/a	-	0	-
Methylene Chloride	UF	µg/L	61	0	0	n/a	n/a	n/a	n/a	0	na	5	MCL	16	n/a	-	0	-
Methylnaphthalene[1-]	UF	µg/L	59	0	0	n/a	n/a	n/a	n/a	n/a	na	na	na	14	n/a	-	n/a	-
Methylnaphthalene[2-]	UF	µg/L	59	0	0	n/a	n/a	n/a	n/a	n/a	na	na	na	14	n/a	-	n/a	-
Methylphenol[2-]	UF	µg/L	52	0	0	n/a	n/a	n/a	n/a	0	na	1825	Reg6	14	n/a	-	0	-
Methylphenol[3-,4-]	UF	µg/L	26	0	0	n/a	n/a	n/a	n/a	n/a	na	na	na	8	n/a	-	n/a	-
Methylphenol[4-]	UF	µg/L	26	0	0	n/a	n/a	n/a	n/a	0	na	182.5	Reg6	13	n/a	-	0	-
Naphthalene	UF	µg/L	61	0	0	n/a	n/a	n/a	n/a	0	na	30	NMGSU	16	n/a	-	0	-
Nitroaniline[2-]	UF	µg/L	59	0	0	n/a	n/a	n/a	n/a	0	na	109.5	Reg6	14	n/a	-	0	-
Nitroaniline[3-]	UF	µg/L	59	0	0	n/a	n/a	n/a	n/a	n/a	na	na	na	14	n/a	-	n/a	-
Nitroaniline[4-]	UF	µg/L	59	0	0	n/a	n/a	n/a	n/a	n/a	na	na	na	14	n/a	-	n/a	-
Nitrobenzene	UF	µg/L	61	0	0	n/a	n/a	n/a	n/a	0	na	3.395	Reg6	16	n/a	-	0	-
Nitrophenol[2-]	UF	µg/L	45	0	0	n/a	n/a	n/a	n/a	n/a	na	na	na	14	n/a	-	n/a	-
Nitrophenol[4-]	UF	µg/L	51	0	0	n/a	n/a	n/a	n/a	0	na	292	Reg6	14	n/a	-	0	-
Nitroso-di-n-butylamine[N-]	UF	µg/L	59	0	0	n/a	n/a	n/a	n/a	0	na	0.1227	Reg6	14	n/a	-	0	-
Nitroso-di-n-propylamine[N-]	UF	µg/L	59	0	0	n/a	n/a	n/a	n/a	0	na	0.09604	Reg6	14	n/a	-	0	-
Nitrosodiethylamine[N-]	UF	µg/L	59	0	0	n/a	n/a	n/a	n/a	0	na	0.001436	Reg6	14	n/a	-	0	-
Nitrosodimethylamine[N-]	UF	µg/L	59	0	0	n/a	n/a	n/a	n/a	0	na	0.00422	Reg6	14	n/a	-	0	-
Nitrosopyrrolidine[N-]	UF	µg/L	59	0	0	n/a	n/a	n/a	n/a	0	na	0.3202	Reg6	14	n/a	-	0	-
Nitrotoluene[2-]	UF	µg/L	61	0	0	n/a	n/a	n/a	n/a	0	na	2.923	Reg6	16	n/a	-	0	-
Nitrotoluene[3-]	UF	µg/L	61	0	0	n/a	n/a	n/a	n/a	0	na	121.7	Reg6	16	n/a	-	0	-
Nitrotoluene[4-]	UF	µg/L	61	0	0	n/a	n/a	n/a	n/a	0	na	39.55	Reg6	16	n/a	-	0	-
Oxybis[1-chloropropane][2,2'-]	UF	µg/L	58	0	0	n/a	n/a	n/a	n/a	0	na	9.536	Reg6	14	n/a	-	0	-
PETN	UF	µg/L	61	0	0	n/a	n/a	n/a	n/a	n/a	na	na	na	16	n/a	-	n/a	-
Pentachlorobenzene	UF	µg/L	59	0	0	n/a	n/a	n/a	n/a	0	na	29.2	Reg6	14	n/a	-	0	-
Pentachlorophenol	UF	µg/L	50	0	0	n/a	n/a	n/a	n/a	0	na	1	MCL	14	n/a	-	0	-
Phenanthrene	UF	µg/L	57	0	0	n/a	n/a	n/a	n/a	n/a	na	na	na	14	n/a	-	n/a	-
Phenol	UF	µg/L	52	0	0	n/a	n/a	n/a	n/a	0	na	5	NMGSU	14	n/a	-	0	-
Propionitrile	UF	µg/L	50	0	0	n/a	n/a	n/a	n/a	n/a	na	na	na	15	n/a	-	n/a	-
Propylbenzene[1-]	UF	µg/L	61	0	0	n/a	n/a	n/a	n/a	0	na	60.83	Reg6	16	n/a	-	0	-
Pyrene	UF	µg/L	59	0	0	n/a	n/a	n/a	n/a	0	na	182.5	Reg6	14	n/a	-	0	-

Table 6.3-3 (continued)

Constituent			Summary by Sample								Screening Values			Location Summary				
Organics	Field Prep	Units	Total	Detects (D)			Exceedances		GW Bkgd ^a	Screening Standard ^b		Locations with Data (Number)	D>Bkgd (Number of Locations)	D>Bkgd Station List ^c	D>Std (Number of Locations)	D>Std Station List ^c		
				Number	Rate (%)	Min.	Median	Max.		D>Bkgd (Number)	D>Std (Number)						Level	Level
Pyridine	UF	µg/L	39	0	0	n/a	n/a	n/a	n/a	0	na	36.5	Reg6	13	n/a	-	0	-
RDX	UF	µg/L	61	0	0	n/a	n/a	n/a	n/a	0	na	6.112	Reg6	16	n/a	-	0	-
Styrene	UF	µg/L	61	0	0	n/a	n/a	n/a	n/a	0	na	100	MCL	16	n/a	-	0	-
TATB	UF	µg/L	61	0	0	n/a	n/a	n/a	n/a	n/a	na	na	na	16	n/a	-	n/a	-
TNX	UF	µg/L	58	0	0	n/a	n/a	n/a	n/a	n/a	na	na	na	15	n/a	-	n/a	-
TP[2,4,5-]	UF	µg/L	19	0	0	n/a	n/a	n/a	n/a	0	na	50	MCL	13	n/a	-	0	-
T[2,4,5-]	UF	µg/L	19	0	0	n/a	n/a	n/a	n/a	0	na	365	Reg6	13	n/a	-	0	-
Tetrachlorobenzene[1,2,4,5]	UF	µg/L	59	0	0	n/a	n/a	n/a	n/a	n/a	na	na	na	14	n/a	-	n/a	-
Tetrachloroethane[1,1,1,2-]	UF	µg/L	61	0	0	n/a	n/a	n/a	n/a	0	na	25.5	Reg6	16	n/a	-	0	-
Tetrachloroethane[1,1,2,2-]	UF	µg/L	61	0	0	n/a	n/a	n/a	n/a	0	na	10	NMGSU	16	n/a	-	0	-
Tetrachloroethene	UF	µg/L	56	0	0	n/a	n/a	n/a	n/a	0	na	5	MCL	16	n/a	-	0	-
Tetrachlorophenol[2,3,4,6-]	UF	µg/L	52	0	0	n/a	n/a	n/a	n/a	0	na	5	MCL	14	n/a	-	0	-
Tetryl	UF	µg/L	59	0	0	n/a	n/a	n/a	n/a	0	na	146	Reg6	15	n/a	-	0	-
Toluene	UF	µg/L	61	0	0	n/a	n/a	n/a	n/a	0	na	750	NMGSU	16	n/a	-	0	-
Toxaphene [Technical Grade]	UF	µg/L	59	0	0	n/a	n/a	n/a	n/a	0	na	3	MCL	14	n/a	-	0	-
Trichloro-1,2,2-trifluoroethane[1,1,2-]	UF	µg/L	61	0	0	n/a	n/a	n/a	n/a	0	na	59180	Reg6	16	n/a	-	0	-
Trichlorobenzene[1,2,3-]	UF	µg/L	61	0	0	n/a	n/a	n/a	n/a	n/a	na	na	na	16	n/a	-	n/a	-
Trichlorobenzene[1,2,4-]	UF	µg/L	61	0	0	n/a	n/a	n/a	n/a	0	na	70	MCL	16	n/a	-	0	-
Trichloroethane[1,1,1-]	UF	µg/L	61	0	0	n/a	n/a	n/a	n/a	0	na	60	NMGSU	16	n/a	-	0	-
Trichloroethane[1,1,2-]	UF	µg/L	61	0	0	n/a	n/a	n/a	n/a	0	na	5	MCL	16	n/a	-	0	-
Trichloroethene	UF	µg/L	61	0	0	n/a	n/a	n/a	n/a	0	na	5	MCL	16	n/a	-	0	-
Trichlorofluoromethane	UF	µg/L	60	0	0	n/a	n/a	n/a	n/a	0	na	5	MCL	16	n/a	-	0	-
Trichlorophenol[2,4,5-]	UF	µg/L	49	0	0	n/a	n/a	n/a	n/a	0	na	3650	Reg6	14	n/a	-	0	-
Trichlorophenol[2,4,6-]	UF	µg/L	49	0	0	n/a	n/a	n/a	n/a	0	na	61.12	Reg6	14	n/a	-	0	-
Trichloropropane[1,2,3-]	UF	µg/L	61	0	0	n/a	n/a	n/a	n/a	0	na	0.0947	Reg6	16	n/a	-	0	-
Trimethylbenzene[1,2,4-]	UF	µg/L	61	0	0	n/a	n/a	n/a	n/a	0	na	12.43	Reg6	16	n/a	-	0	-
Trimethylbenzene[1,3,5-]	UF	µg/L	61	0	0	n/a	n/a	n/a	n/a	0	na	12.33	Reg6	16	n/a	-	0	-
Trinitrobenzene[1,3,5-]	UF	µg/L	61	0	0	n/a	n/a	n/a	n/a	0	na	1095	Reg6	16	n/a	-	0	-
Trinitrotoluene[2,4,6-]	UF	µg/L	61	0	0	n/a	n/a	n/a	n/a	0	na	22.41	Reg6	16	n/a	-	0	-

Table 6.3-3 (continued)

Constituent			Summary by Sample								Screening Values			Location Summary				
Organics	Field Prep	Units	Total	Detects (D)			Exceedances		GW Bkgd ^a	Screening Standard ^b		Locations with Data (Number)	D>Bkgd (Number of Locations)	D>Bkgd Station List ^c	D>Std (Number of Locations)	D>Std Station List ^c		
				Number	Rate (%)	Min.	Median	Max.		D>Bkgd (Number)	D>Std (Number)						Level	Level
Tris [o-cresyl] phosphate	UF	µg/L	44	0	0	n/a	n/a	n/a	n/a	n/a	na	na	na	15	n/a	-	n/a	-
Vinyl Chloride	UF	µg/L	61	0	0	n/a	n/a	n/a	0	0	na	1	NMGSU	16	n/a	-	0	-
Vinyl acetate	UF	µg/L	61	0	0	n/a	n/a	n/a	0	0	na	412.4	Reg6	16	n/a	-	0	-
Xylene[1,2-]	UF	µg/L	61	0	0	n/a	n/a	n/a	0	0	na	1431.4	Reg6	16	n/a	-	0	-
Xylene[1,3-]+Xylene[1,4-]	UF	µg/L	61	0	0	n/a	n/a	n/a	n/a	n/a	na	na	na	16	n/a	-	n/a	-

Notes: Light grey indicates exceeds groundwater background. Dark grey indicates exceeds standard.

^a Groundwater background UTL or maximum detect for alluvial groundwater filtered samples; LANL "Groundwater Background Investigation Report, Revision 3" (2007, 095817).

^c Station List (codes)

- 1 = 18-BG-1 9 = PCAO-7a
- 2 = 18-BG-4 10 = PCAO-7b2
- 3 = 18-MW-11 11 = PCAO-7c
- 4 = 18-MW-18 12 = PCAO-8
- 5 = 18-MW-8 13 = PCAO-9
- 6 = 18-MW-9 14 = PCO-1
- 7 = 3MAO-2 15 = PCO-2
- 8 = PCAO-5 16 = PCO-3

^b Screening Standard

- Std Type Standard (Source and Name)
- NMGSF NMAC 20.6.2, Groundwater Standards (Filtered)
- NMGSU NMAC 20.6.2, Groundwater Standards (Unfiltered)
- NMRPS NMEIB Radiation Protection Standards
- MCL EPA MCL
- SMCL EPA SMCL
- Reg6 EPA Region 6 Tap Water Screening Level
- DCG DOE 4-mrem DCG

^d n/a = Not applicable.

^e na = Not available (no published value).

^f - = None.

Table 6.3-4
Screening Table for Pajarito Watershed General Inorganics in Alluvial Groundwater

Constituent			Summary by Sample								Screening Values			Location Summary				
General Inorganics	Field Prep	Units	Total	Detects (D)			Exceedances		GW Bkgd ^a	Screening Standard ^b		Locations with Data (Number)	D>Bkgd (Number of Locations)	D>Bkgd Station List ^c	D>Std (Number of Locations)	D>Std Station List ^c		
				Number	Rate (%)	Min.	Median	Max.		D>Bkgd (Number)	D>Std (Number)						Level	Level
Alkalinity-CO ³	F	µg/L	60	0	0	n/a ^d	n/a	n/a	n/a	n/a	na ^e	na	na	14	n/a	- ^f	n/a	-
Alkalinity-CO ³ +HCO ³	F	µg/L	60	60	100	35800	56250	303000	n/a	n/a	na	na	na	14	n/a	-	n/a	-
Ammonia as Nitrogen	F	µg/L	54	2	3.7	37	484.5	932	n/a	1	na	208.57	Reg6	14	n/a	-	1	8
Bromide	F	µg/L	60	10	16.7	73	191.5	335	9	n/a	100	na	na	14	5	3, 8, 14, 15, 16	n/a	-
Calcium	F	µg/L	61	61	100	12100	17100	128000	20	n/a	26360	na	na	15	6	4, 8, 12, 13, 15, 16	n/a	-
Chloride	F	µg/L	60	60	100	14200	26200	320000	16	2	69760	250000	NMGSF	14	4	4, 12, 15, 16	1	16
Cyanide [Total]	F	µg/L	14	0	0	n/a	n/a	n/a	n/a	n/a	NA	NA	NA	8	n/a	-	n/a	-
Fluoride	F	µg/L	60	60	100	95	157.5	545	7	0	270	1600	NMGSF	14	2	8, 16	0	-
Hardness	F	µg/L	61	61	100	46800	62800	446000	n/a	n/a	na	na	na	15	n/a	-	n/a	-
Magnesium	F	µg/L	61	61	100	3870	5150	30400	19	n/a	7780	na	na	15	6	4, 8, 12, 13, 15, 16	n/a	-
Nitrate-Nitrite as Nitrogen	F	µg/L	58	52	89.7	24	557.5	5720	26	0	570	10000	NMGSF	14	5	3, 4, 5, 6, 9	0	-
Perchlorate	F	µg/L	59	46	78	0.0612	0.2765	0.568	0	0	14.2	24.5	Reg6	14	0	-	0	-
Potassium	F	µg/L	61	61	100	1930	3670	7620	11	n/a	5210	na	na	15	4	4, 8, 12, 15	n/a	-
Silicon Dioxide	F	µg/L	61	61	100	23500	33600	45200	0	n/a	64210	na	na	15	0	-	n/a	-
Sodium	F	µg/L	61	61	100	14800	18800	139000	54	n/a	15540	na	na	15	15	1, 3, 4, 5, 6, 7, 8, 9, 10, 11, 12, 13, 14, 15, 16	n/a	-
Specific Conductance	F	µS/cm	60	60	100	179	237.5	1420	n/a	n/a	na	na	na	14	n/a	-	n/a	-
Sulfate	F	µg/L	60	60	100	4660	13300	90400	6	0	24830	600000	NMGSF	14	1	16	0	-
Total Dissolved Solids	F	µg/L	60	60	100	102000	169500	859000	51	0	139000	1000000	NMGSF	14	13	1, 3, 4, 5, 6, 8, 9, 10, 11, 12, 14, 15, 16	0	-
Total Kjeldahl Nitrogen	F	µg/L	32	19	59.4	34	147	938	4	n/a	460	na	na	8	2	3, 16	n/a	-
Total Phosphate as Phosphorus	F	µg/L	60	20	33.3	12	59	228	15	n/a	40	na	na	15	9	1, 3, 5, 6, 9, 11, 14, 15, 16	n/a	-
pH	F	SU	60	60	100	6.24	6.83	7.94	n/a	0	na	9	NMGSF	14	n/a	-	0	-
Alkalinity-CO ³	UF	µg/L	11	0	0	n/a	n/a	n/a	n/a	n/a	na	na	na	6	n/a	-	n/a	-
Alkalinity-CO ³ +HCO ³	UF	µg/L	11	11	100	43300	57100	216000	n/a	n/a	na	na	na	6	n/a	-	n/a	-
Ammonia as Nitrogen	UF	µg/L	10	1	10	20	20	20	n/a	0	na	208.57	Reg6	6	n/a	-	0	-
Bromide	UF	µg/L	11	1	9.09	348	348	348	n/a	n/a	na	na	na	6	n/a	-	n/a	-
Calcium	UF	µg/L	60	60	100	12000	16850	129000	n/a	n/a	na	na	na	15	n/a	-	n/a	-
Chemical Oxygen Demand	UF	µg/L	5	3	60	10100	10800	11500	n/a	n/a	na	na	na	5	n/a	-	n/a	-
Chloride	UF	µg/L	11	11	100	14600	16900	288000	n/a	n/a	na	na	na	6	n/a	-	n/a	-
Cyanide [Total]	UF	µg/L	53	5	9.43	1.81	2.98	54.6	n/a	n/a	na	na	na	7	n/a	-	n/a	-
Fluoride	UF	µg/L	11	11	100	101	133	296	n/a	0	na	4000	MCL	6	n/a	-	0	-
Hardness	UF	µg/L	60	60	100	47100	64050	446000	n/a	n/a	na	na	na	15	n/a	-	n/a	-
Magnesium	UF	µg/L	60	60	100	3890	5340	30000	n/a	n/a	na	na	na	15	n/a	-	n/a	-
Nitrate-Nitrite as Nitrogen	UF	µg/L	11	11	100	36.8	1270	6000	n/a	0	na	10000	MCL	6	n/a	-	0	-

Table 6.3-4 (continued)

Constituent			Summary by Sample								Screening Values			Location Summary				
General Inorganics	Field Prep	Units	Total	Detects (D)			Exceedances		GW Bkgd ^a	Screening Standard ^b		Locations with Data (Number)	D>Bkgd (Number of Locations)	D>Bkgd Station List ^c	D>Std (Number of Locations)	D>Std Station List ^c		
				Number	Rate (%)	Min.	Median	Max.		D>Bkgd (Number)	D>Std (Number)						Level	Level
Potassium	UF	µg/L	60	60	100	1960	3765	7800	n/a	n/a	na	na	na	15	n/a	-	n/a	-
Silicon Dioxide	UF	µg/L	14	14	100	31600	38150	49100	n/a	n/a	na	na	na	8	n/a	-	n/a	-
Sodium	UF	µg/L	60	60	100	14600	19200	866000	n/a	n/a	na	na	na	15	n/a	-	n/a	-
Specific Conductance	UF	µS/cm	11	11	100	168	210	1430	10	n/a	184.2	na	na	6	6	1, 3, 4, 5, 6, 16	n/a	-
Sulfate	UF	µg/L	11	11	100	11300	13300	88100	n/a	n/a	na	na	na	6	n/a	-	n/a	-
Suspended Sediment Concentration	UF	µg/L	3	2	66.7	3600	4600	5600	n/a	n/a	na	na	na	3	n/a	-	n/a	-
Total Kjeldahl Nitrogen	UF	µg/L	57	25	43.9	44	124	997	n/a	n/a	na	na	na	14	n/a	-	n/a	-
Total Organic Carbon	UF	µg/L	57	56	98.2	1320	2505	19400	n/a	n/a	na	na	na	14	n/a	-	n/a	-
Total Phosphate as Phosphorus	UF	µg/L	11	4	36.4	19	34.5	96	n/a	n/a	na	na	na	6	n/a	-	n/a	-
Total Suspended Solids	UF	µg/L	5	5	100	2250	7430	69500	n/a	n/a	na	na	na	5	n/a	-	n/a	-
pH	UF	SU	11	11	100	6.44	6.65	7.16	n/a	n/a	na	na	na	6	n/a	-	n/a	-

Notes: Light grey indicates exceeds groundwater background. Dark grey indicates exceeds standard.

^a Groundwater background UTL or maximum detect for alluvial groundwater filtered samples; LANL "Groundwater Background Investigation Report, Revision 3" (2007, 095817).

^c Station List (codes)

- 1 = 18-BG-1 9 = PCAO-7a
- 2 = 18-BG-4 10 = PCAO-7b2
- 3 = 18-MW-11 11 = PCAO-7c
- 4 = 18-MW-18 12 = PCAO-8
- 5 = 18-MW-8 13 = PCAO-9
- 6 = 18-MW-9 14 = PCO-1
- 7 = 3MAO-2 15 = PCO-2
- 8 = PCAO-5 16 = PCO-3

^b Screening Standard

- Std Type Standard (Source and Name)
- NMGSF NMAC 20.6.2, Groundwater Standards (Filtered)
- NMGSU NMAC 20.6.2, Groundwater Standards (Unfiltered)
- NMRPS NMEIB Radiation Protection Standards
- MCL EPA MCL
- SMCL EPA SMCL
- Reg6 EPA Region 6 Tap Water Screening Level
- DCG DOE 4-mrem DCG

^d n/a = Not applicable.

^e na = Not available (no published value).

^f - = None.

**Table 6.3-5
Screening Table for Pajarito Watershed Metals in Intermediate Perched Groundwater**

Constituent			Summary by Sample								Screening Values			Location Summary				
Metals	Field Prep	Units	Total	Detects (D)					Exceedances		GW Bkgd ^a Level	Screening Standard ^b		Locations with Data (Number)	D>Bkgd (Number of Locations)	D>Bkgd Station List ^c	D>Std (Number of Locations)	D>Std Station List ^c
				Number	Rate (%)	Min.	Median	Max.	D>Bkgd (Number)	D>Std (Number)		Level	Std Type					
Aluminum	F	µg/L	33	20	60.6	81.1	1505	35600	11	3	1065.84	5000	NMGSF	7	2	1, 2	2	1, 2
Antimony	F	µg/L	33	1	3.03	0.61	0.61	0.61	1	0	0.5	6	MCL	7	1	2	0	- ^d
Arsenic	F	µg/L	33	11	33.3	1.6	2	4	0	0	4.32	10	MCL	7	0	-	0	-
Barium	F	µg/L	33	33	100	7.1	57.3	416	13	0	71.83	1000	NMGSF	7	3	1, 2, 3	0	-
Beryllium	F	µg/L	33	2	6.06	1.4	1.6	1.8	2	0	0.5	4	MCL	7	2	1, 2	0	-
Boron	F	µg/L	33	30	90.9	12.7	26.6	50.4	28	0	15.12	750	NMGSF	7	6	1, 2, 3, 5, 6, 7	0	-
Cadmium	F	µg/L	33	2	6.06	0.5	0.505	0.51	2	0	0.5	5	MCL	7	1	2	0	-
Chromium	F	µg/L	33	15	45.5	1.2	2.1	14.8	7	0	2.4	50	NMGSF	7	3	1, 2, 6	0	-
Chromium hexavalent ion	F	µg/L	2	2	100	0.3	0.5	0.7	n/a	0	na	50	NMGSF	2	n/a	-	0	-
Cobalt	F	µg/L	33	8	24.2	1.1	2.15	6.9	7	0	1.2	50	NMGSF	7	3	1, 2, 3	0	-
Copper	F	µg/L	28	14	50	3.1	4.6	14.5	3	0	5.32	1000	NMGSF	5	2	1, 2	0	-
Iron	F	µg/L	33	27	81.8	26	334	21300	8	7	839.99	1000	NMGSF	7	2	1, 2	2	1, 2
Lead	F	µg/L	33	15	45.5	0.56	2.3	20	15	2	0.3	15	MCL	7	2	1, 2	2	1, 2
Manganese	F	µg/L	33	28	84.8	2.7	16	1450	25	3	3.63	200	NMGSF	7	6	1, 2, 3, 5, 6, 7	3	1, 2, 3
Mercury	F	µg/L	32	8	25	0.059	0.16	1.7	8	0	0.03	2	MCL	7	2	1, 2	0	-
Molybdenum	F	µg/L	33	14	42.4	0.45	2.55	6.5	1	0	4.3	1000	NMGSF	7	1	2	0	-
Nickel	F	µg/L	33	31	93.9	0.73	2.4	14.5	0	0	29	100	MCL	7	0	-	0	-
Selenium	F	µg/L	33	0	0	n/a	n/a	n/a	0	0	1.25	50	NMGSF	7	0	-	0	-
Silver	F	µg/L	33	0	0	n/a	n/a	n/a	0	0	0.5	50	NMGSF	7	0	-	0	-
Strontium	F	µg/L	33	33	100	41.1	94.6	604	9	0	154.76	21900	Reg6	7	3	1, 2, 3	0	-
Thallium	F	µg/L	33	7	21.2	0.49	0.58	0.69	6	0	0.5	2	MCL	7	3	1, 2, 6	0	-
Tin	F	µg/L	33	1	3.03	2.9	2.9	2.9	1	0	1.25	21900	Reg6	7	1	2	0	-
Uranium	F	µg/L	33	30	90.9	0.057	0.415	2.5	12	0	0.72	30	NMGSF	7	6	1, 2, 3, 5, 6, 7	0	-
Vanadium	F	µg/L	33	22	66.7	1.2	4.15	25.3	5	0	4.91	182.5	Reg6	7	4	1, 2, 5, 7	0	-
Zinc	F	µg/L	33	25	75.8	2.6	10.4	287	6	0	19	10000	NMGSF	7	4	1, 2, 3, 6	0	-
Aluminum	UF	µg/L	34	22	64.7	400	4155	40600	n/a	1	na	36500	Reg6	7	n/a	-	1	2
Antimony	UF	µg/L	35	0	0	n/a ^e	n/a	n/a	n/a	0	na	6	MCL	7	n/a	-	0	-
Arsenic	UF	µg/L	35	13	37.1	1.5	2	4.9	n/a	0	na	10	MCL	7	n/a	-	0	-
Barium	UF	µg/L	35	35	100	7.9	64.3	434	n/a	0	na	2000	MCL	7	n/a	-	0	-
Beryllium	UF	µg/L	35	4	11.4	1.3	1.65	2.1	n/a	0	na	4	MCL	7	n/a	-	0	-
Boron	UF	µg/L	35	32	91.4	12.8	26.9	63.9	n/a	0	na	7300	Reg6	7	n/a	-	0	-
Cadmium	UF	µg/L	35	7	20	0.17	0.36	1.2	n/a	0	na	5	MCL	7	n/a	-	0	-
Chromium	UF	µg/L	35	18	51.4	1.1	4.16	82.4	n/a	0	na	100	MCL	7	n/a	-	0	-
Cobalt	UF	µg/L	35	3	8.57	2.2	2.3	3.2	n/a	0	na	730	Reg6	7	n/a	-	0	-
Copper	UF	µg/L	32	18	56.3	3.1	6.7	25	n/a	0	na	1300	MCL	6	n/a	-	0	-
Iron	UF	µg/L	35	31	88.6	25.5	1160	25700	n/a	1	na	25550	Reg6	7	n/a	-	1	2

Table 6.3-5 (continued)

Constituent			Summary by Sample							Screening Values			Location Summary					
Metals	Field Prep	Units	Total	Detects (D)			Exceedances		GW Bkgd ^a	Screening Standard ^b		Locations with Data (Number)	D>Bkgd (Number of Locations)	D>Bkgd Station List ^c	D>Std (Number of Locations)	D>Std Station List ^c		
				Number	Rate (%)	Min.	Median	Max.		D>Bkgd (Number)	D>Std (Number)						Level	Level
Lead	UF	µg/L	35	21	60	0.57	3.6	23.5	n/a ^e	3	na ^f	15	Reg6	7	n/a	-	3	1, 2, 7
Manganese	UF	µg/L	35	28	80	3.7	20.35	6170	n/a	1	na	1703.09	Reg6	7	n/a	-	1	3
Mercury	UF	µg/L	34	10	29.4	0.034	0.14	0.97	9	0	0.04	2	NMGSU	7	3	1, 2, 7	0	-
Molybdenum	UF	µg/L	35	14	40	0.46	2.2	7.1	n/a	0	na	182.5	Reg6	7	n/a	-	0	-
Nickel	UF	µg/L	35	33	94.3	0.75	2.7	36.3	n/a	0	na	100	MCL	7	n/a	-	0	-
Selenium	UF	µg/L	35	1	2.86	2.8	2.8	2.8	0	0	8.5	50	MCL	7	0	-	0	-
Silver	UF	µg/L	35	0	0	n/a	n/a	n/a	0	0	0.5	182.5	Reg6	7	0	-	0	-
Strontium	UF	µg/L	35	35	100	44.2	95.4	522	n/a	0	na	21900	Reg6	7	n/a	-	0	-
Thallium	UF	µg/L	35	6	17.1	0.294	0.445	0.69	n/a	0	na	2	MCL	7	n/a	-	0	-
Tin	UF	µg/L	35	1	2.86	2.7	2.7	2.7	n/a	0	na	21900	Reg6	7	n/a	-	0	-
Uranium	UF	µg/L	35	33	94.3	0.11	0.59	4.6	n/a	0	na	30	MCL	7	n/a	-	0	-
Vanadium	UF	µg/L	35	26	74.3	1.5	4.55	29.2	n/a	0	na	182.5	Reg6	7	n/a	-	0	-
Zinc	UF	µg/L	34	29	85.3	2.6	17.4	284	n/a	0	na	10950	Reg6	7	n/a	-	0	-

Notes: Light grey indicates exceeds groundwater background. Dark grey indicates exceeds standard.

^a Groundwater background UTL or maximum detect for intermediate groundwater filtered samples.

^c Station List (codes)

- 1 = 03-B-10 4 = R-19, screen 2
- 2 = 03-B-13 5 = R-23i, screen 1
- 3 = 03-B-9 6 = R-23i, screen 2
- 7 = R-23i, screen 3

^b Screening Standard

- Std Type Standard (Source and Name)
- NMGSF NMAC 20.6.2, Groundwater Standards (Filtered)
- NMGSU NMAC 20.6.2, Groundwater Standards (Unfiltered)
- NMRPS NMEIB Radiation Protection Standards
- MCL EPA MCL
- SMCL EPA SMCL
- Reg6 EPA Region 6 Tap Water Screening Level
- DCG DOE 4-mrem DCG

^d - = None.

^e n/a = Not applicable.

^f na = Not available (no published value).

**Table 6.3-6
Screening Table for Pajarito Watershed Radionuclides in Intermediate Perched Groundwater**

Constituent			Summary by Sample								Screening Values			Location Summary				
Radionuclides	Field Prep	Units	Total	Detects (D)			Std Type		D>Bkgd (Number)	D>Std (Number)	GW Bkgd ^a	Screening Standard ^b		Locations with Data (Number)	D>Bkgd (Number of Locations)	D>Bkgd Station List ^c	D>Std (Number of Locations)	D>Std Station List ^c
				Number	Rate (%)	Min.	Median	Max.				Level	Level					
Americium-241	F	pCi/L	31	1	3.23	0.0554	0.0554	0.0554	0	0	0.11	20	NMRPS	7	0	- ^d	0	-
Cesium-137	F	pCi/L	30	1	3.33	3.11	3.11	3.11	1	0	0.76	1000	NMRPS	7	1	1	0	-
Cobalt-60	F	pCi/L	28	0	0	n/a ^e	n/a	n/a	n/a	0	na ^f	3000	NMRPS	7	n/a	-	0	-
Gross alpha	F	pCi/L	22	4	18.2	2.3	4.11	6.79	n/a	0	na	15	MCL	7	n/a	-	0	-
Gross beta	F	pCi/L	22	15	68.2	3.27	6.37	11.6	n/a	0	na	50	SMCL	7	n/a	-	0	-
Gross gamma	F	pCi/L	31	0	0	n/a	n/a	n/a	n/a	n/a	na	na	na	7	n/a	-	n/a	-
Iodine-129	F	pCi/L	2	0	0	n/a	n/a	n/a	n/a	n/a	na	na	na	2	n/a	-	n/a	-
Neptunium-237	F	pCi/L	31	0	0	n/a	n/a	n/a	n/a	0	na	20	NMRPS	7	n/a	-	0	-
Plutonium-238	F	pCi/L	31	0	0	n/a	n/a	n/a	0	0	0.01	20	NMRPS	7	0	-	0	-
Plutonium-239/240	F	pCi/L	29	0	0	n/a	n/a	n/a	n/a	0	na	20	NMRPS	7	n/a	-	0	-
Potassium-40	F	pCi/L	30	0	0	n/a	n/a	n/a	n/a	0	na	4000	NMRPS	7	n/a	-	0	-
Sodium-22	F	pCi/L	31	0	0	n/a	n/a	n/a	n/a	0	na	6000	NMRPS	7	n/a	-	0	-
Strontium-90	F	pCi/L	31	9	29	0.456	0.889	2.31	9	0	0.05	8	MCL	7	2	1, 2	0	-
Technetium-99	F	pCi/L	2	0	0	n/a	n/a	n/a	n/a	0	na	4000	DCG	2	n/a	-	0	-
Uranium-234	F	pCi/L	31	24	77.4	0.0618	0.42	1.09	15	0	0.26	300	NMRPS	7	6	1, 2, 4, 5, 6, 7	0	-
Uranium-235/236	F	pCi/L	31	4	12.9	0.0436	0.05395	0.092	n/a	0	na	300	NMRPS	7	n/a	-	0	-
Uranium-238	F	pCi/L	31	26	83.9	0.0406	0.1935	0.632	12	0	0.2	300	NMRPS	7	5	1, 2, 5, 6, 7	0	-
Americium-241	UF	pCi/L	33	1	3.03	0.0458	0.0458	0.0458	n/a	0	na	20	NMRPS	7	n/a	-	0	-
Cesium-137	UF	pCi/L	31	0	0	n/a	n/a	n/a	n/a	0	na	1000	NMRPS	7	n/a	-	0	-
Cobalt-60	UF	pCi/L	33	0	0	n/a	n/a	n/a	n/a	0	na	3000	NMRPS	7	n/a	-	0	-
Gross alpha	UF	pCi/L	24	14	58.3	2.06	4.82	17	n/a	1	na	15	MCL	7	n/a	-	1	7
Gross beta	UF	pCi/L	24	14	58.3	3.6	9.795	24.8	n/a	0	na	50	SMCL	7	n/a	-	0	-
Gross gamma	UF	pCi/L	33	0	0	n/a	n/a	n/a	n/a	n/a	na	na	na	7	n/a	-	n/a	-
Iodine-129	UF	pCi/L	2	0	0	n/a	n/a	n/a	n/a	n/a	na	na	na	2	n/a	-	n/a	-
Neptunium-237	UF	pCi/L	32	0	0	n/a	n/a	n/a	n/a	0	na	20	NMRPS	7	n/a	-	0	-
Plutonium-238	UF	pCi/L	32	1	3.13	0.0396	0.0396	0.0396	n/a	0	na	20	NMRPS	7	n/a	-	0	-
Plutonium-239/240	UF	pCi/L	32	1	3.13	0.0253	0.0253	0.0253	n/a	0	na	20	NMRPS	7	n/a	-	0	-
Potassium-40	UF	pCi/L	26	2	7.69	73.6	73.95	74.3	n/a	0	na	4000	NMRPS	7	n/a	-	0	-
Radium-226	UF	pCi/L	9	4	44.4	0.384	0.8885	0.937	n/a	0	na	5	MCL	5	n/a	-	0	-
Radium-228	UF	pCi/L	8	3	37.5	1.15	1.21	1.46	n/a	0	na	5	MCL	5	n/a	-	0	-
Sodium-22	UF	pCi/L	33	0	0	n/a	n/a	n/a	n/a	0	na	6000	NMRPS	7	n/a	-	0	-
Strontium-90	UF	pCi/L	33	10	30.3	0.354	1.095	1.88	n/a	0	na	8	MCL	7	n/a	-	0	-
Technetium-99	UF	pCi/L	2	0	0	n/a	n/a	n/a	n/a	0	na	4000	DCG	2	n/a	-	0	-
Thorium-228	UF	pCi/L	1	0	0	n/a	n/a	n/a	n/a	n/a	na	na	na	1	n/a	-	n/a	-
Thorium-230	UF	pCi/L	1	0	0	n/a	n/a	n/a	n/a	n/a	na	na	na	1	n/a	-	n/a	-

Table 6.3-6 (continued)

Constituent			Summary by Sample								Screening Values			Location Summary				
Radionuclides	Field Prep	Units	Total	Detects (D)			Std Type		GW Bkgd ^a	Screening Standard ^b		Locations with Data (Number)	D>Bkgd (Number of Locations)	D>Bkgd Station List ^c	D>Std (Number of Locations)	D>Std Station List ^c		
				Number	Rate (%)	Min.	Median	Max.		D>Bkgd (Number)	D>Std (Number)						Level	Level
Thorium-232	UF	pCi/L	1	0	0	n/a	n/a	n/a	n/a	n/a	na	na	na	1	n/a	-	n/a	-
Tritium	UF	pCi/L	44	31	70.5	21.07	217	2040	31	0	7.54	20000	MCL	7	6	1, 2, 3, 5, 6, 7	0	-
Uranium-234	UF	pCi/L	33	29	87.9	0.0947	0.348	1.79	n/a	0	na	300	NMRPS	7	n/a	-	0	-
Uranium-235/236	UF	pCi/L	33	5	15.2	0.0361	0.0505	0.0837	n/a	0	na	300	NMRPS	7	n/a	-	0	-
Uranium-238	UF	pCi/L	33	30	90.9	0.0607	0.232	1.78	n/a	0	na	300	NMRPS	7	n/a	-	0	-

Notes: Light grey indicates exceeds groundwater background. Dark grey indicates exceeds standard.

^aGroundwater background UTL or maximum detect for intermediate groundwater filtered samples.

^cStation List (codes)

- 1 = 03-B-10 4 = R-19, screen 2
- 2 = 03-B-13 5 = R-23i, screen 1
- 3 = 03-B-9 6 = R-23i, screen 2
- 7 = R-23i, screen 3

^bScreening Standard

- Std Type Standard (Source and Name)
- NMGSF NMAC 20.6.2, Groundwater Standards (Filtered)
- NMGSU NMAC 20.6.2, Groundwater Standards (Unfiltered)
- NMRPS NMEIB Radiation Protection Standards
- MCL EPA MCL
- SMCL EPA SMCL
- Reg6 EPA Region 6 Tap Water Screening Level
- DCG DOE 4-mrem DCG

^d - = None.

^e n/a = Not applicable.

^f na = Not available (no published value).

**Table 6.3-7
Screening Table for Pajarito Watershed Organics in Intermediate Perched Groundwater**

Constituent			Summary by Sample								Screening Values			Location Summary				
Organics	Field Prep	Units	Total	Detects (D)			Exceedances		GW Bkgd ^a	Screening Standard ^b		Locations with Data (Number)	D>Bkgd (Number of Locations)	D>Bkgd Station List ^c	D>Std (Number of Locations)	D>Std Station List ^c		
				Number	Rate (%)	Min.	Median	Max.		D>Bkgd (Number)	D>Std (Number)						Level	Level
2,4-Diamino-6-nitrotoluene	UF	µg/L	31	0	0	n/a ^d	n/a	n/a	n/a	n/a	na ^e	na	na	7	n/a	- ^f	n/a	-
2,6-Diamino-4-nitrotoluene	UF	µg/L	31	0	0	n/a	n/a	n/a	n/a	n/a	na	na	na	7	n/a	-	n/a	-
3,5-Dinitroaniline	UF	µg/L	31	0	0	n/a	n/a	n/a	n/a	n/a	na	na	na	7	n/a	-	n/a	-
Acenaphthene	UF	µg/L	30	0	0	n/a	n/a	n/a	n/a	0	na	365	Reg6	6	n/a	-	0	-
Acenaphthylene	UF	µg/L	30	0	0	n/a	n/a	n/a	n/a	n/a	na	na	na	6	n/a	-	n/a	-
Acetone	UF	µg/L	31	8	25.8	1.33	4.44	22.7	n/a	0	na	5475	Reg6	6	n/a	-	0	-
Acetonitrile	UF	µg/L	29	0	0	n/a	n/a	n/a	n/a	0	na	124.1	Reg6	6	n/a	-	0	-
Acrolein	UF	µg/L	31	0	0	n/a	n/a	n/a	n/a	0	na	0.0416	Reg6	6	n/a	-	0	-
Acrylonitrile	UF	µg/L	32	0	0	n/a	n/a	n/a	n/a	0	na	1.237	Reg6	6	n/a	-	0	-
Aldrin	UF	µg/L	31	0	0	n/a	n/a	n/a	n/a	0	na	0.0395	Reg6	6	n/a	-	0	-
Amino-2,6-dinitrotoluene[4-]	UF	µg/L	33	0	0	n/a	n/a	n/a	n/a	n/a	na	na	na	7	n/a	-	n/a	-
Amino-4,6-dinitrotoluene[2-]	UF	µg/L	33	0	0	n/a	n/a	n/a	n/a	n/a	na	na	na	7	n/a	-	n/a	-
Aniline	UF	µg/L	30	0	0	n/a	n/a	n/a	n/a	0	na	117.95	Reg6	6	n/a	-	0	-
Anthracene	UF	µg/L	30	0	0	n/a	n/a	n/a	n/a	0	na	1825	Reg6	6	n/a	-	0	-
Aroclor-1016	UF	µg/L	31	0	0	n/a	n/a	n/a	n/a	0	na	0.5	MCL	6	n/a	-	0	-
Aroclor-1221	UF	µg/L	31	0	0	n/a	n/a	n/a	n/a	0	na	0.5	MCL	6	n/a	-	0	-
Aroclor-1232	UF	µg/L	31	0	0	n/a	n/a	n/a	n/a	0	na	0.5	MCL	6	n/a	-	0	-
Aroclor-1242	UF	µg/L	31	0	0	n/a	n/a	n/a	n/a	0	na	0.5	MCL	6	n/a	-	0	-
Aroclor-1248	UF	µg/L	31	0	0	n/a	n/a	n/a	n/a	0	na	0.5	MCL	6	n/a	-	0	-
Aroclor-1254	UF	µg/L	31	0	0	n/a	n/a	n/a	n/a	0	na	0.5	MCL	6	n/a	-	0	-
Aroclor-1260	UF	µg/L	31	0	0	n/a	n/a	n/a	n/a	0	na	0.5	MCL	6	n/a	-	0	-
Aroclor-1262	UF	µg/L	31	0	0	n/a	n/a	n/a	n/a	0	na	0.5	MCL	6	n/a	-	0	-
Atrazine	UF	µg/L	25	0	0	n/a	n/a	n/a	n/a	0	na	3	MCL	6	n/a	-	0	-
Azobenzene	UF	µg/L	30	0	0	n/a	n/a	n/a	n/a	0	na	6.112	Reg6	6	n/a	-	0	-
BHC[alpha-]	UF	µg/L	31	0	0	n/a	n/a	n/a	n/a	0	na	0.1067	Reg6	6	n/a	-	0	-
BHC[beta-]	UF	µg/L	31	0	0	n/a	n/a	n/a	n/a	0	na	0.3735	Reg6	6	n/a	-	0	-
BHC[delta-]	UF	µg/L	31	1	3.23	0.0122	0.0122	0.0122	n/a	n/a	na	na	na	6	n/a	-	n/a	-
BHC[gamma-]	UF	µg/L	31	0	0	n/a	n/a	n/a	n/a	0	na	0.2	MCL	6	n/a	-	0	-
Benzene	UF	µg/L	32	0	0	n/a	n/a	n/a	n/a	0	na	5	MCL	6	n/a	-	0	-
Benzidine	UF	µg/L	17	0	0	n/a	n/a	n/a	n/a	0	na	0.000936	Reg6	5	n/a	-	0	-
Benzo[a]anthracene	UF	µg/L	29	0	0	n/a	n/a	n/a	n/a	0	na	0.295	Reg6	6	n/a	-	0	-
Benzo[a]pyrene	UF	µg/L	30	0	0	n/a	n/a	n/a	n/a	0	na	0.2	MCL	6	n/a	-	0	-
Benzo[b]fluoranthene	UF	µg/L	30	0	0	n/a	n/a	n/a	n/a	0	na	0.295	Reg6	6	n/a	-	0	-
Benzo[g,h,i]perylene	UF	µg/L	30	0	0	n/a	n/a	n/a	n/a	n/a	na	na	na	6	n/a	-	n/a	-
Benzo[k]fluoranthene	UF	µg/L	30	0	0	n/a	n/a	n/a	n/a	0	na	2.95	Reg6	6	n/a	-	0	-

Table 6.3-7 (continued)

Constituent			Summary by Sample								Screening Values			Location Summary				
Organics	Field Prep	Units	Total	Detects (D)			Exceedances		GW Bkgd ^a	Screening Standard ^b		Locations with Data (Number)	D>Bkgd (Number of Locations)	D>Bkgd Station List ^c	D>Std (Number of Locations)	D>Std Station List ^c		
				Number	Rate (%)	Min.	Median	Max.		D>Bkgd (Number)	D>Std (Number)						Level	Level
Benzoic Acid	UF	µg/L	27	0	0	n/a	n/a	n/a	n/a	0	na	146000	Reg6	6	n/a	-	0	-
Benzyl Alcohol	UF	µg/L	30	0	0	n/a	n/a	n/a	n/a	0	na	10950	Reg6	6	n/a	-	0	-
Bis[2-chloroethoxy]methane	UF	µg/L	27	0	0	n/a	n/a	n/a	n/a	n/a	na	na	na	6	n/a	-	n/a	-
Bis[2-chloroethyl]ether	UF	µg/L	30	0	0	n/a	n/a	n/a	n/a	0	na	0.602	Reg6	6	n/a	-	0	-
Bis[2-ethylhexyl]phthalate	UF	µg/L	30	1	3.33	19.5	19.5	19.5	n/a	1	na	6	MCL	6	n/a	-	1	3
Bromobenzene	UF	µg/L	32	0	0	n/a	n/a	n/a	n/a	0	na	23.25	Reg6	6	n/a	-	0	-
Bromochloromethane	UF	µg/L	32	0	0	n/a	n/a	n/a	n/a	n/a	na	na	na	6	n/a	-	n/a	-
Bromodichloromethane	UF	µg/L	32	0	0	n/a	n/a	n/a	n/a	0	na	10.69	Reg6	6	n/a	-	0	-
Bromoform	UF	µg/L	32	0	0	n/a	n/a	n/a	n/a	0	na	85.1	Reg6	6	n/a	-	0	-
Bromomethane	UF	µg/L	32	0	0	n/a	n/a	n/a	n/a	0	na	8.66	Reg6	6	n/a	-	0	-
Bromophenyl-phenylether[4-]	UF	µg/L	30	0	0	n/a	n/a	n/a	n/a	n/a	na	na	na	6	n/a	-	n/a	-
Butanol[1-]	UF	µg/L	11	0	0	n/a	n/a	n/a	n/a	0	na	3650	Reg6	5	n/a	-	0	-
Butanone[2-]	UF	µg/L	32	4	12.5	3.17	4.515	6.63	n/a	0	na	7064.5	Reg6	6	n/a	-	0	-
Butylbenzene[n-]	UF	µg/L	32	0	0	n/a	n/a	n/a	n/a	0	na	60.83	Reg6	6	n/a	-	0	-
Butylbenzene[sec-]	UF	µg/L	32	0	0	n/a	n/a	n/a	n/a	0	na	60.83	Reg6	6	n/a	-	0	-
Butylbenzene[tert-]	UF	µg/L	32	0	0	n/a	n/a	n/a	n/a	0	na	60.83	Reg6	6	n/a	-	0	-
Butylbenzylphthalate	UF	µg/L	30	0	0	n/a	n/a	n/a	n/a	0	na	7300	Reg6	6	n/a	-	0	-
Carbon Disulfide	UF	µg/L	31	0	0	n/a	n/a	n/a	n/a	0	na	1042.9	Reg6	6	n/a	-	0	-
Carbon Tetrachloride	UF	µg/L	32	0	0	n/a	n/a	n/a	n/a	0	na	5	MCL	6	n/a	-	0	-
Chlordane[alpha-]	UF	µg/L	31	0	0	n/a	n/a	n/a	n/a	0	na	2	MCL	6	n/a	-	0	-
Chlordane[gamma-]	UF	µg/L	31	0	0	n/a	n/a	n/a	n/a	n/a	na	na	na	6	n/a	-	n/a	-
Chloro-1,3-butadiene[2-]	UF	µg/L	32	0	0	n/a	n/a	n/a	n/a	0	na	14.31	Reg6	6	n/a	-	0	-
Chloro-1-propene[3-]	UF	µg/L	32	0	0	n/a	n/a	n/a	n/a	0	na	1825	Reg6	6	n/a	-	0	-
Chloro-3-methylphenol[4-]	UF	µg/L	27	0	0	n/a	n/a	n/a	n/a	n/a	na	na	na	6	n/a	-	n/a	-
Chloroaniline[4-]	UF	µg/L	30	0	0	n/a	n/a	n/a	n/a	0	na	146	Reg6	6	n/a	-	0	-
Chlorobenzene	UF	µg/L	32	0	0	n/a	n/a	n/a	n/a	0	na	100	MCL	6	n/a	-	0	-
Chlorodibromomethane	UF	µg/L	32	0	0	n/a	n/a	n/a	n/a	0	na	7.89	Reg6	6	n/a	-	0	-
Chloroethane	UF	µg/L	32	0	0	n/a	n/a	n/a	n/a	0	na	228.6	Reg6	6	n/a	-	0	-
Chloroethyl vinyl ether[2-]	UF	µg/L	8	0	0	n/a	n/a	n/a	n/a	n/a	na	na	na	6	n/a	-	n/a	-
Chloroform	UF	µg/L	32	18	56.3	0.293	0.642	2.69	n/a	0	na	60	MCL	6	n/a	-	0	-
Chloromethane	UF	µg/L	32	0	0	n/a	n/a	n/a	n/a	0	na	21.35	Reg6	6	n/a	-	0	-
Chloronaphthalene[2-]	UF	µg/L	30	0	0	n/a	n/a	n/a	n/a	0	na	486.7	Reg6	6	n/a	-	0	-
Chlorophenol[2-]	UF	µg/L	27	0	0	n/a	n/a	n/a	n/a	0	na	30.417	Reg6	6	n/a	-	0	-
Chlorophenyl-phenyl[4-] Ether	UF	µg/L	30	0	0	n/a	n/a	n/a	n/a	n/a	na	na	na	6	n/a	-	n/a	-
Chlorotoluene[2-]	UF	µg/L	32	0	0	n/a	n/a	n/a	n/a	0	na	121.67	Reg6	6	n/a	-	0	-
Chlorotoluene[4-]	UF	µg/L	32	0	0	n/a	n/a	n/a	n/a	n/a	na	na	na	6	n/a	-	n/a	-

Table 6.3-7 (continued)

Constituent			Summary by Sample								Screening Values			Location Summary				
Organics	Field Prep	Units	Total	Detects (D)			Exceedances		GW Bkgd ^a	Screening Standard ^b		Locations with Data (Number)	D>Bkgd (Number of Locations)	D>Bkgd Station List ^c	D>Std (Number of Locations)	D>Std Station List ^c		
				Number	Rate (%)	Min.	Median	Max.		D>Bkgd (Number)	D>Std (Number)						Level	Level
Chrysene	UF	µg/L	29	0	0	n/a	n/a	n/a	n/a	0	na	0.2	MCL	6	n/a	-	0	-
DB[2,4-]	UF	µg/L	8	0	0	n/a	n/a	n/a	n/a	0	na	292	Reg6	7	n/a	-	0	-
DDD[4,4'-]	UF	µg/L	31	1	3.23	0.0452	0.0452	0.0452	n/a	0	na	2.801	Reg6	6	n/a	-	0	-
DDE[4,4'-]	UF	µg/L	31	1	3.23	0.0442	0.0442	0.0442	n/a	0	na	1.977	Reg6	6	n/a	-	0	-
DDT[4,4'-]	UF	µg/L	31	1	3.23	0.0452	0.0452	0.0452	n/a	0	na	1.977	Reg6	6	n/a	-	0	-
DNX	UF	µg/L	29	0	0	n/a	n/a	n/a	n/a	n/a	na	na	na	6	n/a	-	n/a	-
D[2,4-]	UF	µg/L	9	0	0	n/a	n/a	n/a	n/a	0	na	70	MCL	7	n/a	-	0	-
Dalapon	UF	µg/L	9	0	0	n/a	n/a	n/a	n/a	0	na	200	MCL	7	n/a	-	0	-
Di-n-butylphthalate	UF	µg/L	30	0	0	n/a	n/a	n/a	n/a	0	na	3650	Reg6	6	n/a	-	0	-
Di-n-octylphthalate	UF	µg/L	30	0	0	n/a	n/a	n/a	n/a	n/a	na	na	na	6	n/a	-	n/a	-
Dibenz[a,h]anthracene	UF	µg/L	30	0	0	n/a	n/a	n/a	n/a	0	na	0.0295	Reg6	6	n/a	-	0	-
Dibenzofuran	UF	µg/L	30	0	0	n/a	n/a	n/a	n/a	0	na	12.167	Reg6	6	n/a	-	0	-
Dibromo-3-Chloropropane[1,2-]	UF	µg/L	32	0	0	n/a	n/a	n/a	n/a	0	na	0.2	MCL	6	n/a	-	0	-
Dibromoethane[1,2-]	UF	µg/L	32	0	0	n/a	n/a	n/a	n/a	0	na	0.05	MCL	6	n/a	-	0	-
Dibromomethane	UF	µg/L	32	0	0	n/a	n/a	n/a	n/a	0	na	60.83	Reg6	6	n/a	-	0	-
Dicamba	UF	µg/L	9	0	0	n/a	n/a	n/a	n/a	0	na	1095	Reg6	7	n/a	-	0	-
Dichlorobenzene[1,2-]	UF	µg/L	32	0	0	n/a	n/a	n/a	n/a	0	na	600	MCL	6	n/a	-	0	-
Dichlorobenzene[1,3-]	UF	µg/L	32	1	3.13	3.25	3.25	3.25	n/a	0	na	600	MCL	6	n/a	-	0	-
Dichlorobenzene[1,4-]	UF	µg/L	32	0	0	n/a	n/a	n/a	n/a	0	na	75	MCL	6	n/a	-	0	-
Dichlorobenzidine[3,3'-]	UF	µg/L	30	0	0	n/a	n/a	n/a	n/a	0	na	1.494	Reg6	6	n/a	-	0	-
Dichlorodifluoromethane	UF	µg/L	30	0	0	n/a	n/a	n/a	n/a	0	na	394.6	Reg6	6	n/a	-	0	-
Dichloroethane[1,1-]	UF	µg/L	32	20	62.5	0.977	2.32	5.89	n/a	0	na	25	NMGSU	6	n/a	-	0	-
Dichloroethane[1,2-]	UF	µg/L	32	0	0	n/a	n/a	n/a	n/a	0	na	5	MCL	6	n/a	-	0	-
Dichloroethene[1,1-]	UF	µg/L	32	20	62.5	1.26	3.595	11.1	n/a	8	na	5	NMGSU	6	n/a	-	3	1, 2, 3
Dichloroethene[cis-1,2-]	UF	µg/L	32	0	0	n/a	n/a	n/a	n/a	0	na	70	MCL	6	n/a	-	0	-
Dichloroethene[trans-1,2-]	UF	µg/L	32	0	0	n/a	n/a	n/a	n/a	0	na	100	MCL	6	n/a	-	0	-
Dichlorophenol[2,4-]	UF	µg/L	27	0	0	n/a	n/a	n/a	n/a	0	na	109.5	Reg6	6	n/a	-	0	-
Dichloropropane[1,2-]	UF	µg/L	32	0	0	n/a	n/a	n/a	n/a	0	na	5	MCL	6	n/a	-	0	-
Dichloropropane[1,3-]	UF	µg/L	32	0	0	n/a	n/a	n/a	n/a	n/a	na	na	na	6	n/a	-	n/a	-
Dichloropropane[2,2-]	UF	µg/L	32	0	0	n/a	n/a	n/a	n/a	n/a	na	na	na	6	n/a	-	n/a	-
Dichloropropene[1,1-]	UF	µg/L	32	0	0	n/a	n/a	n/a	n/a	n/a	na	na	na	6	n/a	-	n/a	-
Dichloropropene[cis-1,3-]	UF	µg/L	32	0	0	n/a	n/a	n/a	n/a	n/a	na	na	na	6	n/a	-	n/a	-
Dichloropropene[cis/trans-1,3-]	UF	µg/L	4	0	0	n/a	n/a	n/a	n/a	0	na	6.71	Reg6	4	n/a	-	0	-
Dichloropropene[trans-1,3-]	UF	µg/L	32	0	0	n/a	n/a	n/a	n/a	n/a	na	na	na	6	n/a	-	n/a	-
Dichloroprop	UF	µg/L	9	0	0	n/a	n/a	n/a	n/a	n/a	na	na	na	7	n/a	-	n/a	-
Dieldrin	UF	µg/L	31	1	3.23	0.0103	0.0103	0.0103	n/a	0	na	0.04202	Reg6	6	n/a	-	0	-

Table 6.3-7 (continued)

Constituent			Summary by Sample								Screening Values			Location Summary				
Organics	Field Prep	Units	Total	Detects (D)			Exceedances		GW Bkgd ^a	Screening Standard ^b		Locations with Data (Number)	D>Bkgd (Number of Locations)	D>Bkgd Station List ^c	D>Std (Number of Locations)	D>Std Station List ^c		
				Number	Rate (%)	Min.	Median	Max.		D>Bkgd (Number)	D>Std (Number)						Level	Level
Diesel Range Organic	UF	µg/L	1	0	0	n/a	n/a	n/a	n/a	n/a	na	na	na	1	n/a	-	n/a	-
Diethyl Ether	UF	µg/L	17	1	5.88	1.44	1.44	1.44	n/a	n/a	na	na	na	6	n/a	-	n/a	-
Diethylphthalate	UF	µg/L	30	0	0	n/a	n/a	n/a	n/a	0	na	29200	Reg6	6	n/a	-	0	-
Dimethyl Phthalate	UF	µg/L	30	0	0	n/a	n/a	n/a	n/a	0	na	365000	Reg6	6	n/a	-	0	-
Dimethylphenol[2,4-]	UF	µg/L	25	0	0	n/a	n/a	n/a	n/a	0	na	730	Reg6	6	n/a	-	0	-
Dinitro-2-methylphenol[4,6-]	UF	µg/L	27	0	0	n/a	n/a	n/a	n/a	n/a	na	na	na	6	n/a	-	n/a	-
Dinitrobenzene[1,3-]	UF	µg/L	33	0	0	n/a	n/a	n/a	n/a	0	na	3.65	Reg6	7	n/a	-	0	-
Dinitrophenol[2,4-]	UF	µg/L	27	0	0	n/a	n/a	n/a	n/a	0	na	73	Reg6	6	n/a	-	0	-
Dinitrotoluene[2,4-]	UF	µg/L	33	0	0	n/a	n/a	n/a	n/a	0	na	73	Reg6	7	n/a	-	0	-
Dinitrotoluene[2,6-]	UF	µg/L	33	0	0	n/a	n/a	n/a	n/a	0	na	36.5	Reg6	7	n/a	-	0	-
Dinoseb	UF	µg/L	29	0	0	n/a	n/a	n/a	n/a	0	na	7	MCL	7	n/a	-	0	-
Dioxane[1,4-]	UF	µg/L	32	20	62.5	8.56	172	1780	n/a	15	na	61.12	Reg6	6	n/a	-	3	1, 2, 3
Diphenylamine	UF	µg/L	30	0	0	n/a	n/a	n/a	n/a	0	na	912.5	Reg6	6	n/a	-	0	-
Endosulfan I	UF	µg/L	31	1	3.23	0.00834	0.00834	0.00834	n/a	n/a	na	na	na	6	n/a	-	n/a	-
Endosulfan II	UF	µg/L	31	1	3.23	0.0122	0.0122	0.0122	n/a	n/a	na	na	na	6	n/a	-	n/a	-
Endosulfan Sulfate	UF	µg/L	31	1	3.23	0.00946	0.00946	0.00946	n/a	n/a	na	na	na	6	n/a	-	n/a	-
Endrin	UF	µg/L	31	1	3.23	0.0145	0.0145	0.0145	n/a	0	na	2	MCL	6	n/a	-	0	-
Endrin Aldehyde	UF	µg/L	31	0	0	n/a	n/a	n/a	n/a	n/a	na	na	na	6	n/a	-	n/a	-
Endrin Ketone	UF	µg/L	31	0	0	n/a	n/a	n/a	n/a	n/a	na	na	na	6	n/a	-	n/a	-
Ethyl Methacrylate	UF	µg/L	32	0	0	n/a	n/a	n/a	n/a	0	na	547.5	Reg6	6	n/a	-	0	-
Ethylbenzene	UF	µg/L	32	0	0	n/a	n/a	n/a	n/a	0	na	700	MCL	6	n/a	-	0	-
Fluoranthene	UF	µg/L	30	0	0	n/a	n/a	n/a	n/a	0	na	1460	Reg6	6	n/a	-	0	-
Fluorene	UF	µg/L	30	0	0	n/a	n/a	n/a	n/a	0	na	243.3	Reg6	6	n/a	-	0	-
HMX	UF	µg/L	33	0	0	n/a	n/a	n/a	n/a	0	na	1825	Reg6	7	n/a	-	0	-
Heptachlor	UF	µg/L	31	0	0	n/a	n/a	n/a	n/a	0	na	0.4	MCL	6	n/a	-	0	-
Heptachlor Epoxide	UF	µg/L	31	0	0	n/a	n/a	n/a	n/a	0	na	0.2	MCL	6	n/a	-	0	-
Hexachlorobenzene	UF	µg/L	30	0	0	n/a	n/a	n/a	n/a	0	na	1	MCL	6	n/a	-	0	-
Hexachlorobutadiene	UF	µg/L	32	0	0	n/a	n/a	n/a	n/a	0	na	8.619	Reg6	6	n/a	-	0	-
Hexachlorocyclopentadiene	UF	µg/L	30	0	0	n/a	n/a	n/a	n/a	0	na	50	MCL	6	n/a	-	0	-
Hexachloroethane	UF	µg/L	30	0	0	n/a	n/a	n/a	n/a	0	na	48.02	Reg6	6	n/a	-	0	-
Hexanone[2-]	UF	µg/L	32	0	0	n/a	n/a	n/a	n/a	n/a	na	na	na	6	n/a	-	n/a	-
Indeno[1,2,3-cd]pyrene	UF	µg/L	30	0	0	n/a	n/a	n/a	n/a	0	na	0.295	Reg6	6	n/a	-	0	-
Iodomethane	UF	µg/L	32	0	0	n/a	n/a	n/a	n/a	n/a	na	na	na	6	n/a	-	n/a	-
Isobutyl alcohol	UF	µg/L	23	0	0	n/a	n/a	n/a	n/a	n/a	na	na	na	6	n/a	-	n/a	-
Isophorone	UF	µg/L	30	0	0	n/a	n/a	n/a	n/a	0	na	707.7	Reg6	6	n/a	-	0	-
Isopropylbenzene	UF	µg/L	32	0	0	n/a	n/a	n/a	n/a	0	na	658.2	Reg6	6	n/a	-	0	-

Table 6.3-7 (continued)

Constituent			Summary by Sample								Screening Values			Location Summary				
Organics	Field Prep	Units	Total	Detects (D)			Exceedances		GW Bkgd ^a	Screening Standard ^b		Locations with Data (Number)	D>Bkgd (Number of Locations)	D>Bkgd Station List ^c	D>Std (Number of Locations)	D>Std Station List ^c		
				Number	Rate (%)	Min.	Median	Max.		D>Bkgd (Number)	D>Std (Number)						Level	Level
Isopropyltoluene[4-]	UF	µg/L	32	0	0	n/a	n/a	n/a	n/a	n/a	na	na	na	6	n/a	-	n/a	-
MCPA	UF	µg/L	9	0	0	n/a	n/a	n/a	n/a	0	na	18.25	Reg6	7	n/a	-	0	-
MCPP	UF	µg/L	9	0	0	n/a	n/a	n/a	n/a	0	na	36.5	Reg6	7	n/a	-	0	-
MNX	UF	µg/L	29	0	0	n/a	n/a	n/a	n/a	n/a	na	na	na	6	n/a	-	n/a	-
Methacrylonitrile	UF	µg/L	32	0	0	n/a	n/a	n/a	n/a	0	na	1.043	Reg6	6	n/a	-	0	-
Methoxychlor[4,4'-]	UF	µg/L	31	0	0	n/a	n/a	n/a	n/a	0	na	40	MCL	6	n/a	-	0	-
Methyl Methacrylate	UF	µg/L	32	0	0	n/a	n/a	n/a	n/a	0	na	1419.4	Reg6	6	n/a	-	0	-
Methyl tert-Butyl Ether	UF	µg/L	17	0	0	n/a	n/a	n/a	n/a	0	na	370.8	Reg6	6	n/a	-	0	-
Methyl-2-pentanone[4-]	UF	µg/L	32	0	0	n/a	n/a	n/a	n/a	0	na	1990.9	Reg6	6	n/a	-	0	-
Methylene Chloride	UF	µg/L	32	0	0	n/a	n/a	n/a	n/a	0	na	5	MCL	6	n/a	-	0	-
Methylnaphthalene[1-]	UF	µg/L	27	0	0	n/a	n/a	n/a	n/a	n/a	na	na	na	6	n/a	-	n/a	-
Methylnaphthalene[2-]	UF	µg/L	29	0	0	n/a	n/a	n/a	n/a	n/a	na	na	na	6	n/a	-	n/a	-
Methylphenol[2-]	UF	µg/L	27	0	0	n/a	n/a	n/a	n/a	0	na	1825	Reg6	6	n/a	-	0	-
Methylphenol[3-,4-]	UF	µg/L	19	0	0	n/a	n/a	n/a	n/a	n/a	na	na	na	6	n/a	-	n/a	-
Methylphenol[4-]	UF	µg/L	8	0	0	n/a	n/a	n/a	n/a	0	na	182.5	Reg6	3	n/a	-	0	-
Naphthalene	UF	µg/L	32	0	0	n/a	n/a	n/a	n/a	0	na	30	NMGSU	6	n/a	-	0	-
Nitroaniline[2-]	UF	µg/L	30	0	0	n/a	n/a	n/a	n/a	0	na	109.5	Reg6	6	n/a	-	0	-
Nitroaniline[3-]	UF	µg/L	30	0	0	n/a	n/a	n/a	n/a	n/a	na	na	na	6	n/a	-	n/a	-
Nitroaniline[4-]	UF	µg/L	30	0	0	n/a	n/a	n/a	n/a	n/a	na	na	na	6	n/a	-	n/a	-
Nitrobenzene	UF	µg/L	33	0	0	n/a	n/a	n/a	n/a	0	na	3.395	Reg6	7	n/a	-	0	-
Nitrophenol[2-]	UF	µg/L	25	0	0	n/a	n/a	n/a	n/a	n/a	na	na	na	6	n/a	-	n/a	-
Nitrophenol[4-]	UF	µg/L	27	0	0	n/a	n/a	n/a	n/a	0	na	292	Reg6	6	n/a	-	0	-
Nitroso-di-n-butylamine[N-]	UF	µg/L	30	0	0	n/a	n/a	n/a	n/a	0	na	0.1227	Reg6	6	n/a	-	0	-
Nitroso-di-n-propylamine[N-]	UF	µg/L	30	0	0	n/a	n/a	n/a	n/a	0	na	0.09604	Reg6	6	n/a	-	0	-
Nitrosodiethylamine[N-]	UF	µg/L	30	0	0	n/a	n/a	n/a	n/a	0	na	0.001436	Reg6	6	n/a	-	0	-
Nitrosodimethylamine[N-]	UF	µg/L	30	0	0	n/a	n/a	n/a	n/a	0	na	0.00422	Reg6	6	n/a	-	0	-
Nitrosopyrrolidine[N-]	UF	µg/L	30	0	0	n/a	n/a	n/a	n/a	0	na	0.3202	Reg6	6	n/a	-	0	-
Nitrotoluene[2-]	UF	µg/L	33	0	0	n/a	n/a	n/a	n/a	0	na	2.923	Reg6	7	n/a	-	0	-
Nitrotoluene[3-]	UF	µg/L	33	0	0	n/a	n/a	n/a	n/a	0	na	121.7	Reg6	7	n/a	-	0	-
Nitrotoluene[4-]	UF	µg/L	33	0	0	n/a	n/a	n/a	n/a	0	na	39.55	Reg6	7	n/a	-	0	-
Oxybis[1-chloropropane][2,2'-]	UF	µg/L	28	0	0	n/a	n/a	n/a	n/a	0	na	9.536	Reg6	6	n/a	-	0	-
PETN	UF	µg/L	31	0	0	n/a	n/a	n/a	n/a	n/a	na	na	na	7	n/a	-	n/a	-
Pentachlorobenzene	UF	µg/L	30	0	0	n/a	n/a	n/a	n/a	0	na	29.2	Reg6	6	n/a	-	0	-
Pentachlorophenol	UF	µg/L	26	0	0	n/a	n/a	n/a	n/a	0	na	1	MCL	6	n/a	-	0	-
Phenanthrene	UF	µg/L	29	0	0	n/a	n/a	n/a	n/a	n/a	na	na	na	6	n/a	-	n/a	-
Phenol	UF	µg/L	27	0	0	n/a	n/a	n/a	n/a	0	na	5	NMGSU	6	n/a	-	0	-

Table 6.3-7 (continued)

Constituent			Summary by Sample								Screening Values			Location Summary				
Organics	Field Prep	Units	Total	Detects (D)			Exceedances		GW Bkgd ^a	Screening Standard ^b		Locations with Data (Number)	D>Bkgd (Number of Locations)	D>Bkgd Station List ^c	D>Std (Number of Locations)	D>Std Station List ^c		
				Number	Rate (%)	Min.	Median	Max.		D>Bkgd (Number)	D>Std (Number)						Level	Level
Propionitrile	UF	µg/L	31	0	0	n/a	n/a	n/a	n/a	n/a	na	na	na	6	n/a	-	n/a	-
Propylbenzene[1-]	UF	µg/L	32	0	0	n/a	n/a	n/a	n/a	0	na	60.83	Reg6	6	n/a	-	0	-
Pyrene	UF	µg/L	29	0	0	n/a	n/a	n/a	n/a	0	na	182.5	Reg6	6	n/a	-	0	-
Pyridine	UF	µg/L	15	0	0	n/a	n/a	n/a	n/a	0	na	36.5	Reg6	6	n/a	-	0	-
RDX	UF	µg/L	33	0	0	n/a	n/a	n/a	n/a	0	na	6.112	Reg6	7	n/a	-	0	-
Styrene	UF	µg/L	32	0	0	n/a	n/a	n/a	n/a	0	na	100	MCL	6	n/a	-	0	-
TATB	UF	µg/L	31	0	0	n/a	n/a	n/a	n/a	n/a	na	na	na	7	n/a	-	n/a	-
TNX	UF	µg/L	29	0	0	n/a	n/a	n/a	n/a	n/a	na	na	na	6	n/a	-	n/a	-
TP[2,4,5-]	UF	µg/L	9	0	0	n/a	n/a	n/a	n/a	0	na	50	MCL	7	n/a	-	0	-
T[2,4,5-]	UF	µg/L	9	0	0	n/a	n/a	n/a	n/a	0	na	365	Reg6	7	n/a	-	0	-
Tetrachlorobenzene[1,2,4,5]	UF	µg/L	30	0	0	n/a	n/a	n/a	n/a	n/a	na	na	na	6	n/a	-	n/a	-
Tetrachloroethane[1,1,1,2-]	UF	µg/L	32	0	0	n/a	n/a	n/a	n/a	0	na	25.5	Reg6	6	n/a	-	0	-
Tetrachloroethane[1,1,2,2-]	UF	µg/L	32	0	0	n/a	n/a	n/a	n/a	0	na	10	NMGSU	6	n/a	-	0	-
Tetrachloroethene	UF	µg/L	32	0	0	n/a	n/a	n/a	n/a	0	na	5	MCL	6	n/a	-	0	-
Tetrachlorophenol[2,3,4,6-]	UF	µg/L	27	0	0	n/a	n/a	n/a	n/a	0	na	5	MCL	6	n/a	-	0	-
Tetryl	UF	µg/L	33	0	0	n/a	n/a	n/a	n/a	0	na	146	Reg6	7	n/a	-	0	-
Toluene	UF	µg/L	32	4	12.5	0.32	2.27	14.7	n/a	0	na	750	NMGSU	6	n/a	-	0	-
TPH Diesel Range Organics	UF	µg/L	16	12	75	31.8	68.8	542	n/a	n/a	na	na	na	4	n/a	-	n/a	-
TPH Gasoline Range Organics	UF	µg/L	10	7	70	27	65.4	101	n/a	n/a	na	na	na	3	n/a	-	n/a	-
Toxaphene [Technical Grade]	UF	µg/L	31	0	0	n/a	n/a	n/a	n/a	0	na	3	MCL	6	n/a	-	0	-
Trichloro-1,2,2-trifluoroethane[1,1,2-]	UF	µg/L	32	0	0	n/a	n/a	n/a	n/a	0	na	59180	Reg6	6	n/a	-	0	-
Trichlorobenzene[1,2,3-]	UF	µg/L	32	0	0	n/a	n/a	n/a	n/a	n/a	na	na	na	6	n/a	-	n/a	-
Trichlorobenzene[1,2,4-]	UF	µg/L	32	0	0	n/a	n/a	n/a	n/a	0	na	70	MCL	6	n/a	-	0	-
Trichloroethane[1,1,1-]	UF	µg/L	32	20	62.5	41.4	98.5	376	n/a	15	na	60	NMGSU	6	n/a	-	3	1, 2, 3
Trichloroethane[1,1,2-]	UF	µg/L	32	1	3.13	0.285	0.285	0.285	n/a	0	na	5	MCL	6	n/a	-	0	-
Trichloroethene	UF	µg/L	32	19	59.4	0.509	1.45	5.23	n/a	1	na	5	MCL	6	n/a	-	1	1
Trichlorofluoromethane	UF	µg/L	31	0	0	n/a	n/a	n/a	n/a	0	na	5	MCL	6	n/a	-	0	-
Trichlorophenol[2,4,5-]	UF	µg/L	27	0	0	n/a	n/a	n/a	n/a	0	na	3650	Reg6	6	n/a	-	0	-
Trichlorophenol[2,4,6-]	UF	µg/L	27	0	0	n/a	n/a	n/a	n/a	0	na	61.12	Reg6	6	n/a	-	0	-
Trichloropropane[1,2,3-]	UF	µg/L	32	0	0	n/a	n/a	n/a	n/a	0	na	0.0947	Reg6	6	n/a	-	0	-
Trimethylbenzene[1,2,4-]	UF	µg/L	32	2	6.25	0.279	0.3825	0.486	n/a	0	na	12.43	Reg6	6	n/a	-	0	-
Trimethylbenzene[1,3,5-]	UF	µg/L	32	0	0	n/a	n/a	n/a	n/a	0	na	12.33	Reg6	6	n/a	-	0	-
Trinitrobenzene[1,3,5-]	UF	µg/L	33	0	0	n/a	n/a	n/a	n/a	0	na	1095	Reg6	7	n/a	-	0	-
Trinitrotoluene[2,4,6-]	UF	µg/L	33	0	0	n/a	n/a	n/a	n/a	0	na	22.41	Reg6	7	n/a	-	0	-
Tris [o-cresyl] phosphate	UF	µg/L	30	0	0	n/a	n/a	n/a	n/a	n/a	na	na	na	7	n/a	-	n/a	-
Vinyl Chloride	UF	µg/L	32	0	0	n/a	n/a	n/a	n/a	0	na	1	NMGSU	6	n/a	-	0	-

Table 6.3-7 (continued)

Constituent			Summary by Sample								Screening Values			Location Summary				
Organics	Field Prep	Units	Total	Detects (D)			Exceedances		GW Bkgd ^a	Screening Standard ^b		Locations with Data (Number)	D>Bkgd (Number of Locations)	D>Bkgd Station List ^c	D>Std (Number of Locations)	D>Std Station List ^c		
				Number	Rate (%)	Min.	Median	Max.		D>Bkgd (Number)	D>Std (Number)						Level	Level
Vinyl acetate	UF	µg/L	31	0	0	n/a	n/a	n/a	n/a	0	na	412.4	Reg6	5	n/a	-	0	-
Xylene[1,2-]	UF	µg/L	32	0	0	n/a	n/a	n/a	n/a	0	na	1431.4	Reg6	6	n/a	-	0	-
Xylene[1,3-]+Xylene[1,4-]	UF	µg/L	32	1	3.13	0.289	0.289	0.289	n/a	n/a	na	na	na	6	n/a	-	n/a	-

Notes: Light grey indicates exceeds groundwater background. Dark grey indicates exceeds standard.

^a Groundwater background UTL or maximum detect for intermediate groundwater filtered samples.

^b Screening Standard

Std Type Standard (Source and Name)
 NMGSF NMAC 20.6.2, Groundwater Standards (Filtered)
 NMGSU NMAC 20.6.2, Groundwater Standards (Unfiltered)
 NMRPS NMEIB Radiation Protection Standards
 MCL EPA MCL
 SMCL EPA SMCL
 Reg6 EPA Region 6 Tap Water Screening Level
 DCG DOE 4-mrem DCG

^c Station List (codes)

1 = 03-B-10 4 = R-19, screen 2
 2 = 03-B-13 5 = R-23i, screen 1
 3 = 03-B-9 6 = R-23i, screen 2
 7 = R-23i, screen 3

^d n/a = Not applicable.

^e na = Not available (no published value).

^f - = None.

Table 6.3-8
Screening Table for Pajarito Watershed General Inorganics in Intermediate Perched Groundwater

Constituent			Summary by Sample								Screening Values			Location Summary				
General Inorganics	Field Prep	Units	Total	Detects (D)			Exceedances		GW Bkgd ^a	Screening Standard ^b		Locations with Data (Number)	D>Bkgd (Number of Locations)	D>Bkgd Station List ^c	D>Std (Number of Locations)	D>Std Station List ^c		
				Number	Rate (%)	Min.	Median	Max.		D>Bkgd (Number)	D>Std (Number)						Level	Level
Alkalinity-CO ³	F	µg/L	32	7	21.9	737	1060	2010	n/a	n/a ^d	na ^e	na	na	7	n/a	- ^f	n/a	-
Alkalinity-CO ³ +HCO ³	F	µg/L	32	32	100	23500	63050	102000	20	n/a	52000	na	na	7	7	1, 2, 3, 4, 5, 6, 7	n/a	-
Ammonia as Nitrogen	F	µg/L	29	3	10.3	65	122	135	2	0	70	208.57	Reg6	6	1	3	0	-
Bromide	F	µg/L	32	10	31.3	108	259.5	904	10	n/a	30	na	na	7	4	1, 2, 3, 6	n/a	-
Calcium	F	µg/L	33	33	100	6960	20300	87800	21	n/a	17310	na	na	7	6	1, 2, 3, 5, 6, 7	n/a	-
Chloride	F	µg/L	32	32	100	2420	53250	610000	23	9	7780	250000	NMGSF	7	4	1, 2, 3, 7	3	1, 2, 3
Cyanide [Total]	F	µg/L	9	2	22.2	2.11	2.895	3.68	n/a	n/a	na	na	na	5	n/a	-	n/a	-
Fluoride	F	µg/L	32	32	100	85	189.5	409	9	0	230	1600	NMGSF	7	5	3, 4, 5, 6, 7	0	-
Hardness	F	µg/L	33	33	100	25200	74400	326000	n/a	n/a	na	na	na	7	n/a	-	n/a	-
Magnesium	F	µg/L	33	33	100	1290	5580	26000	9	n/a	6120	na	na	7	4	1, 2, 3, 6	n/a	-
Nitrate-Nitrite as Nitrogen	F	µg/L	30	25	83.3	29	385	1940	0	0	2410	10000	NMGSF	7	0	-	0	-
Perchlorate	F	µg/L	34	31	91.2	0.0518	0.177	0.551	15	0	0.18	24.5	Reg6	7	5	1, 2, 4, 6, 7	0	-
Potassium	F	µg/L	33	33	100	974	2780	18000	7	n/a	10030	na	na	7	2	1, 2	n/a	-
Silicon Dioxide	F	µg/L	32	32	100	9700	36150	135000	3	n/a	50720	na	na	7	3	1, 2, 4	n/a	-
Sodium	F	µg/L	33	33	100	10600	44300	347000	30	n/a	12190	na	na	7	7	1, 2, 3, 4, 5, 6, 7	n/a	-
Specific Conductance	F	µS/cm	32	32	100	151	332.5	20500	n/a	n/a	na	na	na	7	n/a	-	n/a	-
Sulfate	F	µg/L	32	32	100	2070	8225	14400	0	0	40030	600000	NMGSF	7	0	-	0	-
Sulfide, Total	F	µg/L	2	0	0	n/a	n/a	n/a	n/a	n/a	na	na	na	2	n/a	-	n/a	-
Total Dissolved Solids	F	µg/L	32	32	100	100000	225000	1230000	31	3	127000	1000000	NMGSF	7	7	1, 2, 3, 4, 5, 6, 7	2	1, 2
Total Kjeldahl Nitrogen	F	µg/L	21	13	61.9	51	292	2390	10	n/a	200	na	na	7	4	1, 2, 3, 4	n/a	-
Total Phosphate as Phosphorus	F	µg/L	30	4	13.3	31	126	373	2	n/a	80	na	na	7	2	2, 6	n/a	-
pH	F	SU	32	32	100	5.93	7.5	8.33	n/a	0	na	9	NMGSF	7	n/a	-	0	-
Alkalinity-CO ³	UF	µg/L	7	1	14.3	1780	1780	1780	n/a	n/a	na	na	na	3	n/a	-	n/a	-
Alkalinity-CO ³ +HCO ³	UF	µg/L	7	7	100	32800	56100	70500	n/a	n/a	na	na	na	3	n/a	-	n/a	-
Alkalinity-HCO ³	UF	µg/L	2	2	100	67200	67900	68600	n/a	n/a	na	na	na	1	n/a	-	n/a	-
Ammonia as Nitrogen	UF	µg/L	6	1	16.7	86	86	86	n/a	0	na	208.57	Reg6	3	n/a	-	0	-
Bromide	UF	µg/L	5	2	40	864	870.5	877	n/a	n/a	na	na	na	2	n/a	-	n/a	-
Calcium	UF	µg/L	35	35	100	7430	19900	72400	n/a	n/a	na	na	na	7	n/a	-	n/a	-
Chemical Oxygen Demand	UF	µg/L	4	2	50	47000	47050	47100	n/a	n/a	na	na	na	4	n/a	-	n/a	-
Chloride	UF	µg/L	7	7	100	2700	51800	74900	n/a	n/a	na	na	na	3	n/a	-	n/a	-
Cyanide [Total]	UF	µg/L	28	8	28.6	1.99	4.06	10.5	n/a	n/a	na	na	na	6	n/a	-	n/a	-
Fluoride	UF	µg/L	7	7	100	106	174	674	n/a	0	na	4000	MCL	3	n/a	-	0	-
Hardness	UF	µg/L	35	35	100	26700	73900	276000	n/a	n/a	na	na	na	7	n/a	-	n/a	-
Magnesium	UF	µg/L	35	35	100	1860	5590	23200	n/a	n/a	na	na	na	7	n/a	-	n/a	-

Table 6.3-8 (continued)

Constituent			Summary by Sample								Screening Values			Location Summary				
General Inorganics	Field Prep	Units	Total	Detects (D)			Exceedances		GW Bkgd ^a	Screening Standard ^b		Locations with Data (Number)	D>Bkgd (Number of Locations)	D>Bkgd Station List ^c	D>Std (Number of Locations)	D>Std Station List ^c		
				Number	Rate (%)	Min.	Median	Max.		D>Bkgd (Number)	D>Std (Number)						Level	Level
Nitrate-Nitrite as Nitrogen	UF	µg/L	6	6	100	159	369	606	n/a	0	na	10000	MCL	3	n/a	-	0	-
Perchlorate	UF	µg/L	1	1	100	0.299	0.299	0.299	1	0	0.17	24.5	Reg6	1	1	4	0	-
Potassium	UF	µg/L	35	35	100	998	3060	18000	n/a	n/a	na	na	na	7	n/a	-	n/a	-
Silicon Dioxide	UF	µg/L	8	8	100	30800	67700	166000	n/a	n/a	na	na	na	3	n/a	-	n/a	-
Sodium	UF	µg/L	35	35	100	10300	46400	903000	n/a	n/a	na	na	na	7	n/a	-	n/a	-
Specific Conductance	UF	µS/cm	7	7	100	146	275	368	3	n/a	276.03	na	na	3	2	1, 2	n/a	-
Sulfate	UF	µg/L	7	7	100	3070	4480	9020	n/a	n/a	na	na	na	3	n/a	-	n/a	-
Suspended Sediment Concentration	UF	µg/L	2	1	50	1000000	1000000	1000000	n/a	n/a	na	na	na	2	n/a	-	n/a	-
Total Kjeldahl Nitrogen	UF	µg/L	27	14	51.9	71	514.5	1620	n/a	n/a	na	na	na	6	n/a	-	n/a	-
Total Organic Carbon	UF	µg/L	32	31	96.9	304	2760	10100	n/a	n/a	na	na	na	7	n/a	-	n/a	-
Total Phosphate as Phosphorus	UF	µg/L	7	0	0	n/a	n/a	n/a	n/a	n/a	na	na	na	3	n/a	-	n/a	-
Total Suspended Solids	UF	µg/L	5	2	40	8130	27070	46000	n/a	n/a	na	na	na	4	n/a	-	n/a	-
pH	UF	SU	7	7	100	6.07	6.23	8.34	n/a	n/a	na	na	na	3	n/a	-	n/a	-

Notes: Light grey indicates exceeds groundwater background. Dark grey indicates exceeds standard.

^a Groundwater background UTL or maximum detect for intermediate groundwater filtered samples.

^b Screening Standard
 Std Type Standard (Source and Name)
 NMGSF NMAC 20.6.2, Groundwater Standards (Filtered)
 NMGSU NMAC 20.6.2, Groundwater Standards (Unfiltered)
 NMRPS NMEIB Radiation Protection Standards
 MCL EPA MCL
 SMCL EPA SMCL
 Reg6 EPA Region 6 Tap Water Screening Level
 DCG DOE 4-mrem DCG

^c Station List (codes)
 1 = 03-B-10 4 = R-19, screen 2
 2 = 03-B-13 5 = R-23i, screen 1
 3 = 03-B-9 6 = R-23i, screen 2
 7 = R-23i, screen 3

^d n/a = Not applicable.
^e na = Not available (no published value).
^f - = None.

**Table 6.3-9
Screening Table for Pajarito Watershed Metals in Regional Groundwater**

Constituent			Summary by Sample								Screening Values			Location Summary				
Metals	Field Prep	Units	Total	Detects (D)			Exceedances		GW Bkgd ^a	Screening Standard ^b		Locations with Data (Number)	D>Bkgd (Number of Locations)	D>Bkgd Station List ^c	D>Std (Number of Locations)	D>Std Station List ^c		
				Number	Rate (%)	Min.	Median	Max.		D>Bkgd (Number)	D>Std (Number)						Level	Level
Aluminum	F	µg/L	103	13	12.6	15.6	31.7	168	2	0	73.5	5000	NMGSF	17	2	11, 17	0	- ^d
Antimony	F	µg/L	108	0	0	n/a ^e	n/a	n/a	0	0	1	6	MCL	17	0	-	0	-
Arsenic	F	µg/L	108	23	21.3	1.5	2.6	10.6	0	1	12	10	MCL	17	0	-	1	11
Barium	F	µg/L	108	108	100	6.9	30.3	292	35	0	56.83	1000	NMGSF	17	9	9, 10, 11, 12, 14, 15, 16, 18, 19	0	-
Beryllium	F	µg/L	108	1	0.926	3.9	3.9	3.9	1	0	0.5	4	MCL	17	1	11	0	-
Boron	F	µg/L	108	79	73.1	8.62	14.4	97.3	7	0	38.77	750	NMGSF	17	3	9, 10, 15	0	-
Cadmium	F	µg/L	107	1	0.935	0.06	0.06	0.06	0	0	0.5	5	MCL	17	0	-	0	-
Chromium	F	µg/L	108	64	59.3	0.63	2.65	7	1	0	5.75	50	NMGSF	17	1	14	0	-
Chromium hexavalent ion	F	µg/L	2	2	100	0.058	0.179	0.3	n/a	0	na ^f	50	NMGSF	2	n/a	-	0	-
Cobalt	F	µg/L	108	15	13.9	0.55	3.3	6	0	0	7	50	NMGSF	17	0	-	0	-
Copper	F	µg/L	88	4	4.55	1.4	2.875	15.6	1	0	5	1000	NMGSF	17	1	11	0	-
Iron	F	µg/L	108	49	45.4	12.8	158	11200	25	9	147	1000	NMGSF	17	9	1, 2, 3, 10, 11, 12, 15, 17, 19	4	1, 11, 12, 19
Lead	F	µg/L	108	14	13	0.082	0.4855	2.04	0	0	2.9	15	MCL	17	0	-	0	-
Manganese	F	µg/L	108	53	49.1	2.5	41	3160	23	23	124	200	NMGSF	17	7	10, 11, 12, 15, 16, 17, 19	7	10, 11, 12, 15, 16, 17, 19
Mercury	F	µg/L	108	2	1.85	0.079	0.3045	0.53	1	0	0.26	2	MCL	17	1	19	0	-
Molybdenum	F	µg/L	108	55	50.9	0.53	2.7	31.3	19	0	4.4	1000	NMGSF	17	7	8, 9, 10, 11, 12, 15, 16	0	-
Nickel	F	µg/L	107	64	59.8	0.51	1.3	24.8	0	0	50	100	MCL	17	0	-	0	-
Selenium	F	µg/L	108	6	5.56	1.1	3.4	4.5	2	0	3.93	50	NMGSF	17	2	17, 18	0	-
Silver	F	µg/L	108	1	0.926	0.92	0.92	0.92	0	0	2.5	50	NMGSF	17	0	-	0	-
Strontium	F	µg/L	108	108	100	18	76.25	2070	10	0	540	21900	Reg6	17	3	10, 14, 15	0	-
Thallium	F	µg/L	108	27	25	0.03	0.41	0.95	1	0	0.83	2	MCL	17	1	8	0	-
Tin	F	µg/L	82	0	0	n/a	n/a	n/a	0	0	3.6	21900	Reg6	17	0	-	0	-
Uranium	F	µg/L	108	91	84.3	0.031	0.45	3.1	6	0	1.9	30	NMGSF	17	1	14	0	-
Vanadium	F	µg/L	108	73	67.6	1.2	4.7	8.5	0	0	13.41	182.5	Reg6	17	0	-	0	-
Zinc	F	µg/L	106	47	44.3	1.1	6.1	102	6	0	32	10000	NMGSF	17	4	1, 2, 10, 18	0	-
Aluminum	UF	µg/L	115	31	27	15.3	53.2	3720	n/a	0	na	36500	Reg6	17	n/a	-	0	-
Antimony	UF	µg/L	125	1	0.8	3.7	3.7	3.7	n/a	0	na	6	MCL	19	n/a	-	0	-
Arsenic	UF	µg/L	125	28	22.4	1.5	2.95	8.2	n/a	0	na	10	MCL	19	n/a	-	0	-
Barium	UF	µg/L	125	125	100	11.2	31.7	362	n/a	0	na	2000	MCL	19	n/a	-	0	-
Beryllium	UF	µg/L	118	0	0	n/a	n/a	n/a	n/a	0	na	4	MCL	17	n/a	-	0	-

Table 6.3-9 (continued)

Constituent			Summary by Sample								Screening Values			Location Summary				
Metals	Field Prep	Units	Total	Detects (D)			Exceedances		GW Bkgd ^a	Screening Standard ^b		Locations with Data (Number)	D>Bkgd (Number of Locations)	D>Bkgd Station List ^c	D>Std (Number of Locations)	D>Std Station List ^c		
				Number	Rate (%)	Min.	Median	Max.		D>Bkgd (Number)	D>Std (Number)						Level	Level
Boron	UF	µg/L	125	89	71.2	8.1	14.1	107	n/a	0	na	7300	Reg6	19	n/a	-	0	-
Cadmium	UF	µg/L	124	4	3.23	0.05	0.089	0.14	n/a	0	na	5	MCL	19	n/a	-	0	-
Chromium	UF	µg/L	125	86	68.8	0.518	3.95	37.3	n/a	0	na	100	MCL	19	n/a	-	0	-
Cobalt	UF	µg/L	125	7	5.6	0.559	0.838	1.49	n/a	0	na	730	Reg6	19	n/a	-	0	-
Copper	UF	µg/L	106	15	14.2	1.4	3.2	19.7	n/a	0	na	1300	MCL	19	n/a	-	0	-
Iron	UF	µg/L	125	76	60.8	13.1	163	21100	n/a	0	na	25550	Reg6	19	n/a	-	0	-
Lead	UF	µg/L	125	38	30.4	0.051	0.59	3.73	n/a	0	na	15	Reg6	19	n/a	-	0	-
Manganese	UF	µg/L	125	89	71.2	1.33	28.7	3740	n/a	8	na	1703.09	Reg6	19	n/a	-	2	12, 19
Mercury	UF	µg/L	125	3	2.4	0.29	0.32	0.84	3	0	0.24	2	NMGSU	19	3	10, 14, 19	0	-
Molybdenum	UF	µg/L	125	68	54.4	0.49	2.8	30.8	n/a	0	na	182.5	Reg6	19	n/a	-	0	-
Nickel	UF	µg/L	125	92	73.6	0.52	2.4	31.5	n/a	0	na	100	MCL	19	n/a	-	0	-
Selenium	UF	µg/L	125	9	7.2	1.1	3.4	5.3	1	0	4.99	50	MCL	19	1	9	0	-
Silver	UF	µg/L	125	0	0	n/a	n/a	n/a	0	0	2.5	182.5	Reg6	19	0	-	0	-
Strontium	UF	µg/L	125	125	100	23.6	77.5	2070	n/a	0	na	21900	Reg6	19	n/a	-	0	-
Thallium	UF	µg/L	125	12	9.6	0.026	0.2105	0.526	n/a	0	na	2	MCL	19	n/a	-	0	-
Tin	UF	µg/L	99	2	2.02	2.7	2.85	3	n/a	0	na	21900	Reg6	19	n/a	-	0	-
Uranium	UF	µg/L	125	109	87.2	0.02	0.42	3.8	n/a	0	na	30	MCL	19	n/a	-	0	-
Vanadium	UF	µg/L	125	77	61.6	0.753	4.9	8.6	n/a	0	na	182.5	Reg6	19	n/a	-	0	-
Zinc	UF	µg/L	123	72	58.5	1.12	7.745	202	n/a	0	na	10950	Reg6	19	n/a	-	0	-

Notes: Light grey indicates exceeds groundwater background. Dark grey indicates exceeds standard.

^a Groundwater background UTL or maximum detect for regional groundwater filtered samples; LANL, "Groundwater Background Investigation Report, Revision 3" (2007, 095817).

^b Screening Standard

Std Type	Standard (Source and Name)
NMGSF	NMAC 20.6.2, Groundwater Standards (Filtered)
NMGSU	NMAC 20.6.2, Groundwater Standards (Unfiltered)
NMRPS	NMEIB Radiation Protection Standards
MCL	EPA MCL
SMCL	EPA SMCL
Reg6	EPA Region 6 Tap Water Screening Level
DCG	DOE 4-mrem DCG

^c Station List (codes)

1 = R-17, screen 1	11 = R-20, screen 3
2 = R-17, screen 2	12 = R-22, screen 1
3 = R-18	13 = R-22, screen 2
4 = R-19, screen 3	14 = R-22, screen 3
5 = R-19, screen 4	15 = R-22, screen 4
6 = R-19, screen 5	16 = R-22, screen 5
7 = R-19, screen 6	17 = R-23
8 = R-19, screen 7	18 = R-32, screen 1
9 = R-20, screen 1	19 = R-32, screen 3
10 = R-20, screen 2	

^d - = None.

^e n/a = Not applicable.

^f na = Nnot available (no published value).

Table 6.3-10
Screening Table for Pajarito Watershed Radionuclides in Regional Groundwater

Constituent			Summary by Sample								Screening Values			Location Summary				
Radionuclides	Field Prep	Units	Total	Detects (D)			Exceedances		D>Bkgd (Number)	D>Std (Number)	Gw Bkgd ^a	Screening Standard ^b		Locations with Data (Number)	D>Bkgd (Number of Locations)	D>Bkgd Station List ^c	D>Std (Number of Locations)	D>Std Station List ^c
				Number	Rate (%)	Min.	Median	Max.				Level	Level					
Americium-241	F	pCi/L	78	0	0	n/a ^d	n/a	n/a	0	0	0.032	20	NMRPS	17	0	- ^e	0	-
Cesium-137	F	pCi/L	78	0	0	n/a	n/a	n/a	0	0	4.45	1000	NMRPS	17	0	-	0	-
Cobalt-60	F	pCi/L	78	0	0	n/a	n/a	n/a	n/a	0	na	3000	NMRPS	17	n/a	-	0	-
Gross alpha	F	pCi/L	57	9	15.8	0.847	2.56	5.37	5	0	2.54	15	MCL	17	2	9, 14	0	-
Gross beta	F	pCi/L	57	30	52.6	1.67	4.085	71	1	1	14.1	50	SMCL	17	1	14	1	14
Gross gamma	F	pCi/L	77	0	0	n/a	n/a	n/a	0	n/a	123	na	na	17	0	-	n/a	-
Iodine-129	F	pCi/L	2	0	0	n/a	n/a	n/a	n/a	n/a	na ^f	na	na	2	n/a	-	n/a	-
Neptunium-237	F	pCi/L	77	0	0	n/a	n/a	n/a	n/a	0	na	20	NMRPS	17	n/a	-	0	-
Plutonium-238	F	pCi/L	78	0	0	n/a	n/a	n/a	0	0	0.025	20	NMRPS	17	0	-	0	-
Plutonium-239/240	F	pCi/L	77	1	1.3	0.163	0.163	0.163	n/a	0	na	20	NMRPS	17	n/a	-	0	-
Potassium-40	F	pCi/L	73	0	0	n/a	n/a	n/a	n/a	0	na	4000	NMRPS	16	n/a	-	0	-
Sodium-22	F	pCi/L	75	0	0	n/a	n/a	n/a	n/a	0	na	6000	NMRPS	17	n/a	-	0	-
Strontium-90	F	pCi/L	78	1	1.28	0.378	0.378	0.378	0	0	4.49	8	MCL	17	0	-	0	-
Technetium-99	F	pCi/L	2	0	0	n/a	n/a	n/a	n/a	0	na	4000	DCG	2	n/a	-	0	-
Uranium-234	F	pCi/L	78	74	94.9	0.0607	0.2735	1.57	0	0	2.17	300	NMRPS	17	0	-	0	-
Uranium-235/236	F	pCi/L	78	8	10.3	0.0336	0.05505	0.181	n/a	0	na	300	NMRPS	17	n/a	-	0	-
Uranium-238	F	pCi/L	78	68	87.2	0.0637	0.1575	0.921	0	0	1.2	300	NMRPS	17	0	-	0	-
Americium-241	UF	pCi/L	117	0	0	n/a	n/a	n/a	n/a	0	na	20	NMRPS	17	n/a	-	0	-
Cesium-137	UF	pCi/L	115	0	0	n/a	n/a	n/a	n/a	0	na	1000	NMRPS	17	n/a	-	0	-
Cobalt-60	UF	pCi/L	106	1	0.943	6.5	6.5	6.5	n/a	0	na	3000	NMRPS	17	n/a	-	0	-
Gross alpha	UF	pCi/L	70	18	25.7	0.507	2.135	4.99	n/a	0	na	15	MCL	17	n/a	-	0	-
Gross beta	UF	pCi/L	70	38	54.3	1.65	3.775	10.3	n/a	0	na	50	SMCL	17	n/a	-	0	-
Gross gamma	UF	pCi/L	100	0	0	n/a	n/a	n/a	n/a	n/a	na	na	na	17	n/a	-	n/a	-
Iodine-129	UF	pCi/L	26	0	0	n/a	n/a	n/a	n/a	n/a	na	na	na	8	n/a	-	n/a	-
Neptunium-237	UF	pCi/L	90	0	0	n/a	n/a	n/a	n/a	0	na	20	NMRPS	17	n/a	-	0	-
Plutonium-238	UF	pCi/L	117	0	0	n/a	n/a	n/a	n/a	0	na	20	NMRPS	17	n/a	-	0	-
Plutonium-239/240	UF	pCi/L	115	2	1.74	0.0443	0.05215	0.06	n/a	0	na	20	NMRPS	17	n/a	-	0	-
Potassium-40	UF	pCi/L	105	2	1.9	46	56.2	66.4	n/a	0	na	4000	NMRPS	17	n/a	-	0	-
Radium-226	UF	pCi/L	34	10	29.4	0.442	0.693	1.95	n/a	0	na	5	MCL	15	n/a	-	0	-
Radium-228	UF	pCi/L	22	4	18.2	0.573	1.078	3.97	n/a	0	na	5	MCL	15	n/a	-	0	-
Sodium-22	UF	pCi/L	116	0	0	n/a	n/a	n/a	n/a	0	na	6000	NMRPS	17	n/a	-	0	-
Strontium-90	UF	pCi/L	119	3	2.52	0.229	0.237	4.15	n/a	0	na	8	MCL	17	n/a	-	0	-
Technetium-99	UF	pCi/L	34	0	0	n/a	n/a	n/a	n/a	0	na	4000	DCG	14	n/a	-	0	-
Thorium-228	UF	pCi/L	12	3	25	0.142	0.189	0.266	n/a	n/a	na	na	na	8	n/a	-	n/a	-

Table 6.3-10 (continued)

Constituent			Summary By Sample								Screening Values			Location Summary				
Radionuclides	Field Prep	Units	Total	Detects (D)			Exceedances		D>Bkgd (Number)	D>Std (Number)	Gw Bkgd ^a Level	Screening Standard ^b		Locations with Data (Number)	D>Bkgd (Number of Locations)	D>Bkgd Station List ^c	D>Std (Number of Locations)	D>Std Station List ^c
				Number	Rate (%)	Min.	Median	Max.				Level	Std Type					
Thorium-230	UF	pCi/L	12	2	16.7	0.198	0.277	0.356	n/a	n/a	na	na	na	8	n/a	-	n/a	-
Thorium-232	UF	pCi/L	12	1	8.33	0.342	0.342	0.342	n/a	n/a	na	na	na	8	n/a	-	n/a	-
Tritium	UF	pCi/L	173	43	24.9	-0.1277	2.969	12.87	1	0	11.43	20000	MCL	19	1	16	0	-
Uranium-234	UF	pCi/L	117	100	85.5	0.0575	0.2995	1.87	n/a	0	na	300	NMRPS	17	n/a	-	0	-
Uranium-235/236	UF	pCi/L	117	17	14.5	0.0365	0.0462	0.119	n/a	0	na	300	NMRPS	17	n/a	-	0	-
Uranium-238	UF	pCi/L	117	95	81.2	0.0306	0.152	1	n/a	0	na	300	NMRPS	17	n/a	-	0	-

Notes: Light grey indicates exceeds groundwater background. Dark grey indicates exceeds standard.

^a Groundwater background UTL or maximum detect for regional groundwater filtered samples; LANL "Groundwater Background Investigation Report, Revision 3" (2007, 095817).

^b Screening Standard

Std Type	Standard (Source and Name)
NMGSF	NMAC 20.6.2, Groundwater Standards (Filtered)
NMGSU	NMAC 20.6.2, Groundwater Standards (Unfiltered)
NMRPS	NMEIB Radiation Protection Standards
MCL	EPA MCL
SMCL	EPA SMCL
Reg6	EPA Region 6 Tap Water Screening Level
DCG	DOE 4-mrem DCG

^c Station List (codes)

1 = R-17, Screen 1	11 = R-20, screen 3
2 = R-17, screen 2	12 = R-22, screen 1
3 = R-18	13 = R-22, screen 2
4 = R-19, screen 3	14 = R-22, screen 3
5 = R-19, screen 4	15 = R-22, screen 4
6 = R-19, screen 5	16 = R-22, screen 5
7 = R-19, screen 6	17 = R-23
8 = R-19, screen 7	18 = R-32, screen 1
9 = R-20, screen 1	19 = R-32, screen 3
10 = R-20, screen 2	

^d n/a = Not applicable.

^e - = None.

^f na = Not available (no published value).

Table 6.3-11
Screening Table for Pajarito Watershed Organics in Regional Groundwater

Constituent			Summary by Sample								Screening Values			Location Summary				
Organics	Field Prep	Units	Total	Detects (D)			Exceedances		GW Bkgd ^a	Screening Standard ^b		Locations with Data (Number)	D>Bkgd (Number of Locations)	D>Bkgd Station List ^c	D>Std (Number of Locations)	D>Std Station List ^c		
				Number	Rate (%)	Min.	Median	Max.		D>Bkgd (Number)	D>Std (Number)						Level	Level
2,4-Diamino-6-nitrotoluene	UF	µg/L	73	0	0	n/a ^d	n/a	n/a	n/a	n/a	na ^e	na	na	13	n/a	- ^f	n/a	-
2,6-Diamino-4-nitrotoluene	UF	µg/L	72	1	1.39	0.253	0.253	0.253	n/a	n/a	na	na	na	13	n/a	-	n/a	-
3,5-Dinitroaniline	UF	µg/L	73	0	0	n/a	n/a	n/a	n/a	n/a	na	na	na	13	n/a	-	n/a	-
Acenaphthene	UF	µg/L	118	0	0	n/a	n/a	n/a	n/a	0	na	365	Reg6	17	n/a	-	0	-
Acenaphthylene	UF	µg/L	118	0	0	n/a	n/a	n/a	n/a	n/a	na	na	na	17	n/a	-	n/a	-
Acetone	UF	µg/L	121	17	14	1.29	2.48	209	n/a	0	na	5475	Reg6	17	n/a	-	0	-
Acetonitrile	UF	µg/L	68	1	1.47	9.06	9.06	9.06	n/a	0	na	124.1	Reg6	17	n/a	-	0	-
Acrolein	UF	µg/L	92	0	0	n/a	n/a	n/a	n/a	0	na	0.0416	Reg6	17	n/a	-	0	-
Acrylonitrile	UF	µg/L	102	0	0	n/a	n/a	n/a	n/a	0	na	1.237	Reg6	17	n/a	-	0	-
Aldrin	UF	µg/L	107	0	0	n/a	n/a	n/a	n/a	0	na	0.0395	Reg6	16	n/a	-	0	-
Amino-2,6-dinitrotoluene[4-]	UF	µg/L	112	0	0	n/a	n/a	n/a	n/a	n/a	na	na	na	19	n/a	-	n/a	-
Amino-4,6-dinitrotoluene[2-]	UF	µg/L	108	0	0	n/a	n/a	n/a	n/a	n/a	na	na	na	18	n/a	-	n/a	-
Aniline	UF	µg/L	117	0	0	n/a	n/a	n/a	n/a	0	na	117.95	Reg6	17	n/a	-	0	-
Anthracene	UF	µg/L	118	0	0	n/a	n/a	n/a	n/a	0	na	1825	Reg6	17	n/a	-	0	-
Aroclor-1016	UF	µg/L	113	0	0	n/a	n/a	n/a	n/a	0	na	0.5	MCL	16	n/a	-	0	-
Aroclor-1221	UF	µg/L	113	0	0	n/a	n/a	n/a	n/a	0	na	0.5	MCL	16	n/a	-	0	-
Aroclor-1232	UF	µg/L	113	0	0	n/a	n/a	n/a	n/a	0	na	0.5	MCL	16	n/a	-	0	-
Aroclor-1242	UF	µg/L	113	1	0.885	0.17	0.17	0.17	n/a	0	na	0.5	MCL	16	n/a	-	0	-
Aroclor-1248	UF	µg/L	113	0	0	n/a	n/a	n/a	n/a	0	na	0.5	MCL	16	n/a	-	0	-
Aroclor-1254	UF	µg/L	113	1	0.885	0.11	0.11	0.11	n/a	0	na	0.5	MCL	16	n/a	-	0	-
Aroclor-1260	UF	µg/L	113	0	0	n/a	n/a	n/a	n/a	0	na	0.5	MCL	16	n/a	-	0	-
Aroclor-1262	UF	µg/L	87	0	0	n/a	n/a	n/a	n/a	0	na	0.5	MCL	16	n/a	-	0	-
Atrazine	UF	µg/L	66	0	0	n/a	n/a	n/a	n/a	0	na	3	MCL	17	n/a	-	0	-
Azobenzene	UF	µg/L	118	0	0	n/a	n/a	n/a	n/a	0	na	6.112	Reg6	17	n/a	-	0	-
BHC[alpha-]	UF	µg/L	107	0	0	n/a	n/a	n/a	n/a	0	na	0.1067	Reg6	16	n/a	-	0	-
BHC[beta-]	UF	µg/L	108	0	0	n/a	n/a	n/a	n/a	0	na	0.3735	Reg6	16	n/a	-	0	-
BHC[delta-]	UF	µg/L	108	0	0	n/a	n/a	n/a	n/a	n/a	na	na	na	16	n/a	-	n/a	-
BHC[gamma-]	UF	µg/L	108	0	0	n/a	n/a	n/a	n/a	0	na	0.2	MCL	16	n/a	-	0	-
Benzene	UF	µg/L	123	0	0	n/a	n/a	n/a	n/a	0	na	5	MCL	17	n/a	-	0	-
Benzdine	UF	µg/L	74	0	0	n/a	n/a	n/a	n/a	0	na	0.000936	Reg6	17	n/a	-	0	-
Benzo[a]anthracene	UF	µg/L	118	0	0	n/a	n/a	n/a	n/a	0	na	0.295	Reg6	17	n/a	-	0	-
Benzo[a]pyrene	UF	µg/L	118	0	0	n/a	n/a	n/a	n/a	0	na	0.2	MCL	17	n/a	-	0	-
Benzo[b]fluoranthene	UF	µg/L	118	0	0	n/a	n/a	n/a	n/a	0	na	0.295	Reg6	17	n/a	-	0	-
Benzo[g,h,i]perylene	UF	µg/L	118	0	0	n/a	n/a	n/a	n/a	n/a	na	na	na	17	n/a	-	n/a	-
Benzo[k]fluoranthene	UF	µg/L	118	0	0	n/a	n/a	n/a	n/a	0	na	2.95	Reg6	17	n/a	-	0	-

Table 6.3-11 (continued)

Constituent			Summary by Sample								Screening Values			Location Summary				
Organics	Field Prep	Units	Total	Detects (D)			Exceedances		GW Bkgd ^a	Screening Standard ^b		Locations with Data (Number)	D>Bkgd (Number of Locations)	D>Bkgd Station List ^c	D>Std (Number of Locations)	D>Std Station List ^c		
				Number	Rate (%)	Min.	Median	Max.		D>Bkgd (Number)	D>Std (Number)						Level	Level
Benzoic Acid	UF	µg/L	114	3	2.63	8.46	15.9	18.2	n/a	0	na	146000	Reg6	17	n/a	-	0	-
Benzyl Alcohol	UF	µg/L	118	0	0	n/a	n/a	n/a	n/a	0	na	10950	Reg6	17	n/a	-	0	-
Bis[2-chloroethoxy]methane	UF	µg/L	116	0	0	n/a	n/a	n/a	n/a	n/a	na	na	na	17	n/a	-	n/a	-
Bis[2-chloroethyl]ether	UF	µg/L	118	0	0	n/a	n/a	n/a	n/a	0	na	0.602	Reg6	17	n/a	-	0	-
Bis[2-ethylhexyl]phthalate	UF	µg/L	119	14	11.8	1.5	3.81	7.6	n/a	2	na	6	MCL	17	n/a	-	1	17
Bromobenzene	UF	µg/L	124	0	0	n/a	n/a	n/a	n/a	0	na	23.25	Reg6	17	n/a	-	0	-
Bromochloromethane	UF	µg/L	128	0	0	n/a	n/a	n/a	n/a	n/a	na	na	na	17	n/a	-	n/a	-
Bromodichloromethane	UF	µg/L	128	0	0	n/a	n/a	n/a	n/a	0	na	10.69	Reg6	17	n/a	-	0	-
Bromoform	UF	µg/L	128	1	0.781	1.7	1.7	1.7	n/a	0	na	85.1	Reg6	17	n/a	-	0	-
Bromomethane	UF	µg/L	128	0	0	n/a	n/a	n/a	n/a	0	na	8.66	Reg6	17	n/a	-	0	-
Bromophenyl-phenylether[4-]	UF	µg/L	118	0	0	n/a	n/a	n/a	n/a	n/a	na	na	na	17	n/a	-	n/a	-
Butanol[1-]	UF	µg/L	20	0	0	n/a	n/a	n/a	n/a	0	na	3650	Reg6	10	n/a	-	0	-
Butanone[2-]	UF	µg/L	128	1	0.781	1.6	1.6	1.6	n/a	0	na	7064.5	Reg6	17	n/a	-	0	-
Butylbenzene[n-]	UF	µg/L	128	0	0	n/a	n/a	n/a	n/a	0	na	60.83	Reg6	17	n/a	-	0	-
Butylbenzene[sec-]	UF	µg/L	128	0	0	n/a	n/a	n/a	n/a	0	na	60.83	Reg6	17	n/a	-	0	-
Butylbenzene[tert-]	UF	µg/L	128	0	0	n/a	n/a	n/a	n/a	0	na	60.83	Reg6	17	n/a	-	0	-
Butylbenzylphthalate	UF	µg/L	118	1	0.847	1.6	1.6	1.6	n/a	0	na	7300	Reg6	17	n/a	-	0	-
Carbon Disulfide	UF	µg/L	121	1	0.826	1.62	1.62	1.62	n/a	0	na	1042.9	Reg6	17	n/a	-	0	-
Carbon Tetrachloride	UF	µg/L	128	0	0	n/a	n/a	n/a	n/a	0	na	5	MCL	17	n/a	-	0	-
Chlordane[alpha-]	UF	µg/L	108	0	0	n/a	n/a	n/a	n/a	0	na	2	MCL	16	n/a	-	0	-
Chlordane[gamma-]	UF	µg/L	108	0	0	n/a	n/a	n/a	n/a	n/a	na	na	na	16	n/a	-	n/a	-
Chloro-1,3-butadiene[2-]	UF	µg/L	90	0	0	n/a	n/a	n/a	n/a	0	na	14.31	Reg6	17	n/a	-	0	-
Chloro-1-propene[3-]	UF	µg/L	90	0	0	n/a	n/a	n/a	n/a	0	na	1825	Reg6	17	n/a	-	0	-
Chloro-3-methylphenol[4-]	UF	µg/L	118	0	0	n/a	n/a	n/a	n/a	n/a	na	na	na	17	n/a	-	n/a	-
Chloroaniline[4-]	UF	µg/L	118	0	0	n/a	n/a	n/a	n/a	0	na	146	Reg6	17	n/a	-	0	-
Chlorobenzene	UF	µg/L	128	0	0	n/a	n/a	n/a	n/a	0	na	100	MCL	17	n/a	-	0	-
Chlorodibromomethane	UF	µg/L	128	0	0	n/a	n/a	n/a	n/a	0	na	7.89	Reg6	17	n/a	-	0	-
Chloroethane	UF	µg/L	128	0	0	n/a	n/a	n/a	n/a	0	na	228.6	Reg6	17	n/a	-	0	-
Chloroethyl vinyl ether[2-]	UF	µg/L	16	0	0	n/a	n/a	n/a	n/a	n/a	na	na	na	14	n/a	-	n/a	-
Chloroform	UF	µg/L	128	0	0	n/a	n/a	n/a	n/a	0	na	60	MCL	17	n/a	-	0	-
Chloromethane	UF	µg/L	124	0	0	n/a	n/a	n/a	n/a	0	na	21.35	Reg6	17	n/a	-	0	-
Chloronaphthalene[2-]	UF	µg/L	118	0	0	n/a	n/a	n/a	n/a	0	na	486.7	Reg6	17	n/a	-	0	-
Chlorophenol[2-]	UF	µg/L	118	0	0	n/a	n/a	n/a	n/a	0	na	30.417	Reg6	17	n/a	-	0	-
Chlorophenyl-phenyl[4-] Ether	UF	µg/L	118	0	0	n/a	n/a	n/a	n/a	n/a	na	na	na	17	n/a	-	n/a	-
Chlorotoluene[2-]	UF	µg/L	121	0	0	n/a	n/a	n/a	n/a	0	na	121.67	Reg6	17	n/a	-	0	-
Chlorotoluene[4-]	UF	µg/L	128	0	0	n/a	n/a	n/a	n/a	n/a	na	na	na	17	n/a	-	n/a	-
Chrysene	UF	µg/L	118	0	0	n/a	n/a	n/a	n/a	0	na	0.2	MCL	17	n/a	-	0	-

Table 6.3-11 (continued)

Constituent			Summary by Sample								Screening Values			Location Summary				
Organics	Field Prep	Units	Total	Detects (D)			Exceedances		GW Bkgd ^a	Screening Standard ^b		Locations with Data (Number)	D>Bkgd (Number of Locations)	D>Bkgd Station List ^c	D>Std (Number of Locations)	D>Std Station List ^c		
				Number	Rate (%)	Min.	Median	Max.		D>Bkgd (Number)	D>Std (Number)						Level	Level
DB[2,4-]	UF	µg/L	24	0	0	n/a	n/a	n/a	n/a	0	na	292	Reg6	16	n/a	-	0	-
DDD[4,4'-]	UF	µg/L	107	1	0.935	0.00918	0.00918	0.00918	n/a	0	na	2.801	Reg6	16	n/a	-	0	-
DDE[4,4'-]	UF	µg/L	106	2	1.89	0.00578	0.01284	0.0199	n/a	0	na	1.977	Reg6	16	n/a	-	0	-
DDT[4,4'-]	UF	µg/L	102	1	0.98	0.0148	0.0148	0.0148	n/a	0	na	1.977	Reg6	16	n/a	-	0	-
DNX	UF	µg/L	70	0	0	n/a	n/a	n/a	n/a	n/a	na	na	na	12	n/a	-	n/a	-
D[2,4-]	UF	µg/L	24	0	0	n/a	n/a	n/a	n/a	0	na	70	MCL	16	n/a	-	0	-
Dalapon	UF	µg/L	24	0	0	n/a	n/a	n/a	n/a	0	na	200	MCL	16	n/a	-	0	-
Di-n-butylphthalate	UF	µg/L	113	1	0.885	1.2	1.2	1.2	n/a	0	na	3650	Reg6	17	n/a	-	0	-
Di-n-octylphthalate	UF	µg/L	118	0	0	n/a	n/a	n/a	n/a	n/a	na	na	na	17	n/a	-	n/a	-
Dibenz[a,h]anthracene	UF	µg/L	118	0	0	n/a	n/a	n/a	n/a	0	na	0.0295	Reg6	17	n/a	-	0	-
Dibenzofuran	UF	µg/L	118	0	0	n/a	n/a	n/a	n/a	0	na	12.167	Reg6	17	n/a	-	0	-
Dibromo-3-Chloropropane[1,2-]	UF	µg/L	128	0	0	n/a	n/a	n/a	n/a	0	na	0.2	MCL	17	n/a	-	0	-
Dibromoethane[1,2-]	UF	µg/L	128	0	0	n/a	n/a	n/a	n/a	0	na	0.05	MCL	17	n/a	-	0	-
Dibromomethane	UF	µg/L	128	0	0	n/a	n/a	n/a	n/a	0	na	60.83	Reg6	17	n/a	-	0	-
Dicamba	UF	µg/L	24	0	0	n/a	n/a	n/a	n/a	0	na	1095	Reg6	16	n/a	-	0	-
Dichlorobenzene[1,2-]	UF	µg/L	131	0	0	n/a	n/a	n/a	n/a	0	na	600	MCL	17	n/a	-	0	-
Dichlorobenzene[1,3-]	UF	µg/L	131	0	0	n/a	n/a	n/a	n/a	0	na	600	MCL	17	n/a	-	0	-
Dichlorobenzene[1,4-]	UF	µg/L	131	0	0	n/a	n/a	n/a	n/a	0	na	75	MCL	17	n/a	-	0	-
Dichlorobenzidine[3,3'-]	UF	µg/L	117	0	0	n/a	n/a	n/a	n/a	0	na	1.494	Reg6	17	n/a	-	0	-
Dichlorodifluoromethane	UF	µg/L	127	0	0	n/a	n/a	n/a	n/a	0	na	394.6	Reg6	17	n/a	-	0	-
Dichloroethane[1,1-]	UF	µg/L	128	0	0	n/a	n/a	n/a	n/a	0	na	25	NMGSU	17	n/a	-	0	-
Dichloroethane[1,2-]	UF	µg/L	128	0	0	n/a	n/a	n/a	n/a	0	na	5	MCL	17	n/a	-	0	-
Dichloroethene[1,1-]	UF	µg/L	128	0	0	n/a	n/a	n/a	n/a	0	na	5	NMGSU	17	n/a	-	0	-
Dichloroethene[cis-1,2-]	UF	µg/L	116	0	0	n/a	n/a	n/a	n/a	0	na	70	MCL	17	n/a	-	0	-
Dichloroethene[trans-1,2-]	UF	µg/L	128	0	0	n/a	n/a	n/a	n/a	0	na	100	MCL	17	n/a	-	0	-
Dichlorophenol[2,4-]	UF	µg/L	116	0	0	n/a	n/a	n/a	n/a	0	na	109.5	Reg6	17	n/a	-	0	-
Dichloropropane[1,2-]	UF	µg/L	128	0	0	n/a	n/a	n/a	n/a	0	na	5	MCL	17	n/a	-	0	-
Dichloropropane[1,3-]	UF	µg/L	128	0	0	n/a	n/a	n/a	n/a	n/a	na	na	na	17	n/a	-	n/a	-
Dichloropropane[2,2-]	UF	µg/L	128	0	0	n/a	n/a	n/a	n/a	n/a	na	na	na	17	n/a	-	n/a	-
Dichloropropene[1,1-]	UF	µg/L	128	0	0	n/a	n/a	n/a	n/a	n/a	na	na	na	17	n/a	-	n/a	-
Dichloropropene[cis-1,3-]	UF	µg/L	128	0	0	n/a	n/a	n/a	n/a	n/a	na	na	na	17	n/a	-	n/a	-
Dichloropropene[cis/trans-1,3-]	UF	µg/L	9	0	0	n/a	n/a	n/a	n/a	0	na	6.71	Reg6	9	n/a	-	0	-
Dichloropropene[trans-1,3-]	UF	µg/L	128	0	0	n/a	n/a	n/a	n/a	n/a	na	na	na	17	n/a	-	n/a	-
Dichloroprop	UF	µg/L	24	0	0	n/a	n/a	n/a	n/a	n/a	na	na	na	16	n/a	-	n/a	-
Dieldrin	UF	µg/L	107	0	0	n/a	n/a	n/a	n/a	0	na	0.04202	Reg6	16	n/a	-	0	-
Diethyl Ether	UF	µg/L	47	2	4.26	0.338	0.362	0.386	n/a	n/a	na	na	na	12	n/a	-	n/a	-
Diethylphthalate	UF	µg/L	118	3	2.54	1	1.5	2	n/a	0	na	29200	Reg6	17	n/a	-	0	-

Table 6.3-11 (continued)

Constituent			Summary by Sample								Screening Values			Location Summary				
Organics	Field Prep	Units	Total	Detects (D)			Exceedances		GW Bkgd ^a	Screening Standard ^b		Locations with Data (Number)	D>Bkgd (Number of Locations)	D>Bkgd Station List ^c	D>Std (Number of Locations)	D>Std Station List ^c		
				Number	Rate (%)	Min.	Median	Max.		D>Bkgd (Number)	D>Std (Number)						Level	Level
Dimethyl Phthalate	UF	µg/L	118	0	0	n/a	n/a	n/a	n/a	0	na	365000	Reg6	17	n/a	-	0	-
Dimethylphenol[2,4-]	UF	µg/L	113	0	0	n/a	n/a	n/a	n/a	0	na	730	Reg6	17	n/a	-	0	-
Dinitro-2-methylphenol[4,6-]	UF	µg/L	118	0	0	n/a	n/a	n/a	n/a	n/a	na	na	na	17	n/a	-	n/a	-
Dinitrobenzene[1,3-]	UF	µg/L	113	0	0	n/a	n/a	n/a	n/a	0	na	3.65	Reg6	19	n/a	-	0	-
Dinitrophenol[2,4-]	UF	µg/L	118	0	0	n/a	n/a	n/a	n/a	0	na	73	Reg6	17	n/a	-	0	-
Dinitrotoluene[2,4-]	UF	µg/L	132	0	0	n/a	n/a	n/a	n/a	0	na	73	Reg6	19	n/a	-	0	-
Dinitrotoluene[2,6-]	UF	µg/L	132	0	0	n/a	n/a	n/a	n/a	0	na	36.5	Reg6	19	n/a	-	0	-
Dinoseb	UF	µg/L	88	0	0	n/a	n/a	n/a	n/a	0	na	7	MCL	19	n/a	-	0	-
Dioxane[1,4-]	UF	µg/L	67	0	0	n/a	n/a	n/a	n/a	0	na	61.12	Reg6	12	n/a	-	0	-
Diphenylamine	UF	µg/L	117	0	0	n/a	n/a	n/a	n/a	0	na	912.5	Reg6	17	n/a	-	0	-
Endosulfan I	UF	µg/L	108	0	0	n/a	n/a	n/a	n/a	n/a	na	na	na	16	n/a	-	n/a	-
Endosulfan II	UF	µg/L	108	0	0	n/a	n/a	n/a	n/a	n/a	na	na	na	16	n/a	-	n/a	-
Endosulfan Sulfate	UF	µg/L	108	3	2.78	0.0103	0.0105	0.0175	n/a	n/a	na	na	na	16	n/a	-	n/a	-
Endrin	UF	µg/L	107	0	0	n/a	n/a	n/a	n/a	0	na	2	MCL	16	n/a	-	0	-
Endrin Aldehyde	UF	µg/L	106	1	0.943	0.0334	0.0334	0.0334	n/a	n/a	na	na	na	16	n/a	-	n/a	-
Endrin Ketone	UF	µg/L	107	2	1.87	0.00802	0.009	0.00998	n/a	n/a	na	na	na	16	n/a	-	n/a	-
Ethyl Methacrylate	UF	µg/L	90	0	0	n/a	n/a	n/a	n/a	0	na	547.5	Reg6	17	n/a	-	0	-
Ethylbenzene	UF	µg/L	124	0	0	n/a	n/a	n/a	n/a	0	na	700	MCL	17	n/a	-	0	-
Fluoranthene	UF	µg/L	118	0	0	n/a	n/a	n/a	n/a	0	na	1460	Reg6	17	n/a	-	0	-
Fluorene	UF	µg/L	118	0	0	n/a	n/a	n/a	n/a	0	na	243.3	Reg6	17	n/a	-	0	-
HMX	UF	µg/L	113	1	0.885	0.88	0.88	0.88	n/a	0	na	1825	Reg6	19	n/a	-	0	-
Heptachlor	UF	µg/L	108	0	0	n/a	n/a	n/a	n/a	0	na	0.4	MCL	16	n/a	-	0	-
Heptachlor Epoxide	UF	µg/L	108	0	0	n/a	n/a	n/a	n/a	0	na	0.2	MCL	16	n/a	-	0	-
Hexachlorobenzene	UF	µg/L	118	0	0	n/a	n/a	n/a	n/a	0	na	1	MCL	17	n/a	-	0	-
Hexachlorobutadiene	UF	µg/L	130	0	0	n/a	n/a	n/a	n/a	0	na	8.619	Reg6	17	n/a	-	0	-
Hexachlorocyclopentadiene	UF	µg/L	118	0	0	n/a	n/a	n/a	n/a	0	na	50	MCL	17	n/a	-	0	-
Hexachloroethane	UF	µg/L	118	0	0	n/a	n/a	n/a	n/a	0	na	48.02	Reg6	17	n/a	-	0	-
Hexanone[2-]	UF	µg/L	128	0	0	n/a	n/a	n/a	n/a	n/a	na	na	na	17	n/a	-	n/a	-
Indeno[1,2,3-cd]pyrene	UF	µg/L	118	0	0	n/a	n/a	n/a	n/a	0	na	0.295	Reg6	17	n/a	-	0	-
Iodomethane	UF	µg/L	128	0	0	n/a	n/a	n/a	n/a	n/a	na	na	na	17	n/a	-	n/a	-
Isobutyl alcohol	UF	µg/L	53	0	0	n/a	n/a	n/a	n/a	n/a	na	na	na	16	n/a	-	n/a	-
Isophorone	UF	µg/L	118	0	0	n/a	n/a	n/a	n/a	0	na	707.7	Reg6	17	n/a	-	0	-
Isopropylbenzene	UF	µg/L	128	5	3.91	0.288	0.61	1	n/a	0	na	658.2	Reg6	17	n/a	-	0	-
Isopropyltoluene[4-]	UF	µg/L	128	0	0	n/a	n/a	n/a	n/a	n/a	na	na	na	17	n/a	-	n/a	-
MCPA	UF	µg/L	24	0	0	n/a	n/a	n/a	n/a	0	na	18.25	Reg6	16	n/a	-	0	-
MCPP	UF	µg/L	24	0	0	n/a	n/a	n/a	n/a	0	na	36.5	Reg6	16	n/a	-	0	-
MNX	UF	µg/L	70	0	0	n/a	n/a	n/a	n/a	n/a	na	na	na	12	n/a	-	n/a	-

Table 6.3-11 (continued)

Constituent			Summary by Sample								Screening Values			Location Summary				
Organics	Field Prep	Units	Total	Detects (D)			Exceedances		GW Bkgd ^a	Screening Standard ^b		Locations with Data (Number)	D>Bkgd (Number of Locations)	D>Bkgd Station List ^c	D>Std (Number of Locations)	D>Std Station List ^c		
				Number	Rate (%)	Min.	Median	Max.		D>Bkgd (Number)	D>Std (Number)						Level	Level
Methacrylonitrile	UF	µg/L	90	0	0	n/a	n/a	n/a	n/a	0	na	1.043	Reg6	17	n/a	-	0	-
Methoxychlor[4,4'-]	UF	µg/L	106	0	0	n/a	n/a	n/a	n/a	0	na	40	MCL	16	n/a	-	0	-
Methyl Methacrylate	UF	µg/L	90	1	1.11	1.08	1.08	1.08	n/a	0	na	1419.4	Reg6	17	n/a	-	0	-
Methyl tert-Butyl Ether	UF	µg/L	47	0	0	n/a	n/a	n/a	n/a	0	na	370.8	Reg6	12	n/a	-	0	-
Methyl-2-pentanone[4-]	UF	µg/L	128	2	1.56	1.4	3.675	5.95	n/a	0	na	1990.9	Reg6	17	n/a	-	0	-
Methylene Chloride	UF	µg/L	127	2	1.57	2.38	3.325	4.27	n/a	0	na	5	MCL	17	n/a	-	0	-
Methylnaphthalene[1-]	UF	µg/L	79	0	0	n/a	n/a	n/a	n/a	n/a	na	na	na	17	n/a	-	n/a	-
Methylnaphthalene[2-]	UF	µg/L	117	0	0	n/a	n/a	n/a	n/a	n/a	na	na	na	17	n/a	-	n/a	-
Methylphenol[2-]	UF	µg/L	118	0	0	n/a	n/a	n/a	n/a	0	na	1825	Reg6	17	n/a	-	0	-
Methylphenol[3-,4-]	UF	µg/L	59	0	0	n/a	n/a	n/a	n/a	n/a	na	na	na	17	n/a	-	n/a	-
Methylphenol[4-]	UF	µg/L	59	0	0	n/a	n/a	n/a	n/a	0	na	182.5	Reg6	17	n/a	-	0	-
Methylpyridine[2-]	UF	µg/L	13	0	0	n/a	n/a	n/a	n/a	n/a	na	na	na	9	n/a	-	n/a	-
Naphthalene	UF	µg/L	130	7	5.38	0.24	0.5	0.656	n/a	0	na	30	NMGUSU	17	n/a	-	0	-
Nitroaniline[2-]	UF	µg/L	118	0	0	n/a	n/a	n/a	n/a	0	na	109.5	Reg6	17	n/a	-	0	-
Nitroaniline[3-]	UF	µg/L	118	0	0	n/a	n/a	n/a	n/a	n/a	na	na	na	17	n/a	-	n/a	-
Nitroaniline[4-]	UF	µg/L	118	0	0	n/a	n/a	n/a	n/a	n/a	na	na	na	17	n/a	-	n/a	-
Nitrobenzene	UF	µg/L	132	2	1.52	0.0162	0.0179	0.0196	n/a	0	na	3.395	Reg6	19	n/a	-	0	-
Nitroglycerin	UF	µg/L	1	0	0	n/a	n/a	n/a	n/a	n/a	na	na	na	1	n/a	-	n/a	-
Nitrophenol[2-]	UF	µg/L	108	0	0	n/a	n/a	n/a	n/a	n/a	na	na	na	17	n/a	-	n/a	-
Nitrophenol[4-]	UF	µg/L	115	0	0	n/a	n/a	n/a	n/a	0	na	292	Reg6	17	n/a	-	0	-
Nitroso-di-n-butylamine[N-]	UF	µg/L	80	0	0	n/a	n/a	n/a	n/a	0	na	0.1227	Reg6	17	n/a	-	0	-
Nitroso-di-n-propylamine[N-]	UF	µg/L	118	0	0	n/a	n/a	n/a	n/a	0	na	0.09604	Reg6	17	n/a	-	0	-
Nitrosodiethylamine[N-]	UF	µg/L	80	0	0	n/a	n/a	n/a	n/a	0	na	0.001436	Reg6	17	n/a	-	0	-
Nitrosodimethylamine[N-]	UF	µg/L	118	0	0	n/a	n/a	n/a	n/a	0	na	0.00422	Reg6	17	n/a	-	0	-
Nitrosopyrrolidine[N-]	UF	µg/L	80	0	0	n/a	n/a	n/a	n/a	0	na	0.3202	Reg6	17	n/a	-	0	-
Nitrotoluene[2-]	UF	µg/L	113	0	0	n/a	n/a	n/a	n/a	0	na	2.923	Reg6	19	n/a	-	0	-
Nitrotoluene[3-]	UF	µg/L	113	0	0	n/a	n/a	n/a	n/a	0	na	121.7	Reg6	19	n/a	-	0	-
Nitrotoluene[4-]	UF	µg/L	113	0	0	n/a	n/a	n/a	n/a	0	na	39.55	Reg6	19	n/a	-	0	-
Oxybis[1-chloropropane][2,2'-]	UF	µg/L	116	0	0	n/a	n/a	n/a	n/a	0	na	9.536	Reg6	17	n/a	-	0	-
PETN	UF	µg/L	74	0	0	n/a	n/a	n/a	n/a	n/a	na	na	na	13	n/a	-	n/a	-
Pentachlorobenzene	UF	µg/L	80	0	0	n/a	n/a	n/a	n/a	0	na	29.2	Reg6	17	n/a	-	0	-
Pentachlorophenol	UF	µg/L	116	0	0	n/a	n/a	n/a	n/a	0	na	1	MCL	17	n/a	-	0	-
Phenanthrene	UF	µg/L	114	0	0	n/a	n/a	n/a	n/a	n/a	na	na	na	17	n/a	-	n/a	-
Phenol	UF	µg/L	118	1	0.847	15.8	15.8	15.8	n/a	1	na	5	NMGUSU	17	n/a	-	1	1
Propionitrile	UF	µg/L	70	0	0	n/a	n/a	n/a	n/a	n/a	na	na	na	17	n/a	-	n/a	-
Propylbenzene[1-]	UF	µg/L	124	0	0	n/a	n/a	n/a	n/a	0	na	60.83	Reg6	17	n/a	-	0	-
Pyrene	UF	µg/L	118	0	0	n/a	n/a	n/a	n/a	0	na	182.5	Reg6	17	n/a	-	0	-

Table 6.3-11 (continued)

Constituent			Summary by Sample								Screening Values			Location Summary				
Organics	Field Prep	Units	Total	Detects (D)			Exceedances		GW Bkgd ^a	Screening Standard ^b		Locations with Data (Number)	D>Bkgd (Number of Locations)	D>Bkgd Station List ^c	D>Std (Number of Locations)	D>Std Station List ^c		
				Number	Rate (%)	Min.	Median	Max.		D>Bkgd (Number)	D>Std (Number)						Level	Level
Pyridine	UF	µg/L	50	0	0	n/a	n/a	n/a	n/a	0	na	36.5	Reg6	16	n/a	-	0	-
RDX	UF	µg/L	112	8	7.14	0.134	0.2255	0.396	n/a	0	na	6.112	Reg6	19	n/a	-	0	-
Styrene	UF	µg/L	124	1	0.806	0.501	0.501	0.501	n/a	0	na	100	MCL	17	n/a	-	0	-
TATB	UF	µg/L	73	0	0	n/a	n/a	n/a	n/a	n/a	na	na	na	13	n/a	-	n/a	-
TNX	UF	µg/L	70	0	0	n/a	n/a	n/a	n/a	n/a	na	na	na	12	n/a	-	n/a	-
TP[2,4,5-]	UF	µg/L	24	0	0	n/a	n/a	n/a	n/a	0	na	50	MCL	16	n/a	-	0	-
T[2,4,5-]	UF	µg/L	24	0	0	n/a	n/a	n/a	n/a	0	na	365	Reg6	16	n/a	-	0	-
Tetrachlorobenzene[1,2,4,5]	UF	µg/L	80	0	0	n/a	n/a	n/a	n/a	n/a	na	na	na	17	n/a	-	n/a	-
Tetrachloroethane[1,1,1,2-]	UF	µg/L	128	0	0	n/a	n/a	n/a	n/a	0	na	25.5	Reg6	17	n/a	-	0	-
Tetrachloroethane[1,1,2,2-]	UF	µg/L	128	0	0	n/a	n/a	n/a	n/a	0	na	10	NMGSU	17	n/a	-	0	-
Tetrachloroethene	UF	µg/L	125	1	0.8	0.29	0.29	0.29	n/a	0	na	5	MCL	17	n/a	-	0	-
Tetrachlorophenol[2,3,4,6-]	UF	µg/L	80	0	0	n/a	n/a	n/a	n/a	0	na	5	MCL	17	n/a	-	0	-
Tetryl	UF	µg/L	109	0	0	n/a	n/a	n/a	n/a	0	na	146	Reg6	18	n/a	-	0	-
Toluene	UF	µg/L	128	13	10.2	0.263	0.632	93.2	n/a	0	na	750	NMGSU	17	n/a	-	0	-
TPH Diesel Range Organics	UF	µg/L	2	0	0	n/a	n/a	n/a	n/a	n/a	na	na	na	2	n/a	-	n/a	-
Toxaphene [Technical Grade]	UF	µg/L	108	0	0	n/a	n/a	n/a	n/a	0	na	3	MCL	16	n/a	-	0	-
Trichloro-1,2,2-trifluoroethane[1,1,2-]	UF	µg/L	127	0	0	n/a	n/a	n/a	n/a	0	na	59180	Reg6	17	n/a	-	0	-
Trichlorobenzene[1,2,3-]	UF	µg/L	90	1	1.11	0.592	0.592	0.592	n/a	n/a	na	na	na	17	n/a	-	n/a	-
Trichlorobenzene[1,2,4-]	UF	µg/L	128	0	0	n/a	n/a	n/a	n/a	0	na	70	MCL	17	n/a	-	0	-
Trichloroethane[1,1,1-]	UF	µg/L	126	0	0	n/a	n/a	n/a	n/a	0	na	60	NMGSU	17	n/a	-	0	-
Trichloroethane[1,1,2-]	UF	µg/L	128	0	0	n/a	n/a	n/a	n/a	0	na	5	MCL	17	n/a	-	0	-
Trichloroethene	UF	µg/L	128	0	0	n/a	n/a	n/a	n/a	0	na	5	MCL	17	n/a	-	0	-
Trichlorofluoromethane	UF	µg/L	126	0	0	n/a	n/a	n/a	n/a	0	na	5	MCL	17	n/a	-	0	-
Trichlorophenol[2,4,5-]	UF	µg/L	116	0	0	n/a	n/a	n/a	n/a	0	na	3650	Reg6	17	n/a	-	0	-
Trichlorophenol[2,4,6-]	UF	µg/L	116	0	0	n/a	n/a	n/a	n/a	0	na	61.12	Reg6	17	n/a	-	0	-
Trichloropropane[1,2,3-]	UF	µg/L	128	0	0	n/a	n/a	n/a	n/a	0	na	0.0947	Reg6	17	n/a	-	0	-
Trimethylbenzene[1,2,4-]	UF	µg/L	128	0	0	n/a	n/a	n/a	n/a	0	na	12.43	Reg6	17	n/a	-	0	-
Trimethylbenzene[1,3,5-]	UF	µg/L	128	0	0	n/a	n/a	n/a	n/a	0	na	12.33	Reg6	17	n/a	-	0	-
Trinitrobenzene[1,3,5-]	UF	µg/L	112	0	0	n/a	n/a	n/a	n/a	0	na	1095	Reg6	18	n/a	-	0	-
Trinitrotoluene[2,4,6-]	UF	µg/L	113	0	0	n/a	n/a	n/a	n/a	0	na	22.41	Reg6	19	n/a	-	0	-
Tris [o-cresyl] phosphate	UF	µg/L	63	0	0	n/a	n/a	n/a	n/a	n/a	na	na	na	13	n/a	-	n/a	-

Table 6.3-11 (continued)

Constituent			Summary by Sample								Screening Values			Location Summary				
Organics	Field Prep	Units	Total	Detects (D)			Exceedances		GW Bkgd ^a	Screening Standard ^b		Locations with Data (Number)	D>Bkgd (Number of Locations)	D>Bkgd Station List ^c	D>Std (Number of Locations)	D>Std Station List ^c		
				Number	Rate (%)	Min.	Median	Max.		D>Bkgd (Number)	D>Std (Number)						Level	Level
Vinyl Chloride	UF	µg/L	128	0	0	n/a	n/a	n/a	n/a	0	na	1	NMGSU	17	n/a	-	0	-
Vinyl acetate	UF	µg/L	90	0	0	n/a	n/a	n/a	n/a	0	na	412.4	Reg6	17	n/a	-	0	-
Xylene [Total]	UF	µg/L	38	0	0	n/a	n/a	n/a	n/a	0	na	10000	MCL	15	n/a	-	0	-
Xylene[1,2-]	UF	µg/L	98	0	0	n/a	n/a	n/a	n/a	0	na	1431.4	Reg6	17	n/a	-	0	-
Xylene[1,3-]+Xylene[1,4-]	UF	µg/L	98	3	3.06	0.259	0.28	0.449	n/a	n/a	na	na	na	17	n/a	-	n/a	-

Notes: Light grey indicates exceeds groundwaterbackground. Dark grey indicates exceeds standard.

^a Groundwater background UTL or maximum detect for regional groundwater filtered samples; LANL "Groundwater Background Investigation Report, Revision 3" (2007, 095817).

^b Screening Standard

Std Type	Standard (Source and Name)
NMGSF	NMAC 20.6.2, Groundwater Standards (Filtered)
NMGSU	NMAC 20.6.2, Groundwater Standards (Unfiltered)
NMRPS	NMEIB Radiation Protection Standards
MCL	EPA MCL
SMCL	EPA SMCL
Reg6	EPA Region 6 Tap Water Screening Level
DCG	DOE 4-mrem DCG

^c Station List (codes)

1 = R-17, Screen 1	11 = R-20, screen 3
2 = R-17, screen 2	12 = R-22, screen 1
3 = R-18	13 = R-22, screen 2
4 = R-19, screen 3	14 = R-22, screen 3
5 = R-19, screen 4	15 = R-22, screen 4
6 = R-19, screen 5	16 = R-22, screen 5
7 = R-19, screen 6	17 = R-23
8 = R-19, screen 7	18 = R-32, screen 1
9 = R-20, screen 1	19 = R-32, screen 3
10 = R-20, screen 2	

^d n/a = Not applicable.

^e na = Not available (no published value).

^f - = None.

Table 6.3-12
Screening Table for Pajarito Watershed General Inorganics in Regional Groundwater

Constituent			Summary by Sample								Screening Values			Location Summary				
General Inorganics	Field Prep	Units	Total	Detects (D)					Exceedances		GW Bkgd ^a	Screening Standard ^b		Locations with Data (Number)	D>Bkgd (Number of Locations)	D>Bkgd Station List ^c	D>Std (Number of Locations)	D>Std Station List ^c
				Number	Rate (%)	Min.	Median	Max.	D>Bkgd (Number)	D>Std (Number)		Level	Level					
Alkalinity-CO ³	F	µg/L	102	17	16.7	730	2950	9480	n/a ^d	n/a	na ^e	na	na	17	n/a	- ^f	n/a	-
Alkalinity-CO ³ +HCO ³	F	µg/L	104	104	100	15900	63350	342000	6	n/a	156600	na	na	17	4	10, 12, 15, 16	n/a	-
Alkalinity-HCO ³	F	µg/L	21	21	100	54600	84900	269000	n/a	n/a	na	na	na	6	n/a	-	n/a	-
Ammonia as Nitrogen	F	µg/L	98	34	34.7	21	284	799	21	23	250	208.5714	Reg6	16	8	3, 8, 9, 10, 11, 12, 15, 19	9	3, 8, 9, 10, 11, 12, 15, 16, 19
Bromide	F	µg/L	107	7	6.54	68	166	529	2	n/a	180	na	na	17	2	17, 18	n/a	-
Calcium	F	µg/L	108	108	100	2250	11450	71700	8	n/a	24880	na	na	17	4	10, 12, 15, 16	n/a	-
Chloride	F	µg/L	107	106	99.1	1180	2305	7840	26	0	3570	250000	NMGsf	17	6	9, 10, 12, 14, 15, 17	0	-
Cyanide [Total]	F	µg/L	34	3	8.82	2.63	4.66	62.4	n/a	n/a	na	na	na	17	n/a	-	n/a	-
Dissolved Organic Carbon	F	µg/L	23	23	100	400	1500	9000	n/a	n/a	na	na	na	7	n/a	-	n/a	-
Fluoride	F	µg/L	107	103	96.3	102	325	1310	14	0	570	1600	NMGsf	17	4	10, 11, 15, 19	0	-
Hardness	F	µg/L	82	82	100	8500	39500	267000	n/a	n/a	na	na	na	17	n/a	-	n/a	-
Humic Substances, Hydrophilic Acids	F	µg/L	15	15	100	100	900	2200	n/a	n/a	na	na	na	6	n/a	-	n/a	-
Humic Substances, Hydrophilic Bases	F	µg/L	15	15	100	0	200	400	n/a	n/a	na	na	na	6	n/a	-	n/a	-
Humic Substances, Hydrophilic Neutrals	F	µg/L	15	15	100	0	200	1600	n/a	n/a	na	na	na	6	n/a	-	n/a	-
Humic Substances, Hydrophilic Total	F	µg/L	15	15	100	300	1800	2900	n/a	n/a	na	na	na	6	n/a	-	n/a	-
Humic Substances, Hydrophobic Acids	F	µg/L	15	15	100	100	2000	5400	n/a	n/a	na	na	na	6	n/a	-	n/a	-
Humic Substances, Hydrophobic Bases	F	µg/L	15	15	100	0	0	0	n/a	n/a	na	na	na	6	n/a	-	n/a	-
Humic Substances, Hydrophobic Neutrals	F	µg/L	15	15	100	200	700	2700	n/a	n/a	na	na	na	6	n/a	-	n/a	-
Humic Substances, Hydrophobic Total	F	µg/L	15	15	100	400	2500	6400	n/a	n/a	na	na	na	6	n/a	-	n/a	-
Magnesium	F	µg/L	108	108	100	462	3285	21300	38	n/a	4150	na	na	17	9	10, 11, 12, 13, 14, 15, 16, 17, 18	n/a	-
Nitrate as Nitrogen	F	µg/L	2	1	50	99	99	99	0	0	530	10000	MCL	2	0	-	0	-
Nitrate-Nitrite as Nitrogen	F	µg/L	96	80	83.3	23.5	579.5	1950	17	0	890	10000	NMGsf	17	3	13, 17, 18	0	-
Nitrite as Nitrogen	F	µg/L	2	1	50	58	58	58	1	0	0	1000	MCL	2	1	18	0	-
Oxalate	F	µg/L	2	0	0	n/a	n/a	n/a	n/a	n/a	na	na	na	2	n/a	-	n/a	-
Perchlorate	F	µg/L	79	68	86.1	0.0535	0.2835	0.467	1	0	0.46	24.5	Reg6	17	1	17	0	-
Phosphorus, Orthophosphate [Expressed as PO ₄]	F	µg/L	1	0	0	n/a	n/a	n/a	n/a	n/a	na	na	na	1	n/a	-	n/a	-

Table 6.3-12 (continued)

Constituent			Summary by Sample								Screening Values			Location Summary				
General Inorganics	Field Prep	Units	Total	Detects (D)				Exceedances		GW Bkgd ^a	Screening Standard ^b		Locations with Data (Number)	D>Bkgd (Number of Locations)	D>Bkgd Station List ^c	D>Std (Number of Locations)	D>Std Station List ^c	
				Number	Rate (%)	Min.	Median	Max.	D>Bkgd (Number)		D>Std (Number)	Level						Level
Potassium	F	µg/L	108	108	100	979	1740	6840	23	n/a	2630	na	na	17	7	9, 10, 11, 12, 14, 15, 16	n/a	-
Silicon Dioxide	F	µg/L	106	105	99.1	24100	64300	88000	0	n/a	88500	na	na	17	0	-	n/a	-
Sodium	F	µg/L	108	108	100	7620	11100	101000	14	n/a	24500	na	na	17	6	8, 9, 10, 11, 12, 15	n/a	-
Specific Conductance	F	µg/L	81	81	100	94.2	133	500	n/a	n/a	na	na	na	17	n/a	-	n/a	-
Sulfate	F	µg/L	107	94	87.9	352	2990	23400	5	0	7200	600000	NMGSF	17	4	8, 14, 17, 18	0	-
Total Dissolved Solids	F	µg/L	81	81	100	30000	138000	578000	7	0	191680	1000000	NMGSF	17	7	8, 9, 10, 11, 12, 15, 16	0	-
Total Kjeldahl Nitrogen	F	µg/L	77	47	61	18	406	22900	5	n/a	1000	na	na	17	5	4, 9, 10, 11, 19	n/a	-
Total Phosphate as Phosphorus	F	µg/L	107	42	39.3	19	316.5	3160	21	n/a	340	na	na	17	4	9, 10, 11, 19	n/a	-
pH	F	µg/L	81	81	100	6.54	7.85	9.45	n/a	1	na	9	NMGSF	17	n/a	-	1	2
Alkalinity-CO ³	UF	µg/L	31	7	22.6	733	3040	9230	n/a	n/a	na	na	na	14	n/a	-	n/a	-
Alkalinity-CO ³ +HCO ³	UF	µg/L	31	31	100	40600	68700	280000	n/a	n/a	na	na	na	14	n/a	-	n/a	-
Alkalinity-HCO ³	UF	µg/L	17	17	100	40500	124000	271000	n/a	n/a	na	na	na	10	n/a	-	n/a	-
Ammonia as Nitrogen	UF	µg/L	45	29	64.4	21	337	820	n/a	20	na	208.5714	Reg6	16	n/a	-	10	6, 7, 8, 9, 10, 11, 12, 15, 16, 19
Bromide	UF	µg/L	14	0	0	n/a	n/a	n/a	n/a	n/a	na	na	na	7	n/a	-	n/a	-
Calcium	UF	µg/L	125	125	100	2810	11400	74900	n/a	n/a	na	na	na	19	n/a	-	n/a	-
Chemical Oxygen Demand	UF	µg/L	9	3	33.3	1750	2690	3170	n/a	n/a	na	na	na	9	n/a	-	n/a	-
Chloride	UF	µg/L	31	31	100	1270	2660	9080	n/a	n/a	na	na	na	14	n/a	-	n/a	-
Cyanide [Total]	UF	µg/L	101	14	13.9	1.72	3.77	11.9	n/a	n/a	na	na	na	19	n/a	-	n/a	-
Fluoride	UF	µg/L	31	30	96.8	95	324.5	628	n/a	0	na	4000	MCL	14	n/a	-	0	-
Hardness	UF	µg/L	99	99	100	11200	40600	277000	n/a	n/a	na	na	na	19	n/a	-	n/a	-
Magnesium	UF	µg/L	125	125	100	369	3360	21800	n/a	n/a	na	na	na	19	n/a	-	n/a	-
Nitrate-Nitrite as Nitrogen	UF	µg/L	44	32	72.7	20	594.5	1470	n/a	0	na	10000	MCL	16	n/a	-	0	-
Perchlorate	UF	µg/L	35	18	51.4	0.0626	0.2515	32.5	1	1	0.44	24.5	Reg6	14	1	10	1	10
Phosphorus, Orthophosphate [Expressed as PO ₄]	UF	µg/L	1	0	0	n/a	n/a	n/a	n/a	n/a	na	na	na	1	n/a	-	n/a	-
Potassium	UF	µg/L	125	125	100	1060	1810	6860	n/a	n/a	na	na	na	19	n/a	-	n/a	-
Silicon Dioxide	UF	µg/L	70	70	100	23500	61700	84300	n/a	n/a	na	na	na	17	n/a	-	n/a	-
Sodium	UF	µg/L	125	125	100	8240	11200	99800	n/a	n/a	na	na	na	19	n/a	-	n/a	-
Specific Conductance	UF	µg/L	31	31	100	88.9	170	627	7	n/a	287.21	na	na	14	4	8, 12, 15, 16	n/a	-
Sulfate	UF	µg/L	31	31	100	380	1910	38800	n/a	n/a	na	na	na	14	n/a	-	n/a	-
Suspended Sediment Concentration	UF	µg/L	16	8	50	1200	4000	130000	n/a	n/a	na	na	na	16	n/a	-	n/a	-

Table 6.3-12 (continued)

Constituent			Summary by Sample								Screening Values			Location Summary				
General Inorganics	Field Prep	Units	Total	Detects (D)					Exceedances		GW Bkgd ^a	Screening Standard ^b		Locations with Data (Number)	D>Bkgd (Number of Locations)	D>Bkgd Station List ^c	D>Std (Number of Locations)	D>Std Station List ^c
				Number	Rate (%)	Min.	Median	Max.	D>Bkgd (Number)	D>Std (Number)	Level	Level	Std Type					
Total Kjeldahl Nitrogen	UF	µg/L	87	33	37.9	18	434	3980	n/a	n/a	na	na	na	12	n/a	-	n/a	-
Total Organic Carbon	UF	µg/L	99	85	85.9	178	757	51700	25	n/a	1370	na	na	19	12	1, 6, 8, 9, 10, 11, 12, 14, 15, 16, 17, 18	n/a	-
Total Phosphate as Phosphorus	UF	µg/L	57	29	50.9	19	316	2860	n/a	n/a	na	na	na	17	n/a	-	n/a	-
Total Suspended Solids	UF	µg/L	24	8	33.3	1700	29200	113000	n/a	n/a	na	na	na	14	n/a	-	n/a	-
pH	UF	SU	31	31	100	6.65	7.76	8.62	n/a	n/a	na	na	na	14	n/a	-	n/a	-

Notes: Light grey indicates exceeds groundwaterbackground. Dark grey indicates exceeds standard.

^a Groundwater background UTL or maximum detect for regional groundwater filtered samples; LANL "Groundwater Background Investigation Report, Revision 3" (2007, 095817).

^b Screening Standard

Std Type Standard (Source and Name)
 NMGSF NMAC 20.6.2, Groundwater Standards (Filtered)
 NMGSU NMAC 20.6.2, Groundwater Standards (Unfiltered)
 NMRPS NMEIB Radiation Protection Standards
 MCL EPA MCL
 SMCL EPA SMCL
 Reg6 EPA Region 6 Tap Water Screening Level
 DCG DOE 4-mrem DCG

^c Station List (codes)

1 = R-17, Screen 1 11 = R-20, screen 3
 2 = R-17, screen 2 12 = R-22, screen 1
 3 = R-18 13 = R-22, screen 2
 4 = R-19, screen 3 14 = R-22, screen 3
 5 = R-19, screen 4 15 = R-22, screen 4
 6 = R-19, screen 5 16 = R-22, screen 5
 7 = R-19, screen 6 17 = R-23
 8 = R-19, screen 7 18 = R-32, screen 1
 9 = R-20, screen 1 19 = R-32, screen 3
 10 = R-20, screen 2

^d n/a = Not applicable.

^e na = Not available (no published value).

^f - = None.

Table 6.3-13
Screening Table for Pajarito Watershed Metals in Springs Groundwater

Constituent			Summary by Sample								Screening Values			Location Summary				
Metals	Field Prep	Units	Total	Detects (D)			Exceedances		GW Bkgd ^a	Screening Standard ^b		Locations with Data (Number)	D>Bkgd (Number of Locations)	D>Bkgd Station List ^c	D>Std (Number of Locations)	D>Std Station List ^c		
				Number	Rate (%)	Min.	Median	Max.		D>Bkgd (Number)	D>Std (Number)						Level	Level
Aluminum	F	µg/L	99	69	69.7	27.5	884	12800	30	6	1065.84	5000	NMGSF	15	9	1, 2, 3, 4, 5, 6, 12, 14, 15	4	4, 5, 12, 14
Antimony	F	µg/L	101	1	0.99	4.9	4.9	4.9	1	0	0.5	6	MCL	15	1	14	0	- ^d
Arsenic	F	µg/L	101	19	18.8	1.6	2.6	6.1	4	0	4.32	10	MCL	15	3	7, 9, 11	0	-
Barium	F	µg/L	101	101	100	19.4	45.6	101	11	0	71.83	1000	NMGSF	15	4	2, 5, 13, 15	0	-
Beryllium	F	µg/L	101	0	0	n/a ^e	n/a	n/a	0	0	0.5	4	MCL	15	0	-	0	-
Boron	F	µg/L	101	62	61.4	11	19.1	37.2	46	0	15.12	750	NMGSF	15	14	1, 2, 3, 4, 5, 7, 8, 9, 10, 11, 12, 13, 14, 15	0	-
Cadmium	F	µg/L	101	5	4.95	0.041	0.11	0.14	0	0	0.5	5	MCL	15	0	-	0	-
Chromium	F	µg/L	101	46	45.5	1.1	3.15	9.3	30	0	2.4	50	NMGSF	15	11	1, 2, 4, 5, 6, 7, 8, 9, 10, 11, 12	0	-
Cobalt	F	µg/L	101	14	13.9	1.1	1.65	5.3	11	0	1.2	50	NMGSF	15	7	2, 3, 4, 5, 10, 12, 13	0	-
Copper	F	µg/L	72	9	12.5	1.5	3.4	5.3	0	0	5.32	1000	NMGSF	15	0	-	0	-
Iron	F	µg/L	101	77	76.2	14	410	6720	26	26	839.99	1000	NMGSF	15	8	1, 2, 3, 4, 5, 12, 13, 14	8	1, 2, 3, 4, 5, 12, 13, 14
Lead	F	µg/L	101	31	30.7	0.066	0.91	4	27	0	0.3	15	MCL	15	10	1, 2, 3, 4, 5, 6, 8, 12, 13, 14	0	-
Manganese	F	µg/L	101	53	52.5	2	8.3	302	40	1	3.63	200	NMGSF	15	11	1, 2, 3, 4, 5, 6, 10, 12, 13, 14, 15	1	13
Mercury	F	µg/L	91	4	4.4	0.038	0.085	0.37	4	0	0.03	2	MCL	15	4	3, 4, 5, 13	0	-
Molybdenum	F	µg/L	101	12	11.9	0.24	1.14	3.1	0	0	4.3	1000	NMGSF	15	0	-	0	-
Nickel	F	µg/L	101	71	70.3	0.52	0.99	4.1	0	0	29	100	MCL	15	0	-	0	-
Selenium	F	µg/L	92	4	4.35	1	2.1	2.9	3	0	1.25	50	NMGSF	15	3	4, 5, 11	0	-
Silicon Dioxide	F	µg/L	3	3	100	48700	50700	53300	1	n/a	50720	na ^f	na	3	1	7	n/a	-
Silver	F	µg/L	101	13	12.9	0.23	0.58	2.9	8	0	0.5	50	NMGSF	15	3	3, 5, 12	0	-
Strontium	F	µg/L	101	101	100	55.7	94.7	162	3	0	154.76	21900	Reg6	15	1	10	0	-
Thallium	F	µg/L	101	15	14.9	0.12	0.47	0.68	7	0	0.5	2	MCL	15	6	1, 2, 3, 4, 6, 12	0	-
Tin	F	µg/L	101	3	2.97	2.8	3.1	3.3	3	0	1.25	21900	Reg6	15	3	1, 4, 12	0	-
Uranium	F	µg/L	101	77	76.2	0.052	0.27	1.9	28	0	0.72	30	NMGSF	15	7	1, 6, 7, 8, 9, 10, 11	0	-
Vanadium	F	µg/L	101	80	79.2	1.1	5.05	12.7	41	0	4.91	182.5	Reg6	15	11	1, 2, 4, 5, 7, 8, 9, 10, 11, 12, 14	0	-
Zinc	F	µg/L	97	43	44.3	2.1	5	51.5	1	0	19	10000	NMGSF	15	1	3	0	-
Aluminum	UF	µg/L	91	76	83.5	72.1	1535	13900	n/a	0	na	36500	Reg6	15	n/a	-	0	-
Antimony	UF	µg/L	91	1	1.1	4.5	4.5	4.5	n/a	0	na	6	MCL	15	n/a	-	0	-
Arsenic	UF	µg/L	91	26	28.6	1.5	2.6	7.6	n/a	0	na	10	MCL	15	n/a	-	0	-

Table 6.3-13 (continued)

Constituent			Summary by Sample								Screening Values			Location Summary				
Metals	Field Prep	Units	Total	Detects (D)			Exceedances		GW Bkgd ^a	Screening Standard ^b		Locations with Data (Number)	D>Bkgd (Number of Locations)	D>Bkgd Station List ^c	D>Std (Number of Locations)	D>Std Station List ^c		
				Number	Rate (%)	Min.	Median	Max.		D>Bkgd (Number)	D>Std (Number)						Level	Level
Barium	UF	µg/L	91	91	100	19.6	53.3	115	n/a	0	na	2000	MCL	15	n/a	-	0	-
Beryllium	UF	µg/L	91	0	0	n/a	n/a	n/a	n/a	0	na	4	MCL	15	n/a	-	0	-
Boron	UF	µg/L	91	58	63.7	10.2	18.8	34.1	n/a	0	na	7300	Reg6	15	n/a	-	0	-
Cadmium	UF	µg/L	91	11	12.1	0.1	0.14	0.2	n/a	0	na	5	MCL	15	n/a	-	0	-
Chromium	UF	µg/L	91	51	56	1.1	3.6	6.9	n/a	0	na	100	MCL	15	n/a	-	0	-
Cobalt	UF	µg/L	91	3	3.3	1.2	1.3	1.6	n/a	0	na	730	Reg6	15	n/a	-	0	-
Copper	UF	µg/L	63	18	28.6	3	3.75	51.1	n/a	0	na	1300	MCL	15	n/a	-	0	-
Iron	UF	µg/L	91	83	91.2	25.3	826	6920	n/a	0	na	25550	Reg6	15	n/a	-	0	-
Lead	UF	µg/L	91	44	48.4	0.51	1.6	6	n/a	0	na	15	Reg6	15	n/a	-	0	-
Manganese	UF	µg/L	91	67	73.6	2	14.4	158	n/a	0	na	1703.09	Reg6	15	n/a	-	0	-
Mercury	UF	µg/L	101	6	5.94	0.046	0.0655	0.87	6	0	0.04	2	NMGSU	15	4	5, 10, 12, 13	0	-
Molybdenum	UF	µg/L	91	12	13.2	0.29	0.945	3.8	n/a	0	na	182.5	Reg6	15	n/a	-	0	-
Nickel	UF	µg/L	91	71	78	0.55	1.4	6.3	n/a	0	na	100	MCL	15	n/a	-	0	-
Selenium	UF	µg/L	101	5	4.95	1.1	2.9	5.3	0	0	8.5	50	MCL	15	0	-	0	-
Silver	UF	µg/L	91	23	25.3	0.21	0.72	6	13	0	0.5	182.5	Reg6	15	3	3, 5, 12	0	-
Strontium	UF	µg/L	91	91	100	55.9	95	167	n/a	0	na	21900	Reg6	15	n/a	-	0	-
Thallium	UF	µg/L	91	5	5.49	0.37	0.49	0.56	n/a	0	na	2	MCL	15	n/a	-	0	-
Tin	UF	µg/L	91	2	2.2	3	3.5	4	n/a	0	na	21900	Reg6	15	n/a	-	0	-
Uranium	UF	µg/L	91	69	75.8	0.053	0.41	2	n/a	0	na	30	MCL	15	n/a	-	0	-
Vanadium	UF	µg/L	91	77	84.6	1.2	6.8	13.9	n/a	0	na	182.5	Reg6	15	n/a	-	0	-
Zinc	UF	µg/L	91	45	49.5	2.1	7.6	23.2	n/a	0	na	10950	Reg6	15	n/a	-	0	-

Notes: Light grey indicates exceeds groundwater background. Dark grey indicates exceeds standard.

a Groundwater background UTL or maximum detect for Intermediate Groundwater filtered samples; LANL "Groundwater Background Investigation Report, Revision 3" (2007, 095817).

b Screening Standard

Std Type Standard (Source and Name)
 NMGSF NMAC 20.6.2, Groundwater Standards (Filtered)
 NMGSU NMAC 20.6.2, Groundwater Standards (Unfiltered)
 NMRPS NMEIB Radiation Protection Standards
 MCL EPA MCL
 SMCL EPA SMCL
 Reg6 EPA Region 6 Tap Water Screening Level
 DCG DOE 4mrem DCG

c Station List (codes)

1= Anderson Spring 9 = Spring 4AA
 2 = Bulldog Spring 10 = Spring 4B
 3 = Charlie's Spring 11= Spring 4C
 4 = Homestead Spring 12 = Starmer Spring
 5 = Kieling Spring 13 = TA-18 Spring
 6 = PC Spring 14 = TW-1.72 Spring
 7 = Spring 4 15 = Threemile Spring
 8 = Spring 4A

d - = None.

e n/a=Not applicable.

f na = Not available (no published value).

Table 6.3-14
Screening Table for Pajarito Watershed Radionuclides in Springs Groundwater

Constituent			Summary by Sample								Screening Values			Location Summary				
Radionuclides	Field Prep	Units	Total	Detects (D)			Exceedances		GW Bkgd ^a	Screening Standard ^b		Locations with Data (Number)	D>Bkgd (Number of Locations)	D>Bkgd Station List ^c	D>Std (Number of Locations)	D>Std Station List ^c		
				Number	Rate (%)	Min.	Median	Max.		D>Bkgd (Number)	D>Std (Number)						Level	Level
Americium-241	F	pCi/L	91	0	0	n/a ^d	n/a	n/a	0	0	0.11	20	NMRPS	15	0	- ^e	0	-
Cesium-137	F	pCi/L	92	0	0	n/a	n/a	n/a	0	0	0.76	1000	NMRPS	15	0	-	0	-
Cobalt-60	F	pCi/L	91	0	0	n/a	n/a	n/a	n/a	0	na ^f	3000	NMRPS	15	n/a	-	0	-
Gross alpha	F	pCi/L	71	11	15.5	0.986	1.85	5.78	n/a	0	na	15	MCL	15	n/a	-	0	-
Gross beta	F	pCi/L	71	45	63.4	1.43	3.67	28.9	n/a	0	na	50	SMCL	15	n/a	-	0	-
Gross gamma	F	pCi/L	92	0	0	n/a	n/a	n/a	n/a	n/a	na	na	na	15	n/a	-	n/a	-
Neptunium-237	F	pCi/L	89	0	0	n/a	n/a	n/a	n/a	0	na	20	NMRPS	15	n/a	-	0	-
Plutonium-238	F	pCi/L	92	0	0	n/a	n/a	n/a	0	0	0.01	20	NMRPS	15	0	-	0	-
Plutonium-239/240	F	pCi/L	91	1	1.1	0.855	0.855	0.855	n/a	0	na	20	NMRPS	15	n/a	-	0	-
Potassium-40	F	pCi/L	87	1	1.15	24.8	24.8	24.8	n/a	0	na	4000	NMRPS	15	n/a	-	0	-
Radium-226	F	pCi/L	11	3	27.3	0.681	1.28	1.31	n/a	0	na	5	MCL	8	n/a	-	0	-
Sodium-22	F	pCi/L	92	0	0	n/a	n/a	n/a	n/a	0	na	6000	NMRPS	15	n/a	-	0	-
Strontium-90	F	pCi/L	92	0	0	n/a	n/a	n/a	0	0	0.05	8	MCL	15	0	-	0	-
Thorium-228	F	pCi/L	3	0	0	n/a	n/a	n/a	n/a	n/a	na	na	na	2	n/a	-	n/a	-
Thorium-230	F	pCi/L	3	0	0	n/a	n/a	n/a	n/a	n/a	na	na	na	2	n/a	-	n/a	-
Thorium-232	F	pCi/L	3	0	0	n/a	n/a	n/a	n/a	n/a	na	na	na	2	n/a	-	n/a	-
Uranium-234	F	pCi/L	92	47	51.1	0.0494	0.168	1.13	19	0	0.26	300	NMRPS	15	7	1, 5, 7, 8, 9, 10, 11	0	-
Uranium-235/236	F	pCi/L	92	6	6.52	0.0308	0.053	0.094	n/a	0	na	300	NMRPS	15	n/a	-	0	-
Uranium-238	F	pCi/L	92	48	52.2	0.0426	0.1335	0.626	20	0	0.2	300	NMRPS	15	7	1, 5, 7, 8, 9, 10, 11	0	-
Americium-241	UF	pCi/L	81	0	0	n/a	n/a	n/a	n/a	0	na	20	NMRPS	15	n/a	-	0	-
Cesium-137	UF	pCi/L	79	0	0	n/a	n/a	n/a	n/a	0	na	1000	NMRPS	15	n/a	-	0	-
Cobalt-60	UF	pCi/L	81	0	0	n/a	n/a	n/a	n/a	0	na	3000	NMRPS	15	n/a	-	0	-
Gross alpha	UF	pCi/L	60	19	31.7	0.739	2.72	5.86	n/a	0	na	15	MCL	15	n/a	-	0	-
Gross beta	UF	pCi/L	60	45	75	1.92	3.74	54.9	n/a	1	na	50	SMCL	15	n/a	-	1	3
Gross gamma	UF	pCi/L	81	0	0	n/a	n/a	n/a	n/a	n/a	na	na	na	15	n/a	-	n/a	-
Neptunium-237	UF	pCi/L	81	0	0	n/a	n/a	n/a	n/a	0	na	20	NMRPS	15	n/a	-	0	-
Plutonium-238	UF	pCi/L	81	0	0	n/a	n/a	n/a	n/a	0	na	20	NMRPS	15	n/a	-	0	-
Plutonium-239/240	UF	pCi/L	78	0	0	n/a	n/a	n/a	n/a	0	na	20	NMRPS	15	n/a	-	0	-
Potassium-40	UF	pCi/L	77	0	0	n/a	n/a	n/a	n/a	0	na	4000	NMRPS	15	n/a	-	0	-
Radium-226	UF	pCi/L	5	5	100	0.548	0.579	2.72	n/a	0	na	5	MCL	5	n/a	-	0	-
Radium-228	UF	pCi/L	5	3	60	0.584	0.839	3.13	n/a	0	na	5	MCL	5	n/a	-	0	-
Sodium-22	UF	pCi/L	81	0	0	n/a	n/a	n/a	n/a	0	na	6000	NMRPS	15	n/a	-	0	-

Table 6.3-14 (continued)

Constituent			Summary by Sample								Screening Values			Location Summary				
Radionuclides	Field Prep	Units	Total	Detects (D)			Exceedances		GW Bkgd ^a	Screening Standard ^b		Locations with Data (Number)	D>Bkgd (Number of Locations)	D>Bkgd Station List ^c	D>Std (Number of Locations)	D>Std Station List ^c		
				Number	Rate (%)	Min.	Median	Max.		D>Bkgd (Number)	D>Std (Number)						Level	Level
Strontium-90	UF	pCi/L	81	1	1.23	0.607	0.607	0.607	n/a	0	na	8	MCL	15	n/a	-	0	-
Tritium	UF	pCi/L	90	70	77.8	0.9898	38	462	64	0	7.54	20000	MCL	15	13	1, 2, 3, 4, 5, 6, 7, 8, 10, 11, 12, 13, 15	0	-
Uranium-234	UF	pCi/L	81	58	71.6	0.0316	0.1785	1.08	n/a	0	na	300	NMRPS	15	n/a	-	0	-
Uranium-235/236	UF	pCi/L	81	10	12.3	0.0319	0.0538	0.0753	n/a	0	na	300	NMRPS	15	n/a	-	0	-
Uranium-238	UF	pCi/L	81	54	66.7	0.0354	0.151	1.57	n/a	0	na	300	NMRPS	15	n/a	-	0	-

Notes: Light grey indicates exceeds groundwater background. Dark grey indicates exceeds standard.

^a Groundwater background UTL or maximum detect for Intermediate Groundwater filtered samples; LANL "Groundwater Background Investigation Report, Revision 3" (2007, 095817).

^c Station List (codes)

- | | |
|----------------------|-----------------------|
| 1 = Anderson Spring | 9 = Spring 4AA |
| 2 = Bulldog Spring | 10 = Spring 4B |
| 3 = Charlie's Spring | 11 = Spring 4C |
| 4 = Homestead Spring | 12 = Starmer Spring |
| 5 = Kieling Spring | 13 = TA-18 Spring |
| 6 = PC Spring | 14 = TW-1.72 Spring |
| 7 = Spring 4 | 15 = Threemile Spring |
| 8 = Spring 4A | |

^b Screening Standard

- | | |
|----------|---|
| Std Type | Standard (Source and Name) |
| NMGSF | NMAC 20.6.2, Groundwater Standards (Filtered) |
| NMGUSU | NMAC 20.6.2, Groundwater Standards (Unfiltered) |
| NMRPS | NMEIB Radiation Protection Standards |
| MCL | EPA MCL |
| SMCL | EPA SMCL |
| Reg6 | EPA Region 6 Tap Water Screening Level |
| DCG | DOE 4-mrem DCG |

^d n/a = Not applicable.

^e - = None.

^f na = Not available (no published value).

Table 6.3-15
Screening Table for Pajarito Watershed Organics in Springs Groundwater

Constituent			Summary by Sample								Screening Values			Location Summary				
Organics	Field Prep	Units	Total	Detects (D)			Exceedances		GW Bkgd ^a	Screening Standard ^b		Locations with Data (Number)	D>Bkgd (Number of Locations)	D>Bkgd Station List ^c	D>Std (Number of Locations)	D>Std Station List ^c		
				Number	Rate (%)	Min.	Median	Max.		D>Bkgd (Number)	D>Std (Number)						Level	Level
2,4-Diamino-6-nitrotoluene	UF	µg/L	90	0	0	n/a ^d	n/a	n/a	n/a	n/a	na ^e	na	na	15	n/a	- ^f	n/a	-
2,6-Diamino-4-nitrotoluene	UF	µg/L	89	0	0	n/a	n/a	n/a	n/a	n/a	na	na	na	15	n/a	-	n/a	-
3,5-Dinitroaniline	UF	µg/L	90	0	0	n/a	n/a	n/a	n/a	n/a	na	na	na	15	n/a	-	n/a	-
Acenaphthene	UF	µg/L	99	0	0	n/a	n/a	n/a	n/a	0	na	365	Reg6	15	n/a	-	0	-
Acenaphthylene	UF	µg/L	99	0	0	n/a	n/a	n/a	n/a	n/a	na	na	na	15	n/a	-	n/a	-
Acetone	UF	µg/L	90	17	18.9	1.46	2.8	9.8	n/a	0	na	5475	Reg6	15	n/a	-	0	-
Acetonitrile	UF	µg/L	70	0	0	n/a	n/a	n/a	n/a	0	na	124.1	Reg6	15	n/a	-	0	-
Acrolein	UF	µg/L	86	0	0	n/a	n/a	n/a	n/a	0	na	0.0416	Reg6	15	n/a	-	0	-
Acrylonitrile	UF	µg/L	97	0	0	n/a	n/a	n/a	n/a	0	na	1.237	Reg6	15	n/a	-	0	-
Aldrin	UF	µg/L	87	0	0	n/a	n/a	n/a	n/a	0	na	0.0395	Reg6	15	n/a	-	0	-
Amino-2,6-dinitrotoluene[4-]	UF	µg/L	99	5	5.05	0.135	0.148	0.209	n/a	n/a	na	na	na	15	n/a	-	n/a	-
Amino-4,6-dinitrotoluene[2-]	UF	µg/L	99	0	0	n/a	n/a	n/a	n/a	n/a	na	na	na	15	n/a	-	n/a	-
Aniline	UF	µg/L	98	0	0	n/a	n/a	n/a	n/a	0	na	117.95	Reg6	15	n/a	-	0	-
Anthracene	UF	µg/L	99	0	0	n/a	n/a	n/a	n/a	0	na	1825	Reg6	15	n/a	-	0	-
Aroclor-1016	UF	µg/L	90	0	0	n/a	n/a	n/a	n/a	0	na	0.5	MCL	15	n/a	-	0	-
Aroclor-1221	UF	µg/L	90	0	0	n/a	n/a	n/a	n/a	0	na	0.5	MCL	15	n/a	-	0	-
Aroclor-1232	UF	µg/L	90	0	0	n/a	n/a	n/a	n/a	0	na	0.5	MCL	15	n/a	-	0	-
Aroclor-1242	UF	µg/L	90	0	0	n/a	n/a	n/a	n/a	0	na	0.5	MCL	15	n/a	-	0	-
Aroclor-1248	UF	µg/L	90	0	0	n/a	n/a	n/a	n/a	0	na	0.5	MCL	15	n/a	-	0	-
Aroclor-1254	UF	µg/L	90	0	0	n/a	n/a	n/a	n/a	0	na	0.5	MCL	15	n/a	-	0	-
Aroclor-1260	UF	µg/L	90	0	0	n/a	n/a	n/a	n/a	0	na	0.5	MCL	15	n/a	-	0	-
Aroclor-1262	UF	µg/L	90	0	0	n/a	n/a	n/a	n/a	0	na	0.5	MCL	15	n/a	-	0	-
Atrazine	UF	µg/L	73	0	0	n/a	n/a	n/a	n/a	0	na	3	MCL	15	n/a	-	0	-
Azobenzene	UF	µg/L	99	0	0	n/a	n/a	n/a	n/a	0	na	6.112	Reg6	15	n/a	-	0	-
BHC[alpha-]	UF	µg/L	87	0	0	n/a	n/a	n/a	n/a	0	na	0.1067	Reg6	15	n/a	-	0	-
BHC[beta-]	UF	µg/L	87	0	0	n/a	n/a	n/a	n/a	0	na	0.3735	Reg6	15	n/a	-	0	-
BHC[delta-]	UF	µg/L	87	0	0	n/a	n/a	n/a	n/a	n/a	na	na	na	15	n/a	-	n/a	-
BHC[gamma-]	UF	µg/L	87	0	0	n/a	n/a	n/a	n/a	0	na	0.2	MCL	15	n/a	-	0	-
Benzene	UF	µg/L	90	0	0	n/a	n/a	n/a	n/a	0	na	5	MCL	15	n/a	-	0	-
Benzidine	UF	µg/L	70	0	0	n/a	n/a	n/a	n/a	0	na	0.000936	Reg6	15	n/a	-	0	-
Benzo[a]anthracene	UF	µg/L	99	0	0	n/a	n/a	n/a	n/a	0	na	0.295	Reg6	15	n/a	-	0	-
Benzo[a]pyrene	UF	µg/L	99	1	1.01	0.34	0.34	0.34	n/a	1	na	0.2	MCL	15	n/a	-	1	1
Benzo[b]fluoranthene	UF	µg/L	99	2	2.02	0.305	3.752	7.2	n/a	2	na	0.295	Reg6	15	n/a	-	2	1, 7
Benzo[g,h,i]perylene	UF	µg/L	99	1	1.01	0.636	0.636	0.636	n/a	n/a	na	na	na	15	n/a	-	n/a	-
Benzo[k]fluoranthene	UF	µg/L	99	2	2.02	0.322	0.411	0.5	n/a	0	na	2.95	Reg6	15	n/a	-	0	-

Table 6.3-15 (continued)

Constituent			Summary by Sample								Screening Values			Location Summary				
Organics	Field Prep	Units	Total	Detects (D)					Exceedances		GW Bkgd ^a Level	Screening Standard ^b		Locations with Data (Number)	D>Bkgd (Number of Locations)	D>Bkgd Station List ^c	D>Std (Number of Locations)	D>Std Station List ^c
				Number	Rate (%)	Min.	Median	Max.	D>Bkgd (Number)	D>Std (Number)		Level	Std Type					
Benzoic Acid	UF	µg/L	89	1	1.12	13.8	13.8	13.8	n/a	0	na	146000	Reg6	15	n/a	-	0	-
Benzyl Alcohol	UF	µg/L	99	0	0	n/a	n/a	n/a	n/a	0	na	10950	Reg6	15	n/a	-	0	-
Bis[2-chloroethoxy]methane	UF	µg/L	96	0	0	n/a	n/a	n/a	n/a	n/a	na	na	na	15	n/a	-	n/a	-
Bis[2-chloroethyl]ether	UF	µg/L	99	0	0	n/a	n/a	n/a	n/a	0	na	0.602	Reg6	15	n/a	-	0	-
Bis[2-ethylhexyl]phthalate	UF	µg/L	99	2	2.02	2.67	2.705	2.74	n/a	0	na	6	MCL	15	n/a	-	0	-
Bromobenzene	UF	µg/L	93	0	0	n/a	n/a	n/a	n/a	0	na	23.25	Reg6	15	n/a	-	0	-
Bromochloromethane	UF	µg/L	97	0	0	n/a	n/a	n/a	n/a	n/a	na	na	na	15	n/a	-	n/a	-
Bromodichloromethane	UF	µg/L	97	0	0	n/a	n/a	n/a	n/a	0	na	10.69	Reg6	15	n/a	-	0	-
Bromoform	UF	µg/L	97	0	0	n/a	n/a	n/a	n/a	0	na	85.1	Reg6	15	n/a	-	0	-
Bromomethane	UF	µg/L	97	0	0	n/a	n/a	n/a	n/a	0	na	8.66	Reg6	15	n/a	-	0	-
Bromophenyl-phenylether[4-]	UF	µg/L	99	0	0	n/a	n/a	n/a	n/a	n/a	na	na	na	15	n/a	-	n/a	-
Butanol[1-]	UF	µg/L	15	0	0	n/a	n/a	n/a	n/a	0	na	3650	Reg6	8	n/a	-	0	-
Butanone[2-]	UF	µg/L	97	16	16.5	1.33	2.13	7.95	n/a	0	na	7064.5	Reg6	15	n/a	-	0	-
Butylbenzene[n-]	UF	µg/L	96	0	0	n/a	n/a	n/a	n/a	0	na	60.83	Reg6	15	n/a	-	0	-
Butylbenzene[sec-]	UF	µg/L	96	0	0	n/a	n/a	n/a	n/a	0	na	60.83	Reg6	15	n/a	-	0	-
Butylbenzene[tert-]	UF	µg/L	96	0	0	n/a	n/a	n/a	n/a	0	na	60.83	Reg6	15	n/a	-	0	-
Butylbenzylphthalate	UF	µg/L	99	0	0	n/a	n/a	n/a	n/a	0	na	7300	Reg6	15	n/a	-	0	-
Carbon Disulfide	UF	µg/L	93	0	0	n/a	n/a	n/a	n/a	0	na	1042.9	Reg6	15	n/a	-	0	-
Carbon Tetrachloride	UF	µg/L	97	0	0	n/a	n/a	n/a	n/a	0	na	5	MCL	15	n/a	-	0	-
Chlordane[alpha-]	UF	µg/L	87	0	0	n/a	n/a	n/a	n/a	0	na	2	MCL	15	n/a	-	0	-
Chlordane[gamma-]	UF	µg/L	87	1	1.15	0.00564	0.00564	0.00564	n/a	n/a	na	na	na	15	n/a	-	n/a	-
Chloro-1,3-butadiene[2-]	UF	µg/L	88	0	0	n/a	n/a	n/a	n/a	0	na	14.31	Reg6	15	n/a	-	0	-
Chloro-1-propene[3-]	UF	µg/L	88	0	0	n/a	n/a	n/a	n/a	0	na	1825	Reg6	15	n/a	-	0	-
Chloro-3-methylphenol[4-]	UF	µg/L	89	0	0	n/a	n/a	n/a	n/a	n/a	na	na	na	15	n/a	-	n/a	-
Chloroaniline[4-]	UF	µg/L	99	0	0	n/a	n/a	n/a	n/a	0	na	146	Reg6	15	n/a	-	0	-
Chlorobenzene	UF	µg/L	97	0	0	n/a	n/a	n/a	n/a	0	na	100	MCL	15	n/a	-	0	-
Chlorodibromomethane	UF	µg/L	97	0	0	n/a	n/a	n/a	n/a	0	na	7.89	Reg6	15	n/a	-	0	-
Chloroethane	UF	µg/L	97	0	0	n/a	n/a	n/a	n/a	0	na	228.6	Reg6	15	n/a	-	0	-
Chloroethyl vinyl ether[2-]	UF	µg/L	13	0	0	n/a	n/a	n/a	n/a	n/a	na	na	na	8	n/a	-	n/a	-
Chloroform	UF	µg/L	97	5	5.15	0.332	0.364	0.405	n/a	0	na	60	MCL	15	n/a	-	0	-
Chloromethane	UF	µg/L	92	0	0	n/a	n/a	n/a	n/a	0	na	21.35	Reg6	15	n/a	-	0	-
Chloronaphthalene[2-]	UF	µg/L	99	0	0	n/a	n/a	n/a	n/a	0	na	486.7	Reg6	15	n/a	-	0	-
Chlorophenol[2-]	UF	µg/L	89	1	1.12	0.43	0.43	0.43	n/a	0	na	30.417	Reg6	15	n/a	-	0	-
Chlorophenyl-phenyl[4-] Ether	UF	µg/L	99	0	0	n/a	n/a	n/a	n/a	n/a	na	na	na	15	n/a	-	n/a	-
Chlorotoluene[2-]	UF	µg/L	92	0	0	n/a	n/a	n/a	n/a	0	na	121.67	Reg6	15	n/a	-	0	-
Chlorotoluene[4-]	UF	µg/L	97	0	0	n/a	n/a	n/a	n/a	n/a	na	na	na	15	n/a	-	n/a	-
Chrysene	UF	µg/L	99	0	0	n/a	n/a	n/a	n/a	0	na	0.2	MCL	15	n/a	-	0	-

Table 6.3-15 (continued)

Constituent			Summary by Sample								Screening Values			Location Summary				
Organics	Field Prep	Units	Total	Detects (D)			Exceedances		GW Bkgd ^a	Screening Standard ^b		Locations with Data (Number)	D>Bkgd (Number of Locations)	D>Bkgd Station List ^c	D>Std (Number of Locations)	D>Std Station List ^c		
				Number	Rate (%)	Min.	Median	Max.		D>Bkgd (Number)	D>Std (Number)						Level	Level
DB[2,4-]	UF	µg/L	13	0	0	n/a	n/a	n/a	n/a	0	na	292	Reg6	8	n/a	-	0	-
DDD[4,4'-]	UF	µg/L	87	1	1.15	0.0233	0.0233	0.0233	n/a	0	na	2.801	Reg6	15	n/a	-	0	-
DDE[4,4'-]	UF	µg/L	87	1	1.15	0.022	0.022	0.022	n/a	0	na	1.977	Reg6	15	n/a	-	0	-
DDT[4,4'-]	UF	µg/L	87	1	1.15	0.0173	0.0173	0.0173	n/a	0	na	1.977	Reg6	15	n/a	-	0	-
DNX	UF	µg/L	80	0	0	n/a	n/a	n/a	n/a	n/a	na	na	na	14	n/a	-	n/a	-
D[2,4-]	UF	µg/L	15	0	0	n/a	n/a	n/a	n/a	0	na	70	MCL	8	n/a	-	0	-
Dalapon	UF	µg/L	15	0	0	n/a	n/a	n/a	n/a	0	na	200	MCL	8	n/a	-	0	-
Di-n-butylphthalate	UF	µg/L	98	0	0	n/a	n/a	n/a	n/a	0	na	3650	Reg6	15	n/a	-	0	-
Di-n-octylphthalate	UF	µg/L	99	0	0	n/a	n/a	n/a	n/a	n/a	na	na	na	15	n/a	-	n/a	-
Dibenz[a,h]anthracene	UF	µg/L	99	1	1.01	3.16	3.16	3.16	n/a	1	na	0.0295	Reg6	15	n/a	-	1	1
Dibenzofuran	UF	µg/L	94	0	0	n/a	n/a	n/a	n/a	0	na	12.167	Reg6	15	n/a	-	0	-
Dibromo-3-Chloropropane[1,2-]	UF	µg/L	97	0	0	n/a	n/a	n/a	n/a	0	na	0.2	MCL	15	n/a	-	0	-
Dibromoethane[1,2-]	UF	µg/L	97	0	0	n/a	n/a	n/a	n/a	0	na	0.05	MCL	15	n/a	-	0	-
Dibromomethane	UF	µg/L	97	0	0	n/a	n/a	n/a	n/a	0	na	60.83	Reg6	15	n/a	-	0	-
Dicamba	UF	µg/L	15	0	0	n/a	n/a	n/a	n/a	0	na	1095	Reg6	8	n/a	-	0	-
Dichlorobenzene[1,2-]	UF	µg/L	100	1	1	0.283	0.283	0.283	n/a	0	na	600	MCL	15	n/a	-	0	-
Dichlorobenzene[1,3-]	UF	µg/L	100	3	3	0.328	0.364	0.536	n/a	0	na	600	MCL	15	n/a	-	0	-
Dichlorobenzene[1,4-]	UF	µg/L	100	0	0	n/a	n/a	n/a	n/a	0	na	75	MCL	15	n/a	-	0	-
Dichlorobenzidine[3,3'-]	UF	µg/L	98	0	0	n/a	n/a	n/a	n/a	0	na	1.494	Reg6	15	n/a	-	0	-
Dichlorodifluoromethane	UF	µg/L	97	0	0	n/a	n/a	n/a	n/a	0	na	394.6	Reg6	15	n/a	-	0	-
Dichloroethane[1,1-]	UF	µg/L	97	0	0	n/a	n/a	n/a	n/a	0	na	25	NMGSU	15	n/a	-	0	-
Dichloroethane[1,2-]	UF	µg/L	97	0	0	n/a	n/a	n/a	n/a	0	na	5	MCL	15	n/a	-	0	-
Dichloroethene[1,1-]	UF	µg/L	97	0	0	n/a	n/a	n/a	n/a	0	na	5	NMGSU	15	n/a	-	0	-
Dichloroethene[cis-1,2-]	UF	µg/L	89	0	0	n/a	n/a	n/a	n/a	0	na	70	MCL	15	n/a	-	0	-
Dichloroethene[trans-1,2-]	UF	µg/L	97	0	0	n/a	n/a	n/a	n/a	0	na	100	MCL	15	n/a	-	0	-
Dichlorophenol[2,4-]	UF	µg/L	88	0	0	n/a	n/a	n/a	n/a	0	na	109.5	Reg6	15	n/a	-	0	-
Dichloropropane[1,2-]	UF	µg/L	97	0	0	n/a	n/a	n/a	n/a	0	na	5	MCL	15	n/a	-	0	-
Dichloropropane[1,3-]	UF	µg/L	97	0	0	n/a	n/a	n/a	n/a	n/a	na	na	na	15	n/a	-	n/a	-
Dichloropropane[2,2-]	UF	µg/L	97	0	0	n/a	n/a	n/a	n/a	n/a	na	na	na	15	n/a	-	n/a	-
Dichloropropene[1,1-]	UF	µg/L	97	0	0	n/a	n/a	n/a	n/a	n/a	na	na	na	15	n/a	-	n/a	-
Dichloropropene[cis-1,3-]	UF	µg/L	97	0	0	n/a	n/a	n/a	n/a	n/a	na	na	na	15	n/a	-	n/a	-
Dichloropropene[cis/trans-1,3-]	UF	µg/L	7	0	0	n/a	n/a	n/a	n/a	0	na	6.71	Reg6	7	n/a	-	0	-
Dichloropropene[trans-1,3-]	UF	µg/L	97	0	0	n/a	n/a	n/a	n/a	n/a	na	na	na	15	n/a	-	n/a	-
Dichlorprop	UF	µg/L	15	0	0	n/a	n/a	n/a	n/a	n/a	na	na	na	8	n/a	-	n/a	-
Dieldrin	UF	µg/L	87	1	1.15	0.00767	0.00767	0.00767	n/a	0	na	0.04202	Reg6	15	n/a	-	0	-
Diethyl Ether	UF	µg/L	41	0	0	n/a	n/a	n/a	n/a	n/a	na	na	na	13	n/a	-	n/a	-
Diethylphthalate	UF	µg/L	99	0	0	n/a	n/a	n/a	n/a	0	na	29200	Reg6	15	n/a	-	0	-

Table 6.3-15 (continued)

Constituent			Summary by Sample								Screening Values			Location Summary				
Organics	Field Prep	Units	Total	Detects (D)			Exceedances		GW Bkgd ^a	Screening Standard ^b		Locations with Data (Number)	D>Bkgd (Number of Locations)	D>Bkgd Station List ^c	D>Std (Number of Locations)	D>Std Station List ^c		
				Number	Rate (%)	Min.	Median	Max.		D>Bkgd (Number)	D>Std (Number)						Level	Level
Dimethyl Phthalate	UF	µg/L	99	0	0	n/a	n/a	n/a	n/a	0	na	365000	Reg6	15	n/a	-	0	-
Dimethylphenol[2,4-]	UF	µg/L	80	0	0	n/a	n/a	n/a	n/a	0	na	730	Reg6	15	n/a	-	0	-
Dinitro-2-methylphenol[4,6-]	UF	µg/L	89	0	0	n/a	n/a	n/a	n/a	n/a	na	na	na	15	n/a	-	n/a	-
Dinitrobenzene[1,3-]	UF	µg/L	99	0	0	n/a	n/a	n/a	n/a	0	na	3.65	Reg6	15	n/a	-	0	-
Dinitrophenol[2,4-]	UF	µg/L	89	0	0	n/a	n/a	n/a	n/a	0	na	73	Reg6	15	n/a	-	0	-
Dinitrotoluene[2,4-]	UF	µg/L	101	0	0	n/a	n/a	n/a	n/a	0	na	73	Reg6	15	n/a	-	0	-
Dinitrotoluene[2,6-]	UF	µg/L	101	0	0	n/a	n/a	n/a	n/a	0	na	36.5	Reg6	15	n/a	-	0	-
Dinoseb	UF	µg/L	82	0	0	n/a	n/a	n/a	n/a	0	na	7	MCL	15	n/a	-	0	-
Dioxane[1,4-]	UF	µg/L	81	0	0	n/a	n/a	n/a	n/a	0	na	61.12	Reg6	15	n/a	-	0	-
Diphenylamine	UF	µg/L	98	0	0	n/a	n/a	n/a	n/a	0	na	912.5	Reg6	15	n/a	-	0	-
Endosulfan I	UF	µg/L	87	0	0	n/a	n/a	n/a	n/a	n/a	na	na	na	15	n/a	-	n/a	-
Endosulfan II	UF	µg/L	87	1	1.15	0.00737	0.00737	0.00737	n/a	n/a	na	na	na	15	n/a	-	n/a	-
Endosulfan Sulfate	UF	µg/L	87	0	0	n/a	n/a	n/a	n/a	n/a	na	na	na	15	n/a	-	n/a	-
Endrin	UF	µg/L	87	1	1.15	0.00688	0.00688	0.00688	n/a	0	na	2	MCL	15	n/a	-	0	-
Endrin Aldehyde	UF	µg/L	87	0	0	n/a	n/a	n/a	n/a	n/a	na	na	na	15	n/a	-	n/a	-
Endrin Ketone	UF	µg/L	87	0	0	n/a	n/a	n/a	n/a	n/a	na	na	na	15	n/a	-	n/a	-
Ethyl Methacrylate	UF	µg/L	88	0	0	n/a	n/a	n/a	n/a	0	na	547.5	Reg6	15	n/a	-	0	-
Ethylbenzene	UF	µg/L	93	0	0	n/a	n/a	n/a	n/a	0	na	700	MCL	15	n/a	-	0	-
Fluoranthene	UF	µg/L	99	0	0	n/a	n/a	n/a	n/a	0	na	1460	Reg6	15	n/a	-	0	-
Fluorene	UF	µg/L	99	0	0	n/a	n/a	n/a	n/a	0	na	243.3	Reg6	15	n/a	-	0	-
HMX	UF	µg/L	99	15	15.2	0.148	1.36	7.66	n/a	0	na	1825	Reg6	15	n/a	-	0	-
Heptachlor	UF	µg/L	87	0	0	n/a	n/a	n/a	n/a	0	na	0.4	MCL	15	n/a	-	0	-
Heptachlor Epoxide	UF	µg/L	87	0	0	n/a	n/a	n/a	n/a	0	na	0.2	MCL	15	n/a	-	0	-
Heptachlorodibenzodioxin[1,2,3,4,6,7,8-]	UF	µg/L	4	0	0	n/a	n/a	n/a	n/a	n/a	na	na	na	2	n/a	-	n/a	-
Heptachlorodibenzodioxins [Total]	UF	µg/L	4	2	50	2.76E-06	5.41E-06	8.05E-06	n/a	n/a	na	na	na	2	n/a	-	n/a	-
Heptachlorodibenzofuran[1,2,3,4,6,7,8-]	UF	µg/L	3	0	0	n/a	n/a	n/a	n/a	n/a	na	na	na	2	n/a	-	n/a	-
Heptachlorodibenzofuran[1,2,3,4,7,8,9-]	UF	µg/L	4	0	0	n/a	n/a	n/a	n/a	n/a	na	na	na	2	n/a	-	n/a	-
Heptachlorodibenzofurans [Total]	UF	µg/L	4	1	25	5.25E-07	5.25E-07	5.25E-07	n/a	n/a	na	na	na	2	n/a	-	n/a	-
Hexachlorobenzene	UF	µg/L	99	0	0	n/a	n/a	n/a	n/a	0	na	1	MCL	15	n/a	-	0	-
Hexachlorobutadiene	UF	µg/L	100	0	0	n/a	n/a	n/a	n/a	0	na	8.619	Reg6	15	n/a	-	0	-
Hexachlorocyclopentadiene	UF	µg/L	99	0	0	n/a	n/a	n/a	n/a	0	na	50	MCL	15	n/a	-	0	-
Hexachlorodibenzodioxin[1,2,3,4,7,8-]	UF	µg/L	4	0	0	n/a	n/a	n/a	n/a	n/a	na	na	na	2	n/a	-	n/a	-
Hexachlorodibenzodioxin[1,2,3,6,7,8-]	UF	µg/L	4	0	0	n/a	n/a	n/a	n/a	n/a	na	na	na	2	n/a	-	n/a	-
Hexachlorodibenzodioxin[1,2,3,7,8,9-]	UF	µg/L	4	0	0	n/a	n/a	n/a	n/a	0	na	0.000108	Reg6	2	n/a	-	0	-
Hexachlorodibenzodioxins [Total]	UF	µg/L	4	0	0	n/a	n/a	n/a	n/a	n/a	na	na	na	2	n/a	-	n/a	-
Hexachlorodibenzofuran[1,2,3,4,7,8-]	UF	µg/L	4	0	0	n/a	n/a	n/a	n/a	n/a	na	na	na	2	n/a	-	n/a	-
Hexachlorodibenzofuran[1,2,3,6,7,8-]	UF	µg/L	4	0	0	n/a	n/a	n/a	n/a	n/a	na	na	na	2	n/a	-	n/a	-

Table 6.3-15 (continued)

Constituent			Summary by Sample								Screening Values			Location Summary				
Organics	Field Prep	Units	Total	Detects (D)			Exceedances		GW Bkgd ^a	Screening Standard ^b		Locations with Data (Number)	D>Bkgd (Number of Locations)	D>Bkgd Station List ^c	D>Std (Number of Locations)	D>Std Station List ^c		
				Number	Rate (%)	Min.	Median	Max.		D>Bkgd (Number)	D>Std (Number)						Level	Level
Hexachlorodibenzofuran[1,2,3,7,8,9-]	UF	µg/L	4	0	0	n/a	n/a	n/a	n/a	n/a	na	na	na	2	n/a	-	n/a	-
Hexachlorodibenzofuran[2,3,4,6,7,8-]	UF	µg/L	4	0	0	n/a	n/a	n/a	n/a	n/a	na	na	na	2	n/a	-	n/a	-
Hexachlorodibenzofurans [Total]	UF	µg/L	4	0	0	n/a	n/a	n/a	n/a	n/a	na	na	na	2	n/a	-	n/a	-
Hexachloroethane	UF	µg/L	99	0	0	n/a	n/a	n/a	n/a	0	na	48.02	Reg6	15	n/a	-	0	-
Hexanone[2-]	UF	µg/L	97	0	0	n/a	n/a	n/a	n/a	n/a	na	na	na	15	n/a	-	n/a	-
Indeno[1,2,3-cd]pyrene	UF	µg/L	99	1	1.01	2.67	2.67	2.67	n/a	1	na	0.295	Reg6	15	n/a	-	1	1
Iodomethane	UF	µg/L	97	0	0	n/a	n/a	n/a	n/a	n/a	na	na	na	15	n/a	-	n/a	-
Isobutyl alcohol	UF	µg/L	58	0	0	n/a	n/a	n/a	n/a	n/a	na	na	na	15	n/a	-	n/a	-
Isophorone	UF	µg/L	99	0	0	n/a	n/a	n/a	n/a	0	na	707.7	Reg6	15	n/a	-	0	-
Isopropylbenzene	UF	µg/L	97	0	0	n/a	n/a	n/a	n/a	0	na	658.2	Reg6	15	n/a	-	0	-
Isopropyltoluene[4-]	UF	µg/L	96	0	0	n/a	n/a	n/a	n/a	n/a	na	na	na	15	n/a	-	n/a	-
MCPA	UF	µg/L	15	0	0	n/a	n/a	n/a	n/a	0	na	18.25	Reg6	8	n/a	-	0	-
MCPP	UF	µg/L	15	0	0	n/a	n/a	n/a	n/a	0	na	36.5	Reg6	8	n/a	-	0	-
MNX	UF	µg/L	80	0	0	n/a	n/a	n/a	n/a	n/a	na	na	na	14	n/a	-	n/a	-
Methacrylonitrile	UF	µg/L	88	0	0	n/a	n/a	n/a	n/a	0	na	1.043	Reg6	15	n/a	-	0	-
Methoxychlor[4,4'-]	UF	µg/L	87	0	0	n/a	n/a	n/a	n/a	0	na	40	MCL	15	n/a	-	0	-
Methyl Methacrylate	UF	µg/L	88	0	0	n/a	n/a	n/a	n/a	0	na	1419.4	Reg6	15	n/a	-	0	-
Methyl tert-Butyl Ether	UF	µg/L	41	0	0	n/a	n/a	n/a	n/a	0	na	370.8	Reg6	13	n/a	-	0	-
Methyl-2-pentanone[4-]	UF	µg/L	97	0	0	n/a	n/a	n/a	n/a	0	na	1990.9	Reg6	15	n/a	-	0	-
Methylene Chloride	UF	µg/L	97	0	0	n/a	n/a	n/a	n/a	0	na	5	MCL	15	n/a	-	0	-
Methylnaphthalene[1-]	UF	µg/L	85	0	0	n/a	n/a	n/a	n/a	n/a	na	na	na	15	n/a	-	n/a	-
Methylnaphthalene[2-]	UF	µg/L	99	0	0	n/a	n/a	n/a	n/a	n/a	na	na	na	15	n/a	-	n/a	-
Methylphenol[2-]	UF	µg/L	89	0	0	n/a	n/a	n/a	n/a	0	na	1825	Reg6	15	n/a	-	0	-
Methylphenol[3,4-]	UF	µg/L	56	0	0	n/a	n/a	n/a	n/a	n/a	na	na	na	15	n/a	-	n/a	-
Methylphenol[4-]	UF	µg/L	33	0	0	n/a	n/a	n/a	n/a	0	na	182.5	Reg6	13	n/a	-	0	-
Methylpyridine[2-]	UF	µg/L	9	0	0	n/a	n/a	n/a	n/a	n/a	na	na	na	8	n/a	-	n/a	-
Naphthalene	UF	µg/L	100	0	0	n/a	n/a	n/a	n/a	0	na	30	NMGUSU	15	n/a	-	0	-
Nitroaniline[2-]	UF	µg/L	99	0	0	n/a	n/a	n/a	n/a	0	na	109.5	Reg6	15	n/a	-	0	-
Nitroaniline[3-]	UF	µg/L	99	0	0	n/a	n/a	n/a	n/a	n/a	na	na	na	15	n/a	-	n/a	-
Nitroaniline[4-]	UF	µg/L	99	0	0	n/a	n/a	n/a	n/a	n/a	na	na	na	15	n/a	-	n/a	-
Nitrobenzene	UF	µg/L	101	0	0	n/a	n/a	n/a	n/a	0	na	3.395	Reg6	15	n/a	-	0	-
Nitrophenol[2-]	UF	µg/L	82	0	0	n/a	n/a	n/a	n/a	n/a	na	na	na	15	n/a	-	n/a	-
Nitrophenol[4-]	UF	µg/L	89	0	0	n/a	n/a	n/a	n/a	0	na	292	Reg6	15	n/a	-	0	-
Nitroso-di-n-butylamine[N-]	UF	µg/L	90	0	0	n/a	n/a	n/a	n/a	0	na	0.1227	Reg6	15	n/a	-	0	-
Nitroso-di-n-propylamine[N-]	UF	µg/L	99	0	0	n/a	n/a	n/a	n/a	0	na	0.09604	Reg6	15	n/a	-	0	-
Nitrosodiethylamine[N-]	UF	µg/L	90	0	0	n/a	n/a	n/a	n/a	0	na	0.001436	Reg6	15	n/a	-	0	-
Nitrosodimethylamine[N-]	UF	µg/L	99	0	0	n/a	n/a	n/a	n/a	0	na	0.00422	Reg6	15	n/a	-	0	-

Table 6.3-15 (continued)

Constituent			Summary by Sample								Screening Values			Location Summary				
Organics	Field Prep	Units	Total	Detects (D)			Exceedances		GW Bkgd ^a	Screening Standard ^b		Locations with Data (Number)	D>Bkgd (Number of Locations)	D>Bkgd Station List ^c	D>Std (Number of Locations)	D>Std Station List ^c		
				Number	Rate (%)	Min.	Median	Max.		D>Bkgd (Number)	D>Std (Number)						Level	Level
Nitrosopyrrolidine[N-]	UF	µg/L	90	0	0	n/a	n/a	n/a	n/a	0	na	0.3202	Reg6	15	n/a	-	0	-
Nitrotoluene[2-]	UF	µg/L	99	0	0	n/a	n/a	n/a	n/a	0	na	2.923	Reg6	15	n/a	-	0	-
Nitrotoluene[3-]	UF	µg/L	99	0	0	n/a	n/a	n/a	n/a	0	na	121.7	Reg6	15	n/a	-	0	-
Nitrotoluene[4-]	UF	µg/L	99	0	0	n/a	n/a	n/a	n/a	0	na	39.55	Reg6	15	n/a	-	0	-
Octachlorodibenzodioxin[1,2,3,4,6,7,8,9-]	UF	µg/L	4	1	25	1.64E-05	1.64E-05	1.64E-05	n/a	n/a	na	na	na	2	n/a	-	n/a	-
Octachlorodibenzofuran[1,2,3,4,6,7,8,9-]	UF	µg/L	4	0	0	n/a	n/a	n/a	n/a	n/a	na	na	na	2	n/a	-	n/a	-
Oxybis[1-chloropropane][2,2'-]	UF	µg/L	99	0	0	n/a	n/a	n/a	n/a	0	na	9.536	Reg6	15	n/a	-	0	-
PETN	UF	µg/L	90	0	0	n/a	n/a	n/a	n/a	n/a	na	na	na	15	n/a	-	n/a	-
Pentachlorobenzene	UF	µg/L	90	0	0	n/a	n/a	n/a	n/a	0	na	29.2	Reg6	15	n/a	-	0	-
Pentachlorodibenzodioxin[1,2,3,7,8-]	UF	µg/L	4	0	0	n/a	n/a	n/a	n/a	n/a	na	na	na	2	n/a	-	n/a	-
Pentachlorodibenzodioxins [Total]	UF	µg/L	4	0	0	n/a	n/a	n/a	n/a	n/a	na	na	na	2	n/a	-	n/a	-
Pentachlorodibenzofuran[1,2,3,7,8-]	UF	µg/L	3	0	0	n/a	n/a	n/a	n/a	n/a	na	na	na	2	n/a	-	n/a	-
Pentachlorodibenzofuran[2,3,4,7,8-]	UF	µg/L	2	1	50	3.13E-06	3.13E-06	3.13E-06	n/a	n/a	na	na	na	2	n/a	-	n/a	-
Pentachlorodibenzofurans [Totals]	UF	µg/L	4	2	50	9.13E-07	3.14E-06	5.37E-06	n/a	n/a	na	na	na	2	n/a	-	n/a	-
Pentachlorophenol	UF	µg/L	89	0	0	n/a	n/a	n/a	n/a	0	na	1	MCL	15	n/a	-	0	-
Phenanthrene	UF	µg/L	93	0	0	n/a	n/a	n/a	n/a	n/a	na	na	na	15	n/a	-	n/a	-
Phenol	UF	µg/L	89	0	0	n/a	n/a	n/a	n/a	0	na	5	NMGSU	15	n/a	-	0	-
Propionitrile	UF	µg/L	74	0	0	n/a	n/a	n/a	n/a	n/a	na	na	na	15	n/a	-	n/a	-
Propylbenzene[1-]	UF	µg/L	95	0	0	n/a	n/a	n/a	n/a	0	na	60.83	Reg6	15	n/a	-	0	-
Pyrene	UF	µg/L	99	0	0	n/a	n/a	n/a	n/a	0	na	182.5	Reg6	15	n/a	-	0	-
Pyridine	UF	µg/L	52	0	0	n/a	n/a	n/a	n/a	0	na	36.5	Reg6	13	n/a	-	0	-
RDX	UF	µg/L	99	14	14.1	0.147	2.3	6.42	n/a	1	na	6.112	Reg6	15	n/a	-	1	2
Styrene	UF	µg/L	93	0	0	n/a	n/a	n/a	n/a	0	na	100	MCL	15	n/a	-	0	-
TATB	UF	µg/L	90	1	1.11	0.475	0.475	0.475	n/a	n/a	na	na	na	15	n/a	-	n/a	-
TNX	UF	µg/L	80	0	0	n/a	n/a	n/a	n/a	n/a	na	na	na	14	n/a	-	n/a	-
TP[2,4,5-]	UF	µg/L	15	0	0	n/a	n/a	n/a	n/a	0	na	50	MCL	8	n/a	-	0	-
T[2,4,5-]	UF	µg/L	15	0	0	n/a	n/a	n/a	n/a	0	na	365	Reg6	8	n/a	-	0	-
Tetrachlorobenzene[1,2,4,5]	UF	µg/L	90	0	0	n/a	n/a	n/a	n/a	n/a	na	na	na	15	n/a	-	n/a	-
Tetrachlorodibenzodioxin[2,3,7,8-]	UF	µg/L	4	0	0	n/a	n/a	n/a	n/a	0	na	0.00003	MCL	2	n/a	-	0	-
Tetrachlorodibenzodioxins [Total]	UF	µg/L	4	0	0	n/a	n/a	n/a	n/a	n/a	na	na	na	2	n/a	-	n/a	-
Tetrachlorodibenzofuran[2,3,7,8-]	UF	µg/L	4	1	25	5.90E-06	5.90E-06	5.90E-06	n/a	n/a	na	na	na	2	n/a	-	n/a	-
Tetrachlorodibenzofurans [Totals]	UF	µg/L	4	1	25	1.05E-05	1.05E-05	1.05E-05	n/a	n/a	na	na	na	2	n/a	-	n/a	-
Tetrachloroethane[1,1,1,2-]	UF	µg/L	97	0	0	n/a	n/a	n/a	n/a	0	na	25.5	Reg6	15	n/a	-	0	-
Tetrachloroethane[1,1,2,2-]	UF	µg/L	97	0	0	n/a	n/a	n/a	n/a	0	na	10	NMGSU	15	n/a	-	0	-
Tetrachloroethene	UF	µg/L	96	0	0	n/a	n/a	n/a	n/a	0	na	5	MCL	15	n/a	-	0	-
Tetrachlorophenol[2,3,4,6-]	UF	µg/L	80	0	0	n/a	n/a	n/a	n/a	0	na	5	MCL	15	n/a	-	0	-
Tetryl	UF	µg/L	99	0	0	n/a	n/a	n/a	n/a	0	na	146	Reg6	15	n/a	-	0	-

Table 6.3-15 (continued)

Constituent			Summary by Sample								Screening Values			Location Summary				
Organics	Field Prep	Units	Total	Detects (D)			Exceedances		GW Bkgd ^a	Screening Standard ^b		Locations with Data (Number)	D>Bkgd (Number of Locations)	D>Bkgd Station List ^c	D>Std (Number of Locations)	D>Std Station List ^c		
				Number	Rate (%)	Min.	Median	Max.		D>Bkgd (Number)	D>Std (Number)						Level	Level
Toluene	UF	µg/L	97	4	4.12	0.265	0.526	0.876	n/a	0	na	750	NMGSU	15	n/a	-	0	-
Toxaphene [Technical Grade]	UF	µg/L	87	0	0	n/a	n/a	n/a	n/a	0	na	3	MCL	15	n/a	-	0	-
Trichloro-1,2,2-trifluoroethane[1,1,2-]	UF	µg/L	97	0	0	n/a	n/a	n/a	n/a	0	na	59180	Reg6	15	n/a	-	0	-
Trichlorobenzene[1,2,3-]	UF	µg/L	87	0	0	n/a	n/a	n/a	n/a	n/a	na	na	na	15	n/a	-	n/a	-
Trichlorobenzene[1,2,4-]	UF	µg/L	100	0	0	n/a	n/a	n/a	n/a	0	na	70	MCL	15	n/a	-	0	-
Trichloroethane[1,1,1-]	UF	µg/L	97	0	0	n/a	n/a	n/a	n/a	0	na	60	NMGSU	15	n/a	-	0	-
Trichloroethane[1,1,2-]	UF	µg/L	97	0	0	n/a	n/a	n/a	n/a	0	na	5	MCL	15	n/a	-	0	-
Trichloroethene	UF	µg/L	97	1	1.03	0.351	0.351	0.351	n/a	0	na	5	MCL	15	n/a	-	0	-
Trichlorofluoromethane	UF	µg/L	97	0	0	n/a	n/a	n/a	n/a	0	na	5	MCL	15	n/a	-	0	-
Trichlorophenol[2,4,5-]	UF	µg/L	88	0	0	n/a	n/a	n/a	n/a	0	na	3650	Reg6	15	n/a	-	0	-
Trichlorophenol[2,4,6-]	UF	µg/L	87	0	0	n/a	n/a	n/a	n/a	0	na	61.12	Reg6	15	n/a	-	0	-
Trichloropropane[1,2,3-]	UF	µg/L	97	0	0	n/a	n/a	n/a	n/a	0	na	0.0947	Reg6	15	n/a	-	0	-
Trimethylbenzene[1,2,4-]	UF	µg/L	97	0	0	n/a	n/a	n/a	n/a	0	na	12.43	Reg6	15	n/a	-	0	-
Trimethylbenzene[1,3,5-]	UF	µg/L	96	0	0	n/a	n/a	n/a	n/a	0	na	12.33	Reg6	15	n/a	-	0	-
Trinitrobenzene[1,3,5-]	UF	µg/L	99	0	0	n/a	n/a	n/a	n/a	0	na	1095	Reg6	15	n/a	-	0	-
Trinitrotoluene[2,4,6-]	UF	µg/L	99	0	0	n/a	n/a	n/a	n/a	0	na	22.41	Reg6	15	n/a	-	0	-
Tris [o-cresyl] phosphate	UF	µg/L	82	0	0	n/a	n/a	n/a	n/a	n/a	na	na	na	15	n/a	-	n/a	-
Vinyl Chloride	UF	µg/L	97	0	0	n/a	n/a	n/a	n/a	0	na	1	NMGSU	15	n/a	-	0	-
Vinyl acetate	UF	µg/L	85	0	0	n/a	n/a	n/a	n/a	0	na	412.4	Reg6	15	n/a	-	0	-
Xylene [Total]	UF	µg/L	8	0	0	n/a	n/a	n/a	n/a	0	na	10000	MCL	8	n/a	-	0	-
Xylene[1,2-]	UF	µg/L	93	0	0	n/a	n/a	n/a	n/a	0	na	1431.4	Reg6	15	n/a	-	0	-
Xylene[1,3-]+Xylene[1,4-]	UF	µg/L	89	0	0	n/a	n/a	n/a	n/a	n/a	na	na	na	15	n/a	-	n/a	-

Notes: Light grey indicates exceeds groundwater background. Dark grey indicates exceeds standard.

^a Groundwater background UTL or maximum detect for Intermediate Groundwater filtered samples; LANL "Groundwater Background Investigation Report, Revision 3" (2007, 095817).

^b Screening Standard

Std Type	Standard (Source and Name)
NMGSF	NMAC 20.6.2, Groundwater Standards (Filtered)
NMGSU	NMAC 20.6.2, Groundwater Standards (Unfiltered)
NMRPS	NMEIB Radiation Protection Standards
MCL	EPA MCL
SMCL	EPA SMCL
Reg6	EPA Region 6 Tap Water Screening Level
DCG	DOE 4-mrem DCG

^c Station List (codes)

1 = Anderson Spring	9 = Spring 4AA
2 = Bulldog Spring	10 = Spring 4B
3 = Charlie's Spring	11 = Spring 4C
4 = Homestead Spring	12 = Starmer Spring
5 = Kieling Spring	13 = TA-18 Spring
6 = PC Spring	14 = TW-1.72 Spring
7 = Spring 4	15 = Threemile Spring
8 = Spring 4A	

^d n/a = Not applicable.
^e na = Not available (no published value).
^f - = None.

Table 6.3-16
Screening Table for Pajarito Watershed General Inorganics in Springs Groundwater

Constituent			Summary by Sample								Screening Values			Location Summary				
General Inorganics	Field Prep	Units	Total	Detects (D)					Exceedances		GW Bkgd ^a	Screening Standard ^b		Locations with Data (Number)	D>Bkgd (Number of Locations)	D>Bkgd Station List ^c	D>Std (Number of Locations)	D>Std Station List ^c
				Number	Rate (%)	Min.	Median	Max.	D>Bkgd (Number)	D>Std (Number)		Level	Level					
Alkalinity-CO ³	F	µg/L	104	3	2.88	740	1120	1200	n/a ^d	n/a	na ^e	na	na	15	n/a	- ^f	n/a	-
Alkalinity-CO ³ +HCO ³	F	µg/L	104	104	100	21400	54200	95800	55	n/a	52000	na	na	15	12	1, 2, 3, 5, 7, 8, 9, 10, 11, 12, 13, 14	n/a	-
Alkalinity-HCO ³	F	µg/L	11	11	100	34600	74200	87900	n/a	n/a	na	na	na	8	n/a	-	n/a	-
Ammonia as Nitrogen	F	µg/L	86	7	8.14	37.5	51.5	190	3	0	70	208.5714	Reg6	15	3	1, 2, 6	0	-
Bromide	F	µg/L	94	18	19.1	61	92	228	18	n/a	30	na	na	15	8	2, 3, 5, 7, 8, 9, 10, 11	n/a	-
Calcium	F	µg/L	102	102	100	6180	14800	26800	32	n/a	17310	na	na	15	7	2, 5, 7, 8, 9, 10, 11	n/a	-
Chloride	F	µg/L	105	105	100	917	7460	93500	50	0	7780	250000	NMGSF	15	10	1, 2, 3, 4, 5, 10, 12, 13, 14, 15	0	-
Cyanide [Total]	F	µg/L	41	7	17.1	1.66	3.48	12.3	n/a	n/a	na	na	na	12	n/a	-	n/a	-
Fluoride	F	µg/L	105	99	94.3	70	159	535	41	0	230	1600	NMGSF	15	8	1, 2, 7, 8, 9, 10, 11, 14	0	-
Hardness	F	µg/L	102	102	100	25700	55500	90100	n/a	n/a	na	na	na	15	n/a	-	n/a	-
Magnesium	F	µg/L	102	102	100	2500	4360	5720	0	n/a	6120	na	na	15	0	-	n/a	-
Nitrate-Nitrite as Nitrogen	F	µg/L	99	94	94.9	16	549	1660	0	0	2410	10000	NMGSF	15	0	-	0	-
Perchlorate	F	µg/L	94	87	92.6	0.0694	0.426	0.837	85	0	0.18	24.5	Reg6	15	13	1, 2, 3, 4, 5, 6, 7, 8, 9, 10, 11, 12, 15	0	-
Potassium	F	µg/L	102	102	100	1720	2720	4000	0	n/a	10030	na	na	15	0	-	n/a	-
Silicon Dioxide	F	µg/L	98	98	100	29900	42150	81700	36	n/a	50720	na	na	15	11	1, 2, 4, 5, 7, 8, 9, 10, 11, 12, 14	n/a	-
Sodium	F	µg/L	102	102	100	3580	12500	79800	57	n/a	12190	na	na	15	13	1, 2, 3, 5, 7, 8, 9, 10, 11, 12, 13, 14, 15	n/a	-
Specific Conductance	F	µS/cm	105	105	100	72.6	184	340	n/a	n/a	na	na	na	15	n/a	-	n/a	-
Sulfate	F	µg/L	105	105	100	2780	8870	37100	0	0	40030	600000	NMGSF	15	0	-	0	-
Total Dissolved Solids	F	µg/L	105	105	100	72000	153000	314000	74	0	127000	1000000	NMGSF	15	14	1, 2, 3, 4, 5, 7, 8, 9, 10, 11, 12, 13, 14, 15	0	-
Total Kjeldahl Nitrogen	F	µg/L	59	29	49.2	39	191	10700	13	n/a	200	na	na	15	12	1, 2, 3, 4, 5, 6, 8, 9, 10, 11, 12, 14	n/a	-
Total Phosphate as Phosphorus	F	µg/L	99	31	31.3	12	75	1090	15	n/a	80	na	na	15	8	1, 2, 3, 4, 5, 6, 10, 12	n/a	-
pH	F	SU	105	105	100	6.09	7.32	8.16	n/a	0	na	9	NMGSF	15	n/a	-	0	-
Alkalinity-CO ³	UF	µg/L	24	3	12.5	989	1070	3590	n/a	n/a	na	na	na	13	n/a	-	n/a	-
Alkalinity-CO ³ +HCO ³	UF	µg/L	24	24	100	33300	63100	95100	n/a	n/a	na	na	na	13	n/a	-	n/a	-
Alkalinity-HCO ³	UF	µg/L	3	3	100	77400	78300	94200	n/a	n/a	na	na	na	3	n/a	-	n/a	-
Ammonia as Nitrogen	UF	µg/L	20	3	15	52	86	174	n/a	0	na	208.5714	Reg6	13	n/a	-	0	-
Bromide	UF	µg/L	20	3	15	75	77	95	n/a	n/a	na	na	na	13	n/a	-	n/a	-
Calcium	UF	µg/L	94	94	100	6200	15100	27600	n/a	n/a	na	na	na	15	n/a	-	n/a	-
Chemical Oxygen Demand	UF	µg/L	7	7	100	14200	18400	20800	n/a	n/a	na	na	na	7	n/a	-	n/a	-

Table 6.3-16 (continued)

Constituent			Summary by Sample								Screening Values			Location Summary				
General Inorganics	Field Prep	Units	Total	Detects (D)			Exceedances		GW Bkgd ^a	Screening Standard ^b		Locations with Data (Number)	D>Bkgd (Number of Locations)	D>Bkgd Station List ^c	D>Std (Number of Locations)	D>Std Station List ^c		
				Number	Rate (%)	Min.	Median	Max.		D>Bkgd (Number)	D>Std (Number)						Level	Level
Chloride	UF	µg/L	23	23	100	1070	7730	28200	n/a	n/a	na	na	na	13	n/a	-	n/a	-
Cyanide [Total]	UF	µg/L	74	13	17.6	1.71	2.14	9.28	n/a	n/a	na	na	na	12	n/a	-	n/a	-
Fluoride	UF	µg/L	23	20	87	71	172.5	532	n/a	0	na	4000	MCL	13	n/a	-	0	-
Hardness	UF	µg/L	94	94	100	26000	57700	93900	n/a	n/a	na	na	na	15	n/a	-	n/a	-
Magnesium	UF	µg/L	94	94	100	2550	4545	6170	n/a	n/a	na	na	na	15	n/a	-	n/a	-
Nitrate-Nitrite as Nitrogen	UF	µg/L	23	23	100	53.8	409	1620	n/a	0	na	10000	MCL	13	n/a	-	0	-
Perchlorate	UF	µg/L	18	17	94.4	0.136	0.497	1.09	15	0	0.17	24.5	Reg6	11	9	2, 5, 6, 7, 8, 9, 10, 11, 13	0	-
Potassium	UF	µg/L	94	94	100	1680	2810	4380	n/a	n/a	na	na	na	15	n/a	-	n/a	-
Silicon Dioxide	UF	µg/L	33	33	100	31100	48600	85400	n/a	n/a	na	na	na	15	n/a	-	n/a	-
Sodium	UF	µg/L	94	94	100	3830	12650	81700	n/a	n/a	na	na	na	15	n/a	-	n/a	-
Specific Conductance	UF	µS/cm	23	23	100	79.1	200	247	0	n/a	276.03	na	na	13	0	-	n/a	-
Sulfate	UF	µg/L	23	23	100	3890	8080	10600	n/a	n/a	na	na	na	13	n/a	-	n/a	-
Suspended Sediment Concentration	UF	µg/L	79	46	58.2	1070	4600	95400	n/a	n/a	na	na	na	15	n/a	-	n/a	-
Total Kjeldahl Nitrogen	UF	µg/L	75	43	57.3	26	184	1140	n/a	n/a	na	na	na	15	n/a	-	n/a	-
Total Organic Carbon	UF	µg/L	75	72	96	384	3055	13900	n/a	n/a	na	na	na	15	n/a	-	n/a	-
Total Phosphate as Phosphorus	UF	µg/L	19	5	26.3	13	37	91	n/a	n/a	na	na	na	11	n/a	-	n/a	-
Total Suspended Solids	UF	µg/L	29	23	79.3	1000	5000	124000	n/a	n/a	na	na	na	13	n/a	-	n/a	-
pH	UF	SU	23	23	100	6.48	7.42	8.23	n/a	n/a	na	na	na	13	n/a	-	n/a	-

Notes: Light grey indicates exceeds groundwater background. Dark grey indicates exceeds standard.

^a Groundwater background UTL or maximum detect for intermediate groundwater filtered samples; LANL "Groundwater Background Investigation Report, Revision 3" (2007, 095817).

^b Screening Standard

Std Type	Standard (Source and Name)
NMGSF	NMAC 20.6.2, Groundwater Standards (Filtered)
NMGSU	NMAC 20.6.2, Groundwater Standards (Unfiltered)
NMRPS	NMEIB Radiation Protection Standards
MCL	EPA MCL
SMCL	EPA SMCL
Reg6	EPA Region 6 Tap Water Screening Level
DCG	DOE 4-mrem DCG

^c Station List (codes)

1 = Anderson Spring	9 = Spring 4AA
2 = Bulldog Spring	10 = Spring 4B
3 = Charlie's Spring	11 = Spring 4C
4 = Homestead Spring	12 = Starmer Spring
5 = Kieling Spring	13 = TA-18 Spring
6 = PC Spring	14 = TW-1.72 Spring
7 = Spring 4	15 = Threemile Spring
8 = Spring 4A	

^d n/a = Not applicable.
^e na = Not available (no published value).
^f - = None.

Table 6.3-17
Screening Table for Pajarito Watershed Metals in Surface Water (Base Flow and Springs)

Constituent			Summary by Sample							Screening Values			Location Summary					
Metals	Field Prep	Units	Total	Detects (D)			Exceedances		Wesl ^a Level	Screening Standard ^b		Locations with Data (Number)	D>wESL (Number of Locations)	D>wESL Station List ^c	D>Std (Number of Locations)	D>Std Station List ^c		
				Number	Rate (%)	Min.	Median	Max.		D>wESL (Number)	D>Std (Number)						Level	Std Type
Ephemeral and Intermittent																		
Aluminum	F	µg/L	131	98	74.8	27.5	835	12800	95	53	87	750	AqAcF	25	19	1, 2, 4, 5, 6, 9, 13, 14, 15, 16, 17, 19, 20, 21, 22, 25, 26, 29, 31	16	1, 2, 4, 5, 6, 13, 14, 15, 16, 17, 20, 22, 25, 26, 29, 31
Antimony	F	µg/L	135	2	1.48	1	2.95	4.9	0	0	100	640	HHEF	25	0	- ^d	0	-
Arsenic	F	µg/L	135	20	14.8	1.6	2.55	6.1	0	0	150	9	HHEF	25	0	-	0	-
Barium	F	µg/L	135	134	99.3	19.4	48.4	133	134	n/a ^e	3.8	na ^f	na	25	25	1, 2, 4, 5, 6, 7, 8, 9, 10, 11, 13, 14, 15, 16, 17, 18, 19, 20, 21, 22, 23, 25, 26, 29, 31	n/a	-
Beryllium	F	µg/L	135	1	0.741	0.191	0.191	0.191	0	n/a	5.3	na	na	25	0	-	n/a	-
Boron	F	µg/L	132	85	64.4	9.11	18.2	37.2	0	0	540	750	IrF	24	0	-	0	-
Cadmium	F	µg/L	135	8	5.93	0.041	0.115	0.14	0	0	0.15	2	AqAcF	25	0	-	0	-
Chromium	F	µg/L	135	58	43	1.1	3.1	9.3	0	0	77	100	IrF	25	0	-	0	-
Cobalt	F	µg/L	135	20	14.8	0.947	1.7	7.2	5	0	3	50	IrF	25	5	2, 10, 17, 22, 31	0	-
Copper	F	µg/L	99	15	15.2	1.5	3.4	5.8	2	0	5	13.4	AqAcF	25	2	5, 29	0	-
Iron	F	µg/L	135	105	77.8	14	410	6720	33	n/a	1000	na	na	25	11	1, 2, 4, 5, 13, 14, 17, 22, 26, 29, 31	n/a	-
Lead	F	µg/L	135	45	33.3	0.066	0.84	4	16	0	1.2	64.6	AqAcF	25	8	1, 2, 4, 5, 14, 17, 29, 31	0	-
Manganese	F	µg/L	135	84	62.2	0.91	8.55	302	7	n/a	80	na	na	25	3	13, 14, 19	n/a	-
Mercury	F	µg/L	119	4	3.36	0.038	0.0525	0.37	0	0	0.77	1.4	AqAcF	22	0	-	0	-
Molybdenum	F	µg/L	135	23	17	0.17	1.3	3.9	n/a	0	na	1000	IrF	25	n/a	-	0	-
Nickel	F	µg/L	135	94	69.6	0.5	1.3	4.1	0	0	28	467	AqAcF	25	0	-	0	-
Selenium	F	µg/L	122	4	3.28	1	2.1	2.9	0	0	5	50	LWF	25	0	-	0	-
Silicon Dioxide	F	µg/L	3	3	100	48700	50700	53300	n/a	n/a	na	na	na	3	n/a	-	n/a	-
Silver	F	µg/L	135	15	11.1	0.21	0.26	2.9	7	0	0.36	3.2	AqAcF	25	3	5, 17, 22	0	-
Strontium	F	µg/L	132	131	99.2	53.6	93.9	162	0	n/a	620	na	na	24	0	-	n/a	-
Thallium	F	µg/L	135	23	17	0.12	0.47	0.85	0	0	18	6.3	HHEF	25	0	-	0	-
Tin	F	µg/L	132	5	3.79	2.8	2.9	6.4	n/a	n/a	na	na	na	24	n/a	-	n/a	-
Uranium	F	µg/L	127	92	72.4	0.052	0.21	1.9	1	n/a	1.8	na	na	24	1	11	n/a	-
Vanadium	F	µg/L	135	103	76.3	1.1	4	12.7	0	0	19	100	IrF	25	0	-	0	-
Zinc	F	µg/L	132	63	47.7	2.1	4.9	21.5	0	0	66	117.2	AqAcF	25	0	-	0	-
Aluminum	UF	µg/L	130	115	88.5	72.1	1810	13900	110	n/a	87	na	na	27	23	1, 2, 4, 5, 6, 9, 10, 13, 14, 15, 16, 17, 18, 19, 20, 21, 22, 24, 25, 26, 28, 29, 31	n/a	-
Antimony	UF	µg/L	130	2	1.54	1.2	2.85	4.5	0	n/a	100	na	na	27	0	-	n/a	-
Arsenic	UF	µg/L	130	34	26.2	1.5	2.5	7.6	0	n/a	150	na	na	27	0	-	n/a	-
Barium	UF	µg/L	130	130	100	19.6	60.15	139	130	n/a	3.8	na	na	27	27	1, 2, 4, 5, 6, 7, 8, 9, 10, 11, 13, 14, 15, 16, 17, 18, 19, 20, 21, 22, 23, 24, 25, 26, 28, 29, 31	n/a	-

Table 6.3-17 (continued)

Constituent			Summary by Sample								Screening Values			Location Summary				
Metals	Field Prep	Units	Total	Detects (D)			Exceedances		Wesl ^a Level	Screening Standard ^b		Locations with Data (Number)	D>wESL (Number of Locations)	D>wESL Station List ^c	D>Std (Number of Locations)	D>Std Station List ^c		
				Number	Rate (%)	Min.	Median	Max.		D>wESL (Number)	D>Std (Number)						Level	Std Type
Beryllium	UF	µg/L	130	3	2.31	0.18	0.25	0.42	0	n/a	5.3	na	na	27	0	-	n/a	-
Boron	UF	µg/L	118	75	63.6	9.63	18.7	34.1	0	n/a	540	na	na	24	0	-	n/a	-
Cadmium	UF	µg/L	130	15	11.5	0.072	0.14	0.2	6	n/a	0.15	na	na	27	2	5, 26	n/a	-
Chromium	UF	µg/L	130	76	58.5	1.1	3.2	6.9	0	n/a	77	na	na	27	0	-	n/a	-
Cobalt	UF	µg/L	130	3	2.31	1.2	1.3	1.6	0	n/a	3	na	na	27	0	-	n/a	-
Copper	UF	µg/L	97	27	27.8	2.4	3.6	51.1	7	n/a	5	na	na	27	4	4, 5, 10, 26	n/a	-
Iron	UF	µg/L	130	121	93.1	25.3	926	6920	60	n/a	1000	na	na	27	20	1, 2, 4, 5, 6, 10, 13, 14, 15, 16, 17, 19, 20, 21, 22, 25, 26, 28, 29, 31	n/a	-
Lead	UF	µg/L	130	73	56.2	0.409	1.4	6	42	n/a	1.2	na	na	27	14	1, 2, 4, 5, 14, 16, 17, 20, 21, 22, 26, 28, 29, 31	n/a	-
Manganese	UF	µg/L	130	107	82.3	2	15	158	8	n/a	80	na	na	27	3	5, 13, 14	n/a	-
Mercury	UF	µg/L	141	6	4.26	0.047	0.069	0.87	1	0	0.77	10	WHU	27	1	10	0	-
Molybdenum	UF	µg/L	130	22	16.9	0.16	1.3	3.8	n/a	n/a	na	na	na	27	n/a	-	n/a	-
Nickel	UF	µg/L	130	102	78.5	0.55	1.5	6.3	0	n/a	28	na	na	27	0	-	n/a	-
Selenium	UF	µg/L	144	8	5.56	1.1	2.7	5.3	1	0	5	20	AqAcU	27	1	2	0	-
Silver	UF	µg/L	130	30	23.1	0.21	0.43	5.5	17	n/a	0.36	na	na	27	7	5, 17, 20, 21, 22, 25, 26	n/a	-
Strontium	UF	µg/L	118	118	100	54.3	93.8	167	0	n/a	620	na	na	24	0	-	n/a	-
Thallium	UF	µg/L	130	9	6.92	0.1	0.46	0.56	0	n/a	18	na	na	27	0	-	n/a	-
Tin	UF	µg/L	118	3	2.54	2.6	3	4	n/a	n/a	na	na	na	24	n/a	-	n/a	-
Uranium	UF	µg/L	118	88	74.6	0.052	0.299	2	2	n/a	1.8	na	na	24	1	11	n/a	-
Vanadium	UF	µg/L	130	109	83.8	0.96	5.5	13.9	0	n/a	19	na	na	27	0	-	n/a	-
Zinc	UF	µg/L	130	75	57.7	2.1	7.5	27.4	0	n/a	66	na	na	27	0	-	n/a	-
Perennial																		
Aluminum	F	µg/L	19	19	100	180	884	5730	19	19	87	87	AqChrF	3	3	3, 12, 27	3	3, 12, 27
Antimony	F	µg/L	19	0	0	n/a	n/a	n/a	0	0	100	640	HHPF	3	0	-	0	-
Arsenic	F	µg/L	19	2	10.5	1.6	1.8	2	0	0	150	9	HHPF	3	0	-	0	-
Barium	F	µg/L	19	19	100	33.7	47.5	70.2	19	n/a	3.8	na	na	3	3	3, 12, 27	n/a	-
Beryllium	F	µg/L	19	0	0	n/a	n/a	n/a	0	n/a	5.3	na	na	3	0	-	n/a	-
Boron	F	µg/L	19	11	57.9	10.2	14.1	24.7	0	0	540	750	IrF	3	0	-	0	-
Cadmium	F	µg/L	19	1	5.26	0.11	0.11	0.11	0	0	0.15	0.2	AqChrF	3	0	-	0	-
Chromium	F	µg/L	19	6	31.6	1.1	1.6	4.5	0	0	77	74.1	AqChrF	3	0	-	0	-
Cobalt	F	µg/L	19	4	21.1	1.3	1.7	2.2	0	0	3	50	IrF	3	0	-	0	-
Copper	F	µg/L	14	2	14.3	2.98	3.19	3.4	0	0	5	9	AqChrF	3	0	-	0	-
Iron	F	µg/L	19	19	100	67.9	346	2910	5	n/a	1000	na	na	3	2	3, 12	n/a	-
Lead	F	µg/L	19	8	42.1	0.17	0.985	1.7	3	0	1.2	2.5	AqChrF	3	1	12	0	-
Manganese	F	µg/L	19	12	63.2	2.4	6.015	18.8	0	n/a	80	na	na	3	0	-	n/a	-

Table 6.3-17 (continued)

Constituent			Summary by Sample								Screening Values			Location Summary					
Metals	Field Prep	Units	Total	Detects (D)			Exceedances		Wesl ^a Level	Screening Standard ^b		Locations with Data (Number)	D>wESL (Number of Locations)	D>wESL Station List ^c	D>Std (Number of Locations)	D>Std Station List ^c			
				Number	Rate (%)	Min.	Median	Max.		D>wESL (Number)	D>Std (Number)						Level	Std Type	
Mercury	F	µg/L	18	2	11.1	0.076	0.098	0.12	0	0	0.77	0.77	AqChrF	3	0	-	0	-	
Molybdenum	F	µg/L	19	2	10.5	0.32	0.325	0.33	n/a	0	na	1000	IrF	3	n/a	-	0	-	
Nickel	F	µg/L	19	16	84.2	0.65	0.965	2	0	0	28	52	AqChrF	3	0	-	0	-	
Selenium	F	µg/L	17	0	0	n/a	n/a	n/a	0	0	5	50	LWF	3	0	-	0	-	
Silver	F	µg/L	19	9	47.4	0.22	0.43	1.4	6	0	0.36	3.2	AqAcF	3	2	3, 12	0	-	
Strontium	F	µg/L	19	19	100	61.9	81.2	118	0	n/a	620	na	na	3	0	-	n/a	-	
Thallium	F	µg/L	19	2	10.5	0.59	0.59	0.59	0	0	18	6.3	HHPF	3	0	-	0	-	
Tin	F	µg/L	19	1	5.26	3.1	3.1	3.1	n/a	n/a	na	na	na	3	n/a	-	n/a	-	
Uranium	F	µg/L	18	12	66.7	0.063	0.1015	0.24	0	n/a	1.8	na	na	3	0	-	n/a	-	
Vanadium	F	µg/L	19	15	78.9	1.2	2.4	5.2	0	0	19	100	IrF	3	0	-	0	-	
Zinc	F	µg/L	18	8	44.4	2.3	4.4	51.5	0	0	66	117.2	AqAcF	3	0	-	0	-	
Aluminum	UF	µg/L	18	18	100	235	2935	12700	18	n/a	87	na	na	3	3	3, 12, 27	n/a	-	
Antimony	UF	µg/L	18	0	0	n/a	n/a	n/a	0	n/a	100	na	na	3	0	-	n/a	-	
Arsenic	UF	µg/L	18	4	22.2	1.9	2.2	3	0	n/a	150	na	na	3	0	-	n/a	-	
Barium	UF	µg/L	18	18	100	34.7	60	98.9	18	n/a	3.8	na	na	3	3	3, 12, 27	n/a	-	
Beryllium	UF	µg/L	18	1	5.56	0.39	0.39	0.39	0	n/a	5.3	na	na	3	0	-	n/a	-	
Boron	UF	µg/L	17	12	70.6	10.4	13.8	24.1	0	n/a	540	na	na	3	0	-	n/a	-	
Cadmium	UF	µg/L	18	2	11.1	0.13	0.14	0.15	0	n/a	0.15	na	na	3	0	-	n/a	-	
Chromium	UF	µg/L	18	9	50	1.9	3.6	6.2	0	n/a	77	na	na	3	0	-	n/a	-	
Cobalt	UF	µg/L	18	1	5.56	1.3	1.3	1.3	0	n/a	3	na	na	3	0	-	n/a	-	
Copper	UF	µg/L	13	4	30.8	3.1	3.75	4.2	0	n/a	5	na	na	3	0	-	n/a	-	
Iron	UF	µg/L	18	18	100	107	1392	6070	9	n/a	1000	na	na	3	3	3, 12, 27	n/a	-	
Lead	UF	µg/L	18	11	61.1	0.54	1.7	4.5	9	n/a	1.2	na	na	3	3	3, 12, 27	n/a	-	
Manganese	UF	µg/L	18	16	88.9	2.1	13.75	60.9	0	n/a	80	na	na	3	0	-	n/a	-	
Mercury	UF	µg/L	20	1	5	0.046	0.046	0.046	0	0	0.77	10	WHU	3	0	-	0	-	
Molybdenum	UF	µg/L	18	2	11.1	0.33	0.42	0.51	n/a	n/a	na	na	na	3	n/a	-	n/a	-	
Nickel	UF	µg/L	18	17	94.4	0.67	1.6	4.4	0	n/a	28	na	na	3	0	-	n/a	-	
Selenium	UF	µg/L	20	0	0	n/a	n/a	n/a	0	0	5	20	AqAcU	3	0	-	0	-	
Silver	UF	µg/L	18	15	83.3	0.27	0.69	6	12	n/a	0.36	na	na	3	3	3, 12, 27	n/a	-	
Strontium	UF	µg/L	17	17	100	61.9	86.8	120	0	n/a	620	na	na	3	0	-	n/a	-	
Thallium	UF	µg/L	18	0	0	n/a	n/a	n/a	0	n/a	18	na	na	3	0	-	n/a	-	

Table 6.3-17 (continued)

Constituent			Summary by Sample								Screening Values			Location Summary				
Metals	Field Prep	Units	Total	Detects (D)			Exceedances		Wesl ^a Level	Screening Standard ^b		Locations with Data (Number)	D>wESL (Number of Locations)	D>wESL Station List ^c	D>Std (Number of Locations)	D>Std Station List ^c		
				Number	Rate (%)	Min.	Median	Max.		D>wESL (Number)	D>Std (Number)						Level	Std Type
Tin	UF	µg/L	17	0	0	n/a	n/a	n/a	n/a	n/a	na	na	na	3	n/a	-	n/a	-
Uranium	UF	µg/L	17	12	70.6	0.072	0.265	0.45	0	n/a	1.8	na	na	3	0	-	n/a	-
Vanadium	UF	µg/L	18	17	94.4	1.6	3.9	11.1	0	n/a	19	na	na	3	0	-	n/a	-
Zinc	UF	µg/L	18	11	61.1	2.6	7.6	21.4	0	n/a	66	na	na	3	0	-	n/a	-

Notes: Light grey indicates exceeds groundwater background. Dark grey indicates exceeds standard.

^a Groundwater background UTL or maximum detect for intermediate groundwater filtered samples; LANL "Groundwater Background Investigation Report, Revision 3" (2007, 095817).

^d - = None.

^e n/a = Not applicable.

^b Screening Standard

^f na = Not available (no published value).

- AqChrU NMAC 20.6.4, Aquatic Life Chronic (Unfiltered) Hardness=100 mg/L
- HHEF NMAC 20.6.4, Human Health Ephemeral (Filtered)
- HHPF NMAC 20.6.4, Human Health Perennial (Filtered)
- HHEU NMAC 20.6.4, Human Health Ephemeral (Unfiltered)
- HHPU NMAC 20.6.4, Human Health Perennial (Unfiltered)
- IrF NMAC 20.6.4, Irrigation Standard (Filtered)
- LWF NMAC 20.6.4, Livestock Watering (Filtered)
- LWU NMAC 20.6.4, Livestock Watering (Unfiltered)
- WHU NMAC 20.6.4, Wildlife Habitat (Unfiltered)

^c Station List (codes)

- | | | |
|---------------------|-----------------------------------|--|
| 1=Anderson Spring | 11 = Spring 4 C | 21 = Pajarito above Twomile |
| 2=Bulldog Spring | 12 = Starmer Spring | 22 = Pajarito above Twomile |
| 3 Charlie's Spring | 13 = TA-18 Spring | 23 = Pajarito at Rio Grande |
| 4 = Homested Spring | 14 = TW-1.72 Spring | 24 = Pajarito below SR-501 |
| 5 = Kieling Spring | 15 = Threemile Spring | 25 = Pajaratio below TA-18 |
| 6 = PC Spring | 16 = La Delfe above Pajarito | 26 = Pajartio below confluences of South and North Anchor East Basin |
| 7 = Spring 4 | 17 = Pajartio 0.5 mi above SR-501 | 27 = Starmers above Pajartio |
| 8 = Spring 4A | 18 = Pajarito above SR-4 | 28 = Twomile Canyon below TA-59 |
| 9 = Spring 4AA | 19 = Pajarito above Starmers | 29 = Twomile below TA-59 |
| 10 = Spring 4B | 20 = Pajarito above TA-18 | 31 = Twomile above Pajatito |

Table 6.3-18
Screening Table for Pajarito Watershed Radionuclides in Surface Water (Base Flow and Springs)

Constituent			Summary by Sample							Screening Values			Location Summary					
Radionuclides	Field Prep	Units	Total	Detects (D)			Exceedances		wESL ^a	Screening Standard ^b		Locations with Data (Number)	D>wESL (Number of Locations)	D>wESL Station List ^c	D>Std (Number of Locations)	D>Std Station List ^c		
				Number	Rate (%)	Min.	Median	Max.	D>wESL (Number)	D>Std (Number)	Level						Level	Std Type
Ephemeral and Intermittent																		
Americium-241	F	pCi/L	109	0	0	n/a ^d	n/a	n/a	0	0	5.8	20	NMRPS	19	0	- ^e	0	-
Cesium-137	F	pCi/L	110	0	0	n/a	n/a	n/a	n/a	0	na ^f	40	BCG	19	n/a	-	0	-
Cobalt-60	F	pCi/L	109	0	0	n/a	n/a	n/a	0	0	380	3000	NMRPS	19	0	-	0	-
Gross alpha	F	pCi/L	82	10	12.2	0.986	1.81	5.78	n/a	n/a	na	na	na	19	n/a	-	n/a	-
Gross beta	F	pCi/L	82	57	69.5	1.43	3.67	12.8	n/a	n/a	na	na	na	19	n/a	-	n/a	-
Gross gamma	F	pCi/L	110	0	0	n/a	n/a	n/a	n/a	n/a	na	na	na	19	n/a	-	n/a	-
Neptunium-237	F	pCi/L	108	0	0	n/a	n/a	n/a	0	0	7.9	20	NMRPS	19	0	-	0	-
Plutonium-238	F	pCi/L	110	0	0	n/a	n/a	n/a	0	0	19	20	NMRPS	19	0	-	0	-
Plutonium-239/240	F	pCi/L	109	0	0	n/a	n/a	n/a	0	0	20	20	NMRPS	19	0	-	0	-
Potassium-40	F	pCi/L	103	3	2.91	24.8	36.3	49.1	n/a	0	na	4000	NMRPS	19	n/a	-	0	-
Radium-226	F	pCi/L	10	2	20	0.681	0.9955	1.31	2	0	0.1	60	NMRPS	7	2	2, 4	0	-
Sodium-22	F	pCi/L	109	0	0	n/a	n/a	n/a	0	0	90000	6000	NMRPS	19	0	-	0	-
Strontium-90	F	pCi/L	109	2	1.83	0.385	0.447	0.509	0	0	570	300	BCG	19	0	-	0	-
Thorium-228	F	pCi/L	3	0	0	n/a	n/a	n/a	0	n/a	5.9	na	na	2	0	-	n/a	-
Thorium-230	F	pCi/L	3	0	0	n/a	n/a	n/a	0	n/a	6.8	na	na	2	0	-	n/a	-
Thorium-232	F	pCi/L	3	0	0	n/a	n/a	n/a	0	0	0.81	300	BCG	2	0	-	0	-
Uranium-234	F	pCi/L	110	48	43.6	0.0383	0.181	1.13	0	0	22	200	BCG	19	0	-	0	-
Uranium-235/236	F	pCi/L	110	6	5.45	0.0308	0.053	0.094	0	0	24	300	NMRPS	19	0	-	0	-
Uranium-238	F	pCi/L	110	52	47.3	0.0426	0.1295	0.626	0	0	24	200	BCG	19	0	-	0	-
Americium-241	UF	pCi/L	115	0	0	n/a	n/a	n/a	0	0	5.8	20	NMRPS	24	0	-	0	-
Cesium-137	UF	pCi/L	113	0	0	n/a	n/a	n/a	n/a	0	na	40	BCG	24	n/a	-	0	-
Cobalt-60	UF	pCi/L	116	0	0	n/a	n/a	n/a	0	0	380	3000	NMRPS	24	0	-	0	-
Gross alpha	UF	pCi/L	88	27	30.7	0.739	2.94	5.21	n/a	n/a	na	na	na	24	n/a	-	n/a	-
Gross beta	UF	pCi/L	88	70	79.5	1.92	3.99	9.77	n/a	n/a	na	na	na	24	n/a	-	n/a	-
Gross gamma	UF	pCi/L	106	0	0	n/a	n/a	n/a	n/a	n/a	na	na	na	21	n/a	-	n/a	-
Lead-210	UF	pCi/L	4	0	0	n/a	n/a	n/a	0	n/a	250	na	na	4	0	-	n/a	-
Neptunium-237	UF	pCi/L	116	0	0	n/a	n/a	n/a	0	0	7.9	20	NMRPS	24	0	-	0	-
Plutonium-238	UF	pCi/L	116	1	0.862	0.199	0.199	0.199	0	0	19	20	NMRPS	24	0	-	0	-
Plutonium-239/240	UF	pCi/L	114	2	1.75	0.0518	0.1204	0.189	0	0	20	20	NMRPS	24	0	-	0	-
Polonium-210	UF	pCi/L	4	3	75	0.13	0.18	0.19	n/a	n/a	na	na	na	4	n/a	-	n/a	-
Potassium-40	UF	pCi/L	106	0	0	n/a	n/a	n/a	n/a	0	na	4000	NMRPS	23	n/a	-	0	-
Radium-226	UF	pCi/L	16	5	31.3	0.548	0.566	2.72	5	0	0.1	60	NMRPS	11	5	2, 4, 5, 6, 21	0	-
Radium-228	UF	pCi/L	11	4	36.4	0.584	2.605	3.13	4	0	0.09	60	NMRPS	9	4	4, 5, 22, 31	0	-
Sodium-22	UF	pCi/L	116	0	0	n/a	n/a	n/a	0	0	90000	6000	NMRPS	24	0	-	0	-

Table 6.3-18 (continued)

Constituent			Summary by Sample								Screening Values			Location Summary				
Radionuclides	Field Prep	Units	Total	Detects (D)			Exceedances		wESL ^a Level	Screening Standard ^b		Locations with Data (Number)	D>wESL (Number of Locations)	D>wESL Station List ^c	D>Std (Number of Locations)	D>Std Station List ^c		
				Number	Rate (%)	Min.	Median	Max.		D>Wesl (Number)	D>Std (Number)						Level	Std Type
Strontium-90	UF	pCi/L	116	7	6.03	0.162	0.437	0.745	0	0	570	300	BCG	24	0	-	0	-
Thorium-228	UF	pCi/L	8	1	12.5	0.16	0.16	0.16	0	n/a	5.9	na	na	6	0	-	n/a	-
Thorium-230	UF	pCi/L	8	0	0	n/a	n/a	n/a	0	n/a	6.8	na	na	6	0	-	n/a	-
Thorium-232	UF	pCi/L	8	3	37.5	0.0519	0.0544	0.309	0	0	0.81	300	BCG	6	0	-	0	-
Tritium	UF	pCi/L	121	90	74.4	0.9898	49.81	462	0	0	1.6E+08	1000000	NMRPS	24	0	-	0	-
Uranium-234	UF	pCi/L	116	71	61.2	0.0302	0.187	1.08	0	0	22	200	BCG	24	0	-	0	-
Uranium-235/236	UF	pCi/L	116	10	8.62	0.0319	0.05375	0.0753	0	0	24	300	NMRPS	24	0	-	0	-
Uranium-238	UF	pCi/L	116	75	64.7	0.0363	0.129	1.57	0	0	24	200	BCG	24	0	-	0	-
Perennial																		
Americium-241	F	pCi/L	18	0	0	n/a	n/a	n/a	0	0	5.8	20	NMRPS	3	0	-	0	-
Cesium-137	F	pCi/L	18	0	0	n/a	n/a	n/a	n/a	0	na	40	BCG	3	n/a	-	0	-
Cobalt-60	F	pCi/L	18	0	0	n/a	n/a	n/a	0	0	380	3000	NMRPS	3	0	-	0	-
Gross alpha	F	pCi/L	13	2	15.4	1.85	3.02	4.19	n/a	n/a	na	na	na	3	n/a	-	n/a	-
Gross beta	F	pCi/L	13	7	53.8	3.23	4.01	28.9	n/a	n/a	na	na	na	3	n/a	-	n/a	-
Gross gamma	F	pCi/L	18	0	0	n/a	n/a	n/a	n/a	n/a	na	na	na	3	n/a	-	n/a	-
Neptunium-237	F	pCi/L	17	0	0	n/a	n/a	n/a	0	0	7.9	20	NMRPS	3	0	-	0	-
Plutonium-238	F	pCi/L	18	0	0	n/a	n/a	n/a	0	0	19	20	NMRPS	3	0	-	0	-
Plutonium-239/240	F	pCi/L	17	1	5.88	0.855	0.855	0.855	0	0	20	20	NMRPS	3	0	-	0	-
Potassium-40	F	pCi/L	15	0	0	n/a	n/a	n/a	n/a	0	na	4000	NMRPS	2	n/a	-	0	-
Radium-226	F	pCi/L	1	1	100	1.28	1.28	1.28	1	0	0.1	60	NMRPS	1	1	12	0	-
Sodium-22	F	pCi/L	18	0	0	n/a	n/a	n/a	0	0	90000	6000	NMRPS	3	0	-	0	-
Strontium-90	F	pCi/L	18	0	0	n/a	n/a	n/a	0	0	570	300	BCG	3	0	-	0	-
Uranium-234	F	pCi/L	18	5	27.8	0.07	0.0783	0.113	0	0	22	200	BCG	3	0	-	0	-
Uranium-235/236	F	pCi/L	18	0	0	n/a	n/a	n/a	0	0	24	300	NMRPS	3	0	-	0	-
Uranium-238	F	pCi/L	18	3	16.7	0.0518	0.0605	0.0997	0	0	24	200	BCG	3	0	-	0	-
Americium-241	UF	pCi/L	18	0	0	n/a	n/a	n/a	0	0	5.8	20	NMRPS	3	0	-	0	-
Cesium-137	UF	pCi/L	17	0	0	n/a	n/a	n/a	n/a	0	na	40	BCG	3	n/a	-	0	-
Cobalt-60	UF	pCi/L	18	0	0	n/a	n/a	n/a	0	0	380	3000	NMRPS	3	0	-	0	-
Gross alpha	UF	pCi/L	13	5	38.5	3.04	3.22	5.86	n/a	n/a	na	na	na	3	n/a	-	n/a	-
Gross beta	UF	pCi/L	13	9	69.2	2	4.83	54.9	n/a	n/a	na	na	na	3	n/a	-	n/a	-
Gross gamma	UF	pCi/L	18	0	0	n/a	n/a	n/a	n/a	n/a	na	na	na	3	n/a	-	n/a	-
Neptunium-237	UF	pCi/L	18	0	0	n/a	n/a	n/a	0	0	7.9	20	NMRPS	3	0	-	0	-
Plutonium-238	UF	pCi/L	18	0	0	n/a	n/a	n/a	0	0	19	20	NMRPS	3	0	-	0	-
Plutonium-239/240	UF	pCi/L	17	0	0	n/a	n/a	n/a	0	0	20	20	NMRPS	3	0	-	0	-
Potassium-40	UF	pCi/L	17	0	0	n/a	n/a	n/a	n/a	0	na	4000	NMRPS	3	n/a	-	0	-
Radium-226	UF	pCi/L	2	1	50	1.16	1.16	1.16	1	0	0.1	60	NMRPS	2	1	12	0	-

Table 6.3-18 (continued)

Constituent			Summary by Sample								Screening Values			Location Summary				
Radionuclides	Field Prep	Units	Total	Detects (D)			Exceedances		wESL ^a	Screening Standard ^b		Locations with Data (Number)	D>wESL (Number of Locations)	D>wESL Station List ^c	D>Std (Number of Locations)	D>Std Station List ^c		
				Number	Rate (%)	Min.	Median	Max.	D>Wesl (Number)	D>Std (Number)	Level						Level	Std Type
Radium-228	UF	pCi/L	1	1	100	0.839	0.839	0.839	1	0	0.09	60	NMRPS	1	1	12	0	-
Sodium-22	UF	pCi/L	18	0	0	n/a	n/a	n/a	0	0	90000	6000	NMRPS	3	0	-	0	-
Strontium-90	UF	pCi/L	18	0	0	n/a	n/a	n/a	0	0	570	300	BCG	3	0	-	0	-
Thorium-228	UF	pCi/L	1	0	0	n/a	n/a	n/a	0	n/a	5.9	na	na	1	0	-	n/a	-
Thorium-230	UF	pCi/L	1	0	0	n/a	n/a	n/a	0	n/a	6.8	na	na	1	0	-	n/a	-
Thorium-232	UF	pCi/L	1	0	0	n/a	n/a	n/a	0	0	0.81	300	BCG	1	0	-	0	-
Tritium	UF	pCi/L	18	15	83.3	26.21	41.51	280	0	0	1.6E+08	1000000	NMRPS	3	0	-	0	-
Uranium-234	UF	pCi/L	18	12	66.7	0.0316	0.1235	0.165	0	0	22	200	BCG	3	0	-	0	-
Uranium-235/236	UF	pCi/L	18	0	0	n/a	n/a	n/a	0	0	24	300	NMRPS	3	0	-	0	-
Uranium-238	UF	pCi/L	18	10	55.6	0.0354	0.0752	0.121	0	0	24	200	BCG	3	0	-	0	-

Notes: Light grey indicates exceeds groundwater background. Dark grey indicates exceeds standard.

^a Groundwater background UTL or maximum detect for intermediate groundwater filtered samples; LANL "Groundwater Background Investigation Report, Revision 3" (2007, 095817).

^d n/a = Not applicable.

^e - = None.

^b Screening Standard

^f na = Not available (no published value).

- AqChrU NMAC 20.6.4, Aquatic Life Chronic (Unfiltered)
Hardness = 100 mg/L
- HHEF NMAC 20.6.4, Human Health Ephemeral (Filtered)
- HHPF NMAC 20.6.4, Human Health Perennial (Filtered)
- HHEU NMAC 20.6.4, Human Health Ephemeral (Unfiltered)
- HHPU NMAC 20.6.4, Human Health Perennial (Unfiltered)
- IrF NMAC 20.6.4, Irrigation Standard (Filtered)
- LWF NMAC 20.6.4, Livestock Watering (Filtered)
- LWU NMAC 20.6.4, Livestock Watering (Unfiltered)
- WHU NMAC 20.6.4, Wildlife Habitat (Unfiltered)

^c Station List (codes)

- | | | |
|----------------------|-----------------------------------|--|
| 1 = Anderson Spring | 11 = Spring 4 C | 21 = Pajarito above Twomile |
| 2 = Bulldog Spring | 12 = Starmer Spring | 22 = Pajarito above Twomile |
| 3 = Charlie's Spring | 13 = TA-18 Spring | 23 = Pajarito at Rio Grande |
| 4 = Homsted Spring | 14 = TW-1.72 Spring | 24 = Pajarito below SR-501 |
| 5 = Kieling Spring | 15 = Threemile Spring | 25 = Pajarito below TA-18 |
| 6 = PC Spring | 16 = La Delfe above Pajarito | 26 = Pajarito below confluences of South and North Anchor East Basin |
| 7 = Spring 4 | 17 = Pajarito 0.5 mi above SR-501 | 27 = Starmers above Pajarito |
| 8 = Spring 4A | 18 = Pajarito above SR-4 | 28 = Twomile Canyon below TA-59 |
| 9 = Spring 4AA | 19 = Pajarito above Starmers | 29 = Twomile below TA-59 |
| 10 = Spring 4B | 20 = Pajarito above TA-18 | 31 = Twomile above Pajarito |

Table 6.3-19
Screening Table for Pajarito Watershed Organics in Surface Water (Base Flow and Springs)

Constituent			Summary by Sample								Screening Values			Location Summary				
Organics	Field Prep	Units	Total	Detects (D)			Exceedances		wESL ^a	Screening Standard ^b		Locations with Data (Number)	D>wESL (Number of Locations)	D>wESL Station List ^c	D>Std (Number of Locations)	D>Std Station List ^c		
				Number	Rate (%)	Min.	Median	Max.	D>wESL (Number)	D>Std (Number)	Level						Level	Std Type
Ephemeral and Intermittent																		
2,4-Diamino-6-nitrotoluene	UF	µg/L	106	0	0	n/a ^d	n/a	n/a	n/a	n/a	na ^e	na	na	22	n/a	- ^f	n/a	-
2,6-Diamino-4-nitrotoluene	UF	µg/L	105	0	0	n/a	n/a	n/a	n/a	n/a	na	na	na	22	n/a	-	n/a	-
3,5-Dinitroaniline	UF	µg/L	106	0	0	n/a	n/a	n/a	n/a	n/a	na	na	na	22	n/a	-	n/a	-
Acenaphthene	UF	µg/L	124	0	0	n/a	n/a	n/a	0	n/a	23	na	na	21	0	-	n/a	-
Acenaphthylene	UF	µg/L	124	0	0	n/a	n/a	n/a	0	n/a	30	na	na	21	0	-	n/a	-
Acetone	UF	µg/L	116	27	23.3	1.32	2.58	15.6	0	n/a	11000	na	na	21	0	-	n/a	-
Acetonitrile	UF	µg/L	92	0	0	n/a	n/a	n/a	n/a	n/a	na	na	na	21	n/a	-	n/a	-
Acrolein	UF	µg/L	111	0	0	n/a	n/a	n/a	n/a	n/a	na	na	na	21	n/a	-	n/a	-
Acrylonitrile	UF	µg/L	123	0	0	n/a	n/a	n/a	n/a	n/a	na	na	na	21	n/a	-	n/a	-
Aldrin	UF	µg/L	106	0	0	n/a	n/a	n/a	n/a	0	na	0.0005	HHEU	19	n/a	-	0	-
Amino-2,6-dinitrotoluene[4-]	UF	µg/L	131	5	3.82	0.135	0.148	0.209	0	n/a	8600	na	na	26	0	-	n/a	-
Amino-4,6-dinitrotoluene[2-]	UF	µg/L	131	0	0	n/a	n/a	n/a	0	n/a	12000	na	na	26	0	-	n/a	-
Aniline	UF	µg/L	123	0	0	n/a	n/a	n/a	n/a	n/a	na	na	na	21	n/a	-	n/a	-
Anthracene	UF	µg/L	124	0	0	n/a	n/a	n/a	0	n/a	0.0013	na	na	21	0	-	n/a	-
Aroclor-1016	UF	µg/L	119	0	0	n/a	n/a	n/a	0	0	0.014	0.00064	HHEU	23	0	-	0	-
Aroclor-1221	UF	µg/L	119	0	0	n/a	n/a	n/a	n/a	0	na	0.00064	HHEU	23	n/a	-	0	-
Aroclor-1232	UF	µg/L	119	0	0	n/a	n/a	n/a	n/a	0	na	0.00064	HHEU	23	n/a	-	0	-
Aroclor-1242	UF	µg/L	119	0	0	n/a	n/a	n/a	0	0	0.06	0.00064	HHEU	23	0	-	0	-
Aroclor-1248	UF	µg/L	119	0	0	n/a	n/a	n/a	0	0	0.01	0.00064	HHEU	23	0	-	0	-
Aroclor-1254	UF	µg/L	119	0	0	n/a	n/a	n/a	0	0	0.02	0.00064	HHEU	23	0	-	0	-
Aroclor-1260	UF	µg/L	119	0	0	n/a	n/a	n/a	0	0	10	0.00064	HHEU	23	0	-	0	-
Aroclor-1262	UF	µg/L	114	0	0	n/a	n/a	n/a	n/a	0	na	0.00064	HHEU	22	n/a	-	0	-
Atrazine	UF	µg/L	93	0	0	n/a	n/a	n/a	n/a	n/a	na	na	na	21	n/a	-	n/a	-
Azobenzene	UF	µg/L	124	0	0	n/a	n/a	n/a	n/a	n/a	na	na	na	21	n/a	-	n/a	-
BHC[alpha-]	UF	µg/L	106	0	0	n/a	n/a	n/a	n/a	n/a	na	na	na	19	n/a	-	n/a	-
BHC[beta-]	UF	µg/L	106	0	0	n/a	n/a	n/a	0	n/a	2.4	na	na	19	0	-	n/a	-
BHC[delta-]	UF	µg/L	106	0	0	n/a	n/a	n/a	n/a	n/a	na	na	na	19	n/a	-	n/a	-
BHC[gamma-]	UF	µg/L	106	0	0	n/a	n/a	n/a	0	0	0.08	0.95	AqAcU	19	0	-	0	-
Benzene	UF	µg/L	118	0	0	n/a	n/a	n/a	0	n/a	45	na	na	21	0	-	n/a	-
Benzidine	UF	µg/L	83	0	0	n/a	n/a	n/a	n/a	n/a	na	na	na	21	n/a	-	n/a	-
Benzo[a]anthracene	UF	µg/L	124	0	0	n/a	n/a	n/a	0	n/a	0.027	na	na	21	0	-	n/a	-
Benzo[a]pyrene	UF	µg/L	124	1	0.806	0.34	0.34	0.34	1	1	0.014	0.18	HHEU	21	1	1	1	1
Benzo[b]fluoranthene	UF	µg/L	124	2	1.61	0.305	3.752	7.2	0	n/a	30	na	na	21	0	-	n/a	-
Benzo[g,h,i]perylene	UF	µg/L	124	1	0.806	0.636	0.636	0.636	0	n/a	30	na	na	21	0	-	n/a	-

Table 6.3-19 (continued)

Constituent			Summary by Sample								Screening Values			Location Summary				
Organics	Field Prep	Units	Total	Detects (D)					Exceedances		wESL ^a	Screening Standard ^b		Locations with Data (Number)	D>wESL (Number of Locations)	D>wESL Station List ^c	D>Std (Number of Locations)	D>Std Station List ^c
				Number	Rate (%)	Min.	Median	Max.	D>wESL (Number)	D>Std (Number)	Level	Level	Std Type					
Benzo[k]fluoranthene	UF	µg/L	124	2	1.61	0.322	0.411	0.5	0	n/a	30	na	na	21	0	-	n/a	-
Benzoic Acid	UF	µg/L	117	1	0.855	13.8	13.8	13.8	0	n/a	41	na	na	21	0	-	n/a	-
Benzyl Alcohol	UF	µg/L	124	0	0	n/a	n/a	n/a	n/a	n/a	na	na	na	21	n/a	-	n/a	-
Bis[2-chloroethoxy]methane	UF	µg/L	122	0	0	n/a	n/a	n/a	n/a	n/a	na	na	na	21	n/a	-	n/a	-
Bis[2-chloroethyl]ether	UF	µg/L	124	0	0	n/a	n/a	n/a	n/a	n/a	na	na	na	21	n/a	-	n/a	-
Bis[2-ethylhexyl]phthalate	UF	µg/L	124	5	4.03	2.13	2.51	2.74	0	n/a	32	na	na	21	0	-	n/a	-
Bromobenzene	UF	µg/L	119	0	0	n/a	n/a	n/a	n/a	n/a	na	na	na	21	n/a	-	n/a	-
Bromochloromethane	UF	µg/L	123	0	0	n/a	n/a	n/a	n/a	n/a	na	na	na	21	n/a	-	n/a	-
Bromodichloromethane	UF	µg/L	123	0	0	n/a	n/a	n/a	n/a	n/a	na	na	na	21	n/a	-	n/a	-
Bromoform	UF	µg/L	123	0	0	n/a	n/a	n/a	n/a	n/a	na	na	na	21	n/a	-	n/a	-
Bromomethane	UF	µg/L	123	0	0	n/a	n/a	n/a	n/a	n/a	na	na	na	21	n/a	-	n/a	-
Bromophenyl-phenylether[4-]	UF	µg/L	124	0	0	n/a	n/a	n/a	n/a	n/a	na	na	na	21	n/a	-	n/a	-
Butanol[1-]	UF	µg/L	25	0	0	n/a	n/a	n/a	n/a	n/a	na	na	na	11	n/a	-	n/a	-
Butanone[2-]	UF	µg/L	123	14	11.4	1.33	2.61	7.95	0	n/a	20000	na	na	21	0	-	n/a	-
Butylbenzene[n-]	UF	µg/L	123	0	0	n/a	n/a	n/a	n/a	n/a	na	na	na	21	n/a	-	n/a	-
Butylbenzene[sec-]	UF	µg/L	123	0	0	n/a	n/a	n/a	n/a	n/a	na	na	na	21	n/a	-	n/a	-
Butylbenzene[tert-]	UF	µg/L	123	0	0	n/a	n/a	n/a	n/a	n/a	na	na	na	21	n/a	-	n/a	-
Butylbenzylphthalate	UF	µg/L	124	0	0	n/a	n/a	n/a	0	n/a	22	na	na	21	0	-	n/a	-
Carbon Disulfide	UF	µg/L	118	0	0	n/a	n/a	n/a	n/a	n/a	na	na	na	21	n/a	-	n/a	-
Carbon Tetrachloride	UF	µg/L	123	0	0	n/a	n/a	n/a	n/a	n/a	na	na	na	21	n/a	-	n/a	-
Chlordane[alpha-]	UF	µg/L	106	0	0	n/a	n/a	n/a	0	0	0.0043	2.4	AqAcU	19	0	-	0	-
Chlordane[gamma-]	UF	µg/L	106	1	0.943	0.00564	0.00564	0.00564	1	n/a	0.0043	na	na	19	1	2	n/a	-
Chloro-1,3-butadiene[2-]	UF	µg/L	111	0	0	n/a	n/a	n/a	n/a	n/a	na	na	na	21	n/a	-	n/a	-
Chloro-1-propene[3-]	UF	µg/L	111	0	0	n/a	n/a	n/a	n/a	n/a	na	na	na	21	n/a	-	n/a	-
Chloro-3-methylphenol[4-]	UF	µg/L	117	0	0	n/a	n/a	n/a	n/a	n/a	na	na	na	21	n/a	-	n/a	-
Chloroaniline[4-]	UF	µg/L	124	0	0	n/a	n/a	n/a	n/a	n/a	na	na	na	21	n/a	-	n/a	-
Chlorobenzene	UF	µg/L	123	0	0	n/a	n/a	n/a	0	n/a	120	na	na	21	0	-	n/a	-
Chlorodibromomethane	UF	µg/L	123	0	0	n/a	n/a	n/a	n/a	n/a	na	na	na	21	n/a	-	n/a	-
Chloroethane	UF	µg/L	123	0	0	n/a	n/a	n/a	n/a	n/a	na	na	na	21	n/a	-	n/a	-
Chloroethyl vinyl ether[2-]	UF	µg/L	15	0	0	n/a	n/a	n/a	n/a	n/a	na	na	na	11	n/a	-	n/a	-
Chloroform	UF	µg/L	123	5	4.07	0.332	0.364	0.405	0	n/a	180	na	na	21	0	-	n/a	-
Chloromethane	UF	µg/L	119	0	0	n/a	n/a	n/a	n/a	n/a	na	na	na	21	n/a	-	n/a	-
Chloronaphthalene[2-]	UF	µg/L	124	0	0	n/a	n/a	n/a	n/a	n/a	na	na	na	21	n/a	-	n/a	-
Chlorophenol[2-]	UF	µg/L	117	1	0.855	0.43	0.43	0.43	0	n/a	43	na	na	21	0	-	n/a	-
Chlorophenyl-phenyl[4-] Ether	UF	µg/L	124	0	0	n/a	n/a	n/a	n/a	n/a	na	na	na	21	n/a	-	n/a	-
Chlorotoluene[2-]	UF	µg/L	116	0	0	n/a	n/a	n/a	n/a	n/a	na	na	na	21	n/a	-	n/a	-

Table 6.3-19 (continued)

Constituent			Summary by Sample								Screening Values			Location Summary				
Organics	Field Prep	Units	Total	Detects (D)					Exceedances		wESL ^a	Screening Standard ^b		Locations with Data (Number)	D>wESL (Number of Locations)	D>wESL Station List ^c	D>Std (Number of Locations)	D>Std Station List ^c
				Number	Rate (%)	Min.	Median	Max.	D>wESL (Number)	D>Std (Number)	Level	Level	Std Type					
Chlorotoluene[4-]	UF	µg/L	123	0	0	n/a	n/a	n/a	n/a	n/a	na	na	na	21	n/a	-	n/a	-
Chrysene	UF	µg/L	124	0	0	n/a	n/a	n/a	0	n/a	30	na	na	21	0	-	n/a	-
DB[2,4-]	UF	µg/L	20	0	0	n/a	n/a	n/a	n/a	n/a	na	na	na	11	n/a	-	n/a	-
DDD[4,4'-]	UF	µg/L	106	1	0.943	0.0233	0.0233	0.0233	n/a	1	na	0.0022	HHEU	19	n/a	-	1	2
DDE[4,4'-]	UF	µg/L	106	1	0.943	0.022	0.022	0.022	0	0	10	0.0022	HHEU	19	0	-	1	2
DDT[4,4'-]	UF	µg/L	106	1	0.943	0.0173	0.0173	0.0173	0	1	0.04	0.0022	HHEU	19	0	-	1	2
DNX	UF	µg/L	99	0	0	n/a	n/a	n/a	n/a	n/a	na	na	na	17	n/a	-	n/a	-
D[2,4-]	UF	µg/L	21	0	0	n/a	n/a	n/a	n/a	n/a	na	na	na	11	n/a	-	n/a	-
Dalapon	UF	µg/L	21	0	0	n/a	n/a	n/a	n/a	n/a	na	na	na	11	n/a	-	n/a	-
Di-n-butylphthalate	UF	µg/L	123	0	0	n/a	n/a	n/a	0	n/a	32	na	na	21	0	-	n/a	-
Di-n-octylphthalate	UF	µg/L	124	0	0	n/a	n/a	n/a	0	n/a	320	na	na	21	0	-	n/a	-
Dibenz[a,h]anthracene	UF	µg/L	124	1	0.806	3.16	3.16	3.16	0	n/a	30	na	na	21	0	-	n/a	-
Dibenzofuran	UF	µg/L	119	0	0	n/a	n/a	n/a	0	n/a	20	na	na	21	0	-	n/a	-
Dibromo-3-Chloropropane[1,2-]	UF	µg/L	123	0	0	n/a	n/a	n/a	n/a	n/a	na	na	na	21	n/a	-	n/a	-
Dibromoethane[1,2-]	UF	µg/L	123	0	0	n/a	n/a	n/a	n/a	n/a	na	na	na	21	n/a	-	n/a	-
Dibromomethane	UF	µg/L	123	0	0	n/a	n/a	n/a	n/a	n/a	na	na	na	21	n/a	-	n/a	-
Dicamba	UF	µg/L	21	0	0	n/a	n/a	n/a	n/a	n/a	na	na	na	11	n/a	-	n/a	-
Dichlorobenzene[1,2-]	UF	µg/L	125	0	0	n/a	n/a	n/a	n/a	n/a	na	na	na	21	n/a	-	n/a	-
Dichlorobenzene[1,3-]	UF	µg/L	125	3	2.4	0.328	0.364	0.536	n/a	n/a	na	na	na	21	n/a	-	n/a	-
Dichlorobenzene[1,4-]	UF	µg/L	125	0	0	n/a	n/a	n/a	0	n/a	15	na	na	21	0	-	n/a	-
Dichlorobenzidine[3,3'-]	UF	µg/L	123	0	0	n/a	n/a	n/a	n/a	n/a	na	na	na	21	n/a	-	n/a	-
Dichlorodifluoromethane	UF	µg/L	123	0	0	n/a	n/a	n/a	n/a	n/a	na	na	na	21	n/a	-	n/a	-
Dichloroethane[1,1-]	UF	µg/L	123	0	0	n/a	n/a	n/a	0	n/a	46	na	na	21	0	-	n/a	-
Dichloroethane[1,2-]	UF	µg/L	123	0	0	n/a	n/a	n/a	0	n/a	1100	na	na	21	0	-	n/a	-
Dichloroethene[1,1-]	UF	µg/L	123	0	0	n/a	n/a	n/a	0	n/a	190	na	na	21	0	-	n/a	-
Dichloroethene[cis-1,2-]	UF	µg/L	112	0	0	n/a	n/a	n/a	n/a	n/a	na	na	na	21	n/a	-	n/a	-
Dichloroethene[trans-1,2-]	UF	µg/L	123	0	0	n/a	n/a	n/a	n/a	n/a	na	na	na	21	n/a	-	n/a	-
Dichlorophenol[2,4-]	UF	µg/L	117	0	0	n/a	n/a	n/a	n/a	n/a	na	na	na	21	n/a	-	n/a	-
Dichloropropane[1,2-]	UF	µg/L	123	0	0	n/a	n/a	n/a	n/a	n/a	na	na	na	21	n/a	-	n/a	-
Dichloropropane[1,3-]	UF	µg/L	123	0	0	n/a	n/a	n/a	n/a	n/a	na	na	na	21	n/a	-	n/a	-
Dichloropropane[2,2-]	UF	µg/L	123	0	0	n/a	n/a	n/a	n/a	n/a	na	na	na	21	n/a	-	n/a	-
Dichloropropene[1,1-]	UF	µg/L	123	0	0	n/a	n/a	n/a	n/a	n/a	na	na	na	21	n/a	-	n/a	-
Dichloropropene[cis-1,3-]	UF	µg/L	123	0	0	n/a	n/a	n/a	n/a	n/a	na	na	na	21	n/a	-	n/a	-
Dichloropropene[cis/trans-1,3-]	UF	µg/L	10	0	0	n/a	n/a	n/a	n/a	n/a	na	na	na	10	n/a	-	n/a	-
Dichloropropene[trans-1,3-]	UF	µg/L	123	0	0	n/a	n/a	n/a	n/a	n/a	na	na	na	21	n/a	-	n/a	-
Dichlorprop	UF	µg/L	21	0	0	n/a	n/a	n/a	n/a	n/a	na	na	na	11	n/a	-	n/a	-

Table 6.3-19 (continued)

Constituent			Summary by Sample								Screening Values			Location Summary				
Organics	Field Prep	Units	Total	Detects (D)			Exceedances		wESL ^a	Screening Standard ^b		Locations with Data (Number)	D>wESL (Number of Locations)	D>wESL Station List ^c	D>Std (Number of Locations)	D>Std Station List ^c		
				Number	Rate (%)	Min.	Median	Max.	D>wESL (Number)	D>Std (Number)	Level						Level	Std Type
Dieldrin	UF	µg/L	106	1	0.943	0.00767	0.00767	0.00767	0	1	0.056	0.00054	HHEU	19	0	-	1	2
Diethyl Ether	UF	µg/L	54	0	0	n/a	n/a	n/a	n/a	n/a	na	na	na	16	n/a	-	n/a	-
Diethylphthalate	UF	µg/L	124	0	0	n/a	n/a	n/a	n/a	n/a	na	na	na	21	n/a	-	n/a	-
Dimethyl Phthalate	UF	µg/L	124	0	0	n/a	n/a	n/a	0	n/a	330	na	na	21	0	-	n/a	-
Dimethylphenol[2,4-]	UF	µg/L	109	0	0	n/a	n/a	n/a	n/a	n/a	na	na	na	21	n/a	-	n/a	-
Dinitro-2-methylphenol[4,6-]	UF	µg/L	116	0	0	n/a	n/a	n/a	n/a	n/a	na	na	na	21	n/a	-	n/a	-
Dinitrobenzene[1,3-]	UF	µg/L	131	0	0	n/a	n/a	n/a	0	n/a	26	na	na	26	0	-	n/a	-
Dinitrophenol[2,4-]	UF	µg/L	116	0	0	n/a	n/a	n/a	n/a	n/a	na	na	na	21	n/a	-	n/a	-
Dinitrotoluene[2,4-]	UF	µg/L	140	0	0	n/a	n/a	n/a	0	n/a	310	na	na	26	0	-	n/a	-
Dinitrotoluene[2,6-]	UF	µg/L	140	0	0	n/a	n/a	n/a	0	n/a	60	na	na	26	0	-	n/a	-
Dinoseb	UF	µg/L	106	0	0	n/a	n/a	n/a	n/a	n/a	na	na	na	20	n/a	-	n/a	-
Dioxane[1,4-]	UF	µg/L	99	0	0	n/a	n/a	n/a	n/a	n/a	na	na	na	19	n/a	-	n/a	-
Diphenylamine	UF	µg/L	123	0	0	n/a	n/a	n/a	n/a	n/a	na	na	na	21	n/a	-	n/a	-
Endosulfan I	UF	µg/L	106	0	0	n/a	n/a	n/a	0	0	0.056	0.22	AqAcU	19	0	-	0	-
Endosulfan II	UF	µg/L	106	1	0.943	0.00737	0.00737	0.00737	0	0	0.056	0.22	AqAcU	19	0	-	0	-
Endosulfan Sulfate	UF	µg/L	106	0	0	n/a	n/a	n/a	0	n/a	0.056	na	na	19	0	-	n/a	-
Endrin	UF	µg/L	106	1	0.943	0.00688	0.00688	0.00688	0	0	0.036	0.086	AqAcU	19	0	-	0	-
Endrin Aldehyde	UF	µg/L	106	1	0.943	0.00941	0.00941	0.00941	n/a	n/a	na	na	na	19	n/a	-	n/a	-
Endrin Ketone	UF	µg/L	106	0	0	n/a	n/a	n/a	n/a	n/a	na	na	na	19	n/a	-	n/a	-
Ethyl Methacrylate	UF	µg/L	111	0	0	n/a	n/a	n/a	n/a	n/a	na	na	na	21	n/a	-	n/a	-
Ethylbenzene	UF	µg/L	119	0	0	n/a	n/a	n/a	n/a	n/a	na	na	na	21	n/a	-	n/a	-
Fluoranthene	UF	µg/L	124	0	0	n/a	n/a	n/a	0	n/a	6.1	na	na	21	0	-	n/a	-
Fluorene	UF	µg/L	124	0	0	n/a	n/a	n/a	0	n/a	3.9	na	na	21	0	-	n/a	-
HMX	UF	µg/L	131	29	22.1	0.148	0.722	7.66	0	n/a	330000	na	na	26	0	-	n/a	-
Heptachlor	UF	µg/L	106	0	0	n/a	n/a	n/a	0	0	0.029	0.52	AqAcU	19	0	-	0	-
Heptachlor Epoxide	UF	µg/L	106	0	0	n/a	n/a	n/a	n/a	0	na	0.52	AqAcU	19	n/a	-	0	-
Heptachlorodibenzodioxin[1,2,3,4,6,7,8-]	UF	µg/L	8	0	0	n/a	n/a	n/a	n/a	n/a	na	na	na	4	n/a	-	n/a	-
Heptachlorodibenzodioxins [Total]	UF	µg/L	5	2	40	2.76E-06	5.41E-06	8.05E-06	n/a	n/a	na	na	na	3	n/a	-	n/a	-
Heptachlorodibenzofuran[1,2,3,4,6,7,8-]	UF	µg/L	7	0	0	n/a	n/a	n/a	n/a	n/a	na	na	na	4	n/a	-	n/a	-
Heptachlorodibenzofuran[1,2,3,4,7,8,9-]	UF	µg/L	8	0	0	n/a	n/a	n/a	n/a	n/a	na	na	na	4	n/a	-	n/a	-
Heptachlorodibenzofurans [Total]	UF	µg/L	5	1	20	5.25E-07	5.25E-07	5.25E-07	n/a	n/a	na	na	na	3	n/a	-	n/a	-
Hexachlorobenzene	UF	µg/L	124	0	0	n/a	n/a	n/a	n/a	0	na	0.0029	HHEU	21	n/a	-	0	-
Hexachlorobutadiene	UF	µg/L	125	0	0	n/a	n/a	n/a	n/a	n/a	na	na	na	21	n/a	-	n/a	-
Hexachlorocyclopentadiene	UF	µg/L	124	0	0	n/a	n/a	n/a	n/a	n/a	na	na	na	21	n/a	-	n/a	-
Hexachlorodibenzodioxin[1,2,3,4,7,8-]	UF	µg/L	8	0	0	n/a	n/a	n/a	n/a	n/a	na	na	na	4	n/a	-	n/a	-
Hexachlorodibenzodioxin[1,2,3,6,7,8-]	UF	µg/L	8	0	0	n/a	n/a	n/a	n/a	n/a	na	na	na	4	n/a	-	n/a	-

Table 6.3-19 (continued)

Constituent			Summary by Sample								Screening Values			Location Summary				
Organics	Field Prep	Units	Total	Detects (D)					Exceedances		wESL ^a	Screening Standard ^b		Locations with Data (Number)	D>wESL (Number of Locations)	D>wESL Station List ^c	D>Std (Number of Locations)	D>Std Station List ^c
				Number	Rate (%)	Min.	Median	Max.	D>wESL (Number)	D>Std (Number)	Level	Level	Std Type					
Hexachlorodibenzodioxin[1,2,3,7,8,9-]	UF	µg/L	8	0	0	n/a	n/a	n/a	n/a	n/a	na	na	na	4	n/a	-	n/a	-
Hexachlorodibenzodioxins [Total]	UF	µg/L	5	0	0	n/a	n/a	n/a	n/a	n/a	na	na	na	3	n/a	-	n/a	-
Hexachlorodibenzofuran[1,2,3,4,7,8-]	UF	µg/L	8	0	0	n/a	n/a	n/a	n/a	n/a	na	na	na	4	n/a	-	n/a	-
Hexachlorodibenzofuran[1,2,3,6,7,8-]	UF	µg/L	8	0	0	n/a	n/a	n/a	n/a	n/a	na	na	na	4	n/a	-	n/a	-
Hexachlorodibenzofuran[1,2,3,7,8,9-]	UF	µg/L	8	0	0	n/a	n/a	n/a	n/a	n/a	na	na	na	4	n/a	-	n/a	-
Hexachlorodibenzofuran[2,3,4,6,7,8-]	UF	µg/L	8	0	0	n/a	n/a	n/a	n/a	n/a	na	na	na	4	n/a	-	n/a	-
Hexachlorodibenzofurans [Total]	UF	µg/L	5	0	0	n/a	n/a	n/a	n/a	n/a	na	na	na	3	n/a	-	n/a	-
Hexachloroethane	UF	µg/L	124	0	0	n/a	n/a	n/a	n/a	n/a	na	na	na	21	n/a	-	n/a	-
Hexanone[2-]	UF	µg/L	123	0	0	n/a	n/a	n/a	n/a	n/a	na	na	na	21	n/a	-	n/a	-
Indeno[1,2,3-cd]pyrene	UF	µg/L	124	1	0.806	2.67	2.67	2.67	0	n/a	30	na	na	21	0	-	n/a	-
Iodomethane	UF	µg/L	123	0	0	n/a	n/a	n/a	n/a	n/a	na	na	na	21	n/a	-	n/a	-
Isobutyl alcohol	UF	µg/L	68	0	0	n/a	n/a	n/a	n/a	n/a	na	na	na	21	n/a	-	n/a	-
Isophorone	UF	µg/L	124	0	0	n/a	n/a	n/a	n/a	n/a	na	na	na	21	n/a	-	n/a	-
Isopropylbenzene	UF	µg/L	123	0	0	n/a	n/a	n/a	n/a	n/a	na	na	na	21	n/a	-	n/a	-
Isopropyltoluene[4-]	UF	µg/L	123	0	0	n/a	n/a	n/a	n/a	n/a	na	na	na	21	n/a	-	n/a	-
MCPA	UF	µg/L	21	0	0	n/a	n/a	n/a	n/a	n/a	na	na	na	11	n/a	-	n/a	-
MCPP	UF	µg/L	21	0	0	n/a	n/a	n/a	n/a	n/a	na	na	na	11	n/a	-	n/a	-
MX	UF	µg/L	99	0	0	n/a	n/a	n/a	n/a	n/a	na	na	na	17	n/a	-	n/a	-
Methacrylonitrile	UF	µg/L	111	0	0	n/a	n/a	n/a	n/a	n/a	na	na	na	21	n/a	-	n/a	-
Methoxychlor[4,4'-]	UF	µg/L	106	0	0	n/a	n/a	n/a	0	n/a	0.03	na	na	19	0	-	n/a	-
Methyl Methacrylate	UF	µg/L	111	0	0	n/a	n/a	n/a	n/a	n/a	na	na	na	21	n/a	-	n/a	-
Methyl tert-Butyl Ether	UF	µg/L	54	0	0	n/a	n/a	n/a	n/a	n/a	na	na	na	16	n/a	-	n/a	-
Methyl-2-pentanone[4-]	UF	µg/L	123	0	0	n/a	n/a	n/a	n/a	n/a	na	na	na	21	n/a	-	n/a	-
Methylene Chloride	UF	µg/L	123	0	0	n/a	n/a	n/a	0	n/a	2200	na	na	21	0	-	n/a	-
Methylnaphthalene[1-]	UF	µg/L	109	0	0	n/a	n/a	n/a	n/a	n/a	na	na	na	21	n/a	-	n/a	-
Methylnaphthalene[2-]	UF	µg/L	124	0	0	n/a	n/a	n/a	0	n/a	2	na	na	21	0	-	n/a	-
Methylphenol[2-]	UF	µg/L	117	0	0	n/a	n/a	n/a	n/a	n/a	na	na	na	21	n/a	-	n/a	-
Methylphenol[3-,4-]	UF	µg/L	73	0	0	n/a	n/a	n/a	n/a	n/a	na	na	na	20	n/a	-	n/a	-
Methylphenol[4-]	UF	µg/L	44	0	0	n/a	n/a	n/a	n/a	n/a	na	na	na	18	n/a	-	n/a	-
Methylpyridine[2-]	UF	µg/L	12	0	0	n/a	n/a	n/a	n/a	n/a	na	na	na	10	n/a	-	n/a	-
Naphthalene	UF	µg/L	125	1	0.8	0.28	0.28	0.28	0	n/a	23	na	na	21	0	-	n/a	-
Nitroaniline[2-]	UF	µg/L	124	0	0	n/a	n/a	n/a	n/a	n/a	na	na	na	21	n/a	-	n/a	-
Nitroaniline[3-]	UF	µg/L	124	0	0	n/a	n/a	n/a	n/a	n/a	na	na	na	21	n/a	-	n/a	-
Nitroaniline[4-]	UF	µg/L	124	0	0	n/a	n/a	n/a	n/a	n/a	na	na	na	21	n/a	-	n/a	-
Nitrobenzene	UF	µg/L	140	0	0	n/a	n/a	n/a	0	n/a	270	na	na	26	0	-	n/a	-
Nitrophenol[2-]	UF	µg/L	106	0	0	n/a	n/a	n/a	n/a	n/a	na	na	na	21	n/a	-	n/a	-

Table 6.3-19 (continued)

Constituent			Summary by Sample								Screening Values			Location Summary				
Organics	Field Prep	Units	Total	Detects (D)					Exceedances		wESL ^a	Screening Standard ^b		Locations with Data (Number)	D>wESL (Number of Locations)	D>wESL Station List ^c	D>Std (Number of Locations)	D>Std Station List ^c
				Number	Rate (%)	Min.	Median	Max.	D>wESL (Number)	D>Std (Number)	Level	Level	Std Type					
Nitrophenol[4-]	UF	µg/L	117	0	0	n/a	n/a	n/a	n/a	n/a	na	na	na	21	n/a	-	n/a	-
Nitroso-di-n-butylamine[N-]	UF	µg/L	112	0	0	n/a	n/a	n/a	n/a	n/a	na	na	na	21	n/a	-	n/a	-
Nitroso-di-n-propylamine[N-]	UF	µg/L	124	0	0	n/a	n/a	n/a	n/a	n/a	na	na	na	21	n/a	-	n/a	-
Nitrosodiethylamine[N-]	UF	µg/L	112	0	0	n/a	n/a	n/a	n/a	n/a	na	na	na	21	n/a	-	n/a	-
Nitrosodimethylamine[N-]	UF	µg/L	124	0	0	n/a	n/a	n/a	n/a	n/a	na	na	na	21	n/a	-	n/a	-
Nitrosopyrrolidine[N-]	UF	µg/L	112	0	0	n/a	n/a	n/a	n/a	n/a	na	na	na	21	n/a	-	n/a	-
Nitrotoluene[2-]	UF	µg/L	131	0	0	n/a	n/a	n/a	0	n/a	8000	na	na	26	0	-	n/a	-
Nitrotoluene[3-]	UF	µg/L	130	0	0	n/a	n/a	n/a	0	n/a	9600	na	na	26	0	-	n/a	-
Nitrotoluene[4-]	UF	µg/L	131	0	0	n/a	n/a	n/a	0	n/a	17000	na	na	26	0	-	n/a	-
Octachlorodibenzodioxin[1,2,3,4,6,7,8,9-]	UF	µg/L	8	2	25	3.97E-06	1.02E-05	1.64E-05	n/a	n/a	na	na	na	4	n/a	-	n/a	-
Octachlorodibenzofuran[1,2,3,4,6,7,8,9-]	UF	µg/L	8	0	0	n/a	n/a	n/a	n/a	n/a	na	na	na	4	n/a	-	n/a	-
Oxybis[1-chloropropane][2,2'-]	UF	µg/L	122	0	0	n/a	n/a	n/a	n/a	n/a	na	na	na	21	n/a	-	n/a	-
PETN	UF	µg/L	106	0	0	n/a	n/a	n/a	0	n/a	26000000	na	na	22	0	-	n/a	-
Pentachlorobenzene	UF	µg/L	112	0	0	n/a	n/a	n/a	n/a	n/a	na	na	na	21	n/a	-	n/a	-
Pentachlorodibenzodioxin[1,2,3,7,8-]	UF	µg/L	8	0	0	n/a	n/a	n/a	n/a	n/a	na	na	na	4	n/a	-	n/a	-
Pentachlorodibenzodioxins [Total]	UF	µg/L	5	0	0	n/a	n/a	n/a	n/a	n/a	na	na	na	3	n/a	-	n/a	-
Pentachlorodibenzofuran[1,2,3,7,8-]	UF	µg/L	7	0	0	n/a	n/a	n/a	n/a	n/a	na	na	na	4	n/a	-	n/a	-
Pentachlorodibenzofuran[2,3,4,7,8-]	UF	µg/L	6	1	16.7	3.13E-06	3.13E-06	3.13E-06	n/a	n/a	na	na	na	4	n/a	-	n/a	-
Pentachlorodibenzofurans [Totals]	UF	µg/L	5	2	40	9.13E-07	3.14E-06	5.37E-06	n/a	n/a	na	na	na	3	n/a	-	n/a	-
Pentachlorophenol	UF	µg/L	117	0	0	n/a	n/a	n/a	0	0	2.4	19	AqAcU	21	0	-	0	-
Phenanthrene	UF	µg/L	118	0	0	n/a	n/a	n/a	0	n/a	6.3	na	na	21	0	-	n/a	-
Phenol	UF	µg/L	117	0	0	n/a	n/a	n/a	0	n/a	110	na	na	21	0	-	n/a	-
Propionitrile	UF	µg/L	95	0	0	n/a	n/a	n/a	n/a	n/a	na	na	na	21	n/a	-	n/a	-
Propylbenzene[1-]	UF	µg/L	122	0	0	n/a	n/a	n/a	n/a	n/a	na	na	na	21	n/a	-	n/a	-
Pyrene	UF	µg/L	124	0	0	n/a	n/a	n/a	0	n/a	30	na	na	21	0	-	n/a	-
Pyridine	UF	µg/L	63	0	0	n/a	n/a	n/a	n/a	n/a	na	na	na	18	n/a	-	n/a	-
RDX	UF	µg/L	131	23	17.6	0.147	1.06	6.42	0	n/a	44000	na	na	26	0	-	n/a	-
Styrene	UF	µg/L	119	0	0	n/a	n/a	n/a	n/a	n/a	na	na	na	21	n/a	-	n/a	-
TATB	UF	µg/L	106	1	0.943	0.475	0.475	0.475	n/a	n/a	na	na	na	22	n/a	-	n/a	-
TNX	UF	µg/L	99	0	0	n/a	n/a	n/a	n/a	n/a	na	na	na	17	n/a	-	n/a	-
TP[2,4,5-]	UF	µg/L	21	0	0	n/a	n/a	n/a	n/a	n/a	na	na	na	11	n/a	-	n/a	-
T[2,4,5-]	UF	µg/L	21	0	0	n/a	n/a	n/a	n/a	n/a	na	na	na	11	n/a	-	n/a	-
Tetrachlorobenzene[1,2,4,5]	UF	µg/L	109	0	0	n/a	n/a	n/a	n/a	n/a	na	na	na	21	n/a	-	n/a	-
Tetrachlorodibenzodioxin[2,3,7,8-]	UF	µg/L	8	0	0	n/a	n/a	n/a	0	n/a	3.80E-06	na	na	4	0	-	n/a	-
Tetrachlorodibenzodioxins [Total]	UF	µg/L	5	0	0	n/a	n/a	n/a	n/a	n/a	na	na	na	3	n/a	-	n/a	-
Tetrachlorodibenzofuran[2,3,7,8-]	UF	µg/L	8	1	12.5	5.90E-06	5.90E-06	5.90E-06	n/a	n/a	na	na	na	4	n/a	-	n/a	-

Table 6.3-19 (continued)

Constituent			Summary by Sample								Screening Values			Location Summary				
Organics	Field Prep	Units	Total	Detects (D)					Exceedances		wESL ^a	Screening Standard ^b		Locations with Data (Number)	D>wESL (Number of Locations)	D>wESL Station List ^c	D>Std (Number of Locations)	D>Std Station List ^c
				Number	Rate (%)	Min.	Median	Max.	D>wESL (Number)	D>Std (Number)	Level	Level	Std Type					
Tetrachlorodibenzofurans [Totals]	UF	µg/L	5	1	20	1.05E-05	1.05E-05	1.05E-05	n/a	n/a	na	na	na	3	n/a	-	n/a	-
Tetrachloroethane[1,1,1,2-]	UF	µg/L	123	0	0	n/a	n/a	n/a	n/a	n/a	na	na	na	21	n/a	-	n/a	-
Tetrachloroethane[1,1,2,2-]	UF	µg/L	123	0	0	n/a	n/a	n/a	n/a	n/a	na	na	na	21	n/a	-	n/a	-
Tetrachloroethene	UF	µg/L	120	0	0	n/a	n/a	n/a	0	0	120	33	HHEU	21	0	-	0	-
Tetrachlorophenol[2,3,4,6-]	UF	µg/L	106	0	0	n/a	n/a	n/a	n/a	n/a	na	na	na	21	n/a	-	n/a	-
Tetryl	UF	µg/L	126	0	0	n/a	n/a	n/a	0	n/a	5800	na	na	25	0	-	n/a	-
Toluene	UF	µg/L	123	4	3.25	0.265	0.526	0.876	0	n/a	130	na	na	21	0	-	n/a	-
Toxaphene [Technical Grade]	UF	µg/L	106	0	0	n/a	n/a	n/a	0	0	0.0002	0.73	AqAcU	19	0	-	0	-
Trichloro-1,2,2-trifluoroethane[1,1,2-]	UF	µg/L	123	0	0	n/a	n/a	n/a	n/a	n/a	na	na	na	21	n/a	-	n/a	-
Trichlorobenzene[1,2,3-]	UF	µg/L	111	0	0	n/a	n/a	n/a	n/a	n/a	na	na	na	21	n/a	-	n/a	-
Trichlorobenzene[1,2,4-]	UF	µg/L	125	0	0	n/a	n/a	n/a	0	n/a	110	na	na	21	0	-	n/a	-
Trichloroethane[1,1,1-]	UF	µg/L	123	0	0	n/a	n/a	n/a	0	n/a	62	na	na	21	0	-	n/a	-
Trichloroethane[1,1,2-]	UF	µg/L	123	0	0	n/a	n/a	n/a	n/a	n/a	na	na	na	21	n/a	-	n/a	-
Trichloroethene	UF	µg/L	123	1	0.813	0.351	0.351	0.351	0	n/a	350	na	na	21	0	-	n/a	-
Trichlorofluoromethane	UF	µg/L	123	0	0	n/a	n/a	n/a	n/a	n/a	na	na	na	21	n/a	-	n/a	-
Trichlorophenol[2,4,5-]	UF	µg/L	117	0	0	n/a	n/a	n/a	n/a	n/a	na	na	na	21	n/a	-	n/a	-
Trichlorophenol[2,4,6-]	UF	µg/L	116	0	0	n/a	n/a	n/a	n/a	n/a	na	na	na	21	n/a	-	n/a	-
Trichloropropane[1,2,3-]	UF	µg/L	123	0	0	n/a	n/a	n/a	n/a	n/a	na	na	na	21	n/a	-	n/a	-
Trimethylbenzene[1,2,4-]	UF	µg/L	123	0	0	n/a	n/a	n/a	n/a	n/a	na	na	na	21	n/a	-	n/a	-
Trimethylbenzene[1,3,5-]	UF	µg/L	123	0	0	n/a	n/a	n/a	n/a	n/a	na	na	na	21	n/a	-	n/a	-
Trinitrobenzene[1,3,5-]	UF	µg/L	131	0	0	n/a	n/a	n/a	0	n/a	60000	na	na	26	0	-	n/a	-
Trinitrotoluene[2,4,6-]	UF	µg/L	131	0	0	n/a	n/a	n/a	0	n/a	40000	na	na	26	0	-	n/a	-
Tris [o-cresyl] phosphate	UF	µg/L	95	0	0	n/a	n/a	n/a	n/a	n/a	na	na	na	22	n/a	-	n/a	-
Vinyl Chloride	UF	µg/L	123	0	0	n/a	n/a	n/a	n/a	n/a	na	na	na	21	n/a	-	n/a	-
Vinyl acetate	UF	µg/L	108	0	0	n/a	n/a	n/a	n/a	n/a	na	na	na	21	n/a	-	n/a	-
Xylene [Total]	UF	µg/L	11	0	0	n/a	n/a	n/a	0	n/a	86	na	na	10	0	-	n/a	-
Xylene[1,2-]	UF	µg/L	119	0	0	n/a	n/a	n/a	n/a	n/a	na	na	na	21	n/a	-	n/a	-
Xylene[1,3-]+Xylene[1,4-]	UF	µg/L	116	0	0	n/a	n/a	n/a	n/a	n/a	na	na	na	21	n/a	-	n/a	-
Perennial																		
2,4-Diamino-6-nitrotoluene	UF	µg/L	17	0	0	n/a	n/a	n/a	n/a	n/a	na	na	na	3	n/a	-	n/a	-
2,6-Diamino-4-nitrotoluene	UF	µg/L	17	0	0	n/a	n/a	n/a	n/a	n/a	na	na	na	3	n/a	-	n/a	-
3,5-Dinitroaniline	UF	µg/L	17	0	0	n/a	n/a	n/a	n/a	n/a	na	na	na	3	n/a	-	n/a	-
Acenaphthene	UF	µg/L	17	0	0	n/a	n/a	n/a	0	0	23	990	HHPU	2	0	-	0	-
Acenaphthylene	UF	µg/L	17	0	0	n/a	n/a	n/a	0	n/a	30	na	na	2	0	-	n/a	-
Acetone	UF	µg/L	13	0	0	n/a	n/a	n/a	0	n/a	11000	na	na	2	0	-	n/a	-
Acetonitrile	UF	µg/L	12	0	0	n/a	n/a	n/a	n/a	n/a	na	na	na	2	n/a	-	n/a	-

Table 6.3-19 (continued)

Constituent			Summary by Sample								Screening Values			Location Summary				
Organics	Field Prep	Units	Total	Detects (D)					Exceedances		wESL ^a	Screening Standard ^b		Locations with Data (Number)	D>wESL (Number of Locations)	D>wESL Station List ^c	D>Std (Number of Locations)	D>Std Station List ^c
				Number	Rate (%)	Min.	Median	Max.	D>wESL (Number)	D>Std (Number)	Level	Level	Std Type					
Acrolein	UF	µg/L	14	0	0	n/a	n/a	n/a	n/a	0	na	290	HHPU	2	n/a	-	0	-
Acrylonitrile	UF	µg/L	16	0	0	n/a	n/a	n/a	n/a	0	na	2.5	HHPU	2	n/a	-	0	-
Aldrin	UF	µg/L	17	0	0	n/a	n/a	n/a	n/a	0	na	0.0005	HHPU	2	n/a	-	0	-
Amino-2,6-dinitrotoluene[4-]	UF	µg/L	19	0	0	n/a	n/a	n/a	0	n/a	8600	na	na	3	0	-	n/a	-
Amino-4,6-dinitrotoluene[2-]	UF	µg/L	19	0	0	n/a	n/a	n/a	0	n/a	12000	na	na	3	0	-	n/a	-
Aniline	UF	µg/L	17	0	0	n/a	n/a	n/a	n/a	n/a	na	na	na	2	n/a	-	n/a	-
Anthracene	UF	µg/L	17	0	0	n/a	n/a	n/a	0	0	0.0013	40000	HHPU	2	0	-	0	-
Aroclor-1016	UF	µg/L	17	0	0	n/a	n/a	n/a	0	0	0.014	0.00064	HHPU	2	0	-	0	-
Aroclor-1221	UF	µg/L	17	0	0	n/a	n/a	n/a	n/a	0	na	0.00064	HHPU	2	n/a	-	0	-
Aroclor-1232	UF	µg/L	17	0	0	n/a	n/a	n/a	n/a	0	na	0.00064	HHPU	2	n/a	-	0	-
Aroclor-1242	UF	µg/L	17	0	0	n/a	n/a	n/a	0	0	0.06	0.00064	HHPU	2	0	-	0	-
Aroclor-1248	UF	µg/L	17	0	0	n/a	n/a	n/a	0	0	0.01	0.00064	HHPU	2	0	-	0	-
Aroclor-1254	UF	µg/L	17	0	0	n/a	n/a	n/a	0	0	0.02	0.00064	HHPU	2	0	-	0	-
Aroclor-1260	UF	µg/L	17	0	0	n/a	n/a	n/a	0	0	10	0.00064	HHPU	2	0	-	0	-
Aroclor-1262	UF	µg/L	17	0	0	n/a	n/a	n/a	n/a	0	na	0.00064	HHPU	2	n/a	-	0	-
Atrazine	UF	µg/L	14	0	0	n/a	n/a	n/a	n/a	n/a	na	na	na	2	n/a	-	n/a	-
Azobenzene	UF	µg/L	17	0	0	n/a	n/a	n/a	n/a	n/a	na	na	na	2	n/a	-	n/a	-
BHC[alpha-]	UF	µg/L	17	0	0	n/a	n/a	n/a	n/a	0	na	0.049	HHPU	2	n/a	-	0	-
BHC[beta-]	UF	µg/L	17	0	0	n/a	n/a	n/a	0	0	2.4	0.17	HHPU	2	0	-	0	-
BHC[delta-]	UF	µg/L	17	0	0	n/a	n/a	n/a	n/a	n/a	na	na	na	2	n/a	-	n/a	-
BHC[gamma-]	UF	µg/L	17	0	0	n/a	n/a	n/a	0	0	0.08	0.63	HHPU	2	0	-	0	-
Benzene	UF	µg/L	14	0	0	n/a	n/a	n/a	0	0	45	510	HHPU	2	0	-	0	-
Benzidine	UF	µg/L	12	0	0	n/a	n/a	n/a	n/a	0	na	0.002	HHPU	2	n/a	-	0	-
Benzo[a]anthracene	UF	µg/L	17	0	0	n/a	n/a	n/a	0	0	0.027	0.18	HHPU	2	0	-	0	-
Benzo[a]pyrene	UF	µg/L	17	0	0	n/a	n/a	n/a	0	0	0.014	0.18	HHPU	2	0	-	0	-
Benzo[b]fluoranthene	UF	µg/L	17	0	0	n/a	n/a	n/a	0	0	30	0.18	HHPU	2	0	-	0	-
Benzo[g,h,i]perylene	UF	µg/L	17	0	0	n/a	n/a	n/a	0	n/a	30	na	na	2	0	-	n/a	-
Benzo[k]fluoranthene	UF	µg/L	17	0	0	n/a	n/a	n/a	0	0	30	0.18	HHPU	2	0	-	0	-
Benzoic Acid	UF	µg/L	13	0	0	n/a	n/a	n/a	0	n/a	41	na	na	2	0	-	n/a	-
Benzyl Alcohol	UF	µg/L	17	0	0	n/a	n/a	n/a	n/a	n/a	na	na	na	2	n/a	-	n/a	-
Bis[2-chloroethoxy]methane	UF	µg/L	16	0	0	n/a	n/a	n/a	n/a	n/a	na	na	na	2	n/a	-	n/a	-
Bis[2-chloroethyl]ether	UF	µg/L	17	0	0	n/a	n/a	n/a	n/a	0	na	5.3	HHPU	2	n/a	-	0	-
Bis[2-ethylhexyl]phthalate	UF	µg/L	17	0	0	n/a	n/a	n/a	0	0	32	22	HHPU	2	0	-	0	-
Bromobenzene	UF	µg/L	16	0	0	n/a	n/a	n/a	n/a	n/a	na	na	na	2	n/a	-	n/a	-
Bromochloromethane	UF	µg/L	16	0	0	n/a	n/a	n/a	n/a	n/a	na	na	na	2	n/a	-	n/a	-
Bromodichloromethane	UF	µg/L	16	0	0	n/a	n/a	n/a	n/a	0	na	170	HHPU	2	n/a	-	0	-

Table 6.3-19 (continued)

Constituent			Summary by Sample								Screening Values			Location Summary				
Organics	Field Prep	Units	Total	Detects (D)					Exceedances		wESL ^a	Screening Standard ^b		Locations with Data (Number)	D>wESL (Number of Locations)	D>wESL Station List ^c	D>Std (Number of Locations)	D>Std Station List ^c
				Number	Rate (%)	Min.	Median	Max.	D>wESL (Number)	D>Std (Number)	Level	Level	Std Type					
Bromoform	UF	µg/L	16	0	0	n/a	n/a	n/a	n/a	0	na	1400	HHPU	2	n/a	-	0	-
Bromomethane	UF	µg/L	16	0	0	n/a	n/a	n/a	n/a	0	na	1500	HHPU	2	n/a	-	0	-
Bromophenyl-phenylether[4-]	UF	µg/L	17	0	0	n/a	n/a	n/a	n/a	n/a	na	na	na	2	n/a	-	n/a	-
Butanol[1-]	UF	µg/L	4	0	0	n/a	n/a	n/a	n/a	n/a	na	na	na	2	n/a	-	n/a	-
Butanone[2-]	UF	µg/L	16	2	12.5	1.42	1.435	1.45	0	n/a	20000	na	na	2	0	-	n/a	-
Butylbenzene[n-]	UF	µg/L	15	0	0	n/a	n/a	n/a	n/a	n/a	na	na	na	2	n/a	-	n/a	-
Butylbenzene[sec-]	UF	µg/L	15	0	0	n/a	n/a	n/a	n/a	n/a	na	na	na	2	n/a	-	n/a	-
Butylbenzene[tert-]	UF	µg/L	15	0	0	n/a	n/a	n/a	n/a	n/a	na	na	na	2	n/a	-	n/a	-
Butylbenzylphthalate	UF	µg/L	17	0	0	n/a	n/a	n/a	0	0	22	1900	HHPU	2	0	-	0	-
Carbon Disulfide	UF	µg/L	16	0	0	n/a	n/a	n/a	n/a	n/a	na	na	na	2	n/a	-	n/a	-
Carbon Tetrachloride	UF	µg/L	16	0	0	n/a	n/a	n/a	n/a	0	na	16	HHPU	2	n/a	-	0	-
Chlordane[alpha-]	UF	µg/L	17	0	0	n/a	n/a	n/a	0	0	0.0043	0.0081	HHPU	2	0	-	0	-
Chlordane[gamma-]	UF	µg/L	17	0	0	n/a	n/a	n/a	0	0	0.0043	0.3	HHPU	2	0	-	0	-
Chloro-1,3-butadiene[2-]	UF	µg/L	15	0	0	n/a	n/a	n/a	n/a	n/a	na	na	na	2	n/a	-	n/a	-
Chloro-1-propene[3-]	UF	µg/L	15	0	0	n/a	n/a	n/a	n/a	n/a	na	na	na	2	n/a	-	n/a	-
Chloro-3-methylphenol[4-]	UF	µg/L	13	0	0	n/a	n/a	n/a	n/a	n/a	na	na	na	2	n/a	-	n/a	-
Chloroaniline[4-]	UF	µg/L	17	0	0	n/a	n/a	n/a	n/a	n/a	na	na	na	2	n/a	-	n/a	-
Chlorobenzene	UF	µg/L	16	0	0	n/a	n/a	n/a	0	0	120	21000	HHPU	2	0	-	0	-
Chlorodibromomethane	UF	µg/L	16	0	0	n/a	n/a	n/a	n/a	0	na	130	HHPU	2	n/a	-	0	-
Chloroethane	UF	µg/L	16	0	0	n/a	n/a	n/a	n/a	n/a	na	na	na	2	n/a	-	n/a	-
Chloroethyl vinyl ether[2-]	UF	µg/L	3	0	0	n/a	n/a	n/a	n/a	n/a	na	na	na	2	n/a	-	n/a	-
Chloroform	UF	µg/L	16	0	0	n/a	n/a	n/a	0	0	180	4700	HHPU	2	0	-	0	-
Chloromethane	UF	µg/L	15	0	0	n/a	n/a	n/a	n/a	n/a	na	na	na	2	n/a	-	n/a	-
Chloronaphthalene[2-]	UF	µg/L	17	0	0	n/a	n/a	n/a	n/a	0	na	1600	HHPU	2	n/a	-	0	-
Chlorophenol[2-]	UF	µg/L	13	0	0	n/a	n/a	n/a	0	0	43	150	HHPU	2	0	-	0	-
Chlorophenyl-phenyl[4-] Ether	UF	µg/L	17	0	0	n/a	n/a	n/a	n/a	n/a	na	na	na	2	n/a	-	n/a	-
Chlorotoluene[2-]	UF	µg/L	16	0	0	n/a	n/a	n/a	n/a	n/a	na	na	na	2	n/a	-	n/a	-
Chlorotoluene[4-]	UF	µg/L	16	0	0	n/a	n/a	n/a	n/a	n/a	na	na	na	2	n/a	-	n/a	-
Chrysene	UF	µg/L	17	0	0	n/a	n/a	n/a	0	0	30	0.18	HHPU	2	0	-	0	-
DB[2,4-]	UF	µg/L	3	0	0	n/a	n/a	n/a	n/a	n/a	na	na	na	2	n/a	-	n/a	-
DDD[4,4'-]	UF	µg/L	17	0	0	n/a	n/a	n/a	n/a	0	na	0.0022	HHPU	2	n/a	-	0	-
DDE[4,4'-]	UF	µg/L	17	0	0	n/a	n/a	n/a	0	0	10	0.0022	HHPU	2	0	-	0	-
DDT[4,4'-]	UF	µg/L	17	0	0	n/a	n/a	n/a	0	0	0.04	0.0022	HHPU	2	0	-	0	-
DNX	UF	µg/L	15	0	0	n/a	n/a	n/a	n/a	n/a	na	na	na	2	n/a	-	n/a	-
D[2,4-]	UF	µg/L	4	0	0	n/a	n/a	n/a	n/a	n/a	na	na	na	2	n/a	-	n/a	-
Dalapon	UF	µg/L	4	0	0	n/a	n/a	n/a	n/a	n/a	na	na	na	2	n/a	-	n/a	-

Table 6.3-19 (continued)

Constituent			Summary by Sample								Screening Values			Location Summary				
Organics	Field Prep	Units	Total	Detects (D)					Exceedances		wESL ^a	Screening Standard ^b		Locations with Data (Number)	D>wESL (Number of Locations)	D>wESL Station List ^c	D>Std (Number of Locations)	D>Std Station List ^c
				Number	Rate (%)	Min.	Median	Max.	D>wESL (Number)	D>Std (Number)	Level	Level	Std Type					
Di-n-butylphthalate	UF	µg/L	17	0	0	n/a	n/a	n/a	0	0	32	4500	HHPU	2	0	-	0	-
Di-n-octylphthalate	UF	µg/L	17	0	0	n/a	n/a	n/a	0	n/a	320	na	na	2	0	-	n/a	-
Dibenz[a,h]anthracene	UF	µg/L	17	0	0	n/a	n/a	n/a	0	0	30	0.18	HHPU	2	0	-	0	-
Dibenzofuran	UF	µg/L	17	0	0	n/a	n/a	n/a	0	n/a	20	na	na	2	0	-	n/a	-
Dibromo-3-Chloropropane[1,2-]	UF	µg/L	16	0	0	n/a	n/a	n/a	n/a	n/a	na	na	na	2	n/a	-	n/a	-
Dibromoethane[1,2-]	UF	µg/L	16	0	0	n/a	n/a	n/a	n/a	n/a	na	na	na	2	n/a	-	n/a	-
Dibromomethane	UF	µg/L	16	0	0	n/a	n/a	n/a	n/a	n/a	na	na	na	2	n/a	-	n/a	-
Dicamba	UF	µg/L	4	0	0	n/a	n/a	n/a	n/a	n/a	na	na	na	2	n/a	-	n/a	-
Dichlorobenzene[1,2-]	UF	µg/L	17	1	5.88	0.283	0.283	0.283	n/a	0	na	17000	HHPU	2	n/a	-	0	-
Dichlorobenzene[1,3-]	UF	µg/L	17	0	0	n/a	n/a	n/a	n/a	0	na	960	HHPU	2	n/a	-	0	-
Dichlorobenzene[1,4-]	UF	µg/L	17	0	0	n/a	n/a	n/a	0	0	15	2600	HHPU	2	0	-	0	-
Dichlorobenzidine[3,3'-]	UF	µg/L	17	0	0	n/a	n/a	n/a	n/a	0	na	0.28	HHPU	2	n/a	-	0	-
Dichlorodifluoromethane	UF	µg/L	16	0	0	n/a	n/a	n/a	n/a	n/a	na	na	na	2	n/a	-	n/a	-
Dichloroethane[1,1-]	UF	µg/L	16	0	0	n/a	n/a	n/a	0	n/a	46	na	na	2	0	-	n/a	-
Dichloroethane[1,2-]	UF	µg/L	16	0	0	n/a	n/a	n/a	0	0	1100	370	HHPU	2	0	-	0	-
Dichloroethene[1,1-]	UF	µg/L	16	0	0	n/a	n/a	n/a	0	0	190	32	HHPU	2	0	-	0	-
Dichloroethene[cis-1,2-]	UF	µg/L	15	0	0	n/a	n/a	n/a	n/a	n/a	na	na	na	2	n/a	-	n/a	-
Dichloroethene[trans-1,2-]	UF	µg/L	16	0	0	n/a	n/a	n/a	n/a	0	na	140000	HHPU	2	n/a	-	0	-
Dichlorophenol[2,4-]	UF	µg/L	12	0	0	n/a	n/a	n/a	n/a	0	na	290	HHPU	2	n/a	-	0	-
Dichloropropane[1,2-]	UF	µg/L	16	0	0	n/a	n/a	n/a	n/a	0	na	150	HHPU	2	n/a	-	0	-
Dichloropropane[1,3-]	UF	µg/L	16	0	0	n/a	n/a	n/a	n/a	n/a	na	na	na	2	n/a	-	n/a	-
Dichloropropane[2,2-]	UF	µg/L	16	0	0	n/a	n/a	n/a	n/a	n/a	na	na	na	2	n/a	-	n/a	-
Dichloropropene[1,1-]	UF	µg/L	16	0	0	n/a	n/a	n/a	n/a	n/a	na	na	na	2	n/a	-	n/a	-
Dichloropropene[cis-1,3-]	UF	µg/L	16	0	0	n/a	n/a	n/a	n/a	n/a	na	na	na	2	n/a	-	n/a	-
Dichloropropene[cis/trans-1,3-]	UF	µg/L	2	0	0	n/a	n/a	n/a	n/a	0	na	1700	HHPU	2	n/a	-	0	-
Dichloropropene[trans-1,3-]	UF	µg/L	16	0	0	n/a	n/a	n/a	n/a	n/a	na	na	na	2	n/a	-	n/a	-
Dichlorprop	UF	µg/L	4	0	0	n/a	n/a	n/a	n/a	n/a	na	na	na	2	n/a	-	n/a	-
Dieldrin	UF	µg/L	17	0	0	n/a	n/a	n/a	0	0	0.056	0.00054	HHPU	2	0	-	0	-
Diethyl Ether	UF	µg/L	9	0	0	n/a	n/a	n/a	n/a	n/a	na	na	na	2	n/a	-	n/a	-
Diethylphthalate	UF	µg/L	17	0	0	n/a	n/a	n/a	n/a	0	na	44000	HHPU	2	n/a	-	0	-
Dimethyl Phthalate	UF	µg/L	17	0	0	n/a	n/a	n/a	0	0	330	1100000	HHPU	2	0	-	0	-
Dimethylphenol[2,4-]	UF	µg/L	11	0	0	n/a	n/a	n/a	n/a	0	na	850	HHPU	2	n/a	-	0	-
Dinitro-2-methylphenol[4,6-]	UF	µg/L	13	0	0	n/a	n/a	n/a	n/a	0	na	280	HHPU	2	n/a	-	0	-
Dinitrobenzene[1,3-]	UF	µg/L	19	0	0	n/a	n/a	n/a	0	n/a	26	na	na	3	0	-	n/a	-
Dinitrophenol[2,4-]	UF	µg/L	13	0	0	n/a	n/a	n/a	n/a	0	na	5300	HHPU	2	n/a	-	0	-
Dinitrotoluene[2,4-]	UF	µg/L	19	0	0	n/a	n/a	n/a	0	0	310	34	HHPU	3	0	-	0	-

Table 6.3-19 (continued)

Constituent			Summary by Sample								Screening Values			Location Summary				
Organics	Field Prep	Units	Total	Detects (D)					Exceedances		wESL ^a	Screening Standard ^b		Locations with Data (Number)	D>wESL (Number of Locations)	D>wESL Station List ^c	D>Std (Number of Locations)	D>Std Station List ^c
				Number	Rate (%)	Min.	Median	Max.	D>wESL (Number)	D>Std (Number)	Level	Level	Std Type					
Dinitrotoluene[2,6-]	UF	µg/L	19	0	0	n/a	n/a	n/a	0	n/a	60	na	na	3	0	-	n/a	-
Dinoseb	UF	µg/L	13	0	0	n/a	n/a	n/a	n/a	n/a	na	na	na	2	n/a	-	n/a	-
Dioxane[1,4-]	UF	µg/L	15	0	0	n/a	n/a	n/a	n/a	n/a	na	na	na	2	n/a	-	n/a	-
Diphenylamine	UF	µg/L	17	0	0	n/a	n/a	n/a	n/a	n/a	na	na	na	2	n/a	-	n/a	-
Endosulfan I	UF	µg/L	17	0	0	n/a	n/a	n/a	0	0	0.056	0.22	AqAcU	2	0	-	0	-
Endosulfan II	UF	µg/L	17	0	0	n/a	n/a	n/a	0	0	0.056	0.22	AqAcU	2	0	-	0	-
Endosulfan Sulfate	UF	µg/L	17	0	0	n/a	n/a	n/a	0	0	0.056	89	HHPU	2	0	-	0	-
Endrin	UF	µg/L	17	0	0	n/a	n/a	n/a	0	0	0.036	0.086	AqAcU	2	0	-	0	-
Endrin Aldehyde	UF	µg/L	17	0	0	n/a	n/a	n/a	n/a	n/a	na	na	na	2	n/a	-	n/a	-
Endrin Ketone	UF	µg/L	17	0	0	n/a	n/a	n/a	n/a	n/a	na	na	na	2	n/a	-	n/a	-
Ethyl Methacrylate	UF	µg/L	15	0	0	n/a	n/a	n/a	n/a	n/a	na	na	na	2	n/a	-	n/a	-
Ethylbenzene	UF	µg/L	16	0	0	n/a	n/a	n/a	n/a	0	na	29000	HHPU	2	n/a	-	0	-
Fluoranthene	UF	µg/L	17	0	0	n/a	n/a	n/a	0	0	6.1	140	HHPU	2	0	-	0	-
Fluorene	UF	µg/L	17	0	0	n/a	n/a	n/a	0	0	3.9	5300	HHPU	2	0	-	0	-
HMX	UF	µg/L	19	0	0	n/a	n/a	n/a	0	n/a	330000	na	na	3	0	-	n/a	-
Heptachlor	UF	µg/L	17	0	0	n/a	n/a	n/a	0	0	0.029	0.00079	HHPU	2	0	-	0	-
Heptachlor Epoxide	UF	µg/L	17	0	0	n/a	n/a	n/a	n/a	0	na	0.00039	HHPU	2	n/a	-	0	-
Hexachlorobenzene	UF	µg/L	17	0	0	n/a	n/a	n/a	n/a	0	na	0.0029	HHPU	2	n/a	-	0	-
Hexachlorobutadiene	UF	µg/L	17	0	0	n/a	n/a	n/a	n/a	0	na	180	HHPU	2	n/a	-	0	-
Hexachlorocyclopentadiene	UF	µg/L	17	0	0	n/a	n/a	n/a	n/a	0	na	17000	HHPU	2	n/a	-	0	-
Hexachloroethane	UF	µg/L	17	0	0	n/a	n/a	n/a	n/a	0	na	33	HHPU	2	n/a	-	0	-
Hexanone[2-]	UF	µg/L	16	0	0	n/a	n/a	n/a	n/a	n/a	na	na	na	2	n/a	-	n/a	-
Indeno[1,2,3-cd]pyrene	UF	µg/L	17	0	0	n/a	n/a	n/a	0	0	30	0.18	HHPU	2	0	-	0	-
Iodomethane	UF	µg/L	16	0	0	n/a	n/a	n/a	n/a	n/a	na	na	na	2	n/a	-	n/a	-
Isobutyl alcohol	UF	µg/L	11	0	0	n/a	n/a	n/a	n/a	n/a	na	na	na	2	n/a	-	n/a	-
Isophorone	UF	µg/L	17	0	0	n/a	n/a	n/a	n/a	0	na	9600	HHPU	2	n/a	-	0	-
Isopropylbenzene	UF	µg/L	16	0	0	n/a	n/a	n/a	n/a	n/a	na	na	na	2	n/a	-	n/a	-
Isopropyltoluene[4-]	UF	µg/L	15	0	0	n/a	n/a	n/a	n/a	n/a	na	na	na	2	n/a	-	n/a	-
MCPA	UF	µg/L	4	0	0	n/a	n/a	n/a	n/a	n/a	na	na	na	2	n/a	-	n/a	-
MCPP	UF	µg/L	4	0	0	n/a	n/a	n/a	n/a	n/a	na	na	na	2	n/a	-	n/a	-
MNX	UF	µg/L	15	0	0	n/a	n/a	n/a	n/a	n/a	na	na	na	2	n/a	-	n/a	-
Methacrylonitrile	UF	µg/L	15	0	0	n/a	n/a	n/a	n/a	n/a	na	na	na	2	n/a	-	n/a	-
Methoxychlor[4,4'-]	UF	µg/L	17	0	0	n/a	n/a	n/a	0	n/a	0.03	na	na	2	0	-	n/a	-
Methyl Methacrylate	UF	µg/L	15	0	0	n/a	n/a	n/a	n/a	n/a	na	na	na	2	n/a	-	n/a	-
Methyl tert-Butyl Ether	UF	µg/L	9	0	0	n/a	n/a	n/a	n/a	n/a	na	na	na	2	n/a	-	n/a	-
Methyl-2-pentanone[4-]	UF	µg/L	16	0	0	n/a	n/a	n/a	n/a	n/a	na	na	na	2	n/a	-	n/a	-

Table 6.3-19 (continued)

Constituent			Summary by Sample								Screening Values			Location Summary				
Organics	Field Prep	Units	Total	Detects (D)					Exceedances		wESL ^a	Screening Standard ^b		Locations with Data (Number)	D>wESL (Number of Locations)	D>wESL Station List ^c	D>Std (Number of Locations)	D>Std Station List ^c
				Number	Rate (%)	Min.	Median	Max.	D>wESL (Number)	D>Std (Number)	Level	Level	Std Type					
Methylene Chloride	UF	µg/L	16	0	0	n/a	n/a	n/a	0	0	2200	5900	HHPU	2	0	-	0	-
Methylnaphthalene[1-]	UF	µg/L	14	0	0	n/a	n/a	n/a	n/a	n/a	na	na	na	2	n/a	-	n/a	-
Methylnaphthalene[2-]	UF	µg/L	17	0	0	n/a	n/a	n/a	0	n/a	2	na	na	2	0	-	n/a	-
Methylphenol[2-]	UF	µg/L	13	0	0	n/a	n/a	n/a	n/a	n/a	na	na	na	2	n/a	-	n/a	-
Methylphenol[3-,4-]	UF	µg/L	8	0	0	n/a	n/a	n/a	n/a	n/a	na	na	na	2	n/a	-	n/a	-
Methylphenol[4-]	UF	µg/L	5	0	0	n/a	n/a	n/a	n/a	n/a	na	na	na	2	n/a	-	n/a	-
Methylpyridine[2-]	UF	µg/L	1	0	0	n/a	n/a	n/a	n/a	n/a	na	na	na	1	n/a	-	n/a	-
Naphthalene	UF	µg/L	17	0	0	n/a	n/a	n/a	0	n/a	23	na	na	2	0	-	n/a	-
Nitroaniline[2-]	UF	µg/L	17	0	0	n/a	n/a	n/a	n/a	n/a	na	na	na	2	n/a	-	n/a	-
Nitroaniline[3-]	UF	µg/L	17	0	0	n/a	n/a	n/a	n/a	n/a	na	na	na	2	n/a	-	n/a	-
Nitroaniline[4-]	UF	µg/L	17	0	0	n/a	n/a	n/a	n/a	n/a	na	na	na	2	n/a	-	n/a	-
Nitrobenzene	UF	µg/L	19	0	0	n/a	n/a	n/a	0	0	270	690	HHPU	3	0	-	0	-
Nitrophenol[2-]	UF	µg/L	12	0	0	n/a	n/a	n/a	n/a	n/a	na	na	na	2	n/a	-	n/a	-
Nitrophenol[4-]	UF	µg/L	13	0	0	n/a	n/a	n/a	n/a	n/a	na	na	na	2	n/a	-	n/a	-
Nitroso-di-n-butylamine[N-]	UF	µg/L	16	0	0	n/a	n/a	n/a	n/a	n/a	na	na	na	2	n/a	-	n/a	-
Nitroso-di-n-propylamine[N-]	UF	µg/L	17	0	0	n/a	n/a	n/a	n/a	0	na	5.1	HHPU	2	n/a	-	0	-
Nitrosodiethylamine[N-]	UF	µg/L	16	0	0	n/a	n/a	n/a	n/a	n/a	na	na	na	2	n/a	-	n/a	-
Nitrosodimethylamine[N-]	UF	µg/L	17	0	0	n/a	n/a	n/a	n/a	0	na	30	HHPU	2	n/a	-	0	-
Nitrosopyrrolidine[N-]	UF	µg/L	16	0	0	n/a	n/a	n/a	n/a	n/a	na	na	na	2	n/a	-	n/a	-
Nitrotoluene[2-]	UF	µg/L	19	0	0	n/a	n/a	n/a	0	n/a	8000	na	na	3	0	-	n/a	-
Nitrotoluene[3-]	UF	µg/L	19	0	0	n/a	n/a	n/a	0	n/a	9600	na	na	3	0	-	n/a	-
Nitrotoluene[4-]	UF	µg/L	19	0	0	n/a	n/a	n/a	0	n/a	17000	na	na	3	0	-	n/a	-
Oxybis[1-chloropropane][2,2'-]	UF	µg/L	17	0	0	n/a	n/a	n/a	n/a	0	na	65000	HHPU	2	n/a	-	0	-
PETN	UF	µg/L	17	0	0	n/a	n/a	n/a	0	n/a	26000000	na	na	3	0	-	n/a	-
Pentachlorobenzene	UF	µg/L	16	0	0	n/a	n/a	n/a	n/a	n/a	na	na	na	2	n/a	-	n/a	-
Pentachlorophenol	UF	µg/L	13	0	0	n/a	n/a	n/a	0	0	2.4	19	AqAcU	2	0	-	0	-
Phenanthrene	UF	µg/L	17	0	0	n/a	n/a	n/a	0	n/a	6.3	na	na	2	0	-	n/a	-
Phenol	UF	µg/L	13	0	0	n/a	n/a	n/a	0	0	110	1700000	HHPU	2	0	-	0	-
Propionitrile	UF	µg/L	13	0	0	n/a	n/a	n/a	n/a	n/a	na	na	na	2	n/a	-	n/a	-
Propylbenzene[1-]	UF	µg/L	15	0	0	n/a	n/a	n/a	n/a	n/a	na	na	na	2	n/a	-	n/a	-
Pyrene	UF	µg/L	17	0	0	n/a	n/a	n/a	0	0	30	4000	HHPU	2	0	-	0	-
Pyridine	UF	µg/L	9	0	0	n/a	n/a	n/a	n/a	n/a	na	na	na	2	n/a	-	n/a	-
RDX	UF	µg/L	19	0	0	n/a	n/a	n/a	0	n/a	44000	na	na	3	0	-	n/a	-
Styrene	UF	µg/L	16	0	0	n/a	n/a	n/a	n/a	n/a	na	na	na	2	n/a	-	n/a	-
TATB	UF	µg/L	17	0	0	n/a	n/a	n/a	n/a	n/a	na	na	na	3	n/a	-	n/a	-
TNX	UF	µg/L	15	0	0	n/a	n/a	n/a	n/a	n/a	na	na	na	2	n/a	-	n/a	-

Table 6.3-19 (continued)

Constituent			Summary by Sample								Screening Values			Location Summary				
Organics	Field Prep	Units	Total	Detects (D)			Exceedances		wESL ^a	Screening Standard ^b		Locations with Data (Number)	D>wESL (Number of Locations)	D>wESL Station List ^c	D>Std (Number of Locations)	D>Std Station List ^c		
				Number	Rate (%)	Min.	Median	Max.	D>wESL (Number)	D>Std (Number)	Level						Level	Std Type
TP[2,4,5-]	UF	µg/L	4	0	0	n/a	n/a	n/a	n/a	n/a	na	na	na	2	n/a	-	n/a	-
T[2,4,5-]	UF	µg/L	4	0	0	n/a	n/a	n/a	n/a	n/a	na	na	na	2	n/a	-	n/a	-
Tetrachlorobenzene[1,2,4,5]	UF	µg/L	16	0	0	n/a	n/a	n/a	n/a	n/a	na	na	na	2	n/a	-	n/a	-
Tetrachloroethane[1,1,1,2-]	UF	µg/L	16	0	0	n/a	n/a	n/a	n/a	n/a	na	na	na	2	n/a	-	n/a	-
Tetrachloroethane[1,1,2,2-]	UF	µg/L	16	0	0	n/a	n/a	n/a	n/a	0	na	40	HHPU	2	n/a	-	0	-
Tetrachloroethene	UF	µg/L	16	0	0	n/a	n/a	n/a	0	0	120	33	HHPU	2	0	-	0	-
Tetrachlorophenol[2,3,4,6-]	UF	µg/L	12	0	0	n/a	n/a	n/a	n/a	n/a	na	na	na	2	n/a	-	n/a	-
Tetryl	UF	µg/L	19	0	0	n/a	n/a	n/a	0	n/a	5800	na	na	3	0	-	n/a	-
Toluene	UF	µg/L	16	0	0	n/a	n/a	n/a	0	0	130	200000	HHPU	2	0	-	0	-
Toxaphene [Technical Grade]	UF	µg/L	17	0	0	n/a	n/a	n/a	0	0	0.0002	0.0028	HHPU	2	0	-	0	-
Trichloro-1,2,2-trifluoroethane[1,1,2-]	UF	µg/L	16	0	0	n/a	n/a	n/a	n/a	n/a	na	na	na	2	n/a	-	n/a	-
Trichlorobenzene[1,2,3-]	UF	µg/L	14	0	0	n/a	n/a	n/a	n/a	n/a	na	na	na	2	n/a	-	n/a	-
Trichlorobenzene[1,2,4-]	UF	µg/L	17	0	0	n/a	n/a	n/a	0	0	110	940	HHPU	2	0	-	0	-
Trichloroethane[1,1,1-]	UF	µg/L	16	0	0	n/a	n/a	n/a	0	n/a	62	na	na	2	0	-	n/a	-
Trichloroethane[1,1,2-]	UF	µg/L	16	0	0	n/a	n/a	n/a	n/a	0	na	160	HHPU	2	n/a	-	0	-
Trichloroethene	UF	µg/L	16	0	0	n/a	n/a	n/a	0	0	350	300	HHPU	2	0	-	0	-
Trichlorofluoromethane	UF	µg/L	16	0	0	n/a	n/a	n/a	n/a	n/a	na	na	na	2	n/a	-	n/a	-
Trichlorophenol[2,4,5-]	UF	µg/L	12	0	0	n/a	n/a	n/a	n/a	n/a	na	na	na	2	n/a	-	n/a	-
Trichlorophenol[2,4,6-]	UF	µg/L	12	0	0	n/a	n/a	n/a	n/a	0	na	24	HHPU	2	n/a	-	0	-
Trichloropropane[1,2,3-]	UF	µg/L	16	0	0	n/a	n/a	n/a	n/a	n/a	na	na	na	2	n/a	-	n/a	-
Trimethylbenzene[1,2,4-]	UF	µg/L	16	0	0	n/a	n/a	n/a	n/a	n/a	na	na	na	2	n/a	-	n/a	-
Trimethylbenzene[1,3,5-]	UF	µg/L	15	0	0	n/a	n/a	n/a	n/a	n/a	na	na	na	2	n/a	-	n/a	-
Trinitrobenzene[1,3,5-]	UF	µg/L	19	0	0	n/a	n/a	n/a	0	n/a	60000	na	na	3	0	-	n/a	-
Trinitrotoluene[2,4,6-]	UF	µg/L	19	0	0	n/a	n/a	n/a	0	n/a	40000	na	na	3	0	-	n/a	-
Tris [o-cresyl] phosphate	UF	µg/L	16	0	0	n/a	n/a	n/a	n/a	n/a	na	na	na	3	n/a	-	n/a	-

Table 6.3-19 (continued)

Constituent			Summary by Sample								Screening Values			Location Summary				
Organics	Field Prep	Units	Total	Detects (D)			Exceedances		wESL ^a	Screening Standard ^b		Locations with Data (Number)	D>wESL (Number of Locations)	D>wESL Station List ^c	D>Std (Number of Locations)	D>Std Station List ^c		
				Number	Rate (%)	Min.	Median	Max.	D>wESL (Number)	D>Std (Number)	Level						Level	Std Type
Vinyl Chloride	UF	µg/L	16	0	0	n/a	n/a	n/a	0	na	5300	HHPU	2	n/a	-	0	-	
Vinyl acetate	UF	µg/L	14	0	0	n/a	n/a	n/a	n/a	na	na	na	2	n/a	-	n/a	-	
Xylene [Total]	UF	µg/L	1	0	0	n/a	n/a	n/a	0	86	na	na	1	0	-	n/a	-	
Xylene[1,2-]	UF	µg/L	16	0	0	n/a	n/a	n/a	n/a	na	na	na	2	n/a	-	n/a	-	
Xylene[1,3-]+Xylene[1,4-]	UF	µg/L	15	0	0	n/a	n/a	n/a	n/a	na	na	na	2	n/a	-	n/a	-	

Notes: Light grey indicates exceeds groundwater background. Dark grey indicates exceeds standard.

^a Groundwater background UTL or maximum detect for Intermediate Groundwater filtered samples; LANL "Groundwater Background Investigation Report, Revision 3" (2007, 095817).

^d n/a = Not applicable.

^e na = Not available (no published value).

^f - = None.

^b Screening Standard

- AqChrU NMAC 20.6.4, Aquatic Life Chronic (Unfiltered)
Hardness = 100 mg/L
- HHEF NMAC 20.6.4, Human Health Ephemeral (Filtered)
- HHPF NMAC 20.6.4, Human Health Perennial (Filtered)
- HHEU NMAC 20.6.4, Human Health Ephemeral (Unfiltered)
- HHPU NMAC 20.6.4, Human Health Perennial (Unfiltered)
- IrF NMAC 20.6.4, Irrigation Standard (Filtered)
- LWF NMAC 20.6.4, Livestock Watering (Filtered)
- LWU NMAC 20.6.4, Livestock Watering (Unfiltered)
- WHU NMAC 20.6.4, Wildlife Habitat (Unfiltered)

^c Station List (codes)

- | | | |
|----------------------|-----------------------------------|---|
| 1 = Anderson Spring | 11 = Spring 4 C | 21 = Pajarito above Twomile |
| 2 = Bulldog Spring | 12 = Starmer Spring | 22 = Pajarito above Twomile |
| 3 = Charlie's Spring | 13 = TA-18 Spring | 23 = Pajarito at Rio Grande |
| 4 = Homested Spring | 14 = TW-1.72 Spring | 24 = Pajarito below SR-501 |
| 5 = Kieling Spring | 15 = Threemile Spring | 25 = Pajaratio below TA-18 |
| 6 = PC Spring | 16 = La Delfe above Pajarito | 26 = Pajaratio below confluences of South and North Anchor East Basin |
| 7 = Spring 4 | 17 = Pajarito 0.5 mi above SR-501 | 27 = Starmers above Pajarito |
| 8 = Spring 4A | 18 = Pajarito above SR-4 | 28 = Twomile Canyon below TA-59 |
| 9 = Spring 4AA | 19 = Pajarito above Starmers | 29 = Twomile below TA-59 |
| 10 = Spring 4B | 20 = Pajarito above TA-18 | 31 = Twomile above Pajarito |

Table 6.3-20
Screening Table for Pajarito Watershed General Inorganics in Surface Water (Base Flow and Springs)

Constituent			Summary by Sample							Screening Values			Location Summary					
General Inorganics	Field Prep	Units	Total	Detects (D)			Exceedances		wESL ^a	Screening Standard ^b		Locations with Data (Number)	D>wESL(Number of Locations)	D>wESL Station List ^c	D>Std (Number of Locations)	D>Std Station List ^c		
				Number	Rate (%)	Min.	Median	Max.	D>wESL (Number)	D>Std (Number)	Level						Level	Std Type
Ephemeral and Intermittent																		
Alkalinity-CO ³	F	µg/L	132	3	2.27	740	1120	1200	n/a ^d	n/a	Na ^e	na	na	22	n/a	- ^f	n/a	-
Alkalinity-CO ³ +HCO ³	F	µg/L	132	132	100	7150	50550	95800	n/a	n/a	na	na	na	22	n/a	-	n/a	-
Alkalinity-HCO ³	F	µg/L	15	15	100	34600	74200	87900	n/a	n/a	na	na	na	11	n/a	-	n/a	-
Ammonia as Nitrogen	F	µg/L	105	28	26.7	27	50.75	1960	n/a	n/a	na	na	na	18	n/a	-	n/a	-
Bromide	F	µg/L	117	18	15.4	61	84	228	n/a	n/a	na	na	na	22	n/a	-	n/a	-
Calcium	F	µg/L	136	135	99.3	6180	14300	46300	n/a	n/a	na	na	na	25	n/a	-	n/a	-
Chloride	F	µg/L	132	131	99.2	917	7460	164000	0	n/a	230000	na	na	22	0	-	n/a	-
Cyanide [Total]	F	µg/L	47	6	12.8	1.66	2.23	6.4	1	n/a	5.2	na	na	22	1	11	n/a	-
Fluoride	F	µg/L	132	121	91.7	60	181	535	0	n/a	1600	na	na	22	0	-	n/a	-
Hardness	F	µg/L	136	136	100	25700	52650	161000	n/a	n/a	na	na	na	25	n/a	-	n/a	-
Magnesium	F	µg/L	136	135	99.3	2500	4200	11200	n/a	n/a	na	na	na	25	n/a	-	n/a	-
Nitrate-Nitrite as Nitrogen	F	µg/L	123	110	89.4	10	455	1660	n/a	n/a	na	na	na	21	n/a	-	n/a	-
Perchlorate	F	µg/L	117	107	91.5	0.0569	0.405	0.837	0	n/a	35000	na	na	22	0	-	n/a	-
Potassium	F	µg/L	136	135	99.3	1720	2800	7670	n/a	n/a	na	na	na	25	n/a	-	n/a	-
Silicon Dioxide	F	µg/L	129	128	99.2	22400	40000	81700	n/a	n/a	na	na	na	24	n/a	-	n/a	-
Sodium	F	µg/L	136	135	99.3	3580	13000	103000	n/a	n/a	na	na	na	25	n/a	-	n/a	-
Specific Conductance	F	uS/cm	132	132	100	72.6	183.5	710	n/a	n/a	na	na	na	22	n/a	-	n/a	-
Sulfate	F	µg/L	132	131	99.2	2780	8650	37100	n/a	n/a	na	na	na	22	n/a	-	n/a	-
Total Dissolved Solids	F	µg/L	132	131	99.2	8000	154000	427000	n/a	n/a	na	na	na	22	n/a	-	n/a	-
Total Kjeldahl Nitrogen	F	µg/L	76	48	63.2	17	190.5	10700	n/a	n/a	na	na	na	22	n/a	-	n/a	-
Total Organic Carbon	F	µg/L	9	9	100	6900	9040	11300	n/a	n/a	na	na	na	9	n/a	-	n/a	-
Total Phosphate as Phosphorus	F	µg/L	126	38	30.2	12	74	1090	n/a	n/a	na	na	na	22	n/a	-	n/a	-
pH	F	SU	132	132	100	6.09	7.44	8.16	n/a	n/a	na	na	na	22	n/a	-	n/a	-
Alkalinity-CO ³	UF	µg/L	35	3	8.57	989	1070	3590	n/a	n/a	na	na	na	23	n/a	-	n/a	-
Alkalinity-CO ³ +HCO ³	UF	µg/L	35	35	100	26400	49200	95100	n/a	n/a	na	na	na	23	n/a	-	n/a	-
Alkalinity-HCO ³	UF	µg/L	12	12	100	26300	36200	94200	n/a	n/a	na	na	na	12	n/a	-	n/a	-
Ammonia as Nitrogen	UF	µg/L	21	5	23.8	17	52	1420	n/a	0	na	39100	AqAcU	16	n/a	-	0	-
Bromide	UF	µg/L	23	3	13	75	77	95	n/a	n/a	na	na	na	16	n/a	-	n/a	-
Calcium	UF	µg/L	133	133	100	6200	14700	47500	n/a	n/a	na	na	na	27	n/a	-	n/a	-
Chemical Oxygen Demand	UF	µg/L	10	10	100	13100	18650	32600	n/a	n/a	na	na	na	10	n/a	-	n/a	-
Chloride	UF	µg/L	26	26	100	1070	7705	37600	0	n/a	230000	na	na	16	0	-	n/a	-
Cyanide [Total]	UF	µg/L	105	16	15.2	1.58	2.86	24.4	2	n/a	5.2	na	na	24	2	4, 31	n/a	-
Cyanide, Amenable to Chlorination	UF	µg/L	7	0	0	n/a	n/a	n/a	n/a	0	na	22	AqAcU	6	n/a	-	0	-
Fluoride	UF	µg/L	26	22	84.6	71	205.5	532	0	n/a	1600	na	na	16	0	-	n/a	-

Table 6.3-20 (continued)

Constituent			Summary by Sample							Screening Values			Location Summary					
General Inorganics	Field Prep	Units	Total	Detects (D)			Exceedances		wESL ^a	Screening Standard ^b		Locations with Data (Number)	D>wESL (Number of Locations)	D>wESL Station List ^c	D>Std (Number of Locations)	D>Std Station List ^c		
				Number	Rate (%)	Min.	Median	Max.	D>wESL (Number)	D>Std (Number)	Level						Level	Std Type
Hardness	UF	µg/L	133	133	100	26000	54800	166000	n/a	n/a	na	na	na	27	n/a	-	n/a	-
Magnesium	UF	µg/L	133	133	100	2550	4350	11500	n/a	n/a	na	na	na	27	n/a	-	n/a	-
Nitrate-Nitrite as Nitrogen	UF	µg/L	26	24	92.3	30.2	387.5	1620	n/a	0	na	132000	LWU	16	n/a	-	0	-
Perchlorate	UF	µg/L	30	28	93.3	0.0525	0.4715	1.09	0	n/a	35000	na	na	21	0	-	n/a	-
Potassium	UF	µg/L	133	133	100	1680	3020	7920	n/a	n/a	na	na	na	27	n/a	-	n/a	-
Silicon Dioxide	UF	µg/L	44	44	100	26400	45900	85400	n/a	n/a	na	na	na	24	n/a	-	n/a	-
Sodium	UF	µg/L	133	133	100	3830	13200	102000	n/a	n/a	na	na	na	27	n/a	-	n/a	-
Specific Conductance	UF	µS/cm	26	26	100	79.1	200	304	n/a	n/a	na	na	na	16	n/a	-	n/a	-
Sulfate	UF	µg/L	26	26	100	3890	8165	11000	n/a	n/a	na	na	na	16	n/a	-	n/a	-
Suspended Sediment Concentration	UF	µg/L	122	90	73.8	1070	4600	95400	n/a	n/a	na	na	na	27	n/a	-	n/a	-
Total Kjeldahl Nitrogen	UF	µg/L	94	61	64.9	26	167	1140	n/a	n/a	na	na	na	18	n/a	-	n/a	-
Total Organic Carbon	UF	µg/L	95	92	96.8	384	4060	13900	n/a	n/a	na	na	na	18	n/a	-	n/a	-
Total Phosphate as Phosphorus	UF	µg/L	22	8	36.4	13	66	102	n/a	n/a	na	na	na	14	n/a	-	n/a	-
Total Suspended Solids	UF	µg/L	34	24	70.6	1600	5300	124000	n/a	n/a	na	na	na	19	n/a	-	n/a	-
pH	UF	SU	26	26	100	6.48	7.5	8.23	n/a	n/a	na	na	na	16	n/a	-	n/a	-
Perennial																		
Alkalinity-CO ³	F	µg/L	18	0	0	n/a	n/a	n/a	n/a	n/a	na	na	na	3	n/a	-	n/a	-
Alkalinity-CO ³ +HCO ³	F	µg/L	18	18	100	29300	38600	57700	n/a	n/a	na	na	na	3	n/a	-	n/a	-
Alkalinity-HCO ³	F	µg/L	2	2	100	37900	47750	57600	n/a	n/a	na	na	na	2	n/a	-	n/a	-
Ammonia as Nitrogen	F	µg/L	14	0	0	n/a	n/a	n/a	n/a	n/a	na	na	na	2	n/a	-	n/a	-
Bromide	F	µg/L	17	1	5.88	124	124	124	n/a	n/a	na	na	na	3	n/a	-	n/a	-
Calcium	F	µg/L	19	19	100	8200	11500	16100	n/a	n/a	na	na	na	3	n/a	-	n/a	-
Chloride	F	µg/L	19	19	100	3560	10800	25600	0	n/a	230000	na	na	3	0	-	n/a	-
Cyanide [Total]	F	µg/L	7	2	28.6	6.86	9.58	12.3	2	n/a	5.2	na	na	3	1	3	n/a	-
Fluoride	F	µg/L	19	16	84.2	86	106.5	168	0	n/a	1600	na	na	3	0	-	n/a	-
Hardness	F	µg/L	19	19	100	32200	44000	61600	n/a	n/a	na	na	na	3	n/a	-	n/a	-
Magnesium	F	µg/L	19	19	100	2840	3670	5220	n/a	n/a	na	na	na	3	n/a	-	n/a	-
Nitrate-Nitrite as Nitrogen	F	µg/L	18	16	88.9	83	283	626	n/a	n/a	na	na	na	3	n/a	-	n/a	-
Perchlorate	F	µg/L	17	17	100	0.213	0.301	0.457	0	n/a	35000	na	na	3	0	-	n/a	-
Potassium	F	µg/L	19	19	100	2200	2650	3350	n/a	n/a	na	na	na	3	n/a	-	n/a	-
Silicon Dioxide	F	µg/L	19	19	100	31200	36700	53000	n/a	n/a	na	na	na	3	n/a	-	n/a	-
Sodium	F	µg/L	19	19	100	6780	10400	15400	n/a	n/a	na	na	na	3	n/a	-	n/a	-
Specific Conductance	F	µS/cm	19	19	100	102	135	191	n/a	n/a	na	na	na	3	n/a	-	n/a	-
Sulfate	F	µg/L	19	19	100	5740	7820	15100	n/a	n/a	na	na	na	3	n/a	-	n/a	-
Total Dissolved Solids	F	µg/L	19	19	100	93000	122000	195000	n/a	n/a	na	na	na	3	n/a	-	n/a	-
Total Kjeldahl Nitrogen	F	µg/L	11	8	72.7	39	186.5	300	n/a	n/a	na	na	na	3	n/a	-	n/a	-
Total Organic Carbon	F	µg/L	1	1	100	9760	9760	9760	n/a	n/a	na	na	na	1	n/a	-	n/a	-

Table 6.3-20 (continued)

Constituent			Summary by Sample								Screening Values			Location Summary				
General Inorganics	Field Prep	Units	Total	Detects (D)			Exceedances		wESL ^a	Screening Standard ^b		Locations with Data (Number)	D> wESL (Number of Locations)	D>wESL Station List ^c	D>Std (Number of Locations)	D>Std Station List ^c		
				Number	Rate (%)	Min.	Median	Max.	D>wESL (Number)	D>Std (Number)	Level						Level	Std Type
Total Phosphate as Phosphorus	F	µg/L	19	7	36.8	31	86	101	n/a	n/a	na	na	na	3	n/a	-	n/a	-
pH	F	SU	19	19	100	6.39	6.99	7.87	n/a	n/a	na	na	na	3	n/a	-	n/a	-
Alkalinity-CO ³	UF	µg/L	6	0	0	n/a	n/a	n/a	n/a	n/a	na	na	na	3	n/a	-	n/a	-
Alkalinity-CO ³ +HCO ³	UF	µg/L	6	6	100	29600	42050	52900	n/a	n/a	na	na	na	3	n/a	-	n/a	-
Alkalinity-HCO ³	UF	µg/L	1	1	100	29400	29400	29400	n/a	n/a	na	na	na	1	n/a	-	n/a	-
Ammonia as Nitrogen	UF	µg/L	4	1	25	86	86	86	n/a	0	na	8190	AqChrU	2	n/a	-	0	-
Bromide	UF	µg/L	4	0	0	n/a	n/a	n/a	n/a	n/a	na	na	na	2	n/a	-	n/a	-
Calcium	UF	µg/L	18	18	100	8360	11900	16300	n/a	n/a	na	na	na	3	n/a	-	n/a	-
Chemical Oxygen Demand	UF	µg/L	2	2	100	14200	17500	20800	n/a	n/a	na	na	na	2	n/a	-	n/a	-
Chloride	UF	µg/L	4	4	100	9600	10490	20700	0	n/a	230000	na	na	2	0	-	n/a	-
Cyanide [Total]	UF	µg/L	14	3	21.4	2.05	3.36	5.33	1	n/a	5.2	na	na	3	1	27	n/a	-
Cyanide, Amenable to Chlorination	UF	µg/L	1	1	100	2.51	2.51	2.51	n/a	0	na	22	AqAcU	1	n/a	-	0	-
Fluoride	UF	µg/L	4	4	100	91	101	109	0	n/a	1600	na	na	2	0	-	n/a	-
Hardness	UF	µg/L	18	18	100	32700	46150	65900	n/a	n/a	na	na	na	3	n/a	-	n/a	-
Magnesium	UF	µg/L	18	18	100	2880	4015	6170	n/a	n/a	na	na	na	3	n/a	-	n/a	-
Nitrate-Nitrite as Nitrogen	UF	µg/L	4	4	100	202	279.5	397	n/a	0	na	132000	LWU	2	n/a	-	0	-
Perchlorate	UF	µg/L	3	3	100	0.145	0.254	0.431	0	n/a	35000	na	na	2	0	-	n/a	-
Potassium	UF	µg/L	18	18	100	2300	3015	4190	n/a	n/a	na	na	na	3	n/a	-	n/a	-
Silicon Dioxide	UF	µg/L	6	6	100	34600	38450	44700	n/a	n/a	na	na	na	3	n/a	-	n/a	-
Sodium	UF	µg/L	18	18	100	6940	11600	15600	n/a	n/a	na	na	na	3	n/a	-	n/a	-
Specific Conductance	UF	µS/cm	4	4	100	110	136	199	n/a	n/a	na	na	na	2	n/a	-	n/a	-
Sulfate	UF	µg/L	4	4	100	7830	8800	10000	n/a	n/a	na	na	na	2	n/a	-	n/a	-
Suspended Sediment Concentration	UF	µg/L	15	8	53.3	1200	4780	58400	n/a	n/a	na	na	na	3	n/a	-	n/a	-

Table 6.3-20 (continued)

Constituent			Summary by Sample								Screening Values			Location Summary				
General Inorganics	Field Prep	Units	Total	Detects (D)			Exceedances		wESL ^a	Screening Standard ^b		Locations with Data (Number)	D> wESL (Number of Locations)	D>wESL Station List ^c	D>Std (Number of Locations)	D>Std Station List ^c		
				Number	Rate (%)	Min.	Median	Max.	D>wESL (Number)	D>Std (Number)	Level						Level	Std Type
Total Kjeldahl Nitrogen	UF	µg/L	13	9	69.2	66	208	339	n/a	n/a	na	na	na	2	n/a	-	n/a	-
Total Organic Carbon	UF	µg/L	13	13	100	2790	6110	8010	n/a	n/a	na	na	na	2	n/a	-	n/a	-
Total Phosphate as Phosphorus	UF	µg/L	4	1	25	37	37	37	n/a	n/a	na	na	na	2	n/a	-	n/a	-
Total Suspended Solids	UF	µg/L	6	6	100	1000	4600	28000	n/a	n/a	na	na	na	3	n/a	-	n/a	-
pH	UF	SU	4	4	100	6.59	6.67	6.91	n/a	n/a	na	na	na	2	n/a	-	n/a	-

Notes: Light grey indicates exceeds groundwater background. Dark grey indicates exceeds standard.

^a Groundwater background UTL or maximum detect for Intermediate Groundwater filtered samples; LANL "Groundwater Background Investigation Report, Revision 3" (2007, 095817).
^b Screening Standard
^c Station List (codes)
^d n/a = Not applicable.
^e na = Not available (no published value).
^f - = None.

- AqChrU NMAC 20.6.4, Aquatic Life Chronic (Unfiltered)
Hardness = 100 mg/L
- HHEF NMAC 20.6.4, Human Health Ephemeral (Filtered)
- HHPF NMAC 20.6.4, Human Health Perennial (Filtered)
- HHEU NMAC 20.6.4, Human Health Ephemeral (Unfiltered)
- HHPU NMAC 20.6.4, Human Health Perennial (Unfiltered)
- IrF NMAC 20.6.4, Irrigation Standard (Filtered)
- LWF NMAC 20.6.4, Livestock Watering (Filtered)
- LWU NMAC 20.6.4, Livestock Watering (Unfiltered)
- WHU NMAC 20.6.4, Wildlife Habitat (Unfiltered)

- 1 = Anderson Spring
- 2 = Bulldog Spring
- 3 = Charlie's Spring
- 4 = Homestead Spring
- 5 = Kieling Spring
- 6 = PC Spring
- 7 = Spring 4
- 8 = Spring 4A
- 9 = Spring 4AA
- 10 = Spring 4B
- 11 = Spring 4 C
- 12 = Starmer Spring
- 13 = TA-18 Spring
- 14 = TW-1.72 Spring
- 15 = Threemile Spring
- 16 = La Delfe above Pajarito
- 17 = Pajarito 0.5 mi above SR-501
- 18 = Pajarito above SR-4
- 19 = Pajarito above Starmers
- 20 = Pajarito above TA-18
- 21 = Pajarito above Twomile
- 22 = Pajarito above Twomile
- 23 = Pajarito at Rio Grande
- 24 = Pajarito below SR-501
- 25 = Pajarito below TA-18
- 26 = Pajarito below confluences of South and North Anchor East Basin
- 27 = Starmers above Pajarito
- 28 = Twomile Canyon below TA-59
- 29 = Twomile below TA-59
- 31 = Twomile above Pajarito

**Table 6.4-1
Pajarito Alluvial Core Inorganic COPCs**

	Aluminum	Arsenic	Barium	Beryllium	Cadmium	Chromium	Cobalt	Iron	Lead	Manganese	Nickel	Selenium	Silver	Thallium	Uranium	Vanadium	Zinc
LANL ALLH BV^a	29200	8.17	295	1.83	0.4	19.3	8.64	21500	22.3	671	15.4	1.52	1	0.73	1.82	39.6	48.8
Location ID																	
3MAO-1A	— ^b	—	—	—	0.606 (U)	—	—	—	—	—	—	—	—	—	—	—	—
3MAO-2	—	—	—	2.92	0.68 (U)	—	21.6	—	—	772	—	2.75	—	1.36	—	—	59.1
PCAO-2	—	9.48 (U)	—	—	0.632 (U)	—	—	—	—	—	—	—	—	—	—	—	—
PCAO-3	—	—	—	—	—	—	—	—	—	—	21.4	—	1.25	—	—	—	—
PCAO-4	—	8.69 (U)	—	—	0.579 (U)	—	—	—	—	—	—	2.1	—	—	—	—	—
PCAO-5	50000	—	327	8.59 (J)	0.675 (U)	—	—	—	40.5	—	—	12.7	—	1.25 (J)	4.53	—	79.6
PCAO-6	—	—	—	—	0.575 (U)	—	—	—	60.2	—	—	1.97	—	1.08	—	—	—
PCAO-7a	—	—	—	2.63	0.646 (U)	40.1 (J-)	—	—	—	—	—	4.48	—	0.899	2.74	—	—
PCAO-7b2	—	—	—	—	0.573 (U)	—	—	—	—	—	—	1.87 (U)	—	—	—	—	64.5
PCAO-7c	—	—	—	—	0.601 (U)	—	—	—	—	—	—	6.01	—	—	—	—	—
PCAO-8	46300	13.4 (J)	397 (J+)	3.13	0.697 (U)	—	12.1	24500	49.3	1260	—	2.09 (U)	—	—	2.76	43.5	90.5
PCAO-9	—	—	—	2.18	0.683 (U)	39.2	—	—	—	—	—	2.04	—	—	—	—	—
TMO-1	—	—	—	—	0.604 (U)	—	—	—	—	—	—	—	—	—	—	—	—

Notes: Values are in mg/kg. All values are maximum values > BV.

^a LANL (1998, 59730).

^b — = Not detected, not detected >BV, or not analyzed.

Table 6.4-2
Pajarito Alluvial Core Organic COPCs

Location ID	Aroclor-1242	Aroclor-1248	Aroclor-1254	Aroclor-1260	Isopropyltoluene[4-]
3MAO-1A	—*	—	—	—	0.00134
PCAO-7a	—	—	0.0071	—	—
PCAO-7b2	0.003 (J)	—	—	—	—
PCAO-7c	0.0031 (J)	0.0859	0.0059	0.0059	—
PCAO-8	—	—	0.0034 (J)	—	—

Notes: Values are in mg/kg. All values are maximum values >BV.

* — = Not detected, not detected >BV, or not analyzed.

Table 6.4-3
Pajarito Alluvial Core Radionuclide COPCs

Location ID	Uranium-234	Uranium-235/236	Uranium-238
LANL ALLH BV^a	2.59	0.2	2.29
PCAO-6	3.23	0.231	3.41
PCAO-7a	3.17 (J)	— ^b	3.2 (J)
PCAO-7b2	3.11	0.248	3.08
PCAO-8	2.73 (J)	—	2.98 (J)
PCAO-9	3.25	0.208	3.41

Notes: Values are in pCi/g. Values are maximum detected values >BV.

^a LANL (1998, 59730).

^b — = Not detected, not detected >BV, or not analyzed.

Table 6.5-1
Pajarito COPC Summary

Analyte	Sediment	Water	Alluvial Core
Aluminum	x ^a	x ^b	x
Ammonia as Nitrogen	- ^c	x	-
Antimony	x	x	-
Arsenic	x	x	x
Barium	x	x	x
Beryllium	x	x	x
Boron	-	x	-
Bromide	-	x	-
Cadmium	x	x	x
Calcium	x	x	-
Chloride	-	x	-
Chromium	x	x	x
Chromium hexavalent ion	-	x	-
Cobalt	x	x	x
Copper	x	x	-

Table 6.5-1 (continued)

Analyte	Sediment	Water	Alluvial Core
Cyanide [Total]	X	X	-
Cyanide, Amenable to Chlorination	-	X	-
Fluoride	-	X	-
Iron	X	X	X
Lead	X	X	X
Magnesium	X	X	-
Manganese	X	X	X
Mercury	X	X	-
Molybdenum	-	X	-
Nickel	X	X	X
Nitrate	X	-	-
Nitrate-Nitrite as Nitrogen	-	X	-
Nitrite as Nitrogen	-	X	-
Oxalate	-	X	-
Perchlorate	X	X	-
Phosphorus, Orthophosphate [Expressed as PO4]	-	X	-
Potassium	X	X	-
Selenium	X	X	X
Silver	X	X	X
Sodium	-	X	-
Strontium	-	X	-
Sulfate	-	X	-
Thallium	X	X	X
Tin	-	X	-
Total Kjeldahl Nitrogen	-	X	-
Total Phosphate as Phosphorus	-	X	-
Uranium	X	X	X
Vanadium	X	X	X
Zinc	X	X	X
Acenaphthene	X	-	-
Acenaphthylene	X	-	-
Acetone	X	X	-
Acetonitrile	-	X	-
Aldrin	-	X	-
Amino-2,6-dinitrotoluene[4-]	X	X	-
Amino-4,6-dinitrotoluene[2-]	X	-	-
Aniline	X	-	-
Anthracene	X	-	-
Aroclor-1242	X	X	X
Aroclor-1248	X	-	X
Aroclor-1254	X	X	X
Aroclor-1260	X	X	X
BHC[alpha-]	X	X	-
BHC[beta-]	X	X	-

Table 6.5-1 (continued)

Analyte	Sediment	Water	Alluvial Core
BHC[delta-]	-	X	-
BHC[gamma-]	X	X	-
Benzo[a]anthracene	X	-	-
Benzo[a]pyrene	X	X	-
Benzo[b]fluoranthene	X	X	-
Benzo[g,h,i]perylene	X	X	-
Benzo[k]fluoranthene	X	X	-
Benzoic Acid	X	X	-
Bis[2-chloroethyl]ether	X	-	-
Bis[2-ethylhexyl]phthalate	X	X	-
Bromoform	-	X	-
Butanol[1-]	-	X	-
Butanone[2-]	X	X	-
Butylbenzene[n-]	X	-	-
Butylbenzylphthalate	X	X	-
Carbon Disulfide	X	X	-
Chlordane[alpha-]	X	-	-
Chlordane[gamma-]	X	X	-
Chloro-3-methylphenol[4-]	X	-	-
Chloroform	X	X	-
Chloronaphthalene[2-]	X	-	-
Chlorophenol[2-]	-	X	-
Chrysene	X	-	-
DDD[4,4'-]	X	X	-
DDE[4,4'-]	X	X	-
DDT[4,4'-]	X	X	-
Di-n-butylphthalate	X	X	-
Diamino-4-nitrotoluene[2,6]	-	X	-
Dibenz[a,h]anthracene	-	X	-
Dibenzofuran	X	-	-
Dichlorobenzene[1,2-]	-	X	-
Dichlorobenzene[1,3-]	X	X	-
Dichlorobenzene[1,4-]	X	-	-
Dichloroethane[1,1-]	-	X	-
Dichloroethane[1,2-]	X	-	-
Dichloroethene[1,1-]	X	X	-
Dieldrin	X	X	-
Diethyl Ether	-	X	-
Diethylphthalate	-	X	-
Dinitrotoluene[2,4-]	X	-	-
Dinitrotoluene[2,6-]	X	-	-
Dioxane[1,4-]	-	X	-
Endosulfan I	-	X	-
Endosulfan II	-	X	-
Endosulfan Sulfate	-	X	-

Table 6.5-1 (continued)

Analyte	Sediment	Water	Alluvial Core
Endrin	-	X	-
Endrin Aldehyde	-	X	-
Endrin Ketone	-	X	-
Ethylbenzene	X	-	-
Fluoranthene	X	-	-
Fluorene	X	-	-
HMX	X	X	-
Heptachlor	-	X	-
Heptachlor Epoxide	X	X	-
1,2,3,4,6,7,8-HpCDD	X	-	-
Total-HpCDD	X	X	-
1,2,3,4,6,7,8-HpCDF	X	-	-
1,2,3,4,7,8,9-HpCDF	X	-	-
Total-HpCDF	X	X	-
1,2,3,4,7,8-HxCDD	X	-	-
1,2,3,6,7,8-HxCDD	X	-	-
1,2,3,7,8,9-HxCDD	X	-	-
Total-HxCDD	X	-	-
1,2,3,4,7,8-HxCDF	X	-	-
1,2,3,6,7,8-HxCDF	X	-	-
1,2,3,7,8,9-HxCDF	X	-	-
2,3,4,6,7,8-HxCDF	X	-	-
Total-HxCDF	X	-	-
Indeno[1,2,3-cd]pyrene	X	X	-
Isopropylbenzene	-	X	-
Isopropyltoluene[4-]	X	-	X
Methyl Methacrylate	-	X	-
Methyl-2-pentanone[4-]	X	X	-
Methylene Chloride	X	X	-
Methylnaphthalene[2-]	X	-	-
Methylphenol[4-]	X	-	-
Naphthalene	X	X	-
Nitrobenzene	X	X	-
Nitrophenol[2-]	X	-	-
Nitrotoluene[2-]	X	-	-
Nitrotoluene[3-]	X	-	-
1,2,3,4,6,7,8,9-OCDD	X	X	-
1,2,3,4,6,7,8,9-OCDF	X	-	-
1,2,3,7,8-PeCDD	X	-	-
Total-PeCDD	X	-	-
1,2,3,7,8-PeCDF	X	-	-
2,3,4,7,8-PeCDF	X	X	-
Total-PeCDF	X	X	-
Phenanthrene	X	-	-
Phenol	X	X	-

Table 6.5-1 (continued)

Analyte	Sediment	Water	Alluvial Core
Pyrene	x	-	-
Pyridine	x	-	-
RDX	x	x	-
Styrene	x	x	-
TATB	x	x	-
2,3,7,8-TCDD	x	-	-
Total-TCDD	x	-	-
2,3,7,8-TCDF	x	x	-
Total-TCDF	x	x	-
Tetrachloroethene	x	x	-
Tetryl	x	-	-
Toluene	x	x	-
Total Petroleum Hydrocarbons-Diesel Range Organics	-	x	-
Total Petroleum Hydrocarbons-Gasoline Range Org.	-	x	-
Toxaphene [Technical Grade]	x	-	-
Trichlorobenzene[1,2,3-]	-	x	-
Trichloroethane[1,1,1-]	x	x	-
Trichloroethane[1,1,2-]	-	x	-
Trichloroethene	x	x	-
Trimethylbenzene[1,2,4-]	x	x	-
Trimethylbenzene[1,3,5-]	x	-	-
Trinitrotoluene[2,4,6-]	x	-	-
Xylene[1,2-]	x	-	-
Xylene[1,3-]+Xylene[1,4-]	x	x	-
Americium-241	x	x	-
Cesium-134	x	-	-
Cesium-137	x	x	-
Cobalt-60	-	x	-
Plutonium-238	x	x	-
Plutonium-239/240	x	x	-
Potassium-40	-	x	-
Radium-226	-	x	-
Radium-228	-	x	-
Strontium-90	-	x	-
Thorium-228	x	x	-
Thorium-230	-	x	-
Thorium-232	x	x	-
Tritium	x	x	-
Uranium-234	x	x	x
Uranium-235/236	x	x	x
Uranium-238	x	x	x

^a x = Analyte is a COPC for given medium.

^b Grey shading = Analyte exceeded residential SSL, SAL, or standard (for sediment and water only).

^c - = Analyte is not a COPC for given medium.

**Table 7.1-1
Inferred Primary Sources and Downcanyon Extent of Select COPCs in Sediment in the Pajarito Watershed**

Type of COPC	COPC	Inferred Primary Source(s) in the Pajarito Watershed ^a	Inferred Downcanyon Extent from Laboratory Sources ^b
Inorganic Chemical	Aluminum	Natural background	n/a ^c
	Antimony	Natural background	n/a
	Arsenic	TA-08 and natural background	Anchor West basin
	Barium	TA-08 and Cerro Grande burn area, ± TA-09, TA-15, and TA-69	Pajarito Canyon between Twomile and Threemile Canyons
	Cadmium	TA-09 ± TA-08	Lower Pajarito Canyon below White Rock
	Chromium	TA-08 ± TA-09, TA-15, and TA-22	Lower Pajarito Canyon below White Rock
	Copper	TA-22 and TA-15 ± TA-08, TA-09, TA-40	Lower Pajarito Canyon below White Rock
	Cyanide (total)	TA-22 and Cerro Grande burn area	Upper part of southeast fork Twomile Canyon
	Iron	Natural background	n/a
	Lead	TA-08, TA-15, and runoff from paved areas	Anchor West basin and middle fork Threemile Canyon
	Manganese	Cerro Grande burn area and natural background	n/a
	Mercury	TA-08 and TA-09	Anchor West basin and north Anchor East basin
	Perchlorate	Natural background	n/a
	Silver	TA-08 ± TA-09 and TA-69	Pajarito Canyon between Twomile and Threemile Canyons
	Thallium	TA-09	North Anchor East basin
	Uranium (total)	TA-15	Lower Threemile Canyon
	Vanadium	TA-08 and natural background	Anchor West basin
Zinc	Runoff from roads and other paved areas	n/a	

Table 7.1-1 (continued)

Type of COPC	COPC	Inferred Primary Source(s) in the Pajarito Watershed ^a	Inferred Downcanyon Extent from Laboratory Sources ^b
Organic Chemical	Anthracene	Runoff from roads and other developed areas	n/a ^c
	Aroclor-1242	White Rock townsite	n/a
	Aroclor-1248	TA-69 and TA-03	Twomile Canyon between north fork and southwest fork
	Aroclor-1254	TA-08 and TA-03 (smaller amounts from several other TAs)	Pajarito Canyon between reaches PA-3E and PA-4
	Aroclor-1260	TA-08 and TA-03 (smaller amounts from several other TAs)	Lower Pajarito Canyon below White Rock
	Benzo(a)anthracene	Runoff from roads and other developed areas	n/a
	Benzo(a)pyrene	Runoff from roads and other developed areas	n/a
	Benzo(b)fluoranthene	Runoff from roads and other developed areas	n/a
	Benzoic acid	Natural background and/or false positives	n/a
	Bis(2-ethylhexyl)phthalate	TA-15, TA-08, and TA-40	Small tributaries below sources
	DDT	Santa Fe National Forest and Laboratory groundskeeping	n/a
	Di-n-butylphthalate	TA-08	Anchor West basin
	Naphthalene	TA-08	Lower south fork Pajarito Canyon
	TATB	TA-09	Pajarito Canyon between reaches PA-3E and PA-4
	TCDD	TA-69 and Cerro Grande burn area	Pajarito Canyon below reach PA-3E
TCDF	TA-69	Pajarito Canyon below reach PA-3E	
Radionuclide	Cesium-137	Cerro Grande burn area	n/a
	Plutonium-239,240	Cerro Grande burn area	n/a
	Thorium-228	Natural background	n/a
	Thorium-232	Natural background	n/a
	Uranium-238	TA-15	Lower Threemile Canyon

^a Primary source(s) indicated by maximum concentrations and/or spatial distribution.

^b Downcanyon extent indicates area where COPC remains detected and/or above background and can be traced to an upcanyon Laboratory source.

^c n/a = Not applicable (inferred source includes Cerro Grande burn area, natural background, and roads and other developed areas).

**Table 8.1-1
COPECs by Media and Lines of Evidence Supporting Investigation of Each COPEC**

Media	Study Design COPEC ^a	Lines of Evidence	Uncertainty in Line of Evidence		
Soil	Antimony Barium Chromium Copper Manganese Perchlorate Selenium Silver Thallium Vanadium Zinc	Plant toxicity study	Collected soil samples generally represent worst-case concentrations of COPECs and thus likely overestimate exposure concentrations.		
			Variability in the test organism response may limit the ability of the test to detect statistical differences.		
			Confounding factors (e.g., nutrient enrichment) may affect results.		
	Antimony Cadmium Chromium Copper Cyanide (total) Lead Mercury Perchlorate Thallium Vanadium Zinc Aroclor-1248 Aroclor-1254 Bis(2-ethylhexyl)phthalate Di-n-butyl phthalate TCDD	Earthworm toxicity and bioaccumulation study (including tissue concentrations for risk to robin, deer mouse, or shrew)	Collected soil samples generally represent worst-case concentrations of COPECs and thus likely overestimate exposure concentrations for populations.		
			Variability in the test organism response may limit the ability of the test to detect statistical differences.		
			Confounding factors (e.g., particle size or organic matter) may affect results.		
			Antimony Cadmium Copper Cyanide (total) ^b Lead Mercury ^b Perchlorate Thallium Vanadium Zinc Aroclor-1248 ^b Aroclor-1254 Bis(2-ethylhexyl)phthalate Di-n-butyl phthalate TCDD	Nest box studies (including insect concentrations for risk to robin, deer mouse, or shrew; egg concentrations for risk to spotted owl or red fox)	Mean concentrations in investigation reaches generally represent worst-case concentrations of COPECs and thus likely overestimate exposures that resulted in egg or insect concentrations or exposures to adult populations.
					Factors other than COPECs (e.g., precipitation) may affect field measures of populations.
					Exposures occur throughout the bird home range and reflect contaminant sources beyond affected media in the canyons.

Table 8.1-1 (continued)

Media	Study Design COPEC ^a	Lines of Evidence	Uncertainty in Line of Evidence
Sediment	Anthracene Barium Benzoic acid Cyanide (total) Iron Manganese Silver Aroclor-1254 Aroclor-1260 DDT[4,4'-]	Chironomid toxicity studies	Selected locations or measurements may not capture all potential effects. Collected sediment samples generally represent worst-case concentrations of COPECs and thus likely overestimate exposure concentrations for populations.
	Anthracene Barium Benzoic acid Cyanide (total) Iron Manganese Silver Aroclor-1254 Aroclor-1260 DDT[4,4'-]	Aquatic community diversity and abundance	Differences in habitat may overwhelm any potential for contaminant effects. Community measures may rebound and thus reflect only current conditions
	Aluminum ^b Aroclor-1248 ^b Aroclor-1254 ^b Bis(2-ethylhexyl)phthalate ^b Cyanide (total) ^b Di-n-butyl phthalate ^b Mercury ^b Zinc ^b	Nest box studies (including insect concentrations to estimate risk to the southwestern willow flycatcher)	Variability in the test organism response may limit the ability of the test to detect statistical differences. Confounding factors (e.g., water-quality parameters) may affect results. Mean concentrations in investigation reaches generally represent worst-case concentrations of COPECs and thus likely overestimate exposures that resulted in egg or insect concentrations or exposures to populations.

^a Based on HQ >3 using minimum ESL unless otherwise noted.

^b Based on HQ >1 using ESL for a T&E species.

Table 8.1-2
Field Studies in Pajarito Canyon Watershed as Implemented

Assay Type	Reach	Rationale for Reach Selection Based on HQ
Soil COPECs		
Earthworm Toxicity and Bioaccumulation	PA-0	Background reach
	AW-1	Worm: chromium Robin: mercury, Aroclor-1254, di-n-butylphthalate
	AEN-1	Worm: chromium, mercury Shrew: cadmium, thallium Mouse: cadmium, thallium Robin: cadmium, mercury, vanadium Perchlorate (no ESL available)
	PAS-1E	Included based on potential for toxicity to plants
	PA-1E	Worm: chromium, copper Shrew: cadmium Mouse: cadmium Robin: cadmium, copper, vanadium
	PA-4	Worm: chromium Shrew: antimony, cadmium Robin: cadmium, copper, lead, vanadium, zinc, di-n-butylphthalate
	THM-1	Worm: copper Robin: copper, lead, bis(2-ethylhexyl)phthalate
	TW-1W	Mouse: 2,3,7,8-TCDD; background reach for TCDD
	TW-1E	Worm: measured for bioaccumulation to bird receptor Shrew: Aroclor-1248 Mouse: Aroclor-1248, 2,3,7,8-TCDD Robin: lead, zinc, Aroclor-1248 Perchlorate (no ESL available)
	TWN-1E	Worm: measured for bioaccumulation to bird receptor Shrew: Aroclor-1248 Robin: zinc, Aroclor-1254, di-n-butylphthalate Perchlorate (no ESL available)
	TWSE-1W	Worm: copper Robin: cyanide
	Plant Toxicity	PA-0
AW-1		Plant: barium, vanadium
AEN-1		Plant: chromium, manganese, selenium, silver, thallium, vanadium, zinc
PAS-1E		Plant: silver
PA-1E		Plant: chromium, copper, selenium, silver, vanadium
PA-4		Plant: antimony, barium, chromium, copper, manganese, selenium, silver, vanadium, zinc
TW-1E		Plant: barium, silver, zinc
TWN-1E		Plant: manganese, zinc
TWSE-1W		Plant: copper

Table 8.1-2 (continued)

Assay Type	Reach	Rationale for Reach Selection Based on HQ
Soil COPECs (cont.)		
Plant Toxicity (cont.)	THM-1	Plant: copper. 4th lowest overall HI. Background reach PA-0 has COPECs for plants; this reach may provide better response to low concentrations of COPECs
Additional Nest Boxes (measures of reproductive success; insect and egg collection)	AW-1	Robin: mercury, Aroclor-1254, di-n-butylphthalate
	PA-1E	Robin: cadmium, mercury, vanadium
	PA-2W	Robin: cadmium, copper, total cyanide, vanadium
	PA-3E	Robin: total cyanide, lead, vanadium
	PA-4	Robin: cadmium, copper, total cyanide, lead, vanadium, zinc, di-n-butylphthalate
	TWSE-1W	Robin: cyanide
Sediment COPECs		
Additional Nest Boxes (insect collection)	AW-1	Bat: aluminum, cadmium Swallow: mercury Southwestern willow flycatcher: aluminum, cadmium, mercury, silver, vanadium, Aroclor-1254
	Upper PA-1E	Bat: no study COPECs Swallow: no study COPECs Southwestern willow flycatcher: cadmium
	PA-2W	Bat: no study COPECs Swallow: no study COPECs Southwestern willow flycatcher: no study COPECs
	PA-3E	Bat: aluminum Swallow: total cyanide Southwestern willow flycatcher: aluminum, cadmium, copper, total cyanide, lead, selenium, zinc
	PA-4	Bat: aluminum, cadmium Swallow: aluminum, total cyanide Southwestern willow flycatcher: aluminum, cadmium, copper, total cyanide, lead, vanadium, zinc
Aquatic Toxicity and Rapid Bioassessment Protocol for Aquatic Invertebrates	PA-0	Background location. Collect sediment for toxicity testing; not used for rapid bioassessment protocol
	AW-1	Aquatic community: aluminum, cadmium, iron, mercury, silver
	PAS-2E	Closest to the reach with maximum HQs for the aquatic community
	PA-4	Aquatic community: barium, total cyanide, iron, manganese
	TW-2E	Aquatic community: Aroclor-1254, Aroclor-1260

Table 8.1-3
Samples Collected from Nest Boxes

Reach/Location	Number of Egg Samples	Number of Insect Samples
AW-1	1*	2
PAS-1E	0	1
PA-2W	0	2
PA-3E	0	2
TWSE-1W	0	5
South of PA-1E, near watershed divide at top of Threemile Canyon	1	0
TA-15, R-44 firing site, between THM-1 and THS-1W	1	0

*This was a nestling, not an egg.

Table 8.1-4
Summary of Sediment and Mammal Tissue PCB and Mercury Data

Canyon	Media	COPEC	Detects			Nondetects		
			Count	Minimum	Maximum	Count	Minimum	Maximum
Mortandad	Sediment	Aroclor-1248	0	n/a*	n/a	304	0.002	0.38
	Whole mammal		0	n/a	n/a	2	0.06	0.07
	Carcass-mammal		0	n/a	n/a	13	0.05	0.08
	Pelt-mammal		0	n/a	n/a	11	0.07	0.09
Los Alamos and Pueblo	Sediment	Aroclor-1248	0	n/a	n/a	325	0.002	5.1
	Whole mammal		0			98	0.011	0.025
Pajarito	Sediment	Aroclor-1248	14	0.0118	0.637	320	0.0033	0.0872
Mortandad	Sediment	Aroclor-1254	27	0.0011	0.57	277	0.002	0.38
	Whole mammal		0	n/a	n/a	2	0.06	0.07
	Carcass-mammal		0	n/a	n/a	13	0.05	0.08
	Pelt-mammal		0	n/a	n/a	11	0.07	0.09
Los Alamos and Pueblo	Sediment	Aroclor-1254	64	0.0032	6.2	261	0.002	2.1
	Whole mammal		0	n/a	n/a	98	0.011	0.025
Pajarito	Sediment	Aroclor-1254	86	0.002	2.63	248	0.0033	0.0872
Mortandad	Sediment	Aroclor-1260	160	0.0017	1.37	143	0.002	0.31
	Whole mammal		1	0.32	0.32	1	0.06	0.06
	Carcass-mammal		1	0.06	0.06	12	0.05	0.08
	Pelt-mammal		6	0.03	0.28	5	0.07	0.09
Los Alamos and Pueblo	Sediment	Aroclor-1260	145	0.0012	3.3	180	0.0021	3.6
	Whole mammal		20	0.0037	0.12	78	0.015	0.025
Pajarito	Sediment	Aroclor-1260	100	0.0015	0.804	234	0.0033	0.0872

Table 8.1-4 (continued)

Canyon	Media	COPEC	Detects			Nondetects		
			Count	Minimum	Maximum	Count	Minimum	Maximum
Mortandad	Sediment	Mercury	610	0.00109	3.996	191	0.002	0.24
	Whole mammal		2	0.0077	0.03	0	n/a	n/a
	Carcass-mammal		6	0.01	0.02	7	0.0071	0.01
	Pelt-mammal		8	0.01	0.07	5	0.0072	0.01
Los Alamos and Pueblo	Sediment		283	0.00164	7.2	145	0.0016	0.14
	Whole mammal		37	0.0051	0.089	59	0.0046	0.042
Pajarito	Sediment		314	0.0023	1.58	51	0.0018	0.034

* n/a = Not applicable.

**Table 8.1-5
Exposure Evaluation for the Southwestern Willow Flycatcher**

COPEC	Reach	Pathway	Sample Result (mg/kg)	Sample Result Nondetects Set to Zero (mg/kg)	Pathway HQ
Aroclor-1248	AW-1	WORM	0.65	0	4.5
	TW-1E	WORM	0.34	0.34	2.3
	AEN-1	WORM	0.038	0	0.26
	PA-0	WORM	0.015	0	0.10
	PA-4	WORM	0.015	0	0.10
	TWN-1E	WORM	0.015	0	0.10
	TWSE-1W	WORM	0.015	0	0.10
	PA-1E	WORM	0.014	0	0.10
	PAS-1E	WORM	0.014	0	0.10
	THM-1	WORM	0.013	0	0.09
TW-1W	WORM	0.012	0	0.08	
Aroclor-1254	AW-1	WORM	6.5	6.5	44.7
	AEN-1	WORM	0.27	0.27	1.9
	TWN-1E	WORM	0.075	0.075	0.52
	THM-1	WORM	0.062	0.062	0.43
	TW-1E	WORM	0.042	0	0.29
	PAS-1E	WORM	0.017	0.017	0.12
	PA-0	WORM	0.015	0	0.10
	PA-4	WORM	0.015	0	0.10
	TWSE-1W	WORM	0.015	0	0.10
	PA-1E	WORM	0.014	0	0.10
TW-1W	WORM	0.012	0	0.08	

Table 8.1-5 (continued)

COPEC	Reach	Pathway	Sample Result (mg/kg)	Sample Result Nondetects Set to Zero (mg/kg)	Pathway HQ
Cadmium	AEN-1	WORM	5.7	5.7	2.3
	AW-1	WORM	2	2	0.81
	PA-1E	WORM	1.3	1.3	0.53
	THM-1	WORM	0.53	0.53	0.21
	PAS-1E	WORM	0.45	0.45	0.18
	PA-4	WORM	0.43	0.43	0.17
	TWN-1E	WORM	0.39	0.39	0.16
	TW-1E	WORM	0.36	0.36	0.15
	TW-1W	WORM	0.36	0.36	0.15
	TWSE-1W	WORM	0.28	0.28	0.11
	PA-0	WORM	0.27	0.27	0.11
	AW-1	INSECTS	7.7	7.7	3.6
	PAS-1E	INSECTS	1.2	1.2	0.56
	PA-3E	INSECTS	0.82	0.82	0.38
	TWSE-1W	INSECTS	0.33	0.33	0.15
	PA-2W	INSECTS	0.27	0.27	0.13
Mercury	AW-1	WORM	0.062	0.062	2.2
	TWN-1E	WORM	0.033	0.033	1.2
	AEN-1	WORM	0.03	0.03	1.1
	THM-1	WORM	0.015	0.015	0.54
	TW-1W	WORM	0.013	0.013	0.47
	TWSE-1W	WORM	0.01	0.01	0.36
	PA-0	WORM	0.0085	0.0085	0.31
	PA-4	WORM	0.0072	0.0072	0.26
	PA-1E	WORM	0.007	0.007	0.25
	TW-1E	WORM	0.0054	0.0054	0.20
	PAS-1E	WORM	0.0046	0.0046	0.17
Silver	AW-1	WORM	2	2	0.25
	AW-1	INSECTS	0.82	0.82	0.12
Vanadium	AEN-1	WORM	0.28	0.28	0.56
	AW-1	WORM	0.28	0.28	0.56
	AW-1	INSECTS	4.1	4.1	9.4
	PAS-1E	INSECTS	1.5	1.5	3.4
	TWSE-1W	INSECTS	1.4	1.4	3.2
	PA-3E	INSECTS	1.1	1.1	2.5
	PA-2W	INSECTS	0.39	0.39	0.90

Table 8.1-5 (continued)

COPEC	Reach	Pathway	Sample Result (mg/kg)	Sample Result Nondetects Set to Zero (mg/kg)	Pathway HQ
Zinc	PA-1E	WORM	19	1	0.35
	AW-1	WORM	18	18	0.33
	AW-1	INSECTS	5000	5000	105
	PA-3E	INSECTS	220	220	4.6
	PAS-1E	INSECTS	180	180	3.8
	PA-2W	INSECTS	100	100	2.1
	TWSE-1W	INSECTS	88	88	1.8

Note: Cells are highlighted if the HQ >1.

Table 8.1-6
Exposure Evaluation for the Bat

COPEC	Reach	Pathway	Sample Result (mg/kg)	Sample Result Nondetects Set to Zero (mg/kg)	Pathway HQ
Aroclor-1248	AW-1	WORM	0.65	0	26.9
	TW-1E	WORM	0.34	0.34	14.0
	AEN-1	WORM	0.038	0	1.6
	PA-0	WORM	0.015	0	0.6
	PA-4	WORM	0.015	0	0.6
	TWN-1E	WORM	0.015	0	0.6
	TWSE-1W	WORM	0.015	0	0.6
	PA-1E	WORM	0.014	0	0.6
	PAS-1E	WORM	0.014	0	0.6
	THM-1	WORM	0.013	0	0.5
	TW-1W	WORM	0.012	0	0.5
Cadmium	AEN-1	WORM	5.7	5.7	3.0
	AW-1	WORM	2	2	1.1
	PA-1E	WORM	1.3	1.3	0.69
	THM-1	WORM	0.53	0.53	0.28
	PAS-1E	WORM	0.45	0.45	0.24
	PA-4	WORM	0.43	0.43	0.23
	TWN-1E	WORM	0.39	0.39	0.21
	TW-1E	WORM	0.36	0.36	0.19
	TW-1W	WORM	0.36	0.36	0.19
	TWSE-1W	WORM	0.28	0.28	0.15
	PA-0	WORM	0.27	0.27	0.14
	AW-1	INSECTS	7.7	7.7	4.1
	PAS-1E	INSECTS	1.2	1.2	0.64
	PA-3E	INSECTS	0.82	0.82	0.44
TWSE-1W	INSECTS	0.33	0.33	0.18	
PA-2W	INSECTS	0.27	0.27	0.14	

Note: Cells are highlighted if the HQ > 0.1.

Table 8.1-7
Comparisons of Insect Concentrations

COPEC	Reach AW-1 Concentration (mg/kg)	Ratio AW-1 to Overall Max	Pajarito Concentration Range without Reach AW-1 (mg/kg)	2005 Concentration Range (mg/kg)*
Antimony	0.098	0.43	0.018–0.031	0.014–0.23
Cadmium	7.7	11	0.27–1.2	0.015–0.72
Copper	38	0.41	11–45	0.85–93
Lead	130	72	0.45–1.7	0.024–1.8
Thallium	0.015	0.11	0.0052–0.03	0.01–0.14
Vanadium	4.1	1.14	0.39–1.5	0.24–3.6
Zinc	5000	24	88–220	8.6–210

Note: Cells are highlighted because the value in reach AW-1 is more than 10 times larger than the next highest value.

* n=14; from Colestock (2006, 102994).

Table 8.1-8
Comparisons of Concentration Ratios to Transfer Factors

COPEC	CR Based on Measured Earthworm and Soil Concentrations			Invertebrate TF*
	Reach AW-1	Reach TW-1E	Reach AEN-1	
Antimony	0.0175	0.0091	0.0078	0.167
Cadmium	1.55	0.922	1.97	0.96
Copper	0.098	0.104	0.300	0.04
Lead	0.0162	0.0132	0.0045	0.03
Mercury	0.130	0.0359	0.245	0.04
Silver	0.0504	0.0262	0.0299	0.167
Thallium	0.0598	0.138	0.0882	0.167
Vanadium	0.0095	0.0078	0.0034	0.167
Zinc	0.237	0.307	0.318	0.56
Aroclor-1248	Not detected	Not detected	10.1	1.13
Aroclor-1254	14.1	8.06	1.28	1.13
Aroclor-1260	3.65	3.49	7.24	1.13

Note: Cells are highlighted because CR is greater than the TF.

*Converted to fresh weight based on moisture content of earthworm (83.3%).

**Table 8.1-9
Exposure Evaluation for the Robin**

COPEC	Reach	Pathway	Sample Result (mg/kg)	Sample Result Nondetects Set to Zero (mg/kg)	Pathway HQ
Aroclor-1248	AW-1	WORM	0.65	0	9.9
	TW-1E	WORM	0.34	0.34	5.2
	AEN-1	WORM	0.038	0	0.6
	PA-0	WORM	0.015	0	0.2
	PA-4	WORM	0.015	0	0.2
	TWN-1E	WORM	0.015	0	0.2
	TWSE-1W	WORM	0.015	0	0.2
	PA-1E	WORM	0.014	0	0.2
	PAS-1E	WORM	0.014	0	0.2
	THM-1	WORM	0.013	0	0.2
	TW-1W	WORM	0.012	0	0.2
	AW-1	WORM	6.5	6.5	98.8
	AEN-1	WORM	0.27	0.27	4.1
	TWN-1E	WORM	0.075	0.075	1.1
	THM-1	WORM	0.062	0.062	0.9
	TW-1E	WORM	0.042	0	0.6
	PAS-1E	WORM	0.017	0.017	0.3
	PA-0	WORM	0.015	0	0.2
	PA-4	WORM	0.015	0	0.2
	TWSE-1W	WORM	0.015	0	0.2
PA-1E	WORM	0.014	0	0.2	
TW-1W	WORM	0.012	0	0.2	
Cadmium	AW-1	INSECTS	7.7	7.7	6.9
	PAS-1E	INSECTS	1.2	1.2	1.1
	PA-3E	INSECTS	0.82	0.82	0.7
	TWSE-1W	INSECTS	0.33	0.33	0.3
	PA-2W	INSECTS	0.27	0.27	0.2
	AEN-1	WORM	5.7	5.7	5.1
	AW-1	WORM	2	2	1.8
	PA-1E	WORM	1.3	1.3	1.2
	THM-1	WORM	0.53	0.53	0.5
	PAS-1E	WORM	0.45	0.45	0.4
	PA-4	WORM	0.43	0.43	0.4
	TWN-1E	WORM	0.39	0.39	0.3
	TW-1E	WORM	0.36	0.36	0.3
	TW-1W	WORM	0.36	0.36	0.3
	TWSE-1W	WORM	0.28	0.28	0.3
PA-0	WORM	0.27	0.27	0.2	

Table 8.1-9 (continued)

COPEC	Reach	Pathway	Sample Result (mg/kg)	Sample Result Nondetects Set to Zero (mg/kg)	Pathway HQ
Copper	PA-3E	INSECTS	45	45	22.9
	AW-1	INSECTS	38	38	19.4
	PA-2W	INSECTS	25	25	12.7
	TWSE-1W	INSECTS	18	18	9.2
	PAS-1E	INSECTS	11	11	5.6
	THM-1	WORM	2.9	2.9	1.5
	PA-1E	WORM	2.1	2.1	1.1
	AW-1	WORM	1.9	1.9	1.0
	TWN-1E	WORM	1.9	1.9	1.0
	PA-4	WORM	1.8	1.8	0.9
	AEN-1	WORM	1.7	1.7	0.9
	PA-0	WORM	1.6	1.6	0.8
	TW-1E	WORM	1.4	1.4	0.7
	TW-1W	WORM	1.4	1.4	0.7
	TWSE-1W	WORM	1.4	1.4	0.7
	PAS-1E	WORM	1.3	1.3	0.7
Lead	AW-1	INSECTS	130	130	121
	PAS-1E	INSECTS	1.7	1.7	1.6
	TWSE-1W	INSECTS	1.6	1.6	1.5
	PA-3E	INSECTS	1.5	1.5	1.4
	PA-2W	INSECTS	0.45	0.45	0.4
	AW-1	WORM	0.54	0.54	0.5
Mercury	AW-1	WORM	0.062	0.062	5.0
	TWN-1E	WORM	0.033	0.033	2.6
	AEN-1	WORM	0.03	0.03	2.4
	THM-1	WORM	0.015	0.015	1.2
	TW-1W	WORM	0.013	0.013	1.0
	TWSE-1W	WORM	0.01	0.01	0.8
	PA-0	WORM	0.0085	0.0085	0.7
	PA-4	WORM	0.0072	0.0072	0.6
	PA-1E	WORM	0.007	0.007	0.6
	TW-1E	WORM	0.0054	0.0054	0.4
	PAS-1E	WORM	0.0046	0.0046	0.4

Table 8.1-9 (continued)

COPEC	Reach	Pathway	Sample Result (mg/kg)	Sample Result Nondetects Set to Zero (mg/kg)	Pathway HQ
Vanadium	AW-1	INSECTS	4.1	4.1	18.1
	PAS-1E	INSECTS	1.5	1.5	6.6
	TWSE-1W	INSECTS	1.4	1.4	6.2
	PA-3E	INSECTS	1.1	1.1	4.9
	PA-2W	INSECTS	0.39	0.39	1.7
	AEN-1	WORM	0.28	0.28	1.2
	AW-1	WORM	0.28	0.28	1.2
	TWSE-1W	WORM	0.13	0.13	0.6
	PA-1E	WORM	0.085	0.085	0.4
	PA-4	WORM	0.066	0.066	0.3
	PAS-1E	WORM	0.065	0.065	0.3
	THM-1	WORM	0.063	0.063	0.3
	TWN-1E	WORM	0.042	0.042	0.2
	TW-1E	WORM	0.039	0.039	0.2
	PA-0	WORM	0.029	0.029	0.1
	TW-1W	WORM	0.021	0.021	0.1
Zinc	AW-1	INSECTS	5000	5000	202
	PA-3E	INSECTS	220	220	8.9
	PAS-1E	INSECTS	180	180	7.3
	PA-2W	INSECTS	100	100	4.0
	TWSE-1W	INSECTS	88	88	3.5
	PA-1E	WORM	19	19	0.8
	AW-1	WORM	18	18	0.7

Note: Cells are highlighted if the HQ >1.

**Table 8.1-10
Exposure Evaluation for the Shrew**

COPEC	Reach	Pathway	Sample Result (mg/kg)	Sample Result Nondetects Set to Zero (mg/kg)	Pathway HQ
Antimony	AW-1	INSECTS	0.098	0.098	1.0
	TWSE-1W	INSECTS	0.031	0.031	0.3
	PA-3E	INSECTS	0.03	0	0.3
	PAS-1E	INSECTS	0.03	0	0.3
	PA-2W	INSECTS	0.018	0	0.2
	AW-1	WORM	0.0087	0.0087	0.1
Aroclor-1248	AW-1	WORM	0.65	0	40.7
	TW-1E	WORM	0.34	0.34	21.3
	AEN-1	WORM	0.038	0	2.4
	PA-0	WORM	0.015	0	0.9
	PA-4	WORM	0.015	0	0.9
	TWN-1E	WORM	0.015	0	0.9
	TWSE-1W	WORM	0.015	0	0.9
	PA-1E	WORM	0.014	0	0.9
	PAS-1E	WORM	0.014	0	0.9
	THM-1	WORM	0.013	0	0.8
	TW-1W	WORM	0.012	0	0.8
Cadmium	AW-1	INSECTS	7.7	7.7	6.2
	PAS-1E	INSECTS	1.2	1.2	1.0
	PA-3E	INSECTS	0.82	0.82	0.7
	TWSE-1W	INSECTS	0.33	0.33	0.3
	PA-2W	INSECTS	0.27	0.27	0.2
	AEN-1	WORM	5.7	5.7	4.6
	AW-1	WORM	2	2	1.6
	PA-1E	WORM	1.3	1.3	1.0
	THM-1	WORM	0.53	0.53	0.4
	PAS-1E	WORM	0.45	0.45	0.4
	PA-4	WORM	0.43	0.43	0.3
	TWN-1E	WORM	0.39	0.39	0.3
	TW-1E	WORM	0.36	0.36	0.3
	TW-1W	WORM	0.36	0.36	0.3
	TWSE-1W	WORM	0.28	0.28	0.2
PA-0	WORM	0.27	0.27	0.2	

Table 8.1-10 (continued)

COPEC	Reach	Pathway	Sample Result (mg/kg)	Sample Result Nondetects Set to Zero (mg/kg)	Pathway HQ
Thallium	PA-3E	INSECTS	0.03	0	2.6
	TWSE-1W	INSECTS	0.019	0.019	1.7
	AW-1	INSECTS	0.015	0	1.3
	PAS-1E	INSECTS	0.012	0	1.0
	PA-2W	INSECTS	0.0052	0	0.5
	AEN-1	WORM	0.45	0.45	39.3
	PA-1E	WORM	0.022	0.022	1.9
	TWN-1E	WORM	0.017	0.017	1.5
	PA-0	WORM	0.014	0.014	1.2
	PA-4	WORM	0.012	0.012	1.0
	TW-1E	WORM	0.012	0.012	1.0
	AW-1	WORM	0.011	0.011	1.0
	PAS-1E	WORM	0.01	0.01	0.9
	TW-1W	WORM	0.0088	0.0088	0.8
	TWSE-1W	WORM	0.008	0.008	0.7
	THM-1	WORM	0.006	0.006	0.5

Note: Cells are highlighted if the HQ >1.

**Table 8.1-11
Habitat Assessment Scores**

Parameter	Reach ID		
	PA-4	PAS-2E	TW-2E
Epifaunal Substrate & Cover	—*	12	12
Embeddedness	—	12	12
Velocity/Depth Regime	—	14	8
Sediment Deposition	—	9	10
Channel Flow Status	—	18	8
Channel Alteration	—	20	20
Frequency of Riffles	—	20	16
Bank Stability - Left Bank	—	5	6
Bank Stability - Right Bank	—	5	8
Vegetative Bank Protection - Left Bank	—	6	9
Vegetative Bank Protection - Right Bank	—	8	9
Riparian Vegetative Zone - Left Bank	—	10	10
Riparian Vegetative Zone - Right Bank	—	10	10
Habitat Assessment Score	—	149 – Suboptimal	138 – Suboptimal

Note: Values from Henne (2008, 102991), indicating the score for each parameter in each reach and the total score possible for that parameter.

*— = Not applicable for a wetland site.

**Table 8.1-12
Macroinvertebrate Sample Abundance and Number of Taxa**

Taxonomic Measure	Reach ID		
	PA-4	PAS-2E	TW-2E
Percent of Sample Processed	100%	75%	100%
Number of Individuals Identified	274	203	131
Estimated Total Number of Individuals in Entire Sample	274	271	131
Number of Tolerant Individuals (tolerance value greater than 7)	256	2	19
Number of Taxa	12	12	20
Number of Tolerant Taxa (tolerance value greater than 7)	9	2	6

**Table 8.1-13
Lines of Evidence and Rationale for the Mexican Spotted Owl (AE1)**

Line of Evidence	Weight of Evidence Criteria	Result
(1) Measured concentrations in prey species (small mammals)—review prey COPEC concentrations from Los Alamos and Pueblo Canyons and Mortandad watershed	High	Dose of COPEC ingested had HQ <1.0 for all COPECs when compared with TRV, indicating that the risk through food ingestion was much lower than that predicted by the ESL.
(2) Modeled exposure and literature toxicity information to calculate spatially weighted HQ values using ECORSK.9 (includes consideration of nesting and foraging habitat based on vegetation class coverage)	Medium	Total mean adjusted HI across watershed for owl equals 0.1, indicating no potential for adverse effects.
(3) Comparison of concentrations in sediment samples to ESLs	Low	Screening of sediment data against ESLs identified study design COPECs and the potential for adverse effects on this receptor.

**Table 8.1-14
Lines of Evidence and Rationale for Avian and Mammalian Aerial Insectivores (AE6)**

Line of Evidence	Weight of Evidence Criteria	Result	Aerial Insectivore Receptors
(1) Nest box study—Determine nest success rate by bluebirds along a gradient of COPEC concentrations in the Pajarito watershed	Medium (new boxes)	Percent fledged and percent female nestlings were not different between Pajarito watershed reaches or between Pajarito watershed and reference sites, indicating no effect on population (measured as nest success).	Southwestern willow flycatcher/violet-green swallow
(2) Nest box study—Determine eggshell thickness for bluebirds along a gradient of COPEC concentrations in Pajarito watershed	Medium	Egg size (length and weight) and eggshell thickness were not different between Pajarito reaches or between Pajarito and reference locations, indicating no effect on nest success.	Southwestern willow flycatcher/violet-green swallow
(3) Nest box study—Compare COPEC concentrations in eggs within Pajarito watershed and also compare concentrations with “reference” locations	Medium-low	Uncertain; no eggs were sampled in Pajarito reaches.	Southwestern willow flycatcher/violet-green swallow
(4) Compare the measured concentrations of COPECs in insects with the TRV	Medium	Potential dose through food to southwestern willow flycatcher and little myotis bat modeled was based on measured COPEC concentrations in nest box insects and earthworms. PCB mixtures and metals had HQ >1 in selected reaches.	Southwestern willow flycatcher/violet-green swallow Occult little myotis bat

Table 8.1-14 (continued)

Line of Evidence	Weight of Evidence Criteria	Result	Aerial Insectivore Receptors
(5) Modeled exposure and literature toxicity information to calculate spatially weighted HQ values using ECORSK.9 (includes consideration of nesting and foraging habitat based on vegetation class coverage)—could be based on a frequency of HQ values greater than 1 for the watershed	Medium	The mean adjusted total HI for the southwestern willow flycatcher was 2.3, based on Aroclor-1254 and inorganic chemicals. These values indicate a potential for risk to the flycatcher.	Southwestern willow flycatcher
(6) Comparison of concentrations in sediment and water samples to ESLs	Low	Screening of sediment data against ESLs identified study design COPECs and the potential for adverse effects on this receptor.	Southwestern willow flycatcher/violet-green swallow Occult little myotis bat

**Table 8.1-15
Lines of Evidence and Rationale for Avian Ground Invertevores (AE2)**

Line of Evidence	Weight of Evidence Criteria	Result
(1) Nest box study-Compare the measured concentrations of COPECs in insects with the TRV for the robin with the invertevore diet	Medium	Exposure through food to robin was evaluated based on measured COPEC concentrations in nest box insects. Metals had HQ >1 in selected reaches.
(2) Nest box study—Determine nest success rate by bluebirds along a gradient of COPEC concentrations in the Pajarito watershed	Medium (new boxes)	Percent fledged and percent female nestlings were not different between Pajarito watershed reaches or between Pajarito watershed and reference sites, indicating no effect on population (measured as nest success).
(3) Nest box study—Determine eggshell thickness for bluebirds along a gradient of COPEC concentrations in Pajarito watershed	Medium	Egg size (length and weight) and eggshell thickness were not different between Pajarito reaches or between Pajarito and reference locations, indicating no effect on nest success.
(4) Nest box study—Compare COPEC concentrations in eggs within Pajarito watershed and also compare concentrations with “reference” locations	Medium-low	Uncertain; no eggs were sampled in Pajarito reaches

Table 8.1-15 (continued)

Line of Evidence	Weight of Evidence Criteria	Result
(5) Modeled and measured concentrations in food (earthworm bioaccumulation test)—Determine if exposure concentrations differ within the watershed in relation to sediment concentrations; design used a gradient in COPEC concentrations with the Pajarito watershed and also compared concentrations with “reference” locations	Medium	HQs based on concentrations in earthworms indicated that some COPECs may have potential for ecological risk to avian ground invertevores.
(6) Comparison of concentrations in sediment samples to ESLs	Low	Screening of sediment data against ESLs identified study design COPECs and the potential for adverse effects on this receptor.

Table 8.1-16

Lines of Evidence and Rationale for Mammalian Invertevores and Omnivores (AE3)

Line of Evidence	Weight of Evidence Criteria	Result
(1) Modeled and measured concentrations in food (earthworms)—Could determine if exposure concentrations differ within the watershed in relation to sediment concentrations; design could use a gradient in COPEC concentrations with the Pajarito watershed and also compare concentrations with “reference” location	Medium	The exposure evaluation for the shrew or mouse using concentrations in earthworms or insects showed Aroclor-1248, cadmium, and thallium with HQ large enough to indicate potential for adverse effects. Because high HQ >3 were observed in two reaches (AEN-1 and TW-1E) the potential for population effects is low.
(2) Comparison of concentrations in sediment samples to ESLs	Low	Screening of sediment data against ESLs identified study design COPECs and the potential for adverse effects on this receptor.

Table 8.1-17
Lines of Evidence and Rationale for Detritivores (AE4)

Line of Evidence	Weight of Evidence Criteria	Result
(1) Toxicity test (earthworm mortality) along gradient of COPEC concentrations in the Pajarito watershed and Los Alamos and Pueblo watershed —Compare mortality rates with “reference” locations	High	No differences in earthworm mortality were seen between reaches, indicating no effect along COPEC gradient. Weight loss differed between reaches but did not correlate with COPEC concentrations.
(2) The concentration of COPECs in earthworms	Contributor to other AEs	Bioaccumulation was measured for PCB mixtures and inorganic chemicals, which suggests the potential for exposure.
(3) Comparison of concentrations in sediment samples to ESLs	Low	Screening of sediment data against ESLs identified study design COPECs and the potential for adverse effects on this receptor.

Table 8.1-18
Lines of Evidence and Rationale for Plants (AE5)

Line of Evidence	Weight of Evidence Criteria	Result
(1) Toxicity test (seedling germination) along gradient of COPEC concentrations in the Pajarito watershed and also compare germination rates with “reference” locations	High	No differences in mortality or shoot mass. There were some differences in root mass between reaches but differences did not correlate with COPEC concentration.
(2) Comparison of concentrations in sediment samples to ESLs	Low	Screening of sediment data against ESLs identified study design COPECs and the potential for adverse effects on this receptor.

**Table 8.1-19
Lines of Evidence and Rationale for the Aquatic Community (AE7)**

Line of Evidence	Weight of Evidence Criteria	Result
(1) Estimates of growth and mortality of aquatic invertebrates based on toxicity tests using <i>Chironomus tentans</i> compared with the reference location	High	There were no significant differences in larval survival between reaches. Differences in growth were correlated to particle size and not COPECs. Thus, there are no adverse effect of COPECs on larval survival and growth.
(2) A rapid bioassessment characterization to evaluate habitat ratings at selected locations based on watershed features, riparian vegetation, in-stream features, aquatic vegetation, and benthic substrate; assessment will also include measures of abundance and diversity of aquatic invertebrates through Hess sampling and dip net capture	Medium	Physical aspects of habitat similar between reaches; all rated as marginal using index scores. Chironomids made up majority of biomass in all reaches, supporting their use as toxicity indicator organism.
(3) Comparison of concentrations in sediment and water samples to ESLs	Low	Screening of sediment data against ESLs identified study design COPECs and the potential for adverse effects on this receptor.

**Table 8.2-1
Residential Risk Ratios Used to Identify Sediment COPCs, Noncarcinogens**

Reach	Aluminum	Antimony	Barium	Beryllium	Cadmium	Cobalt	Copper	Cyanide (Total)	Iron	Lead	Manganese	Mercury (1)	Nickel	Nitrate	Perchlorate (1)	Selenium	Silver	Thallium	Uranium (Calculated Total) (1)
Residential SSL (mg/kg)	77800	31.3	15600	156	39	1520	3130	1220	23500	400	3590	23	1560	100000	55	391	391	5.16	16
Endpoint	nc	nc	nc	nc	nc	nc	nc	nc	nc	nc	nc	nc	nc	max	nc	nc	nc	nc	nc
AEN-1	0.27	--*	0.014	--	0.122	<0.010	<0.010	--	0.68	0.056	0.22	0.031	<0.010	--	<0.010	<0.010	0.017	0.331	0.55
AES-1	0.26	--	0.011	--	--	<0.010	--	--	0.65	0.066	0.22	--	--	--	--	--	--	--	--
AW-1	0.44	--	0.056	<0.010	0.093	<0.010	0.013	--	1.1	0.193	0.19	0.069	<0.010	--	--	<0.010	0.14	--	0.65
PA-0	--	--	0.015	--	--	<0.010	--	<0.010	--	--	0.19	--	--	--	<0.010	0.011	--	--	--
PA-1E	--	--	--	--	0.100	<0.010	0.016	--	--	0.054	0.19	--	0.031	--	<0.010	<0.010	0.043	--	--
PA-1W	0.20	--	<0.010	--	--	<0.010	--	--	--	--	--	--	--	--	<0.010	--	--	--	--
PA-2W	0.27	--	0.013	--	0.038	<0.010	0.029	<0.010	0.68	--	0.18	--	0.026	--	<0.010	<0.010	0.019	--	0.58
PA-3E	0.21	--	0.028	--	0.013	<0.010	<0.010	<0.010	--	0.182	0.41	--	<0.010	--	<0.010	<0.010	--	--	--
PA-4	0.42	0.0304	0.047	<0.010	0.026	<0.010	0.012	<0.010	1.0	0.121	0.64	--	0.011	<0.010	--	0.010	<0.010	--	--
PA-4E	--	--	0.012	--	--	--	--	<0.010	--	--	--	--	--	--	--	<0.010	--	--	--
PA-5W	0.45	--	0.033	0.011	0.026	<0.010	<0.010	<0.010	1.02	0.088	0.35	--	0.012	--	--	<0.010	--	--	--
PAS-1E	0.23	--	0.013	--	0.020	<0.010	--	<0.010	0.98	0.053	0.23	--	--	--	--	<0.010	0.11	--	--
PAS-2W	--	--	0.025	--	0.012	<0.010	--	--	--	--	--	--	--	--	--	--	0.077	--	--
TH-1C	--	--	0.011	--	--	<0.010	--	--	0.82	--	0.52	--	--	--	--	<0.010	--	--	0.91
TH-1E	0.37	--	0.017	--	--	0.010	<0.010	--	0.98	--	0.42	--	<0.010	--	--	--	--	--	1.2
TH-3	--	--	--	--	--	--	--	--	--	--	--	--	--	--	--	<0.010	--	--	1.7
THM-1	--	--	<0.010	0.041	0.011	--	0.027	--	0.60	0.212	--	--	--	--	--	--	--	--	9.6
THS-1E	--	--	<0.010	--	--	--	<0.010	--	0.68	--	--	--	--	--	<0.010	--	--	--	3.8
THS-1W	--	--	--	--	--	--	<0.010	--	--	--	--	--	--	--	--	--	--	--	8.6
THW-1	0.24	--	0.013	--	0.013	<0.010	<0.010	--	--	--	0.15	--	--	--	--	--	--	--	1.5
TW-1E	--	--	0.039	--	--	--	--	--	--	0.164	--	--	--	--	<0.010	--	0.080	--	--
TW-1W	--	--	0.015	--	0.011	--	--	--	0.62	0.062	0.26	--	--	--	<0.010	<0.010	--	--	--
TW-2E	--	--	<0.010	--	0.051	--	--	--	1.0	0.058	0.17	--	--	--	--	<0.010	--	--	--
TW-3E	--	--	--	--	0.011	--	--	<0.010	--	--	--	--	--	--	<0.010	<0.010	--	--	--

Table 8.2-1 (continued)

Reach	Aluminum	Antimony	Barium	Beryllium	Cadmium	Cobalt	Copper	Cyanide (Total)	Iron	Lead	Manganese	Mercury (1)	Nickel	Nitrate	Perchlorate (1)	Selenium	Silver	Thallium	Uranium (Calculated Total) (1)
TW-4E	--	--	--	--	--	--	--	--	--	--	--	--	--	--	<0.010	<0.010	--	--	0.52
TW-4W	--	--	--	--	--	--	--	--	--	0.058	0.16	--	--	--	--	<0.010	--	--	--
TWN-1E	--	--	0.018	--	0.011	<0.010	<0.010	<0.010	--	0.066	0.28	--	--	--	<0.010	--	--	--	--
TWN-1W	--	--	<0.010	--	--	--	<0.010	--	--	0.105	0.17	--	--	--	<0.010	<0.010	--	--	--
TWSE-1E	0.23	--	<0.010	--	--	<0.010	<0.010	--	0.75	--	0.33	--	--	--	<0.010	<0.010	--	--	--
TWSE-1W	0.26	--	0.010	<0.010	--	<0.010	0.031	<0.010	0.73	--	--	--	<0.010	--	--	<0.010	--	--	--
TWSW-1E	0.21	--	0.017	--	0.011	<0.010	<0.010	<0.010	--	0.089	0.41	--	--	--	--	<0.010	--	--	0.70
TWSW-1W	0.27	--	<0.010	--	--	<0.010	--	<0.010	0.73	--	--	--	<0.010	--	--	<0.010	--	--	--

Table 8.2-1 (continued)

Reach	Vanadium	Zinc	Acenaphthene	Acenaphthylene (2)	Acetone	Amino-2,6-dinitrotoluene[4-] (3)	Amino-4,6-dinitrotoluene[2-] (3)	Anthracene	Aroclor-1242	Aroclor-1248	Aroclor-1254	Aroclor-1260	Benzoic Acid (1)	Butanone[2-]	Butylbenzene[n-]	Butylbenzylphthalate (1)	Carbon Disulfide (1)	Chloro-3-methylphenol[4-] (4)	Chloronaphthalene[2-]
Residential SSL (mg/kg)	78.2	23500	3730	2290	28100	61	61	22000	1.12	1.12	1.12	1.12	100000	31800	62.1	240	460	166	3990
Endpoint	nc	nc	nc	nc	nc	nc	nc	nc	nc	nc	nc	nc	nc	nc	sat	nc	sat	nc	nc
AEN-1	0.55	<0.010	--	--	<0.010	--	--	<0.010	--	--	--	0.10	--	<0.010	--	--	--	--	--
AES-1	0.40	--	<0.010	--	<0.010	--	--	--	--	--	--	--	--	--	--	--	--	--	--
AW-1	1.10	<0.010	<0.010	<0.010	--	--	--	<0.010	--	--	2.3	0.72	<0.010	--	--	--	<0.010	--	--
PA-0	0.41	--	--	--	--	0.0141	<0.010	--	--	--	--	--	<0.010	--	--	--	--	--	--
PA-1E	0.28	--	--	--	--	--	--	--	--	--	--	<0.010	--	--	--	--	--	--	--
PA-1W	0.33	--	--	--	--	--	--	--	--	--	<0.010	<0.010	--	--	--	--	--	--	--
PA-2W	0.33	--	--	--	<0.010	--	--	--	--	--	<0.010	<0.010	--	<0.010	--	--	--	--	--
PA-3E	0.27	<0.010	--	--	--	--	--	<0.010	--	--	0.033	<0.010	--	--	--	--	--	--	--
PA-4	0.46	<0.010	<0.010	--	<0.010	--	--	<0.010	--	--	--	0.032	--	<0.010	--	--	--	--	--
PA-4E	--	--	--	--	--	<0.010	--	--	--	--	--	--	<0.010	--	--	--	--	--	--
PA-5W	0.51	<0.010	<0.010	<0.010	--	--	--	<0.010	0.023	0.011	0.031	0.016	--	--	--	--	<0.010	--	--
PAS-1E	0.53	<0.010	--	--	--	--	--	<0.010	--	--	<0.010	<0.010	--	--	--	--	--	--	--
PAS-2W	0.31	--	<0.010	--	<0.010	--	--	<0.010	--	--	<0.010	--	<0.010	<0.010	--	--	--	<0.010	<0.010
TH-1C	--	<0.010	--	--	--	--	--	--	--	--	--	--	--	--	--	--	--	--	--
TH-1E	0.45	--	--	--	--	--	--	--	--	--	--	--	<0.010	--	--	--	--	--	--
TH-3	--	--	--	--	--	<0.010	--	--	--	--	--	--	--	--	--	--	--	--	--
THM-1	--	--	--	--	<0.010	--	--	--	--	--	0.036	0.023	<0.010	--	--	--	--	--	--
THS-1E	--	--	--	--	--	--	--	--	--	--	--	--	<0.010	--	--	--	--	--	--
THS-1W	--	--	--	--	--	--	--	--	--	--	--	--	--	--	<0.010	--	<0.010	--	--
THW-1	0.34	--	--	--	--	--	--	--	--	--	--	--	--	--	--	--	--	--	--
TW-1E	--	<0.010	--	--	<0.010	--	--	--	--	0.57	--	0.029	<0.010	--	--	--	--	--	--
TW-1W	--	--	--	--	--	--	--	--	--	--	--	<0.010	--	--	--	<0.010	<0.010	--	--
TW-2E	0.30	<0.010	<0.010	--	--	--	--	<0.010	--	0.27	0.12	0.11	--	--	--	--	--	--	--
TW-3E	--	--	<0.010	--	--	--	--	<0.010	--	--	0.049	0.043	--	--	--	--	<0.010	--	--

Table 8.2-1 (continued)

Reach	Vanadium	Zinc	Acenaphthene	Acenaphthylene (2)	Acetone	Amino-2,6-dinitrotoluene[4-] (3)	Amino-4,6-dinitrotoluene[2-] (3)	Anthracene	Aroclor-1242	Aroclor-1248	Aroclor-1254	Aroclor-1260	Benzoic Acid (1)	Butanone[2-]	Butylbenzene[n-]	Butylbenzylphthalate (1)	Carbon Disulfide (1)	Chloro-3-methylphenol[4-] (4)	Chloronaphthalene[2-]
TW-4E	--	--	--	--	<0.010	--	--	<0.010	--	--	0.029	0.018	--	<0.010	--	--	--	--	--
TW-4W	--	<0.010	--	--	--	--	--	<0.010	--	--	0.052	0.036	--	--	--	--	--	--	--
TWN-1E	--	<0.010	<0.010	--	<0.010	--	--	<0.010	--	0.052	0.16	0.15	<0.010	--	--	--	--	--	--
TWN-1W	0.25	<0.010	--	--	--	--	--	--	--	--	--	--	--	--	--	--	--	--	--
TWSE-1E	0.32	--	<0.010	--	--	--	--	<0.010	--	--	0.015	<0.010	<0.010	--	--	--	--	--	--
TWSE-1W	0.47	--	--	--	--	--	--	--	--	--	--	0.030	--	--	--	--	--	--	--
TWSW-1E	0.29	<0.010	--	--	--	--	<0.010	--	--	--	<0.010	--	--	--	--	--	--	--	--
TWSW-1W	0.40	--	--	--	--	--	--	<0.010	<0.010	--	<0.010	<0.010	--	--	--	--	--	--	--

Table 8.2-1 (continued)

Reach	Dichloroethene[1,1-]	Di-n-butylphthalate	Dinitrotoluene[2,4-]	Dinitrotoluene[2,6-] (1)	Ethylbenzene	Fluoranthene	Fluorene	HMX	Isopropyltoluene[4-] (6)	Methyl-2-pentanone [4-]	Methylnaphthalene[2-]	Methylphenol[4-] (5)	Naphthalene	Nitrobenzene	Nitrophenol[2-]	Nitrotoluene[3-]	Phenanthrene	Phenol	Pyrene	Pyridine (1)	Styrene	TATB (7)	Tetryl (5)	Toluene	Trichloroethane[1,1,1-]	Trimethylbenzene[1,2,4-]	Trimethylbenzene[1,3,5-]	Trinitrotoluene[2,4,6-]	Xylenes[1,2-]	Xylenes[1,3-]+Xylenes[1,4-] (8)	SOF	
SSL (mg/kg)	206	6110	122	61	128	2290	2660	3060	271	5510	79.5	3100	79.5	22.8	166	569	1830	18300	2290	61	100	30.6	240	252	563	58	24.8	30.6	82	\		
Endpoint	nc	nc	nc	nc	sat	nc	nc	nc	nc	nc	nc	nc	nc	nc	nc	sat	nc	nc	nc	nc	sat	nc	nc	sat	sat	nc	nc	nc	nc	sat	sat	
AEN-1	--	--	--	--	--	<0.010	--	<0.010	<0.010	--	<0.010	--	--	--	--	--	<0.010	--	<0.010	--	--	0.14	--	<0.010	--	--	--	--	--	--	3.1	
AES-1	<0.010	--	--	--	--	<0.010	--	--	<0.010	--	<0.010	--	--	--	--	--	<0.010	--	<0.010	--	--	--	--	<0.010	--	--	--	--	--	--	1.6	
AW-1	--	<0.010	--	--	--	<0.010	<0.010	--	--	--	<0.010	<0.010	<0.010	--	--	--	<0.010	<0.010	<0.010	--	--	--	--	--	--	--	--	--	--	--	7.1	
PA-0	--	--	--	--	--	--	--	<0.010	--	--	--	<0.010	--	<0.010	--	--	--	<0.010	--	0.016	--	--	<0.010	--	--	--	--	--	--	--	0.68	
PA-1E	--	--	--	--	--	<0.010	--	--	--	--	--	--	<0.010	--	--	--	<0.010	--	<0.010	--	--	0.023	--	--	--	--	--	--	--	--	0.75	
PA-1W	--	--	--	--	--	<0.010	--	--	<0.010	<0.010	--	--	--	--	--	--	<0.010	--	<0.010	--	--	--	--	--	--	--	--	--	--	<0.010	0.55	
PA-2W	--	--	--	--	--	<0.010	--	--	<0.010	<0.010	--	--	--	--	--	--	<0.010	--	<0.010	--	--	0.018	--	<0.010	--	<0.010	--	<0.010	--	<0.010	2.2	
PA-3E	--	--	--	--	--	<0.010	--	--	--	--	--	--	--	--	--	--	<0.010	--	<0.010	--	--	0.010	--	--	--	--	--	--	--	--	1.2	
PA-4	--	<0.010	--	--	--	<0.010	<0.010	--	<0.010	--	--	--	--	--	--	--	<0.010	--	<0.010	--	--	--	--	--	--	--	--	--	--	--	2.8	
PA-4E	--	--	--	--	--	--	--	--	--	--	--	--	--	--	--	--	--	<0.010	--	<0.010	--	--	<0.010	--	--	--	--	--	--	--	0.024	
PA-5W	--	--	--	--	--	<0.010	<0.010	--	--	--	--	--	--	--	--	--	<0.010	--	<0.010	--	--	--	--	--	--	--	--	--	--	--	2.6	
PAS-1E	--	--	--	--	--	<0.010	--	<0.010	--	--	<0.010	--	--	--	--	--	<0.010	--	<0.010	--	--	--	--	--	--	--	--	--	--	--	2.2	
PAS-2W	<0.010	--	--	--	<0.010	<0.010	<0.010	--	<0.010	--	<0.010	--	<0.010	--	<0.010	--	<0.010	--	<0.010	--	--	--	--	<0.010	--	<0.010	--	--	<0.010	<0.010	0.44	
TH-1C	--	--	--	--	--	--	--	--	<0.010	--	--	--	--	--	--	--	--	--	--	--	--	--	--	<0.010	--	--	--	--	--	--	2.3	
TH-1E	--	--	--	--	--	<0.010	--	--	--	--	--	--	--	--	--	--	--	--	<0.010	--	--	--	--	<0.010	--	--	--	--	--	--	3.5	
TH-3	--	--	--	<0.010	--	--	--	--	--	--	--	--	--	--	--	--	--	--	--	--	--	--	<0.010	--	--	--	--	--	--	--	1.7	
THM-1	--	--	--	--	--	<0.010	--	--	<0.010	--	--	--	--	--	--	--	<0.010	--	<0.010	--	--	--	--	<0.010	--	--	--	--	--	--	11	
THS-1E	--	--	--	--	<0.010	<0.010	--	--	--	--	--	--	--	--	--	--	<0.010	--	<0.010	--	--	--	--	<0.010	--	<0.010	--	--	<0.010	<0.010	4.5	
THS-1W	--	--	--	--	--	--	--	--	--	--	--	--	--	--	--	--	--	--	<0.010	--	--	--	--	--	--	--	<0.010	--	--	--	8.7	
THW-1	--	--	--	--	--	--	--	--	--	--	--	--	--	--	--	--	--	--	--	--	--	--	<0.010	<0.010	--	--	--	--	--	2.3		
TW-1E	<0.010	--	--	--	<0.010	<0.010	--	--	<0.010	--	--	--	--	--	--	--	<0.010	--	<0.010	--	--	--	--	<0.010	--	<0.010	--	--	<0.010	<0.010	0.89	
TW-1W	<0.010	--	--	--	--	--	--	--	<0.010	--	--	--	--	--	--	--	--	--	--	--	--	--	--	<0.010	--	--	--	--	--	--	0.97	
TW-2E	--	--	<0.010	--	--	<0.010	<0.010	--	--	--	--	--	--	--	--	<0.010	<0.010	--	<0.010	--	--	--	<0.010	--	--	--	--	--	--	--	2.1	

Table 8.2-1 (continued)

Reach	Dichloroethene[1,1-]	Di-n-butylphthalate	Dinitrotoluene[2,4-]	Dinitrotoluene[2,6-] (1)	Ethylbenzene	Fluoranthene	Fluorene	HMX	Isopropyltoluene[4-] (6)	Methyl-2-pentanone[4-]	Methylnaphthalene[2-]	Methylphenol[4-] (5)	Naphthalene	Nitrobenzene	Nitrophenol[2-]	Nitrotoluene[3-]	Phenanthrene	Phenol	Pyrene	Pyridine (1)	Styrene	TATB (7)	Tetryl (5)	Toluene	Trichloroethane[1,1,1-]	Trimethylbenzene[1,2,4-]	Trimethylbenzene[1,3,5-]	Trinitrotoluene[2,4,6-]	Xylene[1,2-]	Xylene[1,3-]+Xylene[1,4-] (8)	SOF
TW-3E	--	--	--	--	--	<0.010	--	--	--	<0.010	<0.010	--	--	--	--	--	<0.010	--	<0.010	--	--	--	--	<0.010	<0.010	--	--	--	--	--	0.11
TW-4E	--	--	--	--	--	<0.010	--	--	<0.010	<0.010	--	--	--	--	--	--	<0.010	--	<0.010	--	--	--	--	<0.010	--	<0.010	--	--	--	<0.010	0.57
TW-4W	--	--	--	--	--	<0.010	<0.010	--	--	--	--	--	--	--	--	--	<0.010	--	<0.010	--	--	--	--	--	--	--	--	--	--	--	0.31
TWN-1E	<0.010	<0.010	--	--	<0.010	0.038	0.010	--	--	--	<0.010	--	0.54	--	--	--	0.063	--	0.037	--	--	--	--	<0.010	--	<0.010	--	--	<0.010	<0.010	1.5
TWN-1W	--	--	--	--	--	--	--	--	<0.010	--	--	--	--	--	--	--	--	--	--	--	<0.010	--	--	--	--	--	--	--	--	--	0.54
TWSE-1E	--	--	--	--	--	<0.010	--	--	--	--	--	--	--	--	--	--	<0.010	--	<0.010	--	--	--	--	<0.010	--	<0.010	--	--	--	<0.010	1.7
TWSE-1W	--	--	--	--	--	<0.010	--	--	<0.010	<0.010	--	--	--	--	--	--	<0.010	--	<0.010	--	--	--	--	<0.010	--	--	--	--	--	<0.010	1.6
TWSW-1E	--	--	--	--	--	--	--	--	--	--	--	--	--	--	--	--	--	--	<0.010	--	--	--	--	--	--	--	--	--	--	--	1.7
TWSW-1W	--	--	--	--	--	<0.010	--	--	--	--	--	--	--	--	--	--	<0.010	--	<0.010	--	--	--	--	--	--	--	--	--	--	--	1.4

Notes: Residential SSL are from NMED 2006, unless otherwise noted. Ratios in bold and grey shading show where the SOF nc >1 and/or the individual COPC ratio is >0.1. COPCs and reaches shaded grey are those retained for the risk assessment. All values from EPA Region 6 HHMSLs and Region 9 preliminary remediation goals (PRGs) adjusted to TR 10⁻⁵. EPA Region 9 PRGs: (<http://www.epa.gov/region09/waste/sfund/prg/files/04prgtable.pdf>). EPA Region 6 SSLs (2007, 101002), NMED SSLs (2006, 92513). The following numbers are used in this table: 1 = USEPA Region 6 SSLs; 2 = pyrene surrogate, NMED SSLs; 3 = 2,6-dinitrotoluene surrogate, Region 6 SSLs; 4 = 2-chlorophenol surrogate, NMED SSLs; 5 = USEPA Region 9 PRG; 6 = isopropylbenzene (cumene) surrogate, Region 6 SSLs; 7 = TNT surrogate, NMED SSLs; 8 = xylenes (total) surrogate, NMED SSLs. nc = Noncarcinogen. sat = Concentration at saturation limit in soil.

*-- = Maximum concentration less than background, all results were nondetect, or no data was available.

**Table 8.2-2
Residential Risk Ratios Used to Identify Sediment COPCs, Carcinogens**

Reach	Arsenic	Chromium (1)	Aniline (1)	Aroclor-1242 ^a	Aroclor-1248 ^a	Aroclor-1254 ^a	Aroclor-1260 ^a	Benzo(a)anthracene	Benzo(a)pyrene	Benzo(b)fluoranthene	Benzo(g,h,i)perylene	Benzo(k)fluoranthene	BHC[alpha-]	BHC[beta-]	BHC[gamma-]	Bis(2-chloroethyl)ether	Bis(2-ethylhexyl)phthalate	Chlordane[alpha-] (2)	Chlordane[gamma-] (2)	Chloroform
Residential SSL (mg/kg)	3.9	2100	850	2.2	2.2	2.2	2.2	6.21	0.621	6.21	2290	62.1	0.902	3.16	4.37	2.44	347	16.2	16.2	4
Endpoint	ca	ca	ca	ca	ca	ca	ca	ca	ca	ca	ca	ca	ca	ca	ca	ca	ca	ca	ca	ca
AEN-1	1.7	0.011	<0.010	-- ^c	--	--	0.052	<0.010	0.82	--	<0.010	--	--	--	--	--	--	<0.010	<0.010	--
AES-1	1.5	<0.010	--	--	--	--	--	<0.010	--	--	--	--	--	--	--	--	--	--	--	--
AW-1	5.1	0.034	--	--	--	1.2	0.37	0.11	1.1	0.16	<0.010	<0.010	--	--	--	--	<0.010	--	--	--
PA-0	--	--	--	--	--	--	--	--	--	--	--	--	--	--	--	--	--	--	--	<0.010
PA-1E	1.1	0.011	--	--	--	--	<0.010	--	--	--	--	--	--	--	--	--	--	--	--	--
PA-1W	--	<0.010	--	--	--	<0.010	<0.010	<0.010	--	--	--	--	--	--	--	--	--	--	--	<0.010
PA-2W	--	<0.010	--	--	--	<0.010	<0.010	<0.010	--	--	--	--	--	--	--	--	--	--	--	<0.010
PA-3E	--	<0.010	--	--	--	0.017	<0.010	0.027	0.20	0.023	--	--	--	--	--	0.10	--	--	--	<0.010
PA-4	1.9	<0.010	--	--	--	--	0.016	0.027	0.22	0.035	<0.010	--	--	--	--	--	<0.010	--	--	--
PA-4E	--	--	--	--	--	--	--	--	--	--	--	--	--	<0.010	--	--	--	--	--	--
PA-5W	1.5	0.0104	--	0.012	<0.010	0.016	<0.010	0.019	0.15	--	<0.010	--	--	--	--	--	--	--	--	--
PAS-1E	2.0	<0.010	--	--	--	<0.010	<0.010	0.019	0.078	--	<0.010	--	--	--	--	--	--	--	--	--
PAS-2W	1.1	--	--	--	--	<0.010	--	0.034	0.34	--	<0.010	--	--	--	--	--	--	--	--	--
TH-1C	1.1	--	--	--	--	--	--	--	--	--	--	--	--	--	--	--	--	--	--	<0.010
TH-1E	1.9	<0.010	--	--	--	--	--	<0.010	--	--	--	--	--	--	--	--	--	--	--	--
TH-3	--	--	--	--	--	--	--	--	--	--	--	--	--	--	--	--	--	--	--	--
THM-1	--	--	--	--	--	0.018	0.012	--	--	--	--	--	--	--	--	0.14	<0.010	<0.010	--	--
THS-1E	--	--	--	--	--	--	--	--	--	--	--	--	--	--	--	--	--	--	--	--
THS-1W	--	--	--	--	--	--	--	--	--	--	--	--	--	--	--	--	--	--	--	<0.010
THW-1	1.1	<0.010	--	--	--	--	--	--	--	--	--	--	--	--	--	--	--	--	--	--
TW-1E	--	--	--	--	0.29	--	0.015	--	0.16	<0.010	<0.010	--	<0.010	--	<0.010	--	--	--	--	--
TW-1W	--	--	--	--	--	--	<0.010	--	--	--	--	--	--	--	--	--	--	--	--	--
TW-2E	--	--	--	--	0.14	0.061	0.055	0.041	0.32	0.057	<0.010	<0.010	--	--	--	--	<0.010	--	--	--
TW-3E	1.6	--	--	--	--	0.025	0.022	0.025	0.24	--	<0.010	--	--	--	--	--	--	--	--	--
TW-4E	--	--	--	--	--	0.015	<0.010	0.019	0.17	0.028	<0.010	--	--	--	--	--	--	--	--	<0.010

Table 8.2-2 (continued)

Reach	Arsenic	Chromium (1)	Aniline (1)	Aroclor-1242 ^a	Aroclor-1248 ^a	Aroclor-1254 ^a	Aroclor-1260 ^a	Benzo(a)anthracene	Benzo(a)pyrene	Benzo(b)fluoranthene	Benzo(g,h,i)perylene	Benzo(k)fluoranthene	BHC[alpha-]	BHC[beta-]	BHC[gamma-]	Bis(2-chloroethyl)ether	Bis(2-ethylhexyl)phthalate	Chlordane[alpha-] (2)	Chlordane[gamma-] (2)	Chloroform
TW-4W	--	--	--	--	--	0.026	0.018	0.022	0.17	0.027	--	--	--	--	--	--	--	--	--	--
TWN-1E	--	--	--	--	0.027	0.084	0.074	6.3	43	0.13	<0.010	--	--	--	--	--	--	--	--	<0.010
TWN-1W	1.1	<0.010	--	--	--	--	--	--	--	--	--	--	--	--	--	--	<0.010	--	--	<0.010
TWSE-1E	1.1	<0.010	--	--	--	<0.010	<0.010	<0.010	0.0340	--	--	--	--	--	--	--	<0.010	--	--	--
TWSE-1W	1.5	<0.010	--	--	--	--	0.015	--	--	--	--	--	--	--	--	--	--	--	--	--
TWSW-1E	1.2	<0.010	--	--	--	<0.010	--	--	--	--	--	--	--	--	--	--	--	--	--	--
TWSW-1W	1.4	<0.010	--	<0.010	--	<0.010	<0.010	--	--	--	--	--	--	--	--	--	--	--	--	--

Table 8.2-2 (continued)

Reach	Chrysene	DDD[4,4'-]	DDE[4,4'-]	DDT[4,4'-]	Dibenzofuran	Dichlorobenzene[1,4-]	Dichloroethane[1,2-]	Dieldrin	Heptachlor Epoxide (1)	Heptachlorodibenzodioxin[1,2,3,4,6,7,8] ^b	Heptachlorodibenzofuran[1,2,3,4,6,7,8] ^b	Hexachlorodibenzodioxin[1,2,3,4,7,8] ^b	Hexachlorodibenzodioxin[1,2,3,6,7,8] ^b	Hexachlorodibenzodioxin[1,2,3,7,8,9] ^b	Hexachlorodibenzofuran[1,2,3,4,7,8] ^b	Hexachlorodibenzofuran[1,2,3,6,7,8] ^b	Hexachlorodibenzofuran[1,2,3,7,8,9] ^b	Hexachlorodibenzofuran[2,3,4,6,7,8] ^b	Indeno(1,2,3-cd)pyrene	Methylene Chloride
SSL (mg/kg)	615	24.4	17.2	17.2	142	39.5	6.04	0.304	0.53	3.90E-03	3.90E-03	3.90E-04	3.90E-04	3.90E-04	3.90E-04	3.90E-04	3.90E-04	3.90E-04	6.21	182
Endpoint	ca	ca	ca	ca	ca	ca	ca	ca	ca	ca	ca	ca	ca	ca	ca	ca	ca	ca	ca	ca
AEN-1	<0.010	--	--	--	--	--	--	--	--	--	--	--	--	--	--	--	--	--	--	--
AES-1	<0.010	--	--	<0.010	--	--	--	--	--	--	--	--	--	--	--	--	--	--	--	--
AW-1	<0.010	--	<0.010	<0.010	--	--	--	--	--	--	--	--	--	--	--	--	--	--	--	--
PA-0	--	--	<0.010	<0.010	--	--	--	--	--	--	--	--	--	--	--	--	--	--	--	--
PA-1E	<0.010	--	<0.010	<0.010	--	--	--	--	--	--	--	--	--	--	--	--	--	--	--	<0.010
PA-1W	<0.010	--	--	--	--	--	--	--	--	--	--	--	--	--	--	--	--	--	--	--
PA-2W	<0.010	--	<0.010	--	--	--	--	--	--	--	--	--	--	--	--	--	--	--	--	--
PA-3E	<0.010	--	<0.010	--	--	<0.010	--	--	--	0.013	<0.010	<0.010	<0.010	<0.010	<0.010	<0.010	--	<0.010	--	--
PA-4	<0.010	<0.010	<0.010	--	--	--	--	<0.010	--	--	--	--	--	--	--	--	--	--	0.013	--
PA-4E	--	--	<0.010	<0.010	--	--	--	--	--	--	--	--	--	--	--	--	--	--	--	--
PA-5W	<0.010	--	<0.010	<0.010	--	--	--	--	--	--	--	--	--	--	--	--	--	--	--	--
PAS-1E	<0.010	--	<0.010	<0.010	<0.010	--	<0.010	--	--	--	--	--	--	--	--	--	--	--	--	<0.010
PAS-2W	<0.010	--	--	<0.010	<0.010	<0.010	--	--	--	--	--	--	--	--	--	--	--	--	0.011	<0.010
TH-1C	--	--	--	--	--	<0.010	--	--	--	--	--	--	--	--	--	--	--	--	--	<0.010
TH-1E	<0.010	--	--	--	--	--	--	--	--	--	--	--	--	--	--	--	--	--	--	--
TH-3	--	--	--	--	--	--	--	--	--	--	--	--	--	--	--	--	--	--	--	--
THM-1	--	--	--	--	--	--	--	--	<0.010	--	--	--	--	--	--	--	--	--	--	<0.010
THS-1E	--	--	--	--	--	<0.010	--	--	--	--	--	--	--	--	--	--	--	--	--	--
THS-1W	--	--	--	--	--	--	--	--	--	--	--	--	--	--	--	--	--	--	--	--
THW-1	--	--	--	--	--	--	--	--	--	--	--	--	--	--	--	--	--	--	--	--
TW-1E	<0.010	--	<0.010	<0.010	--	--	--	--	--	<0.010	<0.010	<0.010	<0.010	<0.010	<0.010	<0.010	<0.010	<0.010	0.011	--

Table 8.2-2 (continued)

Reach	Chrysene	DDD[4,4']	DDE[4,4']	DDT[4,4']	Dibenzofuran	Dichlorobenzene[1,4-]	Dichloroethane[1,2-]	Dieldrin	Heptachlor Epoxide (1)	Heptachlorodibenzodioxin[1,2,3,4,6,7,8] ^b	Heptachlorodibenzofuran[1,2,3,4,6,7,8] ^b	Hexachlorodibenzodioxin[1,2,3,4,7,8] ^b	Hexachlorodibenzodioxin[1,2,3,6,7,8] ^b	Hexachlorodibenzodioxin[1,2,3,7,8,9] ^b	Hexachlorodibenzofuran[1,2,3,4,7,8] ^b	Hexachlorodibenzofuran[1,2,3,6,7,8] ^b	Hexachlorodibenzofuran[1,2,3,7,8,9] ^b	Hexachlorodibenzofuran[2,3,4,6,7,8] ^b	Indeno(1,2,3-cd)pyrene	Methylene Chloride
TW-1W	--	--	<0.010	<0.010	--	--	--	--	--	<0.010	<0.010	--	<0.010	<0.010	--	--	--	<0.010	--	<0.010
TW-2E	<0.010	--	<0.010	--	--	--	--	--	--	<0.010	<0.010	<0.010	<0.010	<0.010	<0.010	<0.010	<0.010	<0.010	--	--
TW-3E	<0.010	--	--	--	--	--	--	--	--	--	--	--	--	--	--	--	--	--	--	<0.010
TW-4E	<0.010	--	--	--	--	--	--	--	--	0.016	<0.010	<0.010	<0.010	<0.010	<0.010	<0.010	--	<0.010	--	<0.010
TW-4W	<0.010	--	--	--	--	--	--	--	--	--	--	--	--	--	--	--	--	--	<0.010	--
TWN-1E	0.044	--	--	--	<0.010	--	--	--	--	--	--	--	--	--	--	--	--	--	0.069	--
TWN-1W	--	--	--	--	--	--	--	--	--	--	--	--	--	--	--	--	--	--	--	--
TWSE-1E	<0.010	--	--	--	--	<0.010	--	--	--	--	--	--	--	--	--	--	--	--	--	--
TWSE-1W	--	--	<0.010	--	--	--	--	--	--	--	--	--	--	--	--	--	--	--	--	<0.010
TWSW-1E	--	--	--	--	--	--	--	--	--	--	--	--	--	--	--	--	--	--	--	--
TWSW-1W	<0.010	--	--	--	--	--	--	--	--	--	--	--	--	--	--	--	--	--	--	--

Table 8.2-2 (continued)

Reach	Nitrotoluene[2-]	Octachlorodibenzodioxin[1,2,3,4,6,7,8,9] ^b	Octachlorodibenzofuran[1,2,3,4,6,7,8,9] ^b	Pentachlorodibenzodioxin[1,2,3,7,8] ^b	Pentachlorodibenzofuran[1,2,3,7,8] ^b	Pentachlorodibenzofuran[2,3,4,7,8] ^b	RDX	Tetrachlorodibenzodioxin[2,3,7,8] ^b	Tetrachlorodibenzofuran[2,3,7,8] ^b	Tetrachloroethene	Toxaphene (Technical Grade)	Trichloroethene	SOF
SSL (mg/kg)	10.8	1.30E-01	1.30E-01	3.90E-05	1.30E-03	1.30E-04	44.2	3.90E-05	3.90E-04	12.5	4.42	0.638	
Endpoint	ca	ca	ca	ca	ca	ca	ca	ca	ca	ca	ca	ca	
AEN-1	--	--	--	--	--	--	--	--	--	--	--	--	2.6
AES-1	--	--	--	--	--	--	--	--	--	--	--	--	1.5
AW-1	--	--	--	--	--	--	--	--	--	--	--	--	8.1
PA-0	0.041	--	--	--	--	--	--	--	--	--	--	--	<0.1
PA-1E	0.023	--	--	--	--	--	--	--	--	--	--	--	1.1
PA-1W	--	--	--	--	--	--	--	--	--	--	--	--	<0.1
PA-2W	--	--	--	--	--	--	--	--	--	--	--	--	<0.1
PA-3E	--	<0.010	<0.010	<0.010	--	<0.010	--	--	<0.010	--	--	--	0.4
PA-4	--	--	--	--	--	--	--	--	--	--	--	--	2.3
PA-4E	<0.010	--	--	--	--	--	--	--	--	--	--	--	<0.10
PA-5W	--	--	--	--	--	--	--	--	--	--	--	--	1.7
PAS-1E	--	--	--	--	--	--	--	--	--	--	--	--	2.1
PAS-2W	--	--	--	--	--	--	--	--	--	<0.010	--	--	1.5
TH-1C	--	--	--	--	--	--	--	--	--	--	--	<0.010	1.1
TH-1E	--	--	--	--	--	--	--	--	--	--	--	--	1.9
TH-3	--	--	--	--	--	--	--	--	--	--	--	--	-
THM-1	--	--	--	--	--	--	--	--	--	--	--	--	0.17
THS-1E	--	--	--	--	--	--	--	--	--	<0.010	--	<0.010	0.0015
THS-1W	--	--	--	--	--	--	--	--	--	--	--	--	<0.10
THW-1	--	--	--	--	--	--	--	--	--	--	--	--	1.1
TW-1E	--	<0.010	<0.010	0.046	<0.010	0.023	--	<0.010	0.021	--	0.039	<0.010	0.67
TW-1W	--	<0.010	<0.010	--	--	--	--	--	--	--	--	--	0.0094
TW-2E	--	<0.010	<0.010	0.011	<0.010	0.014	--	<0.010	0.011	--	--	--	0.74
TW-3E	--	--	--	--	--	--	--	--	--	--	--	--	1.9
TW-4E	--	<0.010	<0.010	0.012	<0.010	<0.010	--	--	<0.010	--	--	--	0.30
TW-4W	--	--	--	--	--	--	--	--	--	<0.010	--	--	0.27

Table 8.2-2 (continued)

Reach	Nitrotoluene[2-]	Octachlorodibenzodioxin[1,2,3,4,6,7,8,9] ^b	Octachlorodibenzofuran[1,2,3,4,6,7,8,9] ^b	Pentachlorodibenzodioxin[1,2,3,7,8] ^b	Pentachlorodibenzofuran[1,2,3,7,8] ^b	Pentachlorodibenzofuran[2,3,4,7,8] ^b	RDX	Tetrachlorodibenzodioxin[2,3,7,8] ^b	Tetrachlorodibenzofuran[2,3,7,8] ^b	Tetrachloroethene	Toxaphene (Technical Grade)	Trichloroethene	SOF
TWN-1E	--	--	--	--	--	--	--	--	--	--	--	<0.010	49
TWN-1W	--	--	--	--	--	--	--	--	--	--	--	--	1.1
TWSE-1E	--	--	--	--	--	--	--	--	--	<0.010	--	--	1.1
TWSE-1W	--	--	--	--	--	--	<0.010	--	--	--	--	--	1.6
TWSW-1E	--	--	--	--	--	--	--	--	--	--	--	--	1.2
TWSW-1W	--	--	--	--	--	--	--	--	--	--	--	--	1.4

Notes: Residential SSL are from NMED 2006, unless otherwise noted. COPCs and reaches shaded grey are those retained for the risk assessment. Ratios in bold and grey shading show where the SOF ≥ 1 and/or the individual COPC ratio is >0.1 . All values are mg/kg. All values from EPA Region 6 HHMSLs adjusted to TR 10^{-5} . EPA Region 6 HHMSLs (2005, 91002), NMED SSLs (2006, 92513). WHO 2005 TEF. The following numbers are used in this table: 1 = EPA Region 6 SSLs; 2 = chlordane surrogate, NMED SSLs.

^a ca endpoint EPA Region 6 SSLs.

^b 2,3,7,8-hexachlorodibenzodioxin EPA Region 6 SSL modified by WHO 2005 TEF (= SSL × TEF).

^c -- = All results were nondetect or no data was available.

**Table 8.2-3
Residential Risk Ratios Used to Identify Sediment COPCs, Radionuclide**

SOF	Americium-241	Cesium-134	Cesium-137	Plutonium-238	Plutonium-239/240	Thorium-228	Thorium-232	Tritium	Uranium-234	Uranium-235	Uranium-238	SOF
Residential SAL (pCi/g)	30	2.4	5.6	37	33	2.3	5	750	170	17	86	SOF
AEN-1	--*	--	0.17	--	--	--	--	<0.010	0.018	0.014	0.034	0.23
AES-1	--	--	--	--	--	--	--	--	--	--	--	-
AW-1	--	--	0.17	--	--	--	--	--	0.031	0.025	0.040	0.27
PA-0	<0.010	--	0.88	0.013	0.11	--	--	--	--	--	--	1.0
PA-1E	<0.010	--	--	--	--	--	--	--	--	--	--	<0.10
PA-1W	--	--	--	--	--	--	--	--	--	--	--	-
PA-2W	--	0.045	0.31	--	<0.010	--	--	<0.010	--	--	0.036	0.40
PA-3E	<0.010	--	0.79	<0.010	<0.010	--	--	<0.010	--	--	0.027	0.82
PA-4	<0.010	--	0.75	<0.010	<0.010	1.0	--	--	--	--	--	1.8
PA-4E	--	--	0.32	--	--	--	--	--	--	--	--	0.32
PA-5W	--	--	0.29	--	<0.010	--	--	--	--	--	--	0.29
PAS-1E	--	--	0.41	--	--	--	--	--	--	--	--	0.41
PAS-2W	--	0.050	--	--	--	--	--	--	--	--	--	0.050
TH-1C	--	--	0.18	--	--	--	--	--	0.020	0.015	0.056	0.27
TH-1E	--	--	0.23	--	--	--	--	<0.010	0.029	0.023	0.077	0.36
TH-3	--	--	0.17	--	--	--	--	--	0.028	0.020	0.11	0.33

Table 8.2-3 (continued)

SOF	Americium-241	Cesium-134	Cesium-137	Plutonium-238	Plutonium-239/240	Thorium-228	Thorium-232	Tritium	Uranium-234	Uranium-235	Uranium-238	SOF
THM-1	--	--	0.19	--	--	--	--	<0.010	0.052	0.078	0.60	0.93
THS-1E	--	--	--	--	--	1.3	0.51	<0.010	0.049	0.048	0.24	2.2
THS-1W	--	--	--	--	--	--	--	--	0.13	0.074	0.54	0.74
THW-1	--	--	0.24	--	--	--	--	--	0.035	0.022	0.093	0.39
TW-1E	--	--	--	--	--	--	--	<0.010	--	--	--	<0.10
TW-1W	--	--	--	--	--	--	--	--	--	--	--	-
TW-2E	--	--	0.17	--	--	--	--	--	--	0.012	--	0.18
TW-3E	<0.010	--	0.18	--	--	--	--	--	--	--	--	0.18
TW-4E	--	--	0.16	--	<0.010	--	--	--	--	--	0.032	0.20
TW-4W	--	--	--	--	<0.010	--	--	--	--	--	--	-
TWN-1E	--	--	0.42	--	<0.010	--	--	--	--	--	--	0.43
TWN-1W	--	--	0.24	--	--	--	--	--	--	--	--	0.24
TWSE-1E	--	--	0.19	--	<0.010	--	--	--	--	--	--	0.19
TWSE-1W	--	--	--	--	--	--	--	--	--	--	--	-
TWSW-1E	<0.010	--	0.53	--	0.032	--	--	<0.010	0.016	--	0.044	0.63
TWSW-1W	--	--	--	--	--	--	--	--	--	--	--	-

Notes: All values are from LANL (2005, 088493) unless otherwise noted. Ratios in grey shading show where the $SOF_r > 1$ and/or the individual COPC ratio is > 0.1 . COPCs and reaches shaded in grey are those retained for the risk assessment.

*-- Maximum concentration is less than background, all results were nondetect, or no data were available.

**Table 8.2-4
Residential Risk Ratios Used to Identify Surface Water COPCs, Noncarcinogens**

Location	Aluminum	Ammonia as Nitrogen	Antimony	Barium	Beryllium	Boron	Cadmium	Chloride(1)	Cobalt	Copper	Cyanide (Total)	Cyanide, Amenable to Chlorination	Fluoride	Iron	Lead
Human Health Standard	36500	208.6	14.6	7300	73	7300	18.25	250000	730	1356	730	730	2190	25550	15
Endpoint	nc ^a	nc	nc	nc	nc	nc	nc	nc	nc	nc	nc	nc	nc	nc	nc
Anderson Spring	0.25	0.55	-- ^b	<0.01	--	<0.01	<0.01	0.034	--	<0.01	--	--	0.16	0.20	0.23
Bulldog Spring	0.27	0.40	--	0.014	--	<0.01	<0.01	0.11	<0.01	<0.01	--	--	0.15	0.20	0.22
Charlie's Spring	0.35	--	--	0.014	--	<0.01	<0.01	0.10	<0.01	<0.01	--	--	0.077	0.24	0.30
Homestead Spring	0.31	0.83	--	0.011	--	<0.01	<0.01	0.067	<0.01	<0.01	--	--	0.066	0.24	0.30
Kieling Spring	0.38	0.25	--	0.016	--	<0.01	0.011	0.11	<0.01	<0.01	--	--	0.084	0.27	0.40
PC Spring	0.10	0.91	--	<0.01	--	--	--	<0.01	--	--	--	--	0.060	0.045	0.056
Spring 4	<0.01	--	--	<0.01	--	<0.01	--	0.027	--	--	<0.01	--	0.22	<0.01	--
Spring 4A	--	--	--	<0.01	--	<0.01	--	0.021	--	--	--	--	0.24	--	0.061
Spring 4AA	<0.01	--	--	<0.01	--	<0.01	--	0.023	--	--	--	--	0.24	<0.01	--
Spring 4B	0.035	--	--	<0.01	--	<0.01	--	0.032	<0.01	0.04	<0.01	--	0.23	0.045	0.039
Spring 4C	--	--	--	<0.01	--	<0.01	--	0.026	--	--	<0.01	--	0.22	<0.01	--
Starmer Spring	0.30	0.41	--	0.012	--	<0.01	<0.01	0.092	<0.01	<0.01	--	--	0.068	0.22	0.25
TA-18 Spring	0.12	--	--	0.014	--	<0.01	<0.01	0.087	<0.01	<0.01	--	--	0.084	0.15	0.062
TW-1.72 Spring	0.25	--	0.34	<0.01	--	<0.01	--	0.374	<0.01	<0.01	--	--	0.11	0.18	0.18
Threemile Spring	0.08	--	--	0.011	--	<0.01	--	0.086	--	<0.01	--	--	0.073	0.05	0.060
La Delfe above Pajarito	0.18	--	--	0.011	<0.01	<0.01	<0.01	0.052	--	<0.01	--	--	0.073	0.13	0.14

Table 8.2-4 (continued)

Location	Aluminum	Ammonia as Nitrogen	Antimony	Barium	Beryllium	Boron	Cadmium	Chloride(1)	Cobalt	Copper	Cyanide (Total)	Cyanide, Amenable to Chlorination	Fluoride	Iron	Lead
Pajarito 0.5 mi above SR-501	0.16	0.68	--	0.010	--	<0.01	<0.01	0.053	<0.01	<0.01	--	--	0.066	0.12	0.14
Pajarito above SR-4	0.026	--	--	0.019	--	--	--	--	--	--	--	--	--	0.02	0.035
Pajarito above Starmers	0.080	--	--	<0.01	<0.01	<0.01	--	0.018	<0.01	<0.01	--	--	0.027	0.06	0.055
Pajarito above TA-18	0.18	--	--	0.011	--	<0.01	<0.01	--	--	<0.01	--	--	--	0.14	0.17
Pajarito above Threemile	0.19	--	--	0.012	--	<0.01	--	--	--	<0.01	--	--	--	0.14	0.19
Pajarito above Twomile	0.20	0.35	--	0.012	<0.01	<0.01	<0.01	0.11	<0.01	<0.01	--	--	0.10	0.14	0.15
Pajarito at Rio Grande	<0.01	--	--	<0.01	--	<0.01	--	0.021	--	--	--	--	0.22	<0.01	--
Pajarito below SR-501	0.044	--	--	<0.01	<0.01	--	--	--	--	--	--	--	--	0.027	0.037
Pajarito below TA-18	0.081	--	--	<0.01	--	<0.01	--	0.023	--	--	--	--	--	0.054	0.040
Pajarito below confluences of South and North Anchor East Basin	0.30	0.49	--	0.013	--	<0.01	<0.01	0.074	<0.01	<0.01	--	--	0.070	0.23	0.27
Starmers above Pajarito	0.15	--	--	<0.01	<0.01	<0.01	--	0.026	--	<0.01	--	<0.01	--	0.10	0.11
Threemile above Pajarito	0.11	--	--	<0.01	--	--	--	--	--	<0.01	--	--	--	0.085	0.11
Two Mile below TA-59	0.29	9.40	0.082	0.014	--	<0.01	<0.01	0.66	<0.01	<0.01	--	--	0.13	0.24	0.29
Twomile above Pajarito	--	--	--	--	--	--	--	--	--	--	--	--	--	--	--

Table 8.2-4 (continued)

Location	Manganese	Mercury	Molybdenum	Nickel	Perchlorate	Selenium	Silver	Sodium (1)	Strontium	Sulfate	Thallium	Tin	Uranium (2)	Vanadium	Zinc
Human Health Standard	1703	0.6257	182.5	730	24.5	182.5	182.5	20000	21900	250000	2.555	21900	30	182.5	10950
Endpoint	nc	nc	nc	nc	nc	nc	nc	nc	nc	nc	nc	nc	nc	nc	nc
Anderson Spring	0.03	--	0.012	<0.01	0.026	--	<0.01	0.88	<0.01	0.037	0.22	<0.01	0.03	0.057	<0.01
Bulldog Spring	0.02	--	<0.01	<0.01	0.044	0.029	<0.01	1.1	<0.01	0.048	0.24	--	0.02	0.053	<0.01
Charlie's Spring	0.02	0.19	<0.01	<0.01	0.018	--	0.033	0.77	<0.01	0.060	0.23	--	0.02	0.061	<0.01
Homestead Spring	0.02	0.59	<0.01	<0.01	0.017	0.016	--	0.57	<0.01	0.052	0.27	<0.01	0.01	0.054	<0.01
Kieling Spring	0.05	0.89	<0.01	<0.01	0.035	0.024	0.030	1.0	<0.01	0.050	0.22	--	0.05	0.076	<0.01
PC Spring	<0.01	--	--	<0.01	0.019	--	--	0.21	<0.01	0.042	0.22	--	0.05	0.018	<0.01
Spring 4	--	--	0.014	<0.01	0.027	<0.01	--	0.73	<0.01	0.040	--	--	0.04	0.061	<0.01
Spring 4A	--	--	<0.01	<0.01	0.022	--	--	0.63	<0.01	0.026	0.17	--	0.04	0.046	<0.01
Spring 4AA	<0.01	--	--	<0.01	0.024	--	--	0.65	<0.01	0.028	0.13	--	0.03	0.045	<0.01
Spring 4B	0.01	1.4	--	<0.01	0.021	<0.01	--	0.71	<0.01	0.039	0.18	--	0.06	0.067	<0.01
Spring 4C	--	--	0.016	<0.01	0.029	<0.01	--	0.71	<0.01	0.038	--	--	0.07	0.058	<0.01
Starmer Spring	0.04	0.074	<0.01	<0.01	0.019	--	<0.01	0.78	<0.01	0.057	0.23	<0.01	0.01	0.050	<0.01
TA-18 Spring	0.18	0.080	0.013	<0.01	<0.01	--	--	0.92	<0.01	0.15	0.19	--	<0.01	0.021	<0.01
TW-1.72 Spring	0.09	--	0.021	<0.01	<0.01	--	--	4.09	<0.01	0.046	--	--	<0.01	0.039	<0.01
Threemile Spring	0.01	--	--	<0.01	0.014	--	--	0.88	<0.01	0.066	0.17	--	0.01	0.014	--
La Delfe above Pajarito	0.01	0.089	<0.01	<0.01	0.025	0.01	<0.01	0.83	<0.01	0.043	0.18	--	<0.01	0.035	<0.01
Pajarito 0.5 mi above SR-501	0.02	--	<0.01	<0.01	0.021	--	<0.01	0.61	<0.01	0.051	0.24	<0.01	<0.01	0.034	<0.01
Pajarito above SR-4	<0.01	--	0.012	<0.01	0.012	0.01	--	2.6	--	--	0.20	--	--	--	<0.01
Pajarito above Starmers	0.16	0.088	--	<0.01	0.015	0.02	--	0.47	<0.01	0.032	--	--	--	0.013	<0.01
Pajarito above TA-18	0.03	--	<0.01	<0.01	0.016	--	<0.01	1.1	<0.01	--	--	--	<0.01	0.033	<0.01
Pajarito above Threemile	0.03	--	--	<0.01	0.017	--	<0.01	1.1	<0.01	--	--	--	<0.01	0.033	<0.01
Pajarito above Twomile	0.02	--	<0.01	<0.01	0.020	--	<0.01	1.1	<0.01	0.059	0.33	--	<0.01	0.035	<0.01

Table 8.2-4 (continued)

Location	Manganese	Mercury	Molybdenum	Nickel	Perchlorate	Selenium	Silver	Sodium (1)	Strontium	Sulfate	Thallium	Tin	Uranium (2)	Vanadium	Zinc
Pajarito at Rio Grande	<0.01	--	<0.01	<0.01	0.020	--	--	0.69	<0.01	0.022	0.18	--	0.04	0.054	--
Pajarito below SR-501	<0.01	--	--	<0.01	0.020	--	--	0.31	--	--	--	--	--	<0.01	<0.01
Pajarito below TA-18	<0.01	--	--	<0.01	<0.01	--	<0.01	0.48	<0.01	0.037	--	--	<0.01	0.020	--
Pajarito below confluences of South and North Anchor East Basin	0.03	--	0.012	<0.01	0.018	--	<0.01	0.70	<0.01	0.056	0.21	--	0.01	0.055	<0.01
Starmers above Pajarito	0.01	0.12	--	<0.01	0.018	--	<0.01	0.65	<0.01	0.032	--	--	<0.01	0.022	<0.01
Threemile above Pajarito	0.02	--	--	<0.01	<0.01	--	--	0.50	--	--	--	--	--	0.016	<0.01
Two Mile below TA-59	0.03	--	0.021	<0.01	<0.01	--	<0.01	5.2	<0.01	0.047	0.20	<0.01	0.01	0.055	<0.01
Twomile above Pajarito	--	--	--	--	--	--	--	--	--	--	--	--	--	--	--

Table 8.2-4 (continued)

Location	Acetone	Benzoic Acid	Butanone[2-]	Chlorophenol[2-]	Dichlorobenzene[1,2-]	Dichlorobenzene[1,3-]	Endosulfan II (3)	Endrin (3)	Endrin Aldehyde	HMX	Naphthalene	Toluene	SOF
Human Health Standard	5475	146000	7065	30.42	49.31	14.48	89	0.81	0.3	1825	6.203	2281	
Endpoint	nc	nc	nc	nc	nc	nc	nc	nc	nc	nc	nc	nc	
Anderson Spring	<0.010	--	<0.010	--	--	0.037	--	--	--	--	--	<0.010	2.8
Bulldog Spring	<0.010	--	<0.010	--	--	0.023	<0.010	<0.010	--	<0.010	--	--	3.0
Charlie's Spring	--	--	<0.010	--	<0.010	--	--	--	--	--	--	--	2.5
Homestead Spring	<0.010	--	<0.010	--	--	--	--	--	--	--	--	--	3.5
Kieling Spring	<0.010	--	<0.010	--	--	0.025	--	--	--	<0.010	--	<0.010	4.0
PC Spring	<0.010	<0.010	<0.010	--	--	--	--	--	--	--	--	--	1.8
Spring 4	--	--	--	0.014	--	--	--	--	--	--	--	--	1.2
Spring 4A	<0.010	--	<0.010	--	--	--	--	--	--	--	--	--	1.3
Spring 4AA	<0.010	--	<0.010	--	--	--	--	--	--	--	--	<0.010	1.2
Spring 4B	<0.010	--	<0.010	--	--	--	--	--	--	--	--	<0.010	2.9
Spring 4C	--	--	<0.010	--	--	--	--	--	--	--	--	--	1.2
Starmer Spring	--	--	<0.010	--	--	--	--	--	--	--	--	--	2.6
TA-18 Spring	<0.010	--	--	--	--	--	--	--	--	--	--	--	2.1
TW-1.72 Spring	<0.010	--	--	--	--	--	--	--	--	--	--	--	5.7
Threemile Spring	<0.010	--	--	--	--	--	--	--	--	<0.010	--	--	1.5
La Delfe above Pajarito	--	--	--	--	--	--	--	--	--	<0.010	--	--	1.9
Pajarito 0.5 mi above SR-501	<0.010	--	--	--	--	--	--	--	--	--	--	--	2.2
Pajarito above SR-4	--	--	--	--	--	--	--	--	--	--	--	--	3.0
Pajarito above Starmer's	--	--	--	--	--	--	--	--	--	--	--	--	1.1
Pajarito above TA-18	--	--	--	--	--	--	--	--	--	--	--	--	1.7

Table 8.2-4 (continued)

Location	Acetone	Benzoic Acid	Butanone[2-]	Chlorophenol[2-]	Dichlorobenzene[1,2-]	Dichlorobenzene[1,3-]	Endosulfan II (3)	Endrin (3)	Endrin Aldehyde	HMX	Naphthalene	Toluene	SOF
Pajarito above Threemile	--	--	--	--	--	--	--	--	--	--	--	--	1.8
Pajarito above Twomile	<0.010	--	--	--	--	--	--	--	--	<0.010	--	--	2.6
Pajarito at Rio Grande	--	--	--	--	--	--	--	--	--	--	0.045	--	1.3
Pajarito below SR-501	--	--	--	--	--	--	--	--	--	--	--	--	0.45
Pajarito below TA-18	--	--	--	--	--	--	--	--	--	<0.010	--	--	0.78
Pajarito below confluences of South and North Anchor East Basin	<0.010	--	--	--	--	--	--	--	--	<0.010	--	--	2.6
Starmers above Pajarito	--	--	--	--	--	--	--	--	--	--	--	--	1.3
Threemile above Pajarito	--	--	--	--	--	--	--	--	--	--	--	--	0.86
Two Mile below TA-59	<0.010	--	--	--	--	--	--	--	0.031	--	--	--	17
Twomile above Pajarito	--	--	--	--	--	--	--	--	--	--	--	--	-

Notes: COPs and water locations shaded in grey are those retained for the further assessment. Unless otherwise noted, all screening levels are EPA Region 6 Tap Water (TR 10⁻⁵), 1 = SMCL EPA Secondary Drinking Water Std, Maximum Contaminant Level (SMCL), 2 = MCL EPA Primary Drinking Water Std, MCL, 3 = NMHH NMED HH Standards (NMAC 20.6.4).

^a nc = Noncarcinogen.

^b -- = All results were nondetect, or no data were available.

**Table 8.2-5
Residential Risk Ratios Used to Identify Surface Water COPCs, Carcinogens**

Location	Arsenic	Benzo(b)fluoranthene (1)	Benzo(k)fluoranthene (1)	Chloroform	DDD[4,4'] (1)	DDE[4,4'] (1)	DDT[4,4'] (1)	Dieldrin (1)	RDX	Trichloroethene	SOF
Human Health Standard	0.4482	0.18	0.18	1.67	0.0022	0.0022	0.002	0.001	6.112	1.657	
Endpoint	ca ^a	ca	ca	ca	ca	ca	ca	ca	ca	ca	
Anderson Spring	5.8	-- ^b	--	0.24	--	--	--	--	--	--	6.0
Bulldog Spring	3.6	--	--	--	11	10	7.9	14	1.1	0.21	47
Charlie's Spring	5.1	--	--	--	--	--	--	--	--	--	5.1
Homestead Spring	11	--	--	--	--	--	--	--	--	--	11
Kieling Spring	17	--	--	--	--	--	--	--	0.10	--	17
PC Spring	5.4	--	--	--	--	--	--	--	--	--	5.4
Spring 4	12	40	2.8	--	--	--	--	--	--	--	55
Spring 4A	9.6	--	--	--	--	--	--	--	--	--	9.6
Spring 4AA	10	--	--	--	--	--	--	--	--	--	10
Spring 4B	10	--	--	--	--	--	--	--	--	--	10
Spring 4C	14	--	--	--	--	--	--	--	--	--	14
Starmer Spring	4.5	--	--	--	--	--	--	--	--	--	4.5
TA-18 Spring	--	--	--	--	--	--	--	--	--	--	--
TW-1.72 Spring	3.3	--	--	--	--	--	--	--	--	--	3.3

Table 8.2-5 (continued)

Location	Arsenic	Benzo(b)fluoranthene (1)	Benzo(k)fluoranthene (1)	Chloroform	DDD[4,4'] (1)	DDE[4,4'] (1)	DDT[4,4'] (1)	Dieldrin (1)	RDX	Trichloroethene	SOF
Threemile Spring	--	--	--	--	--	--	--	--	--	--	--
La Delfe above Pajarito	6.9	--	--	--	--	--	--	--	0.25	--	7.2
Pajarito 0.5 mi above SR-501	4.5	--	--	--	--	--	--	--	--	--	4.5
Pajarito above SR-4	8.7	--	--	--	--	--	--	--	--	--	8.7
Pajarito above Starmers	5.1	--	--	--	--	--	--	--	--	--	5.1
Pajarito above TA-18	--	--	--	--	--	--	--	--	--	--	--
Pajarito above Threemile	--	--	--	--	--	--	--	--	--	--	--
Pajarito above Twomile	3.6	--	--	--	--	--	--	--	0.033	--	3.6
Pajarito at Rio Grande	--	--	--	--	--	--	--	--	--	--	--
Pajarito below SR-501	--	--	--	--	--	--	--	--	--	--	--
Pajarito below TA-18	--	--	--	--	--	--	--	--	--	--	--
Pajarito below confluences of South and North Anchor East Basin	5.1	--	--	--	--	--	--	--	0.14	--	5.3
Starmers above Pajarito	6.7	--	--	--	--	--	--	--	--	--	6.7

Table 8.2-5 (continued)

Location	Arsenic	Benzo(b)fluoranthene (1)	Benzo(k)fluoranthene (1)	Chloroform	DDD[4,4'] (1)	DDE[4,4'] (1)	DDT[4,4'] (1)	Dieldrin (1)	RDX	Trichloroethene	SOF
Threemile above Pajarito	--	--	--	--	--	--	--	--	--	--	--
Two Mile below TA-59	5.8	--	--	--	--	--	--	--	--	--	5.8
Twomile above Pajarito	--	--	--	--	--	--	--	--	--	--	--

Notes: Residential screening levels values are in mg/L. Ratios in grey shading show where the $SOF_{nc} > 1$ and/or the individual COPC ratio is > 0.1 . All values are $\mu\text{g/L}$. Unless otherwise noted, all screening levels are EPA Region 6 tap water (TR 10^{-5}). The following numbers are used in this table: 1 = NMHH = NMED HH standards (NMAC 20.6.4).

^a ca = Carcinogen.

^b -- All results were nondetect, or no data were available.

**Table 8.2-6
Residential Risk Ratios Used to Identify Surface Water COPCs, Radionuclides**

Location	Americium-241	Cesium-137	Cobalt-60	Neptunium-237	Plutonium-238	Plutonium-239/240	Potassium-40	Radium-226 (1)	Radium-228 (1)	Sodium-22	Strontium-90 (1)	Tritium (1)	Uranium-234	Uranium-235/236	Uranium-238	SOF
Human Health Standard	1.2	120	200	1.2	1.6	1.2	280	5	5	400	8	20000	20	24	24	
Anderson Spring	--*	--	--	--	--	--	--	--	--	--	--	<0.010	0.025	--	0.015	0.045
Bulldog Spring	--	--	--	--	--	--	--	0.14	--	--	--	<0.010	0.015	--	<0.010	0.16
Charlie's Spring	--	--	--	--	--	0.71	--	--	--	--	--	<0.010	<0.010	--	<0.010	0.73
Homestead Spring	--	--	--	--	--	--	--	0.54	0.63	--	--	<0.010	<0.010	--	<0.010	1.2
Kieling Spring	--	--	--	--	--	--	--	0.11	0.12	--	0.076	<0.010	0.019	<0.010	0.014	0.34
PC Spring	--	--	--	--	--	--	--	0.11	--	--	--	<0.010	<0.010	--	<0.010	0.12
Spring 4	--	--	--	--	--	--	--	--	--	--	--	<0.010	0.034	<0.010	0.016	0.054
Spring 4A	--	--	--	--	--	--	--	--	--	--	--	0.023	0.038	<0.010	0.016	0.079
Spring 4AA	--	--	--	--	--	--	--	--	--	--	--	<0.010	0.034	<0.010	0.012	0.048
Spring 4B	--	--	--	--	--	--	--	--	--	--	--	<0.010	0.039	<0.010	0.018	0.061
Spring 4C	--	--	--	--	--	--	--	--	--	--	--	<0.010	0.057	<0.010	0.026	0.086
Starmer Spring	--	--	--	--	--	--	--	0.26	0.17	--	--	<0.010	<0.010	--	<0.010	0.440
TA-18 Spring	--	--	--	--	--	--	--	--	--	--	--	<0.010	<0.010	--	<0.010	0.013
TW-1.72 Spring	--	--	--	--	--	--	0.089	--	--	--	--	--	--	--	--	0.089
Threemile Spring	--	--	--	--	--	--	--	--	--	--	--	<0.010	0.029	<0.010	0.065	0.10
La Delfe above Pajarito	--	--	--	--	--	--	--	--	--	--	--	--	--	--	--	--

Table 8.2-6 (continued)

Location	Americium-241	Cesium-137	Cobalt-60	Neptunium-237	Plutonium-238	Plutonium-239/240	Potassium-40	Radium-226 (1)	Radium-228 (1)	Sodium-22	Strontium-90 (1)	Tritium (1)	Uranium-234	Uranium-235/236	Uranium-238	SOF
Pajarito 0.5 mi above SR-501	--	--	--	--	--	-	0.13	--	--	--	0.048	<0.010	<0.010	--	<0.010	0.19
Pajarito above SR-4	--	--	--	--	--	--	--	--	--	--	0.093	--	0.011	--	0.010	0.11
Pajarito above Starmers	--	--	--	--	--	--	--	--	--	--	--	--	--	--	--	--
Pajarito above TA-18	--	--	--	--	--	--	--	--	--	--	0.020	<0.010	--	--	<0.010	0.032
Pajarito above Threemile	--	--	--	--	--	--	--	0.11	--	--	--	0.011	<0.010	--	<0.010	0.13
Pajarito above Twomile	--	--	--	--	0.12	0.16	--	--	0.48	--	--	0.010	<0.010	--	<0.010	0.78
Pajarito at Rio Grande	--	--	--	--	--	--	--	--	--	--	--	--	0.037	--	0.019	0.056
Pajarito below SR-501	--	--	--	--	--	--	--	--	--	--	--	--	--	--	--	--
Pajarito below TA-18	--	--	--	--	--	--	--	--	--	--	--	--	--	--	--	--
Pajarito below confluences of South and North Anchor East Basin	--	--	--	--	--	--	--	--	--	--	--	<0.010	0.039	--	<0.010	0.050
Starmers above Pajarito	--	--	--	--	--	--	--	--	--	--	--	0.014	<0.010	--	--	0.019
Threemile above Pajarito	--	--	--	--	--	--	--	--	--	--	0.060	--	0.010	--	0.018	0.088
Two Mile below TA-59	--	--	--	--	--	--	--	--	--	--	0.064	<0.010	<0.010	--	<0.010	0.084
Twomile above Pajarito	--	--	--	--	--	--	--	--	--	--	--	--	--	--	--	--

Notes: Residential screening levels values are in pCi/L. Ratios in grey shading show where the $SOF_{nc} > 1$ and/or the individual COPC ratio is > 0.1 . All values are pCi/L. Unless otherwise, noted all screening levels are DOE 4-mrem drinking water DCG.1 = MCL EPA primary drinking water std (MCL).

*-- = All results were nondetect, or no data were available.

**Table 8.2-7
Reaches Evaluated for Water, Sediment, and Multimedia Exposure**

Reach	Sediment	Surface Water	Multimedia
AEN-1	M_{nc}, M_c, O_{nc}, O_c	M_{nc}, M_c, O_c	yes
AES-1	M _{nc} , M _c	-*	-
AW-1	M _{nc} , M _c , O _{nc} , O _c	-	-
PA-0	R	M _{nc} , M _c	-
PA-1E	M_c	M _{nc} , M_c , O _c	yes
PA-1W	-	R, M _{nc} , M _c	-
PA-2W	M_{nc}	M_{nc} , M _c	yes
PA-3E	M_{nc}	M_{nc} , M _c	yes
PA-4	R, M_{nc} , M_c , O _c	M_{nc} , M_c	yes
PA-4E	-	-	-
PA-5W	M _{nc} , M _c , O _c	-	-
PAS-1E	M _{nc} , M _c	-	-
PAS-2W	-	-	-
TH-1C	M _{nc} , M _c	-	-
TH-1E	M _{nc} , M _c	-	-
TH-3	M _{nc}	-	-
THM-1	M _{nc}	-	-
THS-1E	R, M _{nc}	-	-
THS-1W	M _{nc}	-	-
THW-1	M _{nc} , M _c	-	-
TW-1E	-	-	-
TW-1W	-	-	-
TW-2E	M_{nc} , O _{nc}	M_{nc} , M _c	yes
TW-3E	M_c , O _c	M _{nc} , M_c	yes
TW-4E	-	-	-
TW-4W	-	-	-
TWN-1E	M _{nc} , O _{nc} , O _c	-	-
TWN-1W	M _c	-	-
TWSE-1E	M _{nc} , M _c	-	-
TWSE-1W	M _{nc} , M _c	-	-
TWSW-1E	M _{nc} , M _c	-	-
TWSW-1W	M _{nc} , M _c	-	-

Notes: Analyte class evaluated as: R = radionuclide; M_c = metal, carcinogen; M_{nc} = metal, noncarcinogen; O_c = organic, carcinogen; O_{nc} = organic, noncarcinogen. Bold: Analyte class evaluated for multimedia across sediment and surface water.

* - = Not evaluated.

Table 8.2-8
Site-Specific Exposure Scenarios and Complete Exposure Pathways

Exposure Pathways	Exposure Scenarios	
	Recreational	Residential
Incidental ingestion of soil	X	X
Inhalation of dust	X	X
Dermal contact with soil	X	X
Ingestion of surface water	X	—*
Dermal contact with surface water	X	—
External irradiation	X	X

* — = Incomplete pathway.

**Table 8.2-9
Risk-Based Screening Levels for the Recreational Scenario**

Medium	COPC	CAS ID	End Point	Target Adverse- Effect Level	Recreational SSL	Units	Reference
Sediment	Aluminum	7429-90-5	nc ^a	HQ=1	100000	mg/kg	LANL (2007, 094496)
Sediment	Aroclor-1248	12672-29-6	nc	HQ=1	6.65	mg/kg	LANL (2007, 094496)
Sediment	Aroclor-1254	11097-69-1	nc	HQ=1	6.65	mg/kg	LANL (2007, 094496)
Sediment	Aroclor-1254	11097-69-1	ca ^b	risk=10 ⁻⁵	10.5	mg/kg	EPA (2007, 101002)
Sediment	Aroclor-1260	11096-82-5	nc	HQ=1	6.65	mg/kg	LANL (2007, 094496)
Sediment	Aroclor-1260	11096-82-5	ca	risk=10 ⁻⁵	10.5	mg/kg	LANL (2007, 094496)
Sediment	Arsenic	7440-38-2	ca	risk=10 ⁻⁵	27.7	mg/kg	EPA (2007, 101002)
Sediment	Benzo(a)anthracene	56-55-3	ca	risk=10 ⁻⁵	30.1	mg/kg	LANL (2007, 094496)
Sediment	Benzo(a)pyrene	50-32-8	ca	risk=10 ⁻⁵	3.01	mg/kg	LANL (2007, 094496)
Sediment	Benzo(b)fluoranthene	205-99-2	ca	risk=10 ⁻⁵	30.1	mg/kg	LANL (2007, 094496)
Sediment	Cadmium	7440-43-9	nc	HQ=1	392	mg/kg	LANL (2007, 094496)
Sediment	Cesium-137	10045-97-3	rad ^c	15 mrem/yr	210	pCi/g	LANL (2005, 088493)
Sediment	Iron	7439-89-6	nc	HQ=1	100000	mg/kg	LANL (2007, 094496)
Sediment	Lead	7439-92-1	nc	HQ=1	560	mg/kg	LANL (2007, 094496)
Sediment	Manganese	7439-96-5	nc	HQ=1	15800	mg/kg	LANL (2007, 094496)
Sediment	Naphthalene	91-20-3	nc	HQ=1	15800	mg/kg	LANL (2007, 094496)
Sediment	Plutonium-239/240	15117-48-3	rad	15 mrem/yr	300	pCi/g	LANL (2005, 088493)
Sediment	Silver	7440-22-4	nc	HQ=1	3960	mg/kg	LANL (2007, 094496)
Sediment	TATB	3058-38-6	nc	HQ=1	199	mg/kg	LANL (2007, 094496) - TNT Surrogate
Sediment	Thallium	7440-28-0	nc	HQ=1	52.3	mg/kg	LANL (2007, 094496)
Sediment	Thorium-228	14274-82-9	rad	15 mrem/yr	77	pCi/g	LANL (2005, 088493)
Sediment	Thorium-232	7440-29-1	rad	15 mrem/yr	40	pCi/g	LANL (2005, 088493)
Sediment	Uranium (Calculated Total)	7440-61-1	nc	HQ=1	2380	mg/kg	LANL (2007, 094496)
Sediment	Uranium-238	13981-16-3	rad	15 mrem/yr	2100	pCi/g	LANL (2005, 088493)
Sediment	Vanadium	7440-62-2	nc	HQ=1	5550	mg/kg	LANL (2007, 094496)
Surface water	Aluminum	7429-90-5	nc	HQ=1	6320000	µg/L	LANL (2004, 087390)

Table 8.2-9 (continued)

Medium	COPC	CAS ID	End Point	Target Adverse- Effect Level	Recreational SSL	Units	Reference
Surface water	Ammonia as Nitrogen	7664-41-7	nc	HQ=1	183286	µg/L	LANL (2006, 094161), calculated
Surface water	Antimony	7440-36-0	nc	HQ=1	2386	µg/L	LANL (2006, 094161), calculated
Surface water	Arsenic	7440-38-2	ca	risk=10 ⁻⁵	98.3	µg/L	LANL (2004, 087390)
Surface water	Chloride	na ^d	nc	HQ=1	na	µg/L	na
Surface water	Chloroform	67-66-3	ca	risk=10 ⁻⁵	159	µg/L	LANL (2006, 094161), calculated
Surface water	DDD	72-54-8	ca	risk=10 ⁻⁵	90	µg/L	LANL (2006, 094161), calculated
Surface water	DDE	72-55-9	ca	risk=10 ⁻⁵	113	µg/L	LANL (2006, 094161), calculated
Surface water	DDT	50-29-3	ca	risk=10 ⁻⁵	25	µg/L	LANL (2006, 094161), calculated
Surface water	Dieldrin	60-57-1	ca	risk=10 ⁻⁵	4.51	µg/L	LANL (2006, 094161), calculated
Surface water	Fluoride	16984-48-8	nc	HQ=1	379000	µg/L	LANL (2004, 087390)
Surface water	Iron	7439-89-6	nc	HQ=1	1900000	µg/L	LANL (2004, 087390)
Surface water	Lead	7439-92-1	nc	HQ=1	65	µg/L	LANL (2004, 087390)
Surface water	Manganese	7439-96-5	nc	HQ=1	706000	µg/L	LANL (2004, 087390)
Surface water	Mercury	7487-94-7	nc	HQ=1	1660	µg/L	LANL (2004, 087390)
Surface water	radium-226	13982-63-3	rad	4 mrem/yr	757	µg/L	LANL (2006, 094161), calculated
Surface water	radium-228	15262-20-1	rad	4 mrem/yr	617	µg/L	LANL (2006, 094161), calculated
Surface water	RDX	121-82-4	ca	risk=10 ⁻⁵	59.7	µg/L	LANL (2006, 094161), calculated
Surface water	Sulfate	na	nc	HQ=1	na ^d	µg/L	Not available
Surface water	Thallium	7791-12-0	nc	HQ=1	506	µg/L	LANL (2004, 087390)
Surface water	Trichloroethene	79-01-6	ca	risk=10 ⁻⁵	330	µg/L	LANL (2006, 094161), calculated

^a nc= Noncarcinogen.

^b ca = Carcinogen.

^c rad = Radionuclide.

^d na = Not available.

**Table 8.2-10
Summary of Recreational Risk Assessment Results**

Reach	Carcinogenic ILCR			Noncarcinogenic Hazard Index			Total Radionuclide Dose		
	Sediment	Surface Water	Multimedia	Sediment	Surface Water	Multimedia	Sediment	Surface Water	Multimedia
AEN-1	3.3E-06	3.3E-07	4E-06	0.35	0.036	0.38	-*	-	-
AES-1	1.5E-06	-	-	0.33	-	-	-	-	-
AW-1	5.6E-06	-	-	0.61	-	-	-	-	-
PA-0	-	2.0E-07	-	-	0.017	-	0.41	-	-
PA-1E	1.0E-06	2.4E-07	1E-06	-	0.065	-	-	-	-
PA-1W	-	2.5E-07	-	-	0.046	-	-	0.035	-
PA-2W	-	1.6E-07	-	0.25	0.021	0.27	-	-	-
PA-3E	-	-	-	0.24	0.041	0.28	-	-	-
PA-4	1.9E-06	4.0E-07	2E-06	0.50	0.001	0.50	0.65	-	-
PA-5W	1.5E-06	-	-	0.39	-	-	-	-	-
PAS-1E	2.0E-06	-	-	0.36	-	-	-	-	-
PAS-2W	2.0E-06	-	-	-	-	-	-	-	-
TH-1C	1.0E-06	-	-	0.22	-	-	-	-	-
TH-1E	1.7E-06	-	-	0.43	-	-	-	-	-
TH-3	-	-	-	0.01	-	-	-	-	-
THW-1	1.2E-06	-	-	0.30	-	-	-	-	-
THS-1E	-	-	-	0.16	-	-	1.2	-	-
THS-1W	-	-	-	0.03	-	-	-	-	-
THW-1	-	-	-	0.19	-	-	-	-	-
TW-2E	-	1.5E-07	-	0.20	0.048	0.24	-	-	-
TW-3E	1.9E-06	2.0E-07	2E-06	-	-	-	-	-	-
TWN-1E ^b	1.0E-04	-	-	0.04	-	-	-	-	-
TWN-1W	1.2E-06	-	-	-	-	-	-	-	-
TWSE-1E	1.1E-06	-	-	0.28	-	-	-	-	-
TWSE-1W	1.4E-06	-	-	0.32	-	-	-	-	-
TWSW-1E	1.3E-06	-	-	0.16	-	-	-	-	-
TWSW-1W	1.6E-06	-	-	0.30	-	-	-	-	-

Note: Bold and shaded exceeds 10-5 carcinogenic risk.

^a - Incomplete pathway.

^b Risk driven by PAH results from single sample. Resampled and results not reproducible. If exclude single sample, then total carcinogenic risk <10-5 (see text for more information).

Table 8.2-11
Risk Ratios Based on Exposure Point Concentrations for
Sediment, Recreational Scenario

Carcinogens

Reach	Arsenic	Aroclor-1254	Aroclor-1260	Benzo[a]anthracene	Benzo[a]pyrene	Benzo[b]fluoranthene	Total Risk Ratio	Total ILCR
Recreational SSL (mg/kg)	27.7	10.5	10.5	30.1	3.01	30.1		
AEN-1	0.16	- ^a	-	-	0.17	-	0.33	3.3E-06
AES-1	0.15	-	-	-	-	-	0.15	1.5E-06
AW-1	0.32	0.071	0.027	0.010	0.12	0.013	0.56	5.6E-06
PA-1E	0.10	-	-	-	-	-	0.10	1.0E-06
PA-4	0.15	-	-	-	0.039	-	0.19	1.9E-06
PA-5W	0.12	-	-	-	0.030	-	0.15	1.5E-06
PAS-1E	0.20	-	-	-	-	-	0.20	2.0E-06
PAS-2W	0.13	-	-	-	0.062	-	0.20	2.0E-06
TH-1C	0.10	-	-	-	-	-	0.10	1.0E-06
TH-1E	0.17	-	-	-	-	-	0.17	1.7E-06
THW-1	0.12	-	-	-	-	-	0.12	1.2E-06
TW-3E	0.14	-	-	-	0.046	-	0.19	1.9E-06
TWN-1E ^b	-	-	-	1.3	8.8	0.026	10	1.0E-04
TWN-1W	0.12	-	-	-	-	-	0.12	1.2E-06
TWSE-1E	0.11	-	-	-	-	-	0.11	1.1E-06
TWSE-1W	0.14	-	-	-	-	-	0.14	1.4E-06
TWSW-1E	0.13	-	-	-	-	-	0.13	1.3E-06
TWSW-1W	0.16	-	-	-	-	-	0.16	1.6E-06

Table 8.2-11 (continued)

Noncarcinogens

Reach	Aluminum	Aroclor-1248	Aroclor-1254	Aroclor-1260	Cadmium	Iron	Lead	Manganese	Naphthalene	Silver	TATB	Thallium	Uranium (Calculated Total)	Vanadium	Hazard Index
Recreational SSL (mg/kg)	100000	6.65	6.65	6.65	392	100000	560	15800	15800	3960	199	52.3	2380	5550	
AEN-1	0.13	-	-	-	0.0067	0.12	-	0.034	-	-	0.022	0.023	0.0025	0.0050	0.35
AES-1	0.15	-	-	-	-	0.14	-	0.037	-	-	-	-	-	0.0045	0.33
AW-1	0.18	-	0.11	0.043	-	0.15	0.069	0.029	-	0.0090	-	-	0.0023	0.0079	0.61
PA-2W	0.10	-	-	-	-	0.11	-	0.031	-	-	-	-	0.0023	0.0032	0.25
PA-3E	0.11	-	-	-	-	-	0.061	0.064	-	-	-	-	-	0.0031	0.24
PA-4	0.18	-	-	-	-	0.18	0.048	0.10	-	-	-	-	-	0.0044	0.50
PA-5W	0.19	-	-	-	-	0.14	-	0.052	-	-	-	-	-	0.0043	0.39
PAS-1E	0.14	-	-	-	-	0.17	-	0.034	-	0.011	-	-	-	0.0053	0.36
TH-1C	-	-	-	-	-	0.14	-	0.072	-	-	-	-	0.0043	-	0.22
TH-1E	0.20	-	-	-	-	0.17	-	0.049	-	-	-	-	0.0066	0.0048	0.43
TH-3	-	-	-	-	-	-	-	-	-	-	-	-	0.0086	-	0.0086
THM-1	-	-	-	-	-	0.13	0.110	-	-	-	-	-	0.060	-	0.30
THS-1E	-	-	-	-	-	0.14	-	-	-	-	-	-	0.023	-	0.16
THS-1W	-	-	-	-	-	-	-	-	-	-	-	-	0.029	-	0.029
THW-1	0.15	-	-	-	-	-	-	0.026	-	-	-	-	0.0062	0.0037	0.19
TW-2E	-	0.023	-	-	-	0.15	-	0.024	-	-	-	-	-	0.0027	0.20
TWN-1E	-	-	-	-	-	-	-	0.036	0.0027	-	-	-	-	-	0.039
TWSE-1E	0.11	-	-	-	-	0.12	-	0.042	-	-	-	-	-	0.0031	0.28
TWSE-1W	0.17	-	-	-	-	0.15	-	-	-	-	-	-	-	0.0052	0.32
TWSW-1E	0.10	-	-	-	-	-	-	0.058	-	-	-	-	0.0027	0.0040	0.16
TWSW-1W	0.16	-	-	-	-	0.14	-	-	-	-	-	-	-	0.0044	0.30

Table 8.2-11 (continued)

Radionuclides

Reach	Cesium-137	Plutonium-239/240	Thorium-228	Thorium-232	Uranium-238	Total Dose Ratio	Total Dose
Recreational SALs (pCi/g)	210	300	77	40	2100		
PA-0	0.015	0.013	-	-	-	0.028	0.11
PA-4	0.020	-	0.024	-	-	0.044	0.17
THS-1E	-	-	0.026	0.043	0.0086	0.078	0.31

Notes: Sources of SSLs and SALs are presented in Table 8.2-9. All values from EPA Region 6 HHSSLs and Region 9 PRGs adjusted to TR 10^{-5} . Shaded cells risk ratio greater than 1.

^a - = Incomplete pathway.

^b Risk driven by PAH results from single sample. Resampled and results not reproducible. If exclude single sample then total carcinogenic risk $<10^{-5}$ (see text for more information).

**Table 8.2-12
Risk Ratios Based on Exposure Point Concentrations for Surface Water, Recreational Scenario**

Carcinogens

Location	Reach	Arsenic	Benzo(b)fluoranthene (1)	Benzo(k)fluoranthene (1)	Chloroform	DDD[4,4'] (1)	DDE[4,4']	DDT[4,4'] (1)	Dieldrin	RDX	Trichloroethene	Total Risk Ratio	Total Risk
Recreational SW SSL (µg/L)		98.3	24.1	254	159	160	113	113	4.51	1350	330		
Anderson Spring	na ^a	0.026	- ^b	-	0.0024	-	-	-	-	-	-	0.029	2.9E-07
Bulldog Spring	na	0.016	-	-	-	0.00015	0.00019	0.00015	0.0017	0.0032	0.0011	0.023	2.3E-07
Charlie's Spring	na	0.016	-	-	-	-	-	-	-	-	-	0.016	1.6E-07
Homestead Spring	PA-1W	0.025	-	-	-	-	-	-	-	-	-	0.025	2.5E-07
Kieling Spring	na	0.019	-	-	-	-	-	-	-	-	-	0.019	1.9E-07
La Delfe above Pajarito	AEN-1	0.032	-	-	-	-	-	-	-	0.0011	-	0.033	3.3E-07
Pajarito 0.5 mi above SR-501	PA-0	0.020	-	-	-	-	-	-	-	-	-	0.020	2.0E-07
Pajarito above SR-4	PA-4	0.040	-	-	-	-	-	-	-	-	-	0.040	4.0E-07
Pajarito above Starmers	PA-1W	0.023	-	-	-	-	-	-	-	-	-	0.023	2.3E-07
Pajarito above Twomile	PA-2W	0.016	-	-	-	-	-	-	-	-	-	0.016	1.6E-07
Pajarito below confluences of South and North Anchor East Basin	PA-1E	0.023	-	-	-	-	-	-	-	0.00053	-	0.024	2.4E-07
PC Spring	na ^b	0.017	-	-	-	-	-	-	-	-	-	0.017	1.7E-07
Spring 4	na	0.046	0.298	0.0020	-	-	-	-	-	-	-	0.346	3.5E-06
Spring 4A	na	0.039	-	-	-	-	-	-	-	-	-	0.039	3.9E-07

Table 8.2-12 (continued)

Carcinogens

Location	Reach	Arsenic	Benzo(b)fluoranthene (1)	Benzo(k)fluoranthene (1)	Chloroform	DDD[4,4'] (1)	DDE[4,4']	DDT[4,4'] (1)	Dieldrin	RDX ¹	Trichloroethene	Total Risk Ratio	Total Risk
Spring 4AA	na	0.043	-	-	-	-	-	-	-	-	-	0.043	4.3E-07
Spring 4B	na	0.034	-	-	-	-	-	-	-	-	-	0.034	3.4E-07
Spring 4C	na	0.041	-	-	-	-	-	-	-	-	-	0.041	4.1E-07
Starmer Spring	na	0.020	-	-	-	-	-	-	-	-	-	0.020	2.0E-07
Starmers above Pajarito	na	0.031	-	-	-	-	-	-	-	-	-	0.031	3.1E-07
TW-1.72 Spring	TW-2E	0.015	-	-	-	-	-	-	-	-	-	0.015	1.5E-07
Two Mile below TA-59	TW-3E	0.020	-	-	-	-	-	-	-	-	-	0.020	2.0E-07

Table 8.2-12 (continued)

Noncarcinogens

Location	Reach	Aluminum	Ammonia as Nitrogen	Antimony	Chloride	Fluoride	Iron	Lead	Manganese	Mercury	Sulfate	Thallium	Hazard Index
Recreational SW SSL (μ /L)		6320000	183286	2386	na	379000	1900000	65	706000	1660	na	506	
Anderson Spring	na	0.0015	0.00063	-	-	0.00077	0.0028	0.0394	-	-	-	0.00076	0.046
Bulldog Spring	na	0.0010	0.00023	-	na	0.00076	0.0018	0.0439	-	-	-	0.00064	0.048
Charlie's Spring	na	0.0020	-	-	na	-	0.0032	0.0412	-	0.00007	-	0.0012	0.048
Homestead Spring	PA-1W	0.0014	0.00026	-	-	-	0.0026	0.0405	-	0.00022	-	0.0013	0.046
Kieling Spring	na	0.0022	0.00028	-	na	-	0.0036	0.0540	-	0.000062	-	0.0011	0.061
La Delfe above Pajarito	AEN-1	0.00092	-	-	-	-	0.0015	0.0323	-	-	-	0.00093	0.036
Pajarito 0.5 mi above SR-501	PA-0	0.00094	0.00073	-	-	-	0.0014	0.0137	-	-	-	0.00066	0.017
Pajarito above SR-4	PA-4	-	-	-	-	-	-	-	-	-	-	0.0010	0.0010
Pajarito above Starmers	PA-1W	-	-	-	-	-	-	-	0.00039	-	-	-	0.00039
Pajarito above TA-18	PA-3E	0.0011	-	-	-	-	0.0019	0.0385	-	-	-	-	0.041
Pajarito above Threemile	na	0.0011	-	-	-	-	0.0019	0.0446	-	-	-	-	0.048
Pajarito above Twomile	PA-2W	0.00058	0.00028	-	na	0.00047	0.00091	0.0185	-	-	-	0.00067	0.021
Pajarito at Rio Grande	na	-	-	-	-	0.0012	-	-	-	-	-	0.00091	0.0022
Pajarito below confluences of South and North Anchor East Basin	PA-1E	0.0014	0.00035	-	-	-	0.0026	0.0600	-	-	-	0.0010	0.065
PC Spring	na	0.00034	0.0010	-	-	-	-	-	-	-	-	0.0010	0.0024
Spring 4	na	-	-	-	-	0.0012	-	-	-	-	-	-	0.0012
Spring 4A	na	-	-	-	-	0.0012	-	-	-	-	-	0.00085	0.0021

Table 8.2-12 (continued)

Noncarcinogens

Location	Reach	Aluminum	Ammonia as Nitrogen	Antimony	Chloride	Fluoride	Iron	Lead	Manganese	Mercury	Sulfate	Thallium	Hazard Index
Spring 4AA	na	-	-	-	-	0.0014	-	-	-	-	-	0.00063	0.0020
Spring 4B	na	-	-	-	-	0.0013	-	-	-	0.00052	-	0.00093	0.0027
Spring 4C	na	-	-	-	-	0.0013	-	-	-	-	-	-	0.0013
Starmer Spring	na	0.0011	0.00047	-	-	-	0.0020	0.0365	-	-	-	0.0012	0.041
Starmers above Pajarito	na	0.00076	-	-	-	-	0.0012	0.0246	-	0.000046	-	-	0.027
TA-18 Spring	na	0.00070	-	-	-	-	0.0012	-	0.00024	-	na	0.00089	0.0031
Threemile Spring	na	-	-	-	-	-	-	-	-	-	-	0.00085	0.00085
TW-1.72 Spring	TW-2E	0.0014	-	0.0021	na	0.00063	0.0025	0.0415	-	-	-	-	0.048
Two Mile below TA-59	TW-3E	0.00084	0.011	-	na	0.00068	0.0032	0.0335	-	-	-	0.0010	0.050

Table 8.2-12 (continued)

Radionuclides

Location	Reach	Radium-226	Radium-228	Total Dose Ratio	Total Dose
Recreational SW SAL (pCi/L)		758	617		
Homestead Spring	PA-1W	0.0036	0.0051	0.0087	0.035

Notes: Sources of SSLs and SALs are presented in Table 8.2-9. 1 = Toxicity-based medium-specific screening level is higher than water solubility.

^a na = SSL not available; ratio not calculated.

^b = Incomplete pathway.

Table 8.2-13
Exposure Point Concentrations for Sediment COPCs, Recreational Scenario

Reach	Carcinogens (mg/kg)					
	Arsenic	Aroclor-1254	Aroclor-1260	Benzo[a]anthracene	Benzo[a]pyrene	Benzo[b]fluoranthene
AEN-1	4.39	-*	-	-	0.511	-
AES-1	4.06	-	-	-	-	-
AW-1	8.95	0.748	0.283	0.314	0.360	0.404
PA-0	-	-	-	-	-	-
PA-1E	2.89	-	-	-	-	-
PA-2W	-	-	-	-	-	-
PA-3E	-	-	-	-	-	-
PA-4	4.27	-	-	-	0.119	-
PA-5W	3.44	-	-	-	0.0912	-
PAS-1E	5.62	-	-	-	-	-
PAS-2W	3.69	-	-	-	0.187	-
TH-1C	2.81	-	-	-	-	-
TH-1E	4.61	-	-	-	-	-
TH-3	-	-	-	-	-	-
THM-1	-	-	-	-	-	-
THS-1E	-	-	-	-	-	-
THS-1W	-	-	-	-	-	-
THW-1	3.30	-	-	-	-	-
TW-2E	-	-	-	-	-	-
TW-3E	3.98	-	-	-	0.140	-
TWN-1E	-	-	-	39.4	26.5	0.778
TWSE-1E	3.06	-	-	-	-	-
TWSE-1W	3.95	-	-	-	-	-
TWSW-1E	3.66	-	-	-	-	-
TWSW-1W	4.54	-	-	-	-	-

Table 8.2-13 (continued)

Reach	Noncarcinogens (mg/kg)													
	Aluminum	Aroclor-1248	Aroclor-1254	Aroclor-1260	Cadmium	Iron	Lead	Manganese	Naphthalene	Silver	TATB	Thallium	Uranium (Calculated Total)	Vanadium
AEN-1	13103	-	-	-	2.63	12115	-	532	-	-	4.37	1.23	5.91	27.7
AES-1	15022	-	-	-	-	13583	-	577	-	-	-	-	-	25.1
AW-1	17832	-	0.748	0.283	-	15453	38.8	455	-	35.51	-	-	5.36	44.0
PA-0	-	-	-	-	-	-	-	-	-	-	-	-	-	-
PA-1E	-	-	-	-	-	-	-	-	-	-	-	-	-	-
PA-2W	9953	-	-	-	-	11409	-	486	-	-	-	-	5.43	17.9
PA-3E	11490	-	-	-	-	-	34.0	1013	-	-	-	-	-	17.0
PA-4	17548	-	-	-	-	17506	26.8	1572	-	-	-	-	-	24.6
PA-5W	19386	-	-	-	-	14427	-	817	-	-	-	-	-	24.0
PAS-1E	13742	-	-	-	-	17411	-	538	-	44.90	-	-	-	29.5
PAS-2W	-	-	-	-	-	-	-	-	-	-	-	-	-	-
TH-1C	-	-	-	-	-	14296	-	1141	-	-	-	-	10.3	-
TH-1E	20062	-	-	-	-	17157	-	772	-	-	-	-	15.7	26.7
TH-3	-	-	-	-	-	-	-	-	-	-	-	-	20.5	-
THM-1	-	-	-	-	-	12673	61.8	-	-	-	-	-	142	-
THS-1E	-	-	-	-	-	13913	-	-	-	-	-	-	54.0	-
THS-1W	-	-	-	-	-	-	-	-	-	-	-	-	69.6	-
THW-1	15306	-	-	-	-	-	-	416	-	-	-	-	14.7	20.6
TW-2E	-	0.152	-	-	-	14614	-	386	-	-	-	-	-	14.7
TW-3E	-	-	-	-	-	-	-	-	-	-	-	-	-	-
TWN-1E	-	-	-	-	-	-	-	575	42.7	-	-	-	-	-
TWSE-1E	11056	-	-	-	-	12420	-	660	-	-	-	-	-	17.5
TWSE-1W	16692	-	-	-	-	14765	-	-	-	-	-	-	-	29.0
TWSW-1E	9641	-	-	-	-	-	-	918	-	-	-	-	6.43	22.3
TWSW-1W	16395	-	-	-	-	13636	-	-	-	-	-	-	-	24.6

Table 8.2-13 (continued)

Reach	Radionuclides (pCi/g)				
	Cesium-137	Plutonium-239/240	Thorium-228	Thorium-232	Uranium-238
AEN-1	-	-	-	-	-
AES-1	-	-	-	-	-
AW-1	-	-	-	-	-
PA-0	3.16	3.75	-	-	-
PA-1E	-	-	-	-	-
PA-2W	-	-	-	-	-
PA-3E	-	-	-	-	-
PA-4	4.18	-	1.82	-	-
PA-5W	-	-	-	-	-
PAS-1E	-	-	-	-	-
PAS-2W	-	-	-	-	-
TH-1C	-	-	-	-	-
TH-1E	-	-	-	-	-
TH-3	-	-	-	-	-
THM-1	-	-	-	-	-
THS-1E	-	-	1.99	1.73	18.1
THS-1W	-	-	-	-	-
THW-1	-	-	-	-	-
TW-2E	-	-	-	-	-
TW-3E	-	-	-	-	-
TWN-1E	-	-	-	-	-
TWSE-1E	-	-	-	-	-
TWSE-1W	-	-	-	-	-
TWSW-1E	-	-	-	-	-
TWSW-1W	-	-	-	-	-

*- = Incomplete pathway.

**Table 8.2-14
Exposure Point Concentrations for Surface Water COPCs, Recreational Scenario**

Location	Reach	Carcinogens (ug/L)									
		Arsenic	Benzo(b)fluoranthene	Benzo(k)fluoranthene	Chloroform	DDD[4,4']	DDE[4,4']	DDT[4,4']	Dieldrin	RDX	Trichloroethene
Anderson Spring	n/a ^a	2.60	- ^b	-	0.389	-	-	-	-	-	-
Bulldog Spring	n/a	1.60	-	-	-	0.0233	0.0220	0.0173	0.00767	4.30	0.351
Charlie's Spring	n/a	1.58	-	-	-	-	-	-	-	-	-
Homestead Spring	PA-1W	2.48	-	-	-	-	-	-	-	-	-
Kieling Spring	n/a	1.91	-	-	-	-	-	-	-	-	-
La Delfe above Pajarito	AEN-1	3.10	-	-	-	-	-	-	-	1.50	-
Pajarito 0.5 mi above SR-501	PA-0	2.00	-	-	-	-	-	-	-	-	-
Pajarito above SR-4	PA-4	3.90	-	-	-	-	-	-	-	-	-
Pajarito above Starmers	PA-1W	2.30	-	-	-	-	-	-	-	-	-
Pajarito above TA-18	PA-3E	-	-	-	-	-	-	-	-	-	-
Pajarito above Threemile	n/a	-	-	-	-	-	-	-	-	-	-
Pajarito above Twomile	PA-2W	1.60	-	-	-	-	-	-	-	-	-
Pajarito at Rio Grande	n/a	-	-	-	-	-	-	-	-	-	-
Pajarito below confluences of South and North Anchor East Basin	PA-1E	2.30	-	-	-	-	-	-	-	0.714	-
PC Spring	n/a	1.71	-	-	-	-	-	-	-	-	-
Spring 4	n/a	4.49	7.20	0.500	-	-	-	-	-	-	-
Spring 4A	n/a	3.82	-	-	-	-	-	-	-	-	-
Spring 4AA	n/a	4.19	-	-	-	-	-	-	-	-	-

Table 8.2-14 (continued)

Location	Reach	Carcinogens (ug/L)									
		Arsenic	Benzo(b)fluoranthene	Benzo(k)fluoranthene	Chloroform	DDD[4,4'-]	DDE[4,4'-]	DDT[4,4'-]	Dieldrin	RDX	Trichloroethene
Spring 4B	n/a	3.36	-	-	-	-	-	-	-	-	-
Spring 4C	n/a	4.05	-	-	-	-	-	-	-	-	-
Starmer Spring	n/a	2.00	-	-	-	-	-	-	-	-	-
Starmers above Pajarito	n/a	3.00	-	-	-	-	-	-	-	-	-
TA-18 Spring	n/a	-	-	-	-	-	-	-	-	-	-
Threemile Spring	n/a	-	-	-	-	-	-	-	-	-	-
TW-1.72 Spring	TW-2E	1.50	-	-	-	-	-	-	-	-	-
Two Mile below TA-59	TW-3E	1.96	-	-	-	-	-	-	-	-	-

Table 8.2-14 (continued)

Location	Non-Carcinogens (ug/L)											Radionuclides (pCi/L)	
	Aluminum	Ammonia as Nitrogen	Antimony	Chloride	Fluoride	Iron	Lead	Manganese	Mercury	Sulfate	Thallium	Radium-226	Radium-228
Anderson Spring	9200	115	-	-	293	5230	2.56	-	-	-	0.385	-	-
Bulldog Spring	6596	41.4	-	23439	287	3381	2.85	-	-	-	0.322	-	-
Charlie's Spring	12614	-	-	19893	-	6070	2.68	-	0.120	-	0.590	-	-
Homestead Spring	8968	47.0	-	-	-	4960	2.63	-	0.370	-	0.680	2.72	3.13
Kieling Spring	13900	51.5	-	18577	-	6920	3.51	-	0.103	-	0.560	-	-
La Delfe above Pajarito	5834	-	-	-	-	2816	2.10	-	-	-	0.470	-	-
Pajarito 0.5 mi above SR-501	5910	134	-	-	-	2686	0.890	-	-	-	0.333	-	-
Pajarito above SR-4	-	-	-	-	-	-	-	-	-	-	0.500	-	-
Pajarito above Starmers	-	-	-	-	-	-	-	276	-	-	-	-	-
Pajarito above TA-18	6670	-	-	-	-	3610	2.50	-	-	-	-	-	-
Pajarito above Threemile	7040	-	-	-	-	3560	2.90	-	-	-	-	-	-
Pajarito above Twomile	3634	50.7	-	18510	177	1730	1.20	-	-	-	0.338	-	-
Pajarito at Rio Grande	-	-	-	-	471	-	-	-	-	-	0.460	-	-
Pajarito below confluences of South and North Anchor East Basin	9143	63.8	-	-	-	4932	3.90	-	-	-	0.530	-	-
PC Spring	2165	190	-	-	-	-	-	-	-	-	0.520	-	-
Spring 4	-	-	-	-	469	-	-	-	-	-	-	-	-

Table 8.2-14 (continued)

Location	Non-Carcinogens (ug/L)											Radionuclides (pCi/L)	
	Aluminum	Ammonia as Nitrogen	Antimony	Chloride	Fluoride	Iron	Lead	Manganese	Mercury	Sulfate	Thallium	Radium-226	Radium-228
Spring 4A	-	-	-	-	462	-	-	-	-	-	0.430	-	-
Spring 4AA	-	-	-	-	515	-	-	-	-	-	0.320	-	-
Spring 4B	-	-	-	-	483	-	-	-	0.870	-	0.470	-	-
Spring 4C	-	-	-	-	485	-	-	-	-	-	-	-	-
Starmer Spring	7212	86.0	-	-	-	3714	2.37	-	-	-	0.590	-	-
Starmers above Pajarito	4823	-	-	-	-	2282	1.60	-	0.0760	-	-	-	-
TA-18 Spring	4420	-	-	-	-	2370	-	170	-	24576	0.450	-	-
Threemile Spring	-	-	-	-	-	-	-	-	-	-	0.430	-	-
TW-1.72 Spring	9090	-	4.90	93500	237	4720	2.70	-	-	-	-	-	-
Two Mile below TA-59	5337	1960	-	125528	257	6120	2.18	-	-	-	0.500	-	-

^a n/a = Not applicable, not in any reach.

^b - = Incomplete pathway.

Appendix A

*Acronyms and Abbreviations,
Metric Conversion Table, and Data Qualifier Definitions*

A-1.0 ACRONYMS AND ABBREVIATIONS

%D	percent difference
%R	percent recovery
%RSD	percent standard deviation
‰	per mil
ALLH	all horizons
AO	Administrative Order
AOC	area of concern
asl	above sea level
ASTM	American Society for Testing and Materials
BCG	Biota Concentration Guide (DOE)
bgs	below ground surface
BV	background value
bw	body weight
CAH	chlorinated aliphatic hydrocarbon
CCV	continuous calibration verification
CD	compact disk
CDF	cumulative distribution functions
cfs	cubic foot per second
Consent Order	Compliance Order on Consent
COPC	chemical of potential concern
COPEC	chemical of potential ecological concern
cps	count per second
CR	concentration ratio
CRDL	contract-required detection limit
CWA	Clean Water Act
D&D	decontamination and decommissioning
DC	direct current

DCA	dichloroethane
DCE	dichlorethylene
DCF	dose conversion factor
DCG	Derived Concentration Guidelines (DOE)
DOE	Department of Energy (U.S.)
DRI	Desert Research Institute
ECDF	empirical cumulative distribution function
ED	exposure duration
EPA	Environmental Protection Agency (U.S.)
EPC	exposure point concentration
EQL	estimated quantitation limit
ER	Environmental Restoration
ERAGS	Ecological Risk Assessment Guidance for Superfund
ERDB	Environmental Restoration Database
ESL	ecological screening level
ESP	Environmental Surveillance Program
ET	evapotranspiration
FFCA	Federal Facility Compliance Agreement
fpm	foot per minute
FR	Federal Register
FRS	flood retention structure
fw	fresh weight
GFM	geologic framework model
HA	hand auger
HE	high explosives
HHMSSL	Human Health Medium-Specific Screening Level (EPA Region 6)
HI	hazard index
HMX	octahydro-1,3,5,7-tetranitro-1,3,5,7-tetrazocine

HQ	hazard quotient
HSA	hollow-stem auger
ICPES	inductively coupled plasma emission spectroscopy
ICR	incremental cancer risk
ICV	initial calibration verification
IS	internal standard
I.D.	inside diameter
ILCR	incremental lifetime cancer risk
IFGMP	“Interim Facility-Wide Groundwater Monitoring Plan”
LAL	lower acceptance limit
LANL	Los Alamos National Laboratory
LANS	Los Alamos National Security, LLC
LCS	laboratory control sample
L/min	liter per minute
LOAEL	lowest observed adverse effect level
MCL	maximum contaminant levels (EPA)
MDA	material disposal area
MDL	method detection limit
mrem/yr	millirem per year
MS	matrix spike
MSD	matrix spike duplicate
MSGP	Multi-Sector General Permit
mV	millivolt
NMAC	New Mexico Administrative Code
NMED	New Mexico Environment Department
NMEIB	New Mexico Environmental Improvement Board
NMHWA	New Mexico Hazardous Waste Act
NMSA	New Mexico Statutes Annotated

NMWQCC	New Mexico Water Quality Control Commission
NOAEL	no observed adverse effect level
NOD	notice of disapproval
NPDES	National Pollutant Discharge Elimination System
NTS	Nevada Test Site
OB	Oversight Bureau (New Mexico)
O.D.	outside diameter
PAH	polycyclic aromatic hydrocarbon
PCB	polychlorinated biphenyl
PCE	perchloroethylene
PID	photoionization detector
PQL	practical quantitation limit
PRG	preliminary remediation goal
QA	quality assurance
QC	quality control
RCRA	Resource Conservation and Recovery Act
RDX	hexahydro-1,3,5-trinitro-1,3,5-triazine
RL	reporting limit
RME	reasonable maximum exposure
RPD	relative percent difference
RSD	relative standard deviation
SAL	screening action level
SCI	Stream Condition Index
SF	slope factor
SLERA	screening-level ecological risk assessment
SMCL	Secondary Maximum Contaminant Level(EPA)
SOF	sum of fraction
SOP	standard operating procedure

SOW	statement of work
SSL	soil screening level
SVOC	semivolatile organic compound
SWMU	solid waste management unit
T&E	threatened and endangered
TA	technical area
TATB	triaminotrinitrobenzene
TCA	1,1,1-trichloroethane
TCDD	tetrachlorodibenzodioxin
TCDF	tetrachlorodibenzofuran
TCE	trichloroethene
TD	total depth
TF	transfer factor
TNT	2,4,6-trinitrotoluene
TOC	total organic compound
TPH-DRO	total propagated hydrocarbon-diesel range organics
TPU	total propagated uncertainty
TRV	toxicity reference value
UAL	upper acceptance limit
UC	University of California
UCL	upper confidence limit
UDR	universal drill rig
USGS	U.S. Geological Survey
UTL	upper tolerance limit
VCA	voluntary corrective action
VOC	volatile organic compound
WHO	World Health Organization
WOE	weight of evidence

WQC	water-quality criteria
WQDB	Water Quality Database
wSAL	water screening level

A-2.0 METRIC CONVERSION TABLE

Multiply SI (Metric) Unit	by	To Obtain US Customary Unit
kilometers (km)	0.622	miles (mi)
kilometers (km)	3281	feet (ft)
meters (m)	3.281	feet (ft)
meters (m)	39.37	inches (in.)
centimeters (cm)	0.03281	feet (ft)
centimeters (cm)	0.394	inches (in.)
millimeters (mm)	0.0394	inches (in.)
micrometers or microns (μm)	0.0000394	inches (in.)
square kilometers (km^2)	0.3861	square miles (mi^2)
hectares (ha)	2.5	acres
square meters (m^2)	10.764	square feet (ft^2)
cubic meters (m^3)	35.31	cubic feet (ft^3)
kilograms (kg)	2.2046	pounds (lb)
grams (g)	0.0353	ounces (oz)
grams per cubic centimeter (g/cm^3)	62.422	pounds per cubic foot (lb/ft^3)
milligrams per kilogram (mg/kg)	1	parts per million (ppm)
micrograms per gram ($\mu\text{g}/\text{g}$)	1	parts per million (ppm)
liters (L)	0.26	gallons (gal.)
milligrams per liter (mg/L)	1	parts per million (ppm)
degrees Celsius ($^{\circ}\text{C}$)	$9/5 + 32$	degrees Fahrenheit ($^{\circ}\text{F}$)

A-3.0 DATA QUALIFIER DEFINITIONS

Data Qualifier	Definition
U	The analyte was analyzed for but not detected.
J	The analyte was positively identified, and the associated numerical value is estimated to be more uncertain than would normally be expected for that analysis.
J+	The analyte was positively identified, and the result is likely to be biased high.
J-	The analyte was positively identified, and the result is likely to be biased low.
UJ	The analyte was not positively identified in the sample, and the associated value is an estimate of the sample-specific detection or quantitation limit.
R	The data are rejected as a result of major problems with quality assurance/quality control (QA/QC) parameters.

Appendix B

Field Investigation Methods and Results

B-1.0 SEDIMENT INVESTIGATIONS IN REACHES

This appendix summarizes methods and results from field investigations of potentially contaminated sediment deposits in reaches within the Pajarito watershed that were conducted from 2000 to 2007 as part of implementation of the "Work Plan for Pajarito Canyon" (LANL 1998, 059577; LANL 2005, 091287). Investigations associated with evaluating potential adverse ecological impacts are presented separately in Section B-3.0 of this appendix.

Geomorphic mapping at a scale of 1:200 occurred in each reach and focused on delineating geomorphic units with differences in physical characteristics and/or contaminant levels. These maps are presented on Plates 2 to 6. Unit designations followed those used in previous reports on canyons in and near the Los Alamos National Laboratory (LANL or the Laboratory) (e.g., LANL 2004, 087390; LANL 2006, 094161), with "c" designating post-1942 channel units and "f" designating post-1942 floodplain units. Summaries of the physical characteristics of post-1942 geomorphic units in the Pajarito investigation reaches are presented in Table B-1.0-1.

Sediment thickness measurements distinguished between fine facies sediment, with typical median particle size of silt to fine sand (0.015 to 0.25 mm) in the less than 2-mm fraction, and coarse facies sediment, with typical median particle size of coarse to very coarse sand (0.5 to 2 mm) in the less than 2-mm fraction. Samples with median particle size of medium sand (0.25 to 0.5 mm) were classified either as fine or coarse facies, depending on the stratigraphic context and the particle size of adjacent layers. Coarse facies sediment is characteristic of material transported along the streambeds as bed load, and fine facies sediment is characteristic of material transported in suspension (Malmon 2002, 076038, pp. 94-97; Malmon et al. 2004, 093018). Several methods were used to identify the bottom of post-1942 sediment deposits, including determining the depth of buried trees and associated buried soils and noting the presence or absence of materials imported to the watershed after 1942 (e.g., quartzite gravel and plastic). Sediment thickness measurements from the Pajarito investigation reaches are shown in Table B-1.0-2.

Average facies thickness in each unit was combined with unit area, as determined from digitized geomorphic maps, to obtain an estimated unit volume. The estimates of unit volume were combined with estimates of contaminant levels, where available, to allocate samples using a stratified sample allocation process (Gilbert 1987, 056179, pp. 45-57) designed to reduce uncertainties in the contaminant inventory in each reach. In this process, samples were preferentially allocated to units and sediment facies with a large portion of the total inventory (e.g., Ryti et al. 2005, 093019). One result of this sample allocation process is a high bias in sample results because a disproportionately large number of samples were collected from the more contaminated geomorphic units and sediment facies.

Particle-size analyses of sediment samples were obtained at an off-site laboratory at the Desert Research Institute (DRI) following the procedures described in Janitzky (1986, 057674) to examine the effect of particle-size distribution on contaminant concentrations. Organic-matter content was also determined for sediment samples at DRI using the loss-on-ignition method to provide additional information about the physical characteristics of potentially contaminated sediment deposits, and pH data were also obtained because ecological screening levels can be pH-dependant for some analytes. Particle size, organic matter, and pH from the Pajarito investigation reaches are shown in Table B-1.0-3.

B-2.0 WATER INVESTIGATIONS

Water-Level Measurements

To address the requirement of Section IX.B.2.h.i of the Compliance Order on Consent (the Consent Order) to measure groundwater levels in all wells in a given watershed within 24 h, automated pressure transducers are installed in all sampled wells. These data are available for any 24-h period and therefore meet the requirement for these measurements to be completed across all watersheds within 14 d of the commencement of the specified water-level measuring event as required by the Consent Order. The Laboratory's standard operating procedures for use of transducers require field verification of the transducer data with periodic manual measurements. Measurement of water levels follows the procedures listed in Appendix C, Table C-1, of the "2008 Interim Facility-Wide Groundwater Monitoring Plan" (IFGMP) (LANL 2008, 101897). All of the procedures are available on the Laboratory's website <http://erproject.lanl.gov/documents/procedures/qps.html>. Water-level measurements are presented in Appendix C and discussions of water levels are included in Appendixes I and L.

Surface Water and Springs

Sampling activities included monitoring of 6 surface-water base-flow locations and 10 springs. The list of surface-water and spring sampling sites is presented in Table 3.2-1. Figure 3.2-1 shows the locations of the sample sites listed in Table 3.2-1. Analytical results for surface-water and spring samples are presented in Appendix C of this report. Temporal and spatial trends for these results are shown in Appendix D.

Field methods followed the procedures listed in Appendix C, Tables C-2 and C-3, of the IFGMP (LANL 2008, 101897). Field procedures follow guidelines from U.S. Geological Survey (USGS) water-sample collection methods and industrial standards common to environmental sample collection and field measurements. Quality control (QC) samples include laboratory blanks, spikes, and replicates.

For chemical analysis of water samples, the Laboratory uses commonly accepted analytical methods that are called for under federal regulations (such as the Clean Water Act [CWA]) and that are approved by the U.S. Environmental Protection Agency (EPA). Analytical methods and method detection limits are provided in Appendix C, Table C.4, of the IFGMP (LANL 101897).

Alluvial Wells

Boreholes were drilled at five hand auger (HA) locations and nine hollow-stem auger (HSA) locations in accordance with the "Drilling Plan for Pajarito and Rendija Canyons Alluvial Wells" (TerraNearPMC 2008, 102316). Appendix G of this report describes drilling methods for individual wells, well completion diagrams, and geologic logs for the new wells and boreholes. The purpose of this work was to collect cores and cutting samples for chemical analysis and to install alluvial monitoring wells in the Pajarito Canyon watershed. Data collected from the monitoring wells are used to provide hydrogeology and groundwater-quality data. HA and HSA drilling began March 20, 2008, and well installation was completed on June 11, 2008.

HSA drilling was conducted using a CME 75 HSA, track-mounted drill rig. Analytical samples were collected by split-spoon sampler every 10 ft beginning at 10 ft below ground surface (bgs) and at the base of alluvium. HA analytical samples were collected every 5 ft beginning at 5 ft bgs and at the base of the alluvium. Drill cuttings were field screened for volatile organic compounds (VOCs) and radioactivity, visually inspected, and geologically logged. A MiniRae 200 photoionization detector (PID) was used to screen for VOCs, and an Eberline ESP-1 (with an HP260 probe) was used to screen for beta/gamma

radioactivity. The PID was calibrated daily by the project site safety officer, and the ESP-1 was calibrated daily by a Laboratory radiological control technician.

Abandoned HSA boreholes were backfilled with bentonite chips to within 2 ft of the surface, hydrated, and then sealed with Portland cement to the surface, as described in the approved drilling plan (LANL 2008, 102316). Abandoned HA boreholes were backfilled with bentonite chips to within 1 ft of the surface, hydrated and then covered with surrounding soil.

Analytical results for core and water samples collected as part of the alluvial wells investigation are presented in Appendix C of this report.

Characterization Core Holes

Characterization core holes were drilled as part of the installation of regional wells R-17, R-20, and R-32. Table 3.2-1 describes the core holes and provides information about their locations, purpose, and depths. Descriptions of coring activities and geologic logs are provided in the well completion reports for the associated regional wells. Analytical results for core samples collected as part of these investigations are presented in Appendix C of this report. Vadose-zone profiles for selected contaminants are presented in Appendix H.

The R-17 core hole was drilled by Spectrum Exploration, Inc., between November 2 and 18, 2005, using a Delta Base 540 track-mounted HQ coring rig to a total depth (TD) of 300.9 ft bgs. Core recovery was intermittent, but core samples were generally collected as specified in the drilling work plan. Core was collected with a 3.9-in. inside diameter (I.D.) core barrel to 232.9 ft bgs. Drillers switched to a 2-in. outside diameter (O.D.) split-spoon sampler below 232.9 ft bgs in an effort to improve core recovery. Core samples were collected for laboratory analysis every 10 ft to a depth of 100 ft bgs and at 50-ft intervals thereafter. A total of 12 samples were collected for contaminant characterization.

The R-20 core hole was first attempted by the Stewart Brothers, who drilled with a failing F-10 auger rig equipped with 4.25-in.-I.D., 9-in.-O.D. HSAs. The HSAs were equipped with a wireline core retrieval system capable of collecting 3-in.-diameter × 5-ft-long core samples. Coring began on August 4, 2002. While coring through 68 ft of alluvium, the auger flights jammed several times after coring down to only 72.5 ft bgs by August 8, 2002. The Laboratory suspended coring operations until after well R-20 installation. Dynatec Drilling Company, Inc. (Dynatec), completed the coring between October 16 and October 19, 2002, using a Foremost universal drill rig (UDR)-1000 equipped with a wireline core retrieval system and a 5-ft-long core barrel to collect 2.5-in.-diameter core samples. Coring was terminated at 436 ft bgs, 44 ft into the Cerros del Rio basalt. Thirteen core samples were collected from the vadose zone during drilling from 9.5 to 434.0 ft bgs.

The R-32 core hole was drilled by Dynatec using a UDR-1000 equipped with a wireline core-retrieval system and a 5-ft long core barrel that was used to collect 2.5-in.-diameter core samples. To stabilize alluvial sediments, Dynatec installed a 5-in.-diameter steel-surface casing from the surface to 16 ft bgs. Coring proceeded to 66 ft bgs with repeated caving of the borehole wall and persistently poor core recovery. The borehole instability resulted in the inability to seal off alluvial groundwater at 22 ft bgs from deeper parts of the core hole. Thus, the Laboratory decided to plug and abandon the first borehole on July 14, 2002. Dynatec relocated the UDR-1000 to a new site 10 ft to the east and cored from the surface to 50.5 ft bgs where a 6.125-in. temporary surface casing was landed in the Tshirege Member of the Bandelier Tuff at 59.1 ft bgs on July 15, 2002. Coring then resumed through Otowi Member ash flows of the Bandelier Tuff, through the underlying Guaje Pumice Bed, and 32 ft into Cerros del Rio basalt to a TD of 318 ft bgs. Thirteen core samples were collected from the vadose zone during drilling from 19.0 to 302.0 ft bgs.

Intermediate and Regional Wells

Seven regional and one perched intermediate groundwater characterization and monitoring wells were installed in Pajarito Canyon. Detailed descriptions of drilling methods for individual wells, well completion diagrams, groundwater-screening samples, borehole geophysics, and geologic logs are documented in the following reports: “Final Completion Report, Characterization Well R-17” (Kleinfelder 2006, 092493), “Final Completion Report, Characterization Well R-18” (Kleinfelder 2005, 092415), “Characterization Well R-19 Completion Report” (Broxton et al. 2001, 071254), “Characterization Well R-20 Completion Report” (LANL 2003, 079600), “Characterization Well R-22 Completion Report” (Ball et al. 2002, 071471), “Characterization Well R-23 Completion Report” (LANL 2003, 079601), “Characterization Well R-32 Completion Report” (LANL 2003, 079602), and “Final Completion Report, Intermediate Well R-23i” (Kleinfelder 2006, 092495).

Analytical results for periodic monitoring of water samples collected from these wells are presented in Appendix C of this report. A discussion of contaminants in regional and perched intermediate groundwater is presented in Section 7.2.2.

Field methods for the collection of water samples followed the procedures listed in Appendix C, Tables C-2 and C-3, of the 2008 IFGMP (101897). Field procedures follow guidelines from USGS water-sample collection methods and industrial standards common to environmental sample collection and field measurements. QC samples include laboratory blanks, spikes, and replicates.

For chemical analysis of water samples, the Laboratory uses commonly accepted analytical methods that are called for under federal regulations (such as the CWA) and that are approved by EPA. Analytical methods and method detection limits are provided in Appendix C, Table C.4, of the IFGMP (LANL 2008, 101897).

Surface Geophysics

A surface-based direct-current resistivity survey was conducted in Pajarito Canyon in 2005 to identify regions of higher conductivity beneath the canyon floor that may be related to perched alluvial groundwater and to zones of infiltration in subcropping bedrock units. The surveys were optimized to characterize variations in electrical conductivity in the upper 250 ft of the vadose zone. Details of the methodology and results for the resistivity surveys are provided in the report, “DC Resistivity Profiling in DP, Los Alamos, Pajarito, Pueblo and Sandia Canyons, Los Alamos National Laboratory, Los Alamos, New Mexico” (Geophex 2006, 094047). Locations of the resistivity survey lines and discussion of results are presented in Appendix N.

3.0 BIOTA INVESTIGATIONS

This appendix contains supplemental information on biota investigations conducted to support the evaluation of potential adverse ecological impacts presented in Section 8.1, as part of implementation of the Pajarito Canyon Biota Investigation Work Plan (LANL 2006, 093553). Table B-3.0-1 lists each sediment sample submitted for laboratory analyses, including reach, location ID, geomorphic unit, depth, date collected, and type of biota test. Table B-3.0-2 presents a crosswalk between sample IDs for earthworm samples submitted for laboratory analyses and the original sediment sample ID. Table B-3.0-3 lists egg, nestling, and insect samples from nest boxes that were submitted for laboratory analysis, including location ID, the reach or general sample location, and the nest box number (or numbers for samples that were composited from multiple boxes). Sample locations are presented in Figure 8.1-1.

B-4.0 REFERENCES

The following list includes all documents cited in this appendix. Parenthetical information following each reference provides the author(s), publication date, and ER ID number. This information is also included in text citations. ER ID numbers are assigned by the Environmental Programs Directorate's Records Processing Facility (RPF) and are used to locate the document at the RPF and, where applicable, in the master reference set.

Copies of the master reference set are maintained at the New Mexico Environment Department Hazardous Waste Bureau; the U.S. Department of Energy–Los Alamos Site Office; EPA, Region 6; and the Directorate. The set was developed to ensure that the administrative authority has all material needed to review this document, and it is updated with every document submitted to the administrative authority. Documents previously submitted to the administrative authority are not included.

Ball, T., M. Everett, P. Longmire, D. Vaniman, W. Stone, D. Larssen, K. Greene, N. Clayton, and S. McLin, February 2002. "Characterization Well R-22 Completion Report," Los Alamos National Laboratory report LA-13893-MS, Los Alamos, New Mexico. (Ball et al. 2002, 071471)

Broxton, D., D. Vaniman, W. Stone, S. McLin, J. Marin, R. Koch, R. Warren, P. Longmire, D. Rogers, and N. Tapia, May 2001. "Characterization Well R-19 Completion Report," Los Alamos National Laboratory report LA-13823-MS, Los Alamos, New Mexico. (Broxton et al. 2001, 071254)

Geophex, January 2006. "DC Resistivity Profiling in DP, Los Alamos, Pajarito, Pueblo and Sandia Canyons, Los Alamos National Laboratory, Los Alamos, NM," report prepared for Los Alamos National Laboratory, Los Alamos, New Mexico. (Geophex 2006, 094047)

Gilbert, R.O., 1987. *Statistical Methods for Environmental Pollution Monitoring*, Van Nostrand Reinhold, New York, New York. (Gilbert 1987, 056179)

Janitzky, P., 1986. "Particle-Size Analysis," in *Field and Laboratory Procedures Used in a Soil Chronosequence Study*, U.S. Geological Survey Bulletin 1648, Washington, D.C., pp. 11-17. (Janitzky 1986, 057674)

Kleinfelder, April 2005. "Final Completion Report, Characterization Well R-18," report prepared for Los Alamos National Laboratory, Project No. 37151, Albuquerque, New Mexico. (Kleinfelder 2005, 092415)

Kleinfelder, May 2006. "Final Completion Report, Characterization Well R-17," report prepared for Los Alamos National Laboratory, Project No. 49436, Albuquerque, New Mexico. (Kleinfelder 2006, 092493)

Kleinfelder, March 2006. "Final Completion Report, Intermediate Well R-23i," report prepared for Los Alamos National Laboratory, Project No. 49436, Albuquerque, New Mexico. (Kleinfelder 2006, 092495)

LANL (Los Alamos National Laboratory), September 1998. "Work Plan for Pajarito Canyon," Los Alamos National Laboratory document LA-UR-98-2550, Los Alamos, New Mexico. (LANL 1998, 059577)

LANL (Los Alamos National Laboratory), June 2003. "Characterization Well R-20 Completion Report," Los Alamos National Laboratory document LA-UR-03-1839, Los Alamos, New Mexico. (LANL 2003, 079600)

- LANL (Los Alamos National Laboratory), June 2003. "Characterization Well R-23 Completion Report," Los Alamos National Laboratory document LA-UR-03-2059, Los Alamos, New Mexico. (LANL 2003, 079601)
- LANL (Los Alamos National Laboratory), June 2003. "Characterization Well R-32 Completion Report," Los Alamos National Laboratory document LA-UR-03-3984, Los Alamos, New Mexico. (LANL 2003, 079602)
- LANL (Los Alamos National Laboratory), April 2004. "Los Alamos and Pueblo Canyons Investigation Report," Los Alamos National Laboratory document LA-UR-04-2714, Los Alamos, New Mexico. (LANL 2004, 087390)
- LANL (Los Alamos National Laboratory), July 27, 2005. "Response to the Notice of Disapproval for the Work Plan for Pajarito Canyon," Los Alamos National Laboratory document LA-UR-05-5600, Los Alamos, New Mexico. (LANL 2005, 091287)
- LANL (Los Alamos National Laboratory), July 2006. "Pajarito Canyon Biota Investigation Work Plan," Los Alamos National Laboratory document LA-UR-06-4106, Los Alamos, New Mexico. (LANL 2006, 093553)
- LANL (Los Alamos National Laboratory), October 2006. "Mortandad Canyon Investigation Report," Los Alamos National Laboratory document LA-UR-06-6752, Los Alamos, New Mexico. (LANL 2006, 094161)
- LANL (Los Alamos National Laboratory), May 2007. "2007 Interim Facility-Wide Groundwater Monitoring Plan," Los Alamos National Laboratory document LA-UR-07-3271, Los Alamos, New Mexico. (LANL 2007, 096665)
- LANL (Los Alamos National Laboratory), May 2008. "2008 Interim Facility-Wide Groundwater Monitoring Plan," Los Alamos National Laboratory document LA-UR-08-3273, Los Alamos, New Mexico. (LANL 2008, 101897)
- Malmon, D.V., June 2002. "Sediment Trajectories through a Semiarid Valley," Ph.D. dissertation, University of California, Santa Barbara, California. (Malmon 2002, 076038)
- Malmon, D.V., S.L. Reneau, and T. Dunne, 2004. "Sediment Sorting and Transport by Flash Floods," *Journal of Geophysical Research*, Vol. 109, F02005, 13 pp. (Malmon et al. 2004, 093018)
- Ryti, R.T., S.L. Reneau, and D. Katzman, 2005. "Investigations of Contaminated Fluvial Sediment Deposits: Merging of Statistical and Geomorphic Approaches," *Environmental Management*, Vol. 35, No. 5, pp. 632-648. (Ryti et al. 2005, 093019)
- TerraNearPMC, March 18, 2008. "Drilling Plan for Pajarito and Rendija Canyons Alluvial Wells," Los Alamos, New Mexico. (TerraNearPMC 2008, 102316)

Table B-1.0-1
Physical Characteristics of Post-1942
Geomorphic Units in Sediment Investigation Reaches

Reach	Geomorphic Unit	Average Unit Width (m) ^a	Sediment Facies	Estimated Average Sediment Thickness (m)	Typical Median Particle Size Class (<2-mm fraction)	Notes
AEN-1	c1	1.1	Fine	0.02	Fine sand ^b	Active channel
			Coarse	0.26	Very coarse sand	
	c2	1.3	Fine	0.17	Coarse silt	Abandoned post-1942 channel
			Coarse	0.17	Coarse sand	
	f1	0.5	Fine	0.21	Coarse silt	Post-1942 floodplain
			Coarse	0.01	Coarse sand ^b	
	f2	0.5	Fine	0.09	Very fine sand	Possible post-1942 floodplain
	Total 3.4					
AES-1	c1	1.7	Fine	0.02	Fine sand ^b	Active channel
			Coarse	0.26	Very coarse sand	
	c1br	0.1	n/a ^c	0	n/a	Active channel on bedrock
	c2	1.3	Fine	0.41	Coarse silt	Abandoned post-1942 channel
			Coarse	0.15	Coarse sand	
	f1	0.6	Fine	0.40	Coarse silt	Post-1942 floodplain
	Total 4.2					
AW-1	c1	0.5	Fine	0.09	Fine silt	Active channel
			Coarse	0.09	Coarse sand	
	c1br	0.1	n/a	0	n/a	Active channel on bedrock
	c1f	0.2	Fine	0.09	Fine Sand	Active fan along channel
			Coarse	0.24	Medium sand	
	c1w	0.6	Fine	0.23	Fine silt	Former wetland along active channel above constructed berm
			Coarse	0.03	Medium sand ^b	
	c2	2.8	Fine	0.28	Coarse silt	Abandoned post-1942 channel
			Coarse	0.08	Coarse sand	
	f1	0.1	Fine	0.03	Coarse silt ^b	Post-1942 floodplain
Total 4.2						

Table B-1.0-1 (continued)

Reach	Geomorphic Unit	Average Unit Width (m) ^a	Sediment Facies	Estimated Average Sediment Thickness (m)	Typical Median Particle Size Class (<2-mm fraction)	Notes
PA-0	c1	2.7	Fine	0.02	Fine sand ^b	Active channel; dominated by post-fire sediment
			Coarse	0.21	Coarse sand	
	c2	7.5	Fine	0.13	Very fine sand	Abandoned post-1942 channel; dominated by post-fire sediment; includes large mixed channel-floodplain areas
			Coarse	0.31	Medium sand	
	f1	3.5	Fine	0.18	Fine sand	Post-1942 floodplain; overlain by post-fire sediment
			Coarse	0.03	Medium sand ^b	
	Total		13.7			
PA-1E	c1	1.7	Coarse	0.5	Very coarse sand	
	c1br	0.05	n/a	0	n/a	Active channel on bedrock
	c2	3.9	Fine	0.42	Very fine sand	Abandoned post-1942 channel; common post-fire sediment
			Coarse	0.33	Coarse sand	
	f1	1.5	Fine	0.26	Very fine sand	Post-1942 floodplain
			Coarse	0.03	Coarse sand ^b	
	f2	0.5	Fine	0.16	Very fine sand ^b	Possible post-1942 floodplain
Total		7.4				
PA-1W	c1	1.5	Fine	0.05	Fine sand ^b	Active channel; dominated by post-fire sediment
			Coarse	0.5	Coarse sand	
	c2	1.6	Fine	0.22	Very fine sand	Abandoned post-1942 channel; common post-fire sediment
			Coarse	0.17	Medium sand	
	f1	2.3	Fine	0.14	Coarse silt	Post-1942 floodplain
			Coarse	0.02	Medium sand ^b	
Total		5.3				
PA-2E	c1	2.7	— ^d	—	—	Active channel above FRS; post-fire sediment
	c2	9.7	—	—	—	Abandoned post-2000 channel; post-fire sediment
	f1	0.4	—	—	—	Post-1942 floodplain; dominated by post-fire sediment
	f1a	0.3	—	—	—	Slackwater deposition in FRS impoundment

Table B-1.0-1 (continued)

Reach	Geomorphic Unit	Average Unit Width (m) ^a	Sediment Facies	Estimated Average Sediment Thickness (m)	Typical Median Particle Size Class (<2-mm fraction)	Notes	
	Total	13.1					
PA-2W	c1	1.4	Fine	0.05	Fine sand ^b	Active channel; dominated by post-fire sediment	
			Coarse	0.5	Very coarse sand		
	c2	4.9	Fine	0.22	Coarse silt	Abandoned post-1942 channel; common post-fire sediment	
			Coarse	0.17	Coarse sand		
	f1	5.5	Fine	0.14	Coarse silt	Post-1942 floodplain	
			Coarse	0.02	Medium sand ^b		
	f2	6.6	Fine	0.03	Coarse silt		
		Total	15.2				
	PA-3E	c1	1.7	Coarse	0.19	Coarse sand	Active channel
		c2	5.5	Fine	0.33	Coarse silt	Abandoned post-1942 channel
Coarse				0.08	Coarse sand		
c2f		0.5	Fine	0.04	Coarse silt ^b	Fan at breach in constructed berm extending from c2 unit over f1w	
			Coarse	0.2	Coarse sand ^b		
f1		1.6	Fine	0.23	Coarse silt	Post-1942 floodplain	
f1w		14.5	Fine	0.18	Coarse silt	Wetland behind berm; dominated by post-fire sediment	
f2		3.8	Fine	0.22	Coarse silt	Possible post-1942 floodplain	
	Total	25.5					
PA-4	c1	1.2	Fine	0.07	Coarse silt ^b	Active channel; common post-fire sediment	
			Coarse	0.02	Coarse sand+F165		
	c1 pool	0.8	Fine	0.22	Fine silt	Pools along active channel; common post-fire sediment	
	c1 willow	0.4	Fine	0.20	Coarse silt ^b	Willows along active channel	
			Coarse	0.12	Coarse sand		
	c1w	13.3	Fine	0.29	Coarse silt	Active wetland in borrow pit	
			Coarse	0.04	Coarse sand ^b		
	c2	1.3	Fine	0.13	Very fine sand	Abandoned post-1942 channel	
			Coarse	0.06	Coarse sand		
		Total	16.9				

Table B-1.0-1 (continued)

Reach	Geomorphic Unit	Average Unit Width (m) ^a	Sediment Facies	Estimated Average Sediment Thickness (m)	Typical Median Particle Size Class (<2-mm fraction)	Notes
PA-4E	c1	2.3	—	—	—	Active channel
	c2	1.7	—	—	—	Abandoned post-1942 channel
	f1	23.3	—	—	—	Post-1942 floodplain
	f2	0.5	—	—	—	Possible post-1942 floodplain
	Total	27.8				
PA-5W	c1	2.9	Fine	0.02	Very fine sand ^b	Active channel
			Coarse	0.04	Very coarse sand	
	c1b	0.4	Fine	0.09	Fine silt	Area of fine-grained sediment deposition along active channel
	c2	0.1	Fine	0.02	Fine sand ^b	Low abandoned post-1942 channel
			Coarse	0.14	Coarse sand	
	c3	1.3	Fine	0.11	Fine sand	High abandoned post-1942 channel
			Coarse	0.19	Coarse sand	
	f1	2.1	Fine	0.13	Very fine sand	Post-1942 floodplain
	f2	0.1	Fine	0.02	Very fine sand ^b	Possible post-1942 floodplain
	Total	7.0				
PAS-1E	c1	1.2	Fine	0.06	Very fine sand ^b	Active channel
			Coarse	0.27	Coarse sand	
	c1br	0.1	n/a	0	n/a	Active channel on bedrock
	c2	2.9	Fine	0.42	Coarse silt	Abandoned post-1942 channel
			Coarse	0.2	Coarse sand	
	f1	0.4	Fine	0.14	Coarse silt	Post-1942 floodplain
	f2	0.02	Fine	0.02	Coarse silt ^b	Possible post-1942 floodplain
Total	4.6					

Table B-1.0-1 (continued)

Reach	Geomorphic Unit	Average Unit Width (m) ^a	Sediment Facies	Estimated Average Sediment Thickness (m)	Typical Median Particle Size Class (<2-mm fraction)	Notes
PAS-2W	c1	2.0	Fine	0.04	Very fine sand ^b	Active channel
			Coarse	0.12	Very coarse sand	
	c1b	0.05	Fine	0.18	Coarse silt ^b	Area of fine-grained sediment deposition along active channel
			Coarse	0.3	Very coarse sand ^b	
	c1br	0.3	n/a	0	n/a	Active channel on bedrock
	c2	1.5	Fine	0.21	Coarse silt	Abandoned post-1942 channel
			Coarse	0.3	Coarse sand	
	f1	2.5	Fine	0.25	Coarse silt	Post-1942 floodplain
			Coarse	0.01	Coarse sand ^b	
	Total		6.3			
TH-1C	c1	0.3	Fine	0.11	Very fine sand ^b	Active channel
			Coarse	0.19	Coarse sand	
	c1br	0.03	n/a	0	n/a	Active channel on bedrock
	c2	3.9	Fine	0.37	Coarse silt	Low abandoned post-1942 channel
			Coarse	0.27	Coarse sand	
	c2a	0.1	Fine	0.05	Coarse silt ^b	High abandoned post-1942 channel
			Coarse	0.13	Coarse sand ^b	
	f1	0.2	Fine	0.17	Coarse silt ^b	Post-1942 floodplain
			Coarse	0.01	Medium sand ^b	
	Total		4.5			
TH-1E	c1	0.1	Fine	0.33	Coarse silt ^b	Active channel
			Coarse	0.13	Coarse sand	
	c1br	0.02	n/a	0	n/a	Active channel on bedrock
	c2	5.1	Fine	0.44	Coarse silt	Abandoned post-1942 channel
			Coarse	0.27	Coarse sand	
	f1	0.7	Fine	0.17	Coarse silt	Post-1942 floodplain
			Coarse	0.01	Medium sand ^b	
	Total		4.2			

Table B-1.0-1 (continued)

Reach	Geomorphic Unit	Average Unit Width (m) ^a	Sediment Facies	Estimated Average Sediment Thickness (m)	Typical Median Particle Size Class (<2-mm fraction)	Notes
TH-3	c1	1.2	—	—	—	Active channel
	c2	2.4	—	—	—	Low abandoned post-1942 channel
	c2a	2.3	—	—	—	Intermediate abandoned post-1942 channel
	c3	5.4	—	—	—	High abandoned post-1942 channel
	f1	1.9	—	—	—	Post-1942 floodplain
	f2	2.4	—	—	—	Possible post-1942 floodplain
	Total		15.6			
THM-1	c1	1.1	Fine	0.01	Fine sand ^b	Active channel
			Coarse	0.25	Coarse sand	
	c1br	0.04	n/a	0	n/a	Active channel on bedrock
	c2	1.7	Fine	0.27	Very fine sand	Abandoned post-1942 channel
			Coarse	0.37	Coarse sand	
	f1	0.6	Fine	0.41	Very fine sand	Post-1942 floodplain
			Coarse	0.03	Medium sand ^b	
Total		3.4				

Table B-1.0-1 (continued)

Reach	Geomorphic Unit	Average Unit Width (m) ^a	Sediment Facies	Estimated Average Sediment Thickness (m)	Typical Median Particle Size Class (<2-mm fraction)	Notes	
THS-1E	c1	1.2	Fine	0.14	Very fine sand ^b	Active channel	
			Coarse	0.54	Very coarse sand		
	c1b	0.7	Fine	0.26	Very fine sand	Area of fine-grained sediment deposition along active channel	
			Coarse	0.47	Coarse sand		
	c2	3.6	Fine	0.41	Coarse silt	Abandoned post-1942 channel	
			Coarse	0.28	Coarse sand		
	f1	0.1	Fine	0.23	Coarse silt	Post-1942 floodplain	
			Coarse	0.01	Medium sand ^b		
	Total		5.6				
	THS-1W	c1	0.8	Fine	0.02	Very fine sand ^b	Active channel
Coarse				0.26	Coarse sand		
c1br		0.1	n/a	0	n/a	Active channel on bedrock	
c2		1.8	Fine	0.23	Coarse silt	Abandoned post-1942 channel	
			Coarse	0.16	Coarse sand		
f1		1.3	Fine	0.17	Very fine sand	Post-1942 floodplain	
			Coarse	0.03	Medium sand ^b		
f2		0.2	Fine	0.05	Coarse silt ^b	Possible post-1942 floodplain	
Total		4.2					
THW-1		c1	1.3	Fine	0.12	Very fine sand ^b	Active channel
	Coarse			0.20	Coarse sand		
	c1br	0.05	n/a	0	n/a	Active channel on bedrock	
	c2	3.6	Fine	0.24	Coarse silt	Abandoned post-1942 channel	
			Coarse	0.18	Medium sand		
	f1	3.2	Fine	0.20	Coarse silt	Post-1942 floodplain	
			Coarse	0.01	Medium sand ^b		
	Total		8.1				

Table B-1.0-1 (continued)

Reach	Geomorphic Unit	Average Unit Width (m) ^a	Sediment Facies	Estimated Average Sediment Thickness (m)	Typical Median Particle Size Class (<2-mm fraction)	Notes	
TW-1E	c1	2.5	Fine	0.01	Fine sand ^b	Active channel; dominated by post-fire sediment	
			Coarse	0.35	Coarse sand		
	c1b	0.2	Fine	0.03	Very fine sand ^b	Area of fine-grained sediment deposition along active channel	
			Coarse	0.33	Coarse sand		
	c1br	0.1	n/a	0	n/a	Active channel on bedrock	
	c2	1.1	Fine	0.13	Very fine sand	Abandoned post-1942 channel	
			Coarse	0.3	Coarse sand		
	f1	0.7	Fine	0.14	Coarse silt	Post-1942 floodplain	
			Coarse	0.07	Medium sand ^b		
	Total	4.5					
TW-1W	c1	2.2	Coarse	0.22	Coarse sand	Active channel; dominated by post-fire sediment	
	c2	1.8	Fine	0.10	Very fine sand	Low abandoned post-1942 channel	
			Coarse	0.35	Coarse sand		
	c3	0.4	Fine	0.06	Very fine sand ^b	High abandoned post-1942 channel	
			Coarse	1.03	Coarse sand		
	f1	1.9	Fine	0.16	Very fine sand	Post-1942 floodplain	
			Coarse	0.06	Medium sand ^b		
	Total	6.3					
	TW-2E	c1	1.8	Coarse	0.4	Coarse sand	Active channel; dominated by post-fire sediment
		c2	2.5	Fine	0.40	Very fine sand	Low abandoned post-1942 channel
Coarse				0.42	Coarse sand		
c3		0.9	Fine	0.53	Very fine sand	High abandoned post-1942 channel	
			Coarse	0.4	Coarse sand		
f1		2.5	Fine	0.14	Coarse silt	Post-1942 floodplain	
			Coarse	0.01	Medium sand ^b		
f2		0.1	Fine	0.02	Coarse silt ^b	Possible post-1942 floodplain	
Total		7.8					

Table B-1.0-1 (continued)

Reach	Geomorphic Unit	Average Unit Width (m) ^a	Sediment Facies	Estimated Average Sediment Thickness (m)	Typical Median Particle Size Class (<2-mm fraction)	Notes	
TW-3E	c1	2.9	Fine	0.05	Very fine sand ^b	Active channel; dominated by post-fire sediment	
			Coarse	0.38	Very coarse sand		
	c2	0.6	Fine	0.20	Coarse silt	Abandoned post-1942 channel; common post-fire sediment	
			Coarse	0.32	Coarse sand		
	f1	5.3	Fine	0.50	Coarse silt	Post-1942 floodplain	
			Coarse	0.03	Medium sand ^b		
	f2	0.4	Fine	0.03	Coarse silt ^b	Possible post-1942 floodplain	
	Total	9.3					
	TW-4E	c1	7.2	—	—	—	Active channel; dominated by post-fire sediment
		c2	9.6	—	—	—	Abandoned post-1942 channel; post-fire sediment
f1		1.0	—	—	—	Post-1942 floodplain; dominated by post-fire sediment	
f1a		0.1	—	—	—	Slackwater deposition in FRS impoundment	
Total		18.0					
TW-4W	c1	2.3	Fine	0.05	Fine sand ^b	Active channel	
			Coarse	0.5	Coarse sand		
	c1b	0.1	Fine	0.05	Fine sand ^b	Area of fine-grained sediment deposition along active channel	
			Coarse	0.5	Coarse sand ^b		
	c2	2.4	Fine	0.31	Medium sand	Low abandoned post-1942 channel	
			Coarse	0.35	Coarse sand		
	c3	1.0	Fine	0.51	Very fine sand	High abandoned post-1942 channel	
			Coarse	0.43	Coarse sand ^b		
	f1	1.4	Fine	0.31	Coarse silt	Post-1942 floodplain	
			Coarse	0.05	Medium sand ^b		
f2	0.7	Fine	0.21	Coarse silt ^b	Possible post-1942 floodplain		
Total	7.4						

Table B-1.0-1 (continued)

Reach	Geomorphic Unit	Average Unit Width (m) ^a	Sediment Facies	Estimated Average Sediment Thickness (m)	Typical Median Particle Size Class (<2-mm fraction)	Notes
TWN-1E	c1	3.2	Fine	0.16	Coarse silt	Active channel
			Coarse	0.65	Coarse sand	
	c2	0.5	Fine	0.11	Coarse silt	Low abandoned post-1942 channel
			Coarse	0.3	Coarse sand	
	c3	0.4	Fine	0.26	Very fine sand	High abandoned post-1942 channel
			Coarse	0.55	Coarse sand ^b	
	f1	1.4	Fine	0.26	Coarse silt	Post-1942 floodplain
			Coarse	0.07	Medium sand ^b	
	f2	0.04	Fine	0.26	Coarse silt ^b	Possible post-1942 floodplain
			Coarse	0.07	Medium sand ^b	
Total	5.5					
TWN-1W	c1	2.0	Fine	0.10	Coarse silt	Active channel; dominated by post-fire sediment
			Coarse	0.37	Coarse sand	
	c2	2.8	Fine	0.20	Very fine sand	Low abandoned post-1942 channel
			Coarse	0.35	Coarse sand	
	c2a	0.1	Fine	0.21	Very fine sand ^b	High abandoned post-1942 channel
			Coarse	0.24	Coarse sand ^b	
	f1	0.7	Fine	0.22	Coarse silt	Post-1942 floodplain
	Total	5.6				
TWSE-1E	c1	2.5	Fine	0.05	Very fine sand ^b	Active channel
			Coarse	0.49	Coarse sand	
	c1b	0.1	Fine	0.24	Coarse silt	Area of fine-grained sediment deposition along active channel
			Coarse	0.16	Coarse sand ^b	
	c2	1.1	Fine	0.25	Coarse silt	Low abandoned post-1942 channel
			Coarse	0.3	Very coarse sand	
	c3	0.4	Fine	0.21	Very fine sand	High abandoned post-1942 channel
			Coarse	0.75	Coarse sand	
	f1	0.8	Fine	0.24	Coarse silt	Post-1942 floodplain
			Coarse	0.02	Medium sand ^b	
f2	0.4	Fine	0.06	Coarse silt ^b	Possible post-1942 floodplain	
Total	5.0					

Table B-1.0-1 (continued)

Reach	Geomorphic Unit	Average Unit Width (m) ^a	Sediment Facies	Estimated Average Sediment Thickness (m)	Typical Median Particle Size Class (<2-mm fraction)	Notes
TWSE-1W	c1	0.4	Fine	0.19	Very fine sand ^b	Active channel
			Coarse	0.10	Coarse sand	
	c1br	0.2	n/a	0	n/a	Active channel on bedrock
	c2	2.0	Fine	0.41	Coarse silt	Abandoned post-1942 channel
			Coarse	0.09	Coarse sand ^b	
	f1	3.2	Fine	0.21	Coarse silt	Post-1942 floodplain
Total		5.7				
TWSW-1E	c1	0.7	Fine	0.05	Very fine sand ^b	Active channel
			Coarse	0.19	Coarse sand	
	c1br	0.1	n/a		n/a	Active channel on bedrock
	c2	1.2	Fine	0.31	Coarse silt	Abandoned post-1942 channel
			Coarse	0.23	Coarse sand	
	f1	1.3	Fine	0.26	Coarse silt	Post-1942 floodplain
			Coarse	0.01	Medium sand ^b	
	f2	0.2	Fine	0.07	Coarse silt ^b	Possible post-1942 floodplain
Total		3.3				
TWSW-1W	c1	0.6	Fine	0.12	Very fine sand ^b	Active channel
			Coarse	0.1	Coarse sand	
	c1br	0.3	n/a	0	n/a	Active channel on bedrock
	c2	2.7	Fine	0.29	Coarse silt	Abandoned post-1942 channel
			Coarse	0.18	Coarse sand ^b	
	f1	2.2	Fine	0.17	Coarse silt	Post-1942 floodplain
			Coarse	0.01	Medium sand ^b	
	f2	0.1	Fine	0.02	Coarse silt ^b	Possible post-1942 floodplain
Total		5.7				

^a Average unit width is total area of unit in reach divided by reach length.

^b No particle size data from unit; median particle size inferred based on data from other units and field descriptions.

^c n/a = Not applicable.

^d — = No thickness measurements or particle size data from reach.

**Table B-1.0-2
Sediment Thickness Measurements from Sediment Investigation Reaches**

Reach	Stratigraphic Description Location	Location ID	Reach Distance (m)	Side of Channel	Geomorphic Unit	Fine Facies Thickness (cm)	Coarse Facies Thickness (cm)	Inferred Post-Fire Fine Facies Thickness (cm) ^a	Inferred Post-Fire Coarse Facies Thickness (cm) ^a
AEN-1	AEN1-s1	— ^b	3	S	c2	9	18	0	0
AEN-1	AEN1-s2	—	15	N	c2	28	8	0	0
AEN-1	AEN1-s3	PA-24865	21	S	c2	23	38	0	0
AEN-1	AEN1-s4	—	24	S	f2? (Qt?)	4	0	0	0
AEN-1	AEN1-s5	—	25	S	f2? (Qt?)	10	0	0	0
AEN-1	AEN1-s6	—	28	S	f2? (Qt?)	4	0	0	0
AEN-1	AEN1-s7	—	33	S	c2	7	36	0	0
AEN-1	AEN1-s8	PA-24867	39	N	f2? (f1?)	30	0	0	0
AEN-1	AEN1-s9	—	45	N	c2	14	34	0	0
AEN-1	AEN1-s10	PA-24868	53	S	c2	25	0	0	0
AEN-1	AEN1-s11	PA-24869	64	N	c2	25	0	0	0
AEN-1	AEN1-s12	—	75	S	c2	6	20	0	0
AEN-1	AEN1-s13	—	88	N	c2	12	23	0	0
AEN-1	AEN1-s14	—	90	N	f1	43	0	0	0
AEN-1	AEN1-s15	—	101	S	c2	9	30	0	0
AEN-1	AEN1-s16	PA-24871	111	S	f1	21	0	0	0
AEN-1	AEN1-s17	—	113	N	f1	10	3	0	0
AEN-1	AEN1-s18	—	122	N	f1	17	5	0	0
AEN-1	AEN1-s19	PA-24872	127	N	f1	19	0	0	0
AEN-1	AEN1-s20	PA-24873	147	S	f1	16	0	0	0
AEN-1	AEN1-s21	—	149	S	c2	16	10	0	0
AEN-1	AEN1-s22	—	152	N	c2	18	4	0	0

Table B-1.0-2 (continued)

Reach	Stratigraphic Description Location	Location ID	Reach Distance (m)	Side of Channel	Geomorphic Unit	Fine Facies Thickness (cm)	Coarse Facies Thickness (cm)	Inferred Post-Fire Fine Facies Thickness (cm) ^a	Inferred Post-Fire Coarse Facies Thickness (cm) ^a
AEN-1	AEN1-s23	—	155	N	f2	2	0	0	0
AEN-1	AEN1-s24	—	166	S	f2	5	0	0	0
AEN-1	AEN1-s25	—	170	S	c2	9	0	0	0
AEN-1	AEN1-s26	PA-24874	179	N	c2	14	17	0	0
AEN-1	AEN1-s27	—	190	S	c2	33	13	0	0
AES-1	AES1-s1	—	186	—	c1	10	19	0	0
AES-1	AES1-s2	—	184	E	c2	14	40	0	0
AES-1	AES1-s4	—	164	W	c2	69	11	0	0
AES-1	AES1-s3	PA-24864	165	E	c2	36	8	0	0
AES-1	AES1-s5	—	159	-	c1	0	12	0	0
AES-1	AES1-s6	—	151	E	c2	36	0	0	0
AES-1	AES1-s7	—	140	—	c1	0	0	0	0
AES-1	AES1-s8	PA-24863	133	W	c2	42	9	0	0
AES-1	AES1-s9	—	126	E	c2	39	22	0	0
AES-1	AES1-s10	PA-24862	116	—	c1	0	36	0	0
AES-1	AES1-s11	—	111	E	f1? (c2?)	34	0	0	0
AES-1	AES1-s12	—	98	W	f1	27	0	0	0
AES-1	AES1-s13	—	92	E	c2	17	0	0	0
AES-1	AES1-s14	—	90	—	c1	5	24	0	0
AES-1	AES1-s15	PA-24860	71	N	f1	77	0	0	0
AES-1	AES1-s16	—	68	—	c1	0	30	0	0
AES-1	AES1-s17	—	65	S	f1	39	0	0	0
AES-1	AES1-s18	—	65	N	f1	31	0	0	0
AES-1	AES1-s19	—	59	S	f1	38	0	0	0

Table B-1.0-2 (continued)

Reach	Stratigraphic Description Location	Location ID	Reach Distance (m)	Side of Channel	Geomorphic Unit	Fine Facies Thickness (cm)	Coarse Facies Thickness (cm)	Inferred Post-Fire Fine Facies Thickness (cm) ^a	Inferred Post-Fire Coarse Facies Thickness (cm) ^a
AES-1	AES1-s20	—	51	S	f1	6	0	0	0
AES-1	AES1-s21	—	50	—	c1	0	19	0	0
AES-1	AES1-s22	PA-24859	33	N	f1	67	0	0	0
AES-1	AES1-s23	PA-24857	32	S	c2	26	37	0	0
AES-1	AES1-s24	—	26	N	c2	67	10	0	0
AES-1	AES1-s25	—	24	N	c2	27	42	0	0
AES-1	AES1-s26	—	22	—	c1	0	65	0	0
AES-1	AES1-s27	—	11	S	c2	43	0	0	0
AES-1	AES1-s28	PA-24855	7	N	c2	78	0	0	0
AW-1	AW1-s1	—	195	middle	c2	20	0	10	0
AW-1	AW1-s2	—	188	—	c1	9	0	2	0
AW-1	AW1-s3	PA-26417	185	S	c2	9	43	9	0
AW-1	AW1-s4	PA-26416	175	S	c2	33	0	11	0
AW-1	AW1-s5	—	173	—	c1	23	10	7	10
AW-1	AW1-s6	PA-601024	167	—	c2	36	4	5	0
AW-1	AW1-s7	—	157	N	c2	32	31	9	0
AW-1	AW1-s8	—	155	—	c1	9	20	6	0
AW-1	AW1-s9	PA-26415	155	S	c2	29	0	0	0
AW-1	AW1-s10	—	139	S	c2	42	8	0	0
AW-1	AW1-s11	PA-26414	138	—	c1	0	15	0	0
AW-1	AW1-s12	PA-601022	128	N	c2	13	39	0	0
AW-1	AW1-s13	PA-601021	122	—	c1	14	16	0	0
AW-1	AW1-s14	PA-26413	116	—	c2	58	3	0	0
AW-1	AW1-s15	PA-26412	95	N	c2	37	0	0	0

Table B-1.0-2 (continued)

Reach	Stratigraphic Description Location	Location ID	Reach Distance (m)	Side of Channel	Geomorphic Unit	Fine Facies Thickness (cm)	Coarse Facies Thickness (cm)	Inferred Post-Fire Fine Facies Thickness (cm) ^a	Inferred Post-Fire Coarse Facies Thickness (cm) ^a
AW-1	AW1-s16	PA-601019	89	S	c2	34	0	0	0
AW-1	AW1-s17	—	85	—	c1	7	6	0	0
AW-1	AW1-s18	—	63	—	c1	12	0	0	0
AW-1	AW1-s19	—	40	—	c2	25	6	0	0
AW-1	AW1-s20	PA-601018	50	—	c2	13	0	0	0
AW-1	AW1-s21	—	25	—	c1	0	6	0	4
AW-1	AW1-s22	PA-601017	12	—	c2	22	0	0	0
AW-1	AW1-s23	PA-601016	4	N fk	c2	13	0	0	0
AW-1	AW1-s24	—	-23	—	c1w	18	4	0	0
AW-1	AW1-s25	—	-14	—	c1w	24	0	0	0
AW-1	AW1-s26	PA-26408	-15	W	c1w	27	6	0	0
AW-1	AW1-s27	PA-26410	-11	N fk	c2	31	0	0	0
AW-1	AW1-s28	—	-14	N fk	f1	3	0	0	0
AW-1	AW1-s29	—	-27	—	c1f	7	28	0	0
AW-1	AW1-s30	PA-601015	-26	—	c1f	10	20	0	0
PA-0	PA0-s1	—	197	N	f1	16	0	16	0
PA-0	PA0-s2	—	199	S	c2+f1	0	125	0	125
PA-0	PA0-s3	—	194	S	c2	0	29	0	29
PA-0	PA0-s4	—	188	—	c1	12	14	0	14
PA-0	PA0-s5	PA-26506	187	S	c2+f1	0	38	0	38
PA-0	PA0-s6	—	180	N	c2	30	13	30	13
PA-0	PA0-s7	PA-26505	164	N	c2+f1	12	73	12	73
PA-0	PA0-s8	—	163	—	c1	0	30	0	30
PA-0	PA0-s9	PA-26504	161	S	f1	39	31	34	31

Table B-1.0-2 (continued)

Reach	Stratigraphic Description Location	Location ID	Reach Distance (m)	Side of Channel	Geomorphic Unit	Fine Facies Thickness (cm)	Coarse Facies Thickness (cm)	Inferred Post-Fire Fine Facies Thickness (cm) ^a	Inferred Post-Fire Coarse Facies Thickness (cm) ^a
PA-0	PA0-s10	—	160	S	c2	0	45	0	45
PA-0	PA0-s11	PA-26503	150	S	f1	34	0	24	0
PA-0	PA0-s12	—	143	N	c2	0	58	0	58
PA-0	PA0-s13	—	138	—	c1	0	11	0	11
PA-0	PA0-s14	PA-26502	140	S	c2	37	2	37	2
PA-0	PA0-s15	—	129	N	c2	38	0	14	0
PA-0	PA0-s16	—	125	N	c2+f1	7	13	7	13
PA-0	PA0-s17	PA-26501	118	N	c2+f1	41	13	14	13
PA-0	PA0-s18	—	119	N	c2	0	34	0	34
PA-0	PA0-s19	—	113	—	c1	0	4	0	4
PA-0	PA0-s20	—	103	N	c2	19	0	5	0
PA-0	PA0-s21	PA-26500	92	N	f1	12	0	12	0
PA-0	PA0-s22	PA-26498	87	N	c2	4	42	4	42
PA-0	PA0-s23	PA-26499	88	—	c1	0	30	0	30
PA-0	PA0-s24	—	88	N	c2+f1	20	30	0	30
PA-0	PA0-s25	—	88	S	f1	5	0	5	0
PA-0	PA0-s26	—	74	mid	c2+f1	18	2	10	2
PA-0	PA0-s27	—	72	N	f1	2	0	2	0
PA-0	PA0-s28	—	63	—	c1	0	35	0	35
PA-0	PA0-s29	—	53	N	f1	3	0	3	0
PA-0	PA0-s30	—	0	S	f1	8	0	0	0
PA-0	PA0-s30	—	57	mid	c2+f1	24	6	13	6
PA-0	PA0-s31	—	53	mid	c2	9	16	0	16
PA-0	PA0-s32	PA-26497	40	N	c2+f1	22	37	5	32

Table B-1.0-2 (continued)

Reach	Stratigraphic Description Location	Location ID	Reach Distance (m)	Side of Channel	Geomorphic Unit	Fine Facies Thickness (cm)	Coarse Facies Thickness (cm)	Inferred Post-Fire Fine Facies Thickness (cm) ^a	Inferred Post-Fire Coarse Facies Thickness (cm) ^a
PA-0	PA0-s33	—	38	—	c1	0	24	0	24
PA-0	PA0-s34	—	35	S	c2	0	50	0	50
PA-0	PA0-s35	—	33	S	f1	13	0	5	0
PA-0	PA0-s36	—	21	N	f1	8	0	3	0
PA-0	PA0-s37	—	12	—	c1	0	21	0	21
PA-0	PA0-s38	—	12	N	c2+f1	0	3	0	3
PA-0	PA0-s39	—	1	mid	f1	54	0	5	0
PA-1E	PA1E-s1	—	6	N	f1? (c3?)	18	8	8	8
PA-1E	PA1E-s2	18-10085	7	N	c2	41	15	14	0
PA-1E	PA1E-s3	—	15	S	c2	49	11	14	0
PA-1E	PA1E-s4	—	25	S	f2? (Qt?)	13	0	0	0
PA-1E	PA1E-s5	—	26	S	f1? (c3?)	28	0	2	0
PA-1E	PA1E-s6	18-10086	26	N	f1? (c3?)	36	0	12	0
PA-1E	PA1E-s7	PA-26562	28	S	c2	52	34	14	0
PA-1E	PA1E-s8	18-10087	37	N	c2	45	14	45	5
PA-1E	PA1E-s9	—	43	S	c2	37	16	13	0
PA-1E	PA1E-s10	—	47	N	f2? (Qt?)	18	0	0	0
PA-1E	PA1E-s11	—	58	N	c2	43	2	43	0
PA-1E	PA1E-s12	18-10088	58	N	f1	20	8	7	8
PA-1E	PA1E-s13	—	70	N	c2	42	2	17	0
PA-1E	PA1E-s14	—	91	S	c2	49	5	5	5
PA-1E	PA1E-s15	—	92	N	c2	28	18	12	0
PA-1E	PA1E-s17	—	103	S	c2? (f1?)	32	13	25	13
PA-1E	PA1E-s18	PA-26564	113	S	c2? (f1?)	26	18	16	18

Table B-1.0-2 (continued)

Reach	Stratigraphic Description Location	Location ID	Reach Distance (m)	Side of Channel	Geomorphic Unit	Fine Facies Thickness (cm)	Coarse Facies Thickness (cm)	Inferred Post-Fire Fine Facies Thickness (cm) ^a	Inferred Post-Fire Coarse Facies Thickness (cm) ^a
PA-1E	PA1E-s19	—	120	S	c2	54	25	32	8
PA-1E	PA1E-s20	—	124	S	f1	24	0	12	0
PA-1E	PA1E-s21	—	131	S	f1? (c3?)	27	0	7	0
PA-1E	PA1E-s22	—	139	S	c2	47	5	10	3
PA-1E	PA1E-s23	—	158	S	c2	32	2	4	0
PA-1E	PA1E-s24	—	167	S	c2	39	13	21	0
PA-1E	PA1E-s25	—	170	N	c2	33	17	7	0
PA-1E	PA1E-s26	—	184	S	c2	60	2	29	0
PA-1E	PA1E-s27	PA-26567	196	N	c2	48	2	12	0
PA-1W	PA1W-s1	—	194	SW	f1? (c3?)	13	0	13	0
PA-1W	PA1W-s2	—	194	—	c1	0	35	0	35
PA-1W	PA1W-s3	PA-26519	189	SW	c2	42	11	42	0
PA-1W	PA1W-s4	—	183	SW	f1? (c3?)	13	0	0	0
PA-1W	PA1W-s5	—	171	NE	c2	45	0	20	0
PA-1W	PA1W-s6	—	165	SW	c2	10	24	10	24
PA-1W	PA1W-s7	—	157	NE	c2	24	8	24	8
PA-1W	PA1W-s8	PA-26518	156	SW	f1? (c3?)	34	0	9	0
PA-1W	PA1W-s9	—	154	NE	f1? (c3?)	33	4	9	0
PA-1W	PA1W-s10	—	146	NE	c2	22	17	22	17
PA-1W	PA1W-s11	—	143	SW	c2	13	21	13	21
PA-1W	PA1W-s13	—	125	SW	c2	41	20	12	20
PA-1W	PA1W-s14	—	113	SW	f1	31	0	6	0
PA-1W	PA1W-s15	PA-26516	104	SW	f1	28	0	28	0
PA-1W	PA1W-s16	—	92	SW	f1	15	0	1	0

Table B-1.0-2 (continued)

Reach	Stratigraphic Description Location	Location ID	Reach Distance (m)	Side of Channel	Geomorphic Unit	Fine Facies Thickness (cm)	Coarse Facies Thickness (cm)	Inferred Post-Fire Fine Facies Thickness (cm) ^a	Inferred Post-Fire Coarse Facies Thickness (cm) ^a
PA-1W	PA1W-s17	—	91	NE	f1	11	0	0	0
PA-1W	PA1W-s18	—	76	SW	f1? (c3?)	29	0	24	0
PA-1W	PA1W-s19	—	67	NE	f1? (c3?)	32	0	6	0
PA-1W	PA1W-s20	—	61	SW	f1? (c3?)	50	0	21	0
PA-1W	PA1W-s21	—	58	NE	c2	28	10	15	4
PA-1W	PA1W-s22	PA-26515	56	SW	f1? (c3?)	33	0	4	0
PA-1W	PA1W-s23	PA-26513	47	SW	c2	25	40	0	40
PA-1W	PA1W-s24	—	46	SW	f1? (c3?)	18	0	18	0
PA-1W	PA1W-s25	PA-26512	33	NE	c2	39	9	0	7
PA-1W	PA1W-s26	—	32	SW	c2	26	7	26	5
PA-1W	PA1W-s27	—	18	NE	f1? (c3?)	35	0	3	0
PA-1W	PA1W-s28	—	9	NE	f1? (c3?)	11	0	0	0
PA-1W	PA1W-s29	—	4	SW	f1	20	0	9	0
PA-2W	PA2W-s1	—	6	N	c2	32	8	23	8
PA-2W	PA2W-s2	—	16	S	c2	28	16	15	16
PA-2W	PA2W-s3	—	4	S	f2	5	0	0	0
PA-2W	PA2W-s4	—	14	N	f1	4	0	0	0
PA-2W	PA2W-s5	—	18	N	f1	5	0	0	0
PA-2W	PA2W-s6	—	21	S	f1	17	4	0	0
PA-2W	PA2W-s7	—	28	N	c2	18	12	18	0
PA-2W	PA2W-s8	PA-24986	33	S	c2	48	20	27	0
PA-2W	PA2W-s9	—	37	N	f1	24	0	8	0
PA-2W	PA2W-s10	—	42	S	f1	18	0	6	0
PA-2W	PA2W-s11	PA-24987	38	S	f2	6	0	0	0

Table B-1.0-2 (continued)

Reach	Stratigraphic Description Location	Location ID	Reach Distance (m)	Side of Channel	Geomorphic Unit	Fine Facies Thickness (cm)	Coarse Facies Thickness (cm)	Inferred Post-Fire Fine Facies Thickness (cm) ^a	Inferred Post-Fire Coarse Facies Thickness (cm) ^a
PA-2W	PA2W-s12	—	54	S	f1	0	17	0	17
PA-2W	PA2W-s13	—	55	N	c2	11	39	0	10
PA-2W	PA2W-s14	—	64	S	f1	9	0	9	0
PA-2W	PA2W-s15	—	62	S	f2	3	0	0	0
PA-2W	PA2W-s16	—	70	S	f2	1	0	1	0
PA-2W	PA2W-s17	—	72	S	c2	11	15	7	4
PA-2W	PA2W-s18	PA-24988	84	N	f1	14	0	14	0
PA-2W	PA2W-s19	—	77	S	f1	11	0	11	0
PA-2W	PA2W-s20	—	86	S	f2	6	0	0	0
PA-2W	PA2W-s21	—	94	S	c2	1	50	1	24
PA-2W	PA2W-s22	PA-24989	90	N	c2	5	50	0	7
PA-2W	PA2W-s23	—	107	N	f1	5	0	5	0
PA-2W	PA2W-s24	—	117	N	f2	0	0	0	0
PA-2W	PA2W-s25	—	120	N	c2	20	9	10	0
PA-2W	PA2W-s26	—	113	S	c2	13	50	6	0
PA-2W	PA2W-s27	—	118	S	f2	5	0	0	0
PA-2W	PA2W-s28	PA-24990	129	S	f1	31	0	11	0
PA-2W	PA2W-s29	—	139	S	c2	24	0	24	0
PA-2W	PA2W-s30	—	140	S	f1	12	0	0	0
PA-2W	PA2W-s31	—	146	S	c2	29	0	9	0
PA-2W	PA2W-s32	—	146	N	c2	29	9	0	0
PA-2W	PA2W-s33	—	160	S	c2	31	12	0	0
PA-2W	PA2W-s34	—	172	S	f2	0	0	0	0
PA-2W	PA2W-s35	—	174	N	c2	6	0	0	0

Table B-1.0-2 (continued)

Reach	Stratigraphic Description Location	Location ID	Reach Distance (m)	Side of Channel	Geomorphic Unit	Fine Facies Thickness (cm)	Coarse Facies Thickness (cm)	Inferred Post-Fire Fine Facies Thickness (cm) ^a	Inferred Post-Fire Coarse Facies Thickness (cm) ^a
PA-2W	PA2W-s36	—	175	N	c2	15	18	15	0
PA-2W	PA2W-s37	PA-24991	174	N	f1	29	0	15	0
PA-2W	PA2W-s38	18-10094	183	N	c2	30	0	0	0
PA-2W	PA2W-s39	—	192	N	f1	20	10	8	0
PA-2W	PA2W-s40	PA-24992	199	N	c2	37	5	30	0
PA-3E	PA3E-s1	PA-24995	255	S	f1	21	0	4	0
PA-3E	PA3E-s2	—	257	S	c2	31	0	5	0
PA-3E	PA3E-s3	—	262	N	f2	41	0	0	0
PA-3E	PA3E-s4	—	264	—	c1	0	11	0	11
PA-3E	PA3E-s5	—	270	N	f1	26	0	17	0
PA-3E	PA3E-s6	PA-24996	276	S	c2	43	3	4	0
PA-3E	PA3E-s7	—	283	N	c2	32	19	10	0
PA-3E	PA3E-s8	—	283	S	f1	32	0	7	0
PA-3E	PA3E-s9	—	292	—	c1	0	22	0	22
PA-3E	PA3E-s10	—	292	N	f1	22	0	0	0
PA-3E	PA3E-s11	PA-24997	293	S	f2	25	0	0	0
PA-3E	PA3E-s12	PA-24998	302	N	c2	41	0	12	0
PA-3E	PA3E-s13	—	312	-	c1	0	6	0	6
PA-3E	PA3E-s14	—	313	S	c2	25	0	3	0
PA-3E	PA3E-s15	—	314	S	f2	10	0	0	0
PA-3E	PA3E-s16	—	334	S	c2	17	6	3	6
PA-3E	PA3E-s17	—	340	S	f2	8	0	0	0
PA-3E	PA3E-s18	—	341	—	c1	0	20	0	20
PA-3E	PA3E-s19	—	350	S	f2	26	0	0	0

Table B-1.0-2 (continued)

Reach	Stratigraphic Description Location	Location ID	Reach Distance (m)	Side of Channel	Geomorphic Unit	Fine Facies Thickness (cm)	Coarse Facies Thickness (cm)	Inferred Post-Fire Fine Facies Thickness (cm) ^a	Inferred Post-Fire Coarse Facies Thickness (cm) ^a
PA-3E	PA3E-s20	—	363	S	c2	43	0	6	0
PA-3E	PA3E-s21	—	365	—	c1	0	5	0	5
PA-3E	PA3E-s22	—	373	S	f2	20	0	0	0
PA-3E	PA3E-s23	PA-24999	384	S	c2	27	0	0	0
PA-3E	PA3E-s24	—	387	—	c1	0	1	0	1
PA-3E	PA3E-s25	—	407	—	c1	4	42	4	9
PA-3E	PA3E-s26	—	408	N	c2	37	4	4	0
PA-3E	PA3E-s27	—	418	S	f1	11	0	0	0
PA-3E	PA3E-s28	—	424	S	c2	20	18	0	0
PA-3E	PA3E-s29	—	429	N	c2	9	22	3	12
PA-3E	PA3E-s30	—	430	—	c1	0	42	0	14
PA-3E	PA3E-s31	—	449	N	c2	30	0	11	0
PA-3E	PA3E-s32	—	455	—	c1	0	41	0	8
PA-3E	PA3E-s33	—	456	S	f1	27	0	9	0
PA-3E	PA3E-s34	—	468	S	c2	31	6	13	6
PA-3E	PA3E-s35	—	481	S	c2	40	0	20	0
PA-3E	PA3E-s36	—	480	—	c1	0	6	0	6
PA-3E	PA3E-s37	—	485	N	c2 swale	34	0	16	0
PA-3E	PA3E-s38	PA-25001	485	N	c2	46	50	25	0
PA-3E	PA3E-s39	—	493	N	c2f	4	0	4	0
PA-3E	PA3E-s40	—	505	—	c1	0	8	0	8
PA-3E	PA3E-s41	—	510	S	c2	24	12	7	0
PA-3E	PA3E-s42	—	519	N	c2	66	6	27	0
PA-3E	PA3E-s43	PA-25004	522	N	f1w	30	0	26	0

Table B-1.0-2 (continued)

Reach	Stratigraphic Description Location	Location ID	Reach Distance (m)	Side of Channel	Geomorphic Unit	Fine Facies Thickness (cm)	Coarse Facies Thickness (cm)	Inferred Post-Fire Fine Facies Thickness (cm) ^a	Inferred Post-Fire Coarse Facies Thickness (cm) ^a
PA-3E	PA3E-s44	—	522	N	f1w	41	0	37	0
PA-3E	PA3E-s45	PA-25003	496	N	f1w	22	0	18	0
PA-3E	PA3E-s46	—	497	N	f1w	13	0	8	0
PA-3E	PA3E-s47	—	470	N	f1w	15	0	10	0
PA-3E	PA3E-s48	—	470	N	f1w	9	0	9	0
PA-3E	PA3E-s49	—	447	N	f1w	5	0	0	0
PA-3E	PA3E-s50	—	357	N	f1w	5	0	0	0
PA-4	PA4-s1	—	24	—	c1	4	4	4	4
PA-4	PA4-s2	PA-22882	25	N	c2	9	30	9	0
PA-4	PA4-s3	—	70	S	c2	16	13	4	0
PA-4	PA4-s4	—	70	—	c1	2	10	2	0
PA-4	PA4-s5	—	90	—	c1 pool	19	0	14	0
PA-4	PA4-s6	—	100	—	c1 pool	15	0	12	0
PA-4	PA4-s7	—	125	N	c1w	31	0	7	0
PA-4	PA4-s8	—	125	C	c1w	15	6	7	0
PA-4	PA4-s9	PA-22883	125	S	c1w	31	4	14	0
PA-4	PA4-s10	—	150	S	c1w	24	0	4	0
PA-4	PA4-s11	—	150	C	c1w	31	3	7	0
PA-4	PA4-s12	PA-22884	150	N	c1w	48	8	6	0
PA-4	PA4-s13	—	175	N	c1w	34	8	4	0
PA-4	PA4-s14	—	175	C	c1w	54	4	4	0
PA-4	PA4-s15	—	175	—	c1	3	0	3	0
PA-4	PA4-s16	—	175	S	c1w	3	0	3	0
PA-4	PA4-s17	—	200	S	c1w	32	10	4	0

Table B-1.0-2 (continued)

Reach	Stratigraphic Description Location	Location ID	Reach Distance (m)	Side of Channel	Geomorphic Unit	Fine Facies Thickness (cm)	Coarse Facies Thickness (cm)	Inferred Post-Fire Fine Facies Thickness (cm) ^a	Inferred Post-Fire Coarse Facies Thickness (cm) ^a
PA-4	PA4-s18	—	200	—	c1	13	4	5	0
PA-4	PA4-s19	PA-22887	200	C	c1w	27	0	2	0
PA-4	PA4-s20	—	200	N	c1w	20	0	3	0
PA-4	PA4-s21	—	214	S	c2	14	0	5	0
PA-4	PA4-s22	—	232	—	c1 pool	38	0	10	0
PA-4	PA4-s23	—	235	S	c2	9	0	5	0
PA-4	PA4-s24	—	256	S	c1 willow	23	18	5	0
PA-4	PA4-s25	18-10096	276	—	c1 willow	16	5	3	0
PA-4	PA4-s26	18-10097	295	—	c1	16	0	1	0
PA-4	PA4-s27	18-10098	317	N	c2	20	4	4	0
PA-4	PA4-s28	—	350	—	c1	3	0	3	0
PA-4	PA4-s29	—	355	N	c2	9	0	4	0
PA-4	PA4-s30	—	395	N	c2	9	4	4	0
PA-4	PA4-s31	—	400	—	c1	14	0	1	0
PA-4	PA4-s32	—	407	S	c2	3	9	3	0
PA-4	PA4-s33	—	450	—	c1	1	2	1	0
PA-4	PA4-s34	PA-22889	453	N	c2	18	0	4	0
PA-4	PA4-s35	—	492	S	c2	20	0	9	0
PA-4	PA4-s36	—	496	N	c2	16	8	6	0
PA-4	PA4-s37	—	500	—	c1	5	0	5	0
PA-4	PA4-s38	—	526	—	c1 pool	4	0	4	0
PA-4	PA4-s39	PA-22890	538	—	c1 pool	35	0	26	0
PA-5W	PA5W-s1	PA-26550	296	S	c2	4	20	0	0
PA-5W	PA5W-s2	PA-26549	295	S	f1	22	2	0	0

Table B-1.0-2 (continued)

Reach	Stratigraphic Description Location	Location ID	Reach Distance (m)	Side of Channel	Geomorphic Unit	Fine Facies Thickness (cm)	Coarse Facies Thickness (cm)	Inferred Post-Fire Fine Facies Thickness (cm) ^a	Inferred Post-Fire Coarse Facies Thickness (cm) ^a
PA-5W	PA5W-s3	—	288	—	c1	0	2	0	2
PA-5W	PA5W-s4	—	272	S	f1	10	0	0	0
PA-5W	PA5W-s5	—	267	N	f1	9	0	0	0
PA-5W	PA5W-s6	—	266	—	c1	5	3	5	3
PA-5W	PA5W-s7	—	255	—	c1	0	4	0	4
PA-5W	PA5W-s8	—	249	S	f1	6	0	0	0
PA-5W	PA5W-s9	—	246	N	f1	16	0	0	0
PA-5W	PA5W-s10	PA-26548	245	N	c1b? (f1 swale?)	13	0	11	0
PA-5W	PA5W-s11	—	235	S	f1	4	0	0	0
PA-5W	PA5W-s12	—	232	N	c1b? (f1 swale?)	10	0	10	0
PA-5W	PA5W-s13	—	232	N	f2	2	0	0	0
PA-5W	PA5W-s14	—	232	—	c1	0	0	0	0
PA-5W	PA5W-s15	—	230	N	c1b? (f1 swale?)	4	0	4	0
PA-5W	PA5W-s16	PA-26546	214	N	f1	14	0	0	0
PA-5W	PA5W-s17	—	219	N	f1	11	0	0	0
PA-5W	PA5W-s18	—	217	—	c1	12	0	7	0
PA-5W	PA5W-s19	—	204	N	f1	5	0	0	0
PA-5W	PA5W-s20	—	195	S	f1	19	0	0	0
PA-5W	PA5W-s21	PA-26545	191	S	c3	0	50	0	0
PA-5W	PA5W-s22	—	192	—	c1	0	2	0	2
PA-5W	PA5W-s23	PA-26544	186	N	c3? (f1?)	24	11	0	0
PA-5W	PA5W-s24	—	176	N	f1	13	0	0	0

Table B-1.0-2 (continued)

Reach	Stratigraphic Description Location	Location ID	Reach Distance (m)	Side of Channel	Geomorphic Unit	Fine Facies Thickness (cm)	Coarse Facies Thickness (cm)	Inferred Post-Fire Fine Facies Thickness (cm) ^a	Inferred Post-Fire Coarse Facies Thickness (cm) ^a
PA-5W	PA5W-s25	—	175	S	f1	8	0	0	0
PA-5W	PA5W-s26	—	164	—	c1	5	4	5	0
PA-5W	PA5W-s27	PA-26543	167	S	c3? (f1?)	20	7	0	0
PA-5W	PA5W-s28	—	156	S	c3? (f1?)	6	7	0	0
PA-5W	PA5W-s29	—	145	N	f1	13	0	6	0
PA-5W	PA5W-s30	—	142	N	c3	0	11	0	0
PA-5W	PA5W-s31	—	138	—	c1	0	11	0	7
PA-5W	PA5W-s32	—	122	S	c3? (f1?)	0	3	0	0
PA-5W	PA5W-s33	—	112	N	f1	30	4	0	0
PA-5W	PA5W-s34	—	107	S	c2	0	8	0	0
PA-5W	PA5W-s35	—	102	—	c1	0	13	0	7
PA-5W	PA5W-s36	—	97	S	f1	16	0	0	0
PA-5W	PA5W-s37	PA-26541	102	S	c3? (f1?)	24	46	0	0
PAS-1E	PAS1E-s1	PA-26418	2	S	c2? (f1?)	42	31	0	0
PAS-1E	PAS1E-s2	—	6	N	c2	63	17	0	2
PAS-1E	PAS1E-s3	—	17	—	c1	13	12	13	3
PAS-1E	PAS1E-s4	—	20	S	c2? (f1?)	65	16	10	3
PAS-1E	PAS1E-s5	—	20	—	c1	18	21	18	4
PAS-1E	PAS1E-s6	—	32	N	c2? (f1?)	35	13	0	0
PAS-1E	PAS1E-s7	—	37	—	c1	2	11	2	6
PAS-1E	PAS1E-s8	—	40	S	c2	58	12	2	0
PAS-1E	PAS1E-s9	—	44	N	c2	41	25	3	0
PAS-1E	PAS1E-s10	—	51	—	c1	9	30	9	13
PAS-1E	PAS1E-s11	—	55	N	c2	37	43	0	0

Table B-1.0-2 (continued)

Reach	Stratigraphic Description Location	Location ID	Reach Distance (m)	Side of Channel	Geomorphic Unit	Fine Facies Thickness (cm)	Coarse Facies Thickness (cm)	Inferred Post-Fire Fine Facies Thickness (cm) ^a	Inferred Post-Fire Coarse Facies Thickness (cm) ^a
PAS-1E	PAS1E-s12	—	65	S	f1	9	0	0	0
PAS-1E	PAS1E-s13	PA-26421	67	S	c2	22	21	0	0
PAS-1E	PAS1E-s14	—	85	N	c2	30	25	0	0
PAS-1E	PAS1E-s15	PA-26423	86	N	f1	27	0	10	0
PAS-1E	PAS1E-s16	—	87	—	c1	9	10	3	3
PAS-1E	PAS1E-s17	—	99	S	c2	40	24	4	2
PAS-1E	PAS1E-s18	—	106	S	f1	7	0	2	0
PAS-1E	PAS1E-s19	—	107	N	c2	40	27	0	0
PAS-1E	PAS1E-s20	PA-26424	105	—	c1	0	30	0	5
PAS-1E	PAS1E-s21	—	128	S	c2	79	8	5	0
PAS-1E	PAS1E-s22	—	137	—	c1	0	30	0	5
PAS-1E	PAS1E-s23	—	138	N	c2? (f1?)	22	3	0	0
PAS-1E	PAS1E-s24	—	135	S	c2	43	5	1	0
PAS-1E	PAS1E-s25	—	160	S	c2	58	3	1	0
PAS-1E	PAS1E-s26	—	162	—	c1	0	20	0	20
PAS-1E	PAS1E-s27	PA-26426	168	N	c2	41	0	0	0
PAS-1E	PAS1E-s28	PA-26427	177	N	c2? (f1?)	26	0	0	0
PAS-1E	PAS1E-s29	—	183	S	c2	12	0	4	0
PAS-1E	PAS1E-s30	—	187	—	c1	0	11	0	4
PAS-2W	PAS2W-s1	—	5	—	c1	0	6	0	0
PAS-2W	PAS2W-s2	PA-24845	8	S	c2	36	19	0	0
PAS-2W	PAS2W-s3	—	12	N	c2	22	25	0	0
PAS-2W	PAS2W-s4	—	16	N	c2	24	7	0	0
PAS-2W	PAS2W-s5	PA-24846	9	N	f1	40	0	0	0

Table B-1.0-2 (continued)

Reach	Stratigraphic Description Location	Location ID	Reach Distance (m)	Side of Channel	Geomorphic Unit	Fine Facies Thickness (cm)	Coarse Facies Thickness (cm)	Inferred Post-Fire Fine Facies Thickness (cm) ^a	Inferred Post-Fire Coarse Facies Thickness (cm) ^a
PAS-2W	PAS2W-s6	—	25	N	f1	17	0	0	0
PAS-2W	PAS2W-s7	—	25	—	c1	9	9	0	0
PAS-2W	PAS2W-s8	—	34	S	c2	18	47	0	0
PAS-2W	PAS2W-s9	PA-24847	43	N	c2	14	53	0	0
PAS-2W	PAS2W-s10	—	46	S	f1	22	5	0	0
PAS-2W	PAS2W-s11	PA-24849	50	—	c1	6	29	0	0
PAS-2W	PAS2W-s12	—	55	S	c1b	18	24	0	0
PAS-2W	PAS2W-s13	—	63	N	f1	45	0	0	0
PAS-2W	PAS2W-s14	PA-24850	67	S	f1	60	0	0	0
PAS-2W	PAS2W-s15	—	72	—	c1	8	7	0	0
PAS-2W	PAS2W-s16	—	86	S	c2	28	27	0	0
PAS-2W	PAS2W-s17	—	95	N	c2	12	12	0	0
PAS-2W	PAS2W-s18	—	100	—	c1	11	6	0	0
PAS-2W	PAS2W-s19	—	103	N	f1	13	0	0	0
PAS-2W	PAS2W-s20	—	107	S	c2	32	15	0	0
PAS-2W	PAS2W-s21	PA-24852	111	N	c2	51	8	0	0
PAS-2W	PAS2W-s22	PA-24853	115	S	f1	42	0	0	0
PAS-2W	PAS2W-s23	—	125	—	c1	0	6	0	0
PAS-2W	PAS2W-s24	—	130	S	f1	10	0	0	0
PAS-2W	PAS2W-s25	—	132	C	c2	7	20	0	0
PAS-2W	PAS2W-s26	—	149	—	c1	0	18	0	0
PAS-2W	PAS2W-s27	PA-24854	150	N	f1	16	0	0	0
PAS-2W	PAS2W-s28	—	163	N	f1	6	0	0	0
PAS-2W	PAS2W-s29	—	160	N	c2	11	4	0	0

Table B-1.0-2 (continued)

Reach	Stratigraphic Description Location	Location ID	Reach Distance (m)	Side of Channel	Geomorphic Unit	Fine Facies Thickness (cm)	Coarse Facies Thickness (cm)	Inferred Post-Fire Fine Facies Thickness (cm) ^a	Inferred Post-Fire Coarse Facies Thickness (cm) ^a
PAS-2W	PAS2W-s30	—	173	—	c1	0	11	0	0
PAS-2W	PAS2W-s31	—	187	N	c2	3	25	0	0
PAS-2W	PAS2W-s32	—	195	S	c2	14	35	0	0
PAS-2W	PAS2W-s33	—	197	N	f1	3	6	0	0
PAS-2W	PAS2W-s34	—	199	—	c1	1	19	0	0
TH-1C	TH1C-s1	—	182	N	c2	32	56	11	12
TH-1C	TH1C-s2	—	180	S	c2a	5	20	2	20
TH-1C	TH1C-s3	TH-26437	179	—	c1	27	35	0	14
TH-1C	TH1C-s4	TH-26436	168	—	c2	33	10	8	0
TH-1C	TH1C-s5	—	154	—	c1	8	10	3	10
TH-1C	TH1C-s6	—	150	S	c2	14	14	5	0
TH-1C	TH1C-s7	—	140	N	f1	17	0	3	0
TH-1C	TH1C-s8	TH-26435	138	—	c2	40	12	9	9
TH-1C	TH1C-s9	—	134	N	c2a	5	5	0	5
TH-1C	TH1C-s10	—	129	—	c1	8	9	3	9
TH-1C	TH1C-s11	—	127	—	c2	29	28	13	0
TH-1C	TH1C-s12	—	106	—	c2	42	34	8	0
TH-1C	TH1C-s13	—	90	—	c2	27	18	3	13
TH-1C	TH1C-s14	—	78	—	c1	4	24	4	11
TH-1C	TH1C-s15	TH-26433	76	—	c2	53	2	3	0
TH-1C	TH1C-s16	—	62	—	c2	75	42	7	4
TH-1C	TH1C-s17	—	54	S	f1	16	1	0	1
TH-1C	TH1C-s18	TH-26431	50	—	c2	31	18	9	10
TH-1C	TH1C-s19	—	36	—	c1	5	15	3	0

Table B-1.0-2 (continued)

Reach	Stratigraphic Description Location	Location ID	Reach Distance (m)	Side of Channel	Geomorphic Unit	Fine Facies Thickness (cm)	Coarse Facies Thickness (cm)	Inferred Post-Fire Fine Facies Thickness (cm) ^a	Inferred Post-Fire Coarse Facies Thickness (cm) ^a
TH-1C	TH1C-s20	TH-26429	26	S	c2	37	33	5	0
TH-1C	TH1C-s21	TH-26428	14	—	c2	36	12	10	0
TH-1C	TH1C-s22	—	2	—	c2	35	72	6	0
TH-1E	TH1E-s1	TH-25016	187	—	c2	64	11	10	0
TH-1E	TH1E-s2	—	175	S	f1	3	0	3	0
TH-1E	TH1E-s3	—	169	—	c1	34	8	5	0
TH-1E	TH1E-s4	TH-25015	169	—	c2	41	27	10	0
TH-1E	TH1E-s5	-	145	—	c1	52	9	3	5
TH-1E	TH1E-s6	TH-25014	144	—	c2	54	17	7	0
TH-1E	TH1E-s7	TH-25013	133	N	f1	30	0	6	0
TH-1E	TH1E-s8	TH-25012	121	—	c1	31	8	3	11
TH-1E	TH1E-s9	TH-25010	111	—	c2	46	19	27	0
TH-1E	TH1E-s10	—	110	S	f1	11	0	4	0
TH-1E	TH1E-s11	—	95	S	f1	38	0	20	0
TH-1E	TH1E-s12	—	90	—	c2	28	13	10	0
TH-1E	TH1E-s13	—	89	N	f1	11	4	3	4
TH-1E	TH1E-s14	—	77	S	f1	16	0	0	0
TH-1E	TH1E-s15	—	73	—	c1	14	28	3	0
TH-1E	TH1E-s16	—	54	—	c2	32	21	7	0
TH-1E	TH1E-s17	—	35	?	f1	13	0	0	0
TH-1E	TH1E-s18	TH-25009	33	—	c2	27	73	8	12
TH-1E	TH1E-s19	TH-25007	10	—	c2	59	31	13	0
THM-1	THM1-s1	TH-25017	4	N	c2	47	38	0	0
THM-1	THM1-s2	—	6	S	c2	36	18	0	0

Table B-1.0-2 (continued)

Reach	Stratigraphic Description Location	Location ID	Reach Distance (m)	Side of Channel	Geomorphic Unit	Fine Facies Thickness (cm)	Coarse Facies Thickness (cm)	Inferred Post-Fire Fine Facies Thickness (cm) ^a	Inferred Post-Fire Coarse Facies Thickness (cm) ^a
THM-1	THM1-s3	TH-25019	9	N	f1	35	0	7	0
THM-1	THM1-s4	—	16	—	c1	0	28	0	7
THM-1	THM1-s5	—	41	—	c1	2	33	0	3
THM-1	THM1-s6	TH-25020	42	S	f1	32	0	6	0
THM-1	THM1-s7	—	49	S	f1	33	0	0	0
THM-1	THM1-s8	—	55	N	c2? (f1?)	57	16	6	0
THM-1	THM1-s9	—	64	—	c1	3	13	3	13
THM-1	THM1-s10	—	62	N	c2	6	37	0	0
THM-1	THM1-s11	—	70	S	c2	13	112	0	0
THM-1	THM1-s12	TH-25021	85	S	c2? (c3?)	22	36	0	0
THM-1	THM1-s13	—	88	—	c1	0	9	0	9
THM-1	THM1-s14	—	90	N	f1	27	6	5	6
THM-1	THM1-s15	—	93	N	c2? (c3?)	18	36	0	0
THM-1	THM1-s16	TH-25022	100	—	c1	0	24	0	0
THM-1	THM1-s17	—	108	N	c2? (c3?)	15	29	0	0
THM-1	THM1-s18	—	110	S	c2? (c3?)	21	21	0	0
THM-1	THM1-s19	—	116	N	c2	59	30	2	7
THM-1	THM1-s20	TH-25023	117	S	c2? (c3?)	26	33	0	15
THM-1	THM1-s21	—	119	—	c1	0	40	0	7
THM-1	THM1-s22	—	120	N	f1	44	5	4	0
THM-1	THM1-s23	—	126	S	c2	35	47	5	12
THM-1	THM1-s24	TH-25024	133	N	c2	55	19	0	0
THM-1	THM1-s25	—	133	S	c2	9	44	0	0
THM-1	THM1-s26	—	138	—	c1	0	12	0	4

Table B-1.0-2 (continued)

Reach	Stratigraphic Description Location	Location ID	Reach Distance (m)	Side of Channel	Geomorphic Unit	Fine Facies Thickness (cm)	Coarse Facies Thickness (cm)	Inferred Post-Fire Fine Facies Thickness (cm) ^a	Inferred Post-Fire Coarse Facies Thickness (cm) ^a
THM-1	THM1-s27	—	147	S	c2? (c3?)	21	24	0	0
THM-1	THM1-s28	—	159	N	f1	12	6	4	0
THM-1	THM1-s29	—	160	—	c1	0	61	0	18
THM-1	THM1-s30	—	170	S	c2	9	50	0	9
THM-1	THM1-s31	—	172	—	c1	0	15	0	15
THM-1	THM1-s32	—	178	S	c2? (c3?)	23	33	0	0
THM-1	THM1-s33	—	188	S	c2? (c3?)	14	42	0	0
THM-1	THM1-s34	TH-25025	185	N	c2? (c3?)	46	19	10	0
THM-1	THM1-s35	—	191	N	c2	20	23	15	0
THM-1	THM1-s36	TH-25026	192	S	c2	10	71	0	0
THM-1	THM1-s37	—	195	—	c1	0	12	0	0
THS-1E	THS1E-s1	—	1	S	f1	18	0	7	0
THS-1E	THS1E-s2	TH-25027	3	S	c2	48	14	7	0
THS-1E	THS1E-s3	—	5	S	f1	12	3	0	0
THS-1E	THS1E-s4	—	3	N	c1b	0	14	0	0
THS-1E	THS1E-s5	—	12	—	c1	0	19	0	0
THS-1E	THS1E-s6	—	22	S	c2	28	11	6	0
THS-1E	THS1E-s7	—	35	S	c2	26	57	4	0
THS-1E	THS1E-s8	—	37	N	c2	18	25	3	0
THS-1E	THS1E-s9	—	37	—	c1	5	27	0	5
THS-1E	THS1E-s10	—	45	S	c2	19	4	4	0
THS-1E	THS1E-s11	TH-25028	49	N	c1b	25	60	0	0
THS-1E	THS1E-s12	—	62	—	c1	36	48	0	0
THS-1E	THS1E-s14	—	64	N	c2	14	77	0	0

Table B-1.0-2 (continued)

Reach	Stratigraphic Description Location	Location ID	Reach Distance (m)	Side of Channel	Geomorphic Unit	Fine Facies Thickness (cm)	Coarse Facies Thickness (cm)	Inferred Post-Fire Fine Facies Thickness (cm) ^a	Inferred Post-Fire Coarse Facies Thickness (cm) ^a
THS-1E	THS1E-s15	—	75	N	c1b	33	70	9	4
THS-1E	THS1E-s16	TH-25030	86	—	c1	0	90	0	0
THS-1E	THS1E-s17	—	89	S	c2	14	17	0	0
THS-1E	THS1E-s18	—	96	N	c1b	45	44	0	0
THS-1E	THS1E-s19	—	107	N	c2	66	34	0	0
THS-1E	THS1E-s20	—	112	—	c1	18	69	0	3
THS-1E	THS1E-s21	TH-25031	118	N	c2	50	29	2	0
THS-1E	THS1E-s22	—	129	S	c2	51	7	2	0
THS-1E	THS1E-s23	—	137	—	c1	6	65	0	0
THS-1E	THS1E-s24	—	143	N	c2	47	48	0	0
THS-1E	THS1E-s25	—	161	S	c2	73	41	0	0
THS-1E	THS1E-s26	—	162	—	c1	0	75	0	0
THS-1E	THS1E-s27	TH-25034	176	N	c2	75	11	0	0
THS-1E	THS1E-s28	TH-25036	184	S	f1	38	0	2	0
THS-1E	THS1E-s29	—	184	N	c2	56	20	0	0
THS-1E	THS1E-s30	—	187	—	c1	47	42	3	2
THS-1E	THS1E-s31	—	189	S	c2	27	30	0	0
THS-1W	THS1W-s1	—	5	N	f1	11	10	0	0
THS-1W	THS1W-s2	—	4	S	c2	31	9	0	0
THS-1W	THS1W-s3	TH-26438	12	—	c1	0	32	0	0
THS-1W	THS1W-s4	—	14	N	c2	20	34	0	0
THS-1W	THS1W-s5	—	20	S	c2	13	19	0	0
THS-1W	THS1W-s6	TH-26439	29	N	c2	42	12	0	0
THS-1W	THS1W-s7	—	31	—	f1	14	0	0	0

Table B-1.0-2 (continued)

Reach	Stratigraphic Description Location	Location ID	Reach Distance (m)	Side of Channel	Geomorphic Unit	Fine Facies Thickness (cm)	Coarse Facies Thickness (cm)	Inferred Post-Fire Fine Facies Thickness (cm) ^a	Inferred Post-Fire Coarse Facies Thickness (cm) ^a
THS-1W	THS1W-s8	—	37	—	c1	1	11	0	0
THS-1W	THS1W-s9	—	48	S	c2	23	9	0	0
THS-1W	THS1W-s10	TH-26441	59	N	c2	2	13	0	0
THS-1W	THS1W-s11	—	60	—	c1	0	25	0	0
THS-1W	THS1W-s12	—	69	N	c2	23	6	0	0
THS-1W	THS1W-s13	—	71	N	f1? (c3?)	12	11	0	0
THS-1W	THS1W-s14	—	73	—	c1	0	39	0	0
THS-1W	THS1W-s15	TH-26442	77	N	f1	15	0	0	0
THS-1W	THS1W-s16	TH-26443	89	S	c2	32	7	0	0
THS-1W	THS1W-s17	—	92	N	f1	13	0	0	0
THS-1W	THS1W-s18	TH-26444	100	—	c1	0	10	0	0
THS-1W	THS1W-s19	—	100	N	f1	6	0	0	0
THS-1W	THS1W-s20	—	107	N	c2	38	5	0	0
THS-1W	THS1W-s21	—	122	S	f1? (c3?)	37	0	0	0
THS-1W	THS1W-s22	—	140	—	c1	0	12	0	0
THS-1W	THS1W-s23	—	137	N	c2	13	11	0	0
THS-1W	THS1W-s24	—	142	S	f1	8	0	0	0
THS-1W	THS1W-s25	TH-26445	153	S	f1	29	4	0	0
THS-1W	THS1W-s26	—	155	—	c1	3	30	0	0
THS-1W	THS1W-s27	—	175	N	c2	4	20	0	0
THS-1W	THS1W-s28	—	175	—	c1	13	47	0	0
THS-1W	THS1W-s29	TH-26446	181	S	c2	45	16	0	0
THS-1W	THS1W-s30	—	187	N	c2	29	23	0	0
THS-1W	THS1W-s31	—	191	S	f1	3	0	0	0

Table B-1.0-2 (continued)

Reach	Stratigraphic Description Location	Location ID	Reach Distance (m)	Side of Channel	Geomorphic Unit	Fine Facies Thickness (cm)	Coarse Facies Thickness (cm)	Inferred Post-Fire Fine Facies Thickness (cm) ^a	Inferred Post-Fire Coarse Facies Thickness (cm) ^a
THS-1W	THS1W-s32	—	200	S	c2	0	33	0	0
THS-1W	THS1W-s33	TH-26447	200	N	f1	42	5	0	0
THS-1W	THS1W-s34	—	202	—	c1	3	24	0	0
THW-1	THW1-s1	—	186	—	c1	9	32	4	11
THW-1	THW1-s2	TH-26456	183	W	f1	26	0	13	0
THW-1	THW1-s3	—	179	E	f1	37	0	14	0
THW-1	THW1-s4	—	175	—	c1	0	17	0	17
THW-1	THW1-s5	—	174	W	f1	14	0	14	0
THW-1	THW1-s6	—	165	E	f1	18	0	3	0
THW-1	THW1-s7	—	159	—	c2	29	8	0	0
THW-1	THW1-s8	TH-26455	158	W	f1	45	0	4	0
THW-1	THW1-s9	—	144	—	c2	35	31	8	3
THW-1	THW1-s10	—	143	W	f1	15	0	4	0
THW-1	THW1-s11	—	138	E	f1	11	0	7	0
THW-1	THW1-s12	—	135	W	f1	31	0	16	0
THW-1	THW1-s13	TH-26454	130	—	c2	40	33	7	8
THW-1	THW1-s14	—	124	E	f1	8	0	8	0
THW-1	THW1-s15	TH-26452	122	—	c1	25	18	0	18
THW-1	THW1-s16	—	115	E	c2	25	5	14	5
THW-1	THW1-s17	—	106	W	c2	17	0	5	0
THW-1	THW1-s18	—	99	E	f1	8	0	8	0
THW-1	THW1-s19	—	98	—	c1	16	19	0	9
THW-1	THW1-s20	TH-26451	92	E	f1	8	0	8	0
THW-1	THW1-s21	—	83	E	f1	22	18	15	0

Table B-1.0-2 (continued)

Reach	Stratigraphic Description Location	Location ID	Reach Distance (m)	Side of Channel	Geomorphic Unit	Fine Facies Thickness (cm)	Coarse Facies Thickness (cm)	Inferred Post-Fire Fine Facies Thickness (cm) ^a	Inferred Post-Fire Coarse Facies Thickness (cm) ^a
THW-1	THW1-s22	—	78	E	c2? (f1?)	31	9	0	9
THW-1	THW1-s23	—	70	—	c1	21	37	0	16
THW-1	THW1-s24	—	58	E	c2? (f1?)	32	38	12	6
THW-1	THW1-s25	—	46	E?	c2? (f1?)	0	10	0	10
THW-1	THW1-s26	—	54	—	c1	7	8	0	8
THW-1	THW1-s27	—	40	—	c1	7	23	0	2
THW-1	THW1-s28	—	31	E?	c2? (f1?)	19	9	1	1
THW-1	THW1-s29	TH-26448	23	E	c2	29	51	2	4
THW-1	THW1-s30	—	20	W?	c2? (f1?)	8	13	5	2
THW-1	THW1-s31	—	11	—	c1	15	0	5	0
THW-1	THW1-s32	—	9	W	f1? (c2?)	20	0	4	0
THW-1	THW1-s33	TH-26450	74	E	c2	43	72	8	13
TW-1E	TW1E-s1	—	5	—	c1	0	41	0	0
TW-1E	TW1E-s2	—	9	S	c2	11	15	0	0
TW-1E	TW1E-s3	—	23	S	c1b	12	16	0	0
TW-1E	TW1E-s4	—	37	N	f1	18	20	0	0
TW-1E	TW1E-s5	TW-24825	40	S	f1	23	8	0	0
TW-1E	TW1E-s6	TW-24826	45	-	c1	0	27	0	0
TW-1E	TW1E-s7	—	58	N	c2	7	22	3	22
TW-1E	TW1E-s8	—	64	—	c1	0	55	0	30
TW-1E	TW1E-s9	—	72	N	c2	9	13	0	0
TW-1E	TW1E-s10	TW-24827	82	S	c2	15	23	0	0
TW-1E	TW1E-s11	—	86	S	f1	10	0	0	0
TW-1E	TW1E-s12	—	88	—	c1	0	30	0	0

Table B-1.0-2 (continued)

Reach	Stratigraphic Description Location	Location ID	Reach Distance (m)	Side of Channel	Geomorphic Unit	Fine Facies Thickness (cm)	Coarse Facies Thickness (cm)	Inferred Post-Fire Fine Facies Thickness (cm) ^a	Inferred Post-Fire Coarse Facies Thickness (cm) ^a
TW-1E	TW1E-s13	TW-24829	94	S	c2	27	29	0	0
TW-1E	TW1E-s14	TW-24830	96	S	f1	23	0	0	0
TW-1E	TW1E-s15	TW-24831	104	S	c1b	0	34	0	20
TW-1E	TW1E-s16	TW-24832	104	S	c2	29	20	3	10
TW-1E	TW1E-s17	TW-24833	128	—	c1	0	38	0	0
TW-1E	TW1E-s18	—	129	S	f1	11	0	0	0
TW-1E	TW1E-s19	—	144	—	c1	0	42	0	0
TW-1E	TW1E-s20	—	149	N	f1	7	10	0	0
TW-1E	TW1E-s21	—	168	—	c1	0	13	0	0
TW-1E	TW1E-s22	—	175	N	c1b	0	12	0	0
TW-1E	TW1E-s23	—	180	S	c2	6	8	6	8
TW-1E	TW1E-s24	—	181	S	c1b	0	69	0	0
TW-1E	TW1E-s25	TW-24834	189	N	c2	7	73	0	0
TW-1E	TW1E-s26	—	192	—	c1	4	33	0	0
TW-1E	TW1E-s27	—	201	S	c2	14	51	6	25
TW-1E	TW1E-s29	—	76	N	f1	9	8	2	8
TW-1E	TW1E-s30	—	116	N	f1	11	6	0	0
TW-1E	TW1E-s31	—	31	S	c2	9	41	0	0
TW-1W	TW1W-s1	—	12	—	c1	0	18	0	18
TW-1W	TW1W-s2	—	16	S	c2	21	13	0	12
TW-1W	TW1W-s3	—	25	N	c2	0	31	0	16
TW-1W	TW1W-s4	TW-26458	35	—	c1	0	27	0	27
TW-1W	TW1W-s5	—	43	S	f1	6	0	6	0
TW-1W	TW1W-s6	TW-26459	48	S	c3	0	105	0	0

Table B-1.0-2 (continued)

Reach	Stratigraphic Description Location	Location ID	Reach Distance (m)	Side of Channel	Geomorphic Unit	Fine Facies Thickness (cm)	Coarse Facies Thickness (cm)	Inferred Post-Fire Fine Facies Thickness (cm) ^a	Inferred Post-Fire Coarse Facies Thickness (cm) ^a
TW-1W	TW1W-s7	—	53	N	c2	4	25	4	25
TW-1W	TW1W-s8	—	57	—	c1	0	17	0	17
TW-1W	TW1W-s9	—	64	N	f1	15	8	8	0
TW-1W	TW1W-s10	—	71	N	f1	12	11	2	0
TW-1W	TW1W-s11	TW-26460	82	N	f1	13	0	2	0
TW-1W	TW1W-s12	—	88	N	c3	18	122	0	0
TW-1W	TW1W-s13	—	87	—	c1	0	10	0	10
TW-1W	TW1W-s14	—	94	S	c3	0	82	0	0
TW-1W	TW1W-s15	TW-26461	110	S	c2	3	65	3	15
TW-1W	TW1W-s16	—	112	—	c1	0	20	0	20
TW-1W	TW1W-s17	—	113	S	f1	12	0	8	0
TW-1W	TW1W-s18	TW-26462	121	N	f1	31	9	12	0
TW-1W	TW1W-s19	—	137	—	c1	0	25	0	25
TW-1W	TW1W-s20	—	152	S	c2	9	37	0	0
TW-1W	TW1W-s21	TW-26464	162	—	c1	0	35	0	35
TW-1W	TW1W-s22	—	165	N	c2	27	21	0	21
TW-1W	TW1W-s23	—	173	N	f1? (c2?)	6	19	0	19
TW-1W	TW1W-s24	—	181	N	c2 swale	0	36	0	0
TW-1W	TW1W-s25	—	187	—	c1	0	25	0	25
TW-1W	TW1W-s26	TW-26465	183	N	c2	12	50	7	26
TW-1W	TW1W-s27	—	187	N	c2	10	33	0	0
TW-1W	TW1W-s28	TW-26467	191	S	f1	30	0	25	0
TW-2E	TW2E-s1	—	4	S	f1	14	14	0	14
TW-2E	TW2E-s2	—	8	N	c2	17	23	23	0

Table B-1.0-2 (continued)

Reach	Stratigraphic Description Location	Location ID	Reach Distance (m)	Side of Channel	Geomorphic Unit	Fine Facies Thickness (cm)	Coarse Facies Thickness (cm)	Inferred Post-Fire Fine Facies Thickness (cm) ^a	Inferred Post-Fire Coarse Facies Thickness (cm) ^a
TW-2E	TW2E-s3	—	8	N	f1	31	0	0	0
TW-2E	TW2E-s4	—	14	S	c2	59	13	0	13
TW-2E	TW2E-s5	—	20	N	f1	24	0	0	0
TW-2E	TW2E-s6	—	35	N	c2	57	0	0	0
TW-2E	TW2E-s7	—	32	N	c3	34	36	0	36
TW-2E	TW2E-s8	—	37	N	f1	14	0	0	0
TW-2E	TW2E-s9	TW-601031	44	N	f1	33	0	0	0
TW-2E	TW2E-s10	—	50	S	c2	44	6	2	4
TW-2E	TW2E-s11	TW-601032	56	N	c2	48	25	0	25
TW-2E	TW2E-s12	—	66	S	f1	31	0	0	0
TW-2E	TW2E-s13	—	71	N	c3	80	10	0	10
TW-2E	TW2E-s14	TW-601033	80	N	c3	69	24	0	24
TW-2E	TW2E-s15	—	89	N	f2	2	0	0	0
TW-2E	TW2E-s16	—	89	S	f1	13	0	0	0
TW-2E	TW2E-s17	—	97	S	c2	53	15	0	15
TW-2E	TW2E-s18	—	87	N	f1	9	0	0	0
TW-2E	TW2E-s19	—	101	N	c3	27	13	0	13
TW-2E	TW2E-s20	—	102	N	f1	14	0	0	0
TW-2E	TW2E-s21	—	112	S	f1	17	0	0	0
TW-2E	TW2E-s22	—	120	N	c2	20	0	0	0
TW-2E	TW2E-s23	—	135	N	c2	21	16	0	16
TW-2E	TW2E-s24	—	141	N	c2	77	9	0	9
TW-2E	TW2E-s25	—	145	S	c2	21	0	0	0
TW-2E	TW2E-s26	—	146	S	f1	20	0	0	0

Table B-1.0-2 (continued)

Reach	Stratigraphic Description Location	Location ID	Reach Distance (m)	Side of Channel	Geomorphic Unit	Fine Facies Thickness (cm)	Coarse Facies Thickness (cm)	Inferred Post-Fire Fine Facies Thickness (cm) ^a	Inferred Post-Fire Coarse Facies Thickness (cm) ^a
TW-2E	TW2E-s27	—	150	S	c2	48	0	0	0
TW-2E	TW2E-s28	—	164	N	f1	8	0	0	0
TW-2E	TW2E-s29	—	166	S	f1	26	0	0	0
TW-2E	TW2E-s30	—	166	N	c2	15	69	0	69
TW-2E	TW2E-s31	TW-601037	171	S	f1	34	0	0	0
TW-2E	TW2E-s32	TW-601038	180	S	c2	48	22	0	22
TW-2E	TW2E-s33	TW-601040	180	N	f1	23	0	0	0
TW-2E	TW2E-s34	—	192	S	f1	25	0	0	0
TW-2E	TW2E-s35	—	192	N	f1	25	0	0	0
TW-2E	TW2E-s36	—	197	N	c2	30	40	0	40
TW-3E	TW3E-s1	—	2	N	f1	50	18	50	0
TW-3E	TW3E-s2	—	10	N	c2	0	60	0	40
TW-3E	TW3E-s3	—	10	-	c1	0	40	0	40
TW-3E	TW3E-s4	TW-26551	15	N	f1	39	0	7	0
TW-3E	TW3E-s5	—	20	N	c2	6	18	0	0
TW-3E	TW3E-s6	—	30	S	c2	9	21	0	0
TW-3E	TW3E-s7	TW-26552	30	—	c1	0	52	0	52
TW-3E	TW3E-s8	—	32	N	f1	32	28	9	0
TW-3E	TW3E-s9	TW-26553	48	S	f1	85	0	0	0
TW-3E	TW3E-s10	—	52	—	c1	5	38	5	20
TW-3E	TW3E-s11	—	67	N	f1	95	0	13	0
TW-3E	TW3E-s12	—	78	S	f1? (c2?)	34	20	4	23
TW-3E	TW3E-s13	—	85	—	c1	0	32	0	32
TW-3E	TW3E-s14	—	86	N	f1	70	0	0	0

Table B-1.0-2 (continued)

Reach	Stratigraphic Description Location	Location ID	Reach Distance (m)	Side of Channel	Geomorphic Unit	Fine Facies Thickness (cm)	Coarse Facies Thickness (cm)	Inferred Post-Fire Fine Facies Thickness (cm) ^a	Inferred Post-Fire Coarse Facies Thickness (cm) ^a
TW-3E	TW3E-s15	—	91	N	c2	67	8	32	0
TW-3E	TW3E-s16	TW-26554	101	S	f1	37	0	31	0
TW-3E	TW3E-s17	TW-26555	103	—	c1	0	50	0	50
TW-3E	TW3E-s18	—	104	N	f2? (f1?)	2	0	2	0
TW-3E	TW3E-s19	TW-26556	108	N	c2	40	10	12	0
TW-3E	TW3E-s20	—	112	S	f1	45	0	20	0
TW-3E	TW3E-s21	—	115	N	f1	51	0	5	0
TW-3E	TW3E-s22	—	115	N	f1	30	0	28	0
TW-3E	TW3E-s23	—	118	—	c1	0	30	0	30
TW-3E	TW3E-s24	—	122	S	c2	13	33	13	4
TW-3E	TW3E-s25	—	132	N	f1	68	0	20	0
TW-3E	TW3E-s26	TW-26557	134	S	f1	65	0	25	0
TW-3E	TW3E-s27	—	150	—	c1	26	60	26	60
TW-3E	TW3E-s28	—	154	N	f1	77	0	0	0
TW-3E	TW3E-s29	TW-26558	154	S	f1	69	0	0	0
TW-3E	TW3E-s30	—	155	S	f2	3	0	0	0
TW-3E	TW3E-s31	—	172	-	c1	12	28	12	28
TW-3E	TW3E-s32	—	173	S	f1	20	0	11	0
TW-3E	TW3E-s33	—	174	S	f1	15	0	0	0
TW-3E	TW3E-s34	—	188	N	f1	16	0	0	0
TW-3E	TW3E-s35	TW-26560	191	N	c2	8	72	8	38
TW-3E	TW3E-s36	—	193	—	c1	0	14	0	14
TW-3E	TW3E-s37	—	197	S	f1	49	0	0	0
TW-4W	TW4W-s1	—	3	N	c2	20	19	0	0

Table B-1.0-2 (continued)

Reach	Stratigraphic Description Location	Location ID	Reach Distance (m)	Side of Channel	Geomorphic Unit	Fine Facies Thickness (cm)	Coarse Facies Thickness (cm)	Inferred Post-Fire Fine Facies Thickness (cm) ^a	Inferred Post-Fire Coarse Facies Thickness (cm) ^a
TW-4W	TW4W-s2	—	8	S	f1	34	0	0	0
TW-4W	TW4W-s3	—	10	S	c2	24	50	24	0
TW-4W	TW4W-s4	TW-24945	22	N	c2	17	50	17	0
TW-4W	TW4W-s5	—	30	S	c2	10	50	0	0
TW-4W	TW4W-s6	—	24	S	f1	18	24	5	24
TW-4W	TW4W-s7	—	39	N	c2	27	50	15	0
TW-4W	TW4W-s8	—	41	S	c2	13	24	0	0
TW-4W	TW4W-s9	—	52	N	c2	37	45	20	0
TW-4W	TW4W-s10	—	66	S	c3	32	75	1	26
TW-4W	TW4W-s11	TW-10011	71	N	f1	38	13	0	0
TW-4W	TW4W-s12	—	81	N	f1	35	0	0	0
TW-4W	TW4W-s13	—	85	N	c2	26	24	17	0
TW-4W	TW4W-s14	TW-24946	89	N	c3	73	50	13	0
TW-4W	TW4W-s15	—	96	S	c3	58	42	0	0
TW-4W	TW4W-s16	—	105	N	c3	62	28	0	0
TW-4W	TW4W-s17	TW-10010	112	S	c2? (c3?)	33	23	9	0
TW-4W	TW4W-s18	TW-24948	115	S	f1	27	0	0	0
TW-4W	TW4W-s19	—	120	N	c2	51	30	11	0
TW-4W	TW4W-s20	—	125	N	f1	36	0	0	0
TW-4W	TW4W-s21	TW-10009	128	N	c2	20	30	0	0
TW-4W	TW4W-s22	TW-10008	139	S	f1	31	20	0	0
TW-4W	TW4W-s23	—	141	N	c2	32	30	14	0
TW-4W	TW4W-s24	TW-24949	143	S	c2	36	30	26	0
TW-4W	TW4W-s25	—	147	S	f2? (f1?)	33	0	0	0

Table B-1.0-2 (continued)

Reach	Stratigraphic Description Location	Location ID	Reach Distance (m)	Side of Channel	Geomorphic Unit	Fine Facies Thickness (cm)	Coarse Facies Thickness (cm)	Inferred Post-Fire Fine Facies Thickness (cm) ^a	Inferred Post-Fire Coarse Facies Thickness (cm) ^a
TW-4W	TW4W-s26	—	116	S	f1	17	0	0	0
TW-4W	TW4W-s27	TW-10007	158	S	c2	53	30	17	0
TW-4W	TW4W-s28	—	163	S	f1	42	0	0	0
TW-4W	TW4W-s29	TW-10006	169	N	c2	56	30	14	0
TW-4W	TW4W-s30	—	175	S	c2	55	15	0	0
TW-4W	TW4W-s31	—	187	N	f2? (f1?)	8	0	0	0
TW-4W	TW4W-s32	—	187	S	c2	18	50	3	15
TW-4W	TW4W-s33	TW-10005	192	N	c2	25	50	25	0
TW-4W	TW4W-s34	—	193	N	f1	25	0	0	0
TW-4W	TW4W-s35	TW-24950	184	—	c1	0	>10	0	10
TWN-1E	TWN1E-s1	—	8	S	c3	11	49	0	0
TWN-1E	TWN1E-s2	—	12	N	c2	0	40	0	0
TWN-1E	TWN1E-s3	—	13	N	f1	27	0	0	0
TWN-1E	TWN1E-s4	—	19	S	f1	22	0	22	0
TWN-1E	TWN1E-s5	—	22	N	c2	0	32	0	0
TWN-1E	TWN1E-s6	—	29	N	f1	38	13	0	0
TWN-1E	TWN1E-s7	—	31	N	f1	29	0	0	0
TWN-1E	TWN1E-s8	—	51	N	f1	23	19	23	19
TWN-1E	TWN1E-s9	—	60	—	c1	8	92	0	0
TWN-1E	TWN1E-s10	TW-24835	70	N	f1	37	11	0	0
TWN-1E	TWN1E-s11	—	72	S	c2	23	37	0	0
TWN-1E	TWN1E-s12	TW-24836	76	—	c1	48	54	0	0
TWN-1E	TWN1E-s13	TW-24837	86	—	c1	25	53	0	0
TWN-1E	TWN1E-s14	—	104	S	f1	8	7	0	0

Table B-1.0-2 (continued)

Reach	Stratigraphic Description Location	Location ID	Reach Distance (m)	Side of Channel	Geomorphic Unit	Fine Facies Thickness (cm)	Coarse Facies Thickness (cm)	Inferred Post-Fire Fine Facies Thickness (cm) ^a	Inferred Post-Fire Coarse Facies Thickness (cm) ^a
TWN-1E	TWN1E-s15	TW-24839	108	S	f1	22	0	0	0
TWN-1E	TWN1E-s16	—	112	—	c1	0	36	0	0
TWN-1E	TWN1E-s17	—	119	N	f1	16	0	0	0
TWN-1E	TWN1E-s18	—	129	N	c2	11	26	0	0
TWN-1E	TWN1E-s19	—	139	S	f1	37	24	0	0
TWN-1E	TWN1E-s20	—	144	S	c2	3	39	0	0
TWN-1E	TWN1E-s21	—	160	S	f1	22	13	3	0
TWN-1E	TWN1E-s22	—	165	S	c3	37	49	0	0
TWN-1E	TWN1E-s23	TW-24840	166	N	f1	44	12	0	0
TWN-1E	TWN1E-s24	TW-24841	168	—	c1	0	57	0	0
TWN-1E	TWN1E-s25	—	174	S	f1	16	0	0	0
TWN-1E	TWN1E-s26	—	180	N	c3	28	62	0	0
TWN-1E	TWN1E-s27	—	184	N	c2	14	11	10	12
TWN-1E	TWN1E-s28	TW-24842	187	S	c3	28	42	0	0
TWN-1E	TWN1E-s29	TW-24844	195	N	c2	25	17	25	0
TWN-1E	TWN1E-s30	—	171	N	f1	27	0	0	0
TWN-1W	TWN1W-s1	TW-26470	10	N	c2	42	21	15	0
TWN-1W	TWN1W-s2	—	12	—	c1	5	25	5	25
TWN-1W	TWN1W-s3	—	15	S	c2	23	8	0	0
TWN-1W	TWN1W-s4	TW-26472	32	S	f1	33	0	0	0
TWN-1W	TWN1W-s5	—	37	—	c1	1	69	1	27
TWN-1W	TWN1W-s6	TW-26473	48	—	c1	23	23	13	11
TWN-1W	TWN1W-s7	—	58	N	f1	22	0	13	0
TWN-1W	TWN1W-s8	—	62	—	c1	34	56	4	14

Table B-1.0-2 (continued)

Reach	Stratigraphic Description Location	Location ID	Reach Distance (m)	Side of Channel	Geomorphic Unit	Fine Facies Thickness (cm)	Coarse Facies Thickness (cm)	Inferred Post-Fire Fine Facies Thickness (cm) ^a	Inferred Post-Fire Coarse Facies Thickness (cm) ^a
TWN-1W	TWN1W-s9	—	73	N	c2	23	27	6	6
TWN-1W	TWN1W-s10	TW-26474	73	S	c2	11	48	7	0
TWN-1W	TWN1W-s11	—	80	N	c2	24	25	0	0
TWN-1W	TWN1W-s12	—	87	—	c1	0	56	0	56
TWN-1W	TWN1W-s13	—	88	S	c2a	19	24	19	0
TWN-1W	TWN1W-s14	—	95	N	c2a	23	23	0	0
TWN-1W	TWN1W-s15	TW-26475	106	—	c1	0	26	0	26
TWN-1W	TWN1W-s16	—	113	N	c2	0	12	0	0
TWN-1W	TWN1W-s17	—	115	N	c2 swale	0	20	0	0
TWN-1W	TWN1W-s18	—	122	S	f1	23	0	8	0
TWN-1W	TWN1W-s19	—	122	N	c2	22	78	0	0
TWN-1W	TWN1W-s20	—	128	—	c1	0	48	0	48
TWN-1W	TWN1W-s21	—	147	—	c1	10	23	10	10
TWN-1W	TWN1W-s22	TW-26476	147	S	c2	41	54	0	0
TWN-1W	TWN1W-s23	—	158	S	f1? (c2?)	18	0	0	0
TWN-1W	TWN1W-s24	TW-26477	172	—	c1	0	30	0	10
TWN-1W	TWN1W-s25	TW-26478	174	S	c2	22	77	0	0
TWN-1W	TWN1W-s26	—	177	—	c1? (c1b?)	15	33	0	0
TWN-1W	TWN1W-s27	—	180	S	f1	12	0	0	0
TWN-1W	TWN1W-s28	—	190	N	c2	14	16	0	0
TWN-1W	TWN1W-s29	—	192	—	c1	22	18	10	3
TWSE-1E	TWSE1E-s1	—	3	N	f1	24	0	0	0
TWSE-1E	TWSE1E-s2	—	10	N	c2	39	36	0	0
TWSE-1E	TWSE1E-s3	TW-24938	12	N	c1b	38	0	30	0

Table B-1.0-2 (continued)

Reach	Stratigraphic Description Location	Location ID	Reach Distance (m)	Side of Channel	Geomorphic Unit	Fine Facies Thickness (cm)	Coarse Facies Thickness (cm)	Inferred Post-Fire Fine Facies Thickness (cm) ^a	Inferred Post-Fire Coarse Facies Thickness (cm) ^a
TWSE-1E	TWSE1E-s4	TW-24939	15	N	c2	34	26	0	0
TWSE-1E	TWSE1E-s5	—	18	—	c1	0	20	0	0
TWSE-1E	TWSE1E-s6	—	28	N	c2	11	49	11	0
TWSE-1E	TWSE1E-s7	—	38	—	c1	0	50	0	0
TWSE-1E	TWSE1E-s8	—	42	S	c3	9	91	0	0
TWSE-1E	TWSE1E-s9	TW-24941	44	N	c3	9	121	0	0
TWSE-1E	TWSE1E-s10	TW-24942	57	S	f1	18	5	0	0
TWSE-1E	TWSE1E-s11	TW-24943	60	—	c1	0	50	0	0
TWSE-1E	TWSE1E-s12	—	62	S	c3? (c2?)	26	81	0	0
TWSE-1E	TWSE1E-s13	—	74	N	c1b	10	32	0	0
TWSE-1E	TWSE1E-s14	—	76	N	f1	15	10	0	0
TWSE-1E	TWSE1E-s15	—	80	N	c3	41	55	0	0
TWSE-1E	TWSE1E-s16	—	80	—	c1	0	24	0	0
TWSE-1E	TWSE1E-s17	—	85	N	f1	39	0	0	0
TWSE-1E	TWSE1E-s18	TW-10015	91	N	c2	38	12	9	0
TWSE-1E	TWSE1E-s19	—	100	—	c1	0	4	0	0
TWSE-1E	TWSE1E-s20	—	104	N	f1? (c3?)	31	0	0	0
TWSE-1E	TWSE1E-s21	—	114	N	f1	6	0	0	0
TWSE-1E	TWSE1E-s22	TW-10014	123	N	c3	25	22	0	0
TWSE-1E	TWSE1E-s23	TW-24944	123	S	f1	25	0	0	0
TWSE-1E	TWSE1E-s24	—	124	S	c2	6	36	0	0
TWSE-1E	TWSE1E-s25	—	134	—	c1	0	23	0	0
TWSE-1E	TWSE1E-s26	—	144	S	c2	15	31	0	0
TWSE-1E	TWSE1E-s27	TW-10013	148	N	f1	34	0	0	0

Table B-1.0-2 (continued)

Reach	Stratigraphic Description Location	Location ID	Reach Distance (m)	Side of Channel	Geomorphic Unit	Fine Facies Thickness (cm)	Coarse Facies Thickness (cm)	Inferred Post-Fire Fine Facies Thickness (cm) ^a	Inferred Post-Fire Coarse Facies Thickness (cm) ^a
TWSE-1E	TWSE1E-s28	—	150	N	c2 channel	20	19	0	0
TWSE-1E	TWSE1E-s29	—	173	S	f2? (Qt?)	6	0	0	0
TWSE-1E	TWSE1E-s30	—	172	N	c2	36	15	0	0
TWSE-1E	TWSE1E-s31	—	172	—	c1	0	22	0	0
TWSE-1E	TWSE1E-s32	TW-10012	186	N	c2	17	45	3	34
TWSE-1E	TWSE1E-s33	—	190	—	c1	41	39	12	33
TWSE-1E	TWSE1E-s34	—	197	S	c2	33	26	19	16
TWSE-1W	TWSE1W-s1	—	7	S	c2	50	19	0	0
TWSE-1W	TWSE1W-s2	TW-26521	9	S	f1	27	0	0	0
TWSE-1W	TWSE1W-s3	—	10	—	c1	38	12	0	0
TWSE-1W	TWSE1W-s4	TW-26522	17	N	c2	51	15	0	0
TWSE-1W	TWSE1W-s5	—	28	S	c2	54	9	0	0
TWSE-1W	TWSE1W-s6	—	28	N	f1	20	0	0	0
TWSE-1W	TWSE1W-s7	—	32	—	c1	18	4	0	0
TWSE-1W	TWSE1W-s8	TW-26523	38	S	c2	66	0	0	0
TWSE-1W	TWSE1W-s9	—	43	S	f1	18	0	0	0
TWSE-1W	TWSE1W-s10	TW-26524	53	N	c2	43	8	0	0
TWSE-1W	TWSE1W-s11	—	54	N	f1	10	0	0	0
TWSE-1W	TWSE1W-s12	—	62	—	c1	33	6	0	0
TWSE-1W	TWSE1W-s13	—	63	—	c2	42	4	0	0
TWSE-1W	TWSE1W-s14	—	73	S	f1	23	0	0	0
TWSE-1W	TWSE1W-s15	—	86	N	f1	22	0	0	0
TWSE-1W	TWSE1W-s16	TW-26525	87	—	c2	52	14	0	0
TWSE-1W	TWSE1W-s17	TW-26527	87	S	f1	29	0	0	0

Table B-1.0-2 (continued)

Reach	Stratigraphic Description Location	Location ID	Reach Distance (m)	Side of Channel	Geomorphic Unit	Fine Facies Thickness (cm)	Coarse Facies Thickness (cm)	Inferred Post-Fire Fine Facies Thickness (cm) ^a	Inferred Post-Fire Coarse Facies Thickness (cm) ^a
TWSE-1W	TWSE1W-s18	TW-26528	108	S	f1	61	0	0	0
TWSE-1W	TWSE1W-s19	—	116	S	c2	13	7	0	0
TWSE-1W	TWSE1W-s20	—	118	N	f1	17	0	0	0
TWSE-1W	TWSE1W-s21	—	128	—	c2	27	10	0	0
TWSE-1W	TWSE1W-s22	—	132	N	f1	6	0	0	0
TWSE-1W	TWSE1W-s23	—	138	—	c1	10	10	0	0
TWSE-1W	TWSE1W-s24	—	141	S	f1	24	5	0	0
TWSE-1W	TWSE1W-s25	—	160	N	f1	16	0	0	0
TWSE-1W	TWSE1W-s26	—	167	S	f1	10	0	0	0
TWSE-1W	TWSE1W-s27	—	172	—	c1	0	8	0	0
TWSE-1W	TWSE1W-s28	—	180	S	f1	9	0	0	0
TWSE-1W	TWSE1W-s29	TW-26530	181	—	c1	14	20	0	0
TWSE-1W	TWSE1W-s30	—	189	S	c2	16	1	0	0
TWSW-1E	TWSW1E-s1	TW-10000	195	S	f1	20	0	0	0
TWSW-1E	TWSW1E-s2	—	194	N	f1	18	0	0	0
TWSW-1E	TWSW1E-s3	—	188	S	f1	15	0	0	0
TWSW-1E	TWSW1E-s4	—	187	—	c1	0	2	0	2
TWSW-1E	TWSW1E-s5	TW-24936	181	S	c2	48	30	34	8
TWSW-1E	TWSW1E-s6	TW-24937	181	N	c2	24	20	0	6
TWSW-1E	TWSW1E-s7	—	175	S	f1	35	5	10	0
TWSW-1E	TWSW1E-s8	—	173	N	f1	37	5	12	0
TWSW-1E	TWSW1E-s9	TW-24935	165	—	c1	0	20	0	20
TWSW-1E	TWSW1E-s10	TW-10001	157	N	c2	36	47	6	6
TWSW-1E	TWSW1E-s11	—	156	S	c2	17	67	0	48

Table B-1.0-2 (continued)

Reach	Stratigraphic Description Location	Location ID	Reach Distance (m)	Side of Channel	Geomorphic Unit	Fine Facies Thickness (cm)	Coarse Facies Thickness (cm)	Inferred Post-Fire Fine Facies Thickness (cm) ^a	Inferred Post-Fire Coarse Facies Thickness (cm) ^a
TWSW-1E	TWSW1E-s12	TW-10002	144	N	f1	47	0	0	0
TWSW-1E	TWSW1E-s13	—	139	S	f1	30	0	0	0
TWSW-1E	TWSW1E-s14	—	143	—	c1	10	5	10	5
TWSW-1E	TWSW1E-s15	—	125	S	f1	30	0	0	0
TWSW-1E	TWSW1E-s16	—	122	S	f1	26	0	0	0
TWSW-1E	TWSW1E-s17	—	125	S	c2	26	5	8	7
TWSW-1E	TWSW1E-s18	—	115	—	c1	13	34	0	6
TWSW-1E	TWSW1E-s19	—	108	S	f2? (Qt?)	7	0	0	0
TWSW-1E	TWSW1E-s20	—	105	S	f1	6	0	0	0
TWSW-1E	TWSW1E-s21	—	113	N	c2	13	5	10	5
TWSW-1E	TWSW1E-s22	—	92	S	f1	13	0	0	0
TWSW-1E	TWSW1E-s23	TW-10004	88	S	c2	17	26	19	11
TWSW-1E	TWSW1E-s24	TW-24933	86	N	c2	41	0	24	0
TWSW-1E	TWSW1E-s25	—	85	—	c1	0	21	0	21
TWSW-1E	TWSW1E-s26	—	76	N	c2	19	42	5	29
TWSW-1E	TWSW1E-s27	—	67	S	f1	28	0	0	0
TWSW-1E	TWSW1E-s28	—	62	S	c2	16	35	0	24
TWSW-1E	TWSW1E-s29	—	59	—	c1	13	8	1	8
TWSW-1E	TWSW1E-s30	TW-24932	48	S	c2	25	22	5	5
TWSW-1E	TWSW1E-s31	—	40	N	f1	28	0	0	0
TWSW-1E	TWSW1E-s32	—	33	—	c1	0	61	0	4
TWSW-1E	TWSW1E-s33	—	27	S	c2	47	9	23	9
TWSW-1E	TWSW1E-s34	—	16	N	c2	64	6	7	0
TWSW-1E	TWSW1E-s35	—	12	—	c1	0	1	0	1

Table B-1.0-2 (continued)

Reach	Stratigraphic Description Location	Location ID	Reach Distance (m)	Side of Channel	Geomorphic Unit	Fine Facies Thickness (cm)	Coarse Facies Thickness (cm)	Inferred Post-Fire Fine Facies Thickness (cm) ^a	Inferred Post-Fire Coarse Facies Thickness (cm) ^a
TWSW-1E	TWSW1E-s36	—	8	N	c2	39	9	15	9
TWSW-1W	TWSW1W-s1	—	1	—	c2	69	13	6	0
TWSW-1W	TWSW1W-s2	—	7	N	f1	9	0	0	0
TWSW-1W	TWSW1W-s3	—	7	S	f1	15	0	0	0
TWSW-1W	TWSW1W-s4	TW-26531	15	—	c2	24	22	6	0
TWSW-1W	TWSW1W-s5	—	26	S	f1	7	0	0	0
TWSW-1W	TWSW1W-s6	—	27	S	c2	16	9	0	0
TWSW-1W	TWSW1W-s7	—	32	—	c1	4	28	0	10
TWSW-1W	TWSW1W-s8	—	41	S	c2	62	10	0	0
TWSW-1W	TWSW1W-s9	—	43	S	f2	2	0	0	0
TWSW-1W	TWSW1W-s10	TW-26532	49	S	c2	53	7	0	0
TWSW-1W	TWSW1W-s11	TW-26533	54	—	c1	17	5	17	5
TWSW-1W	TWSW1W-s12	—	56	S	f1	9	0	3	0
TWSW-1W	TWSW1W-s13	—	63	N	f1	12	0	0	0
TWSW-1W	TWSW1W-s14	—	64	N	c2	20	4	0	0
TWSW-1W	TWSW1W-s15	TW-26534	68	S	f1? (c2?)	42	28	0	0
TWSW-1W	TWSW1W-s16	—	68	N	f1	12	0	0	0
TWSW-1W	TWSW1W-s17	—	71	S	f1	19	0	6	0
TWSW-1W	TWSW1W-s18	—	72	—	c1	0	8	0	8
TWSW-1W	TWSW1W-s19	—	73	N	f1	14	0	4	0
TWSW-1W	TWSW1W-s20	—	80	S	f1? (c2?)	7	0	3	0
TWSW-1W	TWSW1W-s21	—	81	N	c2	14	15	0	0
TWSW-1W	TWSW1W-s22	—	84	N	f1	7	0	0	0
TWSW-1W	TWSW1W-s23	—	87	N	c2 swale	12	0	0	0

Table B-1.0-2 (continued)

Reach	Stratigraphic Description Location	Location ID	Reach Distance (m)	Side of Channel	Geomorphic Unit	Fine Facies Thickness (cm)	Coarse Facies Thickness (cm)	Inferred Post-Fire Fine Facies Thickness (cm) ^a	Inferred Post-Fire Coarse Facies Thickness (cm) ^a
TWSW-1W	TWSW1W-s24	—	88	—	c1	25	9	25	9
TWSW-1W	TWSW1W-s25	—	90	S	f1	10	0	3	0
TWSW-1W	TWSW1W-s26	TW-26535	92	S	f1	21	0	0	0
TWSW-1W	TWSW1W-s27	TW-26536	102	S	c2	34	0	9	0
TWSW-1W	TWSW1W-s28	—	105	S	f1 swale	16	0	3	0
TWSW-1W	TWSW1W-s29	—	110	N	c2	12	0	4	0
TWSW-1W	TWSW1W-s30	—	113	S	f1	23	0	6	0
TWSW-1W	TWSW1W-s31	—	111	—	c1	0	17	0	17
TWSW-1W	TWSW1W-s32	—	125	S	f1	15	0	0	0
TWSW-1W	TWSW1W-s33	TW-26537	126	N	c2	18	30	15	0
TWSW-1W	TWSW1W-s34	TW-26538	132	N	f1	41	0	0	0
TWSW-1W	TWSW1W-s35	TW-26539	136	S	f1	22	0	0	0
TWSW-1W	TWSW1W-s36	—	140	N	f1	24	0	0	0
TWSW-1W	TWSW1W-s37	—	146	—	c1	0	13	0	13
TWSW-1W	TWSW1W-s38	—	148	S	f1	26	0	0	0
TWSW-1W	TWSW1W-s39	—	150	S	f1 swale	9	0	3	0
TWSW-1W	TWSW1W-s40	—	168	S	f1	14	0	0	0
TWSW-1W	TWSW1W-s41	—	173	—	c1	45	0	28	0
TWSW-1W	TWSW1W-s42	TW-26540	176	S	c2	28	0	0	0
TWSW-1W	TWSW1W-s43	—	191	S	c2	19	0	0	0
TWSW-1W	TWSW1W-s44	—	192	—	c1	4	3	4	3
TWSW-1W	TWSW1W-s45	—	195	N	f1	15	0	0	0

^a Applies to reaches with significant effects from Cerro Grande fire with recognizable post-fire deposits; may not be complete.

^b — Indicates not applicable (no relation to channel, no fixed point or stratigraphic location, or no location ID).

Table B-1.0-3
Particle Size, Organic Matter, and pH Data from Sediment Investigation Reaches

Reach	Sample ID	Unit	Facies	Gravel (> 2 mm) (wt %)	Very Coarse Sand (2-1 mm) (wt %)	Coarse Sand (1-0.5 mm) (wt %)	Medium Sand (0.5-0.25 mm) (wt%)	Fine Sand (0.25-0.125 mm) (wt %)	Very Fine Sand (0.125-0.0625 mm) (wt %)	Coarse Silt (62.5-15 µm) (wt%)	Fine Silt (15-2 µm) (wt%)	Clay (<2 µm) (wt%)	Median Particle Size Class ^a	Total Silt + Clay (wt%)	Organic Matter (wt %)	pH
AEN-1	CAPA-05-61651	c2	coarse	55.8	38.3	15.4	9.0	4.4	4.6	11.3	9.0	8.1	cs	28.4	2.08	5.57
AEN-1	CAPA-05-61652	c2	fine	1.2	5.6	13.3	11.2	7.1	8.1	24.4	14.1	16.3	csi	54.9	5.91	5.38
AEN-1	CAPA-05-61653	f2	fine	3.0	6.0	9.8	9.8	8.0	17.0	33.3	6.6	9.4	vfs	49.3	2.06	6.43
AEN-1	CAPA-05-61654	c2	fine	0.9	1.5	4.7	6.4	7.6	20.7	41.8	7.8	9.5	csi	59.1	1.94	5.06
AEN-1	CAPA-05-61655	c2	fine	4.9	6.3	12.0	9.7	6.5	11.8	35.0	9.7	9.1	csi	53.8	2.82	4.98
AEN-1	CAPA-05-61656	c1	coarse	59.2	55.2	23.5	7.6	3.4	1.9	2.4	2.6	3.4	vcs	8.4	1.02	6.33
AEN-1	CAPA-05-61657	f1	fine	0.1	0.8	2.6	4.4	5.2	8.1	30.7	24.5	23.8	csi	79.0	6.53	4.74
AEN-1	CAPA-05-61658	f1	fine	0.0	0.2	1.1	1.0	1.7	15.2	56.9	12.1	11.8	csi	80.9	3.09	5.34
AEN-1	CAPA-05-61659	f1	fine	2.3	5.0	11.7	10.3	7.2	14.5	29.7	10.7	10.9	csi	51.2	3.15	5.36
AEN-1	CAPA-05-61660	c2	fine	14.0	11.6	17.4	11.9	6.9	7.0	18.8	12.1	14.4	vfs	45.3	4.14	6.10
AEN-1	CAPA-08-8446	f1	fine	0.6	0.2	4.1	9.4	7.9	9.8	32.4	18.0	18.0	csi	68.3	4.38	4.93
AES-1	CAPA-05-61641	c2	fine	8.7	3.8	10.2	10.9	8.6	15.1	30.3	9.8	11.2	csi	51.2	2.84	5.67
AES-1	CAPA-05-61642	c2	fine	0.1	1.3	3.6	3.8	4.0	11.9	46.1	13.0	16.2	csi	75.4	2.57	5.48
AES-1	CAPA-05-61643	c2	fine	2.4	5.1	9.0	7.4	5.5	9.9	31.1	15.4	16.5	csi	63.0	3.08	5.08
AES-1	CAPA-05-61644	c2	coarse	53.7	48.7	27.2	6.2	1.4	1.0	2.1	4.6	8.7	cs	15.4	1.13	5.36
AES-1	CAPA-05-61645	f1	fine	0.0	0.0	0.2	1.4	3.7	20.2	50.2	7.8	16.3	csi	74.3	2.18	5.57
AES-1	CAPA-05-61646	f1	fine	0.0	0.0	0.5	1.3	3.2	16.8	51.9	11.4	14.9	csi	78.2	2.46	5.08
AES-1	CAPA-05-61647	f1	fine	0.2	0.9	2.1	1.9	1.9	8.3	44.4	19.9	20.5	csi	84.8	1.92	5.60
AES-1	CAPA-05-61648	c1	coarse	54.8	50.5	25.5	7.1	1.7	1.4	4.5	4.4	4.9	vcs	13.9	0.68	5.76
AES-1	CAPA-05-61649	c2	fine	0.6	0.9	2.2	2.6	4.1	17.0	47.3	11.3	14.7	csi	73.3	1.95	5.15
AES-1	CAPA-05-61650	c2	fine	0.0	1.5	5.0	6.9	4.8	9.1	34.1	19.6	19.0	csi	72.7	3.97	5.81
AW-1	CAPA-06-70616	c1w	fine	0.2	0.1	0.4	0.7	2.5	7.4	23.6	29.1	36.0	fsi	88.7	3.74	6.38
AW-1	CAPA-06-70617	c1w	fine	45.9	1.2	3.2	3.1	2.7	5.5	27.3	25.7	31.2	fsi	84.2	2.92	5.71
AW-1	CAPA-06-70618	c2	fine	1.1	0.4	1.6	2.5	5.1	16.7	41.9	13.4	18.3	csi	73.6	3.42	5.96
AW-1	CAPA-06-70619	c2	fine	0.6	0.2	1.1	1.5	2.0	6.0	40.8	24.5	23.8	csi	89.1	5	5.10
AW-1	CAPA-06-70620	c2	fine	8.0	0.3	0.9	1.1	1.1	4.0	37.1	29.9	25.5	fsi	92.5	4.06	5.52
AW-1	CAPA-06-70621	c2	fine	5.5	2.8	8.5	7.5	5.0	8.3	28.1	19.7	20.0	csi	67.9	2.98	5.45
AW-1	CAPA-06-70622	c1	coarse	34.9	29.8	32.2	13.5	3.0	1.7	4.4	6.1	9.2	cs	19.7	0.96	5.52
AW-1	CAPA-06-70623	c2	fine	6.1	2.7	4.5	4.3	4.0	8.6	36.0	17.3	22.6	csi	75.9	2.53	5.13
AW-1	CAPA-06-70624	c2	fine	17.8	7.7	10.2	6.6	4.2	7.7	24.8	18.4	20.4	csi	63.5	4.10	5.17
AW-1	CAPA-06-70625	c2	coarse	0.7	26.8	27.4	10.2	3.2	3.4	8.9	7.4	12.6	cs	28.9	1.40	5.22
AW-1	CAPA-07-4736	c1f	coarse	52.7	25.0	17.0	12.4	7.6	6.2	13.4	8.1	10.4	ms	31.8	— ^b	6.19
AW-1	CAPA-07-4737	c2	fine	0.0	0.6	3.5	3.6	2.9	5.7	34.1	27.0	22.4	csi	83.6	—	5.70
AW-1	CAPA-07-4738	c2	fine	0.1	0.4	2.1	1.9	2.6	6.6	36.9	26.4	23.1	csi	86.4	—	5.82
AW-1	CAPA-07-4739	c2	fine	1.3	3.2	5.8	4.9	5.3	12.5	38.2	15.8	14.3	csi	68.3	—	5.41
AW-1	CAPA-07-4740	c2	fine	3.0	2.0	5.1	6.1	7.2	14.6	37.1	13.8	13.9	csi	64.8	—	5.36

Table B-1.0-3 (continued)

Reach	Sample ID	Unit	Facies	Gravel (> 2 mm) (wt %)	Very Coarse Sand (2-1 mm) (wt %)	Coarse Sand (1-0.5 mm) (wt %)	Medium Sand (0.5-0.25 mm) (wt%)	Fine Sand (0.25-0.125 mm) (wt %)	Very Fine Sand (0.125-0.0625 mm) (wt %)	Coarse Silt (62.5-15 µm) (wt%)	Fine Silt (15-2 µm) (wt%)	Clay (<2 µm) (wt%)	Median Particle Size Class ^a	Total Silt + Clay (wt%)	Organic Matter (wt %)	pH
AW-1	CAPA-07-4741	c2	fine	5.8	2.5	6.0	4.5	4.1	11.6	38.8	14.9	17.5	csi	71.2	—	5.27
AW-1	CAPA-07-4742	c1	fine	0.9	0.2	2.2	2.4	1.5	3.1	28.8	33.8	28.1	fsi	90.6	—	5.47
AW-1	CAPA-07-4743	c2	fine	0.5	1.1	3.9	2.6	1.3	2.3	21.6	37.1	30.0	fsi	88.8	—	5.54
AW-1	CAPA-07-4744	c2	coarse	18.3	24.3	22.5	10.2	3.7	3.7	11.1	13.0	11.6	ms	35.7	—	5.57
AW-1	CAPA-07-4745	c2	fine	0.3	1.6	5.3	6.2	6.0	13.9	37.5	12.7	16.9	csi	67.0	—	5.66
AW-1	CAPA-08-8447	c2	fine	1.8	4.7	7.7	4.9	4.4	9.4	35.2	15.3	18.3	csi	68.8	3.55	6.08
AW-1	CAPA-08-8452	c1	coarse	15.6	32.4	28.0	8.4	2.9	2.9	8.8	7.6	8.9	cs	25.2	1.76	4.75
PA-0	CAPA-06-71046	c2+f1	fine	2.7	2.3	7.2	10.1	11.1	12.1	27.9	16.6	12.8	csi	57.4	3.34	5.61
PA-0	CAPA-06-71047	c2	coarse	49.9	15.8	18.4	20.2	13.8	9.7	11.6	5.2	5.7	ms	22.5	1.91	7.05
PA-0	CAPA-06-71048	c1	coarse	57.8	43.1	28.0	11.5	3.4	1.6	2.7	4.8	5.1	cs	12.6	0.96	6.78
PA-0	CAPA-06-71049	f1	fine	2.5	0.5	6.0	14.7	15.9	15.5	29.1	10.2	8.2	vfs	47.5	2.82	7.33
PA-0	CAPA-06-71050	c2+f1	fine	12.3	7.6	10.2	9.9	9.2	11.0	26.8	12.7	12.7	csi	52.3	3.33	6.59
PA-0	CAPA-06-71051	c2	fine	1.8	11.2	19.4	14.7	8.2	6.7	16.6	12.2	11.2	fs	40.0	2.09	5.82
PA-0	CAPA-06-71052	f1	fine	16.9	7.1	15.8	17.6	12.4	10.1	19.0	9.1	9.1	fs	37.2	3.28	7.17
PA-0	CAPA-06-71053	f1	fine	1.2	4.0	20.5	28.0	16.5	7.6	11.3	6.0	6.4	ms	23.6	1.64	7.38
PA-0	CAPA-06-71054	c2+f1	coarse	68.7	25.2	19.6	12.9	7.6	6.3	16.9	6.6	5.0	ms	28.5	2.78	7.45
PA-0	CAPA-06-71055	c2+f1	coarse	0.0	21.7	21.2	16.4	9.0	6.6	11.7	7.0	6.6	ms	25.2	2.05	6.95
PA-0	CAPA-08-8448	f1	fine	23.5	4.0	11.8	15.0	11.5	9.6	26.3	13.3	8.5	vfs	48.2	2.53	6.75
PA-0	CAPA-08-8453	c1	coarse	67.4	24.0	22.9	14.0	5.7	4.4	11.1	10.5	7.1	ms	28.7	1.44	6.47
PA-1E	CAPA-06-71127	f1? (c3?)	fine	0.6	13.1	31.9	20.9	10.0	6.9	9.6	3.7	4.0	ms	17.2	1.3	6.57
PA-1E	CAPA-06-71128	c2	coarse	35.9	33.4	30.0	13.4	4.2	3.3	6.4	3.7	5.4	cs	15.5	1.2	6.31
PA-1E	CAPA-06-71129	c1	coarse	44.0	55.1	28.9	9.6	1.9	0.8	0.7	1.2	1.6	vcs	3.6	0.4	6.46
PA-1E	CAPA-06-71130	c2? (f1?)	fine	1.3	3.4	8.9	17.3	20.6	14.1	20.9	7.1	7.6	fs	35.6	2.5	6.43
PA-1E	CAPA-06-71131	c2? (f1?)	coarse	37.8	53.5	21.6	7.2	3.7	2.6	4.8	3.5	3.1	vcs	11.4	1.0	6.75
PA-1E	CAPA-06-71132	c1	coarse	49.9	64.8	24.7	5.2	1.2	0.6	0.3	1.4	1.5	vcs	3.3	0.4	6.70
PA-1E	CAPA-06-71133	c2	fine	1.1	7.6	17.4	16.0	11.7	11.9	21.1	7.5	6.7	fs	35.2	2.4	6.86
PA-1E	CAPA-06-71134	c2	fine	1.3	4.2	16.7	12.3	8.3	9.5	25.6	11.7	11.8	vfs	49.1	3.6	5.83
PA-1E	CAPA-06-71135	f1? (c3?)	fine	0.3	4.0	9.6	10.7	12.0	21.5	28.0	6.3	8.0	vfs	42.2	1.8	6.52
PA-1E	CAPA-06-71136	f1	fine	2.3	2.4	7.3	11.2	11.8	20.2	31.1	6.8	9.2	vfs	47.0	2.1	6.70
PA-1E	CAPA-08-8449	c2	fine	1.4	2.3	11.1	14.7	11.0	11.8	27.8	10.8	10.6	vfs	49.2	3.05	6.33
PA-1W	CAPA-06-71063	c1	coarse	47.8	46.3	35.0	12.6	2.2	0.5	-0.1	1.3	2.1	cs	3.4	0.36	6.90
PA-1W	CAPA-06-71064	c2	fine	5.0	1.8	4.3	7.1	9.2	16.2	36.8	11.6	13.1	csi	61.5	2.57	6.29
PA-1W	CAPA-06-71065	c2	coarse	91.4	17.3	21.8	23.8	11.3	5.8	8.6	5.6	5.6	ms	19.8	1.26	6.52
PA-1W	CAPA-06-71066	c2	fine	0.4	1.8	5.6	9.0	10.6	16.1	34.9	10.2	11.7	csi	56.9	3.02	6.10
PA-1W	CAPA-06-71067	f1? (c3?)	fine	0.2	0.0	0.3	0.8	1.8	8.4	46.8	25.5	16.4	csi	88.6	3.80	6.00
PA-1W	CAPA-06-71068	f1	fine	3.9	9.6	22.4	26.9	14.2	9.4	10.9	3.5	3.2	ms	17.5	0.89	6.33

Table B-1.0-3 (continued)

Reach	Sample ID	Unit	Facies	Gravel (> 2 mm) (wt %)	Very Coarse Sand (2-1 mm) (wt %)	Coarse Sand (1-0.5 mm) (wt %)	Medium Sand (0.5-0.25 mm) (wt%)	Fine Sand (0.25-0.125 mm) (wt %)	Very Fine Sand (0.125-0.0625 mm) (wt %)	Coarse Silt (62.5-15 µm) (wt%)	Fine Silt (15-2 µm) (wt%)	Clay (<2 µm) (wt%)	Median Particle Size Class ^a	Total Silt + Clay (wt%)	Organic Matter (wt %)	pH
PA-1W	CAPA-06-71069	c1	coarse	79.7	35.2	22.2	18.6	10.7	4.2	3.7	2.1	3.1	cs	8.9	0.73	6.55
PA-1W	CAPA-06-71070	f1? (c3?)	fine	2.0	3.5	7.6	8.7	9.7	15.1	36.0	8.6	11.0	csi	55.6	2.67	6.22
PA-1W	CAPA-06-71071	c2	fine	9.4	11.6	18.7	20.5	13.8	9.3	13.8	6.3	6.0	ms	26.0	2.24	6.50
PA-1W	CAPA-06-71072	c2	fine	8.9	5.2	9.8	13.3	11.7	13.7	26.2	9.9	10.2	vfs	46.3	3.33	6.57
PA-2W	CAPA-05-62706	c2	fine	0.5	4.1	8.7	7.4	7.0	8.2	31.0	18.4	14.9	csi	64.4	4.05	6.02
PA-2W	CAPA-05-62707	f2	fine	0.1	0.0	0.9	2.3	2.2	4.2	46.6	22.6	21.2	csi	90.3	3.14	6.14
PA-2W	CAPA-05-62708	f1	fine	3.0	6.9	13.2	17.9	11.5	12.8	22.7	7.0	7.9	vfs	37.6	1.82	5.82
PA-2W	CAPA-05-62709	c2	coarse	30.4	28.3	35.4	13.6	2.9	1.6	2.9	5.9	9.2	cs	18.0	1.04	5.75
PA-2W	CAPA-05-62710	f1	fine	0.1	0.4	2.6	6.2	10.2	20.5	39.4	7.9	12.9	csi	60.2	2.30	6.07
PA-2W	CAPA-05-62711	f1	fine	0.8	2.6	9.6	17.9	13.6	14.4	23.9	8.4	9.4	vfs	41.8	1.62	5.49
PA-2W	CAPA-05-62712	c2	fine	1.6	0.4	2.9	5.8	16.3	21.9	29.7	10.7	12.2	csi	52.6	4.24	5.73
PA-2W	CAPA-05-62713	c1	coarse	20.0	54.3	29.3	7.6	1.5	0.7	0.6	2.1	3.8	vcs	6.4	0.64	6.28
PA-2W	CAPA-05-62725	c2	fine	3.1	12.7	16.4	7.8	3.8	3.4	18.4	18.2	19.2	csi	55.9	4.34	5.76
PA-2W	CAPA-05-62726	c2	fine	7.4	11.3	20.8	13.5	6.3	5.3	14.6	12.4	15.7	fs	42.7	3.76	5.64
PA-2W	CAPA-06-71059	f2	fine	0.0	0.0	0.2	0.6	3.2	14.9	55.2	13.3	12.7	csi	81.1	4.2	6.29
PA-2W	CAPA-06-71060	c1	coarse	15.5	49.4	32.2	10.2	2.4	1.0	1.2	1.7	1.9	cs	4.8	0.4	6.26
PA-2W	CAPA-07-4751	f2	fine	0.0	0.0	0.7	1.1	4.6	18.3	49.5	15.3	10.3	csi	75.2	99.9	NA
PA-2W	CAPA-07-4752	f1 swale	fine	0.1	0.0	1.0	1.9	9.5	20.9	43.9	13.3	9.3	csi	66.6	99.9	NA
PA-3E	CAPA-05-62715	f1	fine	2.8	4.4	11.5	11.3	8.2	11.4	32.2	10.2	10.8	csi	53.3	2.43	6.22
PA-3E	CAPA-05-62716	c2	fine	0.0	0.3	1.7	4.2	8.9	17.9	43.1	14.0	9.9	csi	67.0	1.74	6.63
PA-3E	CAPA-05-62717	f2	fine	0.3	0.2	1.3	4.8	10.1	17.5	41.9	11.8	12.6	csi	66.3	2.37	6.23
PA-3E	CAPA-05-62718	c2	fine	0.1	0.3	0.9	2.1	3.8	10.0	56.0	16.7	10.1	csi	82.8	1.76	6.66
PA-3E	CAPA-05-62719	c2	fine	0.0	1.6	3.4	6.5	8.9	14.0	43.5	13.1	9.0	csi	65.6	1.54	6.51
PA-3E	CAPA-05-62720	c1	coarse	18.5	49.1	39.4	9.1	0.9	0.3	0.0	0.2	1.0	cs	1.2	0.13	6.49
PA-3E	CAPA-05-62721	c2	fine	0.1	0.2	1.0	2.4	5.1	10.1	46.9	21.7	12.8	csi	81.3	4.18	7.00
PA-3E	CAPA-05-62722	c2	coarse	26.4	34.0	29.7	19.0	6.2	1.9	3.0	2.2	3.9	cs	9.1	0.43	6.78
PA-3E	CAPA-05-62723	f1w	fine	0.0	0.0	0.6	1.7	2.4	6.5	44.4	28.2	16.2	csi	88.8	5.23	7.00
PA-3E	CAPA-05-62724	f1w	fine	0.1	0.0	0.7	1.6	2.0	6.0	43.9	28.9	16.8	csi	89.6	5.84	7.14
PA-3E	CAPA-07-4753	f1w	fine	0.3	0.1	0.9	1.4	4.8	13.4	46.3	21.8	11.3	csi	79.5	100.0	NA
PA-3E	CAPA-07-4756	c2	fine	2.2	3.5	15.7	35.4	18.7	7.6	9.1	4.9	5.2	ms	19.2	100.0	NA
PA-4	CAPA-04-53801	c2	coarse	22.5	23.1	33.9	23.0	4.4	1.2	3.3	3.6	7.3	cs	14.3	1.3	6.11
PA-4	CAPA-04-53802	c1w	fine	0.0	0.1	0.3	0.5	0.6	0.6	9.1	49.4	39.4	fsi	97.9	12.4	6.22
PA-4	CAPA-04-53803	c1w	fine	0.1	0.6	1.7	1.3	3.4	8.1	36.4	26.1	22.1	csi	84.6	4.9	5.85
PA-4	CAPA-04-53804	c1w	coarse	8.0	48.4	40.4	4.1	0.5	1.0	2.0	1.6	2.0	cs	5.5	0.5	5.80
PA-4	CAPA-04-53805	c1w	fine	0.1	0.3	0.5	0.4	1.2	12.2	61.0	11.3	13.1	csi	85.4	3.0	5.73
PA-4	CAPA-04-53806	c1w	fine	2.5	4.8	3.4	3.9	14.6	16.0	35.2	10.7	11.4	csi	57.3	13.2	6.25
PA-4	CAPA-04-53807	c1w	fine	0.0	0.1	0.4	0.8	1.6	4.0	49.9	25.8	17.3	csi	93.0	3.0	6.35

Table B-1.0-3 (continued)

Reach	Sample ID	Unit	Facies	Gravel (> 2 mm) (wt %)	Very Coarse Sand (2-1 mm) (wt %)	Coarse Sand (1-0.5 mm) (wt %)	Medium Sand (0.5-0.25 mm) (wt%)	Fine Sand (0.25-0.125 mm) (wt %)	Very Fine Sand (0.125-0.0625 mm) (wt %)	Coarse Silt (62.5-15 µm) (wt%)	Fine Silt (15-2 µm) (wt%)	Clay (<2 µm) (wt%)	Median Particle Size Class ^a	Total Silt + Clay (wt%)	Organic Matter (wt %)	pH
PA-4	CAPA-04-53808	c2	fine	3.9	4.8	13.8	19.4	11.1	6.9	15.9	11.1	16.7	vfs	43.7	4.7	6.60
PA-4	CAPA-04-53809	c1 pool	fine	0.0	0.1	0.5	0.8	0.6	0.6	8.3	55.7	33.4	fsi	97.3	10.3	6.84
PA-4	CAPA-04-53810	c1 pool	fine	5.7	2.3	5.5	5.6	4.6	5.2	19.3	21.3	36.2	fsi	76.8	5.2	6.82
PA-4	CAPA-08-8450	c1 pool	fine	0.2	0.4	1.6	1.4	1.0	1.1	16.8	45.2	32.4	fsi	94.4	2.61	6.04
PA-4	CAPA-08-8454	c1	coarse	41.0	47.8	21.9	6.6	2.0	1.4	5.4	6.0	8.9	cs	20.4	1.66	5.75
PA-5W	CAPA-06-71101	c3	coarse	5.6	24.9	35.5	20.3	7.1	3.6	3.6	1.6	3.2	cs	8.5	0.05	7.12
PA-5W	CAPA-06-71102	c3	fine	0.3	3.8	12.2	18.6	16.5	18.1	22.3	2.6	6.0	fs	30.9	0.91	7.09
PA-5W	CAPA-06-71103	c3? (f1?)	fine	1.1	7.1	17.5	19.5	12.8	13.4	19.0	3.6	7.2	fs	29.8	2.14	7.28
PA-5W	CAPA-06-71104	c3? (f1?)	fine	2.6	6.5	18.8	20.9	15.5	12.2	17.0	3.9	5.3	fs	26.1	1.16	7.29
PA-5W	CAPA-06-71105	c3	coarse	68.5	51.6	24.4	10.0	3.6	2.1	2.7	1.6	3.9	vcs	8.2	0.40	7.28
PA-5W	CAPA-06-71106	f1	fine	0.3	3.2	12.4	17.5	11.1	16.2	22.1	5.7	11.7	vfs	39.5	1.53	7.67
PA-5W	CAPA-06-71107	c1	coarse	28.9	54.9	24.5	4.4	1.1	1.2	3.3	3.7	6.9	vcs	13.9	1.02	7.57
PA-5W	CAPA-06-71108	c1b? (f1 swale?)	fine	0.0	0.7	2.0	1.7	1.1	2.5	24.6	38.7	28.8	fsi	92.2	1.52	7.69
PA-5W	CAPA-06-71109	f1	fine	0.4	3.7	15.7	16.6	11.1	16.4	22.1	4.8	9.5	vfs	36.4	6.33	7.71
PA-5W	CAPA-06-71110	c2	coarse	33.7	32.6	22.1	10.2	4.4	4.8	10.2	5.6	10.2	cs	26.0	1.45	7.62
PAS-1E	CAPA-06-70629	c2	fine	0.3	1.1	5.1	8.7	7.5	15.4	35.1	12.5	14.6	csi	62.3	3.07	5.38
PAS-1E	CAPA-06-70630	c2	fine	0.5	0.4	1.5	3.3	4.1	16.4	43.8	11.9	18.6	csi	74.4	2.45	5.33
PAS-1E	CAPA-06-70631	c2	coarse	61.2	28.3	19.8	9.6	3.9	4.6	11.0	9.3	13.6	ms	33.8	1.53	5.62
PAS-1E	CAPA-06-70632	c2	fine	5.1	3.0	6.4	9.1	8.3	13.1	33.4	12.7	14.0	csi	60.1	2.89	5.59
PAS-1E	CAPA-06-70633	c2	coarse	45.2	42.6	32.6	10.0	1.5	0.9	1.4	3.6	7.3	cs	12.3	0.82	5.69
PAS-1E	CAPA-06-70634	f1	fine	0.1	0.1	0.4	2.9	12.0	23.5	44.6	9.5	6.9	csi	61.0	2.09	6.85
PAS-1E	CAPA-06-70635	c1	coarse	64.3	32.8	32.6	15.0	3.6	1.9	4.0	3.6	6.4	cs	14.0	0.89	5.68
PAS-1E	CAPA-06-70636	c1	coarse	40.9	37.2	34.9	14.1	2.7	1.2	2.6	3.0	4.1	cs	9.7	0.79	5.78
PAS-1E	CAPA-06-70637	c2	fine	0.3	1.1	3.5	5.8	5.8	14.3	42.8	11.2	15.4	csi	69.4	2.30	5.12
PAS-1E	CAPA-06-70638	c2? (f1?)	fine	3.9	0.6	2.0	4.1	6.1	22.0	47.0	7.3	10.8	csi	65.2	2.14	5.27
PAS-1E	CAPA-08-8451	c2	fine	0.4	0.7	2.3	4.2	4.6	15.1	44.6	12.6	15.8	csi	73.0	5.07	4.86
PAS-2E	CAPA-08-8455	c1	coarse	19.0	45.7	33.4	10.7	2.3	1.1	1.4	2.4	2.9	cs	6.7	0.47	6.40
PAS-2W	CAPA-05-61631	c2	fine	0.7	1.1	3.0	6.9	10.6	22.4	33.3	7.4	15.3	csi	56.0	2.49	5.44
PAS-2W	CAPA-05-61632	f1	fine	0.1	0.4	2.1	6.2	7.3	19.0	38.5	10.8	15.7	csi	64.9	2.47	5.61
PAS-2W	CAPA-05-61633	c2	fine	0.3	3.0	9.3	9.5	6.2	11.0	33.3	13.3	14.3	csi	61.0	4.11	5.48
PAS-2W	CAPA-05-61634	c2	coarse	42.8	31.1	31.7	12.4	3.2	2.6	5.3	5.8	7.8	cs	18.9	1.36	5.60
PAS-2W	CAPA-05-61635	c1	coarse	37.3	53.0	25.0	6.7	1.7	1.0	1.1	4.9	6.7	vcs	12.7	1.12	5.61
PAS-2W	CAPA-05-61636	f1	fine	0.1	0.7	3.9	5.9	5.5	20.1	40.2	8.5	15.1	csi	63.9	2.37	5.49
PAS-2W	CAPA-05-61637	f1	fine	0.3	1.3	4.0	7.2	7.7	18.6	36.7	8.1	16.4	csi	61.2	2.65	5.32
PAS-2W	CAPA-05-61638	c2	fine	1.2	1.3	4.5	7.4	8.7	20.1	38.8	4.8	14.5	csi	58.1	2.51	5.44
PAS-2W	CAPA-05-61639	f1	fine	3.3	3.8	7.1	7.9	7.1	15.5	33.5	7.5	17.6	csi	58.7	2.29	5.35
PAS-2W	CAPA-05-61640	f1	fine	0.2	0.4	2.5	7.8	9.3	20.9	41.3	7.1	10.5	csi	59.0	2.69	5.27

Table B-1.0-3 (continued)

Reach	Sample ID	Unit	Facies	Gravel (> 2 mm) (wt %)	Very Coarse Sand (2-1 mm) (wt %)	Coarse Sand (1-0.5 mm) (wt %)	Medium Sand (0.5-0.25 mm) (wt%)	Fine Sand (0.25-0.125 mm) (wt %)	Very Fine Sand (0.125-0.0625 mm) (wt %)	Coarse Silt (62.5-15 µm) (wt%)	Fine Silt (15-2 µm) (wt%)	Clay (<2 µm) (wt%)	Median Particle Size Class ^a	Total Silt + Clay (wt%)	Organic Matter (wt %)	pH
TH-1C	CATH-06-70642	c2	fine	3.4	6.8	6.7	4.0	4.4	9.8	35.4	17.3	15.6	csi	68.4	3.63	5.31
TH-1C	CATH-06-70643	c2	fine	3.8	7.4	10.9	13.9	12.4	9.6	21.1	11.2	13.5	vfs	45.8	2.11	5.18
TH-1C	CATH-06-70644	c2	coarse	12.3	32.0	27.4	17.7	7.6	3.3	5.1	3.0	4.0	cs	12.1	0.56	5.61
TH-1C	CATH-06-70645	c2	coarse	25.2	46.6	22.9	8.1	3.0	2.5	6.4	5.1	5.4	cs	16.9	1.46	5.59
TH-1C	CATH-06-70646	c2	fine	0.6	1.4	6.1	7.6	7.8	14.3	38.0	12.2	12.6	csi	62.8	1.70	4.84
TH-1C	CATH-06-70647	c2	fine	5.7	9.5	11.5	8.8	7.1	7.7	25.3	15.3	14.8	csi	55.3	2.73	5.35
TH-1C	CATH-06-70648	c2	fine	15.7	6.9	10.2	12.3	12.2	11.6	25.0	8.2	13.6	vfs	46.8	1.95	5.23
TH-1C	CATH-06-70649	c2	fine	2.0	9.6	13.8	7.2	5.8	10.4	28.2	10.9	13.6	csi	52.6	1.87	4.39
TH-1C	CATH-06-70650	c2	fine	3.3	5.2	9.7	8.1	7.1	8.3	26.7	16.7	18.2	csi	61.6	3.39	5.98
TH-1C	CATH-06-70651	c1	coarse	5.5	33.1	37.3	12.4	4.1	2.8	4.0	3.3	2.9	cs	10.1	0.99	6.01
TH-1E	CATH-05-62760	c2	fine	3.2	0.7	3.3	6.9	8.0	13.6	35.3	17.9	14.2	csi	67.4	4.33	6.04
TH-1E	CATH-05-62761	c2	fine	4.9	1.5	2.9	2.9	5.0	11.7	39.9	19.1	17.0	csi	76.0	3.07	5.30
TH-1E	CATH-05-62762	c2	coarse	12.3	29.9	24.1	14.5	5.9	3.7	5.4	5.9	10.6	cs	21.9	1.31	5.37
TH-1E	CATH-05-62763	c2	fine	3.0	2.1	4.2	6.1	7.1	10.2	32.6	16.8	20.9	csi	70.2	3.71	5.59
TH-1E	CATH-05-62764	c2	fine	0.4	0.5	1.1	1.0	1.0	3.4	29.5	31.2	32.3	fsi	92.9	3.48	5.20
TH-1E	CATH-05-62765	c1	coarse	29.8	47.7	24.4	7.1	2.4	2.1	5.2	4.0	6.9	cs	16.2	0.51	5.87
TH-1E	CATH-05-62766	f1	fine	0.5	1.2	2.4	5.5	7.5	18.1	42.9	7.3	15.2	csi	65.4	1.47	5.47
TH-1E	CATH-05-62767	c2	fine	0.1	1.0	1.2	0.9	1.9	10.0	48.3	17.4	19.3	csi	85.0	1.71	5.49
TH-1E	CATH-05-62768	c2	fine	1.3	0.3	0.7	0.9	1.8	7.2	36.0	27.0	26.0	fsi	89.0	2.60	4.96
TH-1E	CATH-05-62769	c2	fine	1.8	1.1	3.0	2.4	2.5	8.2	39.7	20.7	22.4	csi	82.8	2.23	5.25
THM-1	CAPA-08-8465	c2	coarse	5.9	25.3	25.8	14.3	6.9	3.9	10.6	6.9	6.0	cs	23.5	99.7	1.67
THM-1	CATH-05-62770	c2	fine	0.5	3.7	11.3	13.8	11.5	12.7	25.6	10.8	10.7	vfs	47.1	2.37	5.50
THM-1	CATH-05-62771	c2	fine	1.2	5.8	18.6	23.5	12.4	9.6	16.0	5.8	8.4	fs	30.2	1.71	5.33
THM-1	CATH-05-62772	f1	fine	1.2	4.9	9.8	11.3	12.1	15.6	29.0	7.6	9.6	vfs	46.2	2.53	5.76
THM-1	CATH-05-62773	f1	fine	0.9	4.6	10.9	11.5	11.0	12.9	29.1	9.9	10.0	vfs	49.0	2.77	5.40
THM-1	CATH-05-62774	c2? (c3?)	coarse	21.5	57.2	25.5	6.1	1.7	1.0	2.4	3.0	3.1	vcs	8.5	0.45	5.72
THM-1	CATH-05-62775	c1	coarse	8.7	33.3	36.6	16.5	5.2	1.8	1.8	2.0	3.0	cs	6.8	0.27	5.98
THM-1	CATH-05-62776	c2? (c3?)	fine	0.3	1.6	7.0	11.5	12.6	15.1	30.2	11.1	10.8	csi	52.1	2.33	5.29
THM-1	CATH-05-62777	c2	fine	0.3	1.3	10.5	15.8	12.1	11.4	27.2	11.6	10.2	vfs	48.9	3.57	6.28
THM-1	CATH-05-62778	c2? (c3?)	fine	0.4	7.2	12.4	12.6	12.2	16.9	24.4	6.4	7.9	vfs	38.6	1.47	5.01
THM-1	CATH-05-62779	c2	coarse	25.5	38.3	31.1	15.0	4.0	1.7	3.8	3.1	3.1	cs	9.9	0.75	5.86
THS-1E	CATH-05-62780	c2	fine	1.1	5.2	13.9	15.3	11.7	13.5	23.3	8.0	9.1	vfs	40.3	2.33	5.25
THS-1E	CATH-05-62781	c1b	coarse	28.5	49.5	26.4	10.2	4.1	2.2	3.1	2.2	2.3	cs	7.7	0.36	6.32
THS-1E	CATH-05-62782	c1b	fine	2.8	7.9	11.1	10.7	9.1	11.2	28.9	10.1	10.8	vfs	49.8	1.80	5.37
THS-1E	CATH-05-62783	c1	coarse	17.9	53.7	31.5	7.9	1.8	0.6	1.3	1.7	1.5	vcs	4.4	0.26	5.93
THS-1E	CATH-05-62784	c2	fine	0.1	0.2	1.2	5.3	8.8	14.4	39.5	16.3	14.4	csi	70.2	2.06	5.60
THS-1E	CATH-05-62785	c2	fine	0.1	1.2	3.2	3.9	7.5	13.8	40.4	15.2	14.6	csi	70.3	2.30	5.28

Table B-1.0-3 (continued)

Reach	Sample ID	Unit	Facies	Gravel (> 2 mm) (wt %)	Very Coarse Sand (2-1 mm) (wt %)	Coarse Sand (1-0.5 mm) (wt %)	Medium Sand (0.5-0.25 mm) (wt%)	Fine Sand (0.25-0.125 mm) (wt %)	Very Fine Sand (0.125-0.0625 mm) (wt %)	Coarse Silt (62.5-15 µm) (wt%)	Fine Silt (15-2 µm) (wt%)	Clay (<2 µm) (wt%)	Median Particle Size Class ^a	Total Silt + Clay (wt%)	Organic Matter (wt %)	pH
THS-1E	CATH-05-62786	c2	coarse	6.0	25.7	35.2	22.5	6.8	2.5	2.6	1.7	2.8	cs	7.1	0.32	5.77
THS-1E	CATH-05-62787	c2	fine	0.9	8.2	10.8	5.8	8.0	11.5	31.2	13.2	11.4	csi	55.7	2.15	6.08
THS-1E	CATH-05-62788	c2	fine	0.1	1.6	3.8	5.2	9.1	15.3	36.6	14.2	14.2	csi	65.0	2.09	5.86
THS-1E	CATH-05-62789	f1	fine	0.2	0.0	0.1	0.7	2.2	7.2	39.9	29.9	20.0	csi	89.8	3.32	6.10
THS-1W	CATH-06-70655	c1	coarse	41.8	32.3	26.6	14.3	7.4	3.9	5.6	3.6	6.3	cs	15.5	0.76	5.98
THS-1W	CATH-06-70656	c2	fine	0.4	2.7	6.8	10.8	12.6	15.3	30.4	8.3	13.0	csi	51.7	2.10	6.14
THS-1W	CATH-06-70657	c2	fine	0.2	2.6	5.1	5.7	7.6	14.3	36.5	12.1	15.9	csi	64.6	2.44	5.73
THS-1W	CATH-06-70658	c2	coarse	52.6	33.9	23.3	11.4	6.1	4.8	9.8	4.4	6.2	cs	20.4	1.16	5.86
THS-1W	CATH-06-70659	f1	fine	0.9	6.3	8.9	8.5	7.9	12.3	30.0	12.7	13.2	csi	55.9	2.58	4.92
THS-1W	CATH-06-70660	c2	fine	0.3	1.2	2.9	6.0	12.7	18.9	37.2	8.2	12.8	csi	58.2	1.95	5.22
THS-1W	CATH-06-70661	c1	coarse	9.5	43.1	32.2	10.2	3.7	2.0	2.4	1.9	4.3	cs	8.6	0.42	5.88
THS-1W	CATH-06-70662	f1	fine	0.3	11.1	13.2	10.0	13.5	15.0	22.5	6.0	8.6	vfs	37.2	1.51	5.52
THS-1W	CATH-06-70663	c2	fine	3.9	8.5	12.0	8.7	6.7	11.9	31.5	8.2	12.3	csi	52.1	1.89	5.08
THS-1W	CATH-06-70664	f1	fine	0.6	9.1	12.1	11.5	12.2	16.2	22.9	5.7	10.3	vfs	38.9	1.88	5.73
THW-1	CATH-06-70668	c2	coarse	37.5	28.2	14.2	8.3	7.9	9.5	15.4	6.5	10.1	ms	31.9	2.49	4.97
THW-1	CATH-06-70669	c2	fine	30.9	7.7	4.3	2.8	3.1	7.6	41.7	17.4	15.4	csi	74.5	3.53	5.63
THW-1	CATH-06-70670	c2	fine	5.1	4.7	6.5	10.9	13.3	16.6	27.9	9.1	11.1	vfs	48.0	2.40	5.61
THW-1	CATH-06-70671	f1	fine	14.4	7.3	6.4	6.6	7.2	9.4	35.0	15.9	12.3	csi	63.2	4.95	5.45
THW-1	CATH-06-70672	c1	coarse	12.3	43.8	30.0	11.9	2.6	1.6	2.4	2.8	4.8	cs	10.0	0.64	5.73
THW-1	CATH-06-70673	c1	fine	4.8	2.2	3.0	4.0	6.9	15.0	40.9	12.9	15.0	csi	68.8	2.71	5.23
THW-1	CATH-06-70674	c2	fine	10.3	1.3	1.3	1.1	1.8	7.6	46.2	22.8	18.1	csi	87.1	3.60	5.66
THW-1	CATH-06-70675	f1	fine	55.9	5.9	7.3	4.1	3.4	9.3	39.7	11.6	18.8	csi	70.0	2.28	5.35
THW-1	CATH-06-70676	f1	fine	18.9	4.3	6.7	4.7	7.5	14.8	37.2	10.9	14.1	csi	62.1	5.34	5.45
THW-1	CATH-06-70677	f1	fine	3.3	1.1	2.6	2.7	3.3	5.7	33.0	34.7	16.8	fsi	84.5	3.87	5.66
TW-1E	CAPA-08-8458	f1	fine	5.8	5.5	11.0	14.0	12.4	11.3	24.7	10.4	10.5	vfs	45.7	2.59	6.73
TW-1E	CATW-05-61605	f1	fine	0.2	0.4	0.8	1.8	6.6	18.8	51.9	10.2	9.5	csi	71.6	1.71	4.23
TW-1E	CATW-05-61606	c1	coarse	53.2	25.1	30.0	24.6	9.5	2.9	2.4	2.2	3.4	cs	8.0	0.49	5.79
TW-1E	CATW-05-61607	c2	coarse	57.9	21.0	27.0	22.2	9.4	3.8	5.3	4.9	6.4	ms	16.5	1.10	5.38
TW-1E	CATW-05-61608	c2	fine	3.8	6.1	15.4	23.5	18.0	9.3	11.4	5.7	10.5	fs	27.5	1.52	4.87
TW-1E	CATW-05-61609	c2	fine	4.6	1.7	3.4	4.5	8.0	17.5	37.9	11.2	16.0	csi	65.1	2.41	4.74
TW-1E	CATW-05-61610	f1	fine	0.8	3.0	8.0	14.9	15.1	14.2	24.1	7.6	13.0	vfs	44.7	2.09	6.64
TW-1E	CATW-05-61611	c1b	coarse	55.0	30.2	33.1	23.2	5.9	1.5	0.5	2.7	2.7	cs	6.0	0.53	6.43
TW-1E	CATW-05-61612	c2	fine	0.3	3.2	9.5	13.9	13.1	11.8	26.0	9.8	12.4	vfs	48.2	2.62	5.17
TW-1E	CATW-05-61613	c1	coarse	54.8	32.6	31.4	20.0	5.9	1.5	1.4	4.0	3.1	cs	8.6	0.68	5.88
TW-1E	CATW-05-61614	c2	coarse	57.5	40.8	35.8	16.8	3.9	0.6	-0.9	1.7	1.5	cs	2.2	0.43	5.74
TW-1W	CAPA-08-8459	f1	fine	26.4	9.8	13.1	17.3	16.1	11.0	17.5	9.2	5.9	fs	32.6	2.46	6.77
TW-1W	CATW-06-70692	c1	coarse	35.7	48.8	30.8	11.4	3.0	0.9	0.7	2.6	1.8	cs	5.1	0.66	5.99

Table B-1.0-3 (continued)

Reach	Sample ID	Unit	Facies	Gravel (> 2 mm) (wt %)	Very Coarse Sand (2-1 mm) (wt %)	Coarse Sand (1-0.5 mm) (wt %)	Medium Sand (0.5-0.25 mm) (wt%)	Fine Sand (0.25-0.125 mm) (wt %)	Very Fine Sand (0.125-0.0625 mm) (wt %)	Coarse Silt (62.5-15 µm) (wt%)	Fine Silt (15-2 µm) (wt%)	Clay (<2 µm) (wt%)	Median Particle Size Class ^a	Total Silt + Clay (wt%)	Organic Matter (wt %)	pH
TW-1W	CATW-06-70693	c3	coarse	52.7	30.3	37.2	19.1	4.5	1.5	3.0	2.3	2.2	cs	7.5	0.59	5.19
TW-1W	CATW-06-70694	f1	fine	0.7	2.1	12.8	29.9	24.5	12.7	9.7	5.8	2.4	fs	17.9	1.55	6.44
TW-1W	CATW-06-70695	c2	coarse	44.2	34.4	37.7	17.7	3.5	0.9	1.0	2.5	2.4	cs	5.9	0.61	6.39
TW-1W	CATW-06-70696	f1	fine	12.6	6.9	17.9	23.0	15.0	9.4	14.5	7.9	5.7	fs	28.0	2.27	5.84
TW-1W	CATW-06-70697	f1	fine	5.6	1.6	5.7	6.6	7.4	11.7	37.4	20.3	9.5	csi	67.2	3.03	5.67
TW-1W	CATW-06-70698	c1	coarse	35.7	40.4	38.4	14.1	3.0	0.7	0.6	1.3	1.8	cs	3.7	0.34	5.97
TW-1W	CATW-06-70699	c2	coarse	44.7	27.9	23.4	20.8	9.7	3.9	5.8	4.4	4.0	cs	14.2	1.02	6.11
TW-1W	CATW-06-70700	c2	fine	3.1	3.3	10.7	13.6	12.9	13.7	35.5	5.5	4.9	vfs	45.9	2.12	7.32
TW-1W	CATW-06-70701	f1	fine	11.0	4.1	8.7	13.0	11.6	10.2	25.9	15.6	10.9	csi	52.4	4.77	7.19
TW-2E	CAPA-08-8462	c1	coarse	52.7	35.6	31.1	20.1	4.9	1.4	2.4	2.3	2.2	cs	6.9	0.40	6.33
TW-2E	CATW-07-4759	f1	fine	0.0	0.2	1.7	4.4	6.9	12.3	42.0	21.0	11.6	csi	74.6	—	5.28
TW-2E	CATW-07-4760	c2	fine	0.1	1.9	6.5	11.0	11.4	14.5	34.4	12.4	7.9	csi	54.7	—	6.34
TW-2E	CATW-07-4761	c3	fine	1.1	1.4	6.5	12.7	15.4	16.6	29.8	10.5	7.0	vfs	47.4	—	6.30
TW-2E	CATW-07-4762	c3	coarse	50.6	46.9	22.7	11.4	4.3	2.1	5.0	4.7	2.8	cs	12.5	—	6.27
TW-2E	CATW-07-4763	c1	coarse	49.9	64.8	25.4	4.4	0.8	0.5	1.1	1.5	1.5	vcs	4.1	—	6.30
TW-2E	CATW-07-4764	c1	coarse	50.1	42.7	25.0	16.4	5.4	1.9	3.7	3.2	1.9	cs	8.7	—	6.37
TW-2E	CATW-07-4765	f1	fine	2.4	10.1	15.0	14.4	13.9	13.6	20.5	6.1	6.4	fs	33.1	—	6.25
TW-2E	CATW-07-4766	c2	fine	0.3	1.7	7.1	14.4	16.2	15.6	29.2	8.5	7.4	vfs	45.1	—	6.37
TW-2E	CATW-07-4767	c2	coarse	26.9	35.8	31.4	15.5	5.1	2.0	4.0	4.1	2.1	cs	10.2	—	6.39
TW-2E	CATW-07-4768	f1	fine	0.4	0.2	2.7	6.9	11.6	16.8	38.3	13.7	9.9	csi	61.9	—	6.28
TW-3E	CATW-06-71114	f1	fine	0.9	0.9	6.3	20.0	20.4	15.6	22.5	8.2	6.3	vfs	37.0	1.92	5.85
TW-3E	CATW-06-71115	c1	coarse	32.9	50.4	30.3	10.2	2.8	1.1	0.7	1.8	2.7	vcs	5.3	0.30	5.94
TW-3E	CATW-06-71116	f1	fine	0.3	0.4	2.1	2.7	2.7	9.0	50.9	16.2	16.0	csi	83.1	2.38	6.05
TW-3E	CATW-06-71117	f1	fine	10.5	11.7	14.9	10.0	8.3	9.7	27.0	11.0	7.5	vfs	45.5	1.88	7.27
TW-3E	CATW-06-71118	c1	coarse	56.9	71.2	17.4	4.6	1.5	0.8	0.9	0.9	2.7	vcs	4.4	0.25	6.97
TW-3E	CATW-06-71119	c2	fine	20.9	2.7	5.2	6.0	5.4	7.2	33.8	22.2	17.8	csi	73.7	2.55	6.65
TW-3E	CATW-06-71120	f1	fine	0.3	0.3	4.4	17.1	19.3	17.1	25.0	8.0	8.8	vfs	41.9	2.40	6.26
TW-3E	CATW-06-71121	f1	fine	0.2	0.3	2.1	5.0	7.6	15.7	44.0	12.2	13.2	csi	69.4	2.05	6.39
TW-3E	CATW-06-71122	f1	fine	0.4	0.5	4.1	8.4	6.3	9.9	39.9	16.1	14.7	csi	70.7	2.14	6.16
TW-3E	CATW-06-71123	c2	coarse	18.6	38.2	34.8	13.6	3.7	1.6	2.1	2.3	3.8	cs	8.2	0.62	6.14
TW-4E	CATW-06-71061	c1	coarse	12.3	37.1	36.0	17.8	4.5	1.2	1.1	1.4	0.8	cs	3.3	0.23	6.33
TW-4E	CATW-06-71062	f2	fine	0.0	0.0	0.2	0.5	7.2	24.3	44.7	11.6	11.4	csi	67.8	3.18	6.50
TW-4E	CATW-07-4757	c2	fine	0.0	0.0	0.4	1.5	6.9	22.7	46.1	12.9	9.7	csi	68.6	—	6.16
TW-4E	CATW-07-4758	f1? (c2?)	fine	0.0	0.0	0.5	3.2	9.0	18.1	46.8	12.4	10.0	csi	69.2	—	6.12
TW-4W	CATW-05-62379	c2	coarse	46.4	40.5	29.8	12.9	3.7	1.4	3.3	4.3	4.1	cs	11.7	0.50	6.03
TW-4W	CATW-05-62380	c3	fine	10.2	5.2	9.0	15.2	13.9	14.6	28.5	7.7	5.8	vfs	42.1	1.61	5.84
TW-4W	CATW-05-62381	c3	fine	0.0	2.0	10.7	24.7	13.8	10.7	23.3	7.4	7.5	fs	38.2	1.45	5.94

Table B-1.0-3 (continued)

Reach	Sample ID	Unit	Facies	Gravel (> 2 mm) (wt %)	Very Coarse Sand (2-1 mm) (wt %)	Coarse Sand (1-0.5 mm) (wt %)	Medium Sand (0.5-0.25 mm) (wt%)	Fine Sand (0.25-0.125 mm) (wt %)	Very Fine Sand (0.125-0.0625 mm) (wt %)	Coarse Silt (62.5-15 µm) (wt%)	Fine Silt (15-2 µm) (wt%)	Clay (<2 µm) (wt%)	Median Particle Size Class ^a	Total Silt + Clay (wt%)	Organic Matter (wt %)	pH
TW-4W	CATW-05-62382	f1	fine	0.3	5.4	12.5	15.0	11.2	11.7	25.4	10.3	8.7	vfs	44.4	2.53	5.98
TW-4W	CATW-05-62383	c2	fine	1.4	0.4	2.9	11.1	20.8	18.3	30.2	8.8	7.6	vfs	46.6	2.45	6.31
TW-4W	CATW-05-62384	c1	coarse	1.3	19.0	51.2	22.2	3.9	0.9	0.7	0.4	1.7	cs	2.8	0.24	6.50
TW-4W	CATW-05-62403	f1	fine	0.1	1.0	1.8	1.8	3.2	15.0	44.7	15.6	16.9	csi	77.2	1.92	4.21
TW-4W	CATW-05-62404	c2	fine	2.7	8.4	17.0	23.2	15.3	10.7	14.6	5.7	5.4	fs	25.7	1.14	5.56
TW-4W	CATW-05-62405	c2	fine	24.3	16.7	20.7	18.8	9.9	7.2	14.6	6.5	5.7	ms	26.8	1.08	5.89
TW-4W	CATW-05-62406	f1	fine	3.7	4.6	13.3	20.4	12.6	10.0	21.3	8.9	8.6	fs	38.9	2.07	5.75
TWN-1E	CAPA-08-8460	c1	coarse	18.4	32.5	43.5	17.0	2.0	0.6	1.3	1.3	1.7	cs	4.3	0.37	6.75
TWN-1E	CATW-05-61615	f1	fine	0.0	0.5	2.1	3.4	9.0	21.5	42.7	10.1	10.7	csi	63.5	2.30	5.39
TWN-1E	CATW-05-61616	c1	fine	1.0	0.6	2.2	7.0	14.3	16.6	33.9	12.2	13.1	csi	59.2	4.07	5.46
TWN-1E	CATW-05-61617	c1	coarse	18.0	23.2	29.6	15.8	7.5	4.9	9.3	3.7	6.1	cs	19.0	1.59	5.88
TWN-1E	CATW-05-61618	c1	fine	0.7	1.1	3.3	5.2	6.0	13.8	42.0	15.6	13.1	csi	70.6	4.60	5.32
TWN-1E	CATW-05-61619	f1	fine	0.0	0.1	1.3	5.3	10.7	22.5	39.7	9.4	11.0	csi	60.1	2.24	5.38
TWN-1E	CATW-05-61620	f1	fine	0.0	0.8	5.2	15.1	19.5	16.6	28.3	5.8	8.7	vfs	42.8	1.83	5.51
TWN-1E	CATW-05-61621	c1	coarse	43.4	28.3	26.1	11.6	5.8	5.5	11.2	6.0	5.6	cs	22.7	1.06	5.79
TWN-1E	CATW-05-61622	c3	fine	0.0	1.0	6.7	14.5	13.4	15.4	29.8	9.7	9.7	vfs	49.2	2.61	4.84
TWN-1E	CATW-05-61623	c3	coarse	37.2	31.8	34.1	13.5	3.8	1.8	1.9	5.9	7.2	cs	14.9	0.66	5.53
TWN-1E	CATW-05-61624	c2	fine	0.2	0.5	2.9	4.8	6.7	9.7	35.6	22.3	17.5	csi	75.5	8.69	6.50
TWN-1E	CATW-06-70706	c1	coarse	34.3	29.6	43.6	18.2	3.3	1.0	0.8	2.6	0.9	cs	4.3	0.45	6.71
TWN-1E	CATW-06-70707	c1	coarse	14.5	29.0	39.0	20.2	4.1	1.5	2.6	1.4	2.3	cs	6.3	0.46	6.59
TWN-1W	CATW-06-70708	c2	fine	1.0	2.9	13.7	32.2	23.0	9.7	10.0	3.3	5.1	fs	18.5	1.63	5.20
TWN-1W	CATW-06-70709	c2	fine	1.0	5.0	14.8	11.4	7.8	10.0	29.9	10.1	10.9	csi	51.0	2.11	5.42
TWN-1W	CATW-06-70710	f1	fine	0.3	0.1	0.7	2.9	6.7	17.6	49.7	11.4	10.8	csi	71.9	2.45	5.40
TWN-1W	CATW-06-70711	c1	fine	0.6	0.2	1.1	2.8	8.9	11.6	39.0	22.2	14.2	csi	75.3	5.28	5.67
TWN-1W	CATW-06-70712	c2	coarse	21.2	25.2	38.0	29.3	4.6	0.9	-0.2	0.1	2.1	cs	2.0	0.26	5.79
TWN-1W	CATW-06-70713	c1	coarse	27.8	42.9	36.1	15.4	3.1	0.4	0.0	0.9	1.2	cs	2.1	0.30	6.06
TWN-1W	CATW-06-70714	c2	fine	0.3	0.7	3.8	7.6	14.3	21.6	31.2	10.1	10.6	csi	51.9	3.52	5.48
TWN-1W	CATW-06-70715	c1	coarse	44.4	31.0	36.1	24.7	4.9	0.7	0.4	0.4	1.8	cs	2.6	0.44	6.20
TWN-1W	CATW-06-70716	c2	coarse	50.6	36.6	33.9	12.0	3.7	2.6	5.0	2.2	3.9	cs	11.1	0.73	5.67
TWN-1W	CATW-06-70717	c2	fine	0.9	1.7	4.3	5.2	6.0	11.0	40.4	16.8	14.6	csi	71.8	2.45	5.57
TWSE-1E	CATW-05-62372	c1b	fine	0.0	0.3	2.2	4.8	7.2	9.4	28.5	26.6	21.0	csi	76.1	3.95	5.84
TWSE-1E	CATW-05-62373	c2	fine	0.4	1.9	8.6	9.7	9.3	11.1	29.9	16.4	13.1	csi	59.5	2.72	5.78
TWSE-1E	CATW-05-62374	c2	coarse	22.3	52.8	22.7	7.3	2.8	1.5	4.2	4.0	4.6	vcs	12.8	0.53	5.70
TWSE-1E	CATW-05-62375	c3	coarse	11.8	34.1	25.5	12.8	6.6	4.6	7.1	4.6	4.8	cs	16.5	0.72	6.10
TWSE-1E	CATW-05-62376	f1	fine	0.0	0.8	4.9	5.1	4.0	6.6	43.0	21.6	13.9	csi	78.5	2.48	5.90
TWSE-1E	CATW-05-62377	c1	coarse	12.9	45.9	31.7	9.6	2.5	1.1	1.9	3.6	3.6	cs	9.2	0.44	5.80
TWSE-1E	CATW-05-62378	f1	fine	2.1	7.9	17.1	17.1	12.5	9.7	19.5	7.7	8.5	fs	35.7	2.51	5.30

Table B-1.0-3 (continued)

Reach	Sample ID	Unit	Facies	Gravel (> 2 mm) (wt %)	Very Coarse Sand (2-1 mm) (wt %)	Coarse Sand (1-0.5 mm) (wt %)	Medium Sand (0.5-0.25 mm) (wt%)	Fine Sand (0.25-0.125 mm) (wt %)	Very Fine Sand (0.125-0.0625 mm) (wt %)	Coarse Silt (62.5-15 µm) (wt%)	Fine Silt (15-2 µm) (wt%)	Clay (<2 µm) (wt%)	Median Particle Size Class ^a	Total Silt + Clay (wt%)	Organic Matter (wt %)	pH
TWSE-1E	CATW-05-62400	c2	fine	0.1	0.4	3.5	6.4	7.2	10.0	34.2	21.1	17.3	csi	72.5	3.59	5.82
TWSE-1E	CATW-05-62401	c3	fine	0.1	2.7	11.5	13.6	10.3	13.4	28.9	9.9	9.8	vfs	48.6	2.15	6.01
TWSE-1E	CATW-05-62402	f1	fine	0.2	1.7	9.0	13.0	13.6	12.5	27.6	12.7	10.0	csi	50.3	2.70	4.90
TWSE-1W	CAPA-08-8461	c2	fine	0.3	0.5	1.9	1.9	1.9	8.1	54.0	16.2	15.5	csi	85.7	2.20	6.49
TWSE-1W	CATW-06-71076	f1	fine	1.7	0.3	1.1	1.9	3.2	11.2	51.1	17.6	13.6	csi	82.3	3.28	5.74
TWSE-1W	CATW-06-71077	c2	fine	1.1	0.6	2.7	4.6	4.8	13.9	42.3	13.7	17.5	csi	73.4	2.60	5.81
TWSE-1W	CATW-06-71078	c2	fine	0.2	0.6	1.8	2.2	2.7	10.0	44.7	16.9	21.2	csi	82.7	2.96	5.64
TWSE-1W	CATW-06-71079	c2	fine	0.1	0.5	1.4	1.3	1.1	6.3	54.1	18.3	17.1	csi	89.4	2.44	5.86
TWSE-1W	CATW-06-71080	c2	fine	0.2	0.3	1.5	1.6	2.2	12.0	43.5	18.0	20.9	csi	82.4	2.86	5.86
TWSE-1W	CATW-06-71081	c2	fine	1.8	5.6	6.4	2.6	2.5	10.8	40.1	12.7	19.2	csi	72.0	1.97	5.86
TWSE-1W	CATW-06-71082	f1	fine	0.0	0.0	0.1	0.3	0.4	3.9	59.0	19.7	16.6	csi	95.3	2.83	6.21
TWSE-1W	CATW-06-71083	f1	fine	0.1	0.1	0.4	1.1	3.7	17.0	49.6	9.9	18.2	csi	77.7	2.68	6.45
TWSE-1W	CATW-06-71084	f1	fine	0.0	0.0	0.1	0.4	0.9	8.6	62.5	14.3	13.1	csi	89.8	2.37	6.47
TWSE-1W	CATW-06-71085	c1	coarse	20.0	39.1	36.8	7.9	2.2	1.4	3.7	3.0	5.6	cs	12.4	0.47	6.53
TWSW-1E	CATW-05-62366	c2	coarse	22.9	45.0	19.7	6.8	3.0	3.0	7.7	6.3	8.5	cs	22.4	1.01	5.56
TWSW-1E	CATW-05-62367	c2	fine	0.4	1.1	3.9	6.1	8.5	17.7	36.2	12.4	14.0	csi	62.6	4.03	6.34
TWSW-1E	CATW-05-62368	c2	fine	0.0	2.0	6.5	5.5	4.8	14.7	42.5	8.4	15.5	csi	66.4	1.83	5.87
TWSW-1E	CATW-05-62369	c1	coarse	8.1	47.5	34.9	8.5	1.6	0.8	-0.2	2.0	4.7	cs	6.5	0.23	6.27
TWSW-1E	CATW-05-62370	c2	fine	1.1	6.0	12.3	11.0	9.6	11.8	26.7	11.4	11.1	vfs	49.2	3.39	6.62
TWSW-1E	CATW-05-62371	c2	fine	0.2	2.2	4.3	3.6	3.9	10.1	34.6	15.9	25.3	csi	75.8	2.75	5.78
TWSW-1E	CATW-05-62396	f1	fine	0.0	0.1	0.7	1.8	2.7	7.4	41.6	28.3	17.4	csi	87.3	2.80	4.90
TWSW-1E	CATW-05-62397	f1	fine	0.0	0.0	0.8	1.2	1.4	4.6	43.5	29.0	19.4	csi	91.9	3.00	4.89
TWSW-1E	CATW-05-62398	c2	fine	0.5	7.6	12.5	6.6	4.9	10.9	31.0	11.8	14.6	csi	57.4	2.39	5.61
TWSW-1E	CATW-05-62399	f1	fine	0.2	2.6	8.1	8.3	6.3	10.2	35.1	14.0	15.4	csi	64.5	2.63	5.38
TWSW-1W	CATW-06-71089	c2	fine	0.1	0.2	1.1	1.0	0.9	3.3	34.7	32.6	26.1	fsi	93.5	3.51	5.67
TWSW-1W	CATW-06-71090	c2	fine	0.5	0.6	1.6	2.6	4.9	14.6	46.7	13.1	15.7	csi	75.6	2.46	5.52
TWSW-1W	CATW-06-71091	c1	coarse	24.6	25.2	44.0	16.9	2.5	1.0	3.9	1.5	4.8	cs	10.2	0.67	6.45
TWSW-1W	CATW-06-71092	f1	fine	0.1	0.0	0.3	1.1	4.8	17.9	51.6	10.0	14.2	csi	75.8	3.07	5.21
TWSW-1W	CATW-06-71093	f1	fine	2.2	1.5	3.9	4.1	4.4	9.5	41.5	16.7	18.3	csi	76.5	3.20	5.76
TWSW-1W	CATW-06-71094	c2	fine	1.8	2.0	4.9	4.3	2.9	6.3	36.8	19.9	22.8	csi	79.5	2.93	5.94
TWSW-1W	CATW-06-71095	c2	fine	0.3	0.2	1.1	1.7	2.4	9.3	52.0	17.8	15.6	csi	85.3	3.20	5.69
TWSW-1W	CATW-06-71096	f1	fine	0.6	0.4	1.6	2.7	4.9	12.2	41.0	16.4	20.8	csi	78.2	2.95	6.08
TWSW-1W	CATW-06-71097	f1	fine	0.7	0.1	0.7	1.4	2.9	9.2	38.6	22.2	24.6	csi	85.5	3.10	5.77
TWSW-1W	CATW-06-71098	c2	fine	0.6	0.4	2.5	3.3	3.5	8.2	39.9	20.6	21.7	csi	82.2	3.62	5.77

^a Median particle size class in < 2 mm fraction; cs = coarse sand; csi = coarse silt; fs = fine sand; fsi = fine silt; ms = medium sand; vcs = very coarse sand; vfs = very fine sand.

^b Dash indicates data not obtained.

Table B-3.0-1
Sediment Samples Submitted for Laboratory Analysis

Sample ID	Reach	Location ID	Geomorphic Unit	Depth (cm)	Date Collected	Notes
CAPA-08-8446	AEN-1	PA-24871	f1	0-30	11/7/07	Earthworm toxicity test and seedling germination test
CAPA-08-8447	AW-1	PA-26410	c2	0-30	11/6/07	Earthworm toxicity test and seedling germination test
CAPA-08-8448	PA-0	PA-26500	f1	0-30	11/7/07	Earthworm toxicity test and seedling germination test
CAPA-08-8449	PA-1E	PA-603098	c2	0-30	11/6/07	Earthworm toxicity test and seedling germination test
CAPA-08-8450	PA-4	PA-22890	c1 pool	0-30	11/6/07	Earthworm toxicity test and seedling germination test
CAPA-08-8451	PAS-1E	PA-26418	c2	0-30	11/6/07	Earthworm toxicity test and seedling germination test
CAPA-08-8452	AW-1	PA-603101	c1	0-15	11/6/07	<i>Chironomous tentans</i> test
CAPA-08-8453	PA-0	PA-603102	c1	0-15	11/7/07	<i>Chironomous tentans</i> test
CAPA-08-8454	PA-4	PA-603103	c1	0-15	11/6/07	<i>Chironomous tentans</i> test
CAPA-08-8455	PAS-2E	PA-603104	c1	0-15	11/7/07	<i>Chironomous tentans</i> test
CAPA-08-8456	PA-1E	PA-603098	c2	0-30	11/6/07	QA duplicate from earthworm and seedling test location
CATW-08-8458	TW-1E	TW-24830	f1	0-30	11/7/07	Earthworm toxicity test and seedling germination test
CATW-08-8459	TW-1W	TW-26460	f1	0-30	11/7/07	Earthworm toxicity test and seedling germination test
CATW-08-8460	TWN-1E	TW-24836	c1	0-30	11/7/07	Earthworm toxicity test and seedling germination test
CATW-08-8461	TWSE-1W	TW-26524	c2	0-30	11/7/07	Earthworm toxicity test and seedling germination test
CATW-08-8462	TW-2E	TW-603109	c1	0-15	11/7/07	<i>Chironomous tentans</i> test
CATW-08-8463	TWN-1E	TW-24836	c1	0-30	11/7/07	QA duplicate from earthworm and seedling test location
CATH-08-8465	THM-1	TH-25024	c2	0-30	11/6/07	Earthworm toxicity test and seedling germination test

Table B-3.0-2
Crosswalk between Sample IDs for
Earthworm Analyses and Sediment Analyses

Earthworm Sample ID	Sediment Sample ID	Reach	Location ID	Depth (cm)
CAPA-08-11160	CAPA-08-8446	AEN-1	PA-24871	0-30
CAPA-08-11161	CAPA-08-8447	AW-1	PA-26410	0-30
CAPA-08-11162	CAPA-08-8448	PA-0	PA-26500	0-30
CAPA-08-11163	CAPA-08-8449	PA-1E	PA-603098	0-30
CAPA-08-11164	CAPA-08-8450	PA-4	PA-22890	0-30
CAPA-08-12045	n/a*	n/a	n/a	n/a
CAPA-08-12046	CAPA-08-8451	PAS-1E	PA-26418	0-30
CATH-08-11171	CATH-08-8465	THM-1	TH-25024	0-30
CATW-08-11166	CATW-08-8458	TW-1E	TW-24830	0-30
CATW-08-11167	CATW-08-8459	TW-1W	TW-26460	0-30
CATW-08-11168	CATW-08-8460	TWN-1E	TW-24836	0-30
CATW-08-11169	CATW-08-8461	TWSE-1W	TW-26524	0-30
CATW-08-11170	n/a	n/a	n/a	n/a

* n/a = Not applicable; analytical laboratory control sample.

Table B-3.0-3
Egg, Nestling, and Insect Samples Submitted for Laboratory Analysis

Sample ID	Location ID	Sub-Watershed	Reach or General Location	Nest Box Number(s)	Type of Sample	Species Name
CAPA-08-11627	PA-603362	Pajarito	TA-14, south of PA-1E	830	Egg	Western bluebird
CAPA-08-11884	PA-603374	Pajarito	AW-1	846, 848	Insect	n/a*
CAPA-08-11885	PA-603375	Pajarito	PAS-1E	855	Insect	n/a
CAPA-08-11886	PA-603376	Pajarito	PA-2W	794, 800	Insect	n/a
CAPA-08-11887	PA-603377	Pajarito	PA-3E	808, 809	Insect	n/a
CATH-08-11628	TH-603363	Threemile	TA-15, R-44 firing site	419	Egg	Ash-throated flycatcher
CATW-08-11629	TW-603364	Pajarito	AW-1	845	Nestling	Western bluebird
CATW-08-11888	TW-603378	Twomile	TWSE-1W	831, 834, 835, 836, 839	Insect	n/a

* n/a = Not applicable.

Appendix C

Analytical Data

C-1.0 ANALYTICAL RESULTS

Data packages are included in Attachment 1 on DVDs. Data related to the Pajarito watershed are presented on a CD in Attachment 2. Data obtained from the Environmental Restoration Database (ERDB) and Water Quality Database (WQDB) are grouped by sediment, surface water, groundwater, core, and biota. Data are further subdivided into analytical data (those data used in analyses presented in this report), field-quality control (QC) data and rejected data. Data obtained from sources other than the ERDB and WQDB are also included on the CD.

C-1.1 ERDB and WQDB Data

The following tables containing ERDB and WQDB data are included on the CD:

- Table C-1.1-1 Pajarito Sediment Inorganic Chemical and Radionuclide Analytical Data
- Table C-1.1-2 Pajarito Sediment Organic Chemical Analytical Data
- Table C-1.1-3 Pajarito Sediment Other Analytical Data
- Table C-1.1-4 Pajarito Sediment Field QC Data
- Table C-1.1-5 Pajarito Sediment Rejected Data
- Table C-1.1-6 Pajarito Surface-Water Analytical Data
- Table C-1.1-7 Pajarito Surface-Water Field QC Data
- Table C-1.1-8 Pajarito Surface-Water Rejected Data
- Table C-1.1-9 Pajarito Groundwater Inorganic Chemical and Radionuclide Analytical Data
- Table C-1.1-10 Pajarito Groundwater Organic Chemical Analytical Data Part 1
- Table C-1.1-11 Pajarito Groundwater Organic Chemical Analytical Data Part 2
- Table C-1.1-12 Pajarito Groundwater Field QC Data
- Table C-1.1-13 Pajarito Groundwater Rejected Data
- Table C-1.1-14 Pajarito Core Analytical Data
- Table C-1.1-15 Pajarito Core Field QC Data
- Table C-1.1-16 Pajarito Core Rejected Data
- Table C-1.1-17 Pajarito Biota Analytical Data
- Table C-1.1-18 Pajarito Biota Field QC Data

C-1.2 Data Obtained from Other Sources

Data obtained from sources other than the ERDB and WQDB are also included on the CD:

- Table C-1.2-1 Hydrology, Geochemistry, and Geology Regional Well Core Leachate and Moisture Data
- Table C-1.2-2 Sediment Particle-Size Data
- Table C-1.2-3 Nest Box Egg Measures
- Table C-1.2-4 Nest Box Success Measures

- Water-Level Data
- Spinner-Log Data

C-2.0 SUMMARY OF SAMPLES COLLECTED

Samples collected in the Pajarito watershed and analyses performed by analytical laboratories are summarized in Tables C-2.0-1 (sediment), C-2.0-2 (surface water), C-2.0-3 (groundwater), C-2.0-4 (core), and C-2.0-5 (biota). Media code definitions are provided in Table C-2.0-6.

C-3.0 SAMPLE COLLECTION METHODS

Historical groundwater samples have been collected using a variety of sampling methods: automated pump sampler, bailer, bladder pump, direct container grab sampling, discharge pipe/faucet, gear-driven submersible pump, peristaltic pump, transfer device for grab samples, weighted bottle, or West Bay sampler. Historical surface-water samples have been collected using automated pump samplers, bailers, direct container grab sampling, peristaltic pumps, single-stage samplers, or transfer devices for grab samples. Historical stormwater samples have been collected using an automated pump sampler, direct container grab sampling, or single-stage samplers.

Current Los Alamos National Laboratory (LANL or the Laboratory) standard operating procedures (SOPs) for water sampling methods are

- SOP-06.01, Revision 3, "Purging and Sampling Methods for Single Completion Wells,"
- SOP-06.13, Revision 2, "Surface-Water Sampling,"
- SOP-06.29, Revision 2, "Single-Stage Sampling for Surface Water Run-Off," and
- SOP-06.32, Revision 2, "Multi-Level Groundwater Sampling of Monitoring Wells, Westbay MP System."

Historical sediment samples have been collected using a spade and scoop or a hand auger and thin-wall tube sampler.

Current Laboratory SOPs for sediment sampling methods are

- SOP-06.09, Revision 2, "Spade and Scoop Method for Collection of Soil Samples," and
- SOP-06.10, Revision 3, "Hand Auger and Thin-Wall Tube Sampler."

Historical core samples have been collected using a core barrel samples, a hollow-stem auger, or split-spoon samplers and Shelby tube samplers.

Current Laboratory SOPs for core sampling methods are

- SOP-06.24, Revision 2, "Sample Collection from Split Spoon Sampler and Shelby Tube Samplers," and
- SOP-06.26, Revision 2, "Core Barrel Sampling for Subsurface Earth Materials."

C-4.0 ANALYTICAL PROGRAM

Data contained in this report were obtained from the ERDB and the WQDB.

Data validation for data from the WQDB is performed by an outside contractor that validates the analytical data according to U.S. Environmental Protection Agency (EPA) protocols. All of the data from analytical

laboratories that provide level 4 data packages are validated. Level 4 data packages are defined as those containing chain-of-custody forms, quality assurance (QA) and QC documentation, the analytical laboratory form 1 (a summary of the analytical results), and the raw analytical data. Data packages are included in Attachment 1 on DVDs.

For data obtained from the ERDB, QA, QC, and data validation procedures were implemented in accordance with the requirements of the Los Alamos National Laboratory Quality Assurance Project Plan Requirements for Sampling and Analysis (LANL 1996, 054609) and the Laboratory's analytical services statements of work (SOWs) for contract laboratories (LANL 1995, 049738; LANL 2000, 071233). All data obtained from the ERDB that are included in this report have accompanying level 4 data packages and have undergone routine validation according to SOPs specific to the analyte type (inorganic chemicals, organic chemicals, or radionuclides). The current SOPs include the following:

- SOP-5161, Revision 0, "Routine Validation of Volatile Organic Data"
- SOP-5162, Revision 0, "Routine Validation of Semivolatile Organic Compound (SVOC) Analytical Data"
- SOP-5163, Revision 0, "Routine Validation of Organochlorine Pesticide and PCB Analytical Data"
- SOP-5164, Revision 0, "Routine Validation of High Explosive Analytical Data"
- SOP-5165, Revision 0, "Routine Validation of Metals Analytical Data"
- SOP-5166, Revision 0, "Routine Validation of Gamma Spectroscopy, Chemical Separation Alpha Spectrometry, Gas Proportional Counting, and Liquid Scintillation Analytical Data"
- SOP-5191, Revision 0, "Routine Validation of LC/MS/MS Perchlorate Analytical Data (SW-846 EPA Method 6850)"

Some analytical results were rejected for various reasons and are not usable for the purposes of this report. In some of these instances, the analysis was rerun and a valid result exists. However, some rejected data represent data issues; there is no valid result for the analyte for the given sample. Rejected results that represent data issues are provided on the data CD and discussed in Section C-8.0. Field duplicates are used for QC purposes and are not included in the summary tables in Section 6 of the report. When there were duplicate analytical results for an analyte in the same sample resulting from two methods, the result obtained from the more sensitive method (i.e., lower detection limit) was presented in the summary tables in Section 6 of the report. Reporting qualifiers are presented in parentheses next to the results in the summary tables. Reporting qualifier definitions are listed in Table C-4.0-1.

C-5.0 INORGANIC CHEMICAL ANALYSIS METHODS

The analytical methods used for inorganic chemicals are listed in Table C-5.0-1.

Laboratory control samples (LCSs), method blanks, matrix spike (MS) samples, and field duplicate samples were analyzed to assess accuracy and precision of inorganic chemical analyses. Each of these QA/QC sample types is defined in the analytical services SOWs (LANL 1995, 049738; LANL 2000, 071233) and is described briefly in the sections below.

The LCS serves as a monitor of the overall performance of each step during the analysis, including sample digestion. The analytical results for the samples were qualified according to National Functional Guidelines (EPA 1994, 048639) if the individual LCS recovery indicated an unacceptable bias in the measurement of individual analytes. LCS recoveries should fall into the control limits of 75%–125% (LANL 1995, 049738; LANL 2000, 071233).

Method blanks are used as a measurement of bias and potential cross-contamination. All target analytes should be below the contract-required detection limit (CRDL) in the preparation blank (LANL 1995, 049738; LANL 2000, 071233).

The accuracy of inorganic chemical analyses is also assessed using MS samples. An MS sample is designed to provide information about the effect of each sample matrix on the sample preparation procedures and analytical technique. The spike sample recoveries should be within the acceptance range of 75%–125% (LANL 1995, 049738; LANL 2000, 071233).

Analyzing field duplicate samples assesses the precision of analyses. All relative percent differences (RPDs) between the sample and field duplicate should be $\pm 35\%$ (LANL 1995, 049738; LANL 2000, 071233).

The validation of inorganic chemical data using QA/QC samples and other methods can result in the rejection of the data or the assignment of various qualifiers to individual sample results. Reporting qualifier definitions are listed in Table C-4.0-1.

Inorganic Chemical Background Values

It is important to note that the previously used analytical services SOW (LANL 1995, 049738) was issued before the widespread use of axial view inductively coupled plasma emission spectroscopy (ICPES) (also known as trace ICPES). With the advent of axial view ICPES, detection limits for inorganic chemicals have greatly improved. For example, antimony soil detection limits for the older radial view ICPES are typically on the order of 12 mg/kg, whereas axial view ICPES detection limits are as low as 0.5 mg/kg.

“Inorganic and Radionuclide Background Data for Soils, Canyon Sediments, and Bandelier Tuff at Los Alamos National Laboratory” (LANL 1998, 059730) was developed after axial view ICPES was widely used. However, since some of the samples were collected and analyzed before widespread axial view ICPES use, not all detection limits are below the background values (BVs). Sample results with detection limits above the BVs are presented in the data summary tables.

Calculated Total Uranium

Total inorganic uranium was calculated from isotopic uranium to compare uranium to the inorganic sediment background value and soil screening values. The specific activity used to convert isotopic data to total uranium is presented in “Inorganic and Radionuclide Background Data for Soils, Canyon Sediments, and Bandelier Tuff at Los Alamos National Laboratory” (LANL 1998, 059730).

C-6.0 ORGANIC CHEMICAL ANALYSIS METHODS

The analytical methods used for organic chemicals are listed in Table C-6.0-1.

QCs are designed to produce a quantitative measure of the reliability of a specific part of an analytical procedure. The results of the QCs performed on a sample provide confidence about whether the analyte is present and whether the concentration reported is correct. The validation of organic chemical data using QA/QC samples and other methods can result in rejecting the data or in assigning various qualifiers to individual sample results. Reporting qualifier definitions are listed in Table C-4.0-1.

Calibration verifications, instrument-performance checks, LCSs, method blanks, MS samples, surrogates, and internal standards (ISs) were analyzed to assess the accuracy and precision of the organic chemical analyses. Each of these QA/QC sample types is defined in the analytical services SOWs (LANL 1995, 049738; LANL 2000, 071233) and is described briefly below.

Calibration verification, which consists of initial and continuing verification, is the establishment of a quantitative relationship between the response of the analytical procedure and the concentration of the target analyte. The initial calibration verifies the accuracy of the calibration curve and the individual calibration standards used to perform the calibration. The continuing calibration ensures that the initial calibration is still holding and correct as the instrument is used to process samples. The continuing calibration also serves to determine whether analyte identification criteria, such as retention times and spectral matching, are being met.

The LCS is a sample of a known matrix that has been spiked with compounds that are representative of the target analytes, and it serves as a monitor of the overall performance of a "controlled" sample. Daily, the LCS is the primary demonstration of the ability to analyze samples with good qualitative and quantitative accuracy. The analytical results for the samples were qualified according to National Functional Guidelines (EPA 1999, 066649) if the individual LCS recoveries were not within method-specific acceptance criteria. The LCS recoveries should fall within the control limits of 75%–125% (LANL 1995, 049738; LANL 2000, 071233).

A method blank is an analyte-free matrix to which all reagents are added in the same volumes or proportions as those used in the environmental sample processing and which is extracted and analyzed in the same manner as the corresponding environmental samples. Method blanks are used to assess the potential for sample contamination during extraction and analysis. All target analytes should be below the CRDL limit in the method blank (LANL 1995, 049738; LANL 2000, 071233).

The accuracy of organic chemical analyses is also assessed by using MS samples that are aliquots of the submitted samples spiked with a known concentration of the target analyte(s). MS samples are used to measure the ability to recover prescribed analytes from a native sample matrix. Spiking typically occurs before sample preparation and analysis. The spike sample recoveries should be within the acceptance range of 75%–125% (LANL 1995, 049738; LANL 2000, 071233).

A surrogate compound (surrogate) is an organic chemical compound used in the analyses of organic target analytes that is similar in composition and behavior to the target analytes but not normally found in environmental samples. Surrogates are added to every blank, sample, and spike to evaluate the efficiency with which analytes are recovered during extraction and analysis. The recovery percentage of the surrogates must be within specified ranges or the sample may be rejected or assigned a qualifier (LANL 1995, 049738; LANL 2000, 071233).

Internal standards are chemical compounds added to every blank, sample, and standard extract at a known concentration. They are used to compensate for (1) analyte concentration changes that might occur during storage of the extract and (2) quantitation variations that can occur during analysis. ISs are used as the basis for quantitation of target analytes. The percent recovery for ISs should range between 50% and 200% (LANL 1995, 049738; LANL 2000, 071233).

C-7.0 RADIOCHEMICAL ANALYSIS METHODS

Radionuclides were analyzed by the methods listed in Table C-7.0-1. Radionuclides with reported values less than the minimum detectable activity were qualified as nondetected (U). Each radionuclide result was also compared with the corresponding one sigma total propagated uncertainty (TPU). If the result was not greater than 3 times the TPU, the radionuclide was qualified as nondetected (U).

The precision and bias of radiochemical analyses performed at off-site fixed laboratories were assessed using MS samples, LCSs, method blanks, and duplicates. The analytical services SOWs (LANL 1995, 049738; LANL 2000, 071233) specify that spike sample recoveries should be within $\pm 25\%$ of the certified value. LCSs were analyzed to assess the accuracy of radionuclide analyses. The LCSs serve as a

monitor of the overall performance of each step during the analysis, including the radiochemical separation preparation. The analytical services SOWs (LANL 1995, 049738; LANL 2000, 071233) specify that LCS recoveries should be within $\pm 25\%$ of the certified value. Method blanks are also used to assess bias. The analytical services SOWs (LANL 1995, 049738; LANL 2000, 071233) specify that the method blank concentration should not exceed the required estimated quantitation limit (EQL).

C-8.0 DATA QUALITY

Data quality issues, including rejected analytical results, are summarized by media. Because of the large number of records that were qualified, the following sections provide a summary of the reasons for qualification, and the qualification is not addressed by individual records.

C-8.1 Sediment Data

Sediment samples were collected in Pajarito Canyon. A total of 68,485 results from sediment samples in this canyon were reported. Of these results, 305 results were rejected during data validation. These rejected results represent less than 1% of all the sediment results.

Ninety-two inorganic chemical results were rejected for antimony because the sample spike recovery was less than 30%. A total of 133 radionuclide results for samples analyzed by gamma spectroscopy were rejected because spectral interference prevented positive identification of the analytes. Thirty-three SVOC results were rejected because either the LCS percent recovery was less than 10% or the affected results were not analyzed with a valid 5-point calibration curve and/or a standard at the reporting limit (RL). Twenty high explosive chemical results were also rejected because the LCS percent recovery was less than 10%. Seventeen pesticide and polychlorinated biphenyl (PCB) results were rejected because the LCS percent recovery was less than 10%. Ten VOC results were rejected because of an RRF of less than 0.05 in the initial calibration and/or CCV.

A total of 2496 inorganic chemical results were reported as estimated, either detected or not detected. All inorganic chemical results that are detected and are between the method detection limit (MDL) and the EQL are qualified as estimated. Anion results were estimated because the analyte was recovered below the lower acceptance limit (LAL) but greater than 30% in the associated spike sample.

All metals results that were estimated were due to one of the following:

- the analyte was recovered below the lower acceptance level but greater than 30% in the associated spike sample
- the MS was analyzed on a non-Laboratory sample
- the analyte was recovered above the upper acceptance limit (UAL) but less than 150% of the associated spike sample
- the associated LCS was recovered above the upper warning limit
- the associated LCS was recovered below the lower warning limit but greater than or equal to the LAL
- the samples were analyzed after the appropriate holding time had passed
- the duplicate sample was analyzed on a non-Laboratory sample

- both the sample and duplicate sample results were greater than or equal to 5 times the RL and the duplicate RPD was greater than 35% for soil samples
- either the sample or duplicate sample results or both were greater than or equal to 5 times the RL and the difference between the samples is greater than 2 times the RL for soil samples
- the associated initial calibration verification (ICV) or continuing calibration verification (CCV) was recovered above the upper warning limit but is less than or equal to the UAL
- the serial dilution sample RPD was greater than 10% and the sample result was greater than 50 times the MDL (greater than 100 times the MDL for ICPMS)

Eleven radionuclide results were either estimated and biased low or reported as estimated because either the associated tracer recovery was less than 30% but greater than 10% or because the associated LCS failed low but greater than 10% .

A total of 8311 organic chemical results were reported as estimated, either detected or not detected, based on one of the following issues:

Volatiles: Volatile chemical results were estimated because

- the associated IS area counts are less than 50% or greater than 200% of the previous continuing calibration standard,
- the sample surrogate recovery was greater than the UAL,
- the sample surrogate recovery was less than the LAL but greater than or equal to 10%,
- the associated %RSD/%D exceeded criteria in the initial or continuing calibration standards,
- the extraction/analytical holding time was exceeded by less than 2 times the published method holding time requirement,
- the associated LCS recovery was less than the LAL but greater than 10%, or
- the validator identified quality deficiencies in the reported data that require qualification.

Semivolatiles: Semivolatile chemical results were estimated because

- the associated IS area counts are less than 50% but greater than 10% recovery when compared with the area counts in the applicable continuing calibration standard,
- at least two sample surrogate recoveries in the same fraction were less than the LAL but greater than 10% recovery,
- the associated sample concentration was greater than 5 times/10 times the amount in the method blank,
- the associated %RSD/%D exceeded the criteria in the initial or continuing calibration standards,
- the extraction holding time was exceeded by less than 2 times the published method for holding time,
- the associated LCS recovery was less than LAL but greater than 10% recovery,

- the associated LCS recovery was greater than UAL, or
- the validator identified quality deficiencies in the reported data that require qualification.

Pesticides and PCBs: Pesticide and PCB results were estimated because

- the associated surrogate was recovered above the UAL,
- the associated surrogate was recovered below the LAL but greater than or equal to 10% recovery,
- the associated %RSD or %D exceeded criteria in the initial or continuing calibration standards,
- the associated continuing calibration standard was not analyzed within 72 h of the initial analysis,
- the pattern in the sample does not adequately match the pattern for the analyte in the standard, or
- the extraction holding time was exceeded.

PAHs: PAH results were estimated because

- at least two sample surrogate recoveries in the same fraction were less than the LAL but greater than 10% recovery,
- the extraction holding time was exceeded by less than 2 times the published method for holding time,
- the associated LCS recovery was less than LAL but greater than 10% recovery, or
- the associated LCS recovery was greater than UAL.

High Explosives: High explosives results were estimated because

- the associated %RSD/%D exceeded the criteria in the initial or continuing calibration standards,
- the extraction holding time was exceeded by less than 2 times the published method for holding time, or
- the validator identified quality deficiencies in the reported data that require qualification.

Dioxin/Furan: Dioxin and furan results were estimated because the associated sample concentration was greater than 5 times/10 times the amount in the method blank or the validator identified quality deficiencies in the reported data that require qualification.

C-8.2 Water Data

A total of 146,765 results from water samples collected in Pajarito were reported. Of these results, 2548 results were rejected during data validation. These rejected results represent about 1.7% of the water sample results.

A total of 420 inorganic chemical results were rejected because either

- the spike percent recovery value was less than 30%,

- the analyte was identified in the method blank,
- the holding time was exceeded,
- the duplicate sample RPD was greater than the advisory limit,
- the duplicate sample analysis was not performed on a sample associated with the same request number,
- the MS analysis was not performed on a sample associated with the same request number,
- negative blank sample results were greater than the MDL,
- there was a serial dilution RPD outside of acceptance limits, or
- other QC failure.

One hundred forty-nine radionuclide results were rejected because

- the tracer/carrier percent recovery was less than 10%,
- the MS percent recovery was less than 10%,
- the MS percent recovery was less than the lower limit,
- the method blank information was missing,
- the duplicate and sample result had a duplicate error ratio that was greater than 2.0,
- the relative error ratio was greater than 4,
- the result was less than 3 times the minimum detectable concentration,
- the result was less than the negative minimum detectable concentration, or
- other QC failure.

A total of 1979 organic chemical results were rejected based on the following issues:

Volatiles: Volatile chemical results were rejected because

- the affected analytes were analyzed with a relative response factor of less than 0.05,
- the analytical and/or extraction holding time was exceeded,
- the LCS percent recovery was less than 10%,
- the spike percent recovery value was less than 10%,
- the sample was improperly preserved,
- the calibration verification percent difference was greater than the acceptance criteria but less than 60%, or
- other QC failure.

Semivolatiles: Semivolatile chemical results were rejected because

- the affected analyte was analyzed with a relative response factor of less than 0.05,
- the LCS documentation was missing,
- the LCS percent recovery was less than 10%,
- the required calibration information was missing or samples were analyzed on an expired calibration,
- the RPD of the MS/matrix spike duplicate (MSD) was greater than the acceptance criteria,
- the spike percent recovery value was less than 10%,
- the calibration percent RSD exceeded 60%, or
- other QC failure.

PCBs: PCB results were rejected because the extraction/analytical holding time was exceeded by greater than 2 times the published method for holding times.

High Explosives: High explosives results were rejected because

- the surrogate percent recovery was greater than the UAL,
- the surrogate recovery was less than 10%,
- the LCS analyte percent recovery was less than the LAL and greater than or equal to 10% recovery,
- the holding time was exceeded,
- the associated retention times shifted by more than 0.05 min from the mid-level standard of the initial calibration,
- the MS and/or the MSD analyses were not performed on a sample associated with a Laboratory request number,
- the RPD of the MS/MSD was greater than the acceptance criteria,
- the spike percent recovery value was greater than 10%,
- the initial calibration y-intercept criteria were not met, or
- other QC failure.

Furans: The sample result was greater than the EQL and less than or equal to 5 times the concentration of the related analyte in the blank or other quality control failure.

A total of 5332 inorganic chemical results were reported as estimated, either detected or not detected. Results that were estimated were caused by either

- the spike recovery value was greater than or equal to the UAL (125%) but less than or equal to 150%,

- the spike percent recovery value was greater than 30% and less than the LAL (75%),
- the spike percent recovery value is less than 30%,
- the analyte was identified in the method blank,
- the sample result was less than the estimated detection limit,
- the holding time was exceeded,
- the extraction holding time was exceeded by 2 times the acceptable holding time,
- the duplicate sample RPD was greater than the advisory limit,
- the duplicate sample analysis was not performed on a sample associated with the same request number,
- the MS analysis was not performed on a sample associated with the same request number,
- the RPD was greater than 10% in the serial dilution sample,
- the serial dilution sample RPD was greater than 10% and the sample result was greater than 50 times the MDL,
- negative blank sample results were greater than the MDL,
- the RL verification recovery was greater than the acceptance criteria,
- the result was less than the practical quantitation limit but greater than the MDL,
- an applicable MS/MSD analysis was not performed,
- the MS/MSD percent recovery was too high, or
- other QC failure.

A total of 1444 radionuclide results were estimated because

- the MS percent recovery was less than 10%,
- the MS percent recovery is less than the lower limit and the sample result is less than the minimum detectable activity,
- the method blank information is missing,
- the duplicate and sample results have a duplicate error ratio that is greater than 2.0,
- the result values are less than 3 times the minimum detectable concentration,
- the tracer percent recovery is greater than 125%,
- the MS analysis was not performed on a sample associated with this request number,
- the tracer percent recovery is between 10% and 30%,

- recovery of the analyte in the LCS is less than the lower limit and the analyte is greater than the minimum detectable activity,
- the tracer percent recovery was less than 10%,
- the MS percent recovery was greater than the upper limit and the sample result was greater than the MDA, or
- the recovery of the analyte in the LCS was greater than the upper limit and the analyte result was greater than the minimum detectable activity.

A total of 12,193 organic chemical results were reported as estimated, either detected or not detected, based on the following issues:

Volatiles: Volatile chemical results were estimated because

- the sample result was less than or equal to 5 times the concentration of the related analyte in the method blank,
- the analyte was analyzed with an initial calibration curve that exceeded the percent RSD criteria and/or a continuing calibration standard that exceeded the percent difference criteria,
- the affected analytes were analyzed with a relative response factor of less than 0.05,
- the ICV and/or CCV were outside the method-specific criteria,
- the analytical and/or extraction holding time was exceeded,
- the RPD of the MS/MSD was greater than the acceptance criteria,
- the spike percent recovery was greater than 10% and less than the LAL,
- the calibration verification percent difference was greater than the acceptance criteria but less than 60% or
- other QC failure.

Semivolatiles: Semivolatile chemical results were estimated because

- two or more surrogates were greater than or equal to 10% recovery but less than the LAL,
- the affected analytes were analyzed with an initial calibration curve that exceeded the percent RSD criteria and/or a continuing calibration standard that exceeded the percent difference criteria,
- the affected analytes were analyzed with a relative response factor of less than 0.05,
- the ICV/CCV were recovered outside the method-specific limits,
- the LCS percent recovery was less than the LAL but greater than 10%,
- the required calibration information was missing or samples were analyzed on an expired calibration,
- the RPD of the MS/MSD was greater than the acceptance criteria,

- the spike percent recovery value was greater than 10% and less than the LAL,
- the calibration percent RSD was greater than the acceptance criteria but less than 60%,
- the calibration verification percent difference was greater than the acceptance criteria but less than 60%,
- the LCS recovery was greater than the acceptance criteria, or
- other QC issue.

Pesticides/PCBs: Pesticide and PCB results were estimated because

- the surrogate was recovered greater than 10% but less than the LAL,
- the result was less than the EQL and the surrogate percent recovery was greater than 10% but less than the LAL,
- the ICV/CCV were recovered outside the method-specific limits,
- the holding time was exceeded,
- the LCS analyte was recovered less than 10%,
- the LCS analyte was recovered greater than 10% but less than the LAL,
- the RPD of the MS/MSD was greater than the acceptance criteria, or
- the spike percent recovery was greater than 10% and less than the LAL.

High Explosives: High explosives results were estimated because

- The surrogate percent recovery was less than the LAL but greater than 10%,
- the sample result was greater than the EQL and less than 5 times the concentration in the blank,
- the method blank data was missing or a method blank was not analyzed,
- the recovery of the LCS analyte was greater than LAL,
- the LCS analyte percent recovery was less than the LAL and greater than or equal to 10%,
- the holding time was exceeded,
- the LCS percent recovery was less than the LAL but greater than 10%,
- insufficient sample volume was received for an MS and/or MSD analyses,
- the MS and/or MSD analyses were not performed on a sample associated with a Laboratory request number,
- the RPD of the MS/MSD was greater than the acceptance criteria,
- the spike percent recovery was greater than or equal to the UAL,
- the spike recovery value was greater than 10% and less than the LAL,

- the MS/MSD percent recovery was greater than 10% but less than 70%,
- the affected analyte was analyzed with a relative response factor of less than 0.05 in the ICV and/or CCV,
- the ICV and/or CCV were recovered outside the method limits,
- the result was less than the practical quantitation limit but greater than the MDL,
- the CCV was outside acceptance limits,
- the MS/MSD recovery was outside acceptance limits,
- the LCS was outside acceptance limits,
- the initial calibration slope or response factor criteria were not met,
- an applicable MS/MSD analysis was not performed,
- the RPD of the MS/MSD is greater than the acceptance criteria or the recoveries were outside acceptance limits, or
- other quality control failures.

Herbicides: The spike percent recovery was greater than 10% and less than the LAL or the RPD of the MS/MSD was greater than the acceptance criteria.

Diesel Range Organics: The sample temperature was elevated.

Dioxin/Furan: The continuing calibration verification was outside acceptance limits, the relative percent difference of the MS/MSD was greater than the acceptance criteria or other QC failure.

C-8.3 Core Data

C-8.3-1 Alluvial Well Core Data

Samples of alluvial core were collected in Pajarito Canyon during the drilling of alluvial wells. A total of 2097 results from alluvial well core samples were reported. Of these results, 21 results were rejected during data validation. These rejected results represent about 1% of all the alluvial well core results.

Twenty inorganic chemical results, all perchlorate, were rejected because the result was not detected, and the extraction/analytical holding time was exceeded by less than 2 times the published method for holding times. One organic chemical result for tetryl was rejected because the LCS percent recovery was less than 10%.

Two hundred forty-seven inorganic chemical results, all metals, were reported as estimated, either detected or not detected. All metals results that were estimated were because either

- the sample and the duplicate sample results were less than 5 times the RL and the duplicate RPD was greater than 35%,
- the serial dilution sample RPD was greater than 10% and the sample result was greater than 50 times the MDL,

- the analyte was identified in the method blank but was greater than 5 times the amount in the method blank,
- the associated matrix spike recovery was less than the LAL but greater than 10%, or
- the associated MS recovery was greater than the LAL, or the analytical laboratory qualified the result as estimated.

Eighteen radionuclide results, all for either uranium-234 or uranium-238, were estimated because the associated duplicate sample had a duplicate error ratio or relative error ratio greater than the analytical laboratory's acceptance limits.

Fifty-one organic chemical results were reported as estimated, either detected or not detected, based on the following issues:

Volatiles: The ICV and/or CCV were recovered outside the method-specific limits.

PCBs: The analytical laboratory qualified the result as estimated.

High Explosives: The LCS percent recovery was less than the LAL but greater than 10%, or the ICV and/or CCV was recovered outside the method-specific limits.

C-8.3-2 Regional Well Core Data

Core samples were collected in Pajarito Canyon during the drilling of regional wells. A total of 946 results from regional well core samples were reported. Of these results, 29 results were rejected during data validation. These rejected results represent about 3% of all the regional well core results.

Seven inorganic chemical results, all antimony, were rejected because the spike percent recovery was less than 30%. Twenty-two radionuclide results were rejected because the tracer percent recovery was between 10% and 30% and the result was greater than the minimum detectable activity or spectral interference prevented positive identification of the analyte.

One hundred thirty-seven inorganic chemical results, all metals, were reported as estimated, either detected or not detected. All metals results that were estimated were because either

- the sample result was reported as detected between the instrument detection limit and the estimated detection limit,
- the duplicate sample was not prepared and/or analyzed with the samples for unspecified reasons,
- the duplicate information was missing, or
- the associated matrix spike recovery was less than the LAL but greater than 10%.

Thirty-two radionuclide results were estimated because the tracer percent recovery was between 10% and 30%, or the associated LCS was less than the LAL but greater than 10%.

C-8.4 Biota Data

Biota samples were collected in Pajarito Canyon. A total of 517 results from biota samples in this canyon were reported. Biota samples include eggs, insects, and worms. There were no results rejected during data validation.

C-8.4-1 Eggs

Fifty-two inorganic chemical results were reported as estimated, either detected or not detected. Results were estimated because the results were between the estimated quantization limit and the method detection limit, the results are less than 5 times the amount in the preparation blank, a serial dilution sample was not analyzed with the samples, or the laboratory reported the result as estimated.

C-8.4-2 Insects

One hundred inorganic chemical results were reported as estimated, either detected or not detected, because

- the results are less than 5 times the amount in the preparation blank,
- the results are less than 5 times the amount in the associated ICB or CCB,
- either the sample or duplicate sample results or both were greater than or equal to 5 times the RL or
- the difference between the samples is greater than 2 times the RL for soil samples.

C-8.4-3 Worms

Forty-three detected results were reported as estimated. Thirty-two inorganic chemical results were estimated because

- the results are less than 5 times the amount in the preparation blank,
- either the sample or duplicate sample results or both were greater than or equal to 5 times the RL,
- the difference between the samples is greater than the RL for 2 times the RL for soil samples.

One PCB result and 10 perchlorate results were reported by the laboratory as estimated.

C-9.0 REFERENCES

The following list includes all documents cited in this appendix. Parenthetical information following each reference provides the author(s), publication date, and ER ID number. This information is also included in text citations. ER ID numbers are assigned by the Environmental Programs Directorate's Records Processing Facility (RPF) and are used to locate the document at the RPF and, where applicable, in the master reference set.

Copies of the master reference set are maintained at the New Mexico Environment Department Hazardous Waste Bureau; the U.S. Department of Energy—Los Alamos Site Office; the EPA, Region 6; and the Directorate. The set was developed to ensure that the administrative authority has all material needed to review this document, and it is updated with every document submitted to the administrative authority. Documents previously submitted to the administrative authority are not included.

EPA (U.S. Environmental Protection Agency), February 1994. "USEPA Contract Laboratory Program National Functional Guidelines for Inorganic Data Review," EPA-540/R-94/013, Office of Emergency and Remedial Response, Washington, D.C. (EPA 1994, 048639)

EPA (U.S. Environmental Protection Agency), October 1999. "USEPA Contract Laboratory Program National Functional Guidelines for Organic Data Review," EPA540/R-99/008, Office of Emergency and Remedial Response, Washington, D.C. (EPA 1999, 066649)

LANL (Los Alamos National Laboratory), July 1995. "Statement of Work (Formerly Called "Requirements Document") - Analytical Support, (RFP number 9-XS1-Q4257), (Revision 2 - July, 1995)," Los Alamos National Laboratory, Los Alamos, New Mexico. (LANL 1995, 049738)

LANL (Los Alamos National Laboratory), March 1996. "Quality Assurance Project Plan Requirements for Sampling and Analysis," Los Alamos National Laboratory document LA-UR-96-441, Los Alamos, New Mexico. (LANL 1996, 054609)

LANL (Los Alamos National Laboratory), September 22, 1998. "Inorganic and Radionuclide Background Data for Soils, Canyon Sediments, and Bandelier Tuff at Los Alamos National Laboratory," Los Alamos National Laboratory document LA-UR-98-4847, Los Alamos, New Mexico. (LANL 1998, 059730)

LANL (Los Alamos National Laboratory), December 2000. "University of California, Los Alamos National Laboratory (LANL), I8980SOW0-8S, Statement of Work for Analytical Laboratories," Rev. 1, Los Alamos National Laboratory, Los Alamos, New Mexico. (LANL 2000, 071233)

**Table C-2.0-1
Pajarito Canyon Watershed Sediment Samples Collected**

Reach	Location ID	Top Depth (cm)	Bottom Depth (cm)	Sample ID	Media Code	Field Code	Collection Date	Geomorphic Unit	Am-241	Anion	CN	Dioxin/Furan	Gamma Spec	H3	HEXP	Iso Pu	Iso Th	Iso U	Metals	PAH	PCB	Perchlorate	PEST	pH	Sr-90	SVOC	VOC	Wet Chem
AEN-1	PA-24865	0	16	CAPA-05-61651	SED	- ^b	7/13/2005	c2	x ^a	-	x	-	x	x	x	x	x	x	x	x	x	x	x	x	x	x	x	x
AEN-1	PA-24865	16	39	CAPA-05-61652	SED	-	7/13/2005	c2	x	-	x	-	x	x	x	x	x	x	x	x	x	x	x	x	x	x	x	x
AEN-1	PA-24867	0	30	CAPA-05-61653	SED	-	7/13/2005	f2	x	-	x	-	x	x	x	x	x	x	x	x	x	x	x	x	x	x	x	x
AEN-1	PA-24868	0	25	CAPA-05-61654	SED	-	7/13/2005	c2	x	-	x	-	x	x	x	x	x	x	x	x	x	x	x	x	x	x	x	x
AEN-1	PA-24869	0	25	CAPA-05-61655	SED	-	7/13/2005	c2	x	-	x	-	x	x	x	x	x	x	x	x	x	x	x	x	x	x	x	x
AEN-1	PA-24869	0	25	CAPA-05-61666	SED	Field Duplicate	7/13/2005	c2	x	-	x	-	x	x	x	x	x	x	x	x	x	x	x	-	x	x	x	-
AEN-1	PA-24870	0	10	CAPA-05-61656	SED	-	7/13/2005	c1	x	-	x	-	x	x	x	x	x	x	x	x	x	x	x	x	x	x	x	x
AEN-1	PA-24871	0	30	CAPA-08-8446	SED	-	11/7/2007	f1	-	x	x	-	-	-	-	-	-	-	x	x	x	x	x	-	-	x	-	-
AEN-1	PA-24871	4	21	CAPA-05-61657	SED	-	7/13/2005	f1	x	-	x	-	x	x	x	x	x	x	x	x	x	x	x	x	x	x	x	x
AEN-1	PA-24872	3	19	CAPA-05-61658	SED	-	7/13/2005	f1	x	-	x	-	x	x	x	x	x	x	x	x	x	x	x	x	x	x	x	x
AEN-1	PA-24873	0	16	CAPA-05-61659	SED	-	7/13/2005	f1	x	-	x	-	x	x	x	x	x	x	x	x	x	x	x	x	x	x	x	x
AEN-1	PA-24874	0	14	CAPA-05-61660	SED	-	7/13/2005	c2	x	-	x	-	x	x	x	x	x	x	x	x	x	x	x	x	x	x	x	x
AES-1	PA-24855	0	16	CAPA-05-61641	SED	-	7/13/2005	c2	x	-	x	-	x	x	x	x	x	x	x	x	x	x	x	x	x	x	x	x
AES-1	PA-24855	16	40	CAPA-05-61642	SED	-	7/13/2005	c2	x	-	x	-	x	x	x	x	x	x	x	x	x	x	x	x	x	x	x	x
AES-1	PA-24857	0	26	CAPA-05-61643	SED	-	7/13/2005	c2	x	-	x	-	x	x	x	x	x	x	x	x	x	x	x	x	x	x	x	x
AES-1	PA-24857	26	63	CAPA-05-61644	SED	-	7/13/2005	c2	x	-	x	-	x	x	x	x	x	x	x	x	x	x	x	x	x	x	x	x
AES-1	PA-24859	0	35	CAPA-05-61645	SED	-	7/13/2005	f1	x	-	x	-	x	x	x	x	x	x	x	x	x	x	x	x	x	x	x	x
AES-1	PA-24859	0	35	CAPA-05-61665	SED	Field Duplicate	7/13/2005	f1	x	-	x	-	x	x	x	x	x	x	x	x	x	x	x	-	x	x	x	-
AES-1	PA-24860	0	16	CAPA-05-61646	SED	-	7/13/2005	f1	x	-	x	-	x	x	x	x	x	x	x	x	x	x	x	x	x	x	x	x
AES-1	PA-24860	16	43	CAPA-05-61647	SED	-	7/13/2005	f1	x	-	x	-	x	x	x	x	x	x	x	x	x	x	x	x	x	x	x	x
AES-1	PA-24862	0	36	CAPA-05-61648	SED	-	7/13/2005	c1	x	-	x	-	x	x	x	x	x	x	x	x	x	x	x	x	x	x	x	x
AES-1	PA-24863	0	39	CAPA-05-61649	SED	-	7/13/2005	c2	x	-	x	-	x	x	x	x	x	x	x	x	x	x	x	x	x	x	x	x
AES-1	PA-24864	0	36	CAPA-05-61650	SED	-	7/13/2005	c2	x	-	x	-	x	x	x	x	x	x	x	x	x	x	x	x	x	x	x	x
AW-1	PA-26408	0	10	CAPA-06-70616	SED	-	5/12/2006	c1w	-	-	x	-	x	-	x	-	-	x	x	x	x	-	x	x	x	x	x	x
AW-1	PA-26408	17	33	CAPA-06-70617	SED	-	5/12/2006	c1w	-	-	x	-	x	-	x	-	-	x	x	x	x	-	x	x	x	x	x	x
AW-1	PA-26410	0	30	CAPA-08-8447	SED	-	11/6/2007	c2	-	x	x	-	-	-	-	-	-	-	x	x	x	x	x	-	-	x	-	-

Table C-2.0-1 (continued)

Reach	Location ID	Top Depth (cm)	Bottom Depth (cm)	Sample ID	Media Code	Field Code	Collection Date	Geomorphic Unit	Am-241	Anion	CN	Dioxin/Furan	Gamma Spec	H3	HEXP	Iso Pu	Iso Th	Iso U	Metals	PAH	PCB	Perchlorate	PEST	pH	Sr-90	SVOC	VOC	Wet Chem
AW-1	PA-26410	0	15	CAPA-06-70618	SED	-	5/12/2006	c2	-	-	x	-	x	-	x	-	x	x	x	x	x	-	x	x	x	x	x	x
AW-1	PA-26410	15	31	CAPA-06-70619	SED	-	5/12/2006	c2	-	-	x	-	x	-	x	-	x	x	x	x	x	-	x	x	x	x	x	x
AW-1	PA-26412	0	20	CAPA-06-70620	SED	-	5/12/2006	c2	-	-	x	-	x	-	x	-	x	x	x	x	x	-	x	x	x	x	x	x
AW-1	PA-26413	0	32	CAPA-06-70621	SED	-	5/12/2006	c2	-	-	x	-	x	-	x	-	x	x	x	x	x	-	x	x	x	x	x	x
AW-1	PA-26413	32	61	CAPA-07-4741	SED	-	8/1/2007	c2	-	-	-	-	-	-	-	-	-	-	x	x	x	-	-	-	-	x	-	-
AW-1	PA-26414	0	15	CAPA-06-70622	SED	-	5/12/2006	c1	-	-	x	-	x	-	x	-	x	x	x	x	x	-	x	x	x	x	x	x
AW-1	PA-26415	0	29	CAPA-06-70623	SED	-	5/12/2006	c2	-	-	x	-	x	-	x	-	x	x	x	x	x	-	x	x	x	x	x	x
AW-1	PA-26416	0	33	CAPA-06-70624	SED	-	5/12/2006	c2	-	-	x	-	x	-	x	-	x	x	x	x	x	-	x	x	x	x	x	x
AW-1	PA-26416	0	33	CAPA-06-70626	SED	Field Duplicate	5/12/2006	c2	-	-	x	-	x	-	-	-	-	x	x	x	x	-	x	-	x	x	x	-
AW-1	PA-26417	12	55	CAPA-06-70625	SED	-	5/12/2006	c2	-	-	x	-	x	-	x	-	x	x	x	x	x	-	x	x	x	x	x	x
AW-1	PA-601015	0	23	CAPA-07-4736	SED	-	8/1/2007	c1f	-	-	-	-	-	-	-	-	-	-	x	x	x	-	-	-	-	x	-	-
AW-1	PA-601016	0	17	CAPA-07-4737	SED	-	8/1/2007	c2	-	-	-	-	-	-	-	-	-	-	x	x	x	-	-	-	-	x	-	-
AW-1	PA-601017	0	22	CAPA-07-4738	SED	-	8/1/2007	c2	-	-	-	-	-	-	-	-	-	-	x	x	x	-	-	-	-	x	-	-
AW-1	PA-601018	0	13	CAPA-07-4739	SED	-	8/1/2007	c2	-	-	-	-	-	-	-	-	-	-	x	x	x	-	-	-	-	x	-	-
AW-1	PA-601019	0	25	CAPA-07-4740	SED	-	8/1/2007	c2	-	-	-	-	-	-	-	-	-	-	x	x	x	-	-	-	-	x	-	-
AW-1	PA-601021	0	8	CAPA-07-4742	SED	-	8/1/2007	c1	-	-	-	-	-	-	-	-	-	-	x	x	x	-	-	-	-	x	-	-
AW-1	PA-601022	0	13	CAPA-07-4743	SED	-	8/1/2007	c2	-	-	-	-	-	-	-	-	-	-	x	x	x	-	-	-	-	x	-	-
AW-1	PA-601022	13	52	CAPA-07-4744	SED	-	8/1/2007	c2	-	-	-	-	-	-	-	-	-	-	x	x	x	-	-	-	-	x	-	-
AW-1	PA-601024	0	23	CAPA-07-4745	SED	-	8/1/2007	c2	-	-	-	-	-	-	-	-	-	-	x	x	x	-	-	-	-	x	-	-
AW-1	PA-601024	0	23	CAPA-07-4746	SED	Field Duplicate	8/1/2007	c2	-	-	-	-	-	-	-	-	-	-	x	x	x	-	-	-	-	x	-	-
AW-1	PA-603101	0	15	CAPA-08-8452	SED	-	11/6/2007	c1	-	-	-	-	-	-	-	-	-	-	x	x	x	-	x	-	-	x	-	-
PA-0	18-10103	0	15	CA18-00-0042	SED	-	6/29/2000	c2? [f1?]	x	-	x	-	x	-	x	x	-	x	x	-	x	-	x	-	-	x	-	-
PA-0	PA-26497	37	54	CAPA-06-71046	SED	-	6/28/2006	c2+f1	x	-	x	-	x	x	x	x	-	x	x	x	x	x	x	-	-	x	x	x
PA-0	PA-26498	0	15	CAPA-06-71047	SED	-	6/28/2006	c2	x	-	x	-	x	x	x	x	-	x	x	x	x	x	x	-	-	x	x	x
PA-0	PA-26499	0	30	CAPA-06-71048	SED	-	6/28/2006	c1	x	-	x	-	x	x	x	x	-	x	x	x	x	x	x	-	-	x	x	x
PA-0	PA-26500	0	12	CAPA-06-71049	SED	-	6/28/2006	f1	x	-	x	-	x	x	x	x	-	x	x	x	x	x	x	-	-	x	x	x
PA-0	PA-26500	0	30	CAPA-08-8448	SED	-	11/7/2007	f1	-	x	x	-	-	-	-	-	-	-	x	x	x	x	x	-	-	x	-	-

Table C-2.0-1 (continued)

Reach	Location ID	Top Depth (cm)	Bottom Depth (cm)	Sample ID	Media Code	Field Code	Collection Date	Geomorphic Unit	Am-241	Anion	CN	Dioxin/Furan	Gamma Spec	H3	HEXP	Iso Pu	Iso Th	Iso U	Metals	PAH	PCB	Perchlorate	PEST	pH	Sr-90	SVOC	VOC	Wet Chem
PA-0	PA-26501	27	54	CAPA-06-71050	SED	-	6/28/2006	c2+f1	x	-	x	-	x	x	x	x	-	x	x	x	x	x	-	-	x	x	x	
PA-0	PA-26502	16	37	CAPA-06-71051	SED	-	6/28/2006	c2	x	-	x	-	x	x	x	x	-	x	x	x	x	x	x	-	-	x	x	x
PA-0	PA-26503	0	24	CAPA-06-71052	SED	-	6/28/2006	f1	x	-	x	-	x	x	x	x	-	x	x	x	x	x	x	-	-	x	x	x
PA-0	PA-26503	0	24	CAPA-06-71056	SED	Field Duplicate	6/28/2006	f1	x	-	x	-	x	x	x	x	-	x	x	x	x	x	x	-	-	x	x	-
PA-0	PA-26504	36	49	CAPA-06-71053	SED	-	6/28/2006	f1	x	-	x	-	x	x	x	x	-	x	x	x	x	x	x	-	-	x	x	x
PA-0	PA-26505	30	75	CAPA-06-71054	SED	-	6/28/2006	c2+f1	x	-	x	-	x	x	x	x	-	x	x	x	x	x	x	-	-	x	x	x
PA-0	PA-26506	3	38	CAPA-06-71055	SED	-	6/28/2006	c2+f1	x	-	x	-	x	x	x	x	-	x	x	x	x	x	x	-	-	x	x	x
PA-0	PA-603102	0	15	CAPA-08-8453	SED	-	11/7/2007	c1	-	-	-	-	-	-	-	-	-	-	x	x	x	-	x	-	-	x	-	-
PA-1E	18-10085	0	17	CA18-00-0021	SED	-	6/26/2000	c2	x	-	x	-	x	-	x	x	-	x	x	-	x	-	x	-	-	x	-	-
PA-1E	18-10086	0	12	CAPA-06-71127	SED	-	6/13/2006	f1? [c3?]	x	-	x	-	x	x	x	x	-	x	x	x	x	x	x	-	-	x	x	x
PA-1E	18-10086	0	12	CAPA-06-71137	SED	Field Duplicate	6/13/2006	f1? [c3?]	x	-	x	-	x	x	x	x	-	x	x	x	x	x	x	-	-	x	x	-
PA-1E	18-10086	0	25	CA18-00-0022	SED	-	6/26/2000	c3? [f1?]	x	-	x	-	x	-	x	x	-	x	x	-	x	-	x	-	-	x	-	-
PA-1E	18-10086	12	37	CAPA-06-71135	SED	-	6/13/2006	f1? [c3?]	-	-	-	-	-	x	x	-	-	-	-	x	-	x	-	-	-	-	x	x
PA-1E	18-10087	13	25	CA18-00-0023	SED	-	6/26/2000	c2	x	-	x	-	x	-	x	x	-	x	x	-	x	-	x	-	-	x	-	-
PA-1E	18-10088	0	13	CA18-00-0024	SED	-	6/26/2000	f1? [f2?]	x	-	x	-	x	-	x	x	-	x	x	-	x	-	x	-	-	x	-	-
PA-1E	18-10088	21	34	CAPA-06-71136	SED	-	6/13/2006	f1	-	-	-	-	-	x	x	-	-	-	-	x	-	x	-	-	-	-	x	x
PA-1E	18-10089	0	23	CA18-00-0025	SED	-	6/26/2000	c2	x	-	x	-	x	-	x	x	-	x	x	-	x	-	x	-	-	x	-	-
PA-1E	18-10090	0	23	CA18-00-0026	SED	-	6/26/2000	c2	x	-	x	-	x	-	x	x	-	x	x	-	x	-	x	-	-	x	-	-
PA-1E	PA-26562	46	73	CAPA-06-71128	SED	-	6/13/2006	c2	x	-	x	-	x	x	x	x	-	x	x	x	x	x	x	-	-	x	x	x
PA-1E	PA-26563	0	20	CAPA-06-71129	SED	-	6/13/2006	c1	x	-	x	-	x	x	x	x	-	x	x	x	x	x	x	-	-	x	x	x
PA-1E	PA-26564	4	20	CAPA-06-71130	SED	-	6/13/2006	c2? [f1?]	x	-	x	-	x	x	x	x	-	x	x	x	x	x	x	-	-	x	x	x
PA-1E	PA-26564	20	34	CAPA-06-71131	SED	-	6/13/2006	c2? [f1?]	x	-	x	-	x	x	x	x	-	x	x	x	x	x	x	-	-	x	x	x
PA-1E	PA-26566	0	25	CAPA-06-71132	SED	-	6/13/2006	c1	x	-	x	-	x	x	x	x	-	x	x	x	x	x	x	-	-	x	x	x
PA-1E	PA-26567	12	24	CAPA-06-71133	SED	-	6/13/2006	c2	x	-	x	-	x	x	x	x	-	x	x	x	x	x	x	-	-	x	x	x
PA-1E	PA-26567	24	48	CAPA-06-71134	SED	-	6/13/2006	c2	x	-	x	-	x	x	x	x	-	x	x	x	x	x	x	-	-	x	x	x
PA-1E	PA-603098	0	30	CAPA-08-8449	SED	-	11/6/2007	c2	-	x	x	-	-	-	-	-	-	-	-	x	x	x	x	-	-	x	-	-

Table C-2.0-1 (continued)

Reach	Location ID	Top Depth (cm)	Bottom Depth (cm)	Sample ID	Media Code	Field Code	Collection Date	Geomorphic Unit	Am-241	Anion	CN	Dioxin/Furan	Gamma Spec	H3	HEXP	Iso Pu	Iso Th	Iso U	Metals	PAH	PCB	Perchlorate	PEST	pH	Sr-90	SVOC	VOC	Wet Chem
PA-1E	PA-603098	0	30	CAPA-08-8456	SED	Field Duplicate	11/6/2007	c2	-	-	x	-	-	-	-	-	-	-	x	x	x	x	x	-	-	x	-	x
PA-1W	PA-26511	0	30	CAPA-06-71063	SED	-	5/25/2006	c1	x	-	x	-	x	x	x	x	-	x	x	x	x	x	x	x	-	x	x	x
PA-1W	PA-26512	7	34	CAPA-06-71064	SED	-	5/25/2006	c2	x	-	x	-	x	x	x	x	-	x	x	x	x	x	x	x	-	x	x	x
PA-1W	PA-26513	0	40	CAPA-06-71065	SED	-	5/25/2006	c2	x	-	x	-	x	x	x	x	-	x	x	x	x	x	x	x	-	x	x	x
PA-1W	PA-26513	40	65	CAPA-06-71066	SED	-	5/25/2006	c2	x	-	x	-	x	x	x	x	-	x	x	x	x	x	x	x	-	x	x	x
PA-1W	PA-26515	4	33	CAPA-06-71067	SED	-	5/25/2006	f1? [c3?]	x	-	x	-	x	x	x	x	-	x	x	-	x	x	x	x	-	x	x	x
PA-1W	PA-26516	0	28	CAPA-06-71068	SED	-	5/25/2006	f1	x	-	x	-	x	x	x	x	-	x	x	-	x	x	x	x	-	x	x	x
PA-1W	PA-26516	0	28	CAPA-06-71073	SED	Field Duplicate	5/25/2006	f1	x	-	x	-	x	x	-	x	-	x	x	x	x	x	x	-	-	x	x	-
PA-1W	PA-26517	0	30	CAPA-06-71069	SED	-	5/25/2006	c1	x	-	x	-	x	x	x	x	-	x	x	x	x	x	x	x	-	x	x	x
PA-1W	PA-26518	9	34	CAPA-06-71070	SED	-	5/25/2006	f1? [c3?]	x	-	x	-	x	x	x	x	-	x	x	x	x	x	x	x	-	x	x	x
PA-1W	PA-26519	0	14	CAPA-06-71071	SED	-	5/25/2006	c2	x	-	x	-	x	x	x	x	-	x	x	x	x	x	x	x	-	x	x	x
PA-1W	PA-26519	14	42	CAPA-06-71072	SED	-	5/25/2006	c2	x	-	x	-	x	x	x	x	-	x	x	x	x	x	x	x	-	x	x	x
PA-2W	18-10091	0	31	CA18-00-0027	SED	-	6/27/2000	f1	x	-	x	-	x	-	x	x	-	x	x	-	x	-	x	-	-	x	-	-
PA-2W	18-10092	0	16	CA18-00-0028	SED	-	6/27/2000	c2	x	-	x	-	x	-	x	x	-	x	x	-	x	-	x	-	-	x	-	-
PA-2W	18-10093	0	10	CA18-00-0029	SED	-	6/27/2000	c2	x	-	x	-	x	-	x	x	-	x	x	-	x	-	x	-	-	x	-	-
PA-2W	18-10094	0	19	CA18-00-0030	SED	-	6/27/2000	c2	x	-	x	-	x	-	x	x	-	x	x	-	x	-	x	-	-	x	-	-
PA-2W	18-10094	0	18	CAPA-05-62725	SED	-	7/28/2005	c2	-	-	-	-	-	x	x	-	x	-	-	x	-	x	-	x	x	-	x	x
PA-2W	18-10094	18	30	CAPA-05-62726	SED	-	7/28/2005	c2	-	-	-	-	-	x	x	-	x	-	-	x	-	x	-	x	x	-	x	x
PA-2W	18-10094	19	31	CA18-00-0031	SED	-	6/27/2000	c2	x	-	x	-	x	-	x	x	-	x	x	-	x	-	x	-	-	x	-	-
PA-2W	18-10095	13	37	CA18-00-0032	SED	-	6/27/2000	c2	x	-	x	-	x	-	x	x	-	x	x	-	x	-	x	-	-	x	-	-
PA-2W	PA-24986	0	27	CAPA-05-62706	SED	-	7/28/2005	c2	x	-	x	-	x	x	x	x	x	x	x	x	x	x	x	x	x	x	x	x
PA-2W	PA-24987	0	6	CAPA-05-62707	SED	-	7/28/2005	f2	x	-	x	-	x	x	x	x	x	x	x	x	x	x	x	x	x	x	x	x
PA-2W	PA-24988	0	14	CAPA-05-62708	SED	-	7/28/2005	f1	x	-	x	-	x	x	x	x	x	x	x	x	x	x	x	x	x	x	x	x
PA-2W	PA-24989	22	42	CAPA-05-62709	SED	-	7/28/2005	c2	x	-	x	-	x	x	x	x	x	x	x	x	x	x	x	x	x	x	x	x
PA-2W	PA-24990	11	31	CAPA-05-62710	SED	-	7/28/2005	f1	x	-	x	-	x	x	x	x	x	x	x	x	x	x	x	x	x	x	x	x
PA-2W	PA-24991	15	29	CAPA-05-62711	SED	-	7/28/2005	f1	x	-	x	-	x	x	x	x	x	x	x	x	x	x	x	x	x	x	x	x
PA-2W	PA-24992	0	30	CAPA-05-62712	SED	-	7/28/2005	c2	x	-	x	-	x	x	x	x	x	x	x	x	x	x	x	x	x	x	x	x

Table C-2.0-1 (continued)

Reach	Location ID	Top Depth (cm)	Bottom Depth (cm)	Sample ID	Media Code	Field Code	Collection Date	Geomorphic Unit	Am-241	Anion	CN	Dioxin/Furan	Gamma Spec	H3	HEXP	Iso Pu	Iso Th	Iso U	Metals	PAH	PCB	Perchlorate	PEST	pH	Sr-90	SVOC	VOC	Wet Chem
PA-2W	PA-24992	0	30	CAPA-05-62704	SED	Field Duplicate	7/28/2005	c2	x	-	x	-	x	x	x	x	x	x	x	x	x	x	-	x	x	x	x	-
PA-2W	PA-24993	0	10	CAPA-05-62713	SED	-	7/28/2005	c1	x	-	x	-	x	x	x	x	x	x	x	x	x	x	x	x	x	x	x	x
PA-2W	PA-26507	0	4	CAPA-06-71059	SED	-	6/14/2006	f2	x	-	x	-	x	x	x	x	-	x	x	x	x	x	-	-	x	x	x	
PA-2W	PA-26508	0	15	CAPA-06-71060	SED	-	6/14/2006	c1	x	-	x	-	x	x	x	x	-	x	x	x	x	x	-	-	x	x	x	
PA-2W	PA-601025	0	13	CAPA-07-4751	SED	-	8/1/2007	f2	x	-	-	-	x	x	x	x	-	x	x	x	x	x	-	x	x	x	x	
PA-2W	PA-601026	0	16	CAPA-07-4752	SED	-	8/1/2007	f1 swale	x	-	-	-	x	x	x	x	-	x	x	x	x	x	-	x	x	x	x	
PA-2W	PA-601026	0	16	CAPA-07-4747	SED	Field Duplicate	8/1/2007	f1 swale	x	-	-	-	x	x	x	x	-	x	x	x	x	x	-	x	x	x	x	
PA-3E	PA-24995	4	21	CAPA-05-62715	SED	-	8/17/2005	f1	x	-	x	-	x	x	x	x	x	x	x	x	x	x	x	x	x	x	x	x
PA-3E	PA-24996	4	30	CAPA-05-62716	SED	-	8/17/2005	c2	x	-	x	-	x	x	x	x	x	x	x	x	x	x	x	x	x	x	x	x
PA-3E	PA-24997	0	25	CAPA-05-62717	SED	-	8/17/2005	f2	x	-	x	-	x	x	x	x	x	x	x	x	x	x	x	x	x	x	x	x
PA-3E	PA-24997	0	25	CAPA-05-62731	SED	Field Duplicate	8/17/2005	f2	x	-	x	-	x	x	x	x	x	x	x	x	x	x	-	x	x	x	-	
PA-3E	PA-24998	12	35	CAPA-05-62718	SED	-	8/17/2005	c2	x	-	x	-	x	x	x	x	x	x	x	x	x	x	x	x	x	x	x	x
PA-3E	PA-24999	1	27	CAPA-05-62719	SED	-	8/17/2005	c2	x	-	x	-	x	x	x	x	x	x	x	x	x	x	x	x	x	x	x	x
PA-3E	PA-25000	0	5	CAPA-05-62720	SED	-	8/16/2005	c1	x	-	x	-	x	x	x	x	x	x	x	x	x	x	x	x	x	x	x	x
PA-3E	PA-25001	0	25	CAPA-05-62721	SED	-	8/17/2005	c2	x	-	x	-	x	x	x	x	x	x	x	x	x	x	x	x	x	x	x	x
PA-3E	PA-25001	46	71	CAPA-05-62722	SED	-	8/17/2005	c2	x	-	x	-	x	x	x	x	x	x	x	x	x	x	x	x	x	x	x	x
PA-3E	PA-25003	0	18	CAPA-05-62723	SED	-	8/17/2005	f1w	x	-	x	-	x	x	x	x	x	x	x	x	x	x	x	x	x	x	x	x
PA-3E	PA-25004	8	26	CAPA-05-62724	SED	-	8/17/2005	f1w	x	-	x	-	x	x	x	x	x	x	x	x	x	x	x	x	x	x	x	x
PA-3E	PA-601027	0	4	CAPA-07-4753	SED	-	8/1/2007	f1w	x	-	-	x	x	x	x	x	-	x	x	x	x	x	-	x	x	x	x	
PA-3E	PA-601028	0	12	CAPA-07-4756	SED	-	8/1/2007	c2	x	-	-	x	x	x	x	x	-	x	x	x	x	x	-	x	x	x	x	
PA-4	18-10096	0	9	CA18-00-0033	SED	-	7/5/2000	c1 willow	x	-	x	-	x	-	x	x	-	x	x	-	x	-	x	-	-	x	-	-
PA-4	18-10096	0	9	CAPA-05-63160	SED	-	8/16/2005	c1 willow	-	-	-	-	-	-	x	-	-	-	-	-	-	-	-	-	-	x	-	
PA-4	18-10097	1	15	CA18-00-0034	SED	-	7/5/2000	c1	x	-	x	-	x	-	x	x	-	x	x	-	x	-	x	-	-	x	-	-
PA-4	18-10098	8	20	CA18-00-0035	SED	-	7/5/2000	c2	x	-	x	-	x	-	x	x	-	x	x	-	x	-	x	-	-	x	-	-
PA-4	18-10098	8	20	CAPA-05-63161	SED	-	8/16/2005	c2	-	-	-	-	-	-	x	-	-	-	-	-	-	-	-	-	-	-	x	-
PA-4	PA-22882	9	39	CAPA-04-53801	SED	-	9/15/2004	c2	x	x	x	-	x	x	x	x	x	x	x	x	x	-	x	x	x	x	-	-

Table C-2.0-1 (continued)

Reach	Location ID	Top Depth (cm)	Bottom Depth (cm)	Sample ID	Media Code	Field Code	Collection Date	Geomorphic Unit	Am-241	Anion	CN	Dioxin/Furan	Gamma Spec	H3	HEXP	Iso Pu	Iso Th	Iso U	Metals	PAH	PCB	Perchlorate	PEST	pH	Sr-90	SVOC	VOC	Wet Chem
PA-4	PA-22882	9	39	CAPA-05-63152	SED	-	8/16/2005	c2	-	-	-	-	-	-	x	-	-	-	-	-	-	-	-	-	-	-	x	-
PA-4	PA-22883	0	14	CAPA-04-53802	SED	-	9/15/2004	c1w	x	x	x	-	x	x	x	x	x	x	x	x	x	-	x	x	x	x	-	-
PA-4	PA-22883	0	14	CAPA-05-63153	SED	-	8/16/2005	c1w	-	-	-	-	-	-	x	-	-	-	-	-	-	-	-	-	-	-	x	-
PA-4	PA-22884	14	24	CAPA-04-53803	SED	-	9/15/2004	c1w	x	x	x	-	x	x	x	x	x	x	x	x	x	-	x	x	x	x	-	-
PA-4	PA-22884	14	24	CAPA-05-63154	SED	-	8/16/2005	c1w	-	-	-	-	-	-	x	-	-	-	-	-	-	-	-	-	-	-	x	-
PA-4	PA-22884	24	32	CAPA-04-53804	SED	-	9/15/2004	c1w	x	x	x	-	x	x	x	x	x	x	x	x	x	-	x	x	x	x	-	-
PA-4	PA-22884	24	32	CAPA-05-63155	SED	-	8/16/2005	c1w	-	-	-	-	-	-	x	-	-	-	-	-	-	-	-	-	-	-	x	-
PA-4	PA-22884	32	56	CAPA-04-53805	SED	-	9/15/2004	c1w	x	x	x	-	x	x	x	x	x	x	x	x	x	-	x	x	x	x	-	-
PA-4	PA-22884	32	56	CAPA-04-53811	SED	Field Duplicate	9/15/2004	c1w	x	x	x	-	x	x	x	x	x	x	x	x	x	-	x	-	x	x	-	-
PA-4	PA-22884	32	56	CAPA-05-63156	SED	-	8/16/2005	c1w	-	-	-	-	-	-	x	-	-	-	-	-	-	-	-	-	-	-	x	-
PA-4	PA-22887	2	19	CAPA-04-53806	SED	-	9/15/2004	c1w	x	x	x	-	x	x	x	x	x	x	x	x	x	-	x	x	x	x	-	-
PA-4	PA-22887	2	19	CAPA-05-63162	SED	Field Duplicate	8/16/2005	c1w	-	-	-	-	-	-	x	-	-	-	-	-	-	-	-	-	-	-	x	-
PA-4	PA-22887	2	19	CAPA-05-63157	SED	-	8/16/2005	c1w	-	-	-	-	-	-	x	-	-	-	-	-	-	-	-	-	-	-	x	-
PA-4	PA-22887	19	27	CAPA-04-53807	SED	-	9/15/2004	c1w	x	x	x	-	x	x	x	x	x	x	x	x	x	-	x	x	x	x	-	-
PA-4	PA-22887	19	27	CAPA-05-63158	SED	-	8/16/2005	c1w	-	-	-	-	-	-	x	-	-	-	-	-	-	-	-	-	-	-	x	-
PA-4	PA-22889	4	18	CAPA-04-53808	SED	-	9/15/2004	c2	x	x	x	-	x	x	x	x	x	x	x	x	x	-	x	x	x	x	-	-
PA-4	PA-22889	4	18	CAPA-05-63159	SED	-	8/16/2005	c2	-	-	-	-	-	-	x	-	-	-	-	-	-	-	-	-	-	-	x	-
PA-4	PA-22890	0	26	CAPA-04-53809	SED	-	9/15/2004	c1 pool	x	x	x	-	x	x	x	x	x	x	x	x	x	-	x	x	x	x	-	-
PA-4	PA-22890	0	30	CAPA-08-8450	SED	-	11/6/2007	c1 pool	-	x	x	-	-	-	-	-	-	-	x	x	x	x	x	-	-	x	-	-
PA-4	PA-22890	26	35	CAPA-04-53810	SED	-	9/15/2004	c1 pool	x	x	x	-	x	x	x	x	x	x	x	x	x	-	x	x	x	x	-	-
PA-4	PA-603103	0	15	CAPA-08-8454	SED	-	11/6/2007	c1	-	-	-	-	-	-	-	-	-	-	x	x	x	-	x	-	-	x	-	-
PA-4E	18-10099	0	36	CA18-00-0036	SED	-	7/5/2000	f1? [c3?]	x	-	x	-	x	-	x	x	-	x	x	-	x	-	x	-	-	x	-	-
PA-4E	18-10099	0	36	CA18-00-0040	SED	Field Duplicate	7/5/2000	f1? [c3?]	x	-	x	-	x	-	x	x	-	x	x	-	x	-	x	-	-	x	-	-
PA-4E	18-10100	4	21	CA18-00-0037	SED	-	7/5/2000	f1? [c2?]	x	-	x	-	x	-	x	x	-	x	x	-	x	-	x	-	-	x	-	-
PA-4E	18-10100	30	63	CA18-00-0038	SED	-	7/5/2000	f1? [c2?]	x	-	x	-	x	-	x	x	-	x	x	-	x	-	x	-	-	x	-	-
PA-4E	18-10101	5	32	CA18-00-0039	SED	-	7/5/2000	c2? [c1b?]	x	-	x	-	x	-	x	x	-	x	x	-	x	-	x	-	-	x	-	-

Table C-2.0-1 (continued)

Reach	Location ID	Top Depth (cm)	Bottom Depth (cm)	Sample ID	Media Code	Field Code	Collection Date	Geomorphic Unit	Am-241	Anion	CN	Dioxin/Furan	Gamma Spec	H3	HEXP	Iso Pu	Iso Th	Iso U	Metals	PAH	PCB	Perchlorate	PEST	pH	Sr-90	SVOC	VOC	Wet Chem
PA-4E	18-10102	0	15	CA18-00-0041	SED	-	6/29/2000	c1b?	x	-	x	-	x	-	x	x	-	x	x	-	x	-	x	-	-	x	-	-
PA-5W	PA-26541	0	14	CAPA-06-71101	SED	-	6/27/2006	c3? [f1?]	x	-	x	-	x	-	x	x	x	-	x	x	x	-	x	-	-	x	x	x
PA-5W	PA-26541	24	34	CAPA-06-71102	SED	-	6/27/2006	c3? [f1?]	x	-	x	-	x	-	x	x	x	-	x	x	x	-	x	-	-	x	x	x
PA-5W	PA-26543	0	10	CAPA-06-71103	SED	-	6/27/2006	c3? [f1?]	x	-	x	-	x	-	x	x	x	-	x	x	x	-	x	-	-	x	x	x
PA-5W	PA-26544	0	24	CAPA-06-71104	SED	-	6/27/2006	c3? [f1?]	x	-	x	-	x	-	x	x	x	-	x	x	x	-	x	-	-	x	x	x
PA-5W	PA-26545	0	40	CAPA-06-71105	SED	-	6/27/2006	c3	x	-	x	-	x	-	x	x	x	-	x	x	x	-	x	-	-	x	x	x
PA-5W	PA-26546	0	14	CAPA-06-71106	SED	-	6/27/2006	f1	x	-	x	-	x	-	x	x	x	-	x	x	x	-	x	-	-	x	x	x
PA-5W	PA-26547	0	10	CAPA-06-71107	SED	-	6/27/2006	c1	x	-	x	-	x	-	x	x	x	-	x	x	x	-	x	-	-	x	x	x
PA-5W	PA-26548	0	11	CAPA-06-71108	SED	-	6/27/2006	c1b? [f1 swale?]	x	-	x	-	x	-	x	x	x	-	x	x	x	-	x	-	-	x	x	x
PA-5W	PA-26549	0	16	CAPA-06-71109	SED	-	6/27/2006	f1	x	-	x	-	x	-	x	x	x	-	x	x	x	-	x	-	-	x	x	x
PA-5W	PA-26549	0	16	CAPA-06-71111	SED	Field Duplicate	6/27/2006	f1	x	-	x	-	x	-	x	x	x	-	x	x	x	-	x	-	-	x	x	-
PA-5W	PA-26550	4	24	CAPA-06-71110	SED	-	6/27/2006	c2	x	-	x	-	x	-	x	x	x	-	x	x	x	-	x	-	-	x	x	x
PAS-1E	PA-26418	0	30	CAPA-08-8451	SED	-	11/6/2007	c2	-	x	x	-	-	-	-	-	-	-	x	x	x	x	x	-	-	x	-	-
PAS-1E	PA-26418	0	20	CAPA-06-70629	SED	-	5/12/2006	c2	-	-	x	-	x	-	x	-	-	x	x	x	x	-	x	x	x	x	x	x
PAS-1E	PA-26418	20	42	CAPA-06-70630	SED	-	5/12/2006	c2	-	-	x	-	x	-	x	-	-	x	x	x	x	-	x	x	x	x	x	x
PAS-1E	PA-26418	42	73	CAPA-06-70631	SED	-	5/12/2006	c2	-	-	x	-	x	-	x	-	-	x	x	x	x	-	x	x	x	x	x	x
PAS-1E	PA-26421	0	22	CAPA-06-70632	SED	-	5/12/2006	c2	-	-	x	-	x	-	x	-	-	x	x	x	x	-	x	x	x	x	x	x
PAS-1E	PA-26421	23	43	CAPA-06-70633	SED	-	5/12/2006	c2	-	-	x	-	x	-	x	-	-	x	x	x	x	-	x	x	x	x	x	x
PAS-1E	PA-26423	0	10	CAPA-06-70634	SED	-	5/12/2006	f1	-	-	x	-	x	-	x	-	-	x	x	x	x	-	x	x	x	x	x	x
PAS-1E	PA-26424	5	30	CAPA-06-70635	SED	-	5/12/2006	c1	-	-	x	-	x	-	x	-	-	x	x	x	x	-	x	x	x	x	x	x
PAS-1E	PA-26425	0	30	CAPA-06-70636	SED	-	5/12/2006	c1	-	-	x	-	x	-	x	-	-	x	x	x	x	-	x	x	x	x	x	x
PAS-1E	PA-26425	0	30	CAPA-06-70639	SED	Field Duplicate	5/12/2006	c1	-	-	x	-	x	-	-	-	-	x	x	x	x	-	x	-	x	x	x	-
PAS-1E	PA-26426	0	41	CAPA-06-70637	SED	-	5/12/2006	c2	-	-	x	-	x	-	x	-	-	x	x	x	x	-	x	x	x	x	x	x
PAS-1E	PA-26427	0	26	CAPA-06-70638	SED	-	5/12/2006	c2? [f1?]	-	-	x	-	x	-	x	-	-	x	x	x	x	-	x	x	x	x	x	x
PAS-2E	PA-603104	0	15	CAPA-08-8455	SED	-	11/7/2007	c1	-	-	-	-	-	-	-	-	-	-	x	x	x	-	x	-	-	x	-	-
PAS-2W	PA-24845	0	22	CAPA-05-61631	SED	-	7/12/2005	c2	x	-	x	-	x	x	x	x	x	x	x	x	x	x	x	x	x	x	x	x

Table C-2.0-1 (continued)

Reach	Location ID	Top Depth (cm)	Bottom Depth (cm)	Sample ID	Media Code	Field Code	Collection Date	Geomorphic Unit	Am-241	Anion	CN	Dioxin/Furan	Gamma Spec	H3	HEXP	Iso Pu	Iso Th	Iso U	Metals	PAH	PCB	Perchlorate	PEST	pH	Sr-90	SVOC	VOC	Wet Chem
PAS-2W	PA-24845	0	22	CAPA-05-61664	SED	Field Duplicate	7/12/2005	c2	x	-	x	-	x	x	x	x	x	x	x	x	x	x	-	x	x	x	x	-
PAS-2W	PA-24846	0	20	CAPA-05-61632	SED	-	7/12/2005	f1	x	-	x	-	x	x	x	x	x	x	x	x	x	x	x	x	x	x	x	x
PAS-2W	PA-24847	0	14	CAPA-05-61633	SED	-	7/12/2005	c2	x	-	x	-	x	x	x	x	x	x	x	x	x	x	x	x	x	x	x	x
PAS-2W	PA-24847	14	67	CAPA-05-61634	SED	-	7/12/2005	c2	x	-	x	-	x	x	x	x	x	x	x	x	x	x	x	x	x	x	x	x
PAS-2W	PA-24849	9	35	CAPA-05-61635	SED	-	7/12/2005	c1	x	-	x	-	x	x	x	x	x	x	x	x	x	x	x	x	x	x	x	x
PAS-2W	PA-24850	0	24	CAPA-05-61636	SED	-	7/12/2005	f1	x	-	x	-	x	x	x	x	x	x	x	x	x	x	x	x	x	x	x	x
PAS-2W	PA-24850	24	44	CAPA-05-61637	SED	-	7/12/2005	f1	x	-	x	-	x	x	x	x	x	x	x	x	x	x	x	x	x	x	x	x
PAS-2W	PA-24852	0	22	CAPA-05-61638	SED	-	7/12/2005	c2	x	-	x	-	x	x	x	x	x	x	x	x	x	x	x	x	x	x	x	x
PAS-2W	PA-24853	0	37	CAPA-05-61639	SED	-	7/12/2005	f1	x	-	x	-	x	x	x	x	x	x	x	x	x	x	x	x	x	x	x	x
PAS-2W	PA-24854	0	16	CAPA-05-61640	SED	-	7/12/2005	f1	x	-	x	-	x	x	x	x	x	x	x	x	x	x	x	x	x	x	x	x
TH-1C	TH-26428	0	10	CATH-06-70642	SED	-	6/9/2006	c2	-	-	-	-	x	x	x	-	-	x	x	x	-	-	-	-	-	x	x	x
TH-1C	TH-26429	13	37	CATH-06-70643	SED	-	6/9/2006	c2	-	-	-	-	x	x	x	-	-	x	x	x	-	-	-	-	-	x	x	x
TH-1C	TH-26429	37	70	CATH-06-70644	SED	-	6/9/2006	c2	-	-	-	-	x	x	x	-	-	x	x	x	-	-	-	-	-	x	x	x
TH-1C	TH-26431	0	10	CATH-06-70645	SED	-	6/9/2006	c2	-	-	-	-	x	x	x	-	-	x	x	x	-	-	-	-	-	x	x	x
TH-1C	TH-26431	25	41	CATH-06-70646	SED	-	6/9/2006	c2	-	-	-	-	x	x	x	-	-	x	x	x	-	-	-	-	-	x	x	x
TH-1C	TH-26433	3	23	CATH-06-70647	SED	-	6/9/2006	c2	-	-	-	-	x	x	x	-	-	x	x	x	-	-	-	-	-	x	x	x
TH-1C	TH-26433	25	48	CATH-06-70648	SED	-	6/9/2006	c2	-	-	-	-	x	x	x	-	-	x	x	x	-	-	-	-	-	x	x	x
TH-1C	TH-26435	26	56	CATH-06-70649	SED	-	6/9/2006	c2	-	-	-	-	x	x	x	-	-	x	x	x	-	-	-	-	-	x	x	x
TH-1C	TH-26435	26	56	CATH-06-70652	SED	Field Duplicate	6/9/2006	c2	-	-	-	-	x	x	x	-	-	x	x	x	-	-	-	-	-	x	x	-
TH-1C	TH-26436	8	29	CATH-06-70650	SED	-	6/9/2006	c2	-	-	-	-	x	x	x	-	-	x	x	x	-	-	-	-	-	x	x	x
TH-1C	TH-26437	0	14	CATH-06-70651	SED	-	6/9/2006	c1	-	-	-	-	x	x	x	-	-	x	x	x	-	-	-	-	-	x	x	x
TH-1E	TH-25007	0	13	CATH-05-62760	SED	-	7/28/2005	c2	x	-	x	-	x	x	x	x	x	x	x	x	x	x	x	x	x	x	x	x
TH-1E	TH-25007	13	37	CATH-05-62761	SED	-	7/28/2005	c2	x	-	x	-	x	x	x	x	x	x	x	x	x	x	x	x	x	x	x	x
TH-1E	TH-25009	48	80	CATH-05-62762	SED	-	7/28/2005	c2	x	-	x	-	x	x	x	x	x	x	x	x	x	x	x	x	x	x	x	x
TH-1E	TH-25010	0	27	CATH-05-62763	SED	-	7/28/2005	c2	x	-	x	-	x	x	x	x	x	x	x	x	x	x	x	x	x	x	x	x
TH-1E	TH-25010	27	46	CATH-05-62764	SED	-	7/28/2005	c2	x	-	x	-	x	x	x	x	x	x	x	x	x	x	x	x	x	x	x	x
TH-1E	TH-25012	0	11	CATH-05-62765	SED	-	7/28/2005	c1	x	-	x	-	x	x	x	x	x	x	x	x	x	x	x	x	x	x	x	x

Table C-2.0-1 (continued)

Reach	Location ID	Top Depth (cm)	Bottom Depth (cm)	Sample ID	Media Code	Field Code	Collection Date	Geomorphic Unit	Am-241	Anion	CN	Dioxin/Furan	Gamma Spec	H3	HEXP	Iso Pu	Iso Th	Iso U	Metals	PAH	PCB	Perchlorate	PEST	pH	Sr-90	SVOC	VOC	Wet Chem
TH-1E	TH-25013	6	30	CATH-05-62766	SED	-	7/28/2005	f1	x	-	x	-	x	x	x	x	x	x	x	x	x	x	x	x	x	x	x	x
TH-1E	TH-25014	7	37	CATH-05-62767	SED	-	7/28/2005	c2	x	-	x	-	x	x	x	x	x	x	x	x	x	x	x	x	x	x	x	x
TH-1E	TH-25015	15	38	CATH-05-62768	SED	-	7/28/2005	c2	x	-	x	-	x	x	x	x	x	x	x	x	x	x	x	x	x	x	x	x
TH-1E	TH-25016	10	53	CATH-05-62769	SED	-	7/28/2005	c2	x	-	x	-	x	x	x	x	x	x	x	x	x	x	x	x	x	x	x	x
TH-1E	TH-25016	10	53	CATH-05-62790	SED	Field Duplicate	7/28/2005	c2	x	-	x	-	x	x	x	x	x	x	x	x	x	x	x	-	x	x	x	-
TH-3	TH-10001	0	32	CATH-00-0032	SED	-	6/26/2000	c3	x	-	x	-	x	-	x	x	-	x	x	-	x	-	x	-	-	x	-	-
TH-3	TH-10001	0	32	CATH-00-0038	SED	Field Duplicate	6/26/2000	c3	x	-	x	-	x	-	x	x	-	x	x	-	x	-	x	-	-	x	-	-
TH-3	TH-10002	26	61	CATH-00-0033	SED	-	6/26/2000	c3	x	-	x	-	x	-	x	x	-	x	x	-	x	-	x	-	-	x	-	-
TH-3	TH-10003	0	14	CATH-00-0034	SED	-	6/26/2000	c3	x	-	x	-	x	-	x	x	-	x	x	-	x	-	x	-	-	x	-	-
TH-3	TH-10003	19	34	CATH-00-0035	SED	-	6/26/2000	c3	x	-	x	-	x	-	x	x	-	x	x	-	x	-	x	-	-	x	-	-
TH-3	TH-10004	0	21	CATH-00-0036	SED	-	6/26/2000	c2a	x	-	x	-	x	-	x	x	-	x	x	-	x	-	x	-	-	x	-	-
TH-3	TH-10005	0	10	CATH-00-0037	SED	-	6/26/2000	c2	x	-	x	-	x	-	x	x	-	x	x	-	x	-	x	-	-	x	-	-
THM-1	TH-25017	15	31	CATH-05-62770	SED	-	8/10/2005	c2	x	-	x	-	x	x	x	x	x	x	x	x	x	x	x	x	x	x	x	x
THM-1	TH-25017	37	57	CATH-05-62771	SED	-	8/10/2005	c2	x	-	x	-	x	x	x	x	x	x	x	x	x	x	x	x	x	x	x	x
THM-1	TH-25019	7	35	CATH-05-62772	SED	-	8/10/2005	f1	x	-	x	-	x	x	x	x	x	x	x	x	x	x	x	x	x	x	x	x
THM-1	TH-25019	7	35	CATH-05-62791	SED	Field Duplicate	8/10/2005	f1	x	-	x	-	x	x	x	x	x	x	x	x	x	x	x	-	x	x	x	-
THM-1	TH-25020	6	32	CATH-05-62773	SED	-	8/10/2005	f1	x	-	x	-	x	x	x	x	x	x	x	x	x	x	x	x	x	x	x	x
THM-1	TH-25021	31	58	CATH-05-62774	SED	-	8/10/2005	c2? [c3?]	x	-	x	-	x	x	x	x	x	x	x	x	x	x	x	x	x	x	x	x
THM-1	TH-25022	0	24	CATH-05-62775	SED	-	8/10/2005	c1	x	-	x	-	x	x	x	x	x	x	x	x	x	x	x	x	x	x	x	x
THM-1	TH-25023	15	41	CATH-05-62776	SED	-	8/10/2005	c2? [c3?]	x	-	x	-	x	x	x	x	x	x	x	x	x	x	x	x	x	x	x	x
THM-1	TH-25024	0	20	CATH-05-62777	SED	-	8/10/2005	c2	x	-	x	-	x	x	x	x	x	x	x	x	x	x	x	x	x	x	x	x
THM-1	TH-25024	0	30	CATH-08-8465	SED	-	11/6/2007	c2	-	x	x	-	-	-	-	-	-	-	x	x	x	x	x	-	-	x	-	-
THM-1	TH-25025	29	65	CATH-05-62778	SED	-	8/10/2005	c2? [c3?]	x	-	x	-	x	x	x	x	x	x	x	x	x	x	x	x	x	x	x	x
THM-1	TH-25026	0	21	CATH-05-62779	SED	-	8/10/2005	c2	x	-	x	-	x	x	x	x	x	x	x	x	x	x	x	x	x	x	x	x
THS-1E	TH-25027	7	48	CATH-05-62780	SED	-	8/22/2005	c2	x	-	x	-	x	x	x	x	x	x	x	x	x	x	x	x	x	x	x	x
THS-1E	TH-25028	0	36	CATH-05-62781	SED	-	8/22/2005	c1b	x	-	x	-	x	x	x	x	x	x	x	x	x	x	x	x	x	x	x	x

Table C-2.0-1 (continued)

Reach	Location ID	Top Depth (cm)	Bottom Depth (cm)	Sample ID	Media Code	Field Code	Collection Date	Geomorphic Unit	Am-241	Anion	CN	Dioxin/Furan	Gamma Spec	H3	HEXP	Iso Pu	Iso Th	Iso U	Metals	PAH	PCB	Perchlorate	PEST	pH	Sr-90	SVOC	VOC	Wet Chem
THS-1E	TH-25028	48	67	CATH-05-62782	SED	-	8/22/2005	c1b	x	-	x	-	x	x	x	x	x	x	x	x	x	x	x	x	x	x	x	x
THS-1E	TH-25030	0	52	CATH-05-62783	SED	-	8/22/2005	c1	x	-	x	-	x	x	x	x	x	x	x	x	x	x	x	x	x	x	x	x
THS-1E	TH-25031	5	25	CATH-05-62784	SED	-	8/22/2005	c2	x	-	x	-	x	x	x	x	x	x	x	x	x	x	x	x	x	x	x	x
THS-1E	TH-25031	34	51	CATH-05-62785	SED	-	8/22/2005	c2	x	-	x	-	x	x	x	x	x	x	x	x	x	x	x	x	x	x	x	x
THS-1E	TH-25031	51	81	CATH-05-62786	SED	-	8/22/2005	c2	x	-	x	-	x	x	x	x	x	x	x	x	x	x	x	x	x	x	x	x
THS-1E	TH-25034	0	25	CATH-05-62787	SED	-	8/22/2005	c2	x	-	x	-	x	x	x	x	x	x	x	x	x	x	x	x	x	x	x	x
THS-1E	TH-25034	0	25	CATH-05-62792	SED	Field Duplicate	8/22/2005	c2	x	-	x	-	x	x	x	x	x	x	x	x	x	x	x	-	x	x	x	-
THS-1E	TH-25034	25	68	CATH-05-62788	SED	-	8/22/2005	c2	x	-	x	-	x	x	x	x	x	x	x	x	x	x	x	x	x	x	x	x
THS-1E	TH-25036	2	38	CATH-05-62789	SED	-	8/22/2005	f1	x	-	x	-	x	x	x	x	x	x	x	x	x	x	x	x	x	x	x	x
THS-1W	TH-26438	0	32	CATH-06-70655	SED	-	6/13/2006	c1	-	-	-	-	-	x	x	-	x	x	x	x	-	x	-	-	-	x	x	x
THS-1W	TH-26439	4	27	CATH-06-70656	SED	-	6/13/2006	c2	-	-	-	-	-	x	x	-	x	x	x	x	-	x	-	-	-	x	x	x
THS-1W	TH-26439	27	44	CATH-06-70657	SED	-	6/13/2006	c2	-	-	-	-	-	x	x	-	x	x	x	x	-	x	-	-	-	x	x	x
THS-1W	TH-26441	0	15	CATH-06-70658	SED	-	6/13/2006	c2	-	-	-	-	-	x	x	-	x	x	x	x	-	x	-	-	-	x	x	x
THS-1W	TH-26442	0	15	CATH-06-70659	SED	-	6/13/2006	f1	-	-	-	-	-	x	x	-	x	x	x	x	-	x	-	-	-	x	x	x
THS-1W	TH-26443	0	23	CATH-06-70660	SED	-	6/13/2006	c2	-	-	-	-	-	x	x	-	x	x	x	x	-	x	-	-	-	x	x	x
THS-1W	TH-26443	0	23	CATH-06-70665	SED	Field Duplicate	6/13/2006	c2	-	-	-	-	-	x	x	-	x	x	x	x	-	x	-	-	-	x	x	-
THS-1W	TH-26444	0	10	CATH-06-70661	SED	-	6/13/2006	c1	-	-	-	-	-	x	x	-	x	x	x	x	-	x	-	-	-	x	x	x
THS-1W	TH-26445	9	33	CATH-06-70662	SED	-	6/13/2006	f1	-	-	-	-	-	x	x	-	x	x	x	x	-	x	-	-	-	x	x	x
THS-1W	TH-26446	11	49	CATH-06-70663	SED	-	6/13/2006	c2	-	-	-	-	-	x	x	-	x	x	x	x	-	x	-	-	-	x	x	x
THS-1W	TH-26447	5	47	CATH-06-70664	SED	-	6/13/2006	f1	-	-	-	-	-	x	x	-	x	x	x	x	-	x	-	-	-	x	x	x
THW-1	TH-26448	9	25	CATH-06-70668	SED	-	6/9/2006	c2	-	-	-	-	x	x	x	-	-	x	x	x	-	-	-	-	-	x	x	x
THW-1	TH-26448	46	60	CATH-06-70669	SED	-	6/9/2006	c2	-	-	-	-	x	x	x	-	-	x	x	x	-	-	-	-	-	x	x	x
THW-1	TH-26450	13	21	CATH-06-70670	SED	-	6/9/2006	c2	-	-	-	-	x	x	x	-	-	x	x	x	-	-	-	-	-	x	x	x
THW-1	TH-26451	0	8	CATH-06-70671	SED	-	6/9/2006	f1	-	-	-	-	x	x	x	-	-	x	x	x	-	-	-	-	-	x	x	x
THW-1	TH-26452	0	18	CATH-06-70672	SED	-	6/9/2006	c1	-	-	-	-	x	x	x	-	-	x	x	x	-	-	-	-	-	x	x	x
THW-1	TH-26452	18	43	CATH-06-70673	SED	-	6/9/2006	c1	-	-	-	-	x	x	x	-	-	x	x	x	-	-	-	-	-	x	x	x
THW-1	TH-26454	15	35	CATH-06-70674	SED	-	6/12/2006	c2	-	-	-	-	x	x	x	-	-	x	x	x	-	-	-	-	-	x	x	x

Table C-2.0-1 (continued)

Reach	Location ID	Top Depth (cm)	Bottom Depth (cm)	Sample ID	Media Code	Field Code	Collection Date	Geomorphic Unit	Am-241	Anion	CN	Dioxin/Furan	Gamma Spec	H3	HEXP	Iso Pu	Iso Th	Iso U	Metals	PAH	PCB	Perchlorate	PEST	pH	Sr-90	SVOC	VOC	Wet Chem
THW-1	TH-26455	4	45	CATH-06-70675	SED	-	6/9/2006	f1	-	-	-	-	x	x	x	-	-	x	x	x	-	-	-	-	-	x	x	x
THW-1	TH-26456	0	13	CATH-06-70676	SED	-	6/9/2006	f1	-	-	-	-	x	x	x	-	-	x	x	x	-	-	-	-	-	x	x	x
THW-1	TH-26456	0	13	CATH-06-70678	SED	Field Duplicate	6/9/2006	f1	-	-	-	-	x	x	x	-	-	x	x	x	-	-	-	-	-	x	x	-
THW-1	TH-26456	13	26	CATH-06-70677	SED	-	6/9/2006	f1	-	-	-	-	x	x	x	-	-	x	x	x	-	-	-	-	-	x	x	x
TW-1E	TW-24825	16	31	CATW-05-61605	SED	-	7/12/2005	f1	x	-	x	-	x	x	x	x	x	x	x	x	x	x	x	x	x	x	x	x
TW-1E	TW-24825	16	31	CATW-06-70681	SED	-	6/22/2006	f1	-	-	-	x	-	-	-	-	-	-	-	-	-	-	-	-	-	-	-	-
TW-1E	TW-24826	0	27	CATW-05-61606	SED	-	7/12/2005	c1	x	-	x	-	x	x	x	x	x	x	x	x	x	x	x	x	x	x	x	x
TW-1E	TW-24826	0	27	CATW-06-70682	SED	-	6/22/2006	c1	-	-	-	x	-	-	-	-	-	-	-	-	-	-	-	-	-	-	-	-
TW-1E	TW-24827	0	28	CATW-05-61607	SED	-	7/12/2005	c2	x	-	x	-	x	x	x	x	x	x	x	x	x	x	x	x	x	x	x	x
TW-1E	TW-24827	0	28	CATW-06-70683	SED	-	6/22/2006	c2	-	-	-	x	-	-	-	-	-	-	-	-	-	-	-	-	-	-	-	-
TW-1E	TW-24827	28	48	CATW-05-61608	SED	-	7/12/2005	c2	x	-	x	-	x	x	x	x	x	x	x	x	x	x	x	x	x	x	x	x
TW-1E	TW-24827	28	48	CATW-06-70684	SED	-	6/22/2006	c2	-	-	-	x	-	-	-	-	-	-	-	-	-	-	-	-	-	-	-	-
TW-1E	TW-24829	39	56	CATW-05-61609	SED	-	7/12/2005	c2	x	-	x	-	x	x	x	x	x	x	x	x	x	x	x	x	x	x	x	x
TW-1E	TW-24829	39	56	CATW-06-70685	SED	-	6/22/2006	c2	-	-	-	x	-	-	-	-	-	-	-	-	-	-	-	-	-	-	-	-
TW-1E	TW-24830	0	23	CATW-05-61610	SED	-	7/12/2005	f1	x	-	x	-	x	x	x	x	x	x	x	x	x	x	x	x	x	x	x	x
TW-1E	TW-24830	0	23	CATW-05-61625	SED	Field Duplicate	7/12/2005	f1	x	-	x	-	x	x	x	x	x	x	x	x	x	x	x	-	x	x	x	-
TW-1E	TW-24830	0	30	CATW-08-8458	SED	-	11/7/2007	f1	-	x	x	-	-	-	-	-	-	-	x	x	x	x	x	-	-	x	-	-
TW-1E	TW-24830	0	23	CATW-06-70686	SED	-	6/22/2006	f1	-	-	-	x	-	-	-	-	-	-	-	-	-	-	-	-	-	-	-	-
TW-1E	TW-24830	0	23	CATW-06-70691	SED	Field Duplicate	6/22/2006	f1	-	-	-	x	-	-	-	-	-	-	-	-	-	-	-	-	-	-	-	-
TW-1E	TW-24831	0	20	CATW-05-61611	SED	-	7/12/2005	c1b	x	-	x	-	x	x	x	x	x	x	x	x	x	x	x	x	x	x	x	x
TW-1E	TW-24831	0	20	CATW-06-70687	SED	-	6/22/2006	c1b	-	-	-	x	-	-	-	-	-	-	-	-	-	-	-	-	-	-	-	-
TW-1E	TW-24832	21	49	CATW-05-61612	SED	-	7/12/2005	c2	x	-	x	-	x	x	x	x	x	x	x	x	x	x	x	x	x	x	x	x
TW-1E	TW-24832	21	49	CATW-06-70688	SED	-	6/22/2006	c2	-	-	-	x	-	-	-	-	-	-	-	-	-	-	-	-	-	-	-	-
TW-1E	TW-24833	0	33	CATW-05-61613	SED	-	7/12/2005	c1	x	-	x	-	x	x	x	x	x	x	x	x	x	x	x	x	x	x	x	x
TW-1E	TW-24833	0	33	CATW-06-70689	SED	-	6/22/2006	c1	-	-	-	x	-	-	-	-	-	-	-	-	-	-	-	-	-	-	-	-
TW-1E	TW-24834	3	63	CATW-05-61614	SED	-	7/12/2005	c2	x	-	x	-	x	x	x	x	x	x	x	x	x	x	x	x	x	x	x	x

Table C-2.0-1 (continued)

Reach	Location ID	Top Depth (cm)	Bottom Depth (cm)	Sample ID	Media Code	Field Code	Collection Date	Geomorphic Unit	Am-241	Anion	CN	Dioxin/Furan	Gamma Spec	H3	HEXP	Iso Pu	Iso Th	Iso U	Metals	PAH	PCB	Perchlorate	PEST	pH	Sr-90	SVOC	VOC	Wet Chem
TW-1E	TW-24834	3	63	CATW-06-70690	SED	-	6/22/2006	c2	-	-	-	x	-	-	-	-	-	-	-	-	-	-	-	-	-	-	-	-
TW-1W	TW-26458	0	27	CATW-06-70692	SED	-	6/21/2006	c1	-	-	-	x	-	-	-	-	-	-	x	x	x	x	x	-	-	x	x	x
TW-1W	TW-26459	23	105	CATW-06-70693	SED	-	6/21/2006	c3	-	-	-	x	-	-	-	-	-	-	x	x	x	x	x	-	-	x	x	x
TW-1W	TW-26460	0	30	CATW-08-8459	SED	-	11/7/2007	f1	-	x	x	-	-	-	-	-	-	-	x	x	x	x	x	-	-	x	-	-
TW-1W	TW-26460	2	13	CATW-06-70694	SED	-	6/21/2006	f1	-	-	-	x	-	-	-	-	-	-	x	x	x	x	x	-	-	x	x	x
TW-1W	TW-26461	18	68	CATW-06-70695	SED	-	6/21/2006	c2	-	-	-	x	-	-	-	-	-	-	x	x	x	x	x	-	-	x	x	x
TW-1W	TW-26461	18	68	CATW-06-70702	SED	Field Duplicate	6/21/2006	c2	-	-	-	x	-	-	-	-	-	-	x	x	x	x	x	-	-	x	x	-
TW-1W	TW-26462	0	12	CATW-06-70696	SED	-	6/21/2006	f1	-	-	-	x	-	-	-	-	-	-	x	x	x	x	x	-	-	x	x	x
TW-1W	TW-26462	12	22	CATW-06-70697	SED	-	6/21/2006	f1	-	-	-	x	-	-	-	-	-	-	x	x	x	x	x	-	-	x	x	x
TW-1W	TW-26464	0	35	CATW-06-70698	SED	-	6/21/2006	c1	-	-	-	x	-	-	-	-	-	-	x	x	x	x	x	-	-	x	x	x
TW-1W	TW-26465	0	26	CATW-06-70699	SED	-	6/21/2006	c2	-	-	-	x	-	-	-	-	-	-	x	x	x	x	x	-	-	x	x	x
TW-1W	TW-26465	26	33	CATW-06-70700	SED	-	6/21/2006	c2	-	-	-	x	-	-	-	-	-	-	x	x	x	x	x	-	-	x	x	x
TW-1W	TW-26467	0	23	CATW-06-70701	SED	-	6/21/2006	f1	-	-	-	x	-	-	-	-	-	-	x	x	x	x	x	-	-	x	x	x
TW-2E	TW-10016	0	13	CATW-00-0021	SED	-	6/28/2000	c2	x	-	x	-	x	-	x	x	-	x	x	-	x	-	x	-	-	x	-	-
TW-2E	TW-10017	7	24	CATW-00-0022	SED	-	6/28/2000	c3? [f1?]	x	-	x	-	x	-	x	x	-	x	x	-	x	-	x	-	-	x	-	-
TW-2E	TW-10017	23	41	CATW-00-0023	SED	-	6/28/2000	c3? [f1?]	x	-	x	-	x	-	x	x	-	x	x	-	x	-	x	-	-	x	-	-
TW-2E	TW-10018	0	9	CATW-00-0024	SED	-	6/28/2000	c3	x	-	x	-	x	-	x	x	-	x	x	-	x	-	x	-	-	x	-	-
TW-2E	TW-10019	0	13	CATW-00-0025	SED	-	6/29/2000	c2	x	-	x	-	x	-	x	x	-	x	x	-	x	-	x	-	-	x	-	-
TW-2E	TW-10019	13	29	CATW-00-0026	SED	-	6/29/2000	c2	x	-	x	-	x	-	x	x	-	x	x	-	x	-	x	-	-	x	-	-
TW-2E	TW-10019	13	29	CATW-00-0028	SED	Field Duplicate	6/29/2000	c2	x	-	x	-	x	-	x	x	-	x	x	-	x	-	x	-	-	x	-	-
TW-2E	TW-10020	0	13	CATW-00-0027	SED	-	6/29/2000	c2	x	-	x	-	x	-	x	x	-	x	x	-	x	-	x	-	-	x	-	-
TW-2E	TW-601031	4	33	CATW-07-4759	SED	-	8/2/2007	f1	-	-	-	x	-	-	-	-	-	-	x	x	x	-	-	-	-	-	-	-
TW-2E	TW-601031	4	33	CATW-07-4769	SED	Field Duplicate	8/2/2007	f1	-	-	-	x	-	-	-	-	-	-	x	x	x	-	-	-	-	-	-	-
TW-2E	TW-601032	0	17	CATW-07-4760	SED	-	8/2/2007	c2	-	-	-	x	-	-	-	-	-	-	x	x	x	-	-	-	-	-	-	-
TW-2E	TW-601033	23	52	CATW-07-4761	SED	-	8/2/2007	c3	-	-	-	x	-	-	-	-	-	-	x	x	x	-	-	-	-	-	-	-
TW-2E	TW-601033	74	90	CATW-07-4762	SED	-	8/2/2007	c3	-	-	-	x	-	-	-	-	-	-	x	x	x	-	-	-	-	-	-	-

Table C-2.0-1 (continued)

Reach	Location ID	Top Depth (cm)	Bottom Depth (cm)	Sample ID	Media Code	Field Code	Collection Date	Geomorphic Unit	Am-241	Anion	CN	Dioxin/Furan	Gamma Spec	H3	HEXP	Iso Pu	Iso Th	Iso U	Metals	PAH	PCB	Perchlorate	PEST	pH	Sr-90	SVOC	VOC	Wet Chem
TW-2E	TW-601035	0	5	CATW-07-4763	SED	-	8/2/2007	c1	-	-	-	x	-	-	-	-	-	-	x	x	x	-	-	-	-	-	-	-
TW-2E	TW-601036	0	5	CATW-07-4764	SED	-	8/2/2007	c1	-	-	-	x	-	-	-	-	-	-	x	x	x	-	-	-	-	-	-	-
TW-2E	TW-601037	0	34	CATW-07-4765	SED	-	8/2/2007	f1	-	-	-	x	-	-	-	-	-	-	x	x	x	-	-	-	-	-	-	-
TW-2E	TW-601038	14	41	CATW-07-4766	SED	-	8/2/2007	c2	-	-	-	x	-	-	-	-	-	-	x	x	x	-	-	-	-	-	-	-
TW-2E	TW-601038	48	64	CATW-07-4767	SED	-	8/2/2007	c2	-	-	-	x	-	-	-	-	-	-	x	x	x	-	-	-	-	-	-	-
TW-2E	TW-601040	3	11	CATW-07-4768	SED	-	8/2/2007	f1	-	-	-	x	-	-	-	-	-	-	x	x	x	-	-	-	-	-	-	-
TW-2E	TW-603109	0	15	CATW-08-8462	SED	-	11/7/2007	c1	-	-	-	-	-	-	-	-	-	-	x	x	x	-	x	-	-	x	-	-
TW-3E	TW-26551	7	39	CATW-06-71114	SED	-	6/21/2006	f1	x	-	x	-	x	x	x	x	-	x	x	x	x	x	x	-	-	x	x	x
TW-3E	TW-26551	7	39	CATW-06-71124	SED	Field Duplicate	6/21/2006	f1	x	-	x	-	x	x	x	x	-	x	x	x	x	x	x	-	-	x	x	-
TW-3E	TW-26552	0	52	CATW-06-71115	SED	-	6/21/2006	c1	x	-	x	-	x	x	x	x	-	x	x	x	x	x	x	-	-	x	x	x
TW-3E	TW-26553	14	42	CATW-06-71116	SED	-	6/21/2006	f1	x	-	x	-	x	x	x	x	-	x	x	x	x	x	x	-	-	x	x	x
TW-3E	TW-26554	6	31	CATW-06-71117	SED	-	6/21/2006	f1	x	-	x	-	x	x	x	x	-	x	x	x	x	x	x	-	-	x	x	x
TW-3E	TW-26555	0	50	CATW-06-71118	SED	-	6/21/2006	c1	x	-	x	-	x	x	x	x	-	x	x	x	x	x	x	-	-	x	x	x
TW-3E	TW-26556	12	40	CATW-06-71119	SED	-	6/21/2006	c2	x	-	x	-	x	x	x	x	-	x	x	x	x	x	x	-	-	x	x	x
TW-3E	TW-26557	0	25	CATW-06-71120	SED	-	6/21/2006	f1	x	-	x	-	x	x	x	x	-	x	x	x	x	x	x	-	-	x	x	x
TW-3E	TW-26558	7	43	CATW-06-71121	SED	-	6/21/2006	f1	x	-	x	-	x	x	x	x	-	x	x	x	x	x	x	-	-	x	x	x
TW-3E	TW-26558	43	69	CATW-06-71122	SED	-	6/21/2006	f1	x	-	x	-	x	x	x	x	-	x	x	x	x	x	x	-	-	x	x	x
TW-3E	TW-26560	0	28	CATW-06-71123	SED	-	6/21/2006	c2	x	-	x	-	x	x	x	x	-	x	x	x	x	x	x	-	-	x	x	x
TW-4E	TW-26509	0	15	CATW-06-71061	SED	-	6/14/2006	c1	x	-	x	-	x	x	x	x	-	x	x	x	x	x	x	-	-	x	x	x
TW-4E	TW-26510	0	5	CATW-06-71062	SED	-	6/14/2006	f2	x	-	x	-	x	x	x	x	-	x	x	x	x	x	x	-	-	x	x	x
TW-4E	TW-601029	0	13	CATW-07-4757	SED	-	8/1/2007	c2	x	-	-	x	x	x	x	x	-	-	x	x	x	x	x	-	x	x	x	x
TW-4E	TW-601030	0	8	CATW-07-4758	SED	-	8/1/2007	f1? [c2?]	x	-	-	x	x	x	x	x	-	-	x	x	x	x	x	-	x	x	x	x
TW-4W	TW-10005	0	18	CATW-00-0009	SED	-	6/23/2000	c2	x	-	x	-	x	-	x	x	-	x	x	-	x	-	x	-	-	x	-	-
TW-4W	TW-10006	0	31	CATW-00-0010	SED	-	6/23/2000	c2	x	-	x	-	x	-	x	x	-	x	x	-	x	-	x	-	-	x	-	-
TW-4W	TW-10007	0	13	CATW-00-0011	SED	-	6/23/2000	c2	x	-	x	-	x	-	x	x	-	x	x	-	x	-	x	-	-	x	-	-
TW-4W	TW-10008	0	17	CATW-00-0012	SED	-	6/23/2000	f1	x	-	x	-	x	-	x	x	-	x	x	-	x	-	x	-	-	x	-	-
TW-4W	TW-10008	0	17	CATW-05-62406	SED	-	7/22/2005	f1	-	-	-	-	-	x	x	-	x	-	-	x	-	x	-	x	x	-	x	x

Table C-2.0-1 (continued)

Reach	Location ID	Top Depth (cm)	Bottom Depth (cm)	Sample ID	Media Code	Field Code	Collection Date	Geomorphic Unit	Am-241	Anion	CN	Dioxin/Furan	Gamma Spec	H3	HEXP	Iso Pu	Iso Th	Iso U	Metals	PAH	PCB	Perchlorate	PEST	pH	Sr-90	SVOC	VOC	Wet Chem
TW-4W	TW-10009	0	26	CATW-00-0013	SED	-	6/23/2000	c2	x	-	x	-	x	-	x	x	-	x	x	-	x	-	x	-	-	x	-	-
TW-4W	TW-10010	0	21	CATW-00-0014	SED	-	6/23/2000	c2	x	-	x	-	x	-	x	x	-	x	x	-	x	-	x	-	-	x	-	-
TW-4W	TW-10010	9	33	CATW-05-62404	SED	-	7/22/2005	c2	-	-	-	-	-	x	x	-	x	-	-	x	-	x	-	x	x	-	x	x
TW-4W	TW-10010	21	34	CATW-00-0015	SED	-	6/23/2000	c2	x	-	x	-	x	-	x	x	-	x	x	-	x	-	x	-	-	x	-	-
TW-4W	TW-10010	33	46	CATW-05-62405	SED	-	7/22/2005	c2	-	-	-	-	-	x	x	-	x	-	-	x	-	x	-	x	x	-	x	x
TW-4W	TW-10011	14	30	CATW-00-0016	SED	-	6/23/2000	f1	x	-	x	-	x	-	x	x	-	x	x	-	x	-	x	-	-	x	-	-
TW-4W	TW-10011	14	30	CATW-05-62403	SED	-	7/22/2005	f1	-	-	-	-	-	x	x	-	x	-	-	x	-	x	-	x	x	-	x	x
TW-4W	TW-24945	17	41	CATW-05-62379	SED	-	7/22/2005	c2	x	-	x	-	x	x	x	x	-	x	x	x	x	x	x	x	x	x	x	x
TW-4W	TW-24946	18	48	CATW-05-62380	SED	-	7/22/2005	c3	x	-	x	-	x	x	x	x	-	x	x	x	x	x	x	x	x	x	x	x
TW-4W	TW-24946	59	80	CATW-05-62381	SED	-	7/22/2005	c3	x	-	x	-	x	x	x	x	-	x	x	x	x	x	x	x	x	x	x	x
TW-4W	TW-24948	0	27	CATW-05-62382	SED	-	7/22/2005	f1	x	-	x	-	x	x	x	x	-	x	x	x	x	x	x	x	x	x	x	x
TW-4W	TW-24948	0	27	CATW-05-62409	SED	Field Duplicate	7/22/2005	f1	x	-	x	-	x	x	x	x	-	x	x	x	x	x	x	-	x	x	x	-
TW-4W	TW-24949	0	26	CATW-05-62383	SED	-	7/22/2005	c2	x	-	x	-	x	x	x	x	-	x	x	x	x	x	x	x	x	x	x	x
TW-4W	TW-24950	0	10	CATW-05-62384	SED	-	7/22/2005	c1	x	-	x	-	x	x	x	x	-	x	x	x	x	x	x	x	x	x	x	x
TWN-1E	TW-24835	0	33	CATW-05-61615	SED	-	7/12/2005	f1	x	-	x	-	x	x	x	x	x	x	x	x	-	x	x	x	x	x	x	x
TWN-1E	TW-24835	0	33	CATW-05-61626	SED	Field Duplicate	7/12/2005	f1	x	-	x	-	x	x	x	x	x	x	x	x	x	x	x	-	x	x	x	-
TWN-1E	TW-24836	0	30	CATW-08-8460	SED	-	11/7/2007	c1	-	x	x	-	-	-	-	-	-	-	x	x	x	x	x	-	-	x	-	-
TWN-1E	TW-24836	0	30	CATW-08-8463	SED	Field Duplicate	11/7/2007	c1	-	-	x	-	-	-	-	-	-	-	x	x	x	x	x	-	-	x	-	x
TWN-1E	TW-24836	8	56	CATW-05-61616	SED	-	7/12/2005	c1	x	-	x	-	x	x	x	x	x	x	x	x	x	x	x	x	x	x	x	x
TWN-1E	TW-24837	0	38	CATW-05-61617	SED	-	7/12/2005	c1	x	-	x	-	x	x	x	x	x	x	x	x	x	x	x	x	x	x	x	x
TWN-1E	TW-24837	0	38	CATW-06-70705	SED	-	6/21/2006	c1	-	-	-	-	-	-	-	-	-	-	-	x	-	-	-	-	-	-	-	-
TWN-1E	TW-24837	38	63	CATW-05-61618	SED	-	7/12/2005	c1	x	-	x	-	x	x	x	x	x	x	x	x	x	x	x	x	x	x	x	x
TWN-1E	TW-24839	0	22	CATW-05-61619	SED	-	7/12/2005	f1	x	-	x	-	x	x	x	x	x	x	x	x	x	x	x	x	x	x	x	x
TWN-1E	TW-24840	0	23	CATW-05-61620	SED	-	7/12/2005	f1	x	-	x	-	x	x	x	x	x	x	x	x	x	x	x	x	x	x	x	x
TWN-1E	TW-24841	0	37	CATW-05-61621	SED	-	7/12/2005	c1	x	-	x	-	x	x	x	x	x	x	x	x	x	x	x	x	x	x	x	x
TWN-1E	TW-24842	0	28	CATW-05-61622	SED	-	7/12/2005	c3	x	-	x	-	x	x	x	x	x	x	x	x	x	x	x	x	x	x	x	x

Table C-2.0-1 (continued)

Reach	Location ID	Top Depth (cm)	Bottom Depth (cm)	Sample ID	Media Code	Field Code	Collection Date	Geomorphic Unit	Am-241	Anion	CN	Dioxin/Furan	Gamma Spec	H3	HEXP	Iso Pu	Iso Th	Iso U	Metals	PAH	PCB	Perchlorate	PEST	pH	Sr-90	SVOC	VOC	Wet Chem
TWN-1E	TW-24842	28	98	CATW-05-61623	SED	-	7/12/2005	c3	x	-	x	-	x	x	x	x	x	x	x	x	x	x	x	x	x	x	x	x
TWN-1E	TW-24844	0	22	CATW-05-61624	SED	-	7/12/2005	c2	x	-	x	-	x	x	x	x	x	x	x	x	x	x	x	x	x	x	x	x
TWN-1E	TW-26468	0	20	CATW-06-70706	SED	-	6/21/2006	c1	-	-	x	-	x	-	-	x	-	-	x	x	x	x	-	-	-	x	x	x
TWN-1E	TW-26469	0	10	CATW-06-70707	SED	-	6/21/2006	c1	-	-	x	-	x	-	-	x	-	-	x	x	x	x	-	-	-	x	x	x
TWN-1W	TW-26470	0	22	CATW-06-70708	SED	-	6/22/2006	c2	-	-	x	-	x	-	-	x	-	-	x	x	x	x	-	-	-	x	x	x
TWN-1W	TW-26470	0	22	CATW-06-70718	SED	Field Duplicate	6/22/2006	c2	-	-	x	-	x	-	-	x	-	-	x	x	x	x	-	-	-	x	x	-
TWN-1W	TW-26470	22	39	CATW-06-70709	SED	-	6/22/2006	c2	-	-	x	-	x	-	-	x	-	-	x	x	x	x	-	-	-	x	x	x
TWN-1W	TW-26472	3	33	CATW-06-70710	SED	-	6/22/2006	f1	-	-	x	-	x	-	-	x	-	-	x	x	x	x	-	-	-	x	x	x
TWN-1W	TW-26473	11	24	CATW-06-70711	SED	-	6/22/2006	c1	-	-	x	-	x	-	-	x	-	-	x	x	x	x	-	-	-	x	x	x
TWN-1W	TW-26474	29	59	CATW-06-70712	SED	-	6/22/2006	c2	-	-	x	-	x	-	-	x	-	-	x	x	x	x	-	-	-	x	x	x
TWN-1W	TW-26475	0	26	CATW-06-70713	SED	-	6/22/2006	c1	-	-	x	-	x	-	-	x	-	-	x	x	x	x	-	-	-	x	x	x
TWN-1W	TW-26476	3	33	CATW-06-70714	SED	-	6/22/2006	c2	-	-	x	-	x	-	-	x	-	-	x	x	x	x	-	-	-	x	x	x
TWN-1W	TW-26477	0	10	CATW-06-70715	SED	-	6/22/2006	c1	-	-	x	-	x	-	-	x	-	-	x	x	x	x	-	-	-	x	x	x
TWN-1W	TW-26478	26	57	CATW-06-70716	SED	-	6/22/2006	c2	-	-	x	-	x	-	-	x	-	-	x	x	x	x	-	-	-	x	x	x
TWN-1W	TW-26478	68	79	CATW-06-70717	SED	-	6/22/2006	c2	-	-	x	-	x	-	-	x	-	-	x	x	x	x	-	-	-	x	x	x
TWSE-1E	TW-10012	0	23	CATW-00-0017	SED	-	6/23/2000	c2	x	-	x	-	x	-	x	x	-	x	x	-	x	-	x	-	-	x	-	-
TWSE-1E	TW-10013	0	46	CATW-00-0018	SED	-	6/23/2000	f1	x	-	x	-	x	-	x	x	-	x	x	-	x	-	x	-	-	x	-	-
TWSE-1E	TW-10013	0	34	CATW-05-62402	SED	-	7/22/2005	f1	-	-	-	-	-	x	x	-	x	-	-	x	-	x	-	x	x	-	x	x
TWSE-1E	TW-10014	0	20	CATW-00-0019	SED	-	6/23/2000	c3	x	-	x	-	x	-	x	x	-	x	x	-	x	-	x	-	-	x	-	-
TWSE-1E	TW-10014	0	20	CATW-05-62401	SED	-	7/22/2005	c3	-	-	-	-	-	x	x	-	x	-	-	x	-	x	-	x	x	-	x	x
TWSE-1E	TW-10015	0	18	CATW-00-0020	SED	-	6/23/2000	c2	x	-	x	-	x	-	x	x	-	x	x	-	x	-	x	-	-	x	-	-
TWSE-1E	TW-10015	9	25	CATW-05-62400	SED	-	7/22/2005	c2	-	-	-	-	-	x	x	-	x	-	-	x	-	x	-	x	x	-	x	x
TWSE-1E	TW-24938	0	30	CATW-05-62372	SED	-	7/22/2005	c1b	x	-	x	-	x	x	x	x	-	x	x	x	x	x	x	x	x	x	x	x
TWSE-1E	TW-24939	0	34	CATW-05-62373	SED	-	7/22/2005	c2	x	-	x	-	x	x	x	x	-	x	x	x	x	x	x	x	x	x	x	x
TWSE-1E	TW-24939	34	60	CATW-05-62374	SED	-	7/22/2005	c2	x	-	x	-	x	x	x	x	-	x	x	x	x	x	x	x	x	x	x	x
TWSE-1E	TW-24941	30	80	CATW-05-62375	SED	-	7/22/2005	c3	x	-	x	-	x	x	x	x	-	x	x	x	x	x	x	x	x	x	x	x
TWSE-1E	TW-24942	5	23	CATW-05-62376	SED	-	7/22/2005	f1	x	-	x	-	x	x	x	x	-	x	x	x	x	x	x	x	x	x	x	x

Table C-2.0-1 (continued)

Reach	Location ID	Top Depth (cm)	Bottom Depth (cm)	Sample ID	Media Code	Field Code	Collection Date	Geomorphic Unit	Am-241	Anion	CN	Dioxin/Furan	Gamma Spec	H3	HEXP	Iso Pu	Iso Th	Iso U	Metals	PAH	PCB	Perchlorate	PEST	pH	Sr-90	SVOC	VOC	Wet Chem
TWSE-1E	TW-24943	0	50	CATW-05-62377	SED	-	7/22/2005	c1	x	-	x	-	x	x	x	x	-	x	x	x	x	x	x	x	x	x	x	x
TWSE-1E	TW-24944	0	25	CATW-05-62378	SED	-	7/22/2005	f1	x	-	x	-	x	x	x	x	-	x	x	x	x	x	x	x	x	x	x	x
TWSE-1E	TW-24944	0	25	CATW-05-62408	SED	Field Duplicate	7/22/2005	f1	x	-	x	-	x	x	x	x	-	x	x	x	x	x	x	-	x	x	x	-
TWSE-1W	TW-26521	0	27	CATW-06-71076	SED	-	5/25/2006	f1	x	-	x	-	x	x	x	x	x	x	x	x	x	x	x	-	x	x	x	x
TWSE-1W	TW-26522	0	37	CATW-06-71077	SED	-	5/25/2006	c2	x	-	x	-	x	x	x	x	x	x	x	x	x	x	x	-	x	x	x	x
TWSE-1W	TW-26523	0	42	CATW-06-71078	SED	-	5/25/2006	c2	x	-	x	-	x	x	x	x	x	x	x	x	x	x	x	-	x	x	x	x
TWSE-1W	TW-26524	0	30	CATW-08-8461	SED	-	11/7/2007	c2	-	x	x	-	-	-	-	-	-	-	x	x	x	x	x	-	-	x	-	-
TWSE-1W	TW-26524	2	37	CATW-06-71079	SED	-	5/25/2006	c2	x	-	x	-	x	x	x	x	x	x	x	x	x	x	x	-	x	x	x	x
TWSE-1W	TW-26524	2	37	CATW-06-71086	SED	Field Duplicate	5/25/2006	c2	x	-	x	-	x	x	x	x	x	x	x	x	x	x	x	-	x	x	x	-
TWSE-1W	TW-26525	0	32	CATW-06-71080	SED	-	5/25/2006	c2	x	-	x	-	x	x	x	x	x	x	x	x	x	x	x	-	x	x	x	x
TWSE-1W	TW-26525	32	52	CATW-06-71081	SED	-	5/25/2006	c2	x	-	x	-	x	x	x	x	x	x	x	x	x	x	x	-	x	x	x	x
TWSE-1W	TW-26527	2	29	CATW-06-71082	SED	-	5/25/2006	f1	x	-	x	-	x	x	x	x	x	x	x	x	x	x	x	-	x	x	x	x
TWSE-1W	TW-26528	1	35	CATW-06-71083	SED	-	5/25/2006	f1	x	-	x	-	x	x	x	x	x	x	x	x	x	x	x	-	x	x	x	x
TWSE-1W	TW-26528	35	61	CATW-06-71084	SED	-	5/25/2006	f1	x	-	x	-	x	x	x	x	x	x	x	x	x	x	x	-	x	x	x	x
TWSE-1W	TW-26530	0	12	CATW-06-71085	SED	-	5/25/2006	c1	x	-	x	-	x	x	x	x	x	x	x	x	x	x	x	-	x	x	x	x
TWSW-1E	TW-10000	0	22	CATW-00-0001	SED	-	6/23/2000	f1	x	-	x	-	x	-	x	x	-	x	x	-	x	-	x	-	-	x	-	-
TWSW-1E	TW-10000	0	22	CATW-05-62399	SED	-	7/19/2005	f1	-	-	-	-	-	x	x	-	x	-	-	x	-	x	-	x	x	-	x	x
TWSW-1E	TW-10001	0	25	CATW-00-0002	SED	-	6/23/2000	c2	x	-	x	-	x	-	x	x	-	x	x	-	x	-	x	-	-	x	-	-
TWSW-1E	TW-10001	12	37	CATW-05-62398	SED	-	7/19/2005	c2	-	-	-	-	-	x	x	-	x	-	-	x	-	x	-	x	x	-	x	x
TWSW-1E	TW-10002	0	25	CATW-00-0003	SED	-	6/23/2000	f1	x	-	x	-	x	-	x	x	-	x	x	-	x	-	x	-	-	x	-	-
TWSW-1E	TW-10002	0	25	CATW-05-62396	SED	-	7/19/2005	f1	-	-	-	-	-	x	x	-	x	-	-	x	-	x	-	x	x	-	x	x
TWSW-1E	TW-10002	25	40	CATW-00-0004	SED	-	6/23/2000	f1	x	-	x	-	x	-	x	x	-	x	x	-	x	-	x	-	-	x	-	-
TWSW-1E	TW-10002	25	40	CATW-05-62397	SED	-	7/19/2005	f1	-	-	-	-	-	x	x	-	x	-	-	x	-	x	-	x	x	-	x	x
TWSW-1E	TW-10003	0	15	CATW-00-0005	SED	-	6/23/2000	c2? [f1?]	x	-	x	-	x	-	x	x	-	x	x	-	x	-	x	-	-	x	-	-
TWSW-1E	TW-10004	3	12	CATW-00-0006	SED	-	6/23/2000	c2	x	-	x	-	x	-	x	x	-	x	x	-	x	-	x	-	-	x	-	-
TWSW-1E	TW-24932	26	47	CATW-05-62366	SED	-	7/19/2005	c2	x	-	x	-	x	x	x	x	-	x	x	x	x	x	x	x	x	x	x	x
TWSW-1E	TW-24933	0	24	CATW-05-62367	SED	-	7/19/2005	c2	x	-	x	-	x	x	x	x	x	x	x	x	x	x	x	x	x	x	x	x

Table C-2.0-1 (continued)

Reach	Location ID	Top Depth (cm)	Bottom Depth (cm)	Sample ID	Media Code	Field Code	Collection Date	Geomorphic Unit	Am-241	Anion	CN	Dioxin/Furan	Gamma Spec	H3	HEXP	Iso Pu	Iso Th	Iso U	Metals	PAH	PCB	Perchlorate	PEST	pH	Sr-90	SVOC	VOC	Wet Chem
TWSW-1E	TW-24933	0	24	CATW-05-62364	SED	Field Duplicate	7/19/2005	c2	x	-	x	-	x	x	x	x	-	x	x	x	x	x	-	x	x	x	x	-
TWSW-1E	TW-24933	24	41	CATW-05-62368	SED	-	7/19/2005	c2	x	-	x	-	x	x	x	x	-	x	x	x	x	x	x	x	x	x	x	x
TWSW-1E	TW-24935	0	20	CATW-05-62369	SED	-	7/19/2005	c1	x	-	x	-	x	x	x	x	-	x	x	x	x	x	x	x	x	x	x	x
TWSW-1E	TW-24936	0	22	CATW-05-62370	SED	-	7/19/2005	c2	x	-	x	-	x	x	x	x	-	x	x	x	x	x	x	x	x	x	x	x
TWSW-1E	TW-24937	6	30	CATW-05-62371	SED	-	7/19/2005	c2	x	-	x	-	x	x	x	x	-	x	x	x	x	x	x	x	x	x	x	x
TWSW-1W	TW-26531	6	21	CATW-06-71089	SED	-	6/22/2006	c2	x	-	x	-	x	x	x	x	-	x	x	x	x	-	-	-	-	-	-	-
TWSW-1W	TW-26532	0	25	CATW-06-71090	SED	-	6/22/2006	c2	x	-	x	-	x	x	x	x	-	x	x	x	x	-	-	-	-	-	-	-
TWSW-1W	TW-26533	0	5	CATW-06-71091	SED	-	6/22/2006	c1	x	-	x	-	x	x	x	x	-	x	x	x	x	-	-	-	-	-	-	-
TWSW-1W	TW-26534	0	17	CATW-06-71092	SED	-	6/22/2006	f1	x	-	x	-	x	x	x	x	-	x	x	x	x	-	-	-	-	-	-	-
TWSW-1W	TW-26535	0	21	CATW-06-71093	SED	-	6/22/2006	f1	x	-	x	-	x	x	x	x	-	x	x	x	x	-	-	-	-	-	-	-
TWSW-1W	TW-26536	9	34	CATW-06-71094	SED	-	6/22/2006	c2	x	-	x	-	x	x	x	x	-	x	x	x	x	-	-	-	-	-	-	-
TWSW-1W	TW-26537	0	18	CATW-06-71095	SED	-	6/22/2006	c2	x	-	x	-	x	x	x	x	-	x	x	x	x	-	-	-	-	-	-	-
TWSW-1W	TW-26538	6	41	CATW-06-71096	SED	-	6/22/2006	f1	x	-	x	-	x	x	x	x	-	x	x	x	x	-	-	-	-	-	-	-
TWSW-1W	TW-26539	0	22	CATW-06-71097	SED	-	6/22/2006	f1	x	-	x	-	x	x	x	x	-	x	x	x	x	-	-	-	-	-	-	-
TWSW-1W	TW-26539	0	22	CATW-06-71099	SED	Field Duplicate	6/22/2006	f1	x	-	x	-	x	x	x	x	-	x	x	x	x	-	-	-	-	-	-	-
TWSW-1W	TW-26540	0	28	CATW-06-71098	SED	-	6/22/2006	c2	x	-	x	-	x	x	x	x	-	x	x	x	x	-	-	-	-	-	-	-

^a x = Analysis was performed.
^b - = Analysis was not performed.

**Table C-2.0-2
Pajarito Canyon Watershed Surface Water Samples Collected**

Location ID	Media Description	Sample ID	Field Prep	Field QC Type	Collection Date	DIOX/FUR	DRO	GENINORG	HERB	HEXP	Metals	PEST/PCB	RAD	SVOA	VOA
Flood Water Over Bank Pajarito at G-1	WT	PF00061EPG1	Filtered	-	6/28/2000	- ^a	-	-	-	-	-	-	x ^b	-	-
Flood Water Over Bank Pajarito at G-1	WT	PS00061EPG1	Unfiltered	-	6/28/2000	-	-	x	-	-	-	-	x	-	-
Flood Water Over Bank Pajarito at G-1	WT	PS00062EPG1	Unfiltered	Field Duplicate	6/28/2000	-	-	x	-	-	-	-	-	-	-
La Delfe above Pajarito	WT	GU0206E242501	Unfiltered	-	6/21/2002	-	-	x	-	-	x	-	-	-	-
La Delfe above Pajarito	WT	GU0207E242501	Unfiltered	-	7/14/2002	-	-	x	-	x	x	-	x	-	-
La Delfe above Pajarito	WT	GU0207E242501TSSM	Unfiltered	-	7/14/2002	-	-	x	-	-	-	-	-	-	-
La Delfe above Pajarito	WS	GF0406W242501	Filtered	-	6/16/2004	-	-	x	-	-	x	-	-	-	-
La Delfe above Pajarito	WS	GU0406W242501	Unfiltered	-	6/16/2004	-	-	x	-	x	x	-	-	x	x
La Delfe above Pajarito	WT	GF0407E242501	Filtered	-	7/24/2004	-	-	x	-	-	x	-	-	-	-
La Delfe above Pajarito	WT	GU0407E242501	Unfiltered	-	7/24/2004	-	-	x	-	x	x	-	-	-	-
La Delfe above Pajarito	WM	GF0503M242501	Filtered	-	3/24/2005	-	-	x	-	-	-	-	-	-	-
La Delfe above Pajarito	WM	GU0503M242501	Unfiltered	-	3/24/2005	-	-	x	-	x	x	-	-	-	-
La Delfe above Pajarito	WS	GF0506P242501	Filtered	-	6/14/2005	-	-	x	-	-	x	-	-	-	-
La Delfe above Pajarito	WS	GU0506P242501	Unfiltered	-	6/14/2005	-	-	x	-	x	x	-	-	x	x
La Delfe above Pajarito	WT	GF0507E242501	Filtered	-	7/15/2005	-	-	x	-	-	x	-	-	-	-

Table C-2.0-2 (continued)

Location ID	Media Description	Sample ID	Field Prep	Field QC Type	Collection Date	DIOX/FUR	DRO	GENINORG	HERB	HEXP	Metals	PEST/PCB	RAD	SVOA	VOA
La Delfe above Pajarito	WT	GU0507E242501	Unfiltered	-	7/15/2005	-	-	x	-	x	x	-	-	-	-
La Delfe above Pajarito	WT	GF0508E242501	Filtered	-	8/4/2005	-	-	x	-	-	x	-	-	-	-
La Delfe above Pajarito	WT	GU0508E242501	Unfiltered	-	8/4/2005	-	-	x	-	x	x	-	-	-	-
La Delfe above Pajarito	WT	GF0508E242502	Filtered	-	8/6/2005	-	-	x	-	-	x	-	-	-	-
La Delfe above Pajarito	WT	GU0508E242502	Unfiltered	-	8/6/2005	-	-	x	-	x	x	-	-	-	-
La Delfe above Pajarito	WT	GF0508E242503	Filtered	-	8/12/2005	-	-	x	-	-	x	-	-	-	-
La Delfe above Pajarito	WT	GU0508E242503	Unfiltered	-	8/12/2005	-	-	x	-	x	x	-	-	-	-
La Delfe above Pajarito	WT	GF06080E242501	Filtered	-	8/8/2006	-	-	x	-	-	x	-	-	-	-
La Delfe above Pajarito	WT	GU06080E242501	Unfiltered	-	8/8/2006	-	-	x	-	x	x	-	-	-	-
La Delfe above Pajarito	WT	GF06090E242501	Filtered	-	8/25/2006	-	-	x	-	-	x	-	-	-	-
La Delfe above Pajarito	WT	GU06090E242501	Unfiltered	-	8/25/2006	-	-	x	-	x	x	-	-	-	-
La Delfe above Pajarito	WT	GF06090E242502	Filtered	-	9/11/2006	-	-	x	-	-	x	-	-	-	-
La Delfe above Pajarito	WT	GU06090E242502	Unfiltered	-	9/11/2006	-	-	x	-	x	x	-	-	-	-
La Delfe above Pajarito	WT	GF07070E242501	Filtered	-	7/14/2007	-	-	x	-	-	x	-	-	-	-
La Delfe above Pajarito	WT	GU07070E242501	Unfiltered	-	7/14/2007	-	-	x	-	x	x	-	x	-	-
La Delfe above Pajarito	WT	GF07070E242502	Filtered	-	7/26/2007	-	-	x	-	-	x	-	-	-	-

Table C-2.0-2 (continued)

Location ID	Media Description	Sample ID	Field Prep	Field QC Type	Collection Date	DIOX/FUR	DRO	GENINORG	HERB	HEXP	Metals	PEST/PCB	RAD	SVOA	VOA
La Delfe above Pajarito	WT	GU07070E242502	Unfiltered	-	7/26/2007	-	-	x	-	x	x	-	-	-	-
La Delfe above Pajarito	WT	GF07080E242501	Filtered	-	8/29/2007	-	-	x	-	-	x	-	-	-	-
La Delfe above Pajarito	WT	GU07080E242501	Unfiltered	-	8/29/2007	-	-	x	-	x	x	-	x	-	-
La Delfe above Pajarito	WT	GF07090E242501	Filtered	-	8/31/2007	-	-	x	-	-	x	-	-	-	-
La Delfe above Pajarito	WT	GU07090E242501	Unfiltered	-	8/31/2007	-	-	x	-	x	x	-	x	-	-
La Delfe above Pajarito	WT	GU07120E242501	Unfiltered	-	12/1/2007	-	-	-	-	-	-	-	x	-	-
PA-0.01	WS	WS9703277661	Filtered	-	3/27/1997	-	-	x	-	-	x	-	x	-	-
PA-0.01	WS	WS9703277661	Unfiltered	-	3/27/1997	-	-	-	-	-	x	-	-	-	-
PA-10.4	WS	WS9703277671	Filtered	-	3/27/1997	-	-	x	-	-	x	-	-	-	-
PA-10.4	WS	WS9703277671	Unfiltered	-	3/27/1997	-	-	-	-	-	x	-	-	-	-
PA-10.4	WS	WS9705017671	Filtered	-	5/1/1997	-	-	x	-	-	x	-	-	-	-
PA-10.4	WS	WS9705017671	Unfiltered	-	5/1/1997	-	-	-	-	-	x	-	-	-	-
PA-10.8	WS	WS9702247681	Filtered	-	2/24/1997	-	-	x	-	-	x	-	x	-	-
PA-10.8	WS	WS9702247681	Unfiltered	-	2/24/1997	-	-	-	-	-	x	-	-	-	-
PA-8.9	WS	WS9702077691	Filtered	-	2/7/1997	-	-	x	-	-	x	-	x	-	-
PA-8.9	WS	WS9702077691	Unfiltered	-	2/7/1997	-	-	-	-	x	x	-	-	-	x
Pajarito 0.5 mi above SR-501	WS	GF04060WBF101	Filtered	-	6/15/2004	-	-	x	-	-	x	-	-	-	-

Table C-2.0-2 (continued)

Location ID	Media Description	Sample ID	Field Prep	Field QC Type	Collection Date	DIOX/FUR	DRO	GENINORG	HERB	HEXP	Metals	PEST/PCB	RAD	SVOA	VOA
Pajarito 0.5 mi above SR-501	WS	GU04060WBF101	Unfiltered	-	6/15/2004	-	-	x	-	x	x	-	-	x	x
Pajarito 0.5 mi above SR-501	WS	GF05060PBF101	Filtered	-	6/14/2005	-	-	x	-	-	x	-	-	-	-
Pajarito 0.5 mi above SR-501	WS	GU05060PBF101	Unfiltered	-	6/14/2005	-	-	x	-	x	x	-	-	x	x
Pajarito 0.5 mi above SR-501	WP	GF060800PBF101	Filtered	-	8/28/2006	-	-	x	-	-	x	-	x	-	-
Pajarito 0.5 mi above SR-501	WP	GU060800PBF101	Filtered	-	8/28/2006	-	-	x	-	-	-	-	-	-	-
Pajarito 0.5 mi above SR-501	WP	GU060800PBF101	Unfiltered	-	8/28/2006	-	-	x	x	-	x	x	x	x	x
Pajarito 0.5 mi above SR-501	WP	SU060800PBF101	Unfiltered	-	8/28/2006	-	-	-	-	x	-	-	-	-	-
Pajarito 0.5 mi above SR-501	WP	UU060800PBF101	Unfiltered	-	8/28/2006	-	-	-	-	-	-	-	x	-	-
Pajarito 0.5 mi above SR-501	WS	GF06110PPBFB01	Filtered	-	12/5/2006	-	-	x	-	-	x	-	x	-	-
Pajarito 0.5 mi above SR-501	WS	GF06110PPBFB20	Filtered	Field Duplicate	12/5/2006	-	-	x	-	-	x	-	x	-	-
Pajarito 0.5 mi above SR-501	WS	GU06110PPBFB01	Filtered	-	12/5/2006	-	-	x	-	-	-	-	-	-	-
Pajarito 0.5 mi above SR-501	WS	GU06110PPBFB01	Unfiltered	-	12/5/2006	-	-	x	-	-	x	x	x	x	x
Pajarito 0.5 mi above SR-501	WS	GU06110PPBFB20	Filtered	Field Duplicate	12/5/2006	-	-	x	-	-	-	-	-	-	-
Pajarito 0.5 mi above SR-501	WS	GU06110PPBFB20	Unfiltered	Field Duplicate	12/5/2006	-	-	x	-	-	x	x	x	x	x
Pajarito 0.5 mi above SR-501	WS	SU06110PPBFB01	Unfiltered	-	12/5/2006	-	-	-	-	x	-	-	-	-	-

Table C-2.0-2 (continued)

Location ID	Media Description	Sample ID	Field Prep	Field QC Type	Collection Date	DIOX/FUR	DRO	GENINORG	HERB	HEXP	Metals	PEST/PCB	RAD	SVOA	VOA
Pajarito 0.5 mi above SR-501	WS	SU06110PPBFB20	Unfiltered	Field Duplicate	12/5/2006	-	-	-	-	x	-	-	-	-	-
Pajarito 0.5 mi above SR-501	WS	UU06110PPBFB01	Unfiltered	-	12/5/2006	-	-	-	-	-	-	-	x	-	-
Pajarito 0.5 mi above SR-501	WS	UU06110PPBFB20	Unfiltered	Field Duplicate	12/5/2006	-	-	-	-	-	-	-	x	-	-
Pajarito 0.5 mi above SR-501	WS	GF07030PPBFB01	Filtered	-	3/21/2007	-	-	x	-	-	x	-	x	-	-
Pajarito 0.5 mi above SR-501	WS	GF07030PPBFB20	Filtered	Field Duplicate	3/21/2007	-	-	x	-	-	x	-	x	-	-
Pajarito 0.5 mi above SR-501	WS	GU07030PPBFB01	Unfiltered	-	3/21/2007	-	-	x	-	x	x	x	x	x	x
Pajarito 0.5 mi above SR-501	WS	GU07030PPBFB20	Unfiltered	Field Duplicate	3/21/2007	-	-	x	-	x	x	x	x	x	x
Pajarito 0.5 mi above SR-501	WS	SU07030PPBFB01	Unfiltered	-	3/21/2007	-	-	-	-	x	-	-	-	-	-
Pajarito 0.5 mi above SR-501	WS	UU07030PPBFB01	Unfiltered	-	3/21/2007	-	-	-	-	-	-	-	x	-	-
Pajarito 0.5 mi above SR-501	WS	UU07030PPBFB20	Unfiltered	Field Duplicate	3/21/2007	-	-	-	-	-	-	-	x	-	-
Pajarito 0.5 mi above SR-501	WS	GF07060PPBFB01	Filtered	-	6/28/2007	-	-	x	-	-	x	-	x	-	-
Pajarito 0.5 mi above SR-501	WS	GU07060PPBFB01	Unfiltered	-	6/28/2007	-	-	x	-	x	x	x	x	x	x
Pajarito 0.5 mi above SR-501	WP	SU07060PPBFB01	Unfiltered	-	6/28/2007	-	-	-	-	x	-	-	-	-	-
Pajarito 0.5 mi above SR-501	WS	UU07060PPBFB01	Unfiltered	-	6/28/2007	-	-	-	-	-	-	-	x	-	-

Table C-2.0-2 (continued)

Location ID	Media Description	Sample ID	Field Prep	Field QC Type	Collection Date	DIOX/FUR	DRO	GENINORG	HERB	HEXP	Metals	PEST/PCB	RAD	SVOA	VOA
Pajarito 0.5 mi above SR-501	WP	GF07090PPBFB01	Filtered	-	9/13/2007	-	-	x	-	-	x	-	x	-	-
Pajarito 0.5 mi above SR-501	WP	GU07090PPBFB01	Unfiltered	-	9/13/2007	-	-	x	x	x	x	x	x	x	x
Pajarito 0.5 mi above SR-501	WP	SU07090PPBFB01	Unfiltered	-	9/13/2007	-	-	-	-	x	-	-	-	-	-
Pajarito 0.5 mi above SR-501	WP	UU07090PPBFB01	Unfiltered	-	9/13/2007	-	-	-	-	-	-	-	x	-	-
Pajarito 0.5 mi above SR-501	WS	CAPA-08-9236	Unfiltered	-	12/17/2007	-	-	x	-	x	x	x	x	x	x
Pajarito 0.5 mi above SR-501	WS	CAPA-08-9237	Filtered	-	12/17/2007	-	-	x	-	-	x	-	x	-	-
Pajarito 0.5 mi above SR-501	WS	CAPA-08-9718	Filtered	Field Duplicate	12/17/2007	-	-	x	-	-	x	-	x	-	-
Pajarito 0.5 mi above SR-501	WS	CAPA-08-9719	Unfiltered	Field Duplicate	12/17/2007	-	-	x	-	x	x	x	x	x	x
Pajarito 0.5 mi above SR-501	WS	CAPA-08-11005	Filtered	-	3/19/2008	-	-	x	-	-	x	-	x	-	-
Pajarito 0.5 mi above SR-501	WS	CAPA-08-11006	Unfiltered	-	3/19/2008	-	-	x	-	x	x	x	x	x	x
Pajarito 0.5 mi above SR-501	WS	CAPA-08-11010	Filtered	Field Duplicate	3/19/2008	-	-	x	-	-	x	-	x	-	-
Pajarito 0.5 mi above SR-501	WS	CAPA-08-11011	Unfiltered	Field Duplicate	3/19/2008	-	-	x	-	x	x	x	x	x	x
Pajarito 0.5 mi above SR-501	WS	CAPA-08-13025	Unfiltered	-	6/10/2008	-	-	x	-	x	x	x	x	x	x
Pajarito 0.5 mi above SR-501	WS	CAPA-08-13026	Filtered	-	6/10/2008	-	-	x	-	-	x	-	x	-	-

Table C-2.0-2 (continued)

Location ID	Media Description	Sample ID	Field Prep	Field QC Type	Collection Date	DIOX/FUR	DRO	GENINORG	HERB	HEXP	Metals	PEST/PCB	RAD	SVOA	VOA
Pajarito 0.5 mi above SR-501	WS	CAPA-08-13028	Filtered	Field Duplicate	6/10/2008	-	-	x	-	-	x	-	x	-	-
Pajarito 0.5 mi above SR-501	WS	CAPA-08-13029	Unfiltered	Field Duplicate	6/10/2008	-	-	x	-	x	x	x	x	x	x
Pajarito above SR-4	WT	DF99061E250	Filtered	-	6/17/1999	-	-	x	-	-	x	-	x	-	-
Pajarito above SR-4	WT	DS99061E250	Filtered	-	6/17/1999	-	-	x	-	-	x	-	-	-	-
Pajarito above SR-4	WT	DS99061E250	Unfiltered	-	6/17/1999	-	-	x	-	x	x	x	x	x	-
Pajarito above SR-4	WT	DS99062E250	Unfiltered	-	6/17/1999	-	-	x	-	-	-	-	-	-	-
Pajarito above SR-4	WT	WT9906177861	Unfiltered	-	6/17/1999	-	-	x	-	-	x	-	-	-	-
Pajarito above SR-4	WT	PF00061E250	Filtered	-	6/28/2000	-	-	x	-	-	x	-	x	-	-
Pajarito above SR-4	WT	PS00061E250	Unfiltered	-	6/28/2000	x	-	x	-	x	x	x	x	x	-
Pajarito above SR-4	WT	PS00062E250	Unfiltered	Field Duplicate	6/28/2000	-	-	x	-	-	-	-	-	-	-
Pajarito above SR-4	WT	GF00101E250	Filtered	-	10/24/2000	-	-	x	-	-	x	-	x	-	-
Pajarito above SR-4	WT	GS00101E250	Filtered	-	10/24/2000	-	-	x	-	-	-	-	-	-	-
Pajarito above SR-4	WT	GS00101E250	Unfiltered	-	10/24/2000	x	-	x	-	x	x	x	x	x	x
Pajarito above SR-4	WT	GS00102E250	Unfiltered	Field Duplicate	10/24/2000	-	-	x	-	-	-	-	-	-	-
Pajarito above SR-4	WT	GF00103E250	Filtered	-	10/27/2000	-	-	x	-	-	x	-	x	-	-

Table C-2.0-2 (continued)

Location ID	Media Description	Sample ID	Field Prep	Field QC Type	Collection Date	DIOX/FUR	DRO	GENINORG	HERB	HEXP	Metals	PEST/PCB	RAD	SVOA	VOA
Pajarito above SR-4	WT	GS00103E250	Filtered	-	10/27/2000	-	-	x	-	-	-	-	-	-	-
Pajarito above SR-4	WT	GS00103E250	Unfiltered	-	10/27/2000	-	-	x	-	x	x	-	x	-	-
Pajarito above SR-4	WT	GS00104E250	Unfiltered	-	10/28/2000	-	-	x	-	-	-	-	-	-	-
Pajarito above SR-4	WM	GF01031E250	Filtered	-	3/21/2001	-	-	x	-	-	x	-	x	-	-
Pajarito above SR-4	WM	GU01031E250	Unfiltered	-	3/21/2001	x	-	x	-	x	x	x	x	x	x
Pajarito above SR-4	WM	GF01041E250	Filtered	-	4/4/2001	-	-	x	-	-	x	-	x	-	-
Pajarito above SR-4	WM	GU01041E250	Unfiltered	-	4/4/2001	x	-	x	-	x	x	x	x	x	x
Pajarito above SR-4	WM	GF01041E0250	Filtered	-	4/18/2001	-	-	x	-	-	x	-	x	-	-
Pajarito above SR-4	WM	GU01041E250-2	Unfiltered	-	4/18/2001	x	-	x	-	x	x	x	x	x	x
Pajarito above SR-4	WM	GF01051E250	Filtered	-	5/2/2001	-	-	x	-	-	x	-	x	-	-
Pajarito above SR-4	WM	GU01051E250	Unfiltered	-	5/2/2001	x	-	x	-	x	x	x	x	x	x
Pajarito above SR-4	WT	GF01061E250	Filtered	-	6/27/2001	-	-	x	-	-	x	-	x	-	-
Pajarito above SR-4	WT	GU01061E250	Unfiltered	-	6/27/2001	-	-	x	-	-	x	-	x	-	-
Pajarito above SR-4	WT	GU01061E250TSSM	Unfiltered	-	6/27/2001	-	-	x	-	-	-	-	-	-	-
Pajarito above SR-4	WT	GF01082E250	Filtered	-	8/6/2001	-	-	x	-	-	x	-	x	-	-
Pajarito above SR-4	WT	GU01082E250	Unfiltered	-	8/6/2001	-	-	x	-	-	x	-	x	-	-
Pajarito above SR-4	WT	GU01082E250TSSM	Unfiltered	-	8/6/2001	-	-	x	-	-	-	-	-	-	-

Table C-2.0-2 (continued)

Location ID	Media Description	Sample ID	Field Prep	Field QC Type	Collection Date	DIOX/FUR	DRO	GENINORG	HERB	HEXP	Metals	PEST/PCB	RAD	SVOA	VOA
Pajarito above SR-4	WT	GF01083E250	Filtered	-	8/9/2001	-	-	x	-	-	x	-	x	-	-
Pajarito above SR-4	WT	GU01083E250	Unfiltered	-	8/9/2001	-	-	x	-	-	x	-	x	-	-
Pajarito above SR-4	WT	GU01083E250TSSM	Unfiltered	-	8/9/2001	-	-	x	-	-	-	-	-	-	-
Pajarito above SR-4	WT	GF01084E250	Filtered	-	8/16/2001	-	-	x	-	-	x	-	x	-	-
Pajarito above SR-4	WT	GU01084E250	Unfiltered	-	8/16/2001	-	-	x	-	-	x	-	x	-	-
Pajarito above SR-4	WT	GU01084E250TSSM	Unfiltered	-	8/16/2001	-	-	x	-	-	-	-	-	-	-
Pajarito above SR-4	WT	GU02060E25002	Unfiltered	-	6/22/2002	-	-	-	-	x	-	x	-	x	-
Pajarito above SR-4	WT	GU02060E25001	Unfiltered	-	6/22/2002	-	-	x	-	-	x	-	-	-	-
Pajarito above SR-4	WT	GU0208E250E01	Unfiltered	-	8/28/2002	-	-	x	-	-	-	-	-	-	-
Pajarito above SR-4	WT	GU04040E25002	Unfiltered	-	4/8/2004	-	-	x	-	-	x	-	x	-	-
Pajarito above SR-4	WT	GF04040E25001	Filtered	-	4/8/2004	-	-	x	-	-	x	-	-	-	-
Pajarito above SR-4	WT	GU04040E25001	Unfiltered	-	4/8/2004	x	-	x	-	x	x	x	-	-	-
Pajarito above SR-4	WM	GF05030M25001	Filtered	-	3/23/2005	-	-	x	-	-	-	-	-	-	-
Pajarito above SR-4	WM	GU05030M25001	Unfiltered	-	3/23/2005	x	-	x	-	x	x	x	x	-	-
Pajarito above SR-4	WT	GF05080E25001	Filtered	-	8/12/2005	-	-	x	-	-	x	-	-	-	-
Pajarito above SR-4	WT	GU05080E25001	Unfiltered	-	8/12/2005	x	-	x	-	x	x	x	-	-	-
Pajarito above SR-4	WT	GF060900E25001	Filtered	-	8/25/2006	-	-	x	-	-	x	-	-	-	-

Table C-2.0-2 (continued)

Location ID	Media Description	Sample ID	Field Prep	Field QC Type	Collection Date	DIOX/FUR	DRO	GENINORG	HERB	HEXP	Metals	PEST/PCB	RAD	SVOA	VOA
Pajarito above SR-4	WT	GU060900E25001	Unfiltered	-	8/25/2006	-	-	x	-	x	x	x	x	-	-
Pajarito above SR-4	WM	AU070300M25001	Unfiltered	-	3/12/2007	x	-	-	-	-	-	-	-	-	-
Pajarito above SR-4	WM	GF070300M25001	Filtered	-	3/12/2007	-	-	x	-	-	x	-	-	-	-
Pajarito above SR-4	WM	GU070300M25001	Unfiltered	-	3/12/2007	-	-	x	-	x	x	x	x	-	-
Pajarito above SR-4	WT	AU070900E25001	Unfiltered	-	9/6/2007	x	-	-	-	-	-	-	-	-	-
Pajarito above SR-4	WT	GF070900E25001	Filtered	-	9/6/2007	-	-	x	-	-	x	-	-	-	-
Pajarito above SR-4	WT	GU070900E25001	Unfiltered	-	9/6/2007	-	-	x	-	x	x	x	x	-	-
Pajarito above SR-4	WT	AU071200E25001	Unfiltered	-	12/1/2007	x	-	-	-	-	-	-	-	-	-
Pajarito above SR-4	WT	GF071200E25001	Filtered	-	12/1/2007	-	-	x	-	-	x	-	-	-	-
Pajarito above SR-4	WT	GU071200E25001	Unfiltered	-	12/1/2007	-	-	x	-	x	x	x	-	-	-
Pajarito above SR-4	WM	GF080200M25001	Filtered	-	1/29/2008	-	-	x	-	-	x	-	-	-	-
Pajarito above SR-4	WM	GU080200M25001	Unfiltered	-	1/29/2008	-	-	x	-	-	x	-	x	-	-
Pajarito above Starmers	WT	PF00061E241	Filtered	-	6/28/2000	-	-	x	-	-	x	-	x	-	-
Pajarito above Starmers	WT	PS00061E241	Unfiltered	-	6/28/2000	-	-	x	-	-	x	x	x	-	-
Pajarito above Starmers	WT	PS00062E241	Unfiltered	Field Duplicate	6/28/2000	-	-	x	-	-	-	-	-	-	-
Pajarito above Starmers	WT	GF01071E241	Filtered	-	7/26/2001	-	-	-	-	-	-	-	x	-	-
Pajarito above Starmers	WT	GU01071E241	Unfiltered	-	7/26/2001	-	-	x	-	-	-	-	x	-	-

Table C-2.0-2 (continued)

Location ID	Media Description	Sample ID	Field Prep	Field QC Type	Collection Date	DIOX/FUR	DRO	GENINORG	HERB	HEXP	Metals	PEST/PCB	RAD	SVOA	VOA
Pajarito above Starmers	WT	GU01071E241TSSM	Unfiltered	-	7/26/2001	-	-	x	-	-	-	-	-	-	-
Pajarito above Starmers	WT	GF01082E241	Filtered	-	8/5/2001	-	-	x	-	-	x	-	-	-	-
Pajarito above Starmers	WT	GU01082E241	Unfiltered	-	8/5/2001	-	-	x	-	-	x	-	x	-	-
Pajarito above Starmers	WT	GU01082E241TSSM	Unfiltered	-	8/5/2001	-	-	x	-	-	-	-	-	-	-
Pajarito above Starmers	WT	GF01083E241	Filtered	-	8/11/2001	-	-	x	-	-	x	-	-	-	-
Pajarito above Starmers	WT	GU01083E241	Unfiltered	-	8/11/2001	-	-	x	-	-	x	-	x	-	-
Pajarito above Starmers	WT	GU01083E241TSSM	Unfiltered	-	8/11/2001	-	-	x	-	-	-	-	-	-	-
Pajarito above Starmers	WT	GU02070E24101	Unfiltered	-	7/25/2002	-	-	x	-	-	-	-	x	-	-
Pajarito above Starmers	WT	GU02070E24101TSSM	Unfiltered	-	7/25/2002	-	-	x	-	-	-	-	-	-	-
Pajarito above Starmers	WT	GF02080E24101	Filtered	-	8/8/2002	-	-	x	-	-	x	-	-	-	-
Pajarito above Starmers	WT	GU02080E24101	Unfiltered	-	8/8/2002	-	-	x	-	-	x	-	-	-	-
Pajarito above Starmers	WT	GU02080E24101TSSM	Unfiltered	-	8/8/2002	-	-	x	-	-	-	-	-	-	-
Pajarito above Starmers	WT	GF02090E24101	Filtered	-	9/9/2002	-	-	-	-	-	-	-	x	-	-
Pajarito above Starmers	WT	GU02090E24101	Unfiltered	-	9/9/2002	-	-	x	-	-	-	-	x	-	-
Pajarito above Starmers	WT	GF03080E24101	Filtered	-	8/11/2003	-	-	x	-	-	-	-	-	-	-
Pajarito above Starmers	WT	GU03080E24101	Unfiltered	-	8/11/2003	-	-	x	-	-	-	-	x	-	-
Pajarito above Starmers	WT	GF03090E24101	Filtered	-	8/23/2003	-	-	x	-	-	-	-	-	-	-

Table C-2.0-2 (continued)

Location ID	Media Description	Sample ID	Field Prep	Field QC Type	Collection Date	DIOX/FUR	DRO	GENINORG	HERB	HEXP	Metals	PEST/PCB	RAD	SVOA	VOA
Pajarito above Starmers	WT	GF03080E24102	Filtered	-	8/23/2003	-	-	x	-	-	x	-	-	-	-
Pajarito above Starmers	WT	GU03080E24102	Unfiltered	-	8/23/2003	-	-	x	-	-	x	-	x	-	-
Pajarito above Starmers	WT	GU03090E24101	Unfiltered	-	8/28/2003	-	-	x	-	-	-	-	-	-	-
Pajarito above Starmers	WS	GF04060W24101	Filtered	-	6/16/2004	-	-	x	-	-	x	-	-	-	-
Pajarito above Starmers	WS	GU04060W24101	Unfiltered	-	6/16/2004	-	-	x	-	x	x	-	-	-	-
Pajarito above Starmers	WT	GF04100E24101	Filtered	-	10/5/2004	-	-	x	-	-	x	-	-	-	-
Pajarito above Starmers	WT	GU04100E24101	Unfiltered	-	10/5/2004	-	-	x	-	-	x	-	-	-	-
Pajarito above Starmers	WM	GF05030M24101	Filtered	-	3/24/2005	-	-	x	-	-	-	-	-	-	-
Pajarito above Starmers	WM	GU05030M24101	Unfiltered	-	3/24/2005	-	-	x	-	-	x	-	-	-	-
Pajarito above Starmers	WS	GF05060P24101	Filtered	-	6/13/2005	-	-	x	-	-	x	-	-	-	-
Pajarito above Starmers	WS	GF05060P24190	Filtered	Field Duplicate	6/13/2005	-	-	x	-	-	x	-	-	-	-
Pajarito above Starmers	WS	GU05060P24101	Unfiltered	-	6/13/2005	-	-	x	-	x	x	-	-	-	-
Pajarito above Starmers	WS	GU05060P24190	Unfiltered	Field Duplicate	6/13/2005	-	-	x	-	x	x	-	-	-	-
Pajarito above Starmers	WT	GF05070E24101	Filtered	-	7/15/2005	-	-	x	-	-	x	-	-	-	-
Pajarito above Starmers	WT	GU05070E24101	Unfiltered	-	7/15/2005	-	-	x	-	-	x	-	-	-	-
Pajarito above Starmers	WT	GF05080E24101	Filtered	-	8/4/2005	-	-	x	-	-	x	-	-	-	-

Table C-2.0-2 (continued)

Location ID	Media Description	Sample ID	Field Prep	Field QC Type	Collection Date	DIOX/FUR	DRO	GENINORG	HERB	HEXP	Metals	PEST/PCB	RAD	SVOA	VOA
Pajarito above Starmers	WT	GU05080E24101	Unfiltered	-	8/4/2005	-	-	x	-	-	x	-	-	-	-
Pajarito above Starmers	WT	GF05080E24102	Filtered	-	8/6/2005	-	-	x	-	-	x	-	-	-	-
Pajarito above Starmers	WT	GU05080E24102	Unfiltered	-	8/6/2005	-	-	x	-	-	x	-	-	-	-
Pajarito above Starmers	WT	GF05080E24103	Filtered	-	8/22/2005	-	-	x	-	-	x	-	-	-	-
Pajarito above Starmers	WT	GU05080E24103	Unfiltered	-	8/22/2005	-	-	x	-	-	x	-	-	-	-
Pajarito above Starmers	WT	GF060800E24101	Filtered	-	8/20/2006	-	-	x	-	-	x	-	-	-	-
Pajarito above Starmers	WT	GU060800E24101	Unfiltered	-	8/20/2006	-	-	x	-	-	x	-	-	-	-
Pajarito above Starmers	WT	GF060900E24101	Filtered	-	8/25/2006	-	-	x	-	-	x	-	-	-	-
Pajarito above Starmers	WT	GU060900E24101	Unfiltered	-	8/25/2006	-	-	x	-	-	x	-	-	-	-
Pajarito above Starmers	WM	GU070300M24101	Unfiltered	-	3/6/2007	-	-	x	-	-	-	-	-	-	-
Pajarito above Starmers	WT	GF070300E24101	Filtered	-	3/26/2007	-	-	x	-	-	x	-	-	-	-
Pajarito above Starmers	WT	GU070300E24102	Unfiltered	-	3/26/2007	-	-	x	-	-	x	-	x	-	-
Pajarito above Starmers	WT	GF070700E24101	Filtered	-	7/14/2007	-	-	x	-	-	x	-	-	-	-
Pajarito above Starmers	WT	GU070700E24101	Unfiltered	-	7/14/2007	-	-	x	-	-	x	-	-	-	-
Pajarito above Starmers	WT	GF070700E24102	Filtered	-	7/26/2007	-	-	x	-	-	x	-	-	-	-
Pajarito above Starmers	WT	GU070700E24102	Unfiltered	-	7/26/2007	-	-	x	-	-	x	-	-	-	-
Pajarito above Starmers	WT	GF070700E24103	Filtered	-	7/30/2007	-	-	x	-	-	x	-	-	-	-

Table C-2.0-2 (continued)

Location ID	Media Description	Sample ID	Field Prep	Field QC Type	Collection Date	DIOX/FUR	DRO	GENINORG	HERB	HEXP	Metals	PEST/PCB	RAD	SVOA	VOA
Pajarito above Starmers	WT	GU070700E24103	Unfiltered	-	7/30/2007	-	-	x	-	-	x	-	x	-	-
Pajarito above Starmers	WT	GU070800E24101	Unfiltered	-	8/6/2007	-	-	x	-	-	-	-	x	-	-
Pajarito above Starmers	WT	GU070800E24102	Unfiltered	-	8/18/2007	-	-	x	-	-	x	-	x	-	-
Pajarito above TA-18	WT	GF01071E245	Filtered	-	7/2/2001	-	-	x	-	-	x	-	x	-	-
Pajarito above TA-18	WT	GU01071E245	Unfiltered	-	7/2/2001	-	-	x	-	-	x	-	x	-	-
Pajarito above TA-18	WT	GU01071E245TSSM	Unfiltered	-	7/2/2001	-	-	x	-	-	-	-	-	-	-
Pajarito above TA-18	WT	GF01083E245	Filtered	-	8/5/2001	-	-	x	-	-	x	-	-	-	-
Pajarito above TA-18	WT	GU01083E245	Unfiltered	-	8/5/2001	-	-	x	-	-	x	-	-	-	-
Pajarito above TA-18	WT	GU01083E245TSSM	Unfiltered	-	8/5/2001	-	-	x	-	-	-	-	-	-	-
Pajarito above TA-18	WM	GF04040M24501	Filtered	-	4/26/2004	-	-	x	-	-	x	-	-	-	-
Pajarito above TA-18	WM	GU04040M24501	Unfiltered	-	4/26/2004	-	-	x	-	x	x	x	x	-	-
Pajarito above TA-18	WT	GF04070E24501	Filtered	-	7/27/2004	-	-	x	-	-	x	-	-	-	-
Pajarito above TA-18	WT	GU04070E24501	Unfiltered	-	7/27/2004	-	-	x	-	x	x	x	x	-	-
Pajarito above TA-18	WT	GF04100E24501	Filtered	-	10/11/2004	-	-	x	-	-	x	-	-	-	-
Pajarito above TA-18	WT	GU04100E24501	Unfiltered	-	10/11/2004	-	-	x	-	x	x	x	x	-	-
Pajarito above TA-18	WM	GF05030M24501	Filtered	-	3/21/2005	-	-	x	-	-	-	-	-	-	-
Pajarito above TA-18	WM	GU05030M24501	Unfiltered	-	3/21/2005	-	-	x	-	x	x	x	x	-	-

Table C-2.0-2 (continued)

Location ID	Media Description	Sample ID	Field Prep	Field QC Type	Collection Date	DIOX/FUR	DRO	GENINORG	HERB	HEXP	Metals	PEST/PCB	RAD	SVOA	VOA
Pajarito above TA-18	WT	GF05070E24501	Filtered	-	7/15/2005	-	-	x	-	-	x	-	-	-	-
Pajarito above TA-18	WT	GU05070E24501	Unfiltered	-	7/15/2005	-	-	x	-	x	x	-	x	-	-
Pajarito above TA-18	WT	GF05080E24501	Filtered	-	8/4/2005	-	-	x	-	-	x	-	-	-	-
Pajarito above TA-18	WT	GU05080E24501	Unfiltered	-	8/4/2005	-	-	x	-	x	x	x	x	-	-
Pajarito above TA-18	WT	GU05080E24502	Unfiltered	-	8/6/2005	-	-	x	-	-	-	-	x	-	-
Pajarito above TA-18	WT	GF05080E24502	Filtered	-	8/12/2005	-	-	x	-	-	x	-	-	-	-
Pajarito above TA-18	WT	GU05080E24503	Unfiltered	-	8/12/2005	-	-	x	-	-	x	x	-	-	-
Pajarito above TA-18	WT	GF05080E24503	Filtered	-	8/24/2005	-	-	x	-	-	x	-	-	-	-
Pajarito above TA-18	WT	GU05080E24504	Unfiltered	-	8/24/2005	-	-	x	-	x	x	-	x	-	-
Pajarito above TA-18	WT	GF05080E24504	Filtered	-	8/25/2005	-	-	x	-	-	-	-	-	-	-
Pajarito above TA-18	WT	GU05080E24505	Unfiltered	-	8/25/2005	-	-	x	-	x	-	x	x	-	-
Pajarito above TA-18	WT	GF060700E24501	Filtered	-	6/29/2006	-	-	x	-	-	x	-	-	-	-
Pajarito above TA-18	WT	GU060700E24501	Unfiltered	-	6/29/2006	-	-	x	-	x	x	-	x	-	-
Pajarito above TA-18	WT	GF060800E24501	Filtered	-	8/28/2006	-	-	x	-	-	x	-	-	-	-
Pajarito above TA-18	WT	GU060800E24501	Unfiltered	-	8/28/2006	-	-	x	-	x	x	x	x	-	-
Pajarito above TA-18	WT	GF060900E24501	Filtered	-	9/1/2006	-	-	x	-	-	x	-	-	-	-
Pajarito above TA-18	WT	GU060900E24501	Unfiltered	-	9/1/2006	-	-	x	-	x	x	x	x	-	-

Table C-2.0-2 (continued)

Location ID	Media Description	Sample ID	Field Prep	Field QC Type	Collection Date	DIOX/FUR	DRO	GENINORG	HERB	HEXP	Metals	PEST/PCB	RAD	SVOA	VOA
Pajarito above TA-18	WM	GU070300M24501	Unfiltered	-	3/8/2007	-	-	x	-	-	-	-	-	-	-
Pajarito above TA-18	WT	GF070300E24501	Filtered	-	3/23/2007	-	-	x	-	-	x	-	-	-	-
Pajarito above TA-18	WT	GU070300E24501	Unfiltered	-	3/23/2007	-	-	x	-	x	x	-	x	-	-
Pajarito above TA-18	WT	GF070700E24501	Filtered	-	7/26/2007	-	-	x	-	-	x	-	-	-	-
Pajarito above TA-18	WT	GU070700E24501	Unfiltered	-	7/26/2007	-	-	x	-	x	x	-	x	-	-
Pajarito above TA-18	WT	GF070700E24502	Filtered	-	7/30/2007	-	-	x	-	-	x	-	-	-	-
Pajarito above TA-18	WT	GU070700E24502	Unfiltered	-	7/30/2007	-	-	x	-	x	x	-	x	-	-
Pajarito above TA-18	WT	GF070900E24501	Filtered	-	9/5/2007	-	-	x	-	-	x	-	-	-	-
Pajarito above TA-18	WT	GU070900E24501	Unfiltered	-	9/5/2007	-	-	x	-	x	x	-	x	-	-
Pajarito above TA-18	WM	GF080200M24501	Filtered	-	1/29/2008	-	-	x	-	-	x	-	-	-	-
Pajarito above TA-18	WM	GU080200M24501	Unfiltered	-	1/29/2008	-	-	x	-	-	x	-	x	-	-
Pajarito above Threemile	WT	9909WT321	Unfiltered	-	9/16/1999	-	-	x	-	-	x	-	-	-	-
Pajarito above Threemile	WT	DF990912455	Filtered	-	9/16/1999	-	-	-	-	-	x	-	x	-	-
Pajarito above Threemile	WT	DS990912455	Unfiltered	-	9/16/1999	-	-	x	-	-	x	x	x	x	-
Pajarito above Threemile	WT	DS990922455	Unfiltered	-	9/16/1999	-	-	x	-	-	-	-	-	-	-
Pajarito above Threemile	WT	GF0206E245501	Filtered	-	6/21/2002	-	-	x	-	-	x	-	x	-	-
Pajarito above Threemile	WT	GU0206E245501	Unfiltered	-	6/21/2002	-	-	x	-	-	x	-	x	-	-

Table C-2.0-2 (continued)

Location ID	Media Description	Sample ID	Field Prep	Field QC Type	Collection Date	DIOX/FUR	DRO	GENINORG	HERB	HEXP	Metals	PEST/PCB	RAD	SVOA	VOA
Pajarito above Threemile	WT	GU0206E245501TSSM	Unfiltered	-	6/21/2002	-	-	x	-	-	-	-	-	-	-
Pajarito above Threemile	WT	GF0209E245501	Filtered	-	9/10/2002	-	-	x	-	-	x	-	-	-	-
Pajarito above Threemile	WT	GU0209E245501	Unfiltered	-	9/10/2002	-	-	x	-	-	x	-	x	-	-
Pajarito above Threemile	WT	GU0209E245501TSSM	Unfiltered	-	9/10/2002	-	-	x	-	-	-	-	-	-	-
Pajarito above Threemile	WT	GF0309E245501	Filtered	-	9/6/2003	-	-	x	-	-	x	-	x	-	-
Pajarito above Threemile	WT	GU0309E245501	Unfiltered	-	9/6/2003	-	-	x	-	-	x	-	x	-	-
Pajarito above Threemile	WM	GF0404M245501	Filtered	-	4/26/2004	-	-	x	-	-	x	-	-	-	-
Pajarito above Threemile	WM	GU0404M245501	Unfiltered	-	4/26/2004	-	-	x	-	x	x	x	x	-	-
Pajarito above Threemile	WT	GF0407E245501	Filtered	-	7/24/2004	-	-	x	-	-	x	-	-	-	-
Pajarito above Threemile	WT	GU0407E245501	Unfiltered	-	7/24/2004	-	-	x	-	-	x	-	x	-	-
Pajarito above Threemile	WT	GF0408E245501	Filtered	-	8/18/2004	-	-	x	-	-	x	-	-	-	-
Pajarito above Threemile	WT	GU0408E245501	Unfiltered	-	8/18/2004	-	-	x	-	-	x	-	x	-	-
Pajarito above Threemile	WT	GF0410E245501	Filtered	-	10/5/2004	-	-	x	-	-	x	-	-	-	-
Pajarito above Threemile	WT	GU0410E245501	Unfiltered	-	10/5/2004	-	-	x	-	x	x	x	x	-	-
Pajarito above Threemile	WM	GF0503M245501	Filtered	-	3/21/2005	-	-	x	-	-	-	-	-	-	-
Pajarito above Threemile	WM	GU0503M245501	Unfiltered	-	3/21/2005	-	-	x	-	x	x	x	x	-	-
Pajarito above Threemile	WT	GF0507E245501	Filtered	-	7/15/2005	-	-	x	-	-	x	-	-	-	-

Table C-2.0-2 (continued)

Location ID	Media Description	Sample ID	Field Prep	Field QC Type	Collection Date	DIOX/FUR	DRO	GENINORG	HERB	HEXP	Metals	PEST/PCB	RAD	SVOA	VOA
Pajarito above Threemile	WT	GU0507E245501	Unfiltered	-	7/15/2005	-	-	x	-	-	x	-	-	-	-
Pajarito above Threemile	WT	GF0508E245501	Filtered	-	8/6/2005	-	-	x	-	-	-	-	-	-	-
Pajarito above Threemile	WT	GU0508E245501	Unfiltered	-	8/6/2005	-	-	-	-	x	x	x	x	-	-
Pajarito above Threemile	WT	GF0508E245502	Filtered	-	8/12/2005	-	-	x	-	-	x	-	-	-	-
Pajarito above Threemile	WT	GU0508E245502	Unfiltered	-	8/12/2005	-	-	x	-	x	x	x	x	-	-
Pajarito above Threemile	WT	GF0508E245503	Filtered	-	8/22/2005	-	-	x	-	-	x	-	-	-	-
Pajarito above Threemile	WT	GU0508E245503	Unfiltered	-	8/22/2005	-	-	x	-	x	x	x	x	-	-
Pajarito above Threemile	WT	GU0508E245504	Unfiltered	-	8/24/2005	-	-	x	-	-	-	-	x	-	-
Pajarito above Threemile	WT	GF0508E245504	Filtered	-	8/25/2005	-	-	x	-	-	x	-	-	-	-
Pajarito above Threemile	WT	GU0508E245505	Unfiltered	-	8/25/2005	-	-	x	-	x	x	x	x	-	-
Pajarito above Threemile	WT	GF06070E245501	Filtered	-	6/29/2006	-	-	x	-	-	x	-	-	-	-
Pajarito above Threemile	WT	GU06070E245501	Unfiltered	-	6/29/2006	-	-	x	-	x	x	x	x	-	-
Pajarito above Threemile	WT	GF06080E245501	Filtered	-	8/8/2006	-	-	x	-	-	x	-	-	-	-
Pajarito above Threemile	WT	GU06080E245501	Unfiltered	-	8/8/2006	-	-	x	-	-	x	-	x	-	-
Pajarito above Threemile	WT	GF06080E245502	Filtered	-	8/25/2006	-	-	x	-	-	x	-	-	-	-
Pajarito above Threemile	WT	GU06080E245502	Unfiltered	-	8/25/2006	-	-	x	-	-	x	-	x	-	-
Pajarito above Threemile	WM	GU07030M245501	Unfiltered	-	3/27/2007	-	-	x	-	-	-	-	-	-	-

Table C-2.0-2 (continued)

Location ID	Media Description	Sample ID	Field Prep	Field QC Type	Collection Date	DIOX/FUR	DRO	GENINORG	HERB	HEXP	Metals	PEST/PCB	RAD	SVOA	VOA
Pajarito above Threemile	WT	GF07070E245501	Filtered	-	7/14/2007	-	-	x	-	-	x	-	-	-	-
Pajarito above Threemile	WT	GU07070E245501	Unfiltered	-	7/14/2007	-	-	x	-	x	x	x	x	-	-
Pajarito above Threemile	WT	GF07070E245502	Filtered	-	7/26/2007	-	-	x	-	-	x	-	-	-	-
Pajarito above Threemile	WT	GU07070E245502	Unfiltered	-	7/26/2007	-	-	x	-	-	x	-	-	-	-
Pajarito above Threemile	WT	GF07090E245501	Filtered	-	8/29/2007	-	-	x	-	-	x	-	-	-	-
Pajarito above Threemile	WT	GU07090E245501	Unfiltered	-	8/29/2007	-	-	x	-	x	x	x	x	-	-
Pajarito above Threemile	WT	GF07090E245502	Filtered	-	9/6/2007	-	-	x	-	-	x	-	-	-	-
Pajarito above Threemile	WT	GU07090E245502	Unfiltered	-	9/6/2007	-	-	x	-	x	x	x	x	-	-
Pajarito above Threemile	WM	GF08020M245501	Filtered	-	1/29/2008	-	-	x	-	-	x	-	-	-	-
Pajarito above Threemile	WM	GU08020M245501	Unfiltered	-	1/29/2008	-	-	x	-	-	x	-	x	-	-
Pajarito above Twomile	WT	GU02060E24301	Unfiltered	-	6/21/2002	-	-	x	-	-	x	-	-	-	-
Pajarito above Twomile	WM	GF04040M24301	Filtered	-	4/27/2004	-	-	x	-	-	x	-	-	-	-
Pajarito above Twomile	WM	GU04040M24301	Unfiltered	-	4/27/2004	-	-	x	-	x	x	-	x	-	-
Pajarito above Twomile	WM	GF05030M24301	Filtered	-	3/22/2005	-	-	x	-	-	-	-	-	-	-
Pajarito above Twomile	WM	GU05030M24301	Unfiltered	-	3/22/2005	-	-	x	-	x	x	-	x	-	-
Pajarito above Twomile	WT	GF05070E24301	Filtered	-	7/15/2005	-	-	x	-	-	x	-	-	-	-
Pajarito above Twomile	WT	GU05070E24301	Unfiltered	-	7/15/2005	-	-	x	-	-	x	-	x	-	-

Table C-2.0-2 (continued)

Location ID	Media Description	Sample ID	Field Prep	Field QC Type	Collection Date	DIOX/FUR	DRO	GENINORG	HERB	HEXP	Metals	PEST/PCB	RAD	SVOA	VOA
Pajarito above Twomile	WT	GF05080E24301	Filtered	-	8/12/2005	-	-	x	-	-	x	-	-	-	-
Pajarito above Twomile	WT	GU05080E24301	Unfiltered	-	8/12/2005	-	-	-	-	x	x	-	x	-	-
Pajarito above Twomile	WT	GF05080E24302	Filtered	-	8/24/2005	-	-	x	-	-	x	-	-	-	-
Pajarito above Twomile	WT	GU05080E24302	Unfiltered	-	8/24/2005	-	-	x	-	x	x	-	x	-	-
Pajarito above Twomile	WT	GF060800E24302	Filtered	-	8/8/2006	-	-	x	-	-	x	-	-	-	-
Pajarito above Twomile	WT	GU060800E24302	Unfiltered	-	8/8/2006	-	-	x	-	x	x	-	x	-	-
Pajarito above Twomile	WT	GF060800E24303	Filtered	-	8/25/2006	-	-	x	-	-	x	-	-	-	-
Pajarito above Twomile	WT	GU060800E24303	Unfiltered	-	8/25/2006	-	-	x	-	x	x	-	x	-	-
Pajarito above Twomile	WP	GF060800P24301	Filtered	-	8/29/2006	-	-	x	-	-	x	-	x	-	-
Pajarito above Twomile	WP	GU060800P24301	Filtered	-	8/29/2006	-	-	x	-	-	-	-	-	-	-
Pajarito above Twomile	WP	GU060800P24301	Unfiltered	-	8/29/2006	-	-	x	x	-	x	x	x	x	x
Pajarito above Twomile	WP	SU060800P24301	Unfiltered	-	8/29/2006	-	-	-	-	x	-	-	-	-	-
Pajarito above Twomile	WP	UU060800P24301	Unfiltered	-	8/29/2006	-	-	-	-	-	-	-	x	-	-
Pajarito above Twomile	WT	GF060900E24301	Filtered	-	9/11/2006	-	-	x	-	-	x	-	-	-	-
Pajarito above Twomile	WT	GU060900E24301	Unfiltered	-	9/11/2006	-	-	x	-	x	x	-	x	-	-
Pajarito above Twomile	WM	GU070300M24301	Unfiltered	-	3/6/2007	-	-	x	-	-	-	-	x	-	-
Pajarito above Twomile	WS	GF070300P24301	Filtered	-	4/3/2007	-	-	x	-	-	x	-	x	-	-

Table C-2.0-2 (continued)

Location ID	Media Description	Sample ID	Field Prep	Field QC Type	Collection Date	DIOX/FUR	DRO	GENINORG	HERB	HEXP	Metals	PEST/PCB	RAD	SVOA	VOA
Pajarito above Twomile	WS	GU070300P24301	Unfiltered	-	4/3/2007	-	-	x	-	x	x	x	-	x	x
Pajarito above Twomile	WS	GU070300P24302	Unfiltered	-	4/3/2007	-	-	-	-	-	-	-	x	-	-
Pajarito above Twomile	WS	SU070300P24301	Unfiltered	-	4/3/2007	-	-	-	-	x	-	-	-	-	-
Pajarito above Twomile	WS	UU070300P24301	Unfiltered	-	4/3/2007	-	-	-	-	-	-	-	x	-	-
Pajarito above Twomile	WS	GF070600P24301	Filtered	-	6/27/2007	-	-	x	-	-	x	-	x	-	-
Pajarito above Twomile	WS	GF070600P24320	Filtered	Field Duplicate	6/27/2007	-	-	x	-	-	x	-	-	-	-
Pajarito above Twomile	WS	GU070600P24301	Unfiltered	-	6/27/2007	-	-	x	-	x	x	x	x	x	x
Pajarito above Twomile	WS	GU070600P24320	Unfiltered	Field Duplicate	6/27/2007	-	-	x	-	x	x	x	x	x	x
Pajarito above Twomile	WS	SU070600P24301	Unfiltered	-	6/27/2007	-	-	-	-	x	-	-	-	-	-
Pajarito above Twomile	WS	SU070600P24320	Unfiltered	Field Duplicate	6/27/2007	-	-	-	-	x	-	-	-	-	-
Pajarito above Twomile	WP	UU070600P24301	Unfiltered	-	6/27/2007	-	-	-	-	-	-	-	x	-	-
Pajarito above Twomile	WP	UU070600P24320	Unfiltered	Field Duplicate	6/27/2007	-	-	-	-	-	-	-	x	-	-
Pajarito above Twomile	WT	GF070700E24301	Filtered	-	7/14/2007	-	-	x	-	-	x	-	-	-	-
Pajarito above Twomile	WT	GU070700E24301	Unfiltered	-	7/14/2007	-	-	x	-	x	x	-	x	-	-
Pajarito above Twomile	WT	GF070800E24301	Filtered	-	8/29/2007	-	-	x	-	-	x	-	-	-	-

Table C-2.0-2 (continued)

Location ID	Media Description	Sample ID	Field Prep	Field QC Type	Collection Date	DIOX/FUR	DRO	GENINORG	HERB	HEXP	Metals	PEST/PCB	RAD	SVOA	VOA
Pajarito above Twomile	WT	GU070800E24301	Unfiltered	-	8/29/2007	-	-	x	-	x	x	-	x	-	-
Pajarito above Twomile	WT	GF070900E24301	Filtered	-	8/31/2007	-	-	x	-	-	x	-	-	-	-
Pajarito above Twomile	WT	GU070900E24301	Unfiltered	-	8/31/2007	-	-	x	-	x	x	-	x	-	-
Pajarito above Twomile	WT	GF070900E24302	Filtered	-	9/2/2007	-	-	x	-	-	x	-	-	-	-
Pajarito above Twomile	WT	GU070900E24302	Unfiltered	-	9/2/2007	-	-	x	-	-	x	-	x	-	-
Pajarito above Twomile	WP	GF070900P24301	Filtered	-	9/12/2007	-	-	x	-	-	x	-	x	-	-
Pajarito above Twomile	WP	GU070900P24301	Unfiltered	-	9/12/2007	-	-	x	x	x	x	x	x	x	x
Pajarito above Twomile	WP	SU070900P24301	Unfiltered	-	9/12/2007	-	-	-	-	x	-	-	-	-	-
Pajarito above Twomile	WP	UU070900P24301	Unfiltered	-	9/12/2007	-	-	-	-	-	-	-	x	-	-
Pajarito above Twomile	WS	CAPA-08-9270	Unfiltered	-	12/17/2007	-	-	x	-	x	x	x	x	x	x
Pajarito above Twomile	WS	CAPA-08-9271	Filtered	-	12/17/2007	-	-	x	-	-	x	-	x	-	-
Pajarito above Twomile	WM	GF080200M24301	Filtered	-	1/29/2008	-	-	x	-	-	x	-	-	-	-
Pajarito above Twomile	WM	GU080200M24301	Unfiltered	-	1/29/2008	-	-	x	-	-	x	-	x	-	-
Pajarito above Twomile	WS	CAPA-08-11002	Unfiltered	-	3/5/2008	-	-	x	-	x	x	x	x	x	x
Pajarito above Twomile	WS	CAPA-08-11004	Filtered	-	3/5/2008	-	-	x	-	-	x	-	x	-	-
Pajarito above Twomile	WS	CAPA-08-13042	Unfiltered	-	6/12/2008	-	-	x	-	x	x	x	x	x	x
Pajarito above Twomile	WS	CAPA-08-13043	Filtered	-	6/12/2008	-	-	x	-	-	x	-	x	-	-

Table C-2.0-2 (continued)

Location ID	Media Description	Sample ID	Field Prep	Field QC Type	Collection Date	DIOX/FUR	DRO	GENINORG	HERB	HEXP	Metals	PEST/PCB	RAD	SVOA	VOA
Pajarito Acres Lagoon	WS	WS7306227841	Unfiltered	-	6/22/1973	-	-	-	-	-	x	-	x	-	-
Pajarito at Rio Grande	WS	WS6706277701	Filtered	-	6/27/1967	-	-	x	-	-	-	-	-	-	-
Pajarito at Rio Grande	WS	WS6706277701	Unfiltered	-	6/27/1967	-	-	x	-	-	x	-	x	-	-
Pajarito at Rio Grande	WS	7303WSSGRP	Unfiltered	-	3/18/1973	-	-	-	-	-	x	-	x	-	-
Pajarito at Rio Grande	WS	7309WSSGRP	Unfiltered	-	9/11/1973	-	-	-	-	-	x	-	x	-	-
Pajarito at Rio Grande	WS	7410WSSGRP	Filtered	-	10/1/1974	-	-	x	-	-	-	-	-	-	-
Pajarito at Rio Grande	WS	7410WSSGRP	Unfiltered	-	10/1/1974	-	-	x	-	-	x	-	-	-	-
Pajarito at Rio Grande	WS	7709WSSGRP	Filtered	-	9/13/1977	-	-	x	-	-	-	-	-	-	-
Pajarito at Rio Grande	WS	7709WSSGRP	Unfiltered	-	9/13/1977	-	-	x	-	-	-	-	-	-	-
Pajarito at Rio Grande	WS	7801WSSGRP	Unfiltered	-	1/1/1978	-	-	-	-	-	x	-	x	-	-
Pajarito at Rio Grande	WS	7809WSSGRP	Filtered	-	9/19/1978	-	-	x	-	-	x	-	-	-	-
Pajarito at Rio Grande	WS	7809WSSGRP	Unfiltered	-	9/19/1978	-	-	x	-	-	x	-	x	-	-
Pajarito at Rio Grande	WS	7911WSSGRP	Filtered	-	11/1/1979	-	-	x	-	-	x	-	-	-	-
Pajarito at Rio Grande	WS	7911WSSGRP	Unfiltered	-	11/1/1979	-	-	x	-	-	x	-	x	-	-
Pajarito at Rio Grande	WS	8003WSSGRP	Unfiltered	-	3/4/1980	-	-	x	-	-	-	-	-	-	-
Pajarito at Rio Grande	WS	8010WSSGRP	Filtered	-	10/7/1980	-	-	x	-	-	x	-	-	-	-
Pajarito at Rio Grande	WS	8010WSSGRP	Unfiltered	-	10/7/1980	-	-	x	-	-	x	-	x	-	-

Table C-2.0-2 (continued)

Location ID	Media Description	Sample ID	Field Prep	Field QC Type	Collection Date	DIOX/FUR	DRO	GENINORG	HERB	HEXP	Metals	PEST/PCB	RAD	SVOA	VOA
Pajarito at Rio Grande	WS	8110WSSGRP	Filtered	-	10/1/1981	-	-	x	-	-	x	-	-	-	-
Pajarito at Rio Grande	WS	8110WSSGRP	Unfiltered	-	10/1/1981	-	-	x	-	-	x	-	x	-	-
Pajarito at Rio Grande	WS	8209WSSGRP	Filtered	-	9/27/1982	-	-	x	-	-	x	-	-	-	-
Pajarito at Rio Grande	WS	8209WSSGRP	Unfiltered	-	9/27/1982	-	-	x	-	-	x	-	x	-	-
Pajarito at Rio Grande	WS	8409WSSGRP	Filtered	-	9/25/1984	-	-	x	-	-	x	-	-	-	-
Pajarito at Rio Grande	WS	8409WSSGRP	Unfiltered	-	9/25/1984	-	-	x	-	-	x	-	x	-	-
Pajarito at Rio Grande	WS	8509WSSGRP	Filtered	-	9/24/1985	-	-	x	-	-	x	-	-	-	-
Pajarito at Rio Grande	WS	8509WSSGRP	Unfiltered	-	9/24/1985	-	-	x	-	-	x	-	x	-	-
Pajarito at Rio Grande	WS	8610WSSGRP	Filtered	-	10/28/1986	-	-	x	-	-	x	-	-	-	-
Pajarito at Rio Grande	WS	8610WSSGRP	Unfiltered	-	10/28/1986	-	-	x	-	-	x	-	x	-	-
Pajarito at Rio Grande	WS	8710WSSGRP	Filtered	-	10/6/1987	-	-	x	-	-	x	-	-	-	-
Pajarito at Rio Grande	WS	8710WSSGRP	Unfiltered	-	10/6/1987	-	-	x	-	-	x	-	x	-	-
Pajarito at Rio Grande	WS	8801WSSGRP	Filtered	-	1/1/1988	-	-	x	-	-	x	-	-	-	-
Pajarito at Rio Grande	WS	8801WSSGRP	Unfiltered	-	1/1/1988	-	-	x	-	-	x	-	x	-	-
Pajarito at Rio Grande	WS	8910WSSGRP	Filtered	-	10/6/1989	-	-	x	-	-	x	-	-	-	-
Pajarito at Rio Grande	WS	8910WSSGRP	Unfiltered	-	10/6/1989	-	-	x	-	-	x	-	x	-	-
Pajarito at Rio Grande	WS	9010WSSGRP	Filtered	-	10/1/1990	-	-	x	-	-	x	-	-	-	-

Table C-2.0-2 (continued)

Location ID	Media Description	Sample ID	Field Prep	Field QC Type	Collection Date	DIOX/FUR	DRO	GENINORG	HERB	HEXP	Metals	PEST/PCB	RAD	SVOA	VOA
Pajarito at Rio Grande	WS	9010WSSGRP	Unfiltered	-	10/1/1990	-	-	x	-	-	x	-	x	-	-
Pajarito at Rio Grande	WS	9101WSSGRP	Filtered	-	1/1/1991	-	-	x	-	-	x	-	-	-	-
Pajarito at Rio Grande	WS	9101WSSGRP	Unfiltered	-	1/1/1991	-	-	x	-	-	x	-	x	-	-
Pajarito at Rio Grande	WS	9209WSSGRP	Filtered	-	9/9/1992	-	-	x	-	-	x	-	-	-	-
Pajarito at Rio Grande	WS	9209WSSGRP	Unfiltered	-	9/9/1992	-	-	x	-	-	x	-	x	-	-
Pajarito at Rio Grande	WS	9310WSSGRP	Filtered	-	10/13/1993	-	-	x	-	-	x	-	-	-	-
Pajarito at Rio Grande	WS	9310WSSGRP	Unfiltered	-	10/13/1993	-	-	-	-	-	x	-	x	-	-
Pajarito at Rio Grande	WS	9409WSSGRP	Filtered	-	9/30/1994	-	-	x	-	-	x	-	-	-	-
Pajarito at Rio Grande	WS	9409WSSGRP	Unfiltered	-	9/30/1994	-	-	-	-	-	x	-	x	-	-
Pajarito at Rio Grande	WS	MNM95090117	Filtered	-	9/11/1995	-	-	x	-	-	-	-	-	-	-
Pajarito at Rio Grande	WS	MNM95090117	Unfiltered	-	9/11/1995	-	-	x	-	x	x	x	x	x	x
Pajarito at Rio Grande	WS	MM96101WGRP	Filtered	-	10/7/1996	-	-	x	-	-	-	-	-	-	-
Pajarito at Rio Grande	WS	MM96101WGRP	Unfiltered	-	10/7/1996	-	-	x	-	x	x	x	x	x	x
Pajarito at Rio Grande	WS	MM97091WGRP	Filtered	-	9/29/1997	-	-	x	-	-	x	-	-	-	-
Pajarito at Rio Grande	WS	MM97091WGRP	Unfiltered	-	9/29/1997	-	-	x	-	-	x	-	x	x	x
Pajarito at Rio Grande	WS	MM98091WGRP	Filtered	-	9/28/1998	-	-	x	-	-	x	-	-	-	-
Pajarito at Rio Grande	WS	MM98091WGRP	Unfiltered	-	9/28/1998	-	-	x	-	x	x	x	x	x	-

Table C-2.0-2 (continued)

Location ID	Media Description	Sample ID	Field Prep	Field QC Type	Collection Date	DIOX/FUR	DRO	GENINORG	HERB	HEXP	Metals	PEST/PCB	RAD	SVOA	VOA
Pajarito at Rio Grande	WS	MM98092WGRP	Filtered	-	9/29/1998	-	-	x	-	-	x	-	-	-	-
Pajarito at Rio Grande	WS	MM98092WGRP	Unfiltered	-	9/29/1998	-	-	x	-	x	x	x	x	x	-
Pajarito at Rio Grande	WS	CM99091WGRP	Filtered	-	9/21/1999	-	-	x	-	-	x	-	-	-	-
Pajarito at Rio Grande	WS	CM99091WGRP	Unfiltered	-	9/21/1999	-	-	x	-	-	x	x	x	x	x
Pajarito at Rio Grande	WS	GC00091WGRP	Filtered	-	9/26/2000	-	-	x	-	-	x	-	-	-	-
Pajarito at Rio Grande	WS	GC00091WGRP	Unfiltered	-	9/26/2000	-	-	x	-	x	x	x	x	x	x
Pajarito at Rio Grande	WS	GF01091WGRP	Filtered	-	9/25/2001	-	-	x	-	-	x	-	-	-	-
Pajarito at Rio Grande	WS	GU01091WGRP	Unfiltered	-	9/25/2001	-	-	x	-	x	x	x	x	x	x
Pajarito at Rio Grande	WS	GF02100WGRP01	Filtered	-	10/17/2002	-	-	x	-	-	x	-	-	-	-
Pajarito at Rio Grande	WS	GU02100WGRP01	Unfiltered	-	10/17/2002	-	-	x	-	x	x	x	x	x	x
Pajarito at Rio Grande	WS	GF03080WGRP01	Filtered	-	10/7/2003	-	-	x	-	-	x	-	-	-	-
Pajarito at Rio Grande	WS	GU03080WGRP01	Unfiltered	-	10/7/2003	-	-	x	-	x	x	x	x	x	x
Pajarito at Rio Grande	WS	GF04090WGRP01	Filtered	-	9/13/2004	-	-	x	-	-	x	-	-	-	-
Pajarito at Rio Grande	WS	GU04090WGRP01	Unfiltered	-	9/13/2004	-	-	x	-	-	x	-	x	-	-
Pajarito at Rio Grande	WS	GU04090WGRP02	Unfiltered	-	9/14/2004	-	-	-	-	x	-	x	-	x	x
Pajarito at Rio Grande	WS	GU05090PGRP02	Unfiltered	-	9/26/2005	-	-	-	-	x	-	x	-	x	x
Pajarito at Rio Grande	WS	GF05090PGRP01	Filtered	-	9/26/2005	-	-	x	-	-	x	-	x	-	-

Table C-2.0-2 (continued)

Location ID	Media Description	Sample ID	Field Prep	Field QC Type	Collection Date	DIOX/FUR	DRO	GENINORG	HERB	HEXP	Metals	PEST/PCB	RAD	SVOA	VOA
Pajarito at Rio Grande	WS	GU05090PGRP01	Unfiltered	-	9/26/2005	-	-	x	-	-	x	-	x	-	-
Pajarito at SR-4	WT	7908WTS4SP	Filtered	-	8/14/1979	-	-	x	-	-	x	-	x	-	-
Pajarito at SR-4	WT	8301WTS4SP	Filtered	-	1/1/1983	-	-	x	-	-	x	-	x	-	-
Pajarito at SR-4	WT	8301WTS4SP	Unfiltered	-	1/1/1983	-	-	-	-	-	-	-	x	-	-
Pajarito at SR-4	WT	WT8510112341	Filtered	-	10/11/1985	-	-	-	-	-	x	-	x	-	-
Pajarito at SR-4	WT	WT8510162341	Filtered	-	10/16/1985	-	-	-	-	-	x	-	x	-	-
Pajarito at SR-4	WT	WT8606262341	Filtered	-	6/26/1986	-	-	-	-	-	x	-	x	-	-
Pajarito at SR-4	WT	WT8606262341	Unfiltered	-	6/26/1986	-	-	-	-	-	-	-	x	-	-
Pajarito at SR-4	WT	WT8606302341	Filtered	-	6/30/1986	-	-	-	-	-	x	-	x	-	-
Pajarito at SR-4	WT	WT8606302341	Unfiltered	-	6/30/1986	-	-	-	-	-	-	-	x	-	-
Pajarito at SR-4	WT	WT8607022341	Filtered	-	7/2/1986	-	-	-	-	-	x	-	x	-	-
Pajarito at SR-4	WT	WT8607022341	Unfiltered	-	7/2/1986	-	-	-	-	-	-	-	x	-	-
Pajarito at SR-4	WT	WT8607072341	Filtered	-	7/7/1986	-	-	-	-	-	x	-	x	-	-
Pajarito at SR-4	WT	WT8607072341	Unfiltered	-	7/7/1986	-	-	-	-	-	-	-	x	-	-
Pajarito at SR-4	WT	WT8607102341	Filtered	-	7/10/1986	-	-	-	-	-	x	-	x	-	-
Pajarito at SR-4	WT	WT8607102341	Unfiltered	-	7/10/1986	-	-	-	-	-	-	-	x	-	-
Pajarito at SR-4	WT	WT8607142341	Filtered	-	7/14/1986	-	-	-	-	-	x	-	x	-	-

Table C-2.0-2 (continued)

Location ID	Media Description	Sample ID	Field Prep	Field QC Type	Collection Date	DIOX/FUR	DRO	GENINORG	HERB	HEXP	Metals	PEST/PCB	RAD	SVOA	VOA
Pajarito at SR-4	WT	WT8607142341	Unfiltered	-	7/14/1986	-	-	-	-	-	-	-	x	-	-
Pajarito at SR-4	WT	WT8607162341	Filtered	-	7/16/1986	-	-	-	-	-	x	-	x	-	-
Pajarito at SR-4	WT	WT8607162341	Unfiltered	-	7/16/1986	-	-	-	-	-	-	-	x	-	-
Pajarito at SR-4	WT	WT8607212341	Filtered	-	7/21/1986	-	-	-	-	-	x	-	x	-	-
Pajarito at SR-4	WT	WT8607212341	Unfiltered	-	7/21/1986	-	-	-	-	-	-	-	x	-	-
Pajarito at SR-4	WT	WT8703022341	Filtered	-	3/2/1987	-	-	-	-	-	-	-	x	-	-
Pajarito at SR-4	WT	WT8703022341	Unfiltered	-	3/2/1987	-	-	-	-	-	-	-	x	-	-
Pajarito at SR-4	WT	WT8703052341	Filtered	-	3/5/1987	-	-	-	-	-	-	-	x	-	-
Pajarito at SR-4	WT	WT8703052341	Unfiltered	-	3/5/1987	-	-	-	-	-	-	-	x	-	-
Pajarito at SR-4	WT	WT8703062341	Filtered	-	3/6/1987	-	-	-	-	-	-	-	x	-	-
Pajarito at SR-4	WT	WT8703062341	Unfiltered	-	3/6/1987	-	-	-	-	-	-	-	x	-	-
Pajarito at SR-4	WT	WT8703232341	Filtered	-	3/23/1987	-	-	-	-	-	-	-	x	-	-
Pajarito at SR-4	WT	WT8703232341	Unfiltered	-	3/23/1987	-	-	-	-	-	-	-	x	-	-
Pajarito at SR-4	WT	WT8703302341	Filtered	-	3/30/1987	-	-	-	-	-	-	-	x	-	-
Pajarito at SR-4	WT	WT8703302341	Unfiltered	-	3/30/1987	-	-	-	-	-	-	-	x	-	-
Pajarito at SR-4	WT	WT8704062341	Filtered	-	4/6/1987	-	-	-	-	-	-	-	x	-	-
Pajarito at SR-4	WT	WT8704062341	Unfiltered	-	4/6/1987	-	-	-	-	-	-	-	x	-	-

Table C-2.0-2 (continued)

Location ID	Media Description	Sample ID	Field Prep	Field QC Type	Collection Date	DIOX/FUR	DRO	GENINORG	HERB	HEXP	Metals	PEST/PCB	RAD	SVOA	VOA
Pajarito at SR-4	WT	WT8704202341	Filtered	-	4/20/1987	-	-	-	-	-	-	-	x	-	-
Pajarito at SR-4	WT	WT8704202341	Unfiltered	-	4/20/1987	-	-	-	-	-	-	-	x	-	-
Pajarito at SR-4	WT	WT8704302341	Filtered	-	4/30/1987	-	-	-	-	-	-	-	x	-	-
Pajarito at SR-4	WT	WT8704302341	Unfiltered	-	4/30/1987	-	-	-	-	-	-	-	x	-	-
Pajarito at SR-4	WT	WT8705042341	Filtered	-	5/4/1987	-	-	-	-	-	-	-	x	-	-
Pajarito at SR-4	WT	WT8705042341	Unfiltered	-	5/4/1987	-	-	-	-	-	-	-	x	-	-
Pajarito at SR-4	WT	WT8705112341	Filtered	-	5/11/1987	-	-	-	-	-	-	-	x	-	-
Pajarito at SR-4	WT	WT8705112341	Unfiltered	-	5/11/1987	-	-	-	-	-	-	-	x	-	-
Pajarito at SR-4	WT	WT8705182341	Filtered	-	5/18/1987	-	-	-	-	-	-	-	x	-	-
Pajarito at SR-4	WT	WT8705182341	Unfiltered	-	5/18/1987	-	-	-	-	-	-	-	x	-	-
Pajarito at SR-4	WT	WT8705262341	Filtered	-	5/26/1987	-	-	-	-	-	-	-	x	-	-
Pajarito at SR-4	WT	WT8705262341	Unfiltered	-	5/26/1987	-	-	-	-	-	-	-	x	-	-
Pajarito at SR-4	WT	WT8706042341	Filtered	-	6/4/1987	-	-	-	-	-	-	-	x	-	-
Pajarito at SR-4	WT	WT8706042341	Unfiltered	-	6/4/1987	-	-	-	-	-	-	-	x	-	-
Pajarito at SR-4	WT	WT8706082341	Filtered	-	6/8/1987	-	-	-	-	-	-	-	x	-	-
Pajarito at SR-4	WT	WT8706082341	Unfiltered	-	6/8/1987	-	-	-	-	-	-	-	x	-	-
Pajarito at SR-4	WT	9301WTS4SP	Filtered	-	1/1/1993	-	-	-	-	-	-	-	x	-	-

Table C-2.0-2 (continued)

Location ID	Media Description	Sample ID	Field Prep	Field QC Type	Collection Date	DIOX/FUR	DRO	GENINORG	HERB	HEXP	Metals	PEST/PCB	RAD	SVOA	VOA
Pajarito at SR-4	WT	9303WTS4SP	Filtered	-	3/25/1993	-	-	-	-	-	-	-	x	-	-
Pajarito at SR-4	WT	WT9304072341	Filtered	-	4/7/1993	-	-	-	-	-	-	-	x	-	-
Pajarito at SR-4	WT	WT9304192341	Filtered	-	4/19/1993	-	-	-	-	-	-	-	x	-	-
Pajarito at SR-4	WT	WT9304192341	Unfiltered	-	4/19/1993	-	-	-	-	-	-	-	x	-	-
Pajarito at SR-4	WT	WT9304192341	Unfiltered	-	4/19/1993	-	-	x	-	-	-	-	x	-	-
Pajarito at SR-4	WT	9305WTS4SP	Filtered	-	5/4/1993	-	-	-	-	-	-	-	x	-	-
Pajarito at SR-4	WT	MNM95070041	Filtered	-	7/18/1995	-	-	-	-	-	x	-	x	-	-
Pajarito at SR-501	WT	8704WT3951	Filtered	-	4/29/1987	-	-	-	-	-	x	-	x	-	-
Pajarito at SR-501	WT	8704WT3951	Unfiltered	-	4/29/1987	-	-	-	-	-	-	-	x	-	-
Pajarito at SR-501	WT	MNM95050102	Filtered	-	5/25/1995	-	-	-	-	-	-	-	x	-	-
Pajarito below confluences of South and North Anchor East Basin	WP	GF06080PPBFB01	Filtered	-	8/24/2006	-	-	x	-	-	x	-	x	-	-
Pajarito below confluences of South and North Anchor East Basin	WP	GF06080PPBFB90	Filtered	Field Duplicate	8/24/2006	-	-	x	-	-	x	-	x	-	-
Pajarito below confluences of South and North Anchor East Basin	WP	GU06080PPBFB01	Filtered	-	8/24/2006	-	-	x	-	-	-	-	-	-	-

Table C-2.0-2 (continued)

Location ID	Media Description	Sample ID	Field Prep	Field QC Type	Collection Date	DIOX/FUR	DRO	GENINORG	HERB	HEXP	Metals	PEST/PCB	RAD	SVOA	VOA
Pajarito below confluences of South and North Anchor East Basin	WP	GU06080PPBFB01	Unfiltered	-	8/24/2006	-	-	x	x	-	x	x	x	x	x
Pajarito below confluences of South and North Anchor East Basin	WP	GU06080PPBFB90	Filtered	Field Duplicate	8/24/2006	-	-	x	-	-	-	-	-	-	-
Pajarito below confluences of South and North Anchor East Basin	WP	GU06080PPBFB90	Unfiltered	Field Duplicate	8/24/2006	-	-	x	x	-	x	x	x	x	x
Pajarito below confluences of South and North Anchor East Basin	WP	SU06080PPBFB01	Unfiltered	-	8/24/2006	-	-	-	-	x	-	-	-	-	-
Pajarito below confluences of South and North Anchor East Basin	WP	SU06080PPBFB90	Unfiltered	Field Duplicate	8/24/2006	-	-	-	-	x	-	-	-	-	-
Pajarito below confluences of South and North Anchor East Basin	WP	UU06080PPBFB01	Unfiltered	-	8/24/2006	-	-	-	-	-	-	-	x	-	-
Pajarito below confluences of South and North Anchor East Basin	WP	UU06080PPBFB90	Unfiltered	Field Duplicate	8/24/2006	-	-	-	-	-	-	-	x	-	-
Pajarito below confluences of South and North Anchor East Basin	WS	GF06110PPBF101	Filtered	-	12/8/2006	-	-	x	-	-	x	-	x	-	-

Table C-2.0-2 (continued)

Location ID	Media Description	Sample ID	Field Prep	Field QC Type	Collection Date	DIOX/FUR	DRO	GENINORG	HERB	HEXP	Metals	PEST/PCB	RAD	SVOA	VOA
Pajarito below confluences of South and North Anchor East Basin	WS	GU06110PPBF101	Filtered	-	12/8/2006	-	-	x	-	-	-	-	-	-	-
Pajarito below confluences of South and North Anchor East Basin	WS	GU06110PPBF101	Unfiltered	-	12/8/2006	-	-	x	-	-	x	x	x	x	x
Pajarito below confluences of South and North Anchor East Basin	WS	SU06110PPBF101	Unfiltered	-	12/8/2006	-	-	-	-	x	-	-	-	-	-
Pajarito below confluences of South and North Anchor East Basin	WS	UU06110PPBF101	Unfiltered	-	12/8/2006	-	-	-	-	-	-	-	x	-	-
Pajarito below confluences of South and North Anchor East Basin	WS	GF07030PPBF101	Filtered	-	3/20/2007	-	-	x	-	-	x	-	x	-	-
Pajarito below confluences of South and North Anchor East Basin	WS	GU07030PPBF101	Unfiltered	-	3/20/2007	-	-	x	-	x	x	x	x	x	x
Pajarito below confluences of South and North Anchor East Basin	WS	SU07030PPBF101	Unfiltered	-	3/20/2007	-	-	-	-	x	-	-	-	-	-
Pajarito below confluences of South and North Anchor East Basin	WP	UU07030PPBF101	Unfiltered	-	3/20/2007	-	-	-	-	-	-	-	x	-	-

Table C-2.0-2 (continued)

Location ID	Media Description	Sample ID	Field Prep	Field QC Type	Collection Date	DIOX/FUR	DRO	GENINORG	HERB	HEXP	Metals	PEST/PCB	RAD	SVOA	VOA
Pajarito below confluences of South and North Anchor East Basin	WS	GF07060PPBF101	Filtered	-	6/28/2007	-	-	x	-	-	x	-	x	-	-
Pajarito below confluences of South and North Anchor East Basin	WS	GU07060PPBF101	Unfiltered	-	6/28/2007	-	-	x	-	x	x	x	x	x	x
Pajarito below confluences of South and North Anchor East Basin	WS	SU07060PPBF101	Unfiltered	-	6/28/2007	-	-	-	-	x	-	-	-	-	-
Pajarito below confluences of South and North Anchor East Basin	WS	UU07060PPBF101	Unfiltered	-	6/28/2007	-	-	-	-	-	-	-	x	-	-
Pajarito below confluences of South and North Anchor East Basin	WS	GF07090PPBF101	Filtered	-	9/4/2007	-	-	x	-	-	x	-	x	-	-
Pajarito below confluences of South and North Anchor East Basin	WS	GU07090PPBF101	Unfiltered	-	9/4/2007	-	-	x	x	x	x	x	x	x	x
Pajarito below confluences of South and North Anchor East Basin	WS	SU07090PPBF101	Unfiltered	-	9/4/2007	-	-	-	-	x	-	-	-	-	-
Pajarito below confluences of South and North Anchor East Basin	WS	UU07090PPBF101	Unfiltered	-	9/4/2007	-	-	-	-	-	-	-	x	-	-

Table C-2.0-2 (continued)

Location ID	Media Description	Sample ID	Field Prep	Field QC Type	Collection Date	DIOX/FUR	DRO	GENINORG	HERB	HEXP	Metals	PEST/PCB	RAD	SVOA	VOA
Pajarito below confluences of South and North Anchor East Basin	WS	CAPA-08-9227	Filtered	-	12/3/2007	-	-	x	-	-	x	-	x	-	-
Pajarito below confluences of South and North Anchor East Basin	WS	CAPA-08-9228	Unfiltered	-	12/3/2007	-	-	x	-	x	x	x	x	x	x
Pajarito below confluences of South and North Anchor East Basin	WS	CAPA-08-13032	Filtered	-	6/10/2008	-	-	x	-	-	x	-	x	-	-
Pajarito below confluences of South and North Anchor East Basin	WS	CAPA-08-13033	Unfiltered	-	6/10/2008	-	-	x	-	x	x	x	x	x	x
Pajarito below SR-501	WT	PF00063E240	Filtered	-	6/28/2000	-	-	x	-	-	x	-	x	-	-
Pajarito below SR-501	WT	PS00063E240	Unfiltered	-	6/28/2000	x	-	x	-	x	x	x	x	x	-
Pajarito below SR-501	WT	PS00064E240	Unfiltered	Field Duplicate	6/28/2000	-	-	x	-	-	-	-	-	-	-
Pajarito below SR-501	WT	GF00091E240	Filtered	-	9/8/2000	-	-	x	-	-	x	-	x	-	-
Pajarito below SR-501	WT	GS00091E240	Filtered	-	9/8/2000	-	-	x	-	-	-	-	-	-	-
Pajarito below SR-501	WT	GS00091E240	Unfiltered	-	9/8/2000	x	-	x	-	x	x	x	x	x	x
Pajarito below SR-501	WT	GS00092E240	Unfiltered	Field Duplicate	9/8/2000	-	-	x	-	-	-	-	-	-	-

Table C-2.0-2 (continued)

Location ID	Media Description	Sample ID	Field Prep	Field QC Type	Collection Date	DIOX/FUR	DRO	GENINORG	HERB	HEXP	Metals	PEST/PCB	RAD	SVOA	VOA
Pajarito below SR-501	WT	GF00101E240	Filtered	-	10/23/2000	-	-	x	-	-	x	-	x	-	-
Pajarito below SR-501	WT	GS00101E240	Filtered	-	10/23/2000	-	-	x	-	-	-	-	-	-	-
Pajarito below SR-501	WT	GS00101E240	Unfiltered	-	10/23/2000	-	-	x	-	-	x	-	x	-	-
Pajarito below SR-501	WT	GS00102E240	Unfiltered	-	10/23/2000	-	-	x	-	-	-	-	-	-	-
Pajarito below SR-501	WT	GS00103E240	Unfiltered	-	10/23/2000	x	-	x	-	x	-	x	-	x	x
Pajarito below SR-501	WM	GF01031E240	Filtered	-	3/20/2001	-	-	x	-	-	x	-	x	-	-
Pajarito below SR-501	WM	GU01031E240	Unfiltered	-	3/20/2001	x	-	x	-	x	x	x	x	x	x
Pajarito below SR-501	WM	GF01041E240	Filtered	-	4/4/2001	-	-	x	-	-	x	-	x	-	-
Pajarito below SR-501	WM	GU01041E240	Unfiltered	-	4/4/2001	x	-	x	-	x	x	x	x	x	x
Pajarito below SR-501	WM	GF01042E0240	Filtered	-	4/18/2001	-	-	x	-	-	x	-	x	-	-
Pajarito below SR-501	WM	GU01042E240	Unfiltered	-	4/18/2001	x	-	x	-	x	x	x	x	x	x
Pajarito below SR-501	WM	GF01051E240	Filtered	-	5/2/2001	-	-	x	-	-	x	-	x	-	-
Pajarito below SR-501	WM	GU01051E240	Unfiltered	-	5/2/2001	x	-	x	-	x	x	x	x	x	x
Pajarito below SR-501	WT	GU01071E240	Unfiltered	-	7/26/2001	-	-	x	-	-	-	-	x	-	-
Pajarito below SR-501	WT	GU01071E240TSSM	Unfiltered	-	7/26/2001	-	-	x	-	-	-	-	-	-	-
Pajarito below SR-501	WT	GF01082E240	Filtered	-	8/9/2001	-	-	x	-	-	x	-	-	-	-
Pajarito below SR-501	WT	GU01082E240	Unfiltered	-	8/9/2001	-	-	x	-	-	x	-	-	-	-

Table C-2.0-2 (continued)

Location ID	Media Description	Sample ID	Field Prep	Field QC Type	Collection Date	DIOX/FUR	DRO	GENINORG	HERB	HEXP	Metals	PEST/PCB	RAD	SVOA	VOA
Pajarito below SR-501	WT	GU01082E240TSSM	Unfiltered	-	8/9/2001	-	-	x	-	-	-	-	-	-	-
Pajarito below SR-501	WT	GU03080E24001	Unfiltered	-	8/11/2003	-	-	x	-	-	-	-	-	-	-
Pajarito below SR-501	WM	GF05030M24001	Filtered	-	3/23/2005	-	-	x	-	-	-	-	-	-	-
Pajarito below SR-501	WM	GU05030M24001	Unfiltered	-	3/23/2005	-	-	x	-	-	x	-	x	-	-
Pajarito below SR-501	WT	GF05080E24001	Filtered	-	8/11/2005	-	-	x	-	-	x	-	-	-	-
Pajarito below SR-501	WT	GU05080E24001	Unfiltered	-	8/11/2005	-	-	x	-	-	x	-	x	-	-
Pajarito below SR-501	WT	GF05080E24002	Filtered	-	8/12/2005	-	-	x	-	-	x	-	-	-	-
Pajarito below SR-501	WT	GU05080E24002	Unfiltered	-	8/12/2005	-	-	x	-	-	x	-	-	-	-
Pajarito below SR-501	WT	GF05080E24003	Filtered	-	8/24/2005	-	-	x	-	-	-	-	-	-	-
Pajarito below SR-501	WT	GU05080E24003	Unfiltered	-	8/24/2005	-	-	x	-	-	-	-	x	-	-
Pajarito below SR-501	WT	GF060800E24001	Filtered	-	8/8/2006	-	-	x	-	-	x	-	-	-	-
Pajarito below SR-501	WT	GU060800E24001	Unfiltered	-	8/8/2006	-	-	x	-	-	x	-	x	-	-
Pajarito below SR-501	WT	GF060900E24001	Filtered	-	9/11/2006	-	-	x	-	-	x	-	-	-	-
Pajarito below SR-501	WT	GU060900E24001	Unfiltered	-	9/11/2006	-	-	x	-	-	x	-	x	-	-
Pajarito below SR-501	WM	GU070300M24001	Unfiltered	-	3/19/2007	-	-	x	-	-	-	-	-	-	-
Pajarito below SR-501	WT	GF070300E24001	Filtered	-	3/23/2007	-	-	x	-	-	x	-	-	-	-
Pajarito below SR-501	WT	GU070300E24001	Unfiltered	-	3/23/2007	-	-	x	-	-	x	-	x	-	-

Table C-2.0-2 (continued)

Location ID	Media Description	Sample ID	Field Prep	Field QC Type	Collection Date	DIOX/FUR	DRO	GENINORG	HERB	HEXP	Metals	PEST/PCB	RAD	SVOA	VOA
Pajarito below SR-501	WT	GF070700E24001	Filtered	-	7/14/2007	-	-	x	-	-	x	-	-	-	-
Pajarito below SR-501	WT	GU070700E24001	Unfiltered	-	7/14/2007	-	-	x	-	-	x	-	-	-	-
Pajarito below SR-501	WT	GF070700E24002	Filtered	-	7/26/2007	-	-	x	-	-	x	-	-	-	-
Pajarito below SR-501	WT	GU070700E24002	Unfiltered	-	7/26/2007	-	-	x	-	-	x	-	x	-	-
Pajarito below SR-501	WT	GF070800E24001	Filtered	-	7/30/2007	-	-	x	-	-	x	-	-	-	-
Pajarito below SR-501	WT	GU070800E24001	Unfiltered	-	7/30/2007	-	-	x	-	-	x	-	x	-	-
Pajarito below SR-501	WT	GU070800E24002	Unfiltered	-	8/29/2007	-	-	x	-	-	x	-	-	-	-
Pajarito below SR-501	WT	GU070900E24001	Unfiltered	-	9/2/2007	-	-	x	-	-	-	-	x	-	-
Pajarito below TA-18	WS	GF05060PBF501	Filtered	-	6/13/2005	-	-	x	-	-	x	-	-	-	-
Pajarito below TA-18	WS	GU05060PBF501	Unfiltered	-	6/13/2005	-	-	x	-	x	x	-	-	x	x
Pajarito Canyon	WS	WS6210257871	Filtered	-	10/25/1962	-	-	x	-	-	-	-	-	-	-
Pajarito Canyon	WS	WS6210257871	Unfiltered	-	10/25/1962	-	-	x	-	-	x	-	x	-	-
Pajarito Canyon	WS	WS6705097481	Filtered	-	5/9/1967	-	-	x	-	-	-	-	-	-	-
Pajarito Canyon	WS	WS6705097481	Unfiltered	-	5/9/1967	-	-	x	-	-	x	-	x	-	-
Pajarito Canyon	WS	6909WSPAJF	Unfiltered	-	9/17/1969	-	-	-	-	-	x	-	x	-	-
Pajarito Canyon	WS	WS7105027481	Unfiltered	-	5/2/1971	-	-	-	-	-	-	-	x	-	-
Pajarito Canyon	WS	7105WSWCJP	Unfiltered	-	5/7/1971	-	-	-	-	-	x	-	x	-	-

Table C-2.0-2 (continued)

Location ID	Media Description	Sample ID	Field Prep	Field QC Type	Collection Date	DIOX/FUR	DRO	GENINORG	HERB	HEXP	Metals	PEST/PCB	RAD	SVOA	VOA
Pajarito Canyon	WS	WS7105077481	Unfiltered	-	5/7/1971	-	-	-	-	-	-	-	x	-	-
Pajarito Canyon	WS	7306WSWCJP	Unfiltered	-	6/19/1973	-	-	-	-	-	x	-	x	-	-
Pajarito Canyon	WS	7401WSWCJP	Unfiltered	-	1/1/1974	-	-	-	-	-	-	-	x	-	-
Pajarito Canyon	WS	7407WSWCJP	Unfiltered	-	7/29/1974	-	-	x	-	-	x	-	-	-	-
Pajarito Canyon	WS	7410WSWCJP	Unfiltered	-	10/17/1974	-	-	x	-	-	-	-	-	-	-
Pajarito Canyon	WS	7503WSWCJP	Filtered	-	3/7/1975	-	-	x	-	-	-	-	-	-	-
Pajarito Canyon	WS	7503WSWCJP	Unfiltered	-	3/7/1975	-	-	x	-	-	-	-	x	-	-
Pajarito Canyon	WS	7506WSWCJP	Unfiltered	-	6/11/1975	-	-	-	-	-	x	-	x	-	-
Pajarito Canyon	WS	7509WSWCJP	Filtered	-	9/15/1975	-	-	x	-	-	-	-	-	-	-
Pajarito Canyon	WS	7509WSWCJP	Unfiltered	-	9/15/1975	-	-	x	-	-	x	-	x	-	-
Pajarito Canyon	WS	7603WSWCJP	Filtered	-	3/31/1976	-	-	x	-	-	-	-	-	-	-
Pajarito Canyon	WS	7603WSWCJP	Unfiltered	-	3/31/1976	-	-	x	-	-	x	-	x	-	-
Pajarito Canyon	WS	7610WSWCJP	Filtered	-	10/14/1976	-	-	x	-	-	-	-	-	-	-
Pajarito Canyon	WS	7610WSWCJP	Unfiltered	-	10/14/1976	-	-	x	-	-	x	-	x	-	-
Pajarito Canyon	WS	7703WSWCJP	Filtered	-	3/17/1977	-	-	x	-	-	-	-	-	-	-
Pajarito Canyon	WS	7703WSWCJP	Unfiltered	-	3/17/1977	-	-	x	-	-	-	-	-	-	-
Pajarito Canyon	WS	7710WSWCJP	Filtered	-	10/25/1977	-	-	x	-	-	-	-	-	-	-

Table C-2.0-2 (continued)

Location ID	Media Description	Sample ID	Field Prep	Field QC Type	Collection Date	DIOX/FUR	DRO	GENINORG	HERB	HEXP	Metals	PEST/PCB	RAD	SVOA	VOA
Pajarito Canyon	WS	7710WSWCJP	Unfiltered	-	10/25/1977	-	-	x	-	-	-	-	-	-	-
Pajarito Canyon	WS	7803WSWCJP	Filtered	-	3/13/1978	-	-	x	-	-	x	-	-	-	-
Pajarito Canyon	WS	7803WSWCJP	Unfiltered	-	3/13/1978	-	-	x	-	-	x	-	x	-	-
Pajarito Canyon	WS	7903WSWCJP	Filtered	-	3/13/1979	-	-	x	-	-	x	-	-	-	-
Pajarito Canyon	WS	7903WSWCJP	Unfiltered	-	3/13/1979	-	-	x	-	-	x	-	x	-	-
Pajarito Canyon	WS	7909WSWCJP	Unfiltered	-	9/18/1979	-	-	-	-	-	x	-	x	-	-
Pajarito Canyon	WS	8003WSWCJP	Filtered	-	3/4/1980	-	-	x	-	-	x	-	-	-	-
Pajarito Canyon	WS	8003WSWCJP	Unfiltered	-	3/4/1980	-	-	x	-	-	x	-	x	-	-
Pajarito Canyon	WS	8101WSWCJP	Filtered	-	1/1/1981	-	-	x	-	-	x	-	-	-	-
Pajarito Canyon	WS	8101WSWCJP	Unfiltered	-	1/1/1981	-	-	x	-	-	-	-	-	-	-
Pajarito Canyon	WS	8103WSWCJP	Unfiltered	-	3/26/1981	-	-	-	-	-	x	-	x	-	-
Pajarito Canyon	WS	8204WSWCJP	Filtered	-	4/7/1982	-	-	x	-	-	-	-	-	-	-
Pajarito Canyon	WS	8204WSWCJP	Unfiltered	-	4/7/1982	-	-	-	-	-	x	-	x	-	-
Pajarito Canyon	WS	8209WSWCJP	Unfiltered	-	9/22/1982	-	-	-	-	-	x	-	x	-	-
Pajarito Canyon	WS	8303WSWCJP	Filtered	-	3/16/1983	-	-	x	-	-	x	-	-	-	-
Pajarito Canyon	WS	8303WSWCJP	Unfiltered	-	3/16/1983	-	-	x	-	-	x	-	x	-	-
Pajarito Canyon	WS	8310WSWCJP	Unfiltered	-	10/11/1983	-	-	-	-	-	x	-	x	-	-

Table C-2.0-2 (continued)

Location ID	Media Description	Sample ID	Field Prep	Field QC Type	Collection Date	DIOX/FUR	DRO	GENINORG	HERB	HEXP	Metals	PEST/PCB	RAD	SVOA	VOA
Pajarito Canyon	WT	8401WTWCJP	Filtered	-	1/1/1984	-	-	-	-	-	-	-	x	-	-
Pajarito Canyon	WT	8401WTWCJP	Unfiltered	-	1/1/1984	-	-	-	-	-	-	-	x	-	-
Pajarito Canyon	WS	8403WSWCJP	Filtered	-	3/15/1984	-	-	x	-	-	x	-	-	-	-
Pajarito Canyon	WS	8403WSWCJP	Unfiltered	-	3/15/1984	-	-	x	-	-	x	-	x	-	-
Pajarito Canyon	WS	8503WSWCJP	Filtered	-	3/25/1985	-	-	x	-	-	x	-	-	-	-
Pajarito Canyon	WS	8503WSWCJP	Unfiltered	-	3/25/1985	-	-	x	-	-	x	-	x	-	-
Pajarito Canyon	WS	8509WSWCJP	Unfiltered	-	9/16/1985	-	-	-	-	-	x	-	x	-	-
Pajarito Canyon	WS	8602WSWCJP	Filtered	-	2/26/1986	-	-	x	-	-	x	-	-	-	-
Pajarito Canyon	WS	8602WSWCJP	Unfiltered	-	2/26/1986	-	-	x	-	-	x	-	x	-	-
Pajarito Canyon	WS	8609WSWCJP	Unfiltered	-	9/4/1986	-	-	-	-	-	x	-	x	-	-
Pajarito Canyon	WS	8703WSWCJP	Filtered	-	3/3/1987	-	-	x	-	-	x	-	-	-	-
Pajarito Canyon	WS	8703WSWCJP	Unfiltered	-	3/3/1987	-	-	x	-	-	x	-	x	-	-
Pajarito Canyon	WS	8709WSWCJP	Unfiltered	-	9/22/1987	-	-	-	-	-	x	-	x	-	-
Pajarito Canyon	WS	8803WSWCJP	Filtered	-	3/31/1988	-	-	x	-	-	x	-	-	-	-
Pajarito Canyon	WS	8803WSWCJP	Unfiltered	-	3/31/1988	-	-	x	-	-	x	-	x	-	-
Pajarito Canyon	WS	8903WSWCJP	Filtered	-	3/16/1989	-	-	x	-	-	x	-	-	-	-
Pajarito Canyon	WS	8903WSWCJP	Unfiltered	-	3/16/1989	-	-	x	-	-	x	-	x	-	-

Table C-2.0-2 (continued)

Location ID	Media Description	Sample ID	Field Prep	Field QC Type	Collection Date	DIOX/FUR	DRO	GENINORG	HERB	HEXP	Metals	PEST/PCB	RAD	SVOA	VOA
Pajarito Canyon	WS	9004WSWCJP	Filtered	-	4/16/1990	-	-	x	-	-	x	-	-	-	-
Pajarito Canyon	WS	9004WSWCJP	Unfiltered	-	4/16/1990	-	-	x	-	-	x	-	x	-	-
Pajarito Canyon	WS	9105WSWCJP	Filtered	-	5/16/1991	-	-	x	-	-	x	-	-	-	-
Pajarito Canyon	WS	9105WSWCJP	Unfiltered	-	5/16/1991	-	-	x	-	-	x	-	x	-	-
Pajarito Canyon	WT	9201WTWCJP	Filtered	-	1/1/1992	-	-	-	-	-	x	-	x	-	-
Pajarito Canyon	WT	WT9204162351	Filtered	-	4/16/1992	-	-	-	-	-	-	-	x	-	-
Pajarito Canyon	WT	WT9204162351	Unfiltered	-	4/16/1992	-	-	-	-	-	-	-	x	-	-
Pajarito Canyon	WT	WT9204162351	Unfiltered	-	4/16/1992	-	-	x	-	-	-	-	x	-	-
Pajarito Canyon	WT	WT9204242351	Filtered	-	4/24/1992	-	-	-	-	-	-	-	x	-	-
Pajarito Canyon	WT	WT9204242351	Unfiltered	-	4/24/1992	-	-	x	-	-	-	-	x	-	-
Pajarito Canyon	WT	WT9204242351	Unfiltered	-	4/24/1992	-	-	-	-	-	-	-	x	-	-
Pajarito Canyon	WS	9208WSWCJP	Filtered	-	8/5/1992	-	-	x	-	-	x	-	-	-	-
Pajarito Canyon	WS	9208WSWCJP	Unfiltered	-	8/5/1992	-	-	x	-	-	x	-	x	-	-
Pajarito Canyon	WS	9301WSWCJP	Filtered	-	1/1/1993	-	-	x	-	-	x	-	-	-	-
Pajarito Canyon	WS	9301WSWCJP	Unfiltered	-	1/1/1993	-	-	x	-	-	x	-	x	-	-
Pajarito Canyon	WT	9301WTWCJP	Filtered	-	1/1/1993	-	-	-	-	-	-	-	x	-	-
Pajarito Canyon	WT	9303WTWCJP	Filtered	-	3/25/1993	-	-	-	-	-	-	-	x	-	-

Table C-2.0-2 (continued)

Location ID	Media Description	Sample ID	Field Prep	Field QC Type	Collection Date	DIOX/FUR	DRO	GENINORG	HERB	HEXP	Metals	PEST/PCB	RAD	SVOA	VOA
Pajarito Canyon	WT	WT9304072351	Filtered	-	4/7/1993	-	-	-	-	-	-	-	x	-	-
Pajarito Canyon	WT	WT9304192351	Filtered	-	4/19/1993	-	-	-	-	-	-	-	x	-	-
Pajarito Canyon	WT	WT9304192351	Unfiltered	-	4/19/1993	-	-	-	-	-	-	-	x	-	-
Pajarito Canyon	WT	WT9304192351	Unfiltered	-	4/19/1993	-	-	x	-	-	-	-	x	-	-
Pajarito Canyon	WT	9305WTWCJP	Filtered	-	5/4/1993	-	-	-	-	-	-	-	x	-	-
Pajarito Canyon	WS	9403WGWCJP	Filtered	-	3/21/1994	-	-	x	-	-	-	-	-	-	-
Pajarito Canyon	WS	9403WGWCJP	Unfiltered	-	3/21/1994	-	-	-	-	-	x	-	x	x	x
Pajarito Canyon	WT	9405WTWCJP	Filtered	-	5/20/1994	-	-	-	-	-	-	-	x	-	-
Pajarito Canyon	WT	9405WTWCJP	Unfiltered	-	5/20/1994	-	-	-	-	-	-	-	x	-	-
Pajarito Canyon	WS	9405WSWCJP	Unfiltered	-	5/25/1994	-	-	-	-	-	-	-	x	-	-
Pajarito Canyon	WS	9407WGWCJP	Filtered	-	7/22/1994	-	-	x	-	-	-	-	-	-	-
Pajarito Canyon	WS	9407WGWCJP	Unfiltered	-	7/22/1994	-	-	-	-	-	x	-	x	-	-
Pajarito Canyon	WS	WG9408092351	Filtered	-	8/9/1994	-	-	x	-	-	x	-	-	-	-
Pajarito Canyon	WS	WG9408232351	Filtered	-	8/23/1994	-	-	-	-	-	-	-	x	-	-
Pajarito Canyon	WS	9412WGWCJP	Unfiltered	-	12/9/1994	-	-	x	-	-	x	-	-	-	-
Pajarito Canyon	WS	9504WGWCJP	Filtered	-	4/28/1995	-	-	x	-	-	x	-	-	-	-
Pajarito Canyon	WS	9507WGWCJP	Filtered	-	7/7/1995	-	-	x	-	-	-	-	-	-	-

Table C-2.0-2 (continued)

Location ID	Media Description	Sample ID	Field Prep	Field QC Type	Collection Date	DIOX/FUR	DRO	GENINORG	HERB	HEXP	Metals	PEST/PCB	RAD	SVOA	VOA
Pajarito Canyon	WS	9507WGWCJP	Unfiltered	-	7/7/1995	-	-	-	-	-	-	-	-	-	x
Pajarito Canyon	WS	MNM95070059	Filtered	-	7/27/1995	-	-	x	-	-	-	-	-	-	-
Pajarito Canyon	WS	MNM95070059	Unfiltered	-	7/27/1995	-	-	x	-	x	x	x	x	x	x
Pajarito Canyon	WS	9508WGWCJP	Filtered	-	8/18/1995	-	-	x	-	-	-	-	x	-	-
Pajarito Canyon	WS	9508WGWCJP	Unfiltered	-	8/18/1995	-	-	-	-	x	-	-	-	-	-
Pajarito Canyon	WS	9510WGWCJP	Filtered	-	10/20/1995	-	-	x	-	-	-	-	-	-	-
Pajarito Canyon	WS	9602WGWCJP	Filtered	-	2/20/1996	-	-	x	-	-	x	-	-	-	-
Pajarito Canyon	WS	9602WGWCJP	Unfiltered	-	2/20/1996	-	-	-	-	-	-	-	x	-	-
Pajarito Canyon	WS	9603WGWCJP	Filtered	-	3/7/1996	-	-	x	-	-	-	-	-	-	-
Pajarito Canyon	WS	9604WGWCJP	Filtered	-	4/16/1996	-	-	x	-	-	-	-	x	-	-
Pajarito Canyon	WS	9607WGWCJP	Filtered	-	7/26/1996	-	-	x	-	-	x	-	x	-	-
Pajarito Canyon	WS	9612WGWCJP	Filtered	-	12/4/1996	-	-	x	-	-	-	-	x	-	-
Pajarito Canyon	WS	9612WGWCJP	Unfiltered	-	12/4/1996	-	-	x	-	x	x	-	-	-	-
Pajarito Canyon	WS	MM96121WCJP	Filtered	-	12/11/1996	-	-	x	-	-	-	-	-	-	-
Pajarito Canyon	WS	MM96121WCJP	Unfiltered	-	12/11/1996	-	-	x	-	x	x	x	x	x	x
Pajarito Canyon	WT	MM97031PAJF	Filtered	-	3/25/1997	-	-	x	-	-	x	-	x	-	-
Pajarito Canyon	WT	MM97031PAJU	Filtered	-	3/25/1997	-	-	x	-	-	-	-	-	-	-

Table C-2.0-2 (continued)

Location ID	Media Description	Sample ID	Field Prep	Field QC Type	Collection Date	DIOX/FUR	DRO	GENINORG	HERB	HEXP	Metals	PEST/PCB	RAD	SVOA	VOA
Pajarito Canyon	WT	MM97031PAJU	Unfiltered	-	3/25/1997	-	-	x	-	-	x	-	x	-	-
Pajarito Canyon	WS	9705WGWCJP	Filtered	-	5/5/1997	-	-	x	-	-	-	-	-	-	-
Pajarito Canyon	WS	9711WGWCJP	Filtered	-	11/13/1997	-	-	x	-	-	x	-	x	-	-
Pajarito Canyon	WS	9712WGWCJP	Filtered	-	12/15/1997	-	-	x	-	-	-	-	-	-	-
Pajarito Canyon	WS	MM98041WCJP	Filtered	-	4/8/1998	-	-	x	-	-	x	-	-	-	-
Pajarito Canyon	WS	MM98041WCJP	Unfiltered	-	4/8/1998	-	-	x	-	-	x	-	x	-	-
Pajarito Canyon	WS	GC00101WCJP	Filtered	-	10/24/2000	-	-	x	-	-	x	-	-	-	-
Pajarito Canyon	WS	GC00101WCJP	Unfiltered	-	10/24/2000	-	-	x	-	x	x	x	x	x	x
Pajarito Canyon	WM	GF01041WCJP	Filtered	-	4/4/2001	-	-	x	-	-	x	-	x	-	-
Pajarito Canyon	WM	GU01041WCJP	Unfiltered	-	4/4/2001	-	-	x	-	-	x	x	x	x	x
Pajarito Retention Pond	WT	GF00081EPRP	Filtered	-	8/24/2000	-	-	x	-	-	x	-	x	-	-
Pajarito Retention Pond	WT	GS00081EPRP	Filtered	-	8/24/2000	-	-	x	-	-	-	-	-	-	-
Pajarito Retention Pond	WT	GS00081EPRP	Unfiltered	-	8/24/2000	-	x	x	-	-	x	-	x	-	-
Pajarito SR-4 Culvert	WT	PF00065ES4C	Filtered	-	6/28/2000	-	-	x	-	-	x	-	x	-	-
Pajarito SR-4 Culvert	WT	PS00065ES4C	Unfiltered	-	6/28/2000	x	-	x	-	x	x	x	x	x	-
Pajarito SR-4 Culvert	WT	PS00066ES4C	Unfiltered	Field Duplicate	6/28/2000	-	-	x	-	-	-	-	-	-	-
Starmers above Pajarito	WT	PF00065E242	Filtered	-	6/28/2000	-	-	x	-	-	x	-	x	-	-

Table C-2.0-2 (continued)

Location ID	Media Description	Sample ID	Field Prep	Field QC Type	Collection Date	DIOX/FUR	DRO	GENINORG	HERB	HEXP	Metals	PEST/PCB	RAD	SVOA	VOA
Starmers above Pajarito	WT	PS00065E242	Unfiltered	-	6/28/2000	-	-	x	-	-	x	x	x	x	-
Starmers above Pajarito	WT	PS00066E242	Unfiltered	Field Duplicate	6/28/2000	-	-	x	-	-	-	-	-	-	-
Starmers above Pajarito	WT	GU02060E24201	Unfiltered	-	6/21/2002	-	-	x	-	-	x	-	-	-	-
Starmers above Pajarito	WT	GF03080E24201	Filtered	-	8/11/2003	-	-	x	-	-	-	-	-	-	-
Starmers above Pajarito	WT	GU03080E24201	Unfiltered	-	8/11/2003	-	-	x	-	-	-	-	-	-	-
Starmers above Pajarito	WT	GU03090E24201	Unfiltered	-	8/28/2003	-	-	x	-	-	-	-	-	-	-
Starmers above Pajarito	WS	GF04060W24201	Filtered	-	6/16/2004	-	-	x	-	-	x	-	-	-	-
Starmers above Pajarito	WS	GU04060W24201	Unfiltered	-	6/16/2004	-	-	x	-	x	x	-	x	-	-
Starmers above Pajarito	WT	GF04070E24201	Filtered	-	7/24/2004	-	-	x	-	-	x	-	-	-	-
Starmers above Pajarito	WT	GU04070E24201	Unfiltered	-	7/24/2004	-	-	x	-	-	x	-	-	-	-
Starmers above Pajarito	WT	GF04100E24201	Filtered	-	10/5/2004	-	-	x	-	-	x	-	-	-	-
Starmers above Pajarito	WT	GU04100E24201	Unfiltered	-	10/5/2004	-	-	x	-	-	x	-	-	-	-
Starmers above Pajarito	WM	GF05030M24201	Filtered	-	3/24/2005	-	-	x	-	-	-	-	-	-	-
Starmers above Pajarito	WM	GU05030M24201	Unfiltered	-	3/24/2005	-	-	x	-	-	x	-	-	-	-
Starmers above Pajarito	WS	GF05060P24201	Filtered	-	6/14/2005	-	-	x	-	-	x	-	x	-	-
Starmers above Pajarito	WS	GU05060P24201	Unfiltered	-	6/14/2005	-	-	x	-	x	x	-	x	-	-
Starmers above Pajarito	WT	GF05070E24201	Filtered	-	7/15/2005	-	-	x	-	-	x	-	-	-	-

Table C-2.0-2 (continued)

Location ID	Media Description	Sample ID	Field Prep	Field QC Type	Collection Date	DIOX/FUR	DRO	GENINORG	HERB	HEXP	Metals	PEST/PCB	RAD	SVOA	VOA
Starmers above Pajarito	WT	GU05070E24201	Unfiltered	-	7/15/2005	-	-	x	-	-	x	-	-	-	-
Starmers above Pajarito	WT	GF060800E24201	Filtered	-	8/11/2006	-	-	x	-	-	x	-	-	-	-
Starmers above Pajarito	WT	GU060800E24201	Unfiltered	-	8/11/2006	-	-	x	-	-	x	-	-	-	-
Starmers above Pajarito	WM	GU070300M24201	Unfiltered	-	3/6/2007	-	-	x	-	-	-	-	-	-	-
Starmers above Pajarito	WT	GF070700E24201	Filtered	-	7/26/2007	-	-	x	-	-	x	-	-	-	-
Starmers above Pajarito	WT	GU070700E24201	Unfiltered	-	7/26/2007	-	-	x	-	-	x	-	x	-	-
Starmers above Pajarito	WT	GF070800E24201	Filtered	-	8/6/2007	-	-	x	-	-	x	-	-	-	-
Starmers above Pajarito	WT	GU070800E24201	Unfiltered	-	8/6/2007	-	-	x	-	-	x	-	x	-	-
Starmers above Pajarito	WT	GF070800E24202	Filtered	-	8/18/2007	-	-	x	-	-	x	-	-	-	-
Starmers above Pajarito	WT	GU070800E24202	Unfiltered	-	8/18/2007	-	-	x	-	-	x	-	x	-	-
Starmers above Pajarito	WT	GF070800E24203	Filtered	-	8/29/2007	-	-	x	-	-	x	-	-	-	-
Starmers above Pajarito	WT	GU070800E24203	Unfiltered	-	8/29/2007	-	-	x	-	-	x	-	x	-	-
Starmer's Gulch above SR-501	WT	GF001012417	Filtered	-	10/23/2000	-	-	x	-	-	x	-	x	-	-
Starmer's Gulch above SR-501	WT	GS001012417	Filtered	-	10/23/2000	-	-	x	-	-	-	-	-	-	-
Starmer's Gulch above SR-501	WT	GS001012417	Unfiltered	-	10/23/2000	x	-	x	-	x	x	-	x	x	x
Starmer's Gulch above SR-501	WT	GS001022417	Unfiltered	Field Duplicate	10/23/2000	-	-	x	-	-	-	-	-	-	-
TA-18 Culvert	WS	WS6705099201	Filtered	-	5/9/1967	-	-	x	-	-	-	-	-	-	-

Table C-2.0-2 (continued)

Location ID	Media Description	Sample ID	Field Prep	Field QC Type	Collection Date	DIOX/FUR	DRO	GENINORG	HERB	HEXP	Metals	PEST/PCB	RAD	SVOA	VOA
TA-18 Culvert	WS	WS6705099201	Unfiltered	-	5/9/1967	-	-	x	-	-	x	-	x	-	-
TA-18 Culvert	WS	WS7105079201	Filtered	-	5/7/1971	-	-	x	-	-	-	-	-	-	-
TA-18 Culvert	WS	WS7105079201	Unfiltered	-	5/7/1971	-	-	x	-	-	-	-	-	-	-
TA-18 Culvert	WS	WS7205039201	Filtered	-	5/3/1972	-	-	x	-	-	-	-	-	-	-
TA-18 Culvert	WS	WS7205039201	Unfiltered	-	5/3/1972	-	-	x	-	-	-	-	-	-	-
TA-18 Culvert	WT	PF00061E18C	Filtered	-	6/28/2000	-	-	x	-	-	x	-	x	-	-
TA-18 Culvert	WT	PS00061E18C	Unfiltered	-	6/28/2000	-	-	x	-	-	x	x	x	x	-
TA-18 Culvert	WT	PS00062E18C	Unfiltered	Field Duplicate	6/28/2000	-	-	x	-	-	-	-	-	-	-
TA-18 STP	WS	WS7306229211	Unfiltered	-	6/22/1973	-	-	-	-	-	x	-	x	-	-
TA-18 STP	WS	WS7310019211	Unfiltered	-	10/1/1973	-	-	-	-	-	x	-	x	-	-
Threemile above Pajarito	WT	GU03080E24601	Unfiltered	-	8/23/2003	-	-	x	-	-	x	-	-	-	-
Threemile above Pajarito	WT	GF04070E24601	Filtered	-	7/23/2004	-	-	x	-	-	x	-	-	-	-
Threemile above Pajarito	WT	GU04070E24601	Unfiltered	-	7/24/2004	-	-	x	-	-	x	-	x	-	-
Threemile above Pajarito	WT	GF04080E24601	Filtered	-	8/20/2004	-	-	x	-	-	x	-	-	-	-
Threemile above Pajarito	WT	GU04080E24601	Unfiltered	-	8/20/2004	-	-	x	-	x	x	x	x	-	-
Threemile above Pajarito	WM	GF05030M24601	Filtered	-	3/21/2005	-	-	x	-	-	-	-	-	-	-
Threemile above Pajarito	WM	GU05030M24601	Unfiltered	-	3/21/2005	-	-	x	-	x	x	x	x	-	-

Table C-2.0-2 (continued)

Location ID	Media Description	Sample ID	Field Prep	Field QC Type	Collection Date	DIOX/FUR	DRO	GENINORG	HERB	HEXP	Metals	PEST/PCB	RAD	SVOA	VOA
Threemile above Pajarito	WT	GF060800E24601	Filtered	-	8/25/2006	-	-	x	-	-	x	-	-	-	-
Threemile above Pajarito	WT	GU060800E24601	Unfiltered	-	8/25/2006	-	-	x	-	x	x	x	x	-	-
Threemile above Pajarito	WT	GF070500E24601	Filtered	-	5/2/2007	-	-	x	-	-	x	-	-	-	-
Threemile above Pajarito	WT	GU070500E24601	Unfiltered	-	5/2/2007	-	-	x	-	x	x	x	x	-	-
Threemile above Pajarito	WT	GF070600E24601	Filtered	-	6/11/2007	-	-	x	-	-	x	-	-	-	-
Threemile above Pajarito	WT	GU070600E24601	Unfiltered	-	6/11/2007	-	-	x	-	-	x	-	x	-	-
Threemile above Pajarito	WT	GF070700E24601	Filtered	-	7/30/2007	-	-	x	-	-	x	-	-	-	-
Threemile above Pajarito	WT	GU070700E24601	Unfiltered	-	7/30/2007	-	-	x	-	x	x	x	x	-	-
Threemile above Pajarito	WM	GF080200M24601	Filtered	-	1/29/2008	-	-	x	-	-	x	-	-	-	-
Threemile above Pajarito	WM	GU080200M24601	Unfiltered	-	1/29/2008	-	-	x	-	-	x	-	x	-	-
Two Mile Canyon below TA-59	WP	GF06080PPBF201	Filtered	-	8/25/2006	-	-	x	-	-	x	-	x	-	-
Two Mile Canyon below TA-59	WP	GU06080PPBF201	Filtered	-	8/25/2006	-	-	x	-	-	-	-	-	-	-
Two Mile Canyon below TA-59	WP	GU06080PPBF201	Unfiltered	-	8/25/2006	-	-	x	x	-	x	x	x	x	x
Two Mile Canyon below TA-59	WP	SU06080PPBF201	Unfiltered	-	8/25/2006	-	-	-	-	x	-	-	-	-	-
Two Mile Canyon below TA-59	WP	UU06080PPBF201	Unfiltered	-	8/25/2006	-	-	-	-	-	-	-	x	-	-

Table C-2.0-2 (continued)

Location ID	Media Description	Sample ID	Field Prep	Field QC Type	Collection Date	DIOX/FUR	DRO	GENINORG	HERB	HEXP	Metals	PEST/PCB	RAD	SVOA	VOA
Two Mile Canyon below TA-59	WS	GF07030PPBF201	Filtered	-	4/2/2007	-	-	x	-	-	x	-	x	-	-
Two Mile Canyon below TA-59	WS	GU07030PPBF201	Unfiltered	-	4/2/2007	-	-	x	-	x	x	x	x	x	x
Two Mile Canyon below TA-59	WS	SU07030PPBF201	Unfiltered	-	4/2/2007	-	-	-	-	x	-	-	-	-	-
Two Mile Canyon below TA-59	WS	UU07030PPBF201	Unfiltered	-	4/2/2007	-	-	-	-	-	-	-	x	-	-
Two Mile Canyon below TA-59	WS	GF07060PPBF201	Filtered	-	6/27/2007	-	-	x	-	-	x	-	x	-	-
Two Mile Canyon below TA-59	WS	GU07060PPBF201	Unfiltered	-	6/27/2007	-	-	x	-	x	x	x	x	x	x
Two Mile Canyon below TA-59	WS	SU07060PPBF201	Unfiltered	-	6/27/2007	-	-	-	-	x	-	-	-	-	-
Two Mile Canyon below TA-59	WP	UU07060PPBF201	Unfiltered	-	6/27/2007	-	-	-	-	-	-	-	x	-	-
Two Mile Canyon below TA-59	WS	GF07090PPBF201	Filtered	-	9/11/2007	-	-	x	-	-	x	-	x	-	-
Two Mile Canyon below TA-59	WS	GU07090PPBF201	Unfiltered	-	9/11/2007	-	-	x	x	x	x	x	x	x	x
Two Mile Canyon below TA-59	WP	SU07090PPBF201	Unfiltered	-	9/11/2007	-	-	-	-	x	-	-	-	-	-
Two Mile Canyon below TA-59	WP	UU07090PPBF201	Unfiltered	-	9/11/2007	-	-	-	-	-	-	-	x	-	-
Two Mile Canyon below TA-59	WS	CAPA-08-9345	Filtered	-	12/19/2007	-	-	x	-	-	x	-	x	-	-
Two Mile Canyon below TA-59	WS	CAPA-08-9347	Unfiltered	-	12/19/2007	-	-	x	-	x	x	x	x	x	x
Two Mile Canyon below TA-59	WS	CAPA-08-13035	Filtered	-	6/12/2008	-	-	x	-	-	x	-	x	-	-
Two Mile Canyon below TA-59	WS	CAPA-08-13037	Unfiltered	-	6/12/2008	-	-	x	-	x	x	x	x	x	x
Twomile above Pajarito	WM	GF04040M24401	Filtered	-	4/27/2004	-	-	x	-	-	x	-	-	-	-

Table C-2.0-2 (continued)

Location ID	Media Description	Sample ID	Field Prep	Field QC Type	Collection Date	DIOX/FUR	DRO	GENINORG	HERB	HEXP	Metals	PEST/PCB	RAD	SVOA	VOA
Twomile above Pajarito	WM	GU04040M24401	Unfiltered	-	4/27/2004	x	-	x	-	x	x	x	x	-	-
Twomile above Pajarito	WT	GF04070E24401	Filtered	-	7/23/2004	-	-	x	-	-	x	-	-	-	-
Twomile above Pajarito	WT	GU04070E24401	Unfiltered	-	7/23/2004	-	-	x	-	-	x	-	x	-	-
Twomile above Pajarito	WT	GF04080E24401	Filtered	-	8/18/2004	-	-	x	-	-	x	-	-	-	-
Twomile above Pajarito	WT	GU04080E24401	Unfiltered	-	8/18/2004	-	-	x	-	-	x	-	x	-	-
Twomile above Pajarito	WM	GF05030M24401	Filtered	-	3/22/2005	-	-	x	-	-	-	-	-	-	-
Twomile above Pajarito	WM	GU05030M24401	Unfiltered	-	3/22/2005	x	-	x	-	x	x	x	x	-	-
Twomile above Pajarito	WT	GF05070E24401	Filtered	-	7/15/2005	-	-	x	-	-	x	-	-	-	-
Twomile above Pajarito	WT	GF05070E24490	Filtered	Field Duplicate	7/15/2005	-	-	x	-	-	x	-	-	-	-
Twomile above Pajarito	WT	GU05070E24401	Unfiltered	-	7/15/2005	-	-	x	-	-	x	-	-	-	-
Twomile above Pajarito	WT	GU05070E24490	Unfiltered	Field Duplicate	7/15/2005	-	-	x	-	-	x	-	-	-	-
Twomile above Pajarito	WT	GF05080E24401	Filtered	-	8/22/2005	-	-	x	-	-	x	-	-	-	-
Twomile above Pajarito	WT	GU05080E24401	Unfiltered	-	8/22/2005	x	-	x	-	x	x	-	-	-	-
Twomile above Pajarito	WT	GU05080E24490	Unfiltered	Field Duplicate	8/22/2005	-	-	-	-	x	-	-	-	-	-
Twomile above Pajarito	WT	GF05080E24402	Filtered	-	8/24/2005	-	-	x	-	-	x	-	-	-	-

Table C-2.0-2 (continued)

Location ID	Media Description	Sample ID	Field Prep	Field QC Type	Collection Date	DIOX/FUR	DRO	GENINORG	HERB	HEXP	Metals	PEST/PCB	RAD	SVOA	VOA
Twomile above Pajarito	WT	GU05080E24402	Unfiltered	-	8/24/2005	-	-	x	-	x	x	x	-	-	-
Twomile above Pajarito	WT	GF05100E24401	Filtered	-	9/28/2005	-	-	x	-	-	-	-	-	-	-
Twomile above Pajarito	WT	GU05100E24401	Unfiltered	-	9/28/2005	x	-	x	-	-	x	x	-	-	-
Twomile above Pajarito	WT	GF060700E24401	Filtered	-	6/29/2006	-	-	x	-	-	x	-	-	-	-
Twomile above Pajarito	WT	GU060700E24401	Unfiltered	-	6/29/2006	x	-	x	-	x	x	x	-	-	-
Twomile above Pajarito	WT	GF060800E24401	Filtered	-	8/1/2006	-	-	x	-	-	x	-	-	-	-
Twomile above Pajarito	WT	GU060800E24401	Unfiltered	-	8/1/2006	-	-	x	-	x	x	x	-	-	-
Twomile above Pajarito	WT	GF060800E24402	Filtered	-	8/7/2006	-	-	x	-	-	x	-	-	-	-
Twomile above Pajarito	WT	GU060800E24402	Unfiltered	-	8/7/2006	-	-	x	-	x	x	x	-	-	-
Twomile above Pajarito	WT	GU060800E24403	Unfiltered	-	8/19/2006	-	-	x	-	-	-	-	-	-	-
Twomile above Pajarito	WT	GF060800E24403	Filtered	-	8/25/2006	-	-	x	-	-	x	-	-	-	-
Twomile above Pajarito	WT	GU060800E24404	Unfiltered	-	8/25/2006	-	-	x	-	x	x	x	x	-	-
Twomile above Pajarito	WP	GF060800P24401	Filtered	-	8/29/2006	-	-	x	-	-	x	-	x	-	-
Twomile above Pajarito	WP	GU060800P24401	Filtered	-	8/29/2006	-	-	x	-	-	-	-	-	-	-
Twomile above Pajarito	WP	GU060800P24401	Unfiltered	-	8/29/2006	-	-	x	x	-	x	x	x	x	x
Twomile above Pajarito	WP	SU060800P24401	Unfiltered	-	8/29/2006	-	-	-	-	x	-	-	-	-	-
Twomile above Pajarito	WP	UU060800P24401	Unfiltered	-	8/29/2006	-	-	-	-	-	-	-	x	-	-

Table C-2.0-2 (continued)

Location ID	Media Description	Sample ID	Field Prep	Field QC Type	Collection Date	DIOX/FUR	DRO	GENINORG	HERB	HEXP	Metals	PEST/PCB	RAD	SVOA	VOA
Twomile above Pajarito	WT	GU060900E24401	Unfiltered	-	9/1/2006	-	-	x	-	-	-	-	x	-	-
Twomile above Pajarito	WT	GF061000E24401	Filtered	-	10/9/2006	-	-	x	-	-	-	-	-	-	-
Twomile above Pajarito	WT	GU061000E24401	Unfiltered	-	10/9/2006	-	-	x	-	-	-	-	x	-	-
Twomile above Pajarito	WT	AU070300E24401	Unfiltered	-	3/23/2007	x	-	-	-	-	-	-	-	-	-
Twomile above Pajarito	WT	GF070300E24401	Filtered	-	3/23/2007	-	-	x	-	-	x	-	-	-	-
Twomile above Pajarito	WT	GU070300E24401	Unfiltered	-	3/23/2007	-	-	x	-	-	x	x	x	-	-
Twomile above Pajarito	WS	GF070300P24401	Filtered	-	4/3/2007	-	-	x	-	-	x	-	x	-	-
Twomile above Pajarito	WS	GU070300P24401	Unfiltered	-	4/3/2007	-	-	x	-	x	x	x	-	x	x
Twomile above Pajarito	WP	GU070300P24402	Unfiltered	-	4/3/2007	-	-	-	-	-	-	-	x	-	-
Twomile above Pajarito	WS	SU070300P24401	Unfiltered	-	4/3/2007	-	-	-	-	x	-	-	-	-	-
Twomile above Pajarito	WS	UU070300P24401	Unfiltered	-	4/3/2007	-	-	-	-	-	-	-	x	-	-
Twomile above Pajarito	WT	AU070600E24401	Unfiltered	-	6/16/2007	x	-	-	-	-	-	-	-	-	-
Twomile above Pajarito	WT	GF070600E24401	Filtered	-	6/16/2007	-	-	x	-	-	x	-	-	-	-
Twomile above Pajarito	WT	GU070600E24401	Unfiltered	-	6/16/2007	-	-	x	-	-	x	-	x	-	-
Twomile above Pajarito	WS	GF070600P24401	Filtered	-	6/27/2007	-	-	x	-	-	x	-	x	-	-
Twomile above Pajarito	WS	GU070600P24401	Unfiltered	-	6/27/2007	-	-	x	-	x	x	x	x	x	x
Twomile above Pajarito	WS	SU070600P24401	Unfiltered	-	6/27/2007	-	-	-	-	x	-	-	-	-	-

Table C-2.0-2 (continued)

Location ID	Media Description	Sample ID	Field Prep	Field QC Type	Collection Date	DIOX/FUR	DRO	GENINORG	HERB	HEXP	Metals	PEST/PCB	RAD	SVOA	VOA
Twomile above Pajarito	WP	UU070600P24401	Unfiltered	-	6/27/2007	-	-	-	-	-	-	-	x	-	-
Twomile above Pajarito	WT	AU070700E24401	Unfiltered	-	7/14/2007	x	-	-	-	-	-	-	-	-	-
Twomile above Pajarito	WT	GF070700E24401	Filtered	-	7/14/2007	-	-	x	-	-	x	-	-	-	-
Twomile above Pajarito	WT	GU070700E24401	Unfiltered	-	7/14/2007	-	-	x	-	x	x	x	x	-	-
Twomile above Pajarito	WT	AU070700E24402	Unfiltered	-	7/26/2007	x	-	-	-	-	-	-	-	-	-
Twomile above Pajarito	WT	GF070700E24402	Filtered	-	7/26/2007	-	-	x	-	-	x	-	-	-	-
Twomile above Pajarito	WT	GU070700E24402	Unfiltered	-	7/26/2007	-	-	x	-	x	x	x	x	-	-
Twomile above Pajarito	WT	GU070700E24403	Unfiltered	-	7/30/2007	-	-	x	-	x	-	-	-	-	-
Twomile above Pajarito	WP	GF070900P24401	Filtered	-	9/12/2007	-	-	x	-	-	x	-	x	-	-
Twomile above Pajarito	WP	GU070900P24401	Unfiltered	-	9/12/2007	-	-	x	x	x	x	x	x	x	x
Twomile above Pajarito	WP	SU070900P24401	Unfiltered	-	9/12/2007	-	-	-	-	x	-	-	-	-	-
Twomile above Pajarito	WP	UU070900P24401	Unfiltered	-	9/12/2007	-	-	-	-	-	-	-	x	-	-
Twomile above Pajarito	WS	CAPA-08-9265	Filtered	-	12/17/2007	-	-	x	-	-	x	-	x	-	-
Twomile above Pajarito	WS	CAPA-08-9267	Unfiltered	-	12/17/2007	-	-	x	-	x	x	x	x	x	x
Twomile above Pajarito	WM	GF080100M24401	Filtered	-	1/29/2008	-	-	x	-	-	x	-	-	-	-
Twomile above Pajarito	WM	GU080100M24401	Unfiltered	-	1/29/2008	-	-	x	-	-	x	-	x	-	-
Twomile above Pajarito	WS	CAPA-08-10999	Filtered	-	3/5/2008	-	-	x	-	-	x	-	x	-	-

Table C-2.0-2 (continued)

Location ID	Media Description	Sample ID	Field Prep	Field QC Type	Collection Date	DIOX/FUR	DRO	GENINORG	HERB	HEXP	Metals	PEST/PCB	RAD	SVOA	VOA
Twomile above Pajarito	WS	CAPA-08-11000	Unfiltered	-	3/5/2008	-	-	x	-	x	x	x	x	x	x
Twomile above SR-501	WT	GF001012436	Filtered	-	10/23/2000	-	-	x	-	-	x	-	x	-	-
Twomile above SR-501	WT	GS001012436	Filtered	-	10/23/2000	-	-	x	-	-	-	-	-	-	-
Twomile above SR-501	WT	GS001012436	Unfiltered	-	10/23/2000	x	-	x	-	x	x	x	x	x	x
Twomile above SR-501	WT	GS001022436	Unfiltered	Field Duplicate	10/23/2000	-	-	x	-	-	-	-	-	-	-

^a - = Analysis was not performed.

^b x = Analysis was performed.

**Table C-2.0-3
Pajarito Canyon Watershed Groundwater Samples Collected**

Location ID	Top Depth (ft)	Bottom Depth (ft)	Media Description	Sample ID	Field Prep	Field QC Type	Collection Date	DIOX/FUR	DRO	Geninorg	GRO	Herb	HEXP	Isotope	Metals	Pest/PCB	RAD	S/VOA	VOA
03-B-10	20.6	30.6	WGI	GU06060G3B1001	UF	- ^a	6/27/2006	-	-	x ^b	-	-	-	-	x	-	x	-	x
03-B-10	20.6	30.6	WGI	GU06060G3B1090	UF	Field Duplicate	6/27/2006	-	-	-	-	-	-	-	-	-	x	-	-
03-B-10	20.6	30.6	WGI	GF06060G3B1001	F	-	6/27/2006	-	-	x	-	-	-	-	x	-	-	-	-
03-B-10	20.6	30.6	WGI	GF06060G3B1090	F	Field Duplicate	6/27/2006	-	-	-	-	-	-	-	-	-	x	-	-
03-B-10	20.6	30.6	WGI	GU06080G3B1001	UF	-	8/23/2006	-	x	x	-	x	x	-	x	x	x	x	x
03-B-10	20.6	30.6	WGI	GF06080G3B1001	F	-	8/23/2006	-	-	x	-	-	-	-	x	-	x	-	-
03-B-10	20.6	30.6	WGI	SU06080G3B1001	UF	-	8/23/2006	-	-	-	-	-	x	-	-	-	-	-	-
03-B-10	20.6	30.6	WGI	GU06080G3B1001	F	-	8/23/2006	-	-	x	-	-	-	-	-	-	-	-	-
03-B-10	20.6	30.6	WGI	GU06120G3B1001	UF	-	12/14/2006	-	x	x	-	-	x	-	x	x	x	x	x
03-B-10	20.6	30.6	WGI	GF06120G3B1001	F	-	12/14/2006	-	-	x	-	-	-	-	x	-	x	-	-
03-B-10	20.6	30.6	WGI	SU06120G3B1001	UF	-	12/14/2006	-	-	-	-	-	x	-	-	-	-	-	-
03-B-10	20.6	30.6	WGI	GU06120G3B1001	F	-	12/14/2006	-	-	x	-	-	-	-	-	-	-	-	-
03-B-10	20.6	30.6	WGI	GU07030G3B1001	UF	-	3/29/2007	-	x	x	x	-	x	-	x	x	x	x	x
03-B-10	20.6	30.6	WGI	GF07030G3B1001	F	-	3/29/2007	-	-	x	-	-	-	-	x	-	x	-	-
03-B-10	20.6	30.6	WGI	SU07030G3B1001	UF	-	3/29/2007	-	-	-	-	-	x	-	-	-	-	-	-

Table C-2.0-3 (continued)

Location ID	Top Depth (ft)	Bottom Depth (ft)	Media Description	Sample ID	Field Prep	Field QC Type	Collection Date	DIOX/FUR	DRO	GENINORG	GRO	Herb	HEXP	Isotope	Metals	Pest/PCB	RAD	S/VOA	VOA
03-B-10	20.6	30.6	WGI	GU07060G3B1001	UF	-	7/10/2007	-	x	x	x	-	x	-	x	x	x	x	x
03-B-10	20.6	30.6	WGI	GF07060G3B1001	F	-	7/10/2007	-	-	x	-	-	-	-	x	-	x	-	-
03-B-10	20.6	30.6	WGI	SU07060G3B1001	UF	-	7/10/2007	-	-	-	-	-	x	-	-	-	-	-	-
03-B-10	20.6	30.6	WGI	GU07090G3B1001	UF	-	9/18/2007	-	x	x	x	x	x	-	x	x	x	x	x
03-B-10	20.6	30.6	WGI	GF07090G3B1001	F	-	9/18/2007	-	-	x	-	-	-	-	x	-	x	-	-
03-B-10	20.6	30.6	WGI	SU07090G3B1001	UF	-	9/18/2007	-	-	-	-	-	x	-	-	-	-	-	-
03-B-10	20.6	30.6	WGI	CAPA-08-9319	UF	-	12/17/2007	-	x	x	x	-	x	-	x	x	x	x	x
03-B-10	20.6	30.6	WGI	CAPA-08-9317	F	-	12/17/2007	-	-	x	-	-	-	-	x	-	x	-	-
03-B-10	20.6	30.6	WGI	CAPA-08-13138	UF	-	6/12/2008	-	-	x	-	-	x	-	x	x	x	x	x
03-B-10	20.6	30.6	WGI	CAPA-08-13137	F	-	6/12/2008	-	-	x	-	-	-	-	x	-	x	-	-
03-B-10	n/p ^c	n/p	WGI	CAPA-08-11017	UF	-	3/17/2008	-	-	x	-	-	x	-	x	x	x	x	x
03-B-10	n/p	n/p	WGI	CAPA-08-11018	F	-	3/17/2008	-	-	x	-	-	-	-	x	-	x	-	-
03-B-13	21.5	31.5	WGI	GU06060G3B1301	UF	-	6/23/2006	-	-	x	-	-	x	-	x	x	x	x	x
03-B-13	21.5	31.5	WGI	GU06060G3B1390	UF	Field Duplicate	6/23/2006	-	-	x	-	-	x	-	x	x	x	x	x
03-B-13	21.5	31.5	WGI	GF06060G3B1301	F	-	6/23/2006	-	-	x	-	-	-	-	x	-	x	-	-

Table C-2.0-3 (continued)

Location ID	Top Depth (ft)	Bottom Depth (ft)	Media Description	Sample ID	Field Prep	Field QC Type	Collection Date	DIOX/FUR	DRO	GENINORG	GRO	Herb	HEXP	Isotope	Metals	Pest/PCB	RAD	SVOA	VOA
03-B-13	21.5	31.5	WGI	GF06060G3B1390	F	Field Duplicate	6/23/2006	-	-	x	-	-	-	-	x	-	x	-	-
03-B-13	21.5	31.5	WGI	SU06060G3B1301	UF	-	6/23/2006	-	-	-	-	-	x	-	-	-	-	-	-
03-B-13	21.5	31.5	WGI	SU06060G3B1390	UF	Field Duplicate	6/23/2006	-	-	-	-	-	x	-	-	-	-	-	-
03-B-13	21.5	31.5	WGI	GU06060G3B1301	F	-	6/23/2006	-	-	x	-	-	-	-	-	-	-	-	-
03-B-13	21.5	31.5	WGI	GU06060G3B1390	F	Field Duplicate	6/23/2006	-	-	x	-	-	-	-	-	-	-	-	-
03-B-13	21.5	31.5	WGI	GF06060G3B1302	F	-	6/23/2006	-	-	x	-	-	-	-	-	-	-	-	-
03-B-13	21.5	31.5	WGI	GF06060G3B1391	F	Field Duplicate	6/23/2006	-	-	x	-	-	-	-	-	-	-	-	-
03-B-13	21.5	31.5	WGI	GU06060G3B1302	UF	-	6/23/2006	-	x	-	-	-	-	-	-	-	-	-	-
03-B-13	21.5	31.5	WGI	GU06060G3B1391	UF	Field Duplicate	6/23/2006	-	x	-	-	-	-	-	-	-	-	-	-
03-B-13	21.5	31.5	WGI	GU06080G3B1301	UF	-	8/24/2006	-	x	x	-	x	x	-	x	x	x	x	x
03-B-13	21.5	31.5	WGI	GF06080G3B1301	F	-	8/24/2006	-	-	x	-	-	-	-	x	-	x	-	-
03-B-13	21.5	31.5	WGI	SU06080G3B1301	UF	-	8/24/2006	-	-	-	-	-	x	-	-	-	-	-	-
03-B-13	21.5	31.5	WGI	GU06080G3B1301	F	-	8/24/2006	-	-	x	-	-	-	-	-	-	-	-	-

Table C-2.0-3 (continued)

Location ID	Top Depth (ft)	Bottom Depth (ft)	Media Description	Sample ID	Field Prep	Field QC Type	Collection Date	DIOX/FUR	DRO	GENINORG	GRO	Herb	HEXP	Isotope	Metals	Pest/PCB	RAD	SVOA	VOA
03-B-13	21.5	31.5	WGI	GU06120G3B1301	UF	-	12/18/2006	-	x	x	-	-	x	-	x	x	x	x	x
03-B-13	21.5	31.5	WGI	GF06120G3B1301	F	-	12/18/2006	-	-	x	-	-	-	-	x	-	x	-	-
03-B-13	21.5	31.5	WGI	SU06120G3B1301	UF	-	12/18/2006	-	-	-	-	-	x	-	-	-	-	-	-
03-B-13	21.5	31.5	WGI	GU06120G3B1301	F	-	12/18/2006	-	-	x	-	-	-	-	-	-	-	-	-
03-B-13	21.5	31.5	WGI	GU07030G3B1301	UF	-	3/29/2007	-	x	x	x	-	x	-	x	x	x	x	x
03-B-13	21.5	31.5	WGI	GF07030G3B1301	F	-	3/29/2007	-	-	x	-	-	-	-	x	-	x	-	-
03-B-13	21.5	31.5	WGI	SU07030G3B1301	UF	-	3/29/2007	-	-	-	-	-	x	-	-	-	-	-	-
03-B-13	21.5	31.5	WGI	GU07060G3B1301	UF	-	7/10/2007	-	x	x	x	-	x	-	x	x	x	x	x
03-B-13	21.5	31.5	WGI	GF07060G3B1301	F	-	7/10/2007	-	-	x	-	-	-	-	x	-	x	-	-
03-B-13	21.5	31.5	WGI	SU07060G3B1301	UF	-	7/10/2007	-	-	-	-	-	x	-	-	-	-	-	-
03-B-13	21.5	31.5	WGI	GU07090G3B1301	UF	-	9/14/2007	-	x	x	x	x	x	-	x	x	x	x	x
03-B-13	21.5	31.5	WGI	GF07090G3B1301	F	-	9/14/2007	-	-	x	-	-	-	-	x	-	x	-	-
03-B-13	21.5	31.5	WGI	SU07090G3B1301	UF	-	9/14/2007	-	-	-	-	-	x	-	-	-	-	-	-
03-B-13	21.5	31.5	WGI	CAPA-08-9316	UF	-	12/18/2007	-	x	x	x	-	x	-	x	x	x	x	x
03-B-13	21.5	31.5	WGI	CAPA-08-9315	F	-	12/18/2007	-	-	x	-	-	-	-	x	-	x	-	-
03-B-13	21.5	31.5	WGI	CAPA-08-13143	UF	-	6/12/2008	-	-	x	-	-	x	-	x	x	x	x	x

Table C-2.0-3 (continued)

Location ID	Top Depth (ft)	Bottom Depth (ft)	Media Description	Sample ID	Field Prep	Field QC Type	Collection Date	DIOX/FUR	DRO	GENINORG	GRO	Herb	HEXP	Isotope	Metals	Pest/PCB	RAD	SVOA	VOA
03-B-13	21.5	31.5	WGI	CAPA-08-13145	UF	Field Duplicate	6/12/2008	-	-	x	-	-	x	-	x	x	x	x	x
03-B-13	21.5	31.5	WGI	CAPA-08-13142	F	-	6/12/2008	-	-	x	-	-	-	-	x	-	x	-	-
03-B-13	21.5	31.5	WGI	CAPA-08-13144	F	Field Duplicate	6/12/2008	-	-	x	-	-	-	-	x	-	x	-	-
03-B-13	n/p	n/p	WGI	CAPA-08-11020	UF	-	3/17/2008	-	-	x	-	-	x	-	x	x	x	x	x
03-B-13	n/p	n/p	WGI	CAPA-08-11022	F	-	3/17/2008	-	-	x	-	-	-	-	x	-	x	-	-
03-B-9	21.3	31.3	WGI	GU070700G3B901	UF	-	7/11/2007	-	x	x	x	-	-	-	x	x	x	-	x
03-B-9	21.3	31.3	WGI	GF070700G3B901	F	-	7/11/2007	-	-	x	-	-	-	-	x	-	-	-	-
03-B-9	21.3	31.3	WGI	GU070900G3B901	UF	-	9/17/2007	-	x	x	x	x	x	-	x	x	x	x	x
03-B-9	21.3	31.3	WGI	GF070900G3B901	F	-	9/17/2007	-	-	x	-	-	-	-	x	-	x	-	-
03-B-9	21.3	31.3	WGI	SU070900G3B901	UF	-	9/17/2007	-	-	-	-	-	x	-	-	-	-	-	-
18-BG-1	10	35	WGA	GU06080G18B101	UF	-	8/29/2006	-	-	x	-	x	x	-	x	x	x	x	x
18-BG-1	10	35	WGA	UU06080G18B101	UF	-	8/29/2006	-	-	-	-	-	-	-	-	-	x	-	-
18-BG-1	10	35	WGA	GF06080G18B101	F	-	8/29/2006	-	-	x	-	-	-	-	x	-	x	-	-
18-BG-1	10	35	WGA	SU06080G18B101	UF	-	8/29/2006	-	-	-	-	-	x	-	-	-	-	-	-
18-BG-1	10	35	WGA	GU06080G18B101	F	-	8/29/2006	-	-	x	-	-	-	-	-	-	-	-	-

Table C-2.0-3 (continued)

Location ID	Top Depth (ft)	Bottom Depth (ft)	Media Description	Sample ID	Field Prep	Field QC Type	Collection Date	DIOX/FUR	DRO	GENINORG	GRO	Herb	HEXP	Isotope	Metals	Pest/PCB	RAD	SVOA	VOA
18-BG-1	10	35	WGA	GU06120G18B101	UF	-	12/8/2006	-	-	x	-	-	x	-	x	x	x	x	x
18-BG-1	10	35	WGA	GU06120G18B120	UF	Field Duplicate	12/8/2006	-	-	x	-	-	x	-	x	x	x	x	x
18-BG-1	10	35	WGA	UU06120G18B101	UF	-	12/8/2006	-	-	-	-	-	-	-	-	-	x	-	-
18-BG-1	10	35	WGA	UU06120G18B120	UF	Field Duplicate	12/8/2006	-	-	-	-	-	-	-	-	-	x	-	-
18-BG-1	10	35	WGA	GF06120G18B101	F	-	12/8/2006	-	-	x	-	-	-	-	x	-	x	-	-
18-BG-1	10	35	WGA	GF06120G18B120	F	Field Duplicate	12/8/2006	-	-	x	-	-	-	-	x	-	x	-	-
18-BG-1	10	35	WGA	SU06120G18B101	UF	-	12/8/2006	-	-	-	-	-	x	-	-	-	-	-	-
18-BG-1	10	35	WGA	SU06120G18B120	UF	Field Duplicate	12/8/2006	-	-	-	-	-	x	-	-	-	-	-	-
18-BG-1	10	35	WGA	GU06120G18B101	F	-	12/8/2006	-	-	x	-	-	-	-	-	-	-	-	-
18-BG-1	10	35	WGA	GU06120G18B120	F	Field Duplicate	12/8/2006	-	-	x	-	-	-	-	-	-	-	-	-
18-BG-1	10	35	WGA	GU07030G18B101	UF	-	3/20/2007	-	-	x	-	-	x	-	x	x	x	x	x
18-BG-1	10	35	WGA	UU07030G18B101	UF	-	3/20/2007	-	-	-	-	-	-	-	-	-	x	-	-
18-BG-1	10	35	WGA	GF07030G18B101	F	-	3/20/2007	-	-	x	-	-	-	-	x	-	x	-	-

Table C-2.0-3 (continued)

Location ID	Top Depth (ft)	Bottom Depth (ft)	Media Description	Sample ID	Field Prep	Field QC Type	Collection Date	DIOX/FUR	DRO	GENINORG	GRO	Herb	HEXP	Isotope	Metals	Pest/PCB	RAD	SVOA	VOA
18-BG-1	10	35	WGA	SU07030G18B101	UF	-	3/20/2007	-	-	-	-	-	X	-	-	-	-	-	-
18-BG-1	10	35	WGA	GU07060G18B101	UF	-	6/28/2007	-	-	X	-	-	X	-	X	X	X	X	X
18-BG-1	10	35	WGA	UU07060G18B101	UF	-	6/28/2007	-	-	-	-	-	-	-	-	-	X	-	-
18-BG-1	10	35	WGA	GF07060G18B101	F	-	6/28/2007	-	-	X	-	-	-	X	-	-	X	-	-
18-BG-1	10	35	WGA	SU07060G18B101	UF	-	6/28/2007	-	-	-	-	-	X	-	-	-	-	-	-
18-BG-1	10	35	WGA	GU07090G18B101	UF	-	9/10/2007	-	-	X	-	X	X	-	X	X	X	X	X
18-BG-1	10	35	WGA	UU07090G18B101	UF	-	9/10/2007	-	-	-	-	-	-	-	-	-	X	-	-
18-BG-1	10	35	WGA	GF07090G18B101	F	-	9/10/2007	-	-	X	-	-	-	X	-	-	X	-	-
18-BG-1	10	35	WGA	SU07090G18B101	UF	-	9/10/2007	-	-	-	-	-	X	-	-	-	-	-	-
18-BG-1	10	35	WGA	CAPA-08-9353	UF	-	12/4/2007	-	-	X	-	-	X	-	X	X	X	X	X
18-BG-1	10	35	WGA	CAPA-08-9352	F	-	12/4/2007	-	-	X	-	-	-	X	-	-	X	-	-
18-BG-1	10	35	WGA	CAPA-08-13527	UF	-	6/20/2008	-	-	X	-	-	X	-	X	X	X	X	X
18-BG-1	10	35	WGA	CAPA-08-13530	F	-	6/20/2008	-	-	X	-	-	-	X	-	-	X	-	-
18-BG-1	n/p	n/p	WGA	CAPA-08-10936	UF	-	3/4/2008	-	-	X	-	-	X	-	X	X	X	X	X
18-BG-1	n/p	n/p	WGA	CAPA-08-10935	F	-	3/4/2008	-	-	X	-	-	-	X	-	-	X	-	-
18-BG-4	n/p	n/p	WGA	CAPA-08-10957	UF	-	3/12/2008	-	-	-	-	-	X	-	-	-	-	-	X

Table C-2.0-3 (continued)

Location ID	Top Depth (ft)	Bottom Depth (ft)	Media Description	Sample ID	Field Prep	Field QC Type	Collection Date	DIOX/FUR	DRO	GENINORG	GRO	Herb	HEXP	Isotope	Metals	Pest/PCB	RAD	SVOA	VOA
18-MW-11	27	47	WGA	GU06080G181101	UF	-	8/31/2006	-	-	x	-	x	x	-	x	x	x	x	x
18-MW-11	27	47	WGA	UU06080G181101	UF	-	8/31/2006	-	-	-	-	-	-	-	-	-	x	-	-
18-MW-11	27	47	WGA	GF06080G181101	F	-	8/31/2006	-	-	x	-	-	-	-	x	-	x	-	-
18-MW-11	27	47	WGA	SU06080G181101	UF	-	8/31/2006	-	-	-	-	-	x	-	-	-	-	-	-
18-MW-11	27	47	WGA	GU06080G181101	F	-	8/31/2006	-	-	x	-	-	-	-	-	-	-	-	-
18-MW-11	27	47	WGA	GU06120G181101	UF	-	12/12/2006	-	-	x	-	-	x	-	x	x	x	x	x
18-MW-11	27	47	WGA	GF06120G181101	F	-	12/12/2006	-	-	x	-	-	-	-	x	-	x	-	-
18-MW-11	27	47	WGA	SU06120G181101	UF	-	12/12/2006	-	-	-	-	-	x	-	-	-	-	-	-
18-MW-11	27	47	WGA	GU06120G181101	F	-	12/12/2006	-	-	x	-	-	-	-	-	-	-	-	-
18-MW-11	27	47	WGA	GU07030G181101	UF	-	3/28/2007	-	-	x	-	-	x	-	x	x	x	x	x
18-MW-11	27	47	WGA	UU07030G181101	UF	-	3/28/2007	-	-	-	-	-	-	-	-	-	x	-	-
18-MW-11	27	47	WGA	GF07030G181101	F	-	3/28/2007	-	-	x	-	-	-	-	x	-	x	-	-
18-MW-11	27	47	WGA	SU07030G181101	UF	-	3/28/2007	-	-	-	-	-	x	-	-	-	-	-	-
18-MW-11	27	47	WGA	GU07060G181101	UF	-	7/3/2007	-	-	x	-	-	x	-	x	x	x	x	x
18-MW-11	27	47	WGA	UU07060G181101	UF	-	7/3/2007	-	-	-	-	-	-	-	-	-	x	-	-
18-MW-11	27	47	WGA	GF07060G181101	F	-	7/3/2007	-	-	x	-	-	-	-	x	-	x	-	-

Table C-2.0-3 (continued)

Location ID	Top Depth (ft)	Bottom Depth (ft)	Media Description	Sample ID	Field Prep	Field QC Type	Collection Date	DIOX/FUR	DRO	GENINORG	GRO	Herb	HEXP	Isotope	Metals	Pest/PCB	RAD	SVOA	VOA
18-MW-11	27	47	WGA	SU07060G181101	UF	-	7/3/2007	-	-	-	-	-	x	-	-	-	-	-	-
18-MW-11	27	47	WGA	GU07090G181101	UF	-	9/13/2007	-	-	x	-	x	x	-	x	x	x	x	x
18-MW-11	27	47	WGA	GU07090G181120	UF	Field Duplicate	9/13/2007	-	-	x	-	x	x	-	x	x	x	x	x
18-MW-11	27	47	WGA	UU07090G181101	UF	-	9/13/2007	-	-	-	-	-	-	-	-	-	x	-	-
18-MW-11	27	47	WGA	UU07090G181120	UF	Field Duplicate	9/13/2007	-	-	-	-	-	-	-	-	-	x	-	-
18-MW-11	27	47	WGA	GF07090G181101	F	-	9/13/2007	-	-	x	-	-	-	-	x	-	x	-	-
18-MW-11	27	47	WGA	GF07090G181120	F	Field Duplicate	9/13/2007	-	-	x	-	-	-	-	x	-	x	-	-
18-MW-11	27	47	WGA	SU07090G181101	UF	-	9/13/2007	-	-	-	-	-	x	-	-	-	-	-	-
18-MW-11	27	47	WGA	SU07090G181120	UF	Field Duplicate	9/13/2007	-	-	-	-	-	x	-	-	-	-	-	-
18-MW-11	27	47	WGA	CAPA-08-9341	UF	-	12/5/2007	-	-	x	-	-	x	-	x	x	x	x	x
18-MW-11	27	47	WGA	CAPA-08-9343	F	-	12/5/2007	-	-	x	-	-	-	-	x	-	x	-	-
18-MW-11	27	47	WGA	CAPA-08-13089	UF	-	6/17/2008	-	-	x	-	-	x	-	x	x	x	x	x
18-MW-11	27	47	WGA	CAPA-08-13091	F	-	6/17/2008	-	-	x	-	-	-	-	x	-	x	-	-
18-MW-11	n/p	n/p	WGA	CAPA-08-11105	UF	-	3/5/2008	-	-	x	-	-	x	-	x	x	x	x	x

Table C-2.0-3 (continued)

Location ID	Top Depth (ft)	Bottom Depth (ft)	Media Description	Sample ID	Field Prep	Field QC Type	Collection Date	DIOX/FUR	DRO	GENINORG	GRO	Herb	HEXP	Isotope	Metals	Pest/PCB	RAD	SVOA	VOA
18-MW-11	n/p	n/p	WGA	CAPA-08-11107	F	-	3/5/2008	-	-	x	-	-	-	-	x	-	x	-	-
18-MW-18	12.5	23	WGA	GU06080G181801	UF	-	8/28/2006	-	-	x	-	x	x	-	x	x	x	x	x
18-MW-18	12.5	23	WGA	UU06080G181801	UF	-	8/28/2006	-	-	-	-	-	-	-	-	-	x	-	-
18-MW-18	12.5	23	WGA	GF06080G181801	F	-	8/28/2006	-	-	x	-	-	-	-	x	-	x	-	-
18-MW-18	12.5	23	WGA	SU06080G181801	UF	-	8/28/2006	-	-	-	-	-	x	-	-	-	-	-	-
18-MW-18	12.5	23	WGA	GU06080G181801	F	-	8/28/2006	-	-	x	-	-	-	-	-	-	-	-	-
18-MW-18	12.5	23	WGA	GU06120G181801	UF	-	12/7/2006	-	-	x	-	-	x	-	x	x	x	x	x
18-MW-18	12.5	23	WGA	UU06120G181801	UF	-	12/7/2006	-	-	-	-	-	-	-	-	-	x	-	-
18-MW-18	12.5	23	WGA	GF06120G181801	F	-	12/7/2006	-	-	x	-	-	-	-	x	-	x	-	-
18-MW-18	12.5	23	WGA	SU06120G181801	UF	-	12/7/2006	-	-	-	-	-	x	-	-	-	-	-	-
18-MW-18	12.5	23	WGA	GU06120G181801	F	-	12/7/2006	-	-	x	-	-	-	-	-	-	-	-	-
18-MW-18	12.5	23	WGA	GU07030G181801	UF	-	3/19/2007	-	-	x	-	-	x	-	x	x	x	x	x
18-MW-18	12.5	23	WGA	UU07030G181801	UF	-	3/19/2007	-	-	-	-	-	-	-	-	-	x	-	-
18-MW-18	12.5	23	WGA	GF07030G181801	F	-	3/19/2007	-	-	x	-	-	-	-	x	-	x	-	-
18-MW-18	12.5	23	WGA	SU07030G181801	UF	-	3/19/2007	-	-	-	-	-	x	-	-	-	-	-	-
18-MW-18	12.5	23	WGA	GU07060G181801	UF	-	6/26/2007	-	-	x	-	-	x	-	x	x	x	x	x

Table C-2.0-3 (continued)

Location ID	Top Depth (ft)	Bottom Depth (ft)	Media Description	Sample ID	Field Prep	Field QC Type	Collection Date	DIOX/FUR	DRO	GENINORG	GRO	Herb	HEXP	Isotope	Metals	Pest/PCB	RAD	SVOA	VOA
18-MW-18	12.5	23	WGA	GU07060G181820	UF	Field Duplicate	6/26/2007	-	-	x	-	-	x	-	x	x	x	x	x
18-MW-18	12.5	23	WGA	UU07060G181801	UF	-	6/26/2007	-	-	-	-	-	-	-	-	-	x	-	-
18-MW-18	12.5	23	WGA	UU07060G181820	UF	Field Duplicate	6/26/2007	-	-	-	-	-	-	-	-	-	x	-	-
18-MW-18	12.5	23	WGA	GF07060G181801	F	-	6/26/2007	-	-	x	-	-	-	-	x	-	x	-	-
18-MW-18	12.5	23	WGA	GF07060G181820	F	Field Duplicate	6/26/2007	-	-	x	-	-	-	-	x	-	x	-	-
18-MW-18	12.5	23	WGA	SU07060G181801	UF	-	6/26/2007	-	-	-	-	-	x	-	-	-	-	-	-
18-MW-18	12.5	23	WGA	SU07060G181820	UF	Field Duplicate	6/26/2007	-	-	-	-	-	x	-	-	-	-	-	-
18-MW-18	12.5	23	WGA	GU07090G181801	UF	-	9/12/2007	-	-	x	-	x	x	-	x	x	x	x	x
18-MW-18	12.5	23	WGA	UU07090G181801	UF	-	9/12/2007	-	-	-	-	-	-	-	-	-	x	-	-
18-MW-18	12.5	23	WGA	GF07090G181801	F	-	9/12/2007	-	-	x	-	-	-	-	x	-	x	-	-
18-MW-18	12.5	23	WGA	SU07090G181801	UF	-	9/12/2007	-	-	-	-	-	x	-	-	-	-	-	-
18-MW-18	12.5	23	WGA	CAPA-08-9305	UF	-	12/6/2007	-	-	x	-	-	x	-	x	x	x	x	x
18-MW-18	12.5	23	WGA	CAPA-08-9306	F	-	12/6/2007	-	-	x	-	-	-	-	x	-	x	-	-
18-MW-18	12.5	23	WGA	CAPA-08-13099	UF	-	6/10/2008	-	-	x	-	-	x	-	x	x	x	x	x

Table C-2.0-3 (continued)

Location ID	Top Depth (ft)	Bottom Depth (ft)	Media Description	Sample ID	Field Prep	Field QC Type	Collection Date	DIOX/FUR	DRO	GENINORG	GRO	Herb	HEXP	Isotope	Metals	Pest/PCB	RAD	SVOA	VOA
18-MW-18	12.5	23	WGA	CAPA-08-13100	F	-	6/10/2008	-	-	x	-	-	-	-	x	-	x	-	-
18-MW-18	n/p	n/p	WGA	CAPA-08-10941	UF	-	3/3/2008	-	-	x	-	-	x	-	x	x	x	x	x
18-MW-18	n/p	n/p	WGA	CAPA-08-10943	F	-	3/3/2008	-	-	x	-	-	-	-	x	-	x	-	-
18-MW-8	8	38	WGA	GU06080G18M801	UF	-	8/30/2006	-	-	x	-	x	x	-	x	x	x	x	x
18-MW-8	8	38	WGA	GU06080G18M890	UF	Field Duplicate	8/30/2006	-	-	x	-	x	x	-	x	x	x	x	x
18-MW-8	8	38	WGA	UU06080G18M801	UF	-	8/30/2006	-	-	-	-	-	-	-	-	-	x	-	-
18-MW-8	8	38	WGA	UU06080G18M890	UF	Field Duplicate	8/30/2006	-	-	-	-	-	-	-	-	-	x	-	-
18-MW-8	8	38	WGA	GF06080G18M801	F	-	8/30/2006	-	-	x	-	-	-	-	x	-	x	-	-
18-MW-8	8	38	WGA	GF06080G18M890	F	Field Duplicate	8/30/2006	-	-	x	-	-	-	-	x	-	x	-	-
18-MW-8	8	38	WGA	SU06080G18M801	UF	-	8/30/2006	-	-	-	-	-	x	-	-	-	-	-	-
18-MW-8	8	38	WGA	SU06080G18M890	UF	Field Duplicate	8/30/2006	-	-	-	-	-	x	-	-	-	-	-	-
18-MW-8	8	38	WGA	GU06080G18M801	F	-	8/30/2006	-	-	x	-	-	-	-	-	-	-	-	-
18-MW-8	8	38	WGA	GU06080G18M890	F	Field Duplicate	8/30/2006	-	-	x	-	-	-	-	-	-	-	-	-

Table C-2.0-3 (continued)

Location ID	Top Depth (ft)	Bottom Depth (ft)	Media Description	Sample ID	Field Prep	Field QC Type	Collection Date	DIOX/FUR	DRO	GENINORG	GRO	Herb	HEXP	Isotope	Metals	Pest/PCB	RAD	SVOA	VOA
18-MW-8	8	38	WGA	GU06120G18M801	UF	-	12/11/2006	-	-	x	-	-	x	-	x	x	x	x	x
18-MW-8	8	38	WGA	UU06120G18M801	UF	-	12/11/2006	-	-	-	-	-	-	-	-	-	x	-	-
18-MW-8	8	38	WGA	GF06120G18M801	F	-	12/11/2006	-	-	x	-	-	-	-	x	-	x	-	-
18-MW-8	8	38	WGA	SU06120G18M801	UF	-	12/11/2006	-	-	-	-	-	x	-	-	-	-	-	-
18-MW-8	8	38	WGA	GU06120G18M801	F	-	12/11/2006	-	-	x	-	-	-	-	-	-	-	-	-
18-MW-8	8	38	WGA	GU07030G18M801	UF	-	3/21/2007	-	-	x	-	-	x	-	x	x	x	x	x
18-MW-8	8	38	WGA	GU07030G18M820	UF	Field Duplicate	3/21/2007	-	-	x	-	-	x	-	x	x	x	x	x
18-MW-8	8	38	WGA	UU07030G18M801	UF	-	3/21/2007	-	-	-	-	-	-	-	-	-	x	-	-
18-MW-8	8	38	WGA	UU07030G18M820	UF	Field Duplicate	3/21/2007	-	-	-	-	-	-	-	-	-	x	-	-
18-MW-8	8	38	WGA	GF07030G18M801	F	-	3/21/2007	-	-	x	-	-	-	-	x	-	x	-	-
18-MW-8	8	38	WGA	GF07030G18M820	F	Field Duplicate	3/21/2007	-	-	x	-	-	-	-	x	-	x	-	-
18-MW-8	8	38	WGA	SU07030G18M801	UF	-	3/21/2007	-	-	-	-	-	x	-	-	-	-	-	-
18-MW-8	8	38	WGA	SU07030G18M820	UF	Field Duplicate	3/21/2007	-	-	-	-	-	x	-	-	-	-	-	-
18-MW-8	8	38	WGA	GU07060G18M801	UF	-	6/27/2007	-	-	x	-	-	x	-	x	x	x	x	x

Table C-2.0-3 (continued)

Location ID	Top Depth (ft)	Bottom Depth (ft)	Media Description	Sample ID	Field Prep	Field QC Type	Collection Date	DIOX/FUR	DRO	GENINORG	GRO	Herb	HEXP	Isotope	Metals	Pest/PCB	RAD	SVOA	VOA
18-MW-8	8	38	WGA	UU07060G18M801	UF	-	6/27/2007	-	-	-	-	-	-	-	-	-	X	-	-
18-MW-8	8	38	WGA	GF07060G18M801	F	-	6/27/2007	-	-	X	-	-	-	-	X	-	X	-	-
18-MW-8	8	38	WGA	SU07060G18M801	UF	-	6/27/2007	-	-	-	-	-	X	-	-	-	-	-	-
18-MW-8	8	38	WGA	GU07090G18M801	UF	-	9/13/2007	-	-	X	-	X	X	-	X	X	X	X	X
18-MW-8	8	38	WGA	UU07090G18M801	UF	-	9/13/2007	-	-	-	-	-	-	-	-	-	X	-	-
18-MW-8	8	38	WGA	GF07090G18M801	F	-	9/13/2007	-	-	X	-	-	-	-	X	-	X	-	-
18-MW-8	8	38	WGA	SU07090G18M801	UF	-	9/13/2007	-	-	-	-	-	X	-	-	-	-	-	-
18-MW-8	8	38	WGA	CAPA-08-9310	UF	-	12/5/2007	-	-	X	-	-	X	-	X	X	X	X	X
18-MW-8	8	38	WGA	CAPA-08-9309	F	-	12/5/2007	-	-	X	-	-	-	-	X	-	X	-	-
18-MW-8	8	38	WGA	CAPA-08-13095	UF	-	6/16/2008	-	-	X	-	-	X	-	X	X	X	X	X
18-MW-8	8	38	WGA	CAPA-08-13098	F	-	6/16/2008	-	-	X	-	-	-	-	X	-	X	-	-
18-MW-8	n/p	n/p	WGA	CAPA-08-10938	UF	-	3/3/2008	-	-	X	-	-	X	-	X	X	X	X	X
18-MW-8	n/p	n/p	WGA	CAPA-08-10940	F	-	3/3/2008	-	-	X	-	-	-	-	X	-	X	-	-
18-MW-9	6	31	WGA	GU06080G18M901	UF	-	8/31/2006	-	-	X	-	X	X	-	X	X	X	X	X
18-MW-9	6	31	WGA	UU06080G18M901	UF	-	8/31/2006	-	-	-	-	-	-	-	-	-	X	-	-
18-MW-9	6	31	WGA	GF06080G18M901	F	-	8/31/2006	-	-	X	-	-	-	-	X	-	X	-	-

Table C-2.0-3 (continued)

Location ID	Top Depth (ft)	Bottom Depth (ft)	Media Description	Sample ID	Field Prep	Field QC Type	Collection Date	DIOX/FUR	DRO	GENINORG	GRO	Herb	HEXP	Isotope	Metals	Pest/PCB	RAD	SVOA	VOA
18-MW-9	6	31	WGA	SU06080G18M901	UF	-	8/31/2006	-	-	-	-	-	X	-	-	-	-	-	-
18-MW-9	6	31	WGA	GU06080G18M901	F	-	8/31/2006	-	-	X	-	-	-	-	-	-	-	-	-
18-MW-9	6	31	WGA	GU06120G18M901	UF	-	12/11/2006	-	-	X	-	-	X	-	X	X	X	X	X
18-MW-9	6	31	WGA	UU06120G18M901	UF	-	12/11/2006	-	-	-	-	-	-	-	-	-	X	-	-
18-MW-9	6	31	WGA	GF06120G18M901	F	-	12/11/2006	-	-	X	-	-	-	-	X	-	X	-	-
18-MW-9	6	31	WGA	SU06120G18M901	UF	-	12/11/2006	-	-	-	-	-	X	-	-	-	-	-	-
18-MW-9	6	31	WGA	GU06120G18M901	F	-	12/11/2006	-	-	X	-	-	-	-	-	-	-	-	-
18-MW-9	6	31	WGA	GU07030G18M901	UF	-	3/22/2007	-	-	X	-	-	X	-	X	X	X	X	X
18-MW-9	6	31	WGA	UU07030G18M901	UF	-	3/22/2007	-	-	-	-	-	-	-	-	-	X	-	-
18-MW-9	6	31	WGA	GF07030G18M901	F	-	3/22/2007	-	-	X	-	-	-	-	X	-	X	-	-
18-MW-9	6	31	WGA	SU07030G18M901	UF	-	3/22/2007	-	-	-	-	-	X	-	-	-	-	-	-
18-MW-9	6	31	WGA	GU07060G18M901	UF	-	6/28/2007	-	-	X	-	-	X	-	X	X	X	X	X
18-MW-9	6	31	WGA	UU07060G18M901	UF	-	6/28/2007	-	-	-	-	-	-	-	-	-	X	-	-
18-MW-9	6	31	WGA	GF07060G18M901	F	-	6/28/2007	-	-	X	-	-	-	-	X	-	X	-	-
18-MW-9	6	31	WGA	SU07060G18M901	UF	-	6/28/2007	-	-	-	-	-	X	-	-	-	-	-	-
18-MW-9	6	31	WGA	GU07090G18M901	UF	-	9/12/2007	-	-	X	-	X	X	-	X	X	X	X	X

Table C-2.0-3 (continued)

Location ID	Top Depth (ft)	Bottom Depth (ft)	Media Description	Sample ID	Field Prep	Field QC Type	Collection Date	DIOX/FUR	DRO	GENINORG	GRO	Herb	HEXP	Isotope	Metals	Pest/PCB	RAD	SVOA	VOA
18-MW-9	6	31	WGA	GU07090G18M920	UF	Field Duplicate	9/12/2007	-	-	x	-	x	x	-	x	x	x	x	x
18-MW-9	6	31	WGA	UU07090G18M901	UF	-	9/12/2007	-	-	-	-	-	-	-	-	-	x	-	-
18-MW-9	6	31	WGA	UU07090G18M920	UF	Field Duplicate	9/12/2007	-	-	-	-	-	-	-	-	-	x	-	-
18-MW-9	6	31	WGA	GF07090G18M901	F	-	9/12/2007	-	-	x	-	-	-	-	x	-	x	-	-
18-MW-9	6	31	WGA	GF07090G18M920	F	Field Duplicate	9/12/2007	-	-	x	-	-	-	-	x	-	x	-	-
18-MW-9	6	31	WGA	SU07090G18M901	UF	-	9/12/2007	-	-	-	-	-	x	-	-	-	-	-	-
18-MW-9	6	31	WGA	CAPA-08-9362	UF	-	12/18/2007	-	-	x	-	-	x	-	x	x	x	x	x
18-MW-9	6	31	WGA	CAPA-08-9364	UF	Field Duplicate	12/18/2007	-	-	x	-	-	x	-	x	x	x	x	x
18-MW-9	6	31	WGA	CAPA-08-9360	F	-	12/18/2007	-	-	x	-	-	-	-	x	-	x	-	-
18-MW-9	6	31	WGA	CAPA-08-9365	F	Field Duplicate	12/18/2007	-	-	x	-	-	-	-	x	-	x	-	-
18-MW-9	6	31	WGA	CAPA-08-13084	UF	-	6/11/2008	-	-	x	-	-	x	-	x	x	x	x	x
18-MW-9	6	31	WGA	CAPA-08-13085	F	-	6/11/2008	-	-	x	-	-	-	-	x	-	x	-	-
18-MW-9	n/p	n/p	WGA	CAPA-08-10950	UF	-	3/19/2008	-	-	x	-	-	x	-	x	x	x	x	x

Table C-2.0-3 (continued)

Location ID	Top Depth (ft)	Bottom Depth (ft)	Media Description	Sample ID	Field Prep	Field QC Type	Collection Date	DIOX/FUR	DRO	GENINORG	GRO	Herb	HEXP	Isotope	Metals	Pest/PCB	RAD	SVOA	VOA
18-MW-9	n/p	n/p	WGA	CAPA-08-10952	F	-	3/19/2008	-	-	x	-	-	-	-	x	-	x	-	-
3MAO-2	14.7	24.7	WGA	CAPA-08-13125	UF	-	6/23/2008	-	-	x	-	x	x	-	x	x	x	x	x
3MAO-2	14.7	24.7	WGA	CAPA-08-13126	F	-	6/23/2008	-	-	x	-	-	-	-	x	-	x	-	-
Anderson Spring	0	0	WGS	GU06080GANDS01	UF	-	8/22/2006	-	-	x	-	x	x	-	x	x	x	x	x
Anderson Spring	0	0	WGS	UU06080GANDS01	UF	-	8/22/2006	-	-	-	-	-	-	-	-	-	x	-	-
Anderson Spring	0	0	WGS	GF06080GANDS01	F	-	8/22/2006	-	-	x	-	-	-	-	x	-	x	-	-
Anderson Spring	0	0	WGS	SU06080GANDS01	UF	-	8/22/2006	-	-	-	-	-	x	-	-	-	-	-	-
Anderson Spring	0	0	WGS	GU06080GANDS01	F	-	8/22/2006	-	-	x	-	-	-	-	-	-	-	-	-
Anderson Spring	0	0	WGS	GU06120GANDS01	UF	-	12/11/2006	-	-	x	-	-	x	-	x	x	x	x	x
Anderson Spring	0	0	WGS	UU06120GANDS01	UF	-	12/11/2006	-	-	-	-	-	-	-	-	-	x	-	-
Anderson Spring	0	0	WGS	GF06120GANDS01	F	-	12/11/2006	-	-	x	-	-	-	-	x	-	x	-	-
Anderson Spring	0	0	WGS	SU06120GANDS01	UF	-	12/11/2006	-	-	-	-	-	x	-	-	-	-	-	-
Anderson Spring	0	0	WGS	GU06120GANDS01	F	-	12/11/2006	-	-	x	-	-	-	-	-	-	-	-	-
Anderson Spring	0	0	WGS	GU07030GANDS01	UF	-	3/27/2007	-	-	x	-	-	x	-	x	x	x	x	x
Anderson Spring	0	0	WGS	UU07030GANDS01	UF	-	3/27/2007	-	-	-	-	-	-	-	-	-	x	-	-
Anderson Spring	0	0	WGS	GF07030GANDS01	F	-	3/27/2007	-	-	x	-	-	-	-	x	-	x	-	-

Table C-2.0-3 (continued)

Location ID	Top Depth (ft)	Bottom Depth (ft)	Media Description	Sample ID	Field Prep	Field QC Type	Collection Date	DIOX/FUR	DRO	GENINORG	GRO	Herb	HEXP	Isotope	Metals	Pest/PCB	RAD	SVOA	VOA
Anderson Spring	0	0	WGS	SU07030GANDS01	UF	-	3/27/2007	-	-	-	-	-	X	-	-	-	-	-	-
Anderson Spring	0	0	WGS	GU07060GANDS01	UF	-	7/6/2007	-	-	X	-	-	X	-	X	X	X	X	X
Anderson Spring	0	0	WGS	GF07060GANDS01	F	-	7/6/2007	-	-	X	-	-	-	-	X	-	X	-	-
Anderson Spring	0	0	WGS	SU07060GANDS01	UF	-	7/6/2007	-	-	-	-	-	X	-	-	-	-	-	-
Anderson Spring	0	0	WGS	GU07090GANDS01	UF	-	9/11/2007	-	-	X	-	X	X	-	X	X	X	X	X
Anderson Spring	0	0	WGS	UU07090GANDS01	UF	-	9/11/2007	-	-	-	-	-	-	-	-	-	X	-	-
Anderson Spring	0	0	WGS	GF07090GANDS01	F	-	9/11/2007	-	-	X	-	-	-	-	X	-	X	-	-
Anderson Spring	0	0	WGS	SU07090GANDS01	UF	-	9/11/2007	-	-	-	-	-	X	-	-	-	-	-	-
Anderson Spring	0	0	WGS	CAPA-08-9287	UF	-	12/10/2007	-	-	X	-	-	X	-	X	X	X	X	X
Anderson Spring	0	0	WGS	CAPA-08-9288	F	-	12/10/2007	-	-	X	-	-	-	-	X	-	X	-	-
Anderson Spring	0	0	WGA	CAPA-08-13058	UF	-	6/10/2008	-	-	X	-	-	X	-	X	X	X	X	X
Anderson Spring	0	0	WGA	CAPA-08-13060	F	-	6/10/2008	-	-	X	-	-	-	-	X	-	X	-	-
Bulldog Spring	0	0	WGS	GU04070GSLB01	UF	-	9/9/2004	-	-	X	-	-	X	-	X	X	X	X	X
Bulldog Spring	0	0	WGS	GF04070GSLB01	F	-	9/9/2004	-	-	X	-	-	-	-	X	-	X	-	-
Bulldog Spring	0	0	WGS	GU05060GSLB01	UF	-	6/22/2005	-	-	X	-	-	X	-	X	X	X	X	-
Bulldog Spring	0	0	WGS	GF05060GSLB01	F	-	6/22/2005	-	-	X	-	-	-	-	X	-	X	-	-

Table C-2.0-3 (continued)

Location ID	Top Depth (ft)	Bottom Depth (ft)	Media Description	Sample ID	Field Prep	Field QC Type	Collection Date	DIOX/FUR	DRO	GENINORG	GRO	Herb	HEXP	Isotope	Metals	Pest/PCB	RAD	SVOA	VOA
Bulldog Spring	0	0	WGS	GU060800GSLB01	UF	-	8/30/2006	-	-	x	-	x	x	-	x	x	x	x	x
Bulldog Spring	0	0	WGS	UU060800GSLB01	UF	-	8/30/2006	-	-	-	-	-	-	-	-	-	x	-	-
Bulldog Spring	0	0	WGS	GF060800GSLB01	F	-	8/30/2006	-	-	x	-	-	-	-	x	-	x	-	-
Bulldog Spring	0	0	WGS	SU060800GSLB01	UF	-	8/30/2006	-	-	-	-	-	x	-	-	-	-	-	-
Bulldog Spring	0	0	WGS	GU060800GSLB01	F	-	8/30/2006	-	-	x	-	-	-	-	-	-	-	-	-
Bulldog Spring	0	0	WGS	GU061200GSLB01	UF	-	12/7/2006	-	-	x	-	-	x	-	x	x	x	x	x
Bulldog Spring	0	0	WGS	UU061200GSLB01	UF	-	12/7/2006	-	-	-	-	-	-	-	-	-	x	-	-
Bulldog Spring	0	0	WGS	GF061200GSLB01	F	-	12/7/2006	-	-	x	-	-	-	-	x	-	x	-	-
Bulldog Spring	0	0	WGS	SU061200GSLB01	UF	-	12/7/2006	-	-	-	-	-	x	-	-	-	-	-	-
Bulldog Spring	0	0	WGS	GU061200GSLB01	F	-	12/7/2006	-	-	x	-	-	-	-	-	-	-	-	-
Bulldog Spring	0	0	WGS	GU070300GSLB01	UF	-	3/26/2007	-	-	x	-	-	x	-	x	x	x	x	x
Bulldog Spring	0	0	WGS	UU070300GSLB01	UF	-	3/26/2007	-	-	-	-	-	-	-	-	-	x	-	-
Bulldog Spring	0	0	WGS	GF070300GSLB01	F	-	3/26/2007	-	-	x	-	-	-	-	x	-	x	-	-
Bulldog Spring	0	0	WGS	SU070300GSLB01	UF	-	3/26/2007	-	-	-	-	-	x	-	-	-	-	-	-
Bulldog Spring	0	0	WGS	GU070600GSLB01	UF	-	7/10/2007	-	-	x	-	-	x	-	x	x	x	x	x
Bulldog Spring	0	0	WGS	UU070600GSLB01	UF	-	7/10/2007	-	-	-	-	-	-	-	-	-	x	-	-

Table C-2.0-3 (continued)

Location ID	Top Depth (ft)	Bottom Depth (ft)	Media Description	Sample ID	Field Prep	Field QC Type	Collection Date	DIOX/FUR	DRO	GENINORG	GRO	Herb	HEXP	Isotope	Metals	Pest/PCB	RAD	SVOA	VOA
Bulldog Spring	0	0	WGS	GF070600GSLB01	F	-	7/10/2007	-	-	x	-	-	-	-	x	-	x	-	-
Bulldog Spring	0	0	WGS	SU070600GSLB01	UF	-	7/10/2007	-	-	-	-	-	x	-	-	-	-	-	-
Bulldog Spring	0	0	WGS	GU070800GSLB01	UF	-	9/4/2007	-	-	x	-	x	x	-	x	x	x	x	x
Bulldog Spring	0	0	WGS	UU070800GSLB01	UF	-	9/4/2007	-	-	-	-	-	-	-	-	-	x	-	-
Bulldog Spring	0	0	WGS	GF070800GSLB01	F	-	9/4/2007	-	-	x	-	-	-	-	x	-	x	-	-
Bulldog Spring	0	0	WGS	SU070800GSLB01	UF	-	9/4/2007	-	-	-	-	-	x	-	-	-	-	-	-
Bulldog Spring	0	0	WGS	CAPA-08-9215	UF	-	12/3/2007	-	-	x	-	-	x	-	x	x	x	x	x
Bulldog Spring	0	0	WGS	CAPA-08-9216	F	-	12/3/2007	-	-	x	-	-	-	-	x	-	x	-	-
Bulldog Spring	0	0	WGS	CAPA-08-10975	F	-	3/11/2008	-	-	x	-	-	-	-	x	-	x	-	-
Bulldog Spring	0	0	WGA	CAPA-08-13071	UF	-	6/10/2008	-	-	x	-	-	x	-	x	x	x	x	x
Bulldog Spring	0	0	WGA	CAPA-08-13069	F	-	6/10/2008	-	-	x	-	-	-	-	x	-	x	-	-
Bulldog Spring	n/p	n/p	WGS	CAPA-08-10974	UF	-	3/11/2008	-	-	x	-	-	x	-	x	x	x	x	x
Charlie's Spring	0	0	WGS	GU06080GCHRS01	UF	-	8/31/2006	-	-	x	-	x	x	-	x	x	x	x	x
Charlie's Spring	0	0	WGS	UU06080GCHRS01	UF	-	8/31/2006	-	-	-	-	-	-	-	-	-	x	-	-
Charlie's Spring	0	0	WGS	GF06080GCHRS01	F	-	8/31/2006	-	-	x	-	-	-	-	x	-	x	-	-
Charlie's Spring	0	0	WGS	SU06080GCHRS01	UF	-	8/31/2006	-	-	-	-	-	x	-	-	-	-	-	-

Table C-2.0-3 (continued)

Location ID	Top Depth (ft)	Bottom Depth (ft)	Media Description	Sample ID	Field Prep	Field QC Type	Collection Date	DIOX/FUR	DRO	GENINORG	GRO	Herb	HEXP	Isotope	Metals	Pest/PCB	RAD	SVOA	VOA
Charlie's Spring	0	0	WGS	GU06080GCHRS01	F	-	8/31/2006	-	-	x	-	-	-	-	-	-	-	-	-
Charlie's Spring	0	0	WGS	GU06120GCHRS01	UF	-	12/6/2006	-	-	x	-	-	x	-	x	x	x	x	x
Charlie's Spring	0	0	WGS	UU06120GCHRS01	UF	-	12/6/2006	-	-	-	-	-	-	-	-	-	x	-	-
Charlie's Spring	0	0	WGS	GF06120GCHRS01	F	-	12/6/2006	-	-	x	-	-	-	-	x	-	x	-	-
Charlie's Spring	0	0	WGS	SU06120GCHRS01	UF	-	12/6/2006	-	-	-	-	-	x	-	-	-	-	-	-
Charlie's Spring	0	0	WGS	GU06120GCHRS01	F	-	12/6/2006	-	-	x	-	-	-	-	-	-	-	-	-
Charlie's Spring	0	0	WGS	GU07030GCHRS01	UF	-	3/21/2007	-	-	x	-	-	x	-	x	x	x	x	x
Charlie's Spring	0	0	WGS	UU07030GCHRS01	UF	-	3/21/2007	-	-	-	-	-	-	-	-	-	x	-	-
Charlie's Spring	0	0	WGS	GF07030GCHRS01	F	-	3/21/2007	-	-	x	-	-	-	-	x	-	x	-	-
Charlie's Spring	0	0	WGS	SU07030GCHRS01	UF	-	3/21/2007	-	-	-	-	-	x	-	-	-	-	-	-
Charlie's Spring	0	0	WGS	GU07060GCHRS01	UF	-	7/9/2007	-	-	x	-	-	x	-	x	x	x	x	x
Charlie's Spring	0	0	WGS	UU07060GCHRS01	UF	-	7/9/2007	-	-	-	-	-	-	-	-	-	x	-	-
Charlie's Spring	0	0	WGS	GF07060GCHRS01	F	-	7/9/2007	-	-	x	-	-	-	-	x	-	x	-	-
Charlie's Spring	0	0	WGS	SU07060GCHRS01	UF	-	7/9/2007	-	-	-	-	-	x	-	-	-	-	-	-
Charlie's Spring	0	0	WGS	GU07080GCHRS01	UF	-	9/5/2007	-	-	x	-	x	x	-	x	x	x	x	x
Charlie's Spring	0	0	WGS	UU07080GCHRS01	UF	-	9/5/2007	-	-	-	-	-	-	-	-	-	x	-	-

Table C-2.0-3 (continued)

Location ID	Top Depth (ft)	Bottom Depth (ft)	Media Description	Sample ID	Field Prep	Field QC Type	Collection Date	DIOX/FUR	DRO	GENINORG	GRO	Herb	HEXP	Isotope	Metals	Pest/PCB	RAD	SVOA	VOA
Charlie's Spring	0	0	WGS	GF07080GCHRS01	F	-	9/5/2007	-	-	x	-	-	-	-	x	-	x	-	-
Charlie's Spring	0	0	WGS	SU07080GCHRS01	UF	-	9/5/2007	-	-	-	-	-	x	-	-	-	-	-	-
Charlie's Spring	0	0	WGS	CAPA-08-9224	UF	-	12/3/2007	-	-	x	-	-	x	-	x	x	x	x	x
Charlie's Spring	0	0	WGS	CAPA-08-9225	F	-	12/3/2007	-	-	x	-	-	-	-	x	-	x	-	-
Charlie's Spring	0	0	WGA	CAPA-08-13066	UF	-	6/19/2008	-	-	x	-	-	x	-	x	x	x	x	x
Charlie's Spring	0	0	WGA	CAPA-08-13068	F	-	6/19/2008	-	-	x	-	-	-	-	x	-	x	-	-
Homestead Spring	0	0	WGS	GU04070GSMH01	UF	-	9/9/2004	-	-	x	-	-	-	-	x	x	x	x	x
Homestead Spring	0	0	WGS	GF04070GSMH01	F	-	9/9/2004	-	-	x	-	-	-	-	x	-	x	-	-
Homestead Spring	0	0	WGS	GU05060GSMH01	UF	-	6/20/2005	-	-	x	-	-	x	-	x	x	x	x	x
Homestead Spring	0	0	WGS	GU05060GSMH90	UF	Field Duplicate	6/20/2005	-	-	x	-	-	x	-	x	x	x	x	x
Homestead Spring	0	0	WGS	GF05060GSMH01	F	-	6/20/2005	-	-	x	-	-	-	-	x	-	x	-	-
Homestead Spring	0	0	WGS	GF05060GSMH90	F	Field Duplicate	6/20/2005	-	-	x	-	-	-	-	x	-	x	-	-
Homestead Spring	0	0	WGS	GU060800GSMH01	UF	-	8/23/2006	-	-	x	-	x	x	-	x	x	x	x	x
Homestead Spring	0	0	WGS	GU060800GSMH90	UF	Field Duplicate	8/23/2006	-	-	x	-	x	x	-	x	x	x	x	x
Homestead Spring	0	0	WGS	UU060800GSMH01	UF	-	8/23/2006	-	-	-	-	-	-	-	-	-	x	-	-

Table C-2.0-3 (continued)

Location ID	Top Depth (ft)	Bottom Depth (ft)	Media Description	Sample ID	Field Prep	Field QC Type	Collection Date	DIOX/FUR	DRO	GENINORG	GRO	Herb	HEXP	Isotope	Metals	Pest/PCB	RAD	SVOA	VOA
Homestead Spring	0	0	WGS	UU060800GSMH90	UF	Field Duplicate	8/23/2006	-	-	-	-	-	-	-	-	-	x	-	-
Homestead Spring	0	0	WGS	GF060800GSMH01	F	-	8/23/2006	-	-	x	-	-	-	-	x	-	x	-	-
Homestead Spring	0	0	WGS	GF060800GSMH90	F	Field Duplicate	8/23/2006	-	-	x	-	-	-	-	x	-	x	-	-
Homestead Spring	0	0	WGS	SU060800GSMH01	UF	-	8/23/2006	-	-	-	-	-	x	-	-	-	-	-	-
Homestead Spring	0	0	WGS	SU060800GSMH90	UF	Field Duplicate	8/23/2006	-	-	-	-	-	x	-	-	-	-	-	-
Homestead Spring	0	0	WGS	GU060800GSMH01	F	-	8/23/2006	-	-	x	-	-	-	-	-	-	-	-	-
Homestead Spring	0	0	WGS	GU060800GSMH90	F	Field Duplicate	8/23/2006	-	-	x	-	-	-	-	-	-	-	-	-
Homestead Spring	0	0	WGS	GU061200GSMH01	UF	-	12/12/2006	-	-	x	-	-	x	-	x	x	x	x	x
Homestead Spring	0	0	WGS	GU061200GSMH20	UF	Field Duplicate	12/12/2006	-	-	x	-	-	x	-	x	x	x	x	x
Homestead Spring	0	0	WGS	UU061200GSMH01	UF	-	12/12/2006	-	-	-	-	-	-	-	-	-	x	-	-
Homestead Spring	0	0	WGS	UU061200GSMH20	UF	Field Duplicate	12/12/2006	-	-	-	-	-	-	-	-	-	x	-	-
Homestead Spring	0	0	WGS	GF061200GSMH01	F	-	12/12/2006	-	-	x	-	-	-	-	x	-	x	-	-
Homestead Spring	0	0	WGS	GF061200GSMH20	F	Field	12/12/2006	-	-	x	-	-	-	-	x	-	x	-	-

Table C-2.0-3 (continued)

Location ID	Top Depth (ft)	Bottom Depth (ft)	Media Description	Sample ID	Field Prep	Field QC Type	Collection Date	DIOX/FUR	DRO	GENINORG	GRO	Herb	HEXP	Isotope	Metals	Pest/PCB	RAD	SVOA	VOA
						Duplicate													
Homestead Spring	0	0	WGS	SU061200GSMH01	UF	-	12/12/2006	-	-	-	-	-	x	-	-	-	-	-	-
Homestead Spring	0	0	WGS	SU061200GSMH20	UF	Field Duplicate	12/12/2006	-	-	-	-	-	x	-	-	-	-	-	-
Homestead Spring	0	0	WGS	GU061200GSMH01	F	-	12/12/2006	-	-	x	-	-	-	-	-	-	-	-	-
Homestead Spring	0	0	WGS	GU061200GSMH20	F	Field Duplicate	12/12/2006	-	-	x	-	-	-	-	-	-	-	-	-
Homestead Spring	0	0	WGS	GU070300GSMH01	UF	-	3/21/2007	-	-	x	-	-	x	-	x	x	x	x	x
Homestead Spring	0	0	WGS	UU070300GSMH01	UF	-	3/21/2007	-	-	-	-	-	-	-	-	-	x	-	-
Homestead Spring	0	0	WGS	GF070300GSMH01	F	-	3/21/2007	-	-	x	-	-	-	-	x	-	x	-	-
Homestead Spring	0	0	WGS	SU070300GSMH01	UF	-	3/21/2007	-	-	-	-	-	x	-	-	-	-	-	-
Homestead Spring	0	0	WGS	GU070600GSMH01	UF	-	7/9/2007	-	-	x	-	-	x	-	x	x	x	x	x
Homestead Spring	0	0	WGS	GU070600GSMH20	UF	Field Duplicate	7/9/2007	-	-	x	-	-	x	-	x	x	x	x	x
Homestead Spring	0	0	WGS	UU070600GSMH01	UF	-	7/9/2007	-	-	-	-	-	-	-	-	-	x	-	-
Homestead Spring	0	0	WGS	UU070600GSMH20	UF	Field Duplicate	7/9/2007	-	-	-	-	-	-	-	-	-	x	-	-
Homestead Spring	0	0	WGS	GF070600GSMH01	F	-	7/9/2007	-	-	x	-	-	-	-	x	-	x	-	-

Table C-2.0-3 (continued)

Location ID	Top Depth (ft)	Bottom Depth (ft)	Media Description	Sample ID	Field Prep	Field QC Type	Collection Date	DIOX/FUR	DRO	GENINORG	GRO	Herb	HEXP	Isotope	Metals	Pest/PCB	RAD	SVOA	VOA
Homestead Spring	0	0	WGS	GF070600GSMH20	F	Field Duplicate	7/9/2007	-	-	x	-	-	-	-	x	-	x	-	-
Homestead Spring	0	0	WGS	SU070600GSMH01	UF	-	7/9/2007	-	-	-	-	-	x	-	-	-	-	-	-
Homestead Spring	0	0	WGS	SU070600GSMH20	UF	Field Duplicate	7/9/2007	-	-	-	-	-	x	-	-	-	-	-	-
Homestead Spring	0	0	WGS	GU070800GSMH01	UF	-	9/5/2007	-	-	x	-	x	x	-	x	x	x	x	x
Homestead Spring	0	0	WGS	GU070800GSMH20	UF	Field Duplicate	9/5/2007	-	-	x	-	x	x	-	x	x	x	x	x
Homestead Spring	0	0	WGS	UU070800GSMH01	UF	-	9/5/2007	-	-	-	-	-	-	-	-	-	x	-	-
Homestead Spring	0	0	WGS	UU070800GSMH20	UF	Field Duplicate	9/5/2007	-	-	-	-	-	-	-	-	-	x	-	-
Homestead Spring	0	0	WGS	GF070800GSMH01	F	-	9/5/2007	-	-	x	-	-	-	-	x	-	x	-	-
Homestead Spring	0	0	WGS	GF070800GSMH20	F	Field Duplicate	9/5/2007	-	-	x	-	-	-	-	x	-	x	-	-
Homestead Spring	0	0	WGS	SU070800GSMH01	UF	-	9/5/2007	-	-	-	-	-	x	-	-	-	-	-	-
Homestead Spring	0	0	WGS	SU070800GSMH20	UF	Field Duplicate	9/5/2007	-	-	-	-	-	x	-	-	-	-	-	-
Homestead Spring	0	0	WGS	CAPA-08-9232	UF	-	12/3/2007	-	-	x	-	-	x	-	x	x	x	x	x
Homestead Spring	0	0	WGS	CAPA-08-9234	UF	Field	12/3/2007	-	-	x	-	-	x	-	x	x	x	x	x

Table C-2.0-3 (continued)

Location ID	Top Depth (ft)	Bottom Depth (ft)	Media Description	Sample ID	Field Prep	Field QC Type	Collection Date	DIOX/FUR	DRO	GENINORG	GRO	Herb	HEXP	Isotope	Metals	Pest/PCB	RAD	SVOA	VOA
						Duplicate													
Homestead Spring	0	0	WGS	CAPA-08-9231	F	-	12/3/2007	-	-	x	-	-	-	-	x	-	x	-	-
Homestead Spring	0	0	WGS	CAPA-08-9235	F	Field Duplicate	12/3/2007	-	-	x	-	-	-	-	x	-	x	-	-
Homestead Spring	0	0	WGS	CAPA-08-10962	F	-	3/11/2008	-	-	x	-	-	-	-	x	-	x	-	-
Homestead Spring	0	0	WGA	CAPA-08-13051	UF	-	6/24/2008	-	-	x	-	-	x	-	x	x	x	-	x
Homestead Spring	0	0	WGA	CAPA-08-13054	UF	Field Duplicate	6/24/2008	-	-	x	-	-	x	-	x	x	x	x	x
Homestead Spring	0	0	WGA	CAPA-08-13050	F	-	6/24/2008	-	-	x	-	-	-	-	x	-	x	-	-
Homestead Spring	0	0	WGA	CAPA-08-13053	F	Field Duplicate	6/24/2008	-	-	x	-	-	-	-	x	-	x	-	-
Homestead Spring	n/p	n/p	WGS	CAPA-08-10961	UF	-	3/11/2008	-	-	x	-	-	x	-	x	x	x	x	x
Kieling Spring	0	0	WGS	GU04070GSLK01	UF	-	9/9/2004	-	-	x	-	-	x	-	x	x	x	x	x
Kieling Spring	0	0	WGS	GF04070GSLK01	F	-	9/9/2004	-	-	x	-	-	-	-	x	-	x	-	-
Kieling Spring	0	0	WGS	GU05060GSLK01	UF	-	6/20/2005	-	-	x	-	-	x	-	x	x	x	x	x
Kieling Spring	0	0	WGS	GF05060GSLK01	F	-	6/20/2005	-	-	x	-	-	-	-	x	-	x	-	-
Kieling Spring	0	0	WGS	GU060800GSLK01	UF	-	8/30/2006	-	-	x	-	x	x	-	x	x	x	x	x
Kieling Spring	0	0	WGS	UU060800GSLK01	UF	-	8/30/2006	-	-	-	-	-	-	-	-	-	x	-	-

Table C-2.0-3 (continued)

Location ID	Top Depth (ft)	Bottom Depth (ft)	Media Description	Sample ID	Field Prep	Field QC Type	Collection Date	DIOX/FUR	DRO	GENINORG	GRO	Herb	HEXP	Isotope	Metals	Pest/PCB	RAD	SVOA	VOA
Kieling Spring	0	0	WGS	GF060800GSLK01	F	-	8/30/2006	-	-	x	-	-	-	-	x	-	x	-	-
Kieling Spring	0	0	WGS	SU060800GSLK01	UF	-	8/30/2006	-	-	-	-	-	x	-	-	-	-	-	-
Kieling Spring	0	0	WGS	GU060800GSLK01	F	-	8/30/2006	-	-	x	-	-	-	-	-	-	-	-	-
Kieling Spring	0	0	WGS	GU061200GSLK01	UF	-	12/7/2006	-	-	x	-	-	x	-	x	x	x	x	x
Kieling Spring	0	0	WGS	UU061200GSLK01	UF	-	12/7/2006	-	-	-	-	-	-	-	-	-	x	-	-
Kieling Spring	0	0	WGS	GF061200GSLK01	F	-	12/7/2006	-	-	x	-	-	-	-	x	-	x	-	-
Kieling Spring	0	0	WGS	SU061200GSLK01	UF	-	12/7/2006	-	-	-	-	-	x	-	-	-	-	-	-
Kieling Spring	0	0	WGS	GU061200GSLK01	F	-	12/7/2006	-	-	x	-	-	-	-	-	-	-	-	-
Kieling Spring	0	0	WGS	GU070300GSLK01	UF	-	3/26/2007	-	-	x	-	-	x	-	x	x	x	x	x
Kieling Spring	0	0	WGS	UU070300GSLK01	UF	-	3/26/2007	-	-	-	-	-	-	-	-	-	x	-	-
Kieling Spring	0	0	WGS	GF070300GSLK01	F	-	3/26/2007	-	-	x	-	-	-	-	x	-	x	-	-
Kieling Spring	0	0	WGS	SU070300GSLK01	UF	-	3/26/2007	-	-	-	-	-	x	-	-	-	-	-	-
Kieling Spring	0	0	WGS	GU070600GSLK01	UF	-	7/10/2007	-	-	x	-	-	x	-	x	x	x	x	x
Kieling Spring	0	0	WGS	UU070600GSLK01	UF	-	7/10/2007	-	-	-	-	-	-	-	-	-	x	-	-
Kieling Spring	0	0	WGS	GF070600GSLK01	F	-	7/10/2007	-	-	x	-	-	-	-	x	-	x	-	-
Kieling Spring	0	0	WGS	SU070600GSLK01	UF	-	7/10/2007	-	-	-	-	-	x	-	-	-	-	-	-

Table C-2.0-3 (continued)

Location ID	Top Depth (ft)	Bottom Depth (ft)	Media Description	Sample ID	Field Prep	Field QC Type	Collection Date	DIOX/FUR	DRO	GENINORG	GRO	Herb	HEXP	Isotope	Metals	Pest/PCB	RAD	SVOA	VOA
Kieling Spring	0	0	WGS	GU070800GSLK01	UF	-	9/4/2007	-	-	x	-	x	x	-	x	x	x	x	x
Kieling Spring	0	0	WGS	UU070800GSLK01	UF	-	9/4/2007	-	-	-	-	-	-	-	-	-	x	-	-
Kieling Spring	0	0	WGS	GF070800GSLK01	F	-	9/4/2007	-	-	x	-	-	-	-	x	-	x	-	-
Kieling Spring	0	0	WGS	SU070800GSLK01	UF	-	9/4/2007	-	-	-	-	-	x	-	-	-	-	-	-
Kieling Spring	0	0	WGS	CAPA-08-9210	UF	-	12/3/2007	-	-	x	-	-	x	-	x	x	x	x	x
Kieling Spring	0	0	WGS	CAPA-08-9211	F	-	12/3/2007	-	-	x	-	-	-	-	x	-	x	-	-
Kieling Spring	0	0	WGS	CAPA-08-10981	UF	-	3/11/2008	-	-	x	-	-	x	-	x	x	x	x	x
Kieling Spring	0	0	WGA	CAPA-08-13062	UF	-	6/10/2008	-	-	x	-	-	x	-	x	x	x	x	x
Kieling Spring	0	0	WGA	CAPA-08-13063	F	-	6/10/2008	-	-	x	-	-	-	-	x	-	x	-	-
Kieling Spring	n/p	n/p	WGS	CAPA-08-10979	F	-	3/11/2008	-	-	x	-	-	-	-	x	-	x	-	-
PC Spring	0	0	WGS	GU04070GSCP01	UF	-	9/16/2004	-	-	x	-	-	x	-	x	x	x	x	x
PC Spring	0	0	WGS	GF04070GSCP01	F	-	9/16/2004	-	-	x	-	-	-	-	x	-	x	-	-
PC Spring	0	0	WGS	GU05060GSCP01	UF	-	6/21/2005	-	-	x	-	-	x	-	x	x	x	x	x
PC Spring	0	0	WGS	GF05060GSCP01	F	-	6/21/2005	-	-	x	-	-	-	-	x	-	x	-	-
PC Spring	0	0	WGS	GU060800GSCP01	UF	-	8/31/2006	-	-	x	-	x	x	-	x	x	x	x	x
PC Spring	0	0	WGS	UU060800GSCP01	UF	-	8/31/2006	-	-	-	-	-	-	-	-	-	x	-	-

Table C-2.0-3 (continued)

Location ID	Top Depth (ft)	Bottom Depth (ft)	Media Description	Sample ID	Field Prep	Field QC Type	Collection Date	DIOX/FUR	DRO	GENINORG	GRO	Herb	HEXP	Isotope	Metals	Pest/PCB	RAD	SVOA	VOA
PC Spring	0	0	WGS	GF060800GSCP01	F	-	8/31/2006	-	-	x	-	-	-	-	x	-	x	-	-
PC Spring	0	0	WGS	SU060800GSCP01	UF	-	8/31/2006	-	-	-	-	-	x	-	-	-	-	-	-
PC Spring	0	0	WGS	GU060800GSCP01	F	-	8/31/2006	-	-	x	-	-	-	-	-	-	-	-	-
PC Spring	0	0	WGS	GU061200GSCP01	UF	-	12/14/2006	-	-	x	-	-	x	-	x	x	x	x	x
PC Spring	0	0	WGS	GF061200GSCP01	F	-	12/14/2006	-	-	x	-	-	-	-	x	-	x	-	-
PC Spring	0	0	WGS	SU061200GSCP01	UF	-	12/14/2006	-	-	-	-	-	x	-	-	-	-	-	-
PC Spring	0	0	WGS	GU061200GSCP01	F	-	12/14/2006	-	-	x	-	-	-	-	-	-	-	-	-
PC Spring	0	0	WGS	GU070300GSCP01	UF	-	3/28/2007	-	-	x	-	-	x	-	x	x	x	x	x
PC Spring	0	0	WGS	UU070300GSCP01	UF	-	3/28/2007	-	-	-	-	-	-	-	-	-	x	-	-
PC Spring	0	0	WGS	GF070300GSCP01	F	-	3/28/2007	-	-	x	-	-	-	-	x	-	x	-	-
PC Spring	0	0	WGS	SU070300GSCP01	UF	-	3/28/2007	-	-	-	-	-	x	-	-	-	-	-	-
PC Spring	0	0	WGS	GU070600GSCP01	UF	-	7/11/2007	-	-	x	-	-	x	-	x	x	x	x	x
PC Spring	0	0	WGS	UU070600GSCP01	UF	-	7/11/2007	-	-	-	-	-	-	-	-	-	x	-	-
PC Spring	0	0	WGS	GF070600GSCP01	F	-	7/11/2007	-	-	x	-	-	-	-	x	-	x	-	-
PC Spring	0	0	WGS	SU070600GSCP01	UF	-	7/11/2007	-	-	-	-	-	x	-	-	-	-	-	-
PC Spring	0	0	WGS	GU070900GSCP01	UF	-	9/19/2007	-	-	x	-	x	x	-	x	x	x	x	x

Table C-2.0-3 (continued)

Location ID	Top Depth (ft)	Bottom Depth (ft)	Media Description	Sample ID	Field Prep	Field QC Type	Collection Date	DIOX/FUR	DRO	GENINORG	GRO	Herb	HEXP	Isotope	Metals	Pest/PCB	RAD	SVOA	VOA
PC Spring	0	0	WGS	UU070900GSCP01	UF	-	9/19/2007	-	-	-	-	-	-	-	-	-	X	-	-
PC Spring	0	0	WGS	GF070900GSCP01	F	-	9/19/2007	-	-	X	-	-	-	-	X	-	X	-	-
PC Spring	0	0	WGS	SU070900GSCP01	UF	-	9/19/2007	-	-	-	-	-	X	-	-	-	-	-	-
PC Spring	0	0	WGS	CAPA-08-9294	UF	-	12/18/2007	-	-	X	-	-	X	-	X	X	X	X	X
PC Spring	0	0	WGS	CAPA-08-9293	F	-	12/18/2007	-	-	X	-	-	-	-	X	-	X	-	-
PC Spring	0	0	WGS	CAPA-08-10958	UF	-	3/19/2008	-	-	X	-	-	X	-	X	X	X	X	X
PC Spring	0	0	WGS	CAPA-08-10960	F	-	3/19/2008	-	-	X	-	-	-	-	X	-	X	-	-
PC Spring	0	0	WGA	CAPA-08-13048	UF	-	6/13/2008	-	-	X	-	-	X	-	X	X	X	X	X
PC Spring	0	0	WGA	CAPA-08-13047	F	-	6/13/2008	-	-	X	-	-	-	-	X	-	X	-	-
PCAO-5	14.7	24.7	WGA	CAPA-08-13119	UF	-	6/9/2008	-	-	X	-	X	X	-	X	X	X	X	X
PCAO-5	14.7	24.7	WGA	CAPA-08-13224	UF	Field Duplicate	6/9/2008	-	-	-	-	-	-	-	-	-	-	X	X
PCAO-5	14.7	24.7	WGA	CAPA-08-13120	F	-	6/9/2008	-	-	X	-	-	-	-	X	-	X	-	-
PCAO-7a	9.7	19.7	WGA	CAPA-08-13221	F	-	6/22/2008	-	-	X	-	-	-	-	X	-	X	-	-
PCAO-7a	9.7	19.7	WGA	CAPA-08-13223	UF	-	6/22/2008	-	-	X	-	X	X	-	X	X	X	X	X
PCAO-7b2	0	0	WGA	CAPA-08-13117	UF	-	6/25/2008	-	-	X	-	X	X	-	X	X	X	X	X
PCAO-7b2	0	0	WGA	CAPA-08-13116	F	-	6/25/2008	-	-	X	-	-	-	-	X	-	X	-	-

Table C-2.0-3 (continued)

Location ID	Top Depth (ft)	Bottom Depth (ft)	Media Description	Sample ID	Field Prep	Field QC Type	Collection Date	DIOX/FUR	DRO	GENINORG	GRO	Herb	HEXP	Isotope	Metals	Pest/PCB	RAD	SVOA	VOA
PCAO-7c	9.7	19.7	WGA	CAPA-08-13123	UF	-	6/22/2008	-	-	x	-	x	x	-	x	x	x	x	x
PCAO-7c	9.7	19.7	WGA	CAPA-08-13121	F	-	6/22/2008	-	-	x	-	-	-	-	x	-	x	-	-
PCAO-8	9.7	19.7	WGA	CAPA-08-13131	UF	-	6/24/2008	-	-	x	-	-	x	-	x	-	-	-	x
PCAO-8	9.7	19.7	WGA	CAPA-08-13130	F	-	6/24/2008	-	-	x	-	-	-	-	x	-	-	-	-
PCAO-9	6	16	WGA	CAPA-08-13386	UF	-	6/25/2008	-	-	x	-	x	x	-	x	x	x	x	x
PCAO-9	6	16	WGA	CAPA-08-13385	F	-	6/25/2008	-	-	x	-	-	-	-	x	-	x	-	-
PCO-1	4	12	WGA	8506WGG1CP	UF	-	6/11/1985	-	-	x	-	-	-	-	x	-	x	-	-
PCO-1	4	12	WGA	8506WGG1CP	F	-	6/11/1985	-	-	x	-	-	-	-	x	-	-	-	-
PCO-1	4	12	WGA	8603WGG1CP	UF	-	3/1/1986	-	-	x	-	-	-	-	x	-	x	-	-
PCO-1	4	12	WGA	8603WGG1CP	F	-	3/1/1986	-	-	x	-	-	-	-	x	-	-	-	-
PCO-1	4	12	WGA	8606WGG1CP	UF	-	6/1/1986	-	-	x	-	-	-	-	x	-	x	-	-
PCO-1	4	12	WGA	8606WGG1CP	F	-	6/1/1986	-	-	x	-	-	-	-	x	-	-	-	-
PCO-1	4	12	WGA	8710WGG1CP	UF	-	10/26/1987	-	-	x	-	-	-	-	x	-	x	-	-
PCO-1	4	12	WGA	8710WGG1CP	F	-	10/26/1987	-	-	x	-	-	-	-	x	-	-	-	-
PCO-1	4	12	WGA	8804WGG1CP	UF	-	4/4/1988	-	-	x	-	-	-	-	x	-	x	-	-
PCO-1	4	12	WGA	8804WGG1CP	F	-	4/4/1988	-	-	x	-	-	-	-	x	-	-	-	-

Table C-2.0-3 (continued)

Location ID	Top Depth (ft)	Bottom Depth (ft)	Media Description	Sample ID	Field Prep	Field QC Type	Collection Date	DIOX/FUR	DRO	GENINORG	GRO	Herb	HEXP	Isotope	Metals	Pest/PCB	RAD	SVOA	VOA
PCO-1	4	12	WGA	8903WGG1CP	UF	-	3/27/1989	-	-	x	-	-	-	-	x	-	x	-	-
PCO-1	4	12	WGA	8903WGG1CP	F	-	3/27/1989	-	-	x	-	-	-	-	x	-	-	-	-
PCO-1	4	12	WGA	9004WGG1CP	UF	-	4/17/1990	-	-	x	-	-	-	-	x	-	x	-	-
PCO-1	4	12	WGA	9004WGG1CP	F	-	4/17/1990	-	-	x	-	-	-	-	x	-	-	-	-
PCO-1	4	12	WGA	9105WGG1CP	UF	-	5/29/1991	-	-	x	-	-	-	-	x	-	x	-	-
PCO-1	4	12	WGA	9105WGG1CP	F	-	5/29/1991	-	-	x	-	-	-	-	x	-	-	-	-
PCO-1	4	12	WGA	9209WGG1CP	UF	-	9/1/1992	-	-	x	-	-	-	-	x	-	x	-	-
PCO-1	4	12	WGA	9209WGG1CP	F	-	9/1/1992	-	-	x	-	-	-	-	x	-	-	-	-
PCO-1	4	12	WGA	9306WGG1CP	UF	-	6/7/1993	-	-	-	-	-	-	-	x	-	x	-	-
PCO-1	4	12	WGA	9306WGG1CP	F	-	6/7/1993	-	-	x	-	-	-	-	x	-	-	-	-
PCO-1	4	12	WGA	9406WGG1CP	UF	-	6/22/1994	-	-	-	-	-	-	-	x	-	x	-	-
PCO-1	4	12	WGA	9406WGG1CP	F	-	6/22/1994	-	-	x	-	-	-	-	x	-	-	-	-
PCO-1	4	12	WGA	MNM95060044	UF	-	5/20/1995	-	-	x	-	-	-	-	x	-	x	-	-
PCO-1	4	12	WGA	MNM95060044	F	-	5/20/1995	-	-	x	-	-	-	-	-	-	-	-	-
PCO-1	4	12	WGA	MM96071G1CP	UF	-	7/30/1996	-	-	x	-	-	-	-	x	-	x	-	-
PCO-1	4	12	WGA	MM96071G1CP	F	-	7/30/1996	-	-	x	-	-	-	-	-	-	-	-	-

Table C-2.0-3 (continued)

Location ID	Top Depth (ft)	Bottom Depth (ft)	Media Description	Sample ID	Field Prep	Field QC Type	Collection Date	DIOX/FUR	DRO	GENINORG	GRO	Herb	HEXP	Isotope	Metals	Pest/PCB	RAD	SVOA	VOA
PCO-1	4	12	WGA	MM97061G1CP	UF	-	6/16/1997	-	-	x	-	-	-	-	x	x	x	x	x
PCO-1	4	12	WGA	9706WGG1CP	UF	-	6/16/1997	-	-	-	-	-	-	-	x	-	x	-	-
PCO-1	4	12	WGA	MM97061G1CP	F	-	6/16/1997	-	-	x	-	-	-	-	-	-	-	-	-
PCO-1	4	12	WGA	9706WGG1CP	F	-	6/16/1997	-	-	x	-	-	-	-	-	-	-	-	-
PCO-1	4	12	WGA	MM98041G1CP	UF	-	4/30/1998	-	-	x	-	-	x	-	x	-	x	-	-
PCO-1	4	12	WGA	MM98041G1CP	F	-	4/30/1998	-	-	x	-	-	-	-	x	-	x	-	-
PCO-1	4	12	WGA	MF98041G1CP	F	-	4/30/1998	-	-	x	-	-	-	-	x	-	-	-	-
PCO-1	4	12	WGA	MM99031G1CP	UF	-	3/26/1999	-	-	x	-	-	x	-	x	-	x	-	-
PCO-1	4	12	WGA	MM99031G1CP	F	-	3/26/1999	-	-	x	-	-	-	-	x	-	-	-	-
PCO-1	4	12	WGA	MF99031G1CP	F	-	3/26/1999	-	-	x	-	-	-	-	x	-	-	-	-
PCO-1	4	12	WGA	MM99121G1CP	UF	-	12/9/1999	-	-	-	-	-	-	-	-	-	x	-	-
PCO-1	4	12	WGA	GU01041G1CP	UF	-	4/10/2001	-	-	x	-	-	x	-	x	x	x	x	x
PCO-1	4	12	WGA	GF01041G1CP	F	-	4/10/2001	-	-	x	-	-	-	-	x	-	x	-	-
PCO-1	4	12	WGA	GU01042G1CP	UF	-	4/10/2001	-	-	x	-	-	x	-	x	x	x	x	x
PCO-1	4	12	WGA	GF01042G1CP	F	Field Duplicate	4/10/2001	-	-	x	-	-	-	-	x	-	x	-	-
PCO-1	4	12	WGA	GU05060G1CP01	UF	-	8/24/2005	-	-	x	-	-	x	-	x	x	x	x	x

Table C-2.0-3 (continued)

Location ID	Top Depth (ft)	Bottom Depth (ft)	Media Description	Sample ID	Field Prep	Field QC Type	Collection Date	DIOX/FUR	DRO	GENINORG	GRO	Herb	HEXP	Isotope	Metals	Pest/PCB	RAD	SVOA	VOA
PCO-1	4	12	WGA	GF05060G1CP01	F	-	8/24/2005	-	-	x	-	-	-	-	x	-	x	-	-
PCO-2	1.5	9.5	WGA	8506WGG2CP	UF	-	6/11/1985	-	-	x	-	-	-	-	x	-	x	-	-
PCO-2	1.5	9.5	WGA	8506WGG2CP	F	-	6/11/1985	-	-	x	-	-	-	-	x	-	-	-	-
PCO-2	1.5	9.5	WGA	8606WGG2CP	UF	-	6/1/1986	-	-	x	-	-	-	-	x	-	x	-	-
PCO-2	1.5	9.5	WGA	8606WGG2CP	F	-	6/1/1986	-	-	x	-	-	-	-	x	-	-	-	-
PCO-2	1.5	9.5	WGA	8710WGG2CP	UF	-	10/26/1987	-	-	x	-	-	-	-	x	-	x	-	-
PCO-2	1.5	9.5	WGA	8710WGG2CP	F	-	10/26/1987	-	-	x	-	-	-	-	x	-	-	-	-
PCO-2	1.5	9.5	WGA	8804WGG2CP	UF	-	4/4/1988	-	-	x	-	-	-	-	x	-	x	-	-
PCO-2	1.5	9.5	WGA	8804WGG2CP	F	-	4/4/1988	-	-	x	-	-	-	-	x	-	-	-	-
PCO-2	1.5	9.5	WGA	8903WGG2CP	UF	-	3/27/1989	-	-	x	-	-	-	-	x	-	x	-	-
PCO-2	1.5	9.5	WGA	8903WGG2CP	F	-	3/27/1989	-	-	x	-	-	-	-	x	-	-	-	-
PCO-2	1.5	9.5	WGA	9004WGG2CP	UF	-	4/17/1990	-	-	x	-	-	-	-	x	-	x	-	-
PCO-2	1.5	9.5	WGA	9004WGG2CP	F	-	4/17/1990	-	-	x	-	-	-	-	x	-	-	-	-
PCO-2	1.5	9.5	WGA	9105WGG2CP	UF	-	5/29/1991	-	-	x	-	-	-	-	x	-	x	-	-
PCO-2	1.5	9.5	WGA	9105WGG2CP	F	-	5/29/1991	-	-	x	-	-	-	-	x	-	-	-	-
PCO-2	1.5	9.5	WGA	9209WGG2CP	UF	-	9/1/1992	-	-	x	-	-	-	-	x	-	x	-	-

Table C-2.0-3 (continued)

Location ID	Top Depth (ft)	Bottom Depth (ft)	Media Description	Sample ID	Field Prep	Field QC Type	Collection Date	DIOX/FUR	DRO	GENINORG	GRO	Herb	HEXP	Isotope	Metals	Pest/PCB	RAD	SVOA	VOA
PCO-2	1.5	9.5	WGA	9209WGG2CP	F	-	9/1/1992	-	-	x	-	-	-	-	x	-	-	-	-
PCO-2	1.5	9.5	WGA	9306WGG2CP	UF	-	6/7/1993	-	-	-	-	-	-	-	x	-	x	-	-
PCO-2	1.5	9.5	WGA	9306WGG2CP	F	-	6/7/1993	-	-	x	-	-	-	-	x	-	-	-	-
PCO-2	1.5	9.5	WGA	9406WGG2CP	UF	-	6/22/1994	-	-	-	-	-	-	-	x	-	x	-	-
PCO-2	1.5	9.5	WGA	9406WGG2CP	F	-	6/22/1994	-	-	x	-	-	-	-	x	-	-	-	-
PCO-2	1.5	9.5	WGA	MNM95060045	UF	-	5/20/1995	-	-	x	-	-	-	-	x	-	x	-	-
PCO-2	1.5	9.5	WGA	MNM95060045	F	-	5/20/1995	-	-	x	-	-	-	-	-	-	-	-	-
PCO-2	1.5	9.5	WGA	GU05070G2CP01	UF	-	8/30/2005	-	-	x	-	-	x	-	x	x	x	x	x
PCO-2	1.5	9.5	WGA	GF05070G2CP01	F	-	8/30/2005	-	-	x	-	-	-	-	x	-	x	-	-
PCO-2	1.5	9.5	WGA	GF070300G2CP01	F	-	3/20/2007	-	-	x	-	-	-	-	x	-	-	-	-
PCO-2	1.5	9.5	WGA	GU070600G2CP01	UF	-	6/25/2007	-	-	x	-	-	x	-	x	x	x	x	x
PCO-2	1.5	9.5	WGA	UU070600G2CP01	UF	-	6/25/2007	-	-	-	-	-	-	-	-	-	x	-	-
PCO-2	1.5	9.5	WGA	GF070600G2CP01	F	-	6/25/2007	-	-	x	-	-	-	-	x	-	x	-	-
PCO-2	1.5	9.5	WGA	SU070600G2CP01	UF	-	6/25/2007	-	-	-	-	-	x	-	-	-	-	-	-
PCO-2	1.5	9.5	WGA	GU070900G2CP01	UF	-	9/11/2007	-	-	x	-	x	x	-	x	x	x	x	x
PCO-2	1.5	9.5	WGA	GF070900G2CP01	F	-	9/11/2007	-	-	x	-	-	-	-	x	-	x	-	-

Table C-2.0-3 (continued)

Location ID	Top Depth (ft)	Bottom Depth (ft)	Media Description	Sample ID	Field Prep	Field QC Type	Collection Date	DIOX/FUR	DRO	GENINORG	GRO	Herb	HEXP	Isotope	Metals	Pest/PCB	RAD	SVOA	VOA
PCO-2	1.5	9.5	WGA	SU070900G2CP01	UF	-	9/11/2007	-	-	-	-	-	X	-	-	-	-	-	-
PCO-2	1.5	9.5	WGA	CAPA-08-9302	UF	-	12/6/2007	-	-	X	-	X	X	-	X	X	X	X	X
PCO-2	1.5	9.5	WGA	CAPA-08-9301	F	-	12/6/2007	-	-	X	-	-	-	-	X	-	X	-	-
PCO-2	1.5	9.5	WGA	CAPA-08-13105	UF	-	6/10/2008	-	-	X	-	-	X	-	X	X	X	X	X
PCO-2	1.5	9.5	WGA	CAPA-08-13106	UF	Field Duplicate	6/10/2008	-	-	X	-	-	X	-	X	X	X	X	X
PCO-2	1.5	9.5	WGA	CAPA-08-13104	F	-	6/10/2008	-	-	X	-	-	-	-	X	-	X	-	-
PCO-2	1.5	9.5	WGA	CAPA-08-13102	F	Field Duplicate	6/10/2008	-	-	X	-	-	-	-	X	-	X	-	-
PCO-2	n/p	n/p	WGA	CAPA-08-10944	UF	-	3/7/2008	-	-	X	-	-	X	-	X	X	X	X	X
PCO-2	n/p	n/p	WGA	CAPA-08-10946	F	-	3/7/2008	-	-	X	-	-	-	-	X	-	X	-	-
PCO-3	5.7	17.7	WGA	8506WGG3CP	UF	-	6/11/1985	-	-	X	-	-	-	-	X	-	X	-	-
PCO-3	5.7	17.7	WGA	8506WGG3CP	F	-	6/11/1985	-	-	X	-	-	-	-	X	-	-	-	-
PCO-3	5.7	17.7	WGA	8603WGG3CP	UF	-	3/1/1986	-	-	X	-	-	-	-	X	-	X	-	-
PCO-3	5.7	17.7	WGA	8603WGG3CP	F	-	3/1/1986	-	-	X	-	-	-	-	X	-	-	-	-
PCO-3	5.7	17.7	WGA	8606WGG3CP	UF	-	6/1/1986	-	-	X	-	-	-	-	X	-	X	-	-
PCO-3	5.7	17.7	WGA	8606WGG3CP	F	-	6/1/1986	-	-	X	-	-	-	-	X	-	-	-	-

Table C-2.0-3 (continued)

Location ID	Top Depth (ft)	Bottom Depth (ft)	Media Description	Sample ID	Field Prep	Field QC Type	Collection Date	DIOX/FUR	DRO	GENINORG	GRO	Herb	HEXP	Isotope	Metals	Pest/PCB	RAD	SVOA	VOA
PCO-3	5.7	17.7	WGA	8710WGG3CP	UF	-	10/26/1987	-	-	x	-	-	-	-	x	-	x	-	-
PCO-3	5.7	17.7	WGA	8710WGG3CP	F	-	10/26/1987	-	-	x	-	-	-	-	x	-	-	-	-
PCO-3	5.7	17.7	WGA	8804WGG3CP	UF	-	4/4/1988	-	-	x	-	-	-	-	x	-	x	-	-
PCO-3	5.7	17.7	WGA	8804WGG3CP	F	-	4/4/1988	-	-	x	-	-	-	-	x	-	-	-	-
PCO-3	5.7	17.7	WGA	8903WGG3CP	UF	-	3/27/1989	-	-	x	-	-	-	-	x	-	x	-	-
PCO-3	5.7	17.7	WGA	8903WGG3CP	F	-	3/27/1989	-	-	x	-	-	-	-	x	-	-	-	-
PCO-3	5.7	17.7	WGA	9004WGG3CP	UF	-	4/17/1990	-	-	x	-	-	-	-	x	-	x	-	-
PCO-3	5.7	17.7	WGA	9004WGG3CP	F	-	4/17/1990	-	-	x	-	-	-	-	x	-	-	-	-
PCO-3	5.7	17.7	WGA	9105WGG3CP	UF	-	5/29/1991	-	-	x	-	-	-	-	x	-	x	-	-
PCO-3	5.7	17.7	WGA	9105WGG3CP	F	-	5/29/1991	-	-	x	-	-	-	-	x	-	-	-	-
PCO-3	5.7	17.7	WGA	9209WGG3CP	UF	-	9/1/1992	-	-	x	-	-	-	-	x	-	x	-	-
PCO-3	5.7	17.7	WGA	9209WGG3CP	F	-	9/1/1992	-	-	x	-	-	-	-	x	-	-	-	-
PCO-3	5.7	17.7	WGA	9306WGG3CP	UF	-	6/7/1993	-	-	-	-	-	-	-	x	-	x	-	-
PCO-3	5.7	17.7	WGA	9306WGG3CP	F	-	6/7/1993	-	-	x	-	-	-	-	x	-	-	-	-
PCO-3	5.7	17.7	WGA	WG9408122411	UF	-	8/12/1994	-	-	-	-	-	-	-	x	-	x	-	-
PCO-3	5.7	17.7	WGA	WG9408122411	F	-	8/12/1994	-	-	x	-	-	-	-	x	-	-	-	-

Table C-2.0-3 (continued)

Location ID	Top Depth (ft)	Bottom Depth (ft)	Media Description	Sample ID	Field Prep	Field QC Type	Collection Date	DIOX/FUR	DRO	GENINORG	GRO	Herb	HEXP	Isotope	Metals	Pest/PCB	RAD	SVOA	VOA
PCO-3	5.7	17.7	WGA	WG9408152411	UF	-	8/15/1994	-	-	-	-	-	-	-	X	-	X	-	-
PCO-3	5.7	17.7	WGA	MNM95060046	UF	-	5/20/1995	-	-	X	-	-	X	-	X	X	X	X	X
PCO-3	5.7	17.7	WGA	MNM95060046	F	-	5/20/1995	-	-	X	-	-	-	-	-	-	-	-	-
PCO-3	5.7	17.7	WGA	9506WGG3CP	UF	-	6/20/1995	-	-	-	-	-	-	-	-	-	-	-	X
PCO-3	5.7	17.7	WGA	9506WGG3CP	F	-	6/20/1995	-	-	X	-	-	-	-	X	-	X	-	-
PCO-3	5.7	17.7	WGA	MM98051G3CP	UF	-	5/13/1998	-	-	X	-	-	X	-	X	X	X	X	X
PCO-3	5.7	17.7	WGA	MM98051G3CP	F	-	5/13/1998	-	-	X	-	-	-	-	X	-	-	-	-
PCO-3	5.7	17.7	WGA	MF98051G3CP	F	-	5/13/1998	-	-	X	-	-	-	-	X	-	-	-	-
PCO-3	5.7	17.7	WGA	GU01041G3CP	UF	-	4/10/2001	-	-	X	-	-	X	-	X	X	X	X	X
PCO-3	5.7	17.7	WGA	GF01041G3CP	F	-	4/10/2001	-	-	X	-	-	-	-	X	-	X	-	-
PCO-3	5.7	17.7	WGA	GU05080G3CP01	UF	-	8/23/2005	-	-	X	-	-	X	-	X	X	X	X	X
PCO-3	5.7	17.7	WGA	GF05080G3CP01	F	-	8/23/2005	-	-	X	-	-	-	-	X	-	-	-	-
PCO-3	5.7	17.7	WGA	GU061200G3CP02	UF	-	12/13/2006	-	-	X	-	-	X	-	X	X	X	X	X
PCO-3	5.7	17.7	WGA	GF061200G3CP02	F	-	12/13/2006	-	-	X	-	-	-	-	X	-	X	-	-
PCO-3	5.7	17.7	WGA	SU061200G3CP02	UF	-	12/13/2006	-	-	-	-	-	X	-	-	-	-	-	-
PCO-3	5.7	17.7	WGA	GU061200G3CP02	F	-	12/13/2006	-	-	X	-	-	-	-	-	-	-	-	-

Table C-2.0-3 (continued)

Location ID	Top Depth (ft)	Bottom Depth (ft)	Media Description	Sample ID	Field Prep	Field QC Type	Collection Date	DIOX/FUR	DRO	GENINORG	GRO	Herb	HEXP	Isotope	Metals	Pest/PCB	RAD	SVOA	VOA
PCO-3	5.7	17.7	WGA	GU070300G3CP01	UF	-	4/4/2007	-	-	x	-	-	x	-	x	x	x	x	x
PCO-3	5.7	17.7	WGA	UU070300G3CP01	UF	-	4/4/2007	-	-	-	-	-	-	-	-	-	x	-	-
PCO-3	5.7	17.7	WGA	GF070300G3CP01	F	-	4/4/2007	-	-	x	-	-	-	-	x	-	x	-	-
PCO-3	5.7	17.7	WGA	SU070300G3CP01	UF	-	4/4/2007	-	-	-	-	-	x	-	-	-	-	-	-
PCO-3	5.7	17.7	WGA	GU070900G3CP01	UF	-	9/11/2007	-	-	x	-	x	x	-	x	x	x	x	x
PCO-3	5.7	17.7	WGA	UU070900G3CP01	UF	-	9/11/2007	-	-	-	-	-	-	-	-	-	x	-	-
PCO-3	5.7	17.7	WGA	GF070900G3CP01	F	-	9/11/2007	-	-	x	-	-	-	-	x	-	x	-	-
PCO-3	5.7	17.7	WGA	SU070900G3CP01	UF	-	9/11/2007	-	-	-	-	-	x	-	-	-	-	-	-
PCO-3	5.7	17.7	WGA	CAPA-08-9358	UF	-	12/7/2007	-	-	x	-	-	x	-	x	x	x	x	x
PCO-3	5.7	17.7	WGA	CAPA-08-9355	F	-	12/7/2007	-	-	x	-	-	-	-	x	-	x	-	-
PCO-3	n/p	n/p	WGA	CAPA-08-10947	UF	-	3/18/2008	-	-	x	-	-	x	-	x	x	x	x	x
PCO-3	n/p	n/p	WGA	CAPA-08-10949	F	-	3/18/2008	-	-	x	-	-	-	-	x	-	x	-	-
R-17	1057	1080	WGR	GU06090GR17101	UF	-	10/19/2006	-	x	x	-	x	x	-	x	x	x	x	x
R-17	1057	1080	WGR	UU06090GR17101	UF	-	10/19/2006	-	-	-	-	-	-	-	-	-	x	-	-
R-17	1057	1080	WGR	GF06090GR17101	F	-	10/19/2006	-	-	x	-	-	-	-	x	-	x	-	-
R-17	1057	1080	WGR	SF06090GR17101	F	-	10/19/2006	-	-	-	-	-	-	-	x	-	-	-	-

Table C-2.0-3 (continued)

Location ID	Top Depth (ft)	Bottom Depth (ft)	Media Description	Sample ID	Field Prep	Field QC Type	Collection Date	DIOX/FUR	DRO	GENINORG	GRO	Herb	HEXP	Isotope	Metals	Pest/PCB	RAD	SVOA	VOA
R-17	1057	1080	WGR	SU06090GR17101	UF	-	10/19/2006	-	-	-	-	-	X	-	-	-	-	-	-
R-17	1057	1080	WGR	GU07020GR17101	UF	-	2/22/2007	-	-	X	-	-	X	-	X	X	X	X	X
R-17	1057	1080	WGR	UU07020GR17101	UF	-	2/22/2007	-	-	-	-	-	-	-	-	-	X	-	-
R-17	1057	1080	WGR	GF07020GR17101	F	-	2/22/2007	-	-	X	-	-	-	-	X	-	X	-	-
R-17	1057	1080	WGR	SU07020GR17101	UF	-	2/22/2007	-	-	-	-	-	X	-	-	-	-	-	-
R-17	1057	1080	WGR	GU07040GR17101	UF	-	4/25/2007	-	-	X	-	-	X	-	X	X	X	X	X
R-17	1057	1080	WGR	GU07040GR17120	UF	Field Duplicate	4/25/2007	-	-	X	-	-	X	-	X	X	X	X	X
R-17	1057	1080	WGR	UU07040GR17101	UF	-	4/25/2007	-	-	-	-	-	-	-	-	-	X	-	-
R-17	1057	1080	WGR	UU07040GR17120	UF	Field Duplicate	4/25/2007	-	-	-	-	-	-	-	-	-	X	-	-
R-17	1057	1080	WGR	GF07040GR17101	F	-	4/25/2007	-	-	X	-	-	-	-	X	-	X	-	-
R-17	1057	1080	WGR	GF07040GR17120	F	Field Duplicate	4/25/2007	-	-	X	-	-	-	-	X	-	X	-	-
R-17	1057	1080	WGR	SU07040GR17101	UF	-	4/25/2007	-	-	-	-	-	X	-	-	-	-	-	-
R-17	1057	1080	WGR	SU07040GR17120	UF	Field Duplicate	4/25/2007	-	-	-	-	-	X	-	-	-	-	-	-
R-17	1057	1080	WGR	GU07060GR17101	UF	-	7/3/2007	-	-	X	-	-	X	-	X	X	X	X	X

Table C-2.0-3 (continued)

Location ID	Top Depth (ft)	Bottom Depth (ft)	Media Description	Sample ID	Field Prep	Field QC Type	Collection Date	DIOX/FUR	DRO	GENINORG	GRO	Herb	HEXP	Isotope	Metals	Pest/PCB	RAD	SVOA	VOA
R-17	1057	1080	WGR	UU07060GR17101	UF	-	7/3/2007	-	-	-	-	-	-	-	-	-	X	-	-
R-17	1057	1080	WGR	GF07060GR17101	F	-	7/3/2007	-	-	X	-	-	-	-	X	-	X	-	-
R-17	1057	1080	WGR	SU07060GR17101	UF	-	7/3/2007	-	-	-	-	-	X	-	-	-	-	-	-
R-17	1057	1080	WGR	GU07080GR17101	UF	-	9/18/2007	-	-	X	-	X	X	-	X	X	X	X	X
R-17	1057	1080	WGR	UU07080GR17101	UF	-	9/18/2007	-	-	-	-	-	-	-	-	-	X	-	-
R-17	1057	1080	WGR	GF07080GR17101	F	-	9/18/2007	-	-	X	-	-	-	-	X	-	X	-	-
R-17	1057	1080	WGR	SU07080GR17101	UF	-	9/18/2007	-	-	-	-	-	X	-	-	-	-	-	-
R-17	1057	1080	WGR	CAPA-08-9327	UF	-	12/5/2007	-	-	X	-	-	X	-	X	X	X	X	X
R-17	1057	1080	WGR	CAPA-08-9328	F	-	12/5/2007	-	-	X	-	-	-	-	X	-	X	-	-
R-17	1057	1080	WGR	CAPA-08-13161	UF	-	6/18/2008	-	-	X	-	-	X	-	X	X	X	X	X
R-17	1057	1080	WGR	CAPA-08-13160	F	-	6/18/2008	-	-	X	-	-	-	-	X	-	X	-	-
R-17	1124	1134	WGR	GU06090GR17201	UF	-	10/17/2006	-	X	X	-	X	X	-	X	X	X	X	X
R-17	1124	1134	WGR	UU06090GR17201	UF	-	10/17/2006	-	-	-	-	-	-	-	-	-	X	-	-
R-17	1124	1134	WGR	GF06090GR17201	F	-	10/17/2006	-	-	X	-	-	-	-	X	-	X	-	-
R-17	1124	1134	WGR	SF06090GR17201	F	-	10/17/2006	-	-	-	-	-	-	-	X	-	-	-	-
R-17	1124	1134	WGR	SU06090GR17201	UF	-	10/17/2006	-	-	-	-	-	X	-	-	-	-	-	-

Table C-2.0-3 (continued)

Location ID	Top Depth (ft)	Bottom Depth (ft)	Media Description	Sample ID	Field Prep	Field QC Type	Collection Date	DIOX/FUR	DRO	GENINORG	GRO	Herb	HEXP	Isotope	Metals	Pest/PCB	RAD	SVOA	VOA
R-17	1124	1134	WGR	GU07020GR17201	UF	-	2/22/2007	-	-	x	-	-	x	-	x	x	x	x	x
R-17	1124	1134	WGR	GU07020GR17220	UF	Field Duplicate	2/22/2007	-	-	x	-	-	x	-	x	x	x	x	x
R-17	1124	1134	WGR	UU07020GR17201	UF	-	2/22/2007	-	-	-	-	-	-	-	-	-	x	-	-
R-17	1124	1134	WGR	UU07020GR17220	UF	Field Duplicate	2/22/2007	-	-	-	-	-	-	-	-	-	x	-	-
R-17	1124	1134	WGR	GF07020GR17201	F	-	2/22/2007	-	-	x	-	-	-	-	x	-	x	-	-
R-17	1124	1134	WGR	GF07020GR17220	F	Field Duplicate	2/22/2007	-	-	x	-	-	-	-	x	-	x	-	-
R-17	1124	1134	WGR	SU07020GR17201	UF	-	2/22/2007	-	-	-	-	-	x	-	-	-	-	-	-
R-17	1124	1134	WGR	SU07020GR17220	UF	Field Duplicate	2/22/2007	-	-	-	-	-	x	-	-	-	-	-	-
R-17	1124	1134	WGR	GU07040GR17201	UF	-	4/25/2007	-	-	x	-	-	x	-	x	x	x	x	x
R-17	1124	1134	WGR	UU07040GR17201	UF	-	4/25/2007	-	-	-	-	-	-	-	-	-	x	-	-
R-17	1124	1134	WGR	GF07040GR17201	F	-	4/25/2007	-	-	x	-	-	-	-	x	-	x	-	-
R-17	1124	1134	WGR	SU07040GR17201	UF	-	4/25/2007	-	-	-	-	-	x	-	-	-	-	-	-
R-17	1124	1134	WGR	GU07060GR17201	UF	-	7/3/2007	-	-	x	-	-	x	-	x	x	x	x	x
R-17	1124	1134	WGR	UU07060GR17201	UF	-	7/3/2007	-	-	-	-	-	-	-	-	-	x	-	-

Table C-2.0-3 (continued)

Location ID	Top Depth (ft)	Bottom Depth (ft)	Media Description	Sample ID	Field Prep	Field QC Type	Collection Date	DIOX/FUR	DRO	GENINORG	GRO	Herb	HEXP	Isotope	Metals	Pest/PCB	RAD	SVOA	VOA
R-17	1124	1134	WGR	GF07060GR17201	F	-	7/3/2007	-	-	x	-	-	-	-	x	-	x	-	-
R-17	1124	1134	WGR	SU07060GR17201	UF	-	7/3/2007	-	-	-	-	-	x	-	-	-	-	-	-
R-17	1124	1134	WGR	GU07080GR17201	UF	-	9/18/2007	-	-	x	-	x	x	-	x	x	x	x	x
R-17	1124	1134	WGR	UU07080GR17201	UF	-	9/18/2007	-	-	-	-	-	-	-	-	-	x	-	-
R-17	1124	1134	WGR	GF07080GR17201	F	-	9/18/2007	-	-	x	-	-	-	-	x	-	x	-	-
R-17	1124	1134	WGR	SU07080GR17201	UF	-	9/18/2007	-	-	-	-	-	x	-	-	-	-	-	-
R-17	1124	1134	WGR	CAPA-08-9332	UF	-	12/6/2007	-	-	x	-	-	x	-	x	x	x	x	x
R-17	1124	1134	WGR	CAPA-08-9331	F	-	12/6/2007	-	-	x	-	-	-	-	x	-	x	-	-
R-17	1124	1134	WGR	CAPA-08-13164	UF	-	6/18/2008	-	-	x	-	-	x	-	x	x	x	x	x
R-17	1124	1134	WGR	CAPA-08-13163	F	-	6/18/2008	-	-	x	-	-	-	-	x	-	x	-	-
R-17	n/p	n/p	WGR	CAPA-08-11027	UF	-	3/13/2008	-	-	x	-	-	x	-	x	x	x	x	x
R-17	n/p	n/p	WGR	CAPA-08-11028	F	-	3/13/2008	-	-	x	-	-	-	-	x	-	x	-	-
R-17	n/p	n/p	WGR	CAPA-08-11033	UF	-	3/13/2008	-	-	x	-	-	x	-	x	x	x	x	x
R-17	n/p	n/p	WGR	CAPA-08-11031	F	-	3/13/2008	-	-	x	-	-	-	-	x	-	x	-	-
R-18	1358	1381	WGR	GU05080G18R01	UF	-	8/25/2005	-	-	x	-	-	x	-	x	x	x	x	x
R-18	1358	1381	WGR	UU05080G18R01	UF	-	8/25/2005	-	-	-	-	-	-	-	-	-	x	-	-

Table C-2.0-3 (continued)

Location ID	Top Depth (ft)	Bottom Depth (ft)	Media Description	Sample ID	Field Prep	Field QC Type	Collection Date	DIOX/FUR	DRO	GENINORG	GRO	Herb	HEXP	Isotope	Metals	Pest/PCB	RAD	SVOA	VOA
R-18	1358	1381	WGR	GF05080G18R01	F	-	8/25/2005	-	-	x	-	-	-	-	x	-	-	-	-
R-18	1358	1381	WGR	HF05080G18R01	F	-	8/25/2005	-	-	x	-	-	-	-	-	-	-	-	-
R-18	1358	1381	WGR	R-18-8-25-05	F	-	8/25/2005	-	-	-	-	-	-	x	-	-	-	-	-
R-18	1358	1381	WGR	GU05110G18R01	UF	-	12/1/2005	-	-	x	-	-	x	-	x	x	x	x	x
R-18	1358	1381	WGR	GU05110G18R90	UF	Field Duplicate	12/1/2005	-	-	x	-	-	x	-	x	x	x	x	x
R-18	1358	1381	WGR	UU05110G18R01	UF	-	12/1/2005	-	-	-	-	-	-	-	-	-	x	-	-
R-18	1358	1381	WGR	UU05110G18R90	UF	Field Duplicate	12/1/2005	-	-	-	-	-	-	-	-	-	x	-	-
R-18	1358	1381	WGR	GF05110G18R01	F	-	12/1/2005	-	-	x	-	-	-	-	x	-	-	-	-
R-18	1358	1381	WGR	GF05110G18R90	F	Field Duplicate	12/1/2005	-	-	x	-	-	-	-	x	-	-	-	-
R-18	1358	1381	WGR	HF05110G18R01	F	-	12/1/2005	-	-	x	-	-	-	-	-	-	-	-	-
R-18	1358	1381	WGR	HF05110G18R90	F	Field Duplicate	12/1/2005	-	-	x	-	-	-	-	-	-	-	-	-
R-18	1358	1381	WGR	R-18-12-01-05	F	-	12/1/2005	-	-	-	-	-	-	x	-	-	-	-	-
R-18	1358	1381	WGR	GU06020G18R01	UF	-	3/7/2006	-	-	x	-	-	-	-	x	x	x	x	x
R-18	1358	1381	WGR	UU06020G18R01	UF	-	3/7/2006	-	-	-	-	-	-	-	-	-	x	-	-

Table C-2.0-3 (continued)

Location ID	Top Depth (ft)	Bottom Depth (ft)	Media Description	Sample ID	Field Prep	Field QC Type	Collection Date	DIOX/FUR	DRO	GENINORG	GRO	Herb	HEXP	Isotope	Metals	Pest/PCB	RAD	SVOA	VOA
R-18	1358	1381	WGR	GF06020G18R01	F	-	3/7/2006	-	-	x	-	-	-	-	x	-	-	-	-
R-18	1358	1381	WGR	HF06020G18R01	F	-	3/7/2006	-	-	-	-	-	-	-	-	-	-	-	-
R-18	1358	1381	WGR	GU060500G18R01	UF	-	5/16/2006	-	-	x	-	-	-	-	x	x	x	x	x
R-18	1358	1381	WGR	GU060500G18R90	UF	Field Duplicate	5/16/2006	-	-	x	-	-	-	-	x	x	x	x	x
R-18	1358	1381	WGR	UU060500G18R01	UF	-	5/16/2006	-	-	-	-	-	-	-	-	-	x	-	-
R-18	1358	1381	WGR	UU060500G18R90	UF	Field Duplicate	5/16/2006	-	-	-	-	-	-	-	-	-	x	-	-
R-18	1358	1381	WGR	GF060500G18R01	F	-	5/16/2006	-	-	x	-	-	-	-	x	-	-	-	-
R-18	1358	1381	WGR	GF060500G18R90	F	Field Duplicate	5/16/2006	-	-	x	-	-	-	-	x	-	-	-	-
R-18	1358	1381	WGR	GU060800G18R01	UF	-	8/15/2006	-	-	x	-	x	x	-	x	x	x	x	x
R-18	1358	1381	WGR	GU060800G18R90	UF	Field Duplicate	8/15/2006	-	-	x	-	x	x	-	x	x	x	x	x
R-18	1358	1381	WGR	GF060800G18R01	F	-	8/15/2006	-	-	x	-	-	-	-	x	-	x	-	-
R-18	1358	1381	WGR	GF060800G18R90	F	Field Duplicate	8/15/2006	-	-	x	-	-	-	-	x	-	x	-	-
R-18	1358	1381	WGR	SU060800G18R01	UF	-	8/15/2006	-	-	-	-	-	x	-	-	-	-	-	-

Table C-2.0-3 (continued)

Location ID	Top Depth (ft)	Bottom Depth (ft)	Media Description	Sample ID	Field Prep	Field QC Type	Collection Date	DIOX/FUR	DRO	GENINORG	GRO	Herb	HEXP	Isotope	Metals	Pest/PCB	RAD	SVOA	VOA
R-18	1358	1381	WGR	SU060800G18R90	UF	Field Duplicate	8/15/2006	-	-	-	-	-	x	-	-	-	-	-	-
R-18	1358	1381	WGR	GU060800G18R01	F	-	8/15/2006	-	-	x	-	-	-	-	-	-	-	-	-
R-18	1358	1381	WGR	GU060800G18R90	F	Field Duplicate	8/15/2006	-	-	x	-	-	-	-	-	-	-	-	-
R-18	1358	1381	WGR	UU060800G18R01	UF	-	8/16/2006	-	-	-	-	-	-	-	-	-	x	-	-
R-18	1358	1381	WGR	UU060800G18R90	UF	Field Duplicate	8/16/2006	-	-	-	-	-	-	-	-	-	x	-	-
R-18	1358	1381	WGR	GU061200G18R01	UF	-	12/18/2006	-	-	x	-	-	x	-	x	x	x	x	x
R-18	1358	1381	WGR	GU061200G18R20	UF	Field Duplicate	12/18/2006	-	-	x	-	-	x	-	x	x	x	x	x
R-18	1358	1381	WGR	GF061200G18R01	F	-	12/18/2006	-	-	x	-	-	-	-	x	-	x	-	-
R-18	1358	1381	WGR	GF061200G18R20	F	Field Duplicate	12/18/2006	-	-	x	-	-	-	-	x	-	x	-	-
R-18	1358	1381	WGR	SU061200G18R01	UF	-	12/18/2006	-	-	-	-	-	x	-	-	-	-	-	-
R-18	1358	1381	WGR	SU061200G18R20	UF	Field Duplicate	12/18/2006	-	-	-	-	-	x	-	-	-	-	-	-
R-18	1358	1381	WGR	GU061200G18R01	F	-	12/18/2006	-	-	x	-	-	-	-	-	-	-	-	-
R-18	1358	1381	WGR	GU061200G18R20	F	Field	12/18/2006	-	-	x	-	-	-	-	-	-	-	-	-

Table C-2.0-3 (continued)

Location ID	Top Depth (ft)	Bottom Depth (ft)	Media Description	Sample ID	Field Prep	Field QC Type	Collection Date	DIOX/FUR	DRO	GENINORG	GRO	Herb	HEXP	Isotope	Metals	Pest/PCB	RAD	SVOA	VOA
						Duplicate													
R-18	1358	1381	WGR	GU070300G18R01	UF	-	3/22/2007	-	-	x	-	-	x	-	x	x	x	x	x
R-18	1358	1381	WGR	GU070300G18R20	UF	Field Duplicate	3/22/2007	-	-	x	-	-	x	-	x	x	x	x	x
R-18	1358	1381	WGR	UU070300G18R01	UF	-	3/22/2007	-	-	-	-	-	-	-	-	-	x	-	-
R-18	1358	1381	WGR	UU070300G18R20	UF	Field Duplicate	3/22/2007	-	-	-	-	-	-	-	-	-	x	-	-
R-18	1358	1381	WGR	GF070300G18R01	F	-	3/22/2007	-	-	x	-	-	-	-	x	-	x	-	-
R-18	1358	1381	WGR	GF070300G18R20	F	Field Duplicate	3/22/2007	-	-	x	-	-	-	-	x	-	x	-	-
R-18	1358	1381	WGR	GU070600G18R01	UF	-	6/26/2007	-	-	x	-	-	x	-	x	x	x	x	x
R-18	1358	1381	WGR	GU070600G18R20	UF	Field Duplicate	6/26/2007	-	-	x	-	-	x	-	x	x	x	-	x
R-18	1358	1381	WGR	UU070600G18R01	UF	-	6/26/2007	-	-	-	-	-	-	-	-	-	x	-	-
R-18	1358	1381	WGR	UU070600G18R20	UF	Field Duplicate	6/26/2007	-	-	-	-	-	-	-	-	-	x	-	-
R-18	1358	1381	WGR	GF070600G18R01	F	-	6/26/2007	-	-	x	-	-	-	-	x	-	x	-	-
R-18	1358	1381	WGR	GF070600G18R20	F	Field Duplicate	6/26/2007	-	-	x	-	-	-	-	x	-	x	-	-

Table C-2.0-3 (continued)

Location ID	Top Depth (ft)	Bottom Depth (ft)	Media Description	Sample ID	Field Prep	Field QC Type	Collection Date	DIOX/FUR	DRO	GENINORG	GRO	Herb	HEXP	Isotope	Metals	Pest/PCB	RAD	SVOA	VOA
R-18	1358	1381	WGR	SU070600G18R01	UF	-	6/26/2007	-	-	-	-	-	x	-	-	-	-	-	-
R-18	1358	1381	WGR	SU070600G18R20	UF	Field Duplicate	6/26/2007	-	-	-	-	-	x	-	-	-	-	-	-
R-18	1358	1381	WGR	GU070800G18R01	UF	-	9/4/2007	-	-	x	-	x	x	-	x	x	x	x	x
R-18	1358	1381	WGR	UU070800G18R01	UF	-	9/4/2007	-	-	-	-	-	-	-	-	-	x	-	-
R-18	1358	1381	WGR	GF070800G18R01	F	-	9/4/2007	-	-	x	-	-	-	-	x	-	x	-	-
R-18	1358	1381	WGR	SU070800G18R01	UF	-	9/4/2007	-	-	-	-	-	x	-	-	-	-	-	-
R-18	1358	1381	WGR	CAPA-08-9366	UF	-	12/4/2007	-	-	x	-	-	x	-	x	x	x	x	x
R-18	1358	1381	WGR	CAPA-08-9370	UF	Field Duplicate	12/4/2007	-	-	x	-	-	x	-	x	x	x	x	x
R-18	1358	1381	WGR	CAPA-08-9371	F	-	12/4/2007	-	-	x	-	-	-	-	x	-	x	-	-
R-18	1358	1381	WGR	CAPA-08-9369	F	Field Duplicate	12/4/2007	-	-	x	-	-	-	-	x	-	x	-	-
R-18	1358	1381	WGR	CAPA-08-13165	UF	-	6/25/2008	-	-	x	-	-	x	-	x	x	x	x	x
R-18	1358	1381	WGR	CAPA-08-13168	UF	Field Duplicate	6/25/2008	-	-	x	-	-	x	-	x	x	x	x	x
R-18	1358	1381	WGR	CAPA-08-13167	F	-	6/25/2008	-	-	x	-	-	-	-	x	-	x	-	-
R-18	1358	1381	WGR	CAPA-08-13169	F	Field	6/25/2008	-	-	x	-	-	-	-	x	-	x	-	-

Table C-2.0-3 (continued)

Location ID	Top Depth (ft)	Bottom Depth (ft)	Media Description	Sample ID	Field Prep	Field QC Type	Collection Date	DIOX/FUR	DRO	GENINORG	GRO	Herb	HEXP	Isotope	Metals	Pest/PCB	RAD	SVOA	VOA
						Duplicate													
R-18	n/p	n/p	WGR	CAPA-08-11037	UF	-	3/7/2008	-	-	x	-	-	x	-	x	x	x	x	x
R-18	n/p	n/p	WGR	CAPA-08-11039	F	-	3/7/2008	-	-	x	-	-	-	-	x	-	x	-	-
R-19	893.3	909.6	WGI	CATH-00-0041	F	-	9/22/2000	-	-	x	-	-	-	-	x	-	x	-	-
R-19	893.3	909.6	WGI	CATH-00-0042	UF	-	9/22/2000	-	-	x	-	-	x	-	-	x	-	x	x
R-19	893.3	909.6	WGI	CATH-00-0052	F	-	9/25/2000	-	-	x	-	-	-	x	x	-	x	-	-
R-19	893.3	909.6	WGI	GW19-01-0003	UF	-	4/10/2001	-	-	x	-	-	x	x	x	x	x	x	x
R-19	893.3	909.6	WGI	GW19-01-0004	F	-	4/10/2001	-	-	x	-	-	-	-	x	-	x	-	-
R-19	893.3	909.6	WGI	GW19-01-0018	F	-	7/5/2001	-	-	x	-	-	-	-	x	-	x	-	-
R-19	893.3	909.6	WGI	GW19-01-0017	UF	-	7/5/2001	-	-	x	-	-	x	x	x	x	x	x	x
R-19	893.3	909.6	WGI	GW19-01-0032	UF	-	9/13/2001	-	-	x	-	-	x	x	x	x	x	x	x
R-19	893.3	909.6	WGI	GW19-01-0033	F	-	9/13/2001	-	-	x	-	-	-	-	x	-	x	-	-
R-19	893.3	909.6	WGI	GU0208G19R201	UF	-	8/20/2002	-	-	x	-	-	-	-	x	x	-	x	x
R-19	893.3	909.6	WGI	UU0208G19R201	UF	-	8/20/2002	-	-	-	-	-	-	-	-	-	x	-	-
R-19	893.3	909.6	WGI	GU0208G19R201	F	-	8/20/2002	-	-	x	-	-	-	-	-	-	-	-	-
R-19	893.3	909.6	WGI	GW19-02-47879	UF	-	8/22/2002	-	-	-	-	-	-	x	-	-	-	-	-
R-19	893.3	909.6	WGI	UU0312G19R201	UF	-	12/15/2003	-	-	-	-	-	-	-	-	-	x	-	-

Table C-2.0-3 (continued)

Location ID	Top Depth (ft)	Bottom Depth (ft)	Media Description	Sample ID	Field Prep	Field QC Type	Collection Date	DIOX/FUR	DRO	GENINORG	GRO	Herb	HEXP	Isotope	Metals	Pest/PCB	RAD	SVOA	VOA
R-19	893.3	909.6	WGI	GU0312G19R201	UF	-	12/15/2003	-	-	x	-	-	x	-	x	-	-	-	-
R-19	893.3	909.6	WGI	GU0312G19R201	F	-	12/15/2003	-	-	x	-	-	-	-	-	-	-	-	-
R-19	893.3	909.6	WGI	GU0406G19R201	UF	-	6/10/2004	-	-	x	-	-	x	-	x	-	x	-	-
R-19	893.3	909.6	WGI	GU0406G19R201	F	-	6/10/2004	-	-	x	-	-	-	-	-	-	-	-	-
R-19	893.3	909.6	WGI	GF0507G19R201	F	-	7/21/2005	-	-	x	-	-	-	-	x	-	x	-	-
R-19	893.3	909.6	WGI	GU0507G19R201	UF	-	7/21/2005	-	-	x	-	-	x	-	x	-	x	-	-
R-19	893.3	909.6	WGI	UU06080G19R201	UF	-	8/18/2006	-	-	-	-	-	-	-	-	-	x	-	-
R-19	893.3	909.6	WGI	UU06120G19R201	UF	-	12/11/2006	-	-	-	-	-	-	-	-	-	x	-	-
R-19	893.3	909.6	WGI	UU07030G19R201	UF	-	4/2/2007	-	-	-	-	-	-	-	-	-	x	-	-
R-19	893.3	909.6	WGI	UU07060G19R201	UF	-	6/26/2007	-	-	-	-	-	-	-	-	-	x	-	-
R-19	893.3	909.6	WGI	UU07080G19R201	UF	-	9/4/2007	-	-	-	-	-	-	-	-	-	x	-	-
R-19	893.3	909.6	WGI	GU07080G19R201	UF	-	9/4/2007	-	-	-	-	x	-	-	-	-	-	-	-
R-19	893.3	909.6	WGI	CAPA-08-13156	UF	-	6/18/2008	-	-	-	-	-	-	-	-	-	x	-	-
R-19	1171.4	1215.4	WGR	CATH-00-0043	F	-	9/26/2000	-	-	x	-	-	-	-	x	-	x	-	-
R-19	1171.4	1215.4	WGR	CATH-00-0044	UF	-	9/26/2000	-	-	x	-	-	x	x	x	x	x	x	x
R-19	1171.4	1215.4	WGR	GW19-01-0005	UF	-	4/9/2001	-	-	x	-	-	x	x	x	x	x	x	x

Table C-2.0-3 (continued)

Location ID	Top Depth (ft)	Bottom Depth (ft)	Media Description	Sample ID	Field Prep	Field QC Type	Collection Date	DIOX/FUR	DRO	GENINORG	GRO	Herb	HEXP	Isotope	Metals	Pest/PCB	RAD	SVOA	VOA
R-19	1171.4	1215.4	WGR	GW19-01-0006	F	-	4/9/2001	-	-	x	-	-	-	-	x	-	x	-	-
R-19	1171.4	1215.4	WGR	GW19-01-0019	UF	-	7/10/2001	-	-	x	-	-	x	x	x	x	x	x	x
R-19	1171.4	1215.4	WGR	GW19-01-0020	F	-	7/10/2001	-	-	x	-	-	-	-	x	-	x	-	-
R-19	1171.4	1215.4	WGR	GW19-01-0034	UF	-	9/18/2001	-	-	x	-	-	x	x	x	x	x	x	x
R-19	1171.4	1215.4	WGR	GW19-01-0035	F	-	9/18/2001	-	-	x	-	-	-	-	x	-	x	-	-
R-19	1171.4	1215.4	WGR	GW19-01-0036	UF	-	9/19/2001	-	-	x	-	-	x	x	x	x	x	x	x
R-19	1171.4	1215.4	WGR	GW19-01-0037	F	-	9/19/2001	-	-	x	-	-	-	-	x	-	x	-	-
R-19	1171.4	1215.4	WGR	GW19-02-47880	UF	-	8/22/2002	-	-	-	-	-	-	x	-	-	-	-	-
R-19	1171.4	1215.4	WGR	GU0208G19R301	UF	-	8/22/2002	-	-	x	-	-	-	-	x	x	-	x	x
R-19	1171.4	1215.4	WGR	UU0208G19R301	UF	-	8/22/2002	-	-	-	-	-	-	-	-	-	x	-	-
R-19	1171.4	1215.4	WGR	GU0208G19R301	F	-	8/22/2002	-	-	x	-	-	-	-	-	-	-	-	-
R-19	1171.4	1215.4	WGR	UU0312G19R301	UF	-	12/15/2003	-	-	-	-	-	-	-	-	-	x	-	-
R-19	1171.4	1215.4	WGR	GU0312G19R301	UF	-	12/15/2003	-	-	x	-	-	x	-	x	-	-	-	-
R-19	1171.4	1215.4	WGR	GU0312G19R301	F	-	12/15/2003	-	-	x	-	-	-	-	-	-	-	-	-
R-19	1171.4	1215.4	WGR	GU0406G19R301	UF	-	6/14/2004	-	-	x	-	-	x	-	x	x	x	x	x
R-19	1171.4	1215.4	WGR	GU0406G19R301	F	-	6/14/2004	-	-	x	-	-	-	-	-	-	-	-	-

Table C-2.0-3 (continued)

Location ID	Top Depth (ft)	Bottom Depth (ft)	Media Description	Sample ID	Field Prep	Field QC Type	Collection Date	DIOX/FUR	DRO	GENINORG	GRO	Herb	HEXP	Isotope	Metals	Pest/PCB	RAD	SVOA	VOA
R-19	1171.4	1215.4	WGR	GU0507G19R301	UF	-	7/21/2005	-	-	x	-	-	x	-	x	x	x	x	x
R-19	1171.4	1215.4	WGR	GF0507G19R301	F	-	7/21/2005	-	-	x	-	-	-	-	x	-	x	-	-
R-19	1171.4	1215.4	WGR	UU06080G19R301	UF	-	8/15/2006	-	-	-	-	-	-	-	-	-	x	-	-
R-19	1171.4	1215.4	WGR	SU06080G19R301	UF	-	8/15/2006	-	-	-	-	-	x	-	-	-	-	-	-
R-19	1171.4	1215.4	WGR	GU06080G19R301	UF	-	8/15/2006	-	-	-	-	-	x	-	-	-	-	-	-
R-19	1171.4	1215.4	WGR	UU06120G19R301	UF	-	12/11/2006	-	-	-	-	-	-	-	-	-	x	-	-
R-19	1171.4	1215.4	WGR	SU06120G19R301	UF	-	12/11/2006	-	-	-	-	-	x	-	-	-	-	-	-
R-19	1171.4	1215.4	WGR	GU06120G19R301	UF	-	12/11/2006	-	-	-	-	-	x	-	-	-	-	-	-
R-19	1171.4	1215.4	WGR	UU07030G19R301	UF	-	4/2/2007	-	-	-	-	-	-	-	-	-	x	-	-
R-19	1171.4	1215.4	WGR	SU07030G19R301	UF	-	4/2/2007	-	-	-	-	-	x	-	-	-	-	-	-
R-19	1171.4	1215.4	WGR	GU07030G19R301	UF	-	4/2/2007	-	-	-	-	-	x	-	-	-	-	-	-
R-19	1171.4	1215.4	WGR	UU07060G19R301	UF	-	7/2/2007	-	-	-	-	-	-	-	-	-	x	-	-
R-19	1171.4	1215.4	WGR	SU07060G19R301	UF	-	7/2/2007	-	-	-	-	-	x	-	-	-	-	-	-
R-19	1171.4	1215.4	WGR	GU07060G19R301	UF	-	7/2/2007	-	-	-	-	-	x	-	-	-	-	-	-
R-19	1171.4	1215.4	WGR	UU07080G19R301	UF	-	9/4/2007	-	-	-	-	-	-	-	-	-	x	-	-
R-19	1171.4	1215.4	WGR	SU07080G19R301	UF	-	9/4/2007	-	-	-	-	-	x	-	-	-	-	-	-

Table C-2.0-3 (continued)

Location ID	Top Depth (ft)	Bottom Depth (ft)	Media Description	Sample ID	Field Prep	Field QC Type	Collection Date	DIOX/FUR	DRO	GENINORG	GRO	Herb	HEXP	Isotope	Metals	Pest/PCB	RAD	SVOA	VOA
R-19	1171.4	1215.4	WGR	GU07080G19R301	UF	-	9/4/2007	-	-	-	-	x	x	-	-	-	-	-	-
R-19	1171.4	1215.4	WGR	CAPA-08-13215	UF	-	6/17/2008	-	-	-	-	-	x	-	-	-	x	-	-
R-19	1410.2	1417.4	WGR	GW19-01-0007	UF	-	4/6/2001	-	-	x	-	-	x	x	x	x	x	x	x
R-19	1410.2	1417.4	WGR	GW19-01-0008	F	-	4/9/2001	-	-	x	-	-	-	-	x	-	x	-	-
R-19	1410.2	1417.4	WGR	GW19-01-0021	UF	-	7/11/2001	-	-	x	-	-	x	x	x	x	x	x	x
R-19	1410.2	1417.4	WGR	GW19-01-0022	F	-	7/11/2001	-	-	x	-	-	-	-	x	-	x	-	-
R-19	1410.2	1417.4	WGR	GW19-02-47881	UF	-	8/26/2002	-	-	-	-	-	-	x	-	-	-	-	-
R-19	1410.2	1417.4	WGR	GU0208G19R401	UF	-	8/26/2002	-	-	x	-	-	-	-	x	x	-	x	x
R-19	1410.2	1417.4	WGR	UU0208G19R401	UF	-	8/26/2002	-	-	-	-	-	-	-	-	-	x	-	-
R-19	1410.2	1417.4	WGR	GU0208G19R401	F	-	8/26/2002	-	-	x	-	-	-	-	-	-	-	-	-
R-19	1410.2	1417.4	WGR	UU0312G19R401	UF	-	12/16/2003	-	-	-	-	-	-	-	-	-	x	-	-
R-19	1410.2	1417.4	WGR	GU0312G19R401	UF	-	12/16/2003	-	-	x	-	-	x	-	x	-	-	-	-
R-19	1410.2	1417.4	WGR	GU0312G19R401	F	-	12/16/2003	-	-	x	-	-	-	-	-	-	-	-	-
R-19	1410.2	1417.4	WGR	GU0406G19R401	UF	-	6/15/2004	-	-	x	-	-	x	-	x	-	x	x	x
R-19	1410.2	1417.4	WGR	GU0406G19R401	F	-	6/15/2004	-	-	x	-	-	-	-	-	-	-	-	-
R-19	1410.2	1417.4	WGR	GU0507G19R401	UF	-	7/28/2005	-	-	x	-	-	x	-	x	-	x	x	x

Table C-2.0-3 (continued)

Location ID	Top Depth (ft)	Bottom Depth (ft)	Media Description	Sample ID	Field Prep	Field QC Type	Collection Date	DIOX/FUR	DRO	GENINORG	GRO	Herb	HEXP	Isotope	Metals	Pest/PCB	RAD	SVOA	VOA
R-19	1410.2	1417.4	WGR	GF0507G19R401	F	-	7/28/2005	-	-	x	-	-	-	-	x	-	x	-	-
R-19	1410.2	1417.4	WGR	GU06080G19R401	UF	-	8/16/2006	-	-	x	-	x	x	-	x	x	x	x	x
R-19	1410.2	1417.4	WGR	UU06080G19R401	UF	-	8/16/2006	-	-	-	-	-	-	-	-	-	x	-	-
R-19	1410.2	1417.4	WGR	GF06080G19R401	F	-	8/16/2006	-	-	x	-	-	-	-	x	-	x	-	-
R-19	1410.2	1417.4	WGR	SU06080G19R401	UF	-	8/16/2006	-	-	-	-	-	x	-	-	-	-	-	-
R-19	1410.2	1417.4	WGR	GU06080G19R401	F	-	8/16/2006	-	-	x	-	-	-	-	-	-	-	-	-
R-19	1410.2	1417.4	WGR	GU06120G19R401	UF	-	12/12/2006	-	-	x	-	-	-	-	x	x	x	x	x
R-19	1410.2	1417.4	WGR	GF06120G19R401	F	-	12/12/2006	-	-	x	-	-	-	-	x	-	x	-	-
R-19	1410.2	1417.4	WGR	SU06120G19R401	UF	-	12/12/2006	-	-	-	-	-	x	-	-	-	-	-	-
R-19	1410.2	1417.4	WGR	GU06120G19R401	F	-	12/12/2006	-	-	x	-	-	-	-	-	-	-	-	-
R-19	1410.2	1417.4	WGR	GU07030G19R401	UF	-	4/3/2007	-	-	x	-	-	x	-	x	x	x	x	x
R-19	1410.2	1417.4	WGR	UU07030G19R401	UF	-	4/3/2007	-	-	-	-	-	-	-	-	-	x	-	-
R-19	1410.2	1417.4	WGR	GF07030G19R401	F	-	4/3/2007	-	-	x	-	-	-	-	x	-	x	-	-
R-19	1410.2	1417.4	WGR	SU07030G19R401	UF	-	4/3/2007	-	-	-	-	-	x	-	-	-	-	-	-
R-19	1410.2	1417.4	WGR	GU07060G19R401	UF	-	6/28/2007	-	-	x	-	-	x	-	x	x	x	x	x
R-19	1410.2	1417.4	WGR	UU07060G19R401	UF	-	6/28/2007	-	-	-	-	-	-	-	-	-	x	-	-

Table C-2.0-3 (continued)

Location ID	Top Depth (ft)	Bottom Depth (ft)	Media Description	Sample ID	Field Prep	Field QC Type	Collection Date	DIOX/FUR	DRO	GENINORG	GRO	Herb	HEXP	Isotope	Metals	Pest/PCB	RAD	SVOA	VOA
R-19	1410.2	1417.4	WGR	GF07060G19R401	F	-	6/28/2007	-	-	x	-	-	-	-	x	-	x	-	-
R-19	1410.2	1417.4	WGR	SU07060G19R401	UF	-	6/28/2007	-	-	-	-	-	x	-	-	-	-	-	-
R-19	1410.2	1417.4	WGR	UU07080G19R401	UF	-	9/10/2007	-	-	-	-	-	-	-	-	-	x	-	-
R-19	1410.2	1417.4	WGR	GU07080G19R401	UF	-	9/10/2007	-	-	x	-	x	x	-	x	x	x	-	-
R-19	1410.2	1417.4	WGR	GF07080G19R401	F	-	9/10/2007	-	-	x	-	-	-	-	x	-	x	-	-
R-19	1410.2	1417.4	WGR	SU07080G19R401	UF	-	9/10/2007	-	-	-	-	-	x	-	-	-	-	-	-
R-19	1410.2	1417.4	WGR	CAPA-08-9380	UF	-	12/6/2007	-	-	x	-	-	x	-	x	x	x	x	x
R-19	1410.2	1417.4	WGR	CAPA-08-9381	F	-	12/6/2007	-	-	x	-	-	-	-	x	-	x	-	-
R-19	1410.2	1417.4	WGR	CAPA-08-13172	UF	-	6/11/2008	-	-	x	-	-	x	-	x	x	x	x	x
R-19	1410.2	1417.4	WGR	CAPA-08-13174	F	-	6/11/2008	-	-	x	-	-	-	-	x	-	x	-	-
R-19	1582.6	1589.8	WGR	CATH-00-0050	UF	-	10/10/2000	-	-	-	-	-	x	x	-	-	x	-	-
R-19	1582.6	1589.8	WGR	GW19-01-0009	UF	-	4/4/2001	-	-	x	-	-	x	x	x	x	x	x	x
R-19	1582.6	1589.8	WGR	GW19-01-0015	UF	Field Duplicate	4/4/2001	-	-	x	-	-	x	x	x	x	x	x	x
R-19	1582.6	1589.8	WGR	GW19-01-0010	F	-	4/5/2001	-	-	x	-	-	-	-	x	-	x	-	-
R-19	1582.6	1589.8	WGR	GW19-01-0016	F	Field Duplicate	4/5/2001	-	-	x	-	-	-	-	x	-	x	-	-

Table C-2.0-3 (continued)

Location ID	Top Depth (ft)	Bottom Depth (ft)	Media Description	Sample ID	Field Prep	Field QC Type	Collection Date	DIOX/FUR	DRO	GENINORG	GRO	Herb	HEXP	Isotope	Metals	Pest/PCB	RAD	SVOA	VOA
R-19	1582.6	1589.8	WGR	GW19-01-0023	UF	-	7/12/2001	-	-	x	-	-	x	x	x	x	x	x	x
R-19	1582.6	1589.8	WGR	GW19-01-0024	F	-	7/12/2001	-	-	x	-	-	-	-	x	-	x	-	-
R-19	1582.6	1589.8	WGR	GW19-01-0038	UF	-	9/20/2001	-	-	x	-	-	x	x	x	x	x	x	x
R-19	1582.6	1589.8	WGR	GW19-01-0039	F	-	9/20/2001	-	-	x	-	-	-	-	x	-	x	-	-
R-19	1582.6	1589.8	WGR	GW19-02-47882	UF	-	8/23/2002	-	-	-	-	-	-	x	-	-	-	-	-
R-19	1582.6	1589.8	WGR	GU0208G19R501	UF	-	8/23/2002	-	-	x	-	-	-	-	x	x	-	x	x
R-19	1582.6	1589.8	WGR	UU0208G19R501	UF	-	8/23/2002	-	-	-	-	-	-	-	-	-	x	-	-
R-19	1582.6	1589.8	WGR	GU0208G19R501	F	-	8/23/2002	-	-	x	-	-	-	-	-	-	-	-	-
R-19	1582.6	1589.8	WGR	UU0312G19R501	UF	-	12/16/2003	-	-	-	-	-	-	-	-	-	x	-	-
R-19	1582.6	1589.8	WGR	GU0312G19R501	UF	-	12/16/2003	-	-	x	-	-	x	-	x	-	-	-	-
R-19	1582.6	1589.8	WGR	GU0312G19R501	F	-	12/16/2003	-	-	x	-	-	-	-	-	-	-	-	-
R-19	1582.6	1589.8	WGR	UU06080G19R501	UF	-	8/17/2006	-	-	-	-	-	-	-	-	-	x	-	-
R-19	1582.6	1589.8	WGR	UU06120G19R501	UF	-	12/11/2006	-	-	-	-	-	-	-	-	-	x	-	-
R-19	1582.6	1589.8	WGR	UU07030G19R501	UF	-	4/3/2007	-	-	-	-	-	-	-	-	-	x	-	-
R-19	1582.6	1589.8	WGR	UU07060G19R501	UF	-	6/26/2007	-	-	-	-	-	-	-	-	-	x	-	-
R-19	1582.6	1589.8	WGR	UU07090G19R501	UF	-	9/5/2007	-	-	-	-	-	-	-	-	-	x	-	-

Table C-2.0-3 (continued)

Location ID	Top Depth (ft)	Bottom Depth (ft)	Media Description	Sample ID	Field Prep	Field QC Type	Collection Date	DIOX/FUR	DRO	GENINORG	GRO	Herb	HEXP	Isotope	Metals	Pest/PCB	RAD	SVOA	VOA
R-19	1582.6	1589.8	WGR	GU07090G19R501	UF	-	9/5/2007	-	-	-	-	x	-	-	-	-	-	-	-
R-19	1582.6	1589.8	WGR	CAPA-08-13188	UF	-	6/16/2008	-	-	-	-	-	-	-	-	-	x	-	-
R-19	1726.8	1733.9	WGR	CATH-00-0048	UF	-	10/4/2000	-	-	x	-	-	x	x	x	x	x	x	x
R-19	1726.8	1733.9	WGR	CATH-00-0047	F	-	10/4/2000	-	-	x	-	-	-	-	x	-	x	-	-
R-19	1726.8	1733.9	WGR	GW19-01-0011	UF	-	4/2/2001	-	-	x	-	-	x	x	x	x	x	x	x
R-19	1726.8	1733.9	WGR	GW19-01-0012	F	-	4/2/2001	-	-	x	-	-	-	-	x	-	x	-	-
R-19	1726.8	1733.9	WGR	GW19-01-0025	UF	-	7/16/2001	-	-	x	-	-	x	x	x	x	x	x	x
R-19	1726.8	1733.9	WGR	GW19-01-0026	F	-	7/16/2001	-	-	x	-	-	-	-	x	-	x	-	-
R-19	1726.8	1733.9	WGR	GW19-01-0040	UF	-	9/21/2001	-	-	x	-	-	x	x	x	x	x	x	x
R-19	1726.8	1733.9	WGR	GW19-01-0041	F	-	9/21/2001	-	-	x	-	-	-	-	x	-	x	-	-
R-19	1726.8	1733.9	WGR	GW19-02-47883	UF	-	8/27/2002	-	-	-	-	-	-	x	-	-	-	-	-
R-19	1726.8	1733.9	WGR	GU0208G19R601	UF	-	8/27/2002	-	-	x	-	-	-	-	x	x	-	x	x
R-19	1726.8	1733.9	WGR	UU0208G19R601	UF	-	8/27/2002	-	-	-	-	-	-	-	-	-	x	-	-
R-19	1726.8	1733.9	WGR	GU0208G19R601	F	-	8/27/2002	-	-	x	-	-	-	-	-	-	-	-	-
R-19	1726.8	1733.9	WGR	UU0312G19R601	UF	-	12/16/2003	-	-	-	-	-	-	-	-	-	x	-	-
R-19	1726.8	1733.9	WGR	GU0312G19R601	UF	-	12/16/2003	-	-	x	-	-	-	-	x	-	-	-	-

Table C-2.0-3 (continued)

Location ID	Top Depth (ft)	Bottom Depth (ft)	Media Description	Sample ID	Field Prep	Field QC Type	Collection Date	DIOX/FUR	DRO	GENINORG	GRO	Herb	HEXP	Isotope	Metals	Pest/PCB	RAD	SVOA	VOA
R-19	1726.8	1733.9	WGR	GU0312G19R601	F	-	12/16/2003	-	-	x	-	-	-	-	-	-	-	-	-
R-19	1726.8	1733.9	WGR	GU0312G19R602	UF	-	12/22/2003	-	-	-	-	-	x	-	-	-	-	-	-
R-19	1726.8	1733.9	WGR	UU06080G19R601	UF	-	8/17/2006	-	-	-	-	-	-	-	-	-	x	-	-
R-19	1726.8	1733.9	WGR	UU06120G19R601	UF	-	12/11/2006	-	-	-	-	-	-	-	-	-	x	-	-
R-19	1726.8	1733.9	WGR	UU07030G19R601	UF	-	4/3/2007	-	-	-	-	-	-	-	-	-	x	-	-
R-19	1726.8	1733.9	WGR	UU07060G19R601	UF	-	6/27/2007	-	-	-	-	-	-	-	-	-	x	-	-
R-19	1726.8	1733.9	WGR	CAPA-08-9399	UF	-	12/7/2007	-	-	-	-	x	-	-	-	-	x	-	-
R-19	1726.8	1733.9	WGR	CAPA-08-13190	UF	-	6/16/2008	-	-	-	-	-	-	-	-	-	x	-	-
R-19	1832.4	1839.5	WGR	CATH-00-0046	UF	-	10/3/2000	-	-	-	-	-	x	x	-	-	x	-	-
R-19	1832.4	1839.5	WGR	CATH-00-0045	F	-	10/3/2000	-	-	x	-	-	-	-	x	-	x	-	-
R-19	1832.4	1839.5	WGR	GW19-01-0013	UF	-	3/29/2001	-	-	x	-	-	x	x	x	x	x	x	x
R-19	1832.4	1839.5	WGR	GW19-01-0014	F	-	3/30/2001	-	-	x	-	-	-	-	x	-	x	-	-
R-19	1832.4	1839.5	WGR	GW19-01-0027	UF	-	7/17/2001	-	-	x	-	-	x	x	x	x	x	x	x
R-19	1832.4	1839.5	WGR	GW19-01-0028	F	-	7/17/2001	-	-	x	-	-	-	-	x	-	x	-	-
R-19	1832.4	1839.5	WGR	GW19-01-0042	UF	-	9/24/2001	-	-	x	-	-	x	x	x	x	x	x	x
R-19	1832.4	1839.5	WGR	GW19-01-0043	F	-	9/24/2001	-	-	x	-	-	-	-	x	-	x	-	-

Table C-2.0-3 (continued)

Location ID	Top Depth (ft)	Bottom Depth (ft)	Media Description	Sample ID	Field Prep	Field QC Type	Collection Date	DIOX/FUR	DRO	GENINORG	GRO	Herb	HEXP	Isotope	Metals	Pest/PCB	RAD	SVOA	VOA
R-19	1832.4	1839.5	WGR	GW19-02-47884	UF	-	8/26/2002	-	-	-	-	-	-	x	-	-	-	-	-
R-19	1832.4	1839.5	WGR	GU0208G19R701	UF	-	8/26/2002	-	-	x	-	-	-	-	x	x	-	x	x
R-19	1832.4	1839.5	WGR	UU0208G19R701	UF	-	8/26/2002	-	-	-	-	-	-	-	-	-	x	-	-
R-19	1832.4	1839.5	WGR	GU0208G19R701	F	-	8/26/2002	-	-	x	-	-	-	-	-	-	-	-	-
R-19	1832.4	1839.5	WGR	UU0312G19R701	UF	-	12/17/2003	-	-	-	-	-	-	-	-	-	x	-	-
R-19	1832.4	1839.5	WGR	GU0312G19R701	UF	-	12/17/2003	-	-	x	-	-	x	-	x	-	-	-	-
R-19	1832.4	1839.5	WGR	GU0312G19R701	F	-	12/17/2003	-	-	x	-	-	-	-	-	-	-	-	-
R-19	1832.4	1839.5	WGR	GU0406G19R701	UF	-	6/16/2004	-	-	x	-	-	x	-	x	-	x	x	x
R-19	1832.4	1839.5	WGR	GU0406G19R701	F	-	6/16/2004	-	-	x	-	-	-	-	-	-	-	-	-
R-19	1832.4	1839.5	WGR	GU0507G19R701	UF	-	7/28/2005	-	-	x	-	-	x	-	x	-	x	x	x
R-19	1832.4	1839.5	WGR	GF0507G19R701	F	-	7/28/2005	-	-	x	-	-	-	-	x	-	x	-	-
R-19	1832.4	1839.5	WGR	UU06080G19R701	UF	-	8/18/2006	-	-	-	-	-	-	-	-	-	x	-	-
R-19	1832.4	1839.5	WGR	UU07030G19R701	UF	-	4/3/2007	-	-	-	-	-	-	-	-	-	x	-	-
R-19	1832.4	1839.5	WGR	UU07060G19R701	UF	-	6/27/2007	-	-	-	-	-	-	-	-	-	x	-	-
R-19	1832.4	1839.5	WGR	UU07080G19R701	UF	-	9/4/2007	-	-	-	-	-	-	-	-	-	x	-	-
R-19	1832.4	1839.5	WGR	GU07080G19R701	UF	-	9/4/2007	-	-	-	-	x	-	-	-	-	-	-	-

Table C-2.0-3 (continued)

Location ID	Top Depth (ft)	Bottom Depth (ft)	Media Description	Sample ID	Field Prep	Field QC Type	Collection Date	DIOX/FUR	DRO	GENINORG	GRO	Herb	HEXP	Isotope	Metals	Pest/PCB	RAD	SVOA	VOA
R-19	1832.4	1839.5	WGR	CAPA-08-13193	UF	-	6/16/2008	-	-	-	-	-	-	-	-	-	x	-	-
R-19	n/p	n/p	WGR	CAPA-08-9396	UF	-	12/6/2007	-	-	-	-	-	-	-	-	-	x	-	-
R-19	n/p	n/p	WGI	CAPA-08-9392	UF	-	12/10/2007	-	-	-	-	-	-	-	-	-	x	-	-
R-19	n/p	n/p	WGR	CAPA-08-9394	UF	-	12/10/2007	-	-	-	-	-	-	-	-	-	x	-	-
R-19	n/p	n/p	WGR	CAPA-08-9400	UF	-	12/10/2007	-	-	-	-	-	-	-	-	-	x	-	-
R-19	n/p	n/p	WGR	CAPA-08-11034	UF	-	3/13/2008	-	-	x	-	-	x	-	x	x	x	x	x
R-19	n/p	n/p	WGR	CAPA-08-11036	F	-	3/13/2008	-	-	x	-	-	-	-	x	-	x	-	-
R-19	n/p	n/p	WGR	CAPA-08-11069	UF	-	3/14/2008	-	-	-	-	-	-	-	-	-	x	-	x
R-19	n/p	n/p	WGR	CAPA-08-11072	UF	-	3/14/2008	-	-	-	-	-	-	-	-	-	x	-	x
R-19	n/p	n/p	WGR	CAPA-08-11084	UF	-	3/14/2008	-	-	-	-	-	-	-	-	-	x	-	x
R-19	n/p	n/p	WGI	CAPA-08-11061	UF	-	3/14/2008	-	-	-	-	-	-	-	-	-	x	-	x
R-19	n/p	n/p	WGR	CAPA-08-11068	UF	-	3/17/2008	-	-	-	-	-	x	-	-	-	x	-	x
R-20	904.6	912.2	WGR	GF0403G20R101	F	-	3/11/2004	-	-	x	-	-	-	-	x	-	-	-	-
R-20	904.6	912.2	WGR	GU0403G20R101	UF	-	3/15/2004	-	-	x	-	-	x	-	x	x	x	x	x
R-20	904.6	912.2	WGR	UU0403G20R101	UF	-	3/15/2004	-	-	-	-	-	-	-	-	-	x	-	-
R-20	904.6	912.2	WGR	HF0403G20R101	F	-	3/15/2004	-	-	x	-	-	-	-	-	-	-	-	-

Table C-2.0-3 (continued)

Location ID	Top Depth (ft)	Bottom Depth (ft)	Media Description	Sample ID	Field Prep	Field QC Type	Collection Date	DIOX/FUR	DRO	GENINORG	GRO	Herb	HEXP	Isotope	Metals	Pest/PCB	RAD	SVOA	VOA
R-20	904.6	912.2	WGR	UU0405G20R101	UF	-	5/10/2004	-	-	-	-	-	-	-	-	-	x	-	-
R-20	904.6	912.2	WGR	GU0405G20R101	UF	-	5/11/2004	-	-	x	-	-	x	-	x	x	x	x	x
R-20	904.6	912.2	WGR	GU0405G20R190	UF	Field Duplicate	5/11/2004	-	-	x	-	-	x	-	-	x	-	x	x
R-20	904.6	912.2	WGR	GF0405G20R101	F	-	5/11/2004	-	-	x	-	-	-	-	x	-	-	-	-
R-20	904.6	912.2	WGR	HF0405G20R101	F	-	5/11/2004	-	-	x	-	-	-	-	-	-	-	-	-
R-20	904.6	912.2	WGR	HF0405G20R190	F	Field Duplicate	5/11/2004	-	-	x	-	-	-	-	-	-	-	-	-
R-20	904.6	912.2	WGR	GU0409G20R101	UF	-	9/20/2004	-	-	x	-	-	x	-	x	x	x	x	x
R-20	904.6	912.2	WGR	UU0409G20R101	UF	-	9/20/2004	-	-	-	-	-	-	-	-	-	x	-	-
R-20	904.6	912.2	WGR	GF0409G20R101	F	-	9/20/2004	-	-	x	-	-	-	-	x	-	-	-	-
R-20	904.6	912.2	WGR	HF0409G20R101	F	-	9/20/2004	-	-	x	-	-	-	-	-	-	-	-	-
R-20	904.6	912.2	WGR	GU0411G20R101	UF	-	11/4/2004	-	-	x	-	-	x	-	x	x	x	x	x
R-20	904.6	912.2	WGR	UU0411G20R101	UF	-	11/4/2004	-	-	-	-	-	-	-	-	-	x	-	-
R-20	904.6	912.2	WGR	GF0411G20R101	F	-	11/4/2004	-	-	x	-	-	-	-	x	-	-	-	-
R-20	904.6	912.2	WGR	HF0411G20R101	F	-	11/4/2004	-	-	x	-	-	-	-	-	-	-	-	-
R-20	904.6	912.2	WGR	GU0507G20R101	UF	-	7/20/2005	-	-	x	-	-	-	-	x	x	x	x	x

Table C-2.0-3 (continued)

Location ID	Top Depth (ft)	Bottom Depth (ft)	Media Description	Sample ID	Field Prep	Field QC Type	Collection Date	DIOX/FUR	DRO	GENINORG	GRO	Herb	HEXP	Isotope	Metals	Pest/PCB	RAD	SVOA	VOA
R-20	904.6	912.2	WGR	GF0507G20R101	F	-	7/20/2005	-	-	x	-	-	-	-	x	-	x	-	-
R-20	904.6	912.2	WGR	R-20-1-10-17-06	F	-	10/17/2006	-	-	-	-	-	-	x	-	-	-	-	-
R-20	904.6	912.2	WGR	GW20-08-9007	UF	-	11/30/2007	-	-	-	-	-	-	-	-	-	-	-	x
R-20	904.6	912.2	WGR	GW20-08-9006	UF	-	11/30/2007	-	-	-	-	-	-	-	-	-	-	-	x
R-20	904.6	912.2	WGR	GW20-08-8999	UF	Field Duplicate	11/30/2007	-	-	-	-	-	-	-	-	-	-	-	x
R-20	904.6	912.2	WGR	GW20-08-9009	UF	-	11/30/2007	-	-	-	-	-	-	-	-	-	-	-	x
R-20	904.6	912.2	WGR	CAPA-08-13207	UF	-	6/21/2008	-	-	x	-	-	x	-	x	-	x	x	x
R-20	904.6	912.2	WGR	CAPA-08-13206	F	-	6/21/2008	-	-	x	-	-	-	-	x	-	-	-	-
R-20	1147.1	1154.7	WGR	GU0403G20R201	UF	-	3/10/2004	-	-	x	-	-	x	-	x	x	x	x	x
R-20	1147.1	1154.7	WGR	UU0403G20R201	UF	-	3/10/2004	-	-	-	-	-	-	-	-	-	x	-	-
R-20	1147.1	1154.7	WGR	GF0403G20R201	F	-	3/10/2004	-	-	x	-	-	-	-	x	-	-	-	-
R-20	1147.1	1154.7	WGR	HF0403G20R201	F	-	3/10/2004	-	-	x	-	-	-	-	-	-	-	-	-
R-20	1147.1	1154.7	WGR	GU0405G20R201	UF	-	5/4/2004	-	-	-	-	-	-	-	-	-	x	-	-
R-20	1147.1	1154.7	WGR	GU0405G20R202	UF	-	5/5/2004	-	-	x	-	-	x	-	x	x	x	x	x
R-20	1147.1	1154.7	WGR	UU0405G20R290	UF	-	5/5/2004	-	-	-	-	-	-	-	-	-	x	-	-
R-20	1147.1	1154.7	WGR	GF0405G20R201	F	-	5/5/2004	-	-	x	-	-	-	-	x	-	-	-	-

Table C-2.0-3 (continued)

Location ID	Top Depth (ft)	Bottom Depth (ft)	Media Description	Sample ID	Field Prep	Field QC Type	Collection Date	DIOX/FUR	DRO	GENINORG	GRO	Herb	HEXP	Isotope	Metals	Pest/PCB	RAD	SVOA	VOA
R-20	1147.1	1154.7	WGR	HF0405G20R201	F	-	5/5/2004	-	-	x	-	-	-	-	-	-	-	-	-
R-20	1147.1	1154.7	WGR	UU0409G20R201	UF	-	9/3/2004	-	-	-	-	-	-	-	-	-	x	-	-
R-20	1147.1	1154.7	WGR	GU0409G20R201	UF	-	9/3/2004	-	-	x	-	-	-	x	-	-	x	-	-
R-20	1147.1	1154.7	WGR	GU0409G20R201-1	UF	-	9/7/2004	-	-	x	-	-	x	-	-	x	-	x	x
R-20	1147.1	1154.7	WGR	GU0409G20R290-1	UF	Field Duplicate	9/7/2004	-	-	x	-	-	x	-	-	x	-	x	x
R-20	1147.1	1154.7	WGR	GF0409G20R201-1	F	-	9/7/2004	-	-	x	-	-	-	x	-	-	-	-	-
R-20	1147.1	1154.7	WGR	HF0409G20R201	F	-	9/7/2004	-	-	x	-	-	-	-	-	-	-	-	-
R-20	1147.1	1154.7	WGR	HF0409G20R290	F	Field Duplicate	9/7/2004	-	-	x	-	-	-	-	-	-	-	-	-
R-20	1147.1	1154.7	WGR	GU0411G20R201	UF	-	11/8/2004	-	-	x	-	-	x	-	x	x	x	x	x
R-20	1147.1	1154.7	WGR	GU0411G20R290	UF	Field Duplicate	11/8/2004	-	-	x	-	-	x	-	-	x	-	x	x
R-20	1147.1	1154.7	WGR	UU0411G20R201	UF	-	11/8/2004	-	-	-	-	-	-	-	-	-	x	-	-
R-20	1147.1	1154.7	WGR	GF0411G20R201	F	-	11/8/2004	-	-	x	-	-	-	x	-	-	-	-	-
R-20	1147.1	1154.7	WGR	HF0411G20R201	F	-	11/8/2004	-	-	x	-	-	-	-	-	-	-	-	-
R-20	1147.1	1154.7	WGR	HF0411G20R290	F	Field Duplicate	11/8/2004	-	-	x	-	-	-	-	-	-	-	-	-

Table C-2.0-3 (continued)

Location ID	Top Depth (ft)	Bottom Depth (ft)	Media Description	Sample ID	Field Prep	Field QC Type	Collection Date	DIOX/FUR	DRO	GENINORG	GRO	Herb	HEXP	Isotope	Metals	Pest/PCB	RAD	SVOA	VOA
R-20	1147.1	1154.7	WGR	GU0507G20R201	UF	-	7/19/2005	-	-	x	-	-	-	-	x	x	x	x	x
R-20	1147.1	1154.7	WGR	GF0507G20R201	F	-	7/19/2005	-	-	x	-	-	-	-	x	-	x	-	-
R-20	1147.1	1154.7	WGR	GW20-08-9118	UF	-	12/3/2007	-	-	-	-	-	-	-	-	-	-	-	x
R-20	1147.1	1154.7	WGR	GW20-08-9119	UF	-	12/3/2007	-	-	-	-	-	-	-	-	-	-	-	x
R-20	1147.1	1154.7	WGR	GW20-08-9122	UF	-	12/3/2007	-	-	-	-	-	-	-	-	-	-	-	x
R-20	1147.1	1154.7	WGR	GW20-08-9068	UF	Field Duplicate	12/3/2007	-	-	-	-	-	-	-	-	-	-	-	x
R-20	1147.1	1154.7	WGR	GW20-08-9121	UF	-	12/4/2007	-	-	-	-	-	-	-	-	-	-	-	x
R-20	1147.1	1154.7	WGR	CAPA-08-13210	UF	-	6/23/2008	-	-	x	-	-	x	-	x	-	-	x	x
R-20	1147.1	1154.7	WGR	CAPA-08-13209	F	-	6/23/2008	-	-	x	-	-	-	-	x	-	-	-	-
R-20	1328.8	1336.5	WGR	GU0403G20R390	UF	Field Duplicate	3/9/2004	-	-	x	-	-	x	-	-	x	-	x	x
R-20	1328.8	1336.5	WGR	UU0403G20R301	UF	-	3/9/2004	-	-	-	-	-	-	-	-	-	x	-	-
R-20	1328.8	1336.5	WGR	GF0403G20R301	F	-	3/9/2004	-	-	x	-	-	-	-	x	-	-	-	-
R-20	1328.8	1336.5	WGR	HF0403G20R301	F	-	3/9/2004	-	-	x	-	-	-	-	-	-	-	-	-
R-20	1328.8	1336.5	WGR	HF0403G20R390	F	Field Duplicate	3/9/2004	-	-	x	-	-	-	-	-	-	-	-	-
R-20	1328.8	1336.5	WGR	GU0403G20R301	UF	-	3/10/2004	-	-	x	-	-	x	-	x	x	x	x	x

Table C-2.0-3 (continued)

Location ID	Top Depth (ft)	Bottom Depth (ft)	Media Description	Sample ID	Field Prep	Field QC Type	Collection Date	DIOX/FUR	DRO	GENINORG	GRO	Herb	HEXP	Isotope	Metals	Pest/PCB	RAD	SVOA	VOA
R-20	1328.8	1336.5	WGR	GU0405G20R301	UF	-	5/4/2004	-	-	-	-	-	-	-	-	-	x	-	-
R-20	1328.8	1336.5	WGR	GU0405G20R302	UF	-	5/5/2004	-	-	x	-	-	x	-	x	x	x	x	x
R-20	1328.8	1336.5	WGR	UU0405G20R301	UF	-	5/5/2004	-	-	-	-	-	-	-	-	-	x	-	-
R-20	1328.8	1336.5	WGR	GF0405G20R301	F	-	5/5/2004	-	-	x	-	-	-	-	x	-	-	-	-
R-20	1328.8	1336.5	WGR	HF0405G20R301	F	-	5/5/2004	-	-	x	-	-	-	-	-	-	-	-	-
R-20	1328.8	1336.5	WGR	GU0409G20R301	UF	-	9/7/2004	-	-	x	-	-	x	-	x	x	x	x	x
R-20	1328.8	1336.5	WGR	UU0409G20R301	UF	-	9/7/2004	-	-	-	-	-	-	-	-	-	x	-	-
R-20	1328.8	1336.5	WGR	GF0409G20R301	F	-	9/7/2004	-	-	x	-	-	-	-	x	-	-	-	-
R-20	1328.8	1336.5	WGR	GU0411G20R301	UF	-	11/9/2004	-	-	x	-	-	x	-	x	x	x	x	x
R-20	1328.8	1336.5	WGR	UU0411G20R301	UF	-	11/9/2004	-	-	-	-	-	-	-	-	-	x	-	-
R-20	1328.8	1336.5	WGR	GF0411G20R301	F	-	11/9/2004	-	-	x	-	-	-	-	x	-	-	-	-
R-20	1328.8	1336.5	WGR	HF0411G20R301	F	-	11/9/2004	-	-	x	-	-	-	-	-	-	-	-	-
R-20	1328.8	1336.5	WGR	GU0507G20R301	UF	-	7/18/2005	-	-	x	-	-	-	-	x	x	x	x	x
R-20	1328.8	1336.5	WGR	GF0507G20R301	F	-	7/18/2005	-	-	x	-	-	-	-	x	-	x	-	-
R-20	1328.8	1336.5	WGR	R-20-3 07-21-06	F	-	7/21/2006	-	-	-	-	-	-	x	-	-	-	-	-
R-22	0	0	WGA	GW54-00-0016	UF	-	10/11/2000	-	-	-	-	-	-	x	-	-	-	-	-

Table C-2.0-3 (continued)

Location ID	Top Depth (ft)	Bottom Depth (ft)	Media Description	Sample ID	Field Prep	Field QC Type	Collection Date	DIOX/FUR	DRO	GENINORG	GRO	Herb	HEXP	Isotope	Metals	Pest/PCB	RAD	SVOA	VOA
R-22	872.3	914.2	WGR	GW22-01-0001	UF	-	3/13/2001	-	-	x	-	-	x	x	-	x	x	x	x
R-22	872.3	914.2	WGR	GW22-01-0002	F	-	3/13/2001	-	-	x	-	-	-	-	x	-	x	-	-
R-22	872.3	914.2	WGR	GW22-01-0012	UF	-	6/19/2001	-	-	x	-	-	x	x	x	x	x	x	x
R-22	872.3	914.2	WGR	GW22-01-0013	F	-	6/19/2001	-	-	x	-	-	-	-	x	-	-	-	-
R-22	872.3	914.2	WGR	GW22-01-0027	UF	-	11/30/2001	-	-	x	-	-	x	x	x	x	x	x	x
R-22	872.3	914.2	WGR	GW22-01-0028	F	-	11/30/2001	-	-	x	-	-	-	-	x	-	-	-	-
R-22	872.3	914.2	WGR	GW22-02-44961	UF	-	2/27/2002	-	-	x	-	-	x	x	x	x	x	x	x
R-22	872.3	914.2	WGR	GW22-02-44961-1	UF	-	2/27/2002	-	-	-	-	-	-	-	-	-	x	-	-
R-22	872.3	914.2	WGR	GW22-02-44962	F	-	2/27/2002	-	-	x	-	-	-	-	x	-	-	-	-
R-22	872.3	914.2	WGR	GU0207G22R101	UF	-	7/8/2002	-	-	x	-	-	-	-	x	-	x	x	x
R-22	872.3	914.2	WGR	UU0207G22R101	UF	-	7/8/2002	-	-	-	-	-	-	-	-	-	x	-	-
R-22	872.3	914.2	WGR	GU0207G22R101	F	-	7/8/2002	-	-	x	-	-	-	-	-	-	-	-	-
R-22	872.3	914.2	WGR	GU0311G22R101	UF	-	11/18/2003	-	-	x	-	-	x	-	x	x	x	x	x
R-22	872.3	914.2	WGR	UU0311G22R101	UF	-	11/18/2003	-	-	-	-	-	-	-	-	-	x	-	-
R-22	872.3	914.2	WGR	GU0311G22R101	F	-	11/18/2003	-	-	x	-	-	-	-	-	-	-	-	-
R-22	872.3	914.2	WGR	GU0406G22R101	UF	-	6/21/2004	-	-	x	-	-	-	-	x	x	x	x	x

Table C-2.0-3 (continued)

Location ID	Top Depth (ft)	Bottom Depth (ft)	Media Description	Sample ID	Field Prep	Field QC Type	Collection Date	DIOX/FUR	DRO	GENINORG	GRO	Herb	HEXP	Isotope	Metals	Pest/PCB	RAD	SVOA	VOA
R-22	872.3	914.2	WGR	UU0406G22R101	UF	-	6/21/2004	-	-	-	-	-	-	-	-	-	x	-	-
R-22	872.3	914.2	WGR	GU0406G22R101	F	-	6/21/2004	-	-	x	-	-	-	-	-	-	-	-	-
R-22	872.3	914.2	WGR	GU0506G22R101	UF	-	6/27/2005	-	-	x	-	-	-	x	x	x	x	x	x
R-22	872.3	914.2	WGR	GF0506G22R101	F	-	6/27/2005	-	-	x	-	-	-	x	-	-	x	-	-
R-22	872.3	914.2	WGR	UU0506G22R101	UF	-	6/28/2005	-	-	-	-	-	-	-	-	-	x	-	-
R-22	872.3	914.2	WGR	UU06080G22R101	UF	-	8/22/2006	-	-	-	-	-	-	-	-	-	x	-	-
R-22	872.3	914.2	WGR	UU06120G22R101	UF	-	12/6/2006	-	-	-	-	-	-	-	-	-	x	-	-
R-22	872.3	914.2	WGR	UU07030G22R101	UF	-	3/22/2007	-	-	-	-	-	-	-	-	-	x	-	-
R-22	872.3	914.2	WGR	UU07060G22R101	UF	-	7/10/2007	-	-	-	-	-	-	-	-	-	x	-	-
R-22	872.3	914.2	WGR	UU07090G22R101	UF	-	9/19/2007	-	-	-	-	-	-	-	-	-	x	-	-
R-22	872.3	914.2	WGR	GU07090G22R101	UF	-	9/19/2007	-	-	-	-	x	-	-	-	-	-	-	-
R-22	872.3	914.2	WGR	CAPA-08-13195	UF	-	6/24/2008	-	-	-	-	-	-	-	-	-	x	-	-
R-22	947	988.9	WGR	GW22-01-0003	UF	-	3/12/2001	-	-	x	-	-	x	x	x	x	x	x	x
R-22	947	988.9	WGR	GW22-01-0004	F	-	3/12/2001	-	-	x	-	-	-	-	x	-	x	-	-
R-22	947	988.9	WGR	GW22-01-0014	UF	-	6/20/2001	-	-	x	-	-	x	x	x	x	x	x	x
R-22	947	988.9	WGR	GW22-01-0015	F	-	6/20/2001	-	-	x	-	-	-	-	x	-	-	-	-

Table C-2.0-3 (continued)

Location ID	Top Depth (ft)	Bottom Depth (ft)	Media Description	Sample ID	Field Prep	Field QC Type	Collection Date	DIOX/FUR	DRO	GENINORG	GRO	Herb	HEXP	Isotope	Metals	Pest/PCB	RAD	SVOA	VOA
R-22	947	988.9	WGR	GW22-01-0029	UF	-	12/3/2001	-	-	x	-	-	x	x	x	x	x	x	x
R-22	947	988.9	WGR	GW22-01-0030	F	-	12/3/2001	-	-	x	-	-	-	-	x	-	-	-	-
R-22	947	988.9	WGR	GW22-02-44963	UF	-	2/28/2002	-	-	x	-	-	x	x	x	x	x	x	x
R-22	947	988.9	WGR	GW22-02-44963-1	UF	-	2/28/2002	-	-	-	-	-	-	-	-	-	x	-	-
R-22	947	988.9	WGR	GW22-02-44964	F	-	2/28/2002	-	-	x	-	-	-	-	x	-	-	-	-
R-22	947	988.9	WGR	GU0207G22R201	UF	-	7/11/2002	-	-	x	-	-	-	-	x	-	x	x	x
R-22	947	988.9	WGR	UU0207G22R201	UF	-	7/11/2002	-	-	-	-	-	-	-	-	-	x	-	-
R-22	947	988.9	WGR	GU0207G22R201	F	-	7/11/2002	-	-	x	-	-	-	-	-	-	-	-	-
R-22	947	988.9	WGR	GU0311G22R201	UF	-	11/19/2003	-	-	x	-	-	x	-	x	x	x	x	x
R-22	947	988.9	WGR	UU0311G22R201	UF	-	11/19/2003	-	-	-	-	-	-	-	-	-	x	-	-
R-22	947	988.9	WGR	GU0311G22R201	F	-	11/19/2003	-	-	x	-	-	-	-	-	-	-	-	-
R-22	947	988.9	WGR	GU0406G22R201	UF	-	6/22/2004	-	-	x	-	-	-	-	x	x	x	x	x
R-22	947	988.9	WGR	UU0406G22R201	UF	-	6/22/2004	-	-	-	-	-	-	-	-	-	x	-	-
R-22	947	988.9	WGR	GU0406G22R201	F	-	6/22/2004	-	-	x	-	-	-	-	-	-	-	-	-
R-22	947	988.9	WGR	GU0506G22R201	UF	-	6/28/2005	-	-	x	-	-	-	-	x	x	x	x	x
R-22	947	988.9	WGR	UU0506G22R201	UF	-	6/28/2005	-	-	-	-	-	-	-	-	-	x	-	-

Table C-2.0-3 (continued)

Location ID	Top Depth (ft)	Bottom Depth (ft)	Media Description	Sample ID	Field Prep	Field QC Type	Collection Date	DIOX/FUR	DRO	GENINORG	GRO	Herb	HEXP	Isotope	Metals	Pest/PCB	RAD	SVOA	VOA
R-22	947	988.9	WGR	GF0506G22R201	F	-	6/28/2005	-	-	x	-	-	-	-	x	-	x	-	-
R-22	947	988.9	WGR	GU06080G22R201	UF	-	8/28/2006	-	-	x	-	x	x	-	x	x	x	x	x
R-22	947	988.9	WGR	UU06080G22R201	UF	-	8/28/2006	-	-	-	-	-	-	-	-	-	x	-	-
R-22	947	988.9	WGR	GF06080G22R201	F	-	8/28/2006	-	-	x	-	-	-	-	x	-	x	-	-
R-22	947	988.9	WGR	SU06080G22R201	UF	-	8/28/2006	-	-	-	-	-	x	-	-	-	-	-	-
R-22	947	988.9	WGR	GU06080G22R201	F	-	8/28/2006	-	-	x	-	-	-	-	-	-	-	-	-
R-22	947	988.9	WGR	GU06120G22R201	UF	-	12/7/2006	-	-	x	-	-	x	-	x	x	x	x	x
R-22	947	988.9	WGR	UU06120G22R201	UF	-	12/7/2006	-	-	-	-	-	-	-	-	-	x	-	-
R-22	947	988.9	WGR	GF06120G22R201	F	-	12/7/2006	-	-	x	-	-	-	-	x	-	x	-	-
R-22	947	988.9	WGR	SU06120G22R201	UF	-	12/7/2006	-	-	-	-	-	x	-	-	-	-	-	-
R-22	947	988.9	WGR	GU06120G22R201	F	-	12/7/2006	-	-	x	-	-	-	-	-	-	-	-	-
R-22	947	988.9	WGR	GU07030G22R201	UF	-	3/19/2007	-	-	x	-	-	x	-	x	x	x	x	x
R-22	947	988.9	WGR	UU07030G22R201	UF	-	3/19/2007	-	-	-	-	-	-	-	-	-	x	-	-
R-22	947	988.9	WGR	GF07030G22R201	F	-	3/19/2007	-	-	x	-	-	-	-	x	-	x	-	-
R-22	947	988.9	WGR	SU07030G22R201	UF	-	3/19/2007	-	-	-	-	-	x	-	-	-	-	-	-
R-22	947	988.9	WGR	GU07060G22R201	UF	-	7/10/2007	-	-	x	-	-	x	-	x	x	x	x	x

Table C-2.0-3 (continued)

Location ID	Top Depth (ft)	Bottom Depth (ft)	Media Description	Sample ID	Field Prep	Field QC Type	Collection Date	DIOX/FUR	DRO	GENINORG	GRO	Herb	HEXP	Isotope	Metals	Pest/PCB	RAD	SVOA	VOA
R-22	947	988.9	WGR	UU07060G22R201	UF	-	7/10/2007	-	-	-	-	-	-	-	-	-	X	-	-
R-22	947	988.9	WGR	GF07060G22R201	F	-	7/10/2007	-	-	X	-	-	-	-	X	-	X	-	-
R-22	947	988.9	WGR	SU07060G22R201	UF	-	7/10/2007	-	-	-	-	-	X	-	-	-	-	-	-
R-22	947	988.9	WGR	GU07090G22R201	UF	-	9/18/2007	-	-	X	-	X	X	-	X	X	X	X	X
R-22	947	988.9	WGR	UU07090G22R201	UF	-	9/18/2007	-	-	-	-	-	-	-	-	-	X	-	-
R-22	947	988.9	WGR	GF07090G22R201	F	-	9/18/2007	-	-	X	-	-	-	-	X	-	X	-	-
R-22	947	988.9	WGR	SU07090G22R201	UF	-	9/18/2007	-	-	-	-	-	X	-	-	-	-	-	-
R-22	947	988.9	WGR	CAPA-08-9388	UF	-	12/17/2007	-	-	X	-	-	X	-	X	X	X	X	X
R-22	947	988.9	WGR	CAPA-08-9390	F	-	12/17/2007	-	-	X	-	-	-	-	X	-	X	-	-
R-22	947	988.9	WGR	CAPA-08-13178	UF	-	6/20/2008	-	-	X	-	-	X	-	X	X	X	X	X
R-22	947	988.9	WGR	CAPA-08-13176	F	-	6/20/2008	-	-	X	-	-	-	-	X	-	X	-	-
R-22	1272.2	1278.9	WGR	GW22-01-0005	UF	-	3/8/2001	-	-	X	-	-	X	X	X	X	X	X	X
R-22	1272.2	1278.9	WGR	GW22-01-0006	F	-	3/8/2001	-	-	X	-	-	-	-	X	-	X	-	-
R-22	1272.2	1278.9	WGR	GW22-01-0016	UF	-	6/21/2001	-	-	X	-	-	-	X	X	X	X	X	X
R-22	1272.2	1278.9	WGR	GW22-01-0022	UF	-	6/21/2001	-	-	-	-	-	-	-	-	-	X	-	-
R-22	1272.2	1278.9	WGR	GW22-01-0023	F	-	6/21/2001	-	-	-	-	-	-	-	-	-	X	-	-

Table C-2.0-3 (continued)

Location ID	Top Depth (ft)	Bottom Depth (ft)	Media Description	Sample ID	Field Prep	Field QC Type	Collection Date	DIOX/FUR	DRO	GENINORG	GRO	Herb	HEXP	Isotope	Metals	Pest/PCB	RAD	SVOA	VOA
R-22	1272.2	1278.9	WGR	GW22-01-0026	UF	-	6/27/2001	-	-	-	-	-	X	-	-	-	X	-	-
R-22	1272.2	1278.9	WGR	GW22-01-0017	F	-	6/27/2001	-	-	X	-	-	-	-	X	-	-	-	-
R-22	1272.2	1278.9	WGR	GW22-01-0017-1	F	-	6/27/2001	-	-	X	-	-	-	-	-	-	-	-	-
R-22	1272.2	1278.9	WGR	GW22-01-0031	UF	-	12/4/2001	-	-	X	-	-	X	X	X	X	X	X	X
R-22	1272.2	1278.9	WGR	GW22-01-0032	F	-	12/4/2001	-	-	X	-	-	-	-	X	-	X	-	-
R-22	1272.2	1278.9	WGR	GW22-02-44965	UF	-	3/4/2002	-	-	X	-	-	X	X	X	X	X	X	X
R-22	1272.2	1278.9	WGR	GW22-02-44965-1	UF	-	3/4/2002	-	-	-	-	-	-	-	-	-	X	-	-
R-22	1272.2	1278.9	WGR	GW22-02-44966	F	-	3/4/2002	-	-	X	-	-	-	-	X	-	-	-	-
R-22	1272.2	1278.9	WGR	GU0207G22R301	UF	-	7/9/2002	-	-	X	-	-	-	-	X	-	X	X	X
R-22	1272.2	1278.9	WGR	UU0207G22R301	UF	-	7/9/2002	-	-	-	-	-	-	-	-	-	X	-	-
R-22	1272.2	1278.9	WGR	GU0207G22R301	F	-	7/9/2002	-	-	X	-	-	-	-	-	-	-	-	-
R-22	1272.2	1278.9	WGR	GU0311G22R301	UF	-	11/20/2003	-	-	X	-	-	X	-	X	X	X	X	X
R-22	1272.2	1278.9	WGR	UU0311G22R301	UF	-	11/20/2003	-	-	-	-	-	-	-	-	-	X	-	-
R-22	1272.2	1278.9	WGR	GU0311G22R301	F	-	11/20/2003	-	-	X	-	-	-	-	-	-	-	-	-
R-22	1272.2	1278.9	WGR	GU0406G22R301	UF	-	6/23/2004	-	-	X	-	-	-	-	X	X	X	X	-
R-22	1272.2	1278.9	WGR	UU0406G22R301	UF	-	6/23/2004	-	-	-	-	-	-	-	-	-	X	-	-

Table C-2.0-3 (continued)

Location ID	Top Depth (ft)	Bottom Depth (ft)	Media Description	Sample ID	Field Prep	Field QC Type	Collection Date	DIOX/FUR	DRO	GENINORG	GRO	Herb	HEXP	Isotope	Metals	Pest/PCB	RAD	SVOA	VOA
R-22	1272.2	1278.9	WGR	GU0406G22R301	F	-	6/23/2004	-	-	x	-	-	-	-	-	-	-	-	-
R-22	1272.2	1278.9	WGR	GU0406G22R302	UF	-	6/30/2004	-	-	-	-	-	-	-	-	-	-	-	x
R-22	1272.2	1278.9	WGR	GU0506G22R301	UF	-	6/29/2005	-	-	x	-	-	-	-	x	x	x	x	x
R-22	1272.2	1278.9	WGR	GU0506G22R390	UF	Field Duplicate	6/29/2005	-	-	x	-	-	-	-	x	x	x	x	x
R-22	1272.2	1278.9	WGR	UU0506G22R301	UF	-	6/29/2005	-	-	-	-	-	-	-	-	-	x	-	-
R-22	1272.2	1278.9	WGR	UU0506G22R390	UF	Field Duplicate	6/29/2005	-	-	-	-	-	-	-	-	-	x	-	-
R-22	1272.2	1278.9	WGR	GF0506G22R301	F	-	6/29/2005	-	-	x	-	-	-	-	x	-	x	-	-
R-22	1272.2	1278.9	WGR	GF0506G22R390	F	Field Duplicate	6/29/2005	-	-	x	-	-	-	-	x	-	x	-	-
R-22	1272.2	1278.9	WGR	GU06080G22R301	UF	-	8/22/2006	-	-	x	-	x	x	-	x	x	x	x	x
R-22	1272.2	1278.9	WGR	UU06080G22R301	UF	-	8/22/2006	-	-	-	-	-	-	-	-	-	x	-	-
R-22	1272.2	1278.9	WGR	GF06080G22R301	F	-	8/22/2006	-	-	x	-	-	-	-	x	-	x	-	-
R-22	1272.2	1278.9	WGR	SU06080G22R301	UF	-	8/22/2006	-	-	-	-	-	x	-	-	-	-	-	-
R-22	1272.2	1278.9	WGR	GU06080G22R301	F	-	8/22/2006	-	-	x	-	-	-	-	-	-	-	-	-
R-22	1272.2	1278.9	WGR	GU06120G22R301	UF	-	12/8/2006	-	-	x	-	-	x	-	x	x	x	x	x
R-22	1272.2	1278.9	WGR	UU06120G22R301	UF	-	12/8/2006	-	-	-	-	-	-	-	-	-	x	-	-

Table C-2.0-3 (continued)

Location ID	Top Depth (ft)	Bottom Depth (ft)	Media Description	Sample ID	Field Prep	Field QC Type	Collection Date	DIOX/FUR	DRO	GENINORG	GRO	Herb	HEXP	Isotope	Metals	Pest/PCB	RAD	SVOA	VOA
R-22	1272.2	1278.9	WGR	GF06120G22R301	F	-	12/8/2006	-	-	x	-	-	-	-	x	-	x	-	-
R-22	1272.2	1278.9	WGR	SU06120G22R301	UF	-	12/8/2006	-	-	-	-	-	x	-	-	-	-	-	-
R-22	1272.2	1278.9	WGR	GU06120G22R301	F	-	12/8/2006	-	-	x	-	-	-	-	-	-	-	-	-
R-22	1272.2	1278.9	WGR	GU07030G22R301	UF	-	3/20/2007	-	-	x	-	-	x	-	x	x	x	x	x
R-22	1272.2	1278.9	WGR	UU07030G22R301	UF	-	3/20/2007	-	-	-	-	-	-	-	-	-	x	-	-
R-22	1272.2	1278.9	WGR	GF07030G22R301	F	-	3/20/2007	-	-	x	-	-	-	-	x	-	x	-	-
R-22	1272.2	1278.9	WGR	SU07030G22R301	UF	-	3/20/2007	-	-	-	-	-	x	-	-	-	-	-	-
R-22	1272.2	1278.9	WGR	GU07060G22R301	UF	-	7/9/2007	-	-	x	-	-	x	-	x	x	x	x	x
R-22	1272.2	1278.9	WGR	UU07060G22R301	UF	-	7/9/2007	-	-	-	-	-	-	-	-	-	x	-	-
R-22	1272.2	1278.9	WGR	GF07060G22R301	F	-	7/9/2007	-	-	x	-	-	-	-	x	-	x	-	-
R-22	1272.2	1278.9	WGR	SU07060G22R301	UF	-	7/9/2007	-	-	-	-	-	x	-	-	-	-	-	-
R-22	1272.2	1278.9	WGR	GU07090G22R301	UF	-	9/17/2007	-	-	x	-	x	-	-	x	-	-	-	x
R-22	1272.2	1278.9	WGR	UU07090G22R301	UF	-	9/17/2007	-	-	-	-	-	-	-	-	-	x	-	-
R-22	1272.2	1278.9	WGR	GF07090G22R301	F	-	9/17/2007	-	-	x	-	-	-	-	x	-	x	-	-
R-22	1272.2	1278.9	WGR	CAPA-08-13205	UF	-	6/23/2008	-	-	-	-	-	-	-	-	-	x	-	x
R-22	1378.2	1384.9	WGR	GW22-01-0007	UF	-	3/7/2001	-	-	x	-	-	x	x	-	x	x	x	x

Table C-2.0-3 (continued)

Location ID	Top Depth (ft)	Bottom Depth (ft)	Media Description	Sample ID	Field Prep	Field QC Type	Collection Date	DIOX/FUR	DRO	GENINORG	GRO	Herb	HEXP	Isotope	Metals	Pest/PCB	RAD	SVOA	VOA
R-22	1378.2	1384.9	WGR	GW22-01-0008	F	-	3/7/2001	-	-	x	-	-	-	-	x	-	x	-	-
R-22	1378.2	1384.9	WGR	GW22-01-0018	UF	-	6/25/2001	-	-	x	-	-	x	x	x	x	x	x	x
R-22	1378.2	1384.9	WGR	GW22-01-0019	F	-	6/26/2001	-	-	x	-	-	-	-	x	-	-	-	-
R-22	1378.2	1384.9	WGR	GW22-01-0019-1	F	-	6/26/2001	-	-	x	-	-	-	-	-	-	-	-	-
R-22	1378.2	1384.9	WGR	GW22-01-0033	UF	-	12/5/2001	-	-	x	-	-	x	x	x	x	x	x	x
R-22	1378.2	1384.9	WGR	GW22-01-0034	F	-	12/5/2001	-	-	x	-	-	-	-	x	-	-	-	-
R-22	1378.2	1384.9	WGR	GW22-02-44967	UF	-	3/5/2002	-	-	x	-	-	x	x	x	x	x	x	x
R-22	1378.2	1384.9	WGR	GW22-02-44971	UF	Field Duplicate	3/5/2002	-	-	x	-	-	x	x	x	x	x	x	x
R-22	1378.2	1384.9	WGR	GW22-02-44967-1	UF	-	3/5/2002	-	-	-	-	-	-	-	-	-	x	-	-
R-22	1378.2	1384.9	WGR	GW22-02-44971-1	UF	Field Duplicate	3/5/2002	-	-	-	-	-	-	-	-	-	x	-	-
R-22	1378.2	1384.9	WGR	GW22-02-44968	F	-	3/5/2002	-	-	x	-	-	-	-	x	-	-	-	-
R-22	1378.2	1384.9	WGR	GW22-02-44972	F	Field Duplicate	3/5/2002	-	-	x	-	-	-	-	x	-	-	-	-
R-22	1378.2	1384.9	WGR	GU0207G22R401	UF	-	7/11/2002	-	-	x	-	-	-	-	x	-	x	x	x
R-22	1378.2	1384.9	WGR	UU0207G22R401	UF	-	7/11/2002	-	-	-	-	-	-	-	-	-	x	-	-
R-22	1378.2	1384.9	WGR	GU0207G22R401	F	-	7/11/2002	-	-	x	-	-	-	-	-	-	-	-	-

Table C-2.0-3 (continued)

Location ID	Top Depth (ft)	Bottom Depth (ft)	Media Description	Sample ID	Field Prep	Field QC Type	Collection Date	DIOX/FUR	DRO	GENINORG	GRO	Herb	HEXP	Isotope	Metals	Pest/PCB	RAD	SVOA	VOA
R-22	1378.2	1384.9	WGR	GU0311G22R401	UF	-	11/20/2003	-	-	x	-	-	x	-	x	x	x	x	x
R-22	1378.2	1384.9	WGR	GU0311G22R401	F	-	11/20/2003	-	-	x	-	-	-	-	-	-	-	-	-
R-22	1378.2	1384.9	WGR	UU0311G22R401	UF	-	11/21/2003	-	-	-	-	-	-	-	-	-	x	-	-
R-22	1378.2	1384.9	WGR	GU0406G22R401	UF	-	6/23/2004	-	-	x	-	-	-	-	x	x	x	x	-
R-22	1378.2	1384.9	WGR	UU0406G22R401	UF	-	6/23/2004	-	-	-	-	-	-	-	-	-	x	-	-
R-22	1378.2	1384.9	WGR	GU0406G22R401	F	-	6/23/2004	-	-	x	-	-	-	-	-	-	-	-	-
R-22	1378.2	1384.9	WGR	GU0406G22R402	UF	-	6/30/2004	-	-	-	-	-	-	-	-	-	-	-	x
R-22	1378.2	1384.9	WGR	GU0506G22R401	UF	-	7/1/2005	-	-	x	-	-	-	-	x	x	x	x	x
R-22	1378.2	1384.9	WGR	UU0506G22R401	UF	-	7/1/2005	-	-	-	-	-	-	-	-	-	x	-	-
R-22	1378.2	1384.9	WGR	GF0506G22R401	F	-	7/1/2005	-	-	x	-	-	-	-	x	-	x	-	-
R-22	1378.2	1384.9	WGR	UU06080G22R401	UF	-	8/22/2006	-	-	-	-	-	-	-	-	-	x	-	-
R-22	1378.2	1384.9	WGR	UU06120G22R401	UF	-	12/8/2006	-	-	-	-	-	-	-	-	-	x	-	-
R-22	1378.2	1384.9	WGR	UU07030G22R401	UF	-	3/22/2007	-	-	-	-	-	-	-	-	-	x	-	-
R-22	1378.2	1384.9	WGR	UU07060G22R401	UF	-	7/10/2007	-	-	-	-	-	-	-	-	-	x	-	-
R-22	1378.2	1384.9	WGR	UU07090G22R401	UF	-	9/14/2007	-	-	-	-	-	-	-	-	-	x	-	-
R-22	1378.2	1384.9	WGR	GU07090G22R401	UF	-	9/14/2007	-	-	-	-	x	-	-	-	-	-	-	-

Table C-2.0-3 (continued)

Location ID	Top Depth (ft)	Bottom Depth (ft)	Media Description	Sample ID	Field Prep	Field QC Type	Collection Date	DIOX/FUR	DRO	GENINORG	GRO	Herb	HEXP	Isotope	Metals	Pest/PCB	RAD	SVOA	VOA
R-22	1378.2	1384.9	WGR	CAPA-08-13197	UF	-	6/23/2008	-	-	-	-	-	-	-	-	-	x	-	-
R-22	1447.3	1452.3	WGR	GW22-01-0009	UF	-	3/6/2001	-	-	x	-	-	x	x	x	x	x	x	x
R-22	1447.3	1452.3	WGR	GW22-01-0011	UF	-	3/6/2001	-	-	-	-	-	-	-	-	-	x	-	-
R-22	1447.3	1452.3	WGR	GW22-01-0010	F	-	3/6/2001	-	-	x	-	-	-	-	x	-	x	-	-
R-22	1447.3	1452.3	WGR	GW22-01-0020	UF	-	6/26/2001	-	-	x	-	-	x	x	x	x	x	x	x
R-22	1447.3	1452.3	WGR	GW22-01-0021	F	-	6/26/2001	-	-	x	-	-	-	-	x	-	-	-	-
R-22	1447.3	1452.3	WGR	GW22-01-0021-1	F	-	6/26/2001	-	-	x	-	-	-	-	-	-	-	-	-
R-22	1447.3	1452.3	WGR	GW22-01-0035	UF	-	12/7/2001	-	-	x	-	-	x	x	x	x	x	x	x
R-22	1447.3	1452.3	WGR	GW22-01-0037	UF	Field Duplicate	12/7/2001	-	-	x	-	-	x	x	x	x	x	x	x
R-22	1447.3	1452.3	WGR	GW22-01-0036	F	-	12/7/2001	-	-	x	-	-	-	-	x	-	-	-	-
R-22	1447.3	1452.3	WGR	GW22-01-0038	F	Field Duplicate	12/7/2001	-	-	x	-	-	-	-	x	-	-	-	-
R-22	1447.3	1452.3	WGR	GW22-02-44969	UF	-	3/7/2002	-	-	x	-	-	x	x	x	x	x	x	x
R-22	1447.3	1452.3	WGR	GW22-02-44969-1	UF	-	3/7/2002	-	-	-	-	-	-	-	-	-	x	-	-
R-22	1447.3	1452.3	WGR	GW22-02-44970	F	-	3/7/2002	-	-	x	-	-	-	-	x	-	-	-	-
R-22	1447.3	1452.3	WGR	GW22-02-45789	UF	-	5/8/2002	-	-	-	-	-	-	-	-	-	-	-	x

Table C-2.0-3 (continued)

Location ID	Top Depth (ft)	Bottom Depth (ft)	Media Description	Sample ID	Field Prep	Field QC Type	Collection Date	DIOX/FUR	DRO	GENINORG	GRO	Herb	HEXP	Isotope	Metals	Pest/PCB	RAD	SVOA	VOA
R-22	1447.3	1452.3	WGR	GU0207G22R501	UF	-	7/10/2002	-	-	x	-	-	-	-	x	-	x	x	x
R-22	1447.3	1452.3	WGR	UU0207G22R501	UF	-	7/10/2002	-	-	-	-	-	-	-	-	-	x	-	-
R-22	1447.3	1452.3	WGR	GU0207G22R501	F	-	7/10/2002	-	-	x	-	-	-	-	-	-	-	-	-
R-22	1447.3	1452.3	WGR	GU0311G22R501	UF	-	11/21/2003	-	-	x	-	-	x	-	x	x	x	x	x
R-22	1447.3	1452.3	WGR	UU0311G22R501	UF	-	11/21/2003	-	-	-	-	-	-	-	-	-	x	-	-
R-22	1447.3	1452.3	WGR	GU0311G22R501	F	-	11/21/2003	-	-	x	-	-	-	-	-	-	-	-	-
R-22	1447.3	1452.3	WGR	GU0506G22R501	UF	-	7/5/2005	-	-	x	-	-	-	-	x	x	x	x	x
R-22	1447.3	1452.3	WGR	UU0506G22R501	UF	-	7/5/2005	-	-	-	-	-	-	-	-	-	x	-	-
R-22	1447.3	1452.3	WGR	GF0506G22R501	F	-	7/5/2005	-	-	x	-	-	-	-	x	-	x	-	-
R-22	1447.3	1452.3	WGR	UU06080G22R501	UF	-	8/21/2006	-	-	-	-	-	-	-	-	-	x	-	-
R-22	1447.3	1452.3	WGR	UU06120G22R501	UF	-	12/6/2006	-	-	-	-	-	-	-	-	-	x	-	-
R-22	1447.3	1452.3	WGR	UU07030G22R501	UF	-	3/22/2007	-	-	-	-	-	-	-	-	-	x	-	-
R-22	1447.3	1452.3	WGR	UU07060G22R501	UF	-	7/10/2007	-	-	-	-	-	-	-	-	-	x	-	-
R-22	1447.3	1452.3	WGR	GU07090G22R501	UF	-	9/17/2007	-	-	-	-	x	-	-	-	-	-	x	x
R-22	1447.3	1452.3	WGR	UU07090G22R501	UF	-	9/17/2007	-	-	-	-	-	-	-	-	-	x	-	-
R-22	1447.3	1452.3	WGR	CAPA-08-9961	UF	-	12/18/2007	-	-	-	-	-	-	-	-	-	x	-	x

Table C-2.0-3 (continued)

Location ID	Top Depth (ft)	Bottom Depth (ft)	Media Description	Sample ID	Field Prep	Field QC Type	Collection Date	DIOX/FUR	DRO	GENINORG	GRO	Herb	HEXP	Isotope	Metals	Pest/PCB	RAD	SVOA	VOA
R-22	1447.3	1452.3	WGR	CAPA-08-13198	UF	-	6/23/2008	-	-	-	-	-	-	-	-	-	x	-	x
R-22	n/p	n/p	WGR	CAPA-08-9404	UF	-	12/18/2007	-	-	-	-	-	-	-	-	-	x	-	-
R-22	n/p	n/p	WGR	CAPA-08-9403	UF	-	12/18/2007	-	-	-	-	-	-	-	-	-	x	-	-
R-22	n/p	n/p	WGR	CAPA-08-9406	UF	-	12/18/2007	-	-	-	-	-	-	-	-	-	x	-	-
R-22	n/p	n/p	WGR	CAPA-08-11046	UF	-	3/4/2008	-	-	x	-	-	x	-	x	x	x	x	x
R-22	n/p	n/p	WGR	CAPA-08-11048	F	-	3/4/2008	-	-	x	-	-	-	-	x	-	x	-	-
R-22	n/p	n/p	WGR	CAPA-08-11104	UF	-	3/5/2008	-	-	-	-	-	-	-	-	-	x	-	x
R-22	n/p	n/p	WGR	CAPA-08-11088	UF	-	3/5/2008	-	-	-	-	-	-	-	-	-	x	-	x
R-22	n/p	n/p	WGR	CAPA-08-11101	UF	-	3/5/2008	-	-	-	-	-	-	-	-	-	x	-	x
R-22	n/p	n/p	WGR	CAPA-08-11085	UF	-	3/10/2008	-	-	-	-	-	-	-	-	-	x	-	x
R-23	816	873.2	WGR	GU03120GR2301	UF	-	12/17/2003	-	-	x	-	-	x	-	x	x	x	x	x
R-23	816	873.2	WGR	UU03120GR2301	UF	-	12/17/2003	-	-	-	-	-	-	-	-	-	x	-	-
R-23	816	873.2	WGR	GF03120GR2301	F	-	12/17/2003	-	-	x	-	-	-	-	x	-	-	-	-
R-23	816	873.2	WGR	HF03120GR2301	F	-	12/17/2003	-	-	x	-	-	-	-	-	-	-	-	-
R-23	816	873.2	WGR	GU04030GR2301	UF	-	3/23/2004	-	-	x	-	-	x	-	x	x	x	x	x
R-23	816	873.2	WGR	GU04030GR2390	UF	Field Duplicate	3/23/2004	-	-	x	-	-	x	-	-	x	-	x	x

Table C-2.0-3 (continued)

Location ID	Top Depth (ft)	Bottom Depth (ft)	Media Description	Sample ID	Field Prep	Field QC Type	Collection Date	DIOX/FUR	DRO	GENINORG	GRO	Herb	HEXP	Isotope	Metals	Pest/PCB	RAD	SVOA	VOA
R-23	816	873.2	WGR	UU04030GR2301	UF	-	3/23/2004	-	-	-	-	-	-	-	-	-	x	-	-
R-23	816	873.2	WGR	GF04030GR2301	F	-	3/23/2004	-	-	x	-	-	-	-	x	-	-	-	-
R-23	816	873.2	WGR	GU04060GR2301	UF	-	6/29/2004	-	-	x	-	-	x	-	x	x	x	x	x
R-23	816	873.2	WGR	UU04060GR2301	UF	-	6/29/2004	-	-	-	-	-	-	-	-	-	x	-	-
R-23	816	873.2	WGR	GF04060GR2301	F	-	6/29/2004	-	-	x	-	-	-	-	x	-	-	-	-
R-23	816	873.2	WGR	HF04060GR2301	F	-	6/29/2004	-	-	x	-	-	-	-	-	-	-	-	-
R-23	816	873.2	WGR	GU04090GR2301	UF	-	9/24/2004	-	-	x	-	-	x	-	x	x	x	x	x
R-23	816	873.2	WGR	GU04090GR2390	UF	Field Duplicate	9/24/2004	-	-	x	-	-	x	-	-	x	-	x	x
R-23	816	873.2	WGR	UU04090GR2301	UF	-	9/24/2004	-	-	-	-	-	-	-	-	-	x	-	-
R-23	816	873.2	WGR	GF04090GR2301	F	-	9/24/2004	-	-	x	-	-	-	-	x	-	-	-	-
R-23	816	873.2	WGR	HF04090GR2301	F	-	9/24/2004	-	-	x	-	-	-	-	-	-	-	-	-
R-23	816	873.2	WGR	HF04090GR2390	F	Field Duplicate	9/24/2004	-	-	x	-	-	-	-	-	-	-	-	-
R-23	816	873.2	WGR	GU05070GR2301	UF	-	7/14/2005	-	-	x	-	-	-	-	x	x	x	x	x
R-23	816	873.2	WGR	GU05070GR2390	UF	Field Duplicate	7/14/2005	-	-	x	-	-	-	-	x	x	x	x	x
R-23	816	873.2	WGR	UU05070GR2301	UF	-	7/14/2005	-	-	-	-	-	-	-	-	-	x	-	-

Table C-2.0-3 (continued)

Location ID	Top Depth (ft)	Bottom Depth (ft)	Media Description	Sample ID	Field Prep	Field QC Type	Collection Date	DIOX/FUR	DRO	GENINORG	GRO	Herb	HEXP	Isotope	Metals	Pest/PCB	RAD	SVOA	VOA
R-23	816	873.2	WGR	UU05070GR2390	UF	Field Duplicate	7/14/2005	-	-	-	-	-	-	-	-	-	x	-	-
R-23	816	873.2	WGR	GF05070GR2301	F	-	7/14/2005	-	-	x	-	-	-	-	x	-	x	-	-
R-23	816	873.2	WGR	GF05070GR2390	F	Field Duplicate	7/14/2005	-	-	x	-	-	-	-	x	-	x	-	-
R-23	816	873.2	WGR	R-23-7-14-05	F	-	7/14/2005	-	-	-	-	-	-	x	-	-	-	-	-
R-23	816	873.2	WGR	R-23-8-15-05	F	-	8/15/2005	-	-	-	-	-	-	x	-	-	-	-	-
R-23	816	873.2	WGR	GU060800GR2301	UF	-	8/15/2006	-	-	x	-	x	x	-	x	x	x	x	x
R-23	816	873.2	WGR	GU060800GR2390	UF	Field Duplicate	8/15/2006	-	-	x	-	x	x	-	x	x	x	x	x
R-23	816	873.2	WGR	UU060800GR2301	UF	-	8/15/2006	-	-	-	-	-	-	-	-	-	x	-	-
R-23	816	873.2	WGR	UU060800GR2390	UF	Field Duplicate	8/15/2006	-	-	-	-	-	-	-	-	-	x	-	-
R-23	816	873.2	WGR	GF060800GR2301	F	-	8/15/2006	-	-	x	-	-	-	-	x	-	x	-	-
R-23	816	873.2	WGR	GF060800GR2390	F	Field Duplicate	8/15/2006	-	-	x	-	-	-	-	x	-	x	-	-
R-23	816	873.2	WGR	SU060800GR2301	UF	-	8/15/2006	-	-	-	-	-	x	-	-	-	-	-	-
R-23	816	873.2	WGR	SU060800GR2390	UF	Field Duplicate	8/15/2006	-	-	-	-	-	x	-	-	-	-	-	-

Table C-2.0-3 (continued)

Location ID	Top Depth (ft)	Bottom Depth (ft)	Media Description	Sample ID	Field Prep	Field QC Type	Collection Date	DIOX/FUR	DRO	GENINORG	GRO	Herb	HEXP	Isotope	Metals	Pest/PCB	RAD	SVOA	VOA
R-23	816	873.2	WGR	GU060800GR2301	F	-	8/15/2006	-	-	x	-	-	-	-	-	-	-	-	-
R-23	816	873.2	WGR	GU060800GR2390	F	Field Duplicate	8/15/2006	-	-	x	-	-	-	-	-	-	-	-	-
R-23	816	873.2	WGR	GU061200GR2301	UF	-	12/18/2006	-	-	x	-	-	x	-	x	x	x	x	x
R-23	816	873.2	WGR	GU061200GR2320	UF	Field Duplicate	12/18/2006	-	-	x	-	-	x	-	x	x	x	x	x
R-23	816	873.2	WGR	GF061200GR2301	F	-	12/18/2006	-	-	x	-	-	-	-	x	-	x	-	-
R-23	816	873.2	WGR	GF061200GR2320	F	Field Duplicate	12/18/2006	-	-	x	-	-	-	-	x	-	x	-	-
R-23	816	873.2	WGR	SU061200GR2301	UF	-	12/18/2006	-	-	-	-	-	x	-	-	-	-	-	-
R-23	816	873.2	WGR	SU061200GR2320	UF	Field Duplicate	12/18/2006	-	-	-	-	-	x	-	-	-	-	-	-
R-23	816	873.2	WGR	GU061200GR2301	F	-	12/18/2006	-	-	x	-	-	-	-	-	-	-	-	-
R-23	816	873.2	WGR	GU061200GR2320	F	Field Duplicate	12/18/2006	-	-	x	-	-	-	-	-	-	-	-	-
R-23	816	873.2	WGR	GU070300GR2301	UF	-	3/19/2007	-	-	x	-	-	x	-	x	x	x	x	x
R-23	816	873.2	WGR	GU070300GR2320	UF	Field Duplicate	3/19/2007	-	-	x	-	-	x	-	x	x	x	x	x
R-23	816	873.2	WGR	UU070300GR2301	UF	-	3/19/2007	-	-	-	-	-	-	-	-	-	x	-	-

Table C-2.0-3 (continued)

Location ID	Top Depth (ft)	Bottom Depth (ft)	Media Description	Sample ID	Field Prep	Field QC Type	Collection Date	DIOX/FUR	DRO	GENINORG	GRO	Herb	HEXP	Isotope	Metals	Pest/PCB	RAD	SVOA	VOA
R-23	816	873.2	WGR	UU070300GR2320	UF	Field Duplicate	3/19/2007	-	-	-	-	-	-	-	-	-	x	-	-
R-23	816	873.2	WGR	GF070300GR2301	F	-	3/19/2007	-	-	x	-	-	-	-	x	-	x	-	-
R-23	816	873.2	WGR	GF070300GR2320	F	Field Duplicate	3/19/2007	-	-	x	-	-	-	-	x	-	x	-	-
R-23	816	873.2	WGR	SU070300GR2301	UF	-	3/19/2007	-	-	-	-	-	x	-	-	-	-	-	-
R-23	816	873.2	WGR	SU070300GR2320	UF	Field Duplicate	3/19/2007	-	-	-	-	-	x	-	-	-	-	-	-
R-23	816	873.2	WGR	GU070600GR2301	UF	-	6/25/2007	-	-	x	-	-	x	-	x	x	x	x	x
R-23	816	873.2	WGR	GU070600GR2320	UF	Field Duplicate	6/25/2007	-	-	x	-	-	x	-	x	x	x	x	x
R-23	816	873.2	WGR	UU070600GR2301	UF	-	6/25/2007	-	-	-	-	-	-	-	-	-	x	-	-
R-23	816	873.2	WGR	UU070600GR2320	UF	Field Duplicate	6/25/2007	-	-	-	-	-	-	-	-	-	x	-	-
R-23	816	873.2	WGR	GF070600GR2301	F	-	6/25/2007	-	-	x	-	-	-	-	x	-	x	-	-
R-23	816	873.2	WGR	GF070600GR2320	F	Field Duplicate	6/25/2007	-	-	x	-	-	-	-	x	-	x	-	-
R-23	816	873.2	WGR	SU070600GR2301	UF	-	6/25/2007	-	-	-	-	-	x	-	-	-	-	-	-
R-23	816	873.2	WGR	SU070600GR2320	UF	Field	6/25/2007	-	-	-	-	-	x	-	-	-	-	-	-

Table C-2.0-3 (continued)

Location ID	Top Depth (ft)	Bottom Depth (ft)	Media Description	Sample ID	Field Prep	Field QC Type	Collection Date	DIOX/FUR	DRO	GENINORG	GRO	Herb	HEXP	Isotope	Metals	Pest/PCB	RAD	SVOA	VOA
						Duplicate													
R-23	816	873.2	WGR	GU070900GR2301	UF	-	9/6/2007	-	-	x	-	x	x	-	x	x	x	x	x
R-23	816	873.2	WGR	GU070900GR2320	UF	Field Duplicate	9/6/2007	-	-	x	-	x	x	-	x	x	x	x	x
R-23	816	873.2	WGR	UU070900GR2301	UF	-	9/6/2007	-	-	-	-	-	-	-	-	-	x	-	-
R-23	816	873.2	WGR	UU070900GR2320	UF	Field Duplicate	9/6/2007	-	-	-	-	-	-	-	-	-	x	-	-
R-23	816	873.2	WGR	GF070900GR2301	F	-	9/6/2007	-	-	x	-	-	-	-	x	-	x	-	-
R-23	816	873.2	WGR	GF070900GR2320	F	Field Duplicate	9/6/2007	-	-	x	-	-	-	-	x	-	x	-	-
R-23	816	873.2	WGR	SU070900GR2301	UF	-	9/6/2007	-	-	-	-	-	x	-	-	-	-	-	-
R-23	816	873.2	WGR	SU070900GR2320	UF	Field Duplicate	9/6/2007	-	-	-	-	-	x	-	-	-	-	-	-
R-23	816	873.2	WGR	CAPA-08-9335	UF	-	12/6/2007	-	-	x	-	-	x	-	x	x	x	x	x
R-23	816	873.2	WGR	CAPA-08-9336	F	-	12/6/2007	-	-	x	-	-	-	-	x	-	x	-	-
R-23	816	873.2	WGR	CAPA-08-13182	UF	-	6/9/2008	-	-	x	-	-	x	-	x	x	x	x	x
R-23	816	873.2	WGR	CAPA-08-13181	F	-	6/9/2008	-	-	x	-	-	-	-	x	-	x	-	-
R-23	n/p	n/p	WGR	CAPA-08-11054	UF	-	3/4/2008	-	-	x	-	-	x	-	x	x	x	x	x

Table C-2.0-3 (continued)

Location ID	Top Depth (ft)	Bottom Depth (ft)	Media Description	Sample ID	Field Prep	Field QC Type	Collection Date	DIOX/FUR	DRO	GENINORG	GRO	Herb	HEXP	Isotope	Metals	Pest/PCB	RAD	SVOA	VOA
R-23	n/p	n/p	WGR	CAPA-08-11052	F	-	3/4/2008	-	-	x	-	-	-	-	x	-	x	-	-
R-23i	400.3	420	WGI	GU0709GR23I 01	UF	-	9/6/2007	-	-	x	-	x	x	-	x	x	x	x	x
R-23i	400.3	420	WGI	GU0709GR23I 20	UF	Field Duplicate	9/6/2007	-	-	x	-	x	x	-	x	x	x	x	x
R-23i	400.3	420	WGI	UU0709GR23I 01	UF	-	9/6/2007	-	-	-	-	-	-	-	-	-	x	-	-
R-23i	400.3	420	WGI	UU0709GR23I 20	UF	Field Duplicate	9/6/2007	-	-	-	-	-	-	-	-	-	x	-	-
R-23i	400.3	420	WGI	GF0709GR23I 01	F	-	9/6/2007	-	-	x	-	-	-	-	x	-	x	-	-
R-23i	400.3	420	WGI	GF0709GR23I 20	F	Field Duplicate	9/6/2007	-	-	x	-	-	-	-	x	-	x	-	-
R-23i	400.3	420	WGI	SU0709GR23I 01	UF	-	9/6/2007	-	-	-	-	-	x	-	-	-	-	-	-
R-23i	400.3	420	WGI	SU0709GR23I 20	UF	Field Duplicate	9/6/2007	-	-	-	-	-	x	-	-	-	-	-	-
R-23i	470.2	480.1	WGI	GU0609GR23I 02	UF	-	10/3/2006	-	x	x	-	-	x	-	x	x	x	x	x
R-23i	470.2	480.1	WGI	GU0609GR23I 91	UF	Field Duplicate	10/3/2006	-	x	x	-	-	x	-	x	x	x	x	x
R-23i	470.2	480.1	WGI	UU0609GR23I 02	UF	-	10/3/2006	-	-	-	-	-	-	-	-	-	x	-	-
R-23i	470.2	480.1	WGI	UU0609GR23I 91	UF	Field Duplicate	10/3/2006	-	-	-	-	-	-	-	-	-	x	-	-

Table C-2.0-3 (continued)

Location ID	Top Depth (ft)	Bottom Depth (ft)	Media Description	Sample ID	Field Prep	Field QC Type	Collection Date	DIOX/FUR	DRO	GENINORG	GRO	Herb	HEXP	Isotope	Metals	Pest/PCB	RAD	SVOA	VOA
R-23i	470.2	480.1	WGI	GF0609GR23I 02	F	-	10/3/2006	-	-	x	-	-	-	-	x	-	x	-	-
R-23i	470.2	480.1	WGI	GF0609GR23I 91	F	Field Duplicate	10/3/2006	-	-	x	-	-	-	-	x	-	x	-	-
R-23i	470.2	480.1	WGI	SF0609GR23I 02	F	-	10/3/2006	-	-	-	-	-	-	-	x	-	-	-	-
R-23i	470.2	480.1	WGI	SF0609GR23I 91	F	Field Duplicate	10/3/2006	-	-	-	-	-	-	-	x	-	-	-	-
R-23i	470.2	480.1	WGI	SU0609GR23I 02	UF	-	10/3/2006	-	-	-	-	-	x	-	-	-	-	-	-
R-23i	470.2	480.1	WGI	SU0609GR23I 91	UF	Field Duplicate	10/3/2006	-	-	-	-	-	x	-	-	-	-	-	-
R-23i	470.2	480.1	WGI	R-23i-1-11-3-06	F	-	10/11/2006	-	-	-	-	-	-	x	-	-	-	-	-
R-23i	470.2	480.1	WGI	GU0702GR23I 01	UF	-	2/28/2007	-	-	x	-	-	x	-	x	x	x	x	x
R-23i	470.2	480.1	WGI	UU0702GR23I 01	UF	-	2/28/2007	-	-	-	-	-	-	-	-	-	x	-	-
R-23i	470.2	480.1	WGI	GF0702GR23I 01	F	-	2/28/2007	-	-	x	-	-	-	-	x	-	x	-	-
R-23i	470.2	480.1	WGI	SU0702GR23I01	UF	-	2/28/2007	-	-	-	-	-	x	-	-	-	-	-	-
R-23i	470.2	480.1	WGI	GU0704GR23I 01	UF	-	4/24/2007	-	-	x	-	-	x	-	x	x	x	x	x
R-23i	470.2	480.1	WGI	GF0704GR23I 01	F	-	4/24/2007	-	-	x	-	-	-	-	x	-	x	-	-
R-23i	470.2	480.1	WGI	SU0704GR23I 01	UF	-	4/24/2007	-	-	-	-	-	x	-	-	-	-	-	-
R-23i	470.2	480.1	WGI	GU0706GR23I 01	UF	-	6/20/2007	-	-	x	-	-	x	-	x	x	x	x	x

Table C-2.0-3 (continued)

Location ID	Top Depth (ft)	Bottom Depth (ft)	Media Description	Sample ID	Field Prep	Field QC Type	Collection Date	DIOX/FUR	DRO	GENINORG	GRO	Herb	HEXP	Isotope	Metals	Pest/PCB	RAD	SVOA	VOA
R-23i	470.2	480.1	WGI	UU0706GR23I 01	UF	-	6/20/2007	-	-	-	-	-	-	-	-	-	x	-	-
R-23i	470.2	480.1	WGI	GF0706GR23I 01	F	-	6/20/2007	-	-	x	-	-	-	-	x	-	x	-	-
R-23i	470.2	480.1	WGI	SU0706GR23I 01	UF	-	6/20/2007	-	-	-	-	-	x	-	-	-	-	-	-
R-23i	470.2	480.1	WGI	CAPA-08-9378	UF	-	12/19/2007	-	-	x	-	x	x	-	x	x	x	x	x
R-23i	470.2	480.1	WGI	CAPA-08-9374	F	-	12/19/2007	-	-	x	-	-	-	-	x	-	x	-	-
R-23i	470.2	480.1	WGI	CAPA-08-13150	UF	-	6/11/2008	-	-	x	-	-	x	-	x	x	x	x	x
R-23i	470.2	480.1	WGI	CAPA-08-13149	F	-	6/11/2008	-	-	x	-	-	-	-	x	-	x	-	-
R-23i	524	547	WGI	R-23i-2-10-03-06	F	-	10/3/2006	-	-	-	-	-	-	x	-	-	-	-	-
R-23i	524	547	WGI	GU0609GR23I 03	UF	-	10/11/2006	-	x	x	-	-	x	-	x	x	x	x	x
R-23i	524	547	WGI	UU0609GR23I 03	UF	-	10/11/2006	-	-	-	-	-	-	-	-	-	x	-	-
R-23i	524	547	WGI	GF0609GR23I 03	F	-	10/11/2006	-	-	x	-	-	-	-	x	-	x	-	-
R-23i	524	547	WGI	SF0609GR23I 03	F	-	10/11/2006	-	-	-	-	-	-	-	x	-	-	-	-
R-23i	524	547	WGI	SU0609GR23I 03	UF	-	10/11/2006	-	-	-	-	-	x	-	-	-	-	-	-
R-23i	524	547	WGI	GU0702GR23I 02	UF	-	2/26/2007	-	-	x	-	-	x	-	x	x	x	x	x
R-23i	524	547	WGI	GU0702GR23I 21	UF	Field Duplicate	2/26/2007	-	-	x	-	-	x	-	x	x	x	x	x
R-23i	524	547	WGI	UU0702GR23I 02	UF	-	2/26/2007	-	-	-	-	-	-	-	-	-	x	-	-

Table C-2.0-3 (continued)

Location ID	Top Depth (ft)	Bottom Depth (ft)	Media Description	Sample ID	Field Prep	Field QC Type	Collection Date	DIOX/FUR	DRO	GENINORG	GRO	Herb	HEXP	Isotope	Metals	Pest/PCB	RAD	SVOA	VOA
R-23i	524	547	WGI	UU0702GR23I 21	UF	Field Duplicate	2/26/2007	-	-	-	-	-	-	-	-	-	x	-	-
R-23i	524	547	WGI	GF0702GR23I 02	F	-	2/26/2007	-	-	x	-	-	-	-	x	-	x	-	-
R-23i	524	547	WGI	GF0702GR23I 21	F	Field Duplicate	2/26/2007	-	-	x	-	-	-	-	x	-	-	-	-
R-23i	524	547	WGI	SU0702GR23I02	UF	-	2/26/2007	-	-	-	-	-	x	-	-	-	-	-	-
R-23i	524	547	WGI	SU0702GR23I21	UF	Field Duplicate	2/26/2007	-	-	-	-	-	x	-	-	-	-	-	-
R-23i	524	547	WGI	GU0704GR23I 02	UF	-	4/23/2007	-	-	x	-	-	x	-	x	x	x	x	x
R-23i	524	547	WGI	UU0704GR23I 02	UF	-	4/23/2007	-	-	-	-	-	-	-	-	-	x	-	-
R-23i	524	547	WGI	GF0704GR23I 02	F	-	4/23/2007	-	-	x	-	-	-	-	x	-	x	-	-
R-23i	524	547	WGI	SU0704GR23I 02	UF	-	4/23/2007	-	-	-	-	-	x	-	-	-	-	-	-
R-23i	524	547	WGI	GU0706GR23I 02	UF	-	6/20/2007	-	-	x	-	-	x	-	x	x	x	x	x
R-23i	524	547	WGI	UU0706GR23I 02	UF	-	6/20/2007	-	-	-	-	-	-	-	-	-	x	-	-
R-23i	524	547	WGI	GF0706GR23I 02	F	-	6/20/2007	-	-	x	-	-	-	-	x	-	x	-	-
R-23i	524	547	WGI	UU0709GR23I 02	UF	-	9/7/2007	-	-	-	-	-	-	-	-	-	x	-	-
R-23i	524	547	WGI	GF0709GR23I 02	F	-	9/7/2007	-	-	x	-	-	-	-	-	-	-	-	-
R-23i	524	547	WGI	CAPA-08-13158	UF	-	6/11/2008	-	-	-	-	-	-	-	-	-	x	-	-

Table C-2.0-3 (continued)

Location ID	Top Depth (ft)	Bottom Depth (ft)	Media Description	Sample ID	Field Prep	Field QC Type	Collection Date	DIOX/FUR	DRO	GENINORG	GRO	Herb	HEXP	Isotope	Metals	Pest/PCB	RAD	SVOA	VOA
R-23i	n/p	n/p	WGI	CAPA-08-11023	UF	-	3/14/2008	-	-	x	-	-	x	-	x	x	x	x	x
R-23i	n/p	n/p	WGI	CAPA-08-11024	F	-	3/14/2008	-	-	x	-	-	-	-	x	-	x	-	-
R-23i	n/p	n/p	WGI	CAPA-08-11062	F	-	3/14/2008	-	-	x	-	-	-	-	-	-	-	-	-
R-23i	n/p	n/p	WGI	CAPA-08-11063	UF	-	3/14/2008	-	-	-	-	x	-	-	-	-	x	-	x
R-32	867.5	875.2	WGR	GU0402G32R101	UF	-	3/1/2004	-	-	x	-	-	x	-	x	x	x	x	x
R-32	867.5	875.2	WGR	UU0402G32R101	UF	-	3/1/2004	-	-	-	-	-	-	-	-	-	x	-	-
R-32	867.5	875.2	WGR	GF0402G32R101	F	-	3/1/2004	-	-	x	-	-	-	-	x	-	-	-	-
R-32	867.5	875.2	WGR	HF0402G32R101	F	-	3/1/2004	-	-	x	-	-	-	-	-	-	-	-	-
R-32	867.5	875.2	WGR	GU0405G32R101	UF	-	5/5/2004	-	-	x	-	-	x	-	x	x	x	x	x
R-32	867.5	875.2	WGR	UU0405G32R101	UF	-	5/5/2004	-	-	-	-	-	-	-	-	-	x	-	-
R-32	867.5	875.2	WGR	GF0405G32R101	F	-	5/5/2004	-	-	x	-	-	-	-	x	-	-	-	-
R-32	867.5	875.2	WGR	HF0405G32R101	F	-	5/5/2004	-	-	x	-	-	-	-	-	-	-	-	-
R-32	867.5	875.2	WGR	GU0409G32R101	UF	-	9/21/2004	-	-	x	-	-	x	-	x	x	x	x	x
R-32	867.5	875.2	WGR	UU0409G32R101	UF	-	9/21/2004	-	-	-	-	-	-	-	-	-	x	-	-
R-32	867.5	875.2	WGR	GF0409G32R101	F	-	9/21/2004	-	-	x	-	-	-	-	x	-	-	-	-
R-32	867.5	875.2	WGR	GU0411G32R101	UF	-	11/15/2004	-	-	x	-	-	x	-	x	x	x	x	x

Table C-2.0-3 (continued)

Location ID	Top Depth (ft)	Bottom Depth (ft)	Media Description	Sample ID	Field Prep	Field QC Type	Collection Date	DIOX/FUR	DRO	GENINORG	GRO	Herb	HEXP	Isotope	Metals	Pest/PCB	RAD	SVOA	VOA
R-32	867.5	875.2	WGR	GF0411G32R101	F	-	11/15/2004	-	-	x	-	-	-	-	x	-	-	-	-
R-32	867.5	875.2	WGR	UU0411G32R101	UF	-	11/15/2004	-	-	-	-	-	-	-	-	-	x	-	-
R-32	867.5	875.2	WGR	HF0411G32R101	F	-	11/15/2004	-	-	x	-	-	-	-	-	-	-	-	-
R-32	867.5	875.2	WGR	GU0506G32R101	UF	-	6/22/2005	-	-	x	-	-	-	-	x	x	x	x	x
R-32	867.5	875.2	WGR	GF0506G32R101	F	-	6/22/2005	-	-	x	-	-	-	-	x	-	x	-	-
R-32	867.5	875.2	WGR	GU06080G32R101	UF	-	8/29/2006	-	-	x	-	x	x	-	x	x	x	x	x
R-32	867.5	875.2	WGR	UU06080G32R101	UF	-	8/29/2006	-	-	-	-	-	-	-	-	-	x	-	-
R-32	867.5	875.2	WGR	GF06080G32R101	F	-	8/29/2006	-	-	x	-	-	-	-	x	-	x	-	-
R-32	867.5	875.2	WGR	SU06080G32R101	UF	-	8/29/2006	-	-	-	-	-	x	-	-	-	-	-	-
R-32	867.5	875.2	WGR	GU06080G32R101	F	-	8/29/2006	-	-	x	-	-	-	-	-	-	-	-	-
R-32	867.5	875.2	WGR	GU06120G32R101	UF	-	12/12/2006	-	-	x	-	-	x	-	x	x	x	x	x
R-32	867.5	875.2	WGR	GF06120G32R101	F	-	12/12/2006	-	-	x	-	-	-	-	x	-	x	-	-
R-32	867.5	875.2	WGR	SU06120G32R101	UF	-	12/12/2006	-	-	-	-	-	x	-	-	-	-	-	-
R-32	867.5	875.2	WGR	GU06120G32R101	F	-	12/12/2006	-	-	x	-	-	-	-	-	-	-	-	-
R-32	867.5	875.2	WGR	GU07030G32R101	UF	-	3/26/2007	-	-	x	-	-	x	-	x	x	x	x	x
R-32	867.5	875.2	WGR	UU07030G32R101	UF	-	3/26/2007	-	-	-	-	-	-	-	-	-	x	-	-

Table C-2.0-3 (continued)

Location ID	Top Depth (ft)	Bottom Depth (ft)	Media Description	Sample ID	Field Prep	Field QC Type	Collection Date	DIOX/FUR	DRO	GENINORG	GRO	Herb	HEXP	Isotope	Metals	Pest/PCB	RAD	SVOA	VOA
R-32	867.5	875.2	WGR	GF07030G32R101	F	-	3/26/2007	-	-	x	-	-	-	-	x	-	x	-	-
R-32	867.5	875.2	WGR	SU07030G32R101	UF	-	3/26/2007	-	-	-	-	-	x	-	-	-	-	-	-
R-32	867.5	875.2	WGR	GU07060G32R101	UF	-	7/5/2007	-	-	x	-	-	x	-	x	x	x	x	x
R-32	867.5	875.2	WGR	UU07060G32R101	UF	-	7/5/2007	-	-	-	-	-	-	-	-	-	x	-	-
R-32	867.5	875.2	WGR	GF07060G32R101	F	-	7/5/2007	-	-	x	-	-	-	-	x	-	x	-	-
R-32	867.5	875.2	WGR	SU07060G32R101	UF	-	7/5/2007	-	-	-	-	-	x	-	-	-	-	-	-
R-32	867.5	875.2	WGR	CAPA-08-9338	UF	-	12/14/2007	-	-	x	-	-	x	-	x	x	x	x	x
R-32	867.5	875.2	WGR	CAPA-08-9720	UF	Field Duplicate	12/14/2007	-	-	x	-	-	x	-	x	x	x	x	x
R-32	867.5	875.2	WGR	CAPA-08-9339	F	-	12/14/2007	-	-	x	-	-	-	-	x	-	x	-	-
R-32	867.5	875.2	WGR	CAPA-08-9721	F	Field Duplicate	12/14/2007	-	-	x	-	-	-	-	x	-	x	-	-
R-32	867.5	875.2	WGR	CAPA-08-13184	UF	-	6/9/2008	-	-	x	-	-	x	-	x	x	x	x	x
R-32	867.5	875.2	WGR	CAPA-08-13186	UF	Field Duplicate	6/9/2008	-	-	x	-	-	x	-	x	x	x	x	x
R-32	867.5	875.2	WGR	CAPA-08-13185	F	-	6/9/2008	-	-	x	-	-	-	-	x	-	x	-	-
R-32	867.5	875.2	WGR	CAPA-08-13187	F	Field Duplicate	6/9/2008	-	-	x	-	-	-	-	x	-	x	-	-

Table C-2.0-3 (continued)

Location ID	Top Depth (ft)	Bottom Depth (ft)	Media Description	Sample ID	Field Prep	Field QC Type	Collection Date	DIOX/FUR	DRO	GENINORG	GRO	Herb	HEXP	Isotope	Metals	Pest/PCB	RAD	SVOA	VOA
R-32	972.9	980.6	WGR	GU0402G32R301	UF	-	3/3/2004	-	-	x	-	-	x	-	x	x	x	x	x
R-32	972.9	980.6	WGR	UU0402G32R301	UF	-	3/3/2004	-	-	-	-	-	-	-	-	-	x	-	-
R-32	972.9	980.6	WGR	GF0402G32R301	F	-	3/3/2004	-	-	x	-	-	-	-	x	-	-	-	-
R-32	972.9	980.6	WGR	HF0402G32R301	F	-	3/3/2004	-	-	x	-	-	-	-	-	-	-	-	-
R-32	972.9	980.6	WGR	GU0405G32R301	UF	-	5/6/2004	-	-	x	-	-	x	-	x	x	x	x	-
R-32	972.9	980.6	WGR	UU0405G32R301	UF	-	5/6/2004	-	-	-	-	-	-	-	-	-	x	-	-
R-32	972.9	980.6	WGR	GU0405G32R301-A	UF	-	5/10/2004	-	-	-	-	-	-	-	-	-	-	-	x
R-32	972.9	980.6	WGR	GF0405G32R301	F	-	5/10/2004	-	-	x	-	-	-	-	x	-	-	-	-
R-32	972.9	980.6	WGR	HF0405G32R301	F	-	5/10/2004	-	-	x	-	-	-	-	-	-	-	-	-
R-32	972.9	980.6	WGR	GU0409G32R301	UF	-	9/22/2004	-	-	x	-	-	x	-	x	x	x	x	x
R-32	972.9	980.6	WGR	UU0409G32R301	UF	-	9/22/2004	-	-	-	-	-	-	-	-	-	x	-	-
R-32	972.9	980.6	WGR	GF0409G32R301	F	-	9/22/2004	-	-	x	-	-	-	-	x	-	-	-	-
R-32	972.9	980.6	WGR	HF0409G32R301	F	-	9/22/2004	-	-	x	-	-	-	-	-	-	-	-	-
R-32	972.9	980.6	WGR	GU0411G32R301	UF	-	11/16/2004	-	-	x	-	-	x	-	x	x	x	x	x
R-32	972.9	980.6	WGR	UU0411G32R301	UF	-	11/16/2004	-	-	-	-	-	-	-	-	-	x	-	-
R-32	972.9	980.6	WGR	GF0411G32R301	F	-	11/16/2004	-	-	x	-	-	-	-	x	-	-	-	-

Table C-2.0-3 (continued)

Location ID	Top Depth (ft)	Bottom Depth (ft)	Media Description	Sample ID	Field Prep	Field QC Type	Collection Date	DIOX/FUR	DRO	GENINORG	GRO	Herb	HEXP	Isotope	Metals	Pest/PCB	RAD	SVOA	VOA
R-32	972.9	980.6	WGR	HF0411G32R301	F	-	11/16/2004	-	-	x	-	-	-	-	-	-	-	-	-
R-32	972.9	980.6	WGR	GU0506G32R301	UF	-	6/24/2005	-	-	x	-	-	-	-	x	x	x	x	x
R-32	972.9	980.6	WGR	GF0506G32R301	F	-	6/24/2005	-	-	x	-	-	-	-	x	-	x	-	-
R-32	972.9	980.6	WGR	GU06080G32R301	UF	-	8/30/2006	-	-	x	-	x	x	-	x	x	x	x	x
R-32	972.9	980.6	WGR	UU06080G32R301	UF	-	8/30/2006	-	-	-	-	-	-	-	-	-	x	-	-
R-32	972.9	980.6	WGR	GF06080G32R301	F	-	8/30/2006	-	-	x	-	-	-	-	x	-	x	-	-
R-32	972.9	980.6	WGR	SU06080G32R301	UF	-	8/30/2006	-	-	-	-	-	x	-	-	-	-	-	-
R-32	972.9	980.6	WGR	GU06080G32R301	F	-	8/30/2006	-	-	x	-	-	-	-	-	-	-	-	-
R-32	972.9	980.6	WGR	GU06120G32R301	UF	-	12/13/2006	-	-	x	-	-	x	-	x	x	x	x	x
R-32	972.9	980.6	WGR	GF06120G32R301	F	-	12/13/2006	-	-	x	-	-	-	-	x	-	x	-	-
R-32	972.9	980.6	WGR	SU06120G32R301	UF	-	12/13/2006	-	-	-	-	-	x	-	-	-	-	-	-
R-32	972.9	980.6	WGR	GU06120G32R301	F	-	12/13/2006	-	-	x	-	-	-	-	-	-	-	-	-
R-32	972.9	980.6	WGR	GU07030G32R301	UF	-	3/27/2007	-	-	x	-	-	x	-	x	x	x	x	x
R-32	972.9	980.6	WGR	UU07030G32R301	UF	-	3/27/2007	-	-	-	-	-	-	-	-	-	x	-	-
R-32	972.9	980.6	WGR	GF07030G32R301	F	-	3/27/2007	-	-	x	-	-	-	-	x	-	x	-	-
R-32	972.9	980.6	WGR	GU07060G32R301	UF	-	7/6/2007	-	-	x	-	-	x	-	x	x	x	x	x

Table C-2.0-3 (continued)

Location ID	Top Depth (ft)	Bottom Depth (ft)	Media Description	Sample ID	Field Prep	Field QC Type	Collection Date	DIOX/FUR	DRO	GENINORG	GRO	Herb	HEXP	Isotope	Metals	Pest/PCB	RAD	SVOA	VOA
R-32	972.9	980.6	WGR	UU07060G32R301	UF	-	7/6/2007	-	-	-	-	-	-	-	-	-	x	-	-
R-32	972.9	980.6	WGR	GF07060G32R301	F	-	7/6/2007	-	-	x	-	-	-	-	x	-	x	-	-
R-32	972.9	980.6	WGR	SU07060G32R301	UF	-	7/6/2007	-	-	-	-	-	x	-	-	-	-	-	-
R-32	n/p	n/p	WGR	CAPA-08-11055	UF	-	3/4/2008	-	-	x	-	x	x	-	x	x	x	x	x
R-32	n/p	n/p	WGR	CAPA-08-11056	F	-	3/4/2008	-	-	x	-	-	-	-	x	-	x	-	-
Spring 4	0	0	WGS	6706WGG4SW	UF	-	6/26/1967	-	-	x	-	-	-	-	x	-	x	-	-
Spring 4	0	0	WGS	6706WGG4SW	F	-	6/26/1967	-	-	x	-	-	-	-	-	-	-	-	-
Spring 4	0	0	WGS	6909WGG4SW	UF	-	9/16/1969	-	-	-	-	-	-	-	x	-	x	-	-
Spring 4	0	0	WGS	7010WGG4SW	UF	-	10/21/1970	-	-	-	-	-	-	-	x	-	x	-	-
Spring 4	0	0	WGS	7309WGG4SW	UF	-	9/11/1973	-	-	-	-	-	-	-	-	-	x	-	-
Spring 4	0	0	WGS	7410WGG4SW	UF	-	10/2/1974	-	-	x	-	-	-	-	x	-	-	-	-
Spring 4	0	0	WGS	7410WGG4SW	F	-	10/2/1974	-	-	x	-	-	-	-	-	-	-	-	-
Spring 4	0	0	WGS	7709WGG4SW	UF	-	9/13/1977	-	-	x	-	-	-	-	-	-	-	-	-
Spring 4	0	0	WGS	7709WGG4SW	F	-	9/13/1977	-	-	x	-	-	-	-	-	-	-	-	-
Spring 4	0	0	WGS	WG7809182891	UF	-	9/18/1978	-	-	-	-	-	-	-	x	-	x	-	-
Spring 4	0	0	WGS	WG7809192891	F	-	9/19/1978	-	-	x	-	-	-	-	x	-	-	-	-

Table C-2.0-3 (continued)

Location ID	Top Depth (ft)	Bottom Depth (ft)	Media Description	Sample ID	Field Prep	Field QC Type	Collection Date	DIOX/FUR	DRO	GENINORG	GRO	Herb	HEXP	Isotope	Metals	Pest/PCB	RAD	SVOA	VOA
Spring 4	0	0	WGS	WG7809192891	UF	-	9/19/1978	-	-	x	-	-	-	-	-	-	-	-	-
Spring 4	0	0	WGS	WG7911012891	UF	-	11/1/1979	-	-	-	-	-	-	-	x	-	x	-	-
Spring 4	0	0	WGS	WG7911142891	F	-	11/14/1979	-	-	x	-	-	-	-	x	-	-	-	-
Spring 4	0	0	WGS	WG7911142891	UF	-	11/14/1979	-	-	x	-	-	-	-	-	-	-	-	-
Spring 4	0	0	WGS	8010WGG4SW	UF	-	10/7/1980	-	-	x	-	-	-	-	x	-	x	-	-
Spring 4	0	0	WGS	8010WGG4SW	F	-	10/7/1980	-	-	x	-	-	-	-	x	-	-	-	-
Spring 4	0	0	WGS	8110WGG4SW	UF	-	10/1/1981	-	-	x	-	-	-	-	x	-	x	-	-
Spring 4	0	0	WGS	8110WGG4SW	F	-	10/1/1981	-	-	x	-	-	-	-	x	-	-	-	-
Spring 4	0	0	WGS	8209WGG4SW	UF	-	9/27/1982	-	-	x	-	-	-	-	x	-	x	-	-
Spring 4	0	0	WGS	8209WGG4SW	F	-	9/27/1982	-	-	x	-	-	-	-	x	-	-	-	-
Spring 4	0	0	WGS	8309WGG4SW	UF	-	9/20/1983	-	-	x	-	-	-	-	x	-	x	-	-
Spring 4	0	0	WGS	8309WGG4SW	F	-	9/20/1983	-	-	x	-	-	-	-	x	-	-	-	-
Spring 4	0	0	WGS	8409WGG4SW	UF	-	9/25/1984	-	-	x	-	-	-	-	x	-	x	-	-
Spring 4	0	0	WGS	8409WGG4SW	F	-	9/25/1984	-	-	x	-	-	-	-	x	-	-	-	-
Spring 4	0	0	WGS	8509WGG4SW	UF	-	9/24/1985	-	-	x	-	-	-	-	x	-	x	-	-
Spring 4	0	0	WGS	8509WGG4SW	F	-	9/24/1985	-	-	x	-	-	-	-	x	-	-	-	-

Table C-2.0-3 (continued)

Location ID	Top Depth (ft)	Bottom Depth (ft)	Media Description	Sample ID	Field Prep	Field QC Type	Collection Date	DIOX/FUR	DRO	GENINORG	GRO	Herb	HEXP	Isotope	Metals	Pest/PCB	RAD	SVOA	VOA
Spring 4	0	0	WGS	8610WGG4SW	UF	-	10/28/1986	-	-	x	-	-	-	-	x	-	x	-	-
Spring 4	0	0	WGS	8610WGG4SW	F	-	10/28/1986	-	-	x	-	-	-	-	x	-	-	-	-
Spring 4	0	0	WGS	8710WGG4SW	UF	-	10/6/1987	-	-	x	-	-	-	-	x	-	x	-	-
Spring 4	0	0	WGS	8710WGG4SW	F	-	10/6/1987	-	-	x	-	-	-	-	x	-	-	-	-
Spring 4	0	0	WGS	8801WGG4SW	UF	-	1/1/1988	-	-	x	-	-	-	-	x	-	x	-	-
Spring 4	0	0	WGS	8801WGG4SW	F	-	1/1/1988	-	-	x	-	-	-	-	x	-	-	-	-
Spring 4	0	0	WGS	8910WGG4SW	UF	-	10/6/1989	-	-	x	-	-	-	-	x	-	x	-	-
Spring 4	0	0	WGS	8910WGG4SW	F	-	10/6/1989	-	-	x	-	-	-	-	x	-	-	-	-
Spring 4	0	0	WGS	9010WGG4SW	UF	-	10/1/1990	-	-	x	-	-	-	-	x	-	x	-	-
Spring 4	0	0	WGS	9010WGG4SW	F	-	10/1/1990	-	-	x	-	-	-	-	x	-	-	-	-
Spring 4	0	0	WGS	9110WGG4SW	UF	-	10/7/1991	-	-	x	-	-	-	-	x	-	x	-	-
Spring 4	0	0	WGS	9110WGG4SW	F	-	10/7/1991	-	-	x	-	-	-	-	x	-	-	-	-
Spring 4	0	0	WGS	9209WGG4SW	UF	-	9/9/1992	-	-	x	-	-	-	-	x	-	x	-	-
Spring 4	0	0	WGS	9209WGG4SW	F	-	9/9/1992	-	-	x	-	-	-	-	x	-	-	-	-
Spring 4	0	0	WGS	9310WGG4SW	UF	-	10/12/1993	-	-	-	-	-	-	-	x	-	x	-	-
Spring 4	0	0	WGS	9310WGG4SW	F	-	10/12/1993	-	-	x	-	-	-	-	x	-	-	-	-

Table C-2.0-3 (continued)

Location ID	Top Depth (ft)	Bottom Depth (ft)	Media Description	Sample ID	Field Prep	Field QC Type	Collection Date	DIOX/FUR	DRO	GENINORG	GRO	Herb	HEXP	Isotope	Metals	Pest/PCB	RAD	SVOA	VOA
Spring 4	0	0	WGS	9409WGG4SW	UF	-	9/27/1994	-	-	-	-	-	-	-	X	-	X	-	-
Spring 4	0	0	WGS	9409WGG4SW	F	-	9/27/1994	-	-	X	-	-	-	-	X	-	-	-	-
Spring 4	0	0	WGS	9504WGG4SW	F	-	4/20/1995	-	-	X	-	-	-	-	X	-	X	-	-
Spring 4	0	0	WGS	9509WGG4SW	F	-	9/11/1995	-	-	X	-	-	-	-	-	-	-	-	-
Spring 4	0	0	WGS	9604WGG4SW	F	-	4/24/1996	-	-	X	-	-	-	-	X	-	X	-	-
Spring 4	0	0	WGS	MM96101G4SW	UF	-	10/7/1996	-	-	X	-	-	X	-	X	X	X	X	X
Spring 4	0	0	WGS	MM96101G4SW	F	-	10/7/1996	-	-	X	-	-	-	-	X	-	X	-	-
Spring 4	0	0	WGS	MM96109G4SW	UF	-	10/7/1996	-	-	-	-	-	X	-	-	-	-	-	-
Spring 4	0	0	WGS	9610WGG4SW	F	-	10/7/1996	-	-	X	-	-	-	-	-	-	-	-	-
Spring 4	0	0	WGS	MM98091G4SW	UF	-	9/28/1998	-	-	X	-	-	X	-	X	X	X	X	-
Spring 4	0	0	WGS	MM98091G4SW	F	-	9/28/1998	-	-	X	-	-	-	-	X	-	X	-	-
Spring 4	0	0	WGS	GM00091G4SW	UF	-	9/25/2000	-	-	X	-	-	X	-	-	X	X	X	X
Spring 4	0	0	WGS	G900091G4SW	UF	-	9/25/2000	-	-	-	-	-	-	-	-	X	-	-	X
Spring 4	0	0	WGS	GM00091G4SW	F	-	9/25/2000	-	-	X	-	-	-	-	X	-	X	-	-
Spring 4	0	0	WGS	GU01091G4SW-19	UF	-	9/24/2001	-	-	-	-	-	-	-	-	X	-	X	X
Spring 4	0	0	WGS	GU01091G4SW	UF	-	9/24/2001	-	-	X	-	-	X	-	X	X	X	X	X

Table C-2.0-3 (continued)

Location ID	Top Depth (ft)	Bottom Depth (ft)	Media Description	Sample ID	Field Prep	Field QC Type	Collection Date	DIOX/FUR	DRO	GENINORG	GRO	Herb	HEXP	Isotope	Metals	Pest/PCB	RAD	SVOA	VOA
Spring 4	0	0	WGS	AU01101G4SW	UF	-	11/1/2001	-	-	x	-	-	-	-	-	-	-	-	-
Spring 4	0	0	WGS	GU01101G4SW	UF	-	11/1/2001	-	-	x	-	-	-	-	-	-	-	-	-
Spring 4	0	0	WGS	MU02011G4SW	UF	-	1/28/2002	-	-	-	-	-	-	-	-	-	x	-	-
Spring 4	0	0	WGS	MU02012G4SW	UF	-	1/28/2002	-	-	-	-	-	-	-	-	-	x	-	-
Spring 4	0	0	WGS	BU02011G4SW	UF	-	1/28/2002	-	-	x	-	-	-	-	-	-	-	-	-
Spring 4	0	0	WGS	GU02011G4SW	UF	-	1/28/2002	-	-	x	-	-	-	-	-	-	-	-	-
Spring 4	0	0	WGS	GU02012G4SW	UF	-	1/28/2002	-	-	x	-	-	-	-	-	-	-	-	-
Spring 4	0	0	WGS	BU02012G4SW	UF	Field Duplicate	1/28/2002	-	-	x	-	-	-	-	-	-	-	-	-
Spring 4	0	0	WGS	GU02100G4SW01	UF	-	10/17/2002	-	-	x	-	-	x	-	x	x	x	x	x
Spring 4	0	0	WGS	UU02100G4SW01	UF	-	10/17/2002	-	-	-	-	-	-	-	-	-	x	-	-
Spring 4	0	0	WGS	GF02100G4SW01	F	-	10/17/2002	-	-	x	-	-	-	x	-	x	-	-	
Spring 4	0	0	WGS	GU03080G4SW01	UF	-	10/6/2003	-	-	x	-	-	x	-	x	x	x	x	x
Spring 4	0	0	WGS	UU03080G4SW01	UF	-	10/6/2003	-	-	-	-	-	-	-	-	-	x	-	-
Spring 4	0	0	WGS	GF03080G4SW01	F	-	10/6/2003	-	-	x	-	-	-	x	-	x	-	-	
Spring 4	0	0	WGS	GU04030G4SW01	UF	-	3/5/2004	-	-	x	-	-	-	-	-	-	-	-	

Table C-2.0-3 (continued)

Location ID	Top Depth (ft)	Bottom Depth (ft)	Media Description	Sample ID	Field Prep	Field QC Type	Collection Date	DIOX/FUR	DRO	GENINORG	GRO	Herb	HEXP	Isotope	Metals	Pest/PCB	RAD	SVOA	VOA
Spring 4	0	0	WGS	GU04030G4SW90	UF	Field Duplicate	3/5/2004	-	-	x	-	-	-	-	-	-	-	-	-
Spring 4	0	0	WGS	GU04090G4SW01	UF	-	9/13/2004	-	-	x	-	-	-	-	x	-	x	-	-
Spring 4	0	0	WGS	UU04090G4SW01	UF	-	9/13/2004	-	-	-	-	-	-	-	-	-	x	-	-
Spring 4	0	0	WGS	GF04090G4SW01	F	-	9/13/2004	-	-	x	-	-	-	-	x	-	x	-	-
Spring 4	0	0	WGS	Spr 4-7-27-05	F	-	7/27/2005	-	-	-	-	-	-	x	-	-	-	-	-
Spring 4	0	0	WGS	GU05090G4SW02	UF	-	9/26/2005	-	-	-	-	-	-	-	-	x	-	x	x
Spring 4	0	0	WGS	GF05090G4SW01	F	-	9/26/2005	-	-	x	-	-	-	-	x	-	x	-	-
Spring 4	0	0	WGS	GU05090G4SW01	UF	-	9/26/2005	-	-	x	-	-	-	-	x	-	x	-	-
Spring 4	0	0	WGS	Spr 4-9-26-05	F	-	9/26/2005	-	-	-	-	-	-	x	-	-	-	-	-
Spring 4	0	0	WGS	GU060900G4SW02	UF	-	9/18/2006	-	-	x	-	-	x	-	-	x	-	x	x
Spring 4	0	0	WGS	UU060900G4SW01	UF	-	9/18/2006	-	-	-	-	-	-	-	-	-	x	-	-
Spring 4	0	0	WGS	GF060900G4SW01	F	-	9/18/2006	-	-	x	-	-	-	-	x	-	x	-	-
Spring 4	0	0	WGS	GU060900G4SW01	UF	-	9/18/2006	-	-	x	-	-	-	-	x	-	x	-	-
Spring 4	0	0	WGS	SU060900G4SW01	UF	-	9/18/2006	-	-	-	-	-	x	-	-	-	-	-	-
Spring 4	0	0	WGS	GU060900G4SW01	F	-	9/18/2006	-	-	x	-	-	-	-	-	-	-	-	-
Spring 4	0	0	WGS	GU070400G4SW01	UF	-	5/3/2007	-	-	x	-	-	x	-	x	-	-	x	x

Table C-2.0-3 (continued)

Location ID	Top Depth (ft)	Bottom Depth (ft)	Media Description	Sample ID	Field Prep	Field QC Type	Collection Date	DIOX/FUR	DRO	GENINORG	GRO	Herb	HEXP	Isotope	Metals	Pest/PCB	RAD	SVOA	VOA
Spring 4	0	0	WGS	GU070400G4SW20	UF	Field Duplicate	5/3/2007	-	-	x	-	-	x	-	x	-	-	x	x
Spring 4	0	0	WGS	UU070400G4SW01	UF	-	5/3/2007	-	-	-	-	-	-	-	-	-	x	-	-
Spring 4	0	0	WGS	UU070400G4SW20	UF	Field Duplicate	5/3/2007	-	-	-	-	-	-	-	-	-	x	-	-
Spring 4	0	0	WGS	GF070400G4SW01	F	-	5/3/2007	-	-	x	-	-	-	-	x	-	-	-	-
Spring 4	0	0	WGS	GF070400G4SW20	F	Field Duplicate	5/3/2007	-	-	x	-	-	-	-	x	-	-	-	-
Spring 4	0	0	WGS	SU070400G4SW01	UF	-	5/3/2007	-	-	-	-	-	x	-	-	-	-	-	-
Spring 4	0	0	WGS	SU070400G4SW20	UF	Field Duplicate	5/3/2007	-	-	-	-	-	x	-	-	-	-	-	-
Spring 4	0	0	WGS	GU070900G4SW02	UF	-	9/24/2007	-	-	-	-	-	x	-	-	x	-	x	x
Spring 4	0	0	WGS	SU070900G4SW01	UF	-	9/24/2007	-	-	-	-	-	x	-	-	-	-	-	-
Spring 4	0	0	WGS	UU070900G4SW01	UF	-	9/24/2007	-	-	-	-	-	-	-	-	-	x	-	-
Spring 4	0	0	WGS	GU070900G4SW01	UF	-	9/24/2007	-	-	x	-	-	-	-	x	-	x	-	-
Spring 4	0	0	WGS	GF070900G4SW01	F	-	9/24/2007	-	-	x	-	-	-	-	x	-	x	-	-
Spring 4	0	0	WGS	CAWR-08-12099	UF	-	4/24/2008	-	-	x	-	-	x	-	x	-	x	x	x
Spring 4	0	0	WGS	CAWR-08-12101	F	-	4/24/2008	-	-	x	-	-	-	-	x	-	-	-	-

Table C-2.0-3 (continued)

Location ID	Top Depth (ft)	Bottom Depth (ft)	Media Description	Sample ID	Field Prep	Field QC Type	Collection Date	DIOX/FUR	DRO	GENINORG	GRO	Herb	HEXP	Isotope	Metals	Pest/PCB	RAD	SVOA	VOA
Spring 4A	0	0	WGS	6106WGGA4S	UF	-	6/7/1961	-	-	x	-	-	-	-	-	-	-	-	-
Spring 4A	0	0	WGS	WG6506072901	UF	-	6/7/1965	-	-	x	-	-	-	-	x	-	x	-	-
Spring 4A	0	0	WGS	WG6506072901	F	-	6/7/1965	-	-	x	-	-	-	-	x	-	-	-	-
Spring 4A	0	0	WGS	WG6506082901	UF	-	6/8/1965	-	-	x	-	-	-	-	x	-	x	-	-
Spring 4A	0	0	WGS	WG6506082901	F	-	6/8/1965	-	-	x	-	-	-	-	-	-	-	-	-
Spring 4A	0	0	WGS	6703WGGA4S	UF	-	3/3/1967	-	-	x	-	-	-	-	x	-	x	-	-
Spring 4A	0	0	WGS	6703WGGA4S	F	-	3/3/1967	-	-	x	-	-	-	-	-	-	-	-	-
Spring 4A	0	0	WGS	6706WGGA4S	UF	-	6/26/1967	-	-	x	-	-	-	-	x	-	x	-	-
Spring 4A	0	0	WGS	6706WGGA4S	F	-	6/26/1967	-	-	x	-	-	-	-	-	-	-	-	-
Spring 4A	0	0	WGS	6909WGGA4S	UF	-	9/17/1969	-	-	-	-	-	-	-	x	-	x	-	-
Spring 4A	0	0	WGS	7010WGGA4S	UF	-	10/21/1970	-	-	-	-	-	-	-	x	-	x	-	-
Spring 4A	0	0	WGS	7303WGGA4S	UF	-	3/18/1973	-	-	-	-	-	-	-	-	-	x	-	-
Spring 4A	0	0	WGS	7304WGGA4S	UF	-	4/25/1973	-	-	-	-	-	-	-	x	-	x	-	-
Spring 4A	0	0	WGS	7309WGGA4S	UF	-	9/11/1973	-	-	-	-	-	-	-	-	-	x	-	-
Spring 4A	0	0	WGS	7410WGGA4S	UF	-	10/2/1974	-	-	x	-	-	-	-	x	-	-	-	-
Spring 4A	0	0	WGS	7410WGGA4S	F	-	10/2/1974	-	-	x	-	-	-	-	-	-	-	-	-

Table C-2.0-3 (continued)

Location ID	Top Depth (ft)	Bottom Depth (ft)	Media Description	Sample ID	Field Prep	Field QC Type	Collection Date	DIOX/FUR	DRO	GENINORG	GRO	Herb	HEXP	Isotope	Metals	Pest/PCB	RAD	SVOA	VOA
Spring 4A	0	0	WGS	7709WGGA4S	UF	-	9/10/1977	-	-	x	-	-	-	-	-	-	-	-	-
Spring 4A	0	0	WGS	7709WGGA4S	F	-	9/10/1977	-	-	x	-	-	-	-	-	-	-	-	-
Spring 4A	0	0	WGS	WG7809182901	UF	-	9/18/1978	-	-	-	-	-	-	x	-	x	-	-	
Spring 4A	0	0	WGS	WG7809192901	F	-	9/19/1978	-	-	x	-	-	-	x	-	-	-	-	
Spring 4A	0	0	WGS	WG7809192901	UF	-	9/19/1978	-	-	x	-	-	-	-	-	-	-	-	
Spring 4A	0	0	WGS	WG7911012901	UF	-	11/1/1979	-	-	-	-	-	-	x	-	x	-	-	
Spring 4A	0	0	WGS	WG7911142901	F	-	11/14/1979	-	-	x	-	-	-	x	-	-	-	-	
Spring 4A	0	0	WGS	WG7911142901	UF	-	11/14/1979	-	-	x	-	-	-	-	-	-	-	-	
Spring 4A	0	0	WGS	8010WGGA4S	UF	-	10/7/1980	-	-	x	-	-	-	x	-	x	-	-	
Spring 4A	0	0	WGS	8010WGGA4S	F	-	10/7/1980	-	-	x	-	-	-	x	-	-	-	-	
Spring 4A	0	0	WGS	8110WGGA4S	UF	-	10/1/1981	-	-	x	-	-	-	x	-	x	-	-	
Spring 4A	0	0	WGS	8110WGGA4S	F	-	10/1/1981	-	-	x	-	-	-	x	-	-	-	-	
Spring 4A	0	0	WGS	8209WGGA4S	UF	-	9/27/1982	-	-	x	-	-	-	x	-	x	-	-	
Spring 4A	0	0	WGS	8209WGGA4S	F	-	9/27/1982	-	-	x	-	-	-	x	-	-	-	-	
Spring 4A	0	0	WGS	8309WGGA4S	UF	-	9/20/1983	-	-	x	-	-	-	x	-	x	-	-	
Spring 4A	0	0	WGS	8309WGGA4S	F	-	9/20/1983	-	-	x	-	-	-	x	-	-	-	-	

Table C-2.0-3 (continued)

Location ID	Top Depth (ft)	Bottom Depth (ft)	Media Description	Sample ID	Field Prep	Field QC Type	Collection Date	DIOX/FUR	DRO	GENINORG	GRO	Herb	HEXP	Isotope	Metals	Pest/PCB	RAD	SVOA	VOA
Spring 4A	0	0	WGS	8409WGGA4S	UF	-	9/24/1984	-	-	x	-	-	-	-	x	-	x	-	-
Spring 4A	0	0	WGS	8409WGGA4S	F	-	9/24/1984	-	-	x	-	-	-	-	x	-	-	-	-
Spring 4A	0	0	WGS	8509WGGA4S	UF	-	9/24/1985	-	-	x	-	-	-	-	x	-	x	-	-
Spring 4A	0	0	WGS	8509WGGA4S	F	-	9/24/1985	-	-	x	-	-	-	-	x	-	-	-	-
Spring 4A	0	0	WGS	8610WGGA4S	UF	-	10/28/1986	-	-	x	-	-	-	-	x	-	x	-	-
Spring 4A	0	0	WGS	8610WGGA4S	F	-	10/28/1986	-	-	x	-	-	-	-	x	-	-	-	-
Spring 4A	0	0	WGS	8710WGGA4S	UF	-	10/6/1987	-	-	x	-	-	-	-	x	-	x	-	-
Spring 4A	0	0	WGS	8710WGGA4S	F	-	10/6/1987	-	-	x	-	-	-	-	x	-	-	-	-
Spring 4A	0	0	WGS	8801WGGA4S	UF	-	1/1/1988	-	-	x	-	-	-	-	x	-	x	-	-
Spring 4A	0	0	WGS	8801WGGA4S	F	-	1/1/1988	-	-	x	-	-	-	-	x	-	-	-	-
Spring 4A	0	0	WGS	8901WGGA4S	UF	-	1/1/1989	-	-	x	-	-	-	-	x	-	x	-	-
Spring 4A	0	0	WGS	8901WGGA4S	F	-	1/1/1989	-	-	x	-	-	-	-	x	-	-	-	-
Spring 4A	0	0	WGS	9010WGGA4S	UF	-	10/1/1990	-	-	x	-	-	-	-	x	-	x	-	-
Spring 4A	0	0	WGS	9010WGGA4S	F	-	10/1/1990	-	-	x	-	-	-	-	x	-	-	-	-
Spring 4A	0	0	WGS	9110WGGA4S	UF	-	10/7/1991	-	-	x	-	-	-	-	x	-	x	-	-
Spring 4A	0	0	WGS	9110WGGA4S	F	-	10/7/1991	-	-	x	-	-	-	-	x	-	-	-	-

Table C-2.0-3 (continued)

Location ID	Top Depth (ft)	Bottom Depth (ft)	Media Description	Sample ID	Field Prep	Field QC Type	Collection Date	DIOX/FUR	DRO	GENINORG	GRO	Herb	HEXP	Isotope	Metals	Pest/PCB	RAD	SVOA	VOA
Spring 4A	0	0	WGS	9209WGGA4S	UF	-	9/9/1992	-	-	x	-	-	-	-	x	-	x	-	-
Spring 4A	0	0	WGS	9209WGGA4S	F	-	9/9/1992	-	-	x	-	-	-	-	x	-	-	-	-
Spring 4A	0	0	WGS	9310WGGA4S	UF	-	10/13/1993	-	-	-	-	-	-	-	x	-	x	-	-
Spring 4A	0	0	WGS	9310WGGA4S	F	-	10/13/1993	-	-	x	-	-	-	-	x	-	-	-	-
Spring 4A	0	0	WGS	9404WGGA4S	UF	-	4/5/1994	-	-	x	-	-	-	-	x	-	x	-	-
Spring 4A	0	0	WGS	9404WGGA4S	F	-	4/5/1994	-	-	x	-	-	-	-	x	-	-	-	-
Spring 4A	0	0	WGS	9409WGGA4S	UF	-	9/28/1994	-	-	-	-	-	-	-	x	-	x	-	-
Spring 4A	0	0	WGS	9409WGGA4S	F	-	9/28/1994	-	-	x	-	-	-	-	x	-	-	-	-
Spring 4A	0	0	WGS	9503WGGA4S	F	-	3/24/1995	-	-	x	-	-	-	-	x	-	x	-	-
Spring 4A	0	0	WGS	MNM95090104	UF	-	9/11/1995	-	-	x	-	-	-	-	x	-	x	-	-
Spring 4A	0	0	WGS	MNM95090105	UF	-	9/11/1995	-	-	x	-	-	-	-	x	-	x	-	-
Spring 4A	0	0	WGS	MNM95090104	F	-	9/11/1995	-	-	x	-	-	-	-	-	-	-	-	-
Spring 4A	0	0	WGS	MNM95090105	F	-	9/11/1995	-	-	x	-	-	-	-	-	-	-	-	-
Spring 4A	0	0	WGS	9604WGGA4S	F	-	4/24/1996	-	-	x	-	-	-	-	x	-	x	-	-
Spring 4A	0	0	WGS	MM96101GA4S	UF	-	10/8/1996	-	-	x	-	-	x	-	x	x	x	x	x
Spring 4A	0	0	WGS	9610WGGA4S	UF	-	10/8/1996	-	-	-	-	-	-	-	-	-	x	-	-

Table C-2.0-3 (continued)

Location ID	Top Depth (ft)	Bottom Depth (ft)	Media Description	Sample ID	Field Prep	Field QC Type	Collection Date	DIOX/FUR	DRO	GENINORG	GRO	Herb	HEXP	Isotope	Metals	Pest/PCB	RAD	SVOA	VOA
Spring 4A	0	0	WGS	9610WGGA4S	F	-	10/8/1996	-	-	x	-	-	-	-	-	-	x	-	-
Spring 4A	0	0	WGS	MM96101GA4S	F	-	10/8/1996	-	-	x	-	-	-	-	x	-	x	-	-
Spring 4A	0	0	WGS	9711WGGA4S	F	-	11/18/1997	-	-	x	-	-	-	-	x	-	x	-	-
Spring 4A	0	0	WGS	MM97111GA4S	UF	-	11/18/1997	-	-	x	-	-	x	-	x	-	x	-	-
Spring 4A	0	0	WGS	MM97111GA4S	F	-	11/18/1997	-	-	x	-	-	-	-	x	-	-	-	-
Spring 4A	0	0	WGS	MM98091GA4S	UF	-	9/29/1998	-	-	x	-	-	x	-	-	-	x	-	-
Spring 4A	0	0	WGS	MM98091GA4S	F	-	9/29/1998	-	-	x	-	-	-	-	x	-	x	-	-
Spring 4A	0	0	WGS	MM99091GA4S	UF	-	9/21/1999	-	-	x	-	-	x	-	x	x	x	x	x
Spring 4A	0	0	WGS	MM99091GA4S	F	-	9/21/1999	-	-	x	-	-	-	-	x	-	x	-	-
Spring 4A	0	0	WGS	GM00091GA4S	UF	-	9/25/2000	-	-	x	-	-	x	-	-	-	x	-	-
Spring 4A	0	0	WGS	GM00091GA4S	F	-	9/25/2000	-	-	x	-	-	-	-	-	-	x	-	-
Spring 4A	0	0	WGS	GF01091GA4S	F	-	9/25/2001	-	-	x	-	-	-	-	x	-	x	-	-
Spring 4A	0	0	WGS	GU01091GA4S	UF	-	9/25/2001	-	-	x	-	-	x	-	x	x	x	x	x
Spring 4A	0	0	WGS	AU01101GA4S	UF	-	11/1/2001	-	-	x	-	-	-	-	-	-	-	-	-
Spring 4A	0	0	WGS	GU01101GA4S	UF	-	11/1/2001	-	-	x	-	-	-	-	-	-	-	-	-
Spring 4A	0	0	WGS	MU02011GA4S	UF	-	1/28/2002	-	-	-	-	-	-	-	-	-	x	-	-

Table C-2.0-3 (continued)

Location ID	Top Depth (ft)	Bottom Depth (ft)	Media Description	Sample ID	Field Prep	Field QC Type	Collection Date	DIOX/FUR	DRO	GENINORG	GRO	Herb	HEXP	Isotope	Metals	Pest/PCB	RAD	SVOA	VOA
Spring 4A	0	0	WGS	BU02011GA4S	UF	-	1/28/2002	-	-	x	-	-	-	-	-	-	-	-	-
Spring 4A	0	0	WGS	GU02011GA4S	UF	-	1/28/2002	-	-	x	-	-	-	-	-	-	-	-	-
Spring 4A	0	0	WGS	GU02100GA4S01	UF	-	10/17/2002	-	-	x	-	-	x	-	-	-	x	-	-
Spring 4A	0	0	WGS	UU02100GA4S01	UF	-	10/17/2002	-	-	-	-	-	-	-	-	-	x	-	-
Spring 4A	0	0	WGS	GF02100GA4S01	F	-	10/17/2002	-	-	x	-	-	-	-	-	-	x	-	-
Spring 4A	0	0	WGS	GU03080GA4S01	UF	-	10/7/2003	-	-	x	-	-	x	-	-	-	x	-	-
Spring 4A	0	0	WGS	GF03080GA4S01	F	-	10/7/2003	-	-	x	-	-	-	-	-	-	x	-	-
Spring 4A	0	0	WGS	GU04030GA4S01	UF	-	3/5/2004	-	-	x	-	-	-	-	-	-	-	-	-
Spring 4A	0	0	WGS	GU04040GA4S01	UF	-	4/15/2004	-	-	x	-	-	x	-	x	x	x	x	x
Spring 4A	0	0	WGS	GF04040GA4S01	F	-	4/15/2004	-	-	x	-	-	-	x	-	-	x	-	-
Spring 4A	0	0	WGS	GU04090GA4S02	UF	-	9/14/2004	-	-	-	-	-	x	-	-	x	-	x	x
Spring 4A	0	0	WGS	GU04090GA4S01	UF	-	9/14/2004	-	-	x	-	-	-	-	x	-	x	-	-
Spring 4A	0	0	WGS	GF04090GA4S01	F	-	9/14/2004	-	-	x	-	-	-	x	-	-	x	-	-
Spring 4A	0	0	WGS	Spr 4A-7-28-05	F	-	7/28/2005	-	-	-	-	-	-	x	-	-	-	-	-
Spring 4A	0	0	WGS	GU05090GA4S02	UF	-	9/27/2005	-	-	-	-	-	x	-	-	x	-	x	x
Spring 4A	0	0	WGS	GF05090GA4S01	F	-	9/27/2005	-	-	x	-	-	-	-	x	-	x	-	-

Table C-2.0-3 (continued)

Location ID	Top Depth (ft)	Bottom Depth (ft)	Media Description	Sample ID	Field Prep	Field QC Type	Collection Date	DIOX/FUR	DRO	GENINORG	GRO	Herb	HEXP	Isotope	Metals	Pest/PCB	RAD	SVOA	VOA
Spring 4A	0	0	WGS	GU05090GA4S01	UF	-	9/27/2005	-	-	x	-	-	-	-	x	-	x	-	-
Spring 4A	0	0	WGS	Spr 4A-9-27-05	F	-	9/27/2005	-	-	-	-	-	-	x	-	-	-	-	-
Spring 4A	0	0	WGS	GU060900GA4S02	UF	-	9/18/2006	x	-	x	-	-	x	-	-	x	-	x	x
Spring 4A	0	0	WGS	GU060900GA4S91	UF	Field Duplicate	9/18/2006	x	-	x	-	-	x	-	-	x	-	x	x
Spring 4A	0	0	WGS	SU060900GA4S01	UF	-	9/18/2006	-	-	-	-	-	x	-	-	-	-	-	-
Spring 4A	0	0	WGS	SU060900GA4S90	UF	Field Duplicate	9/18/2006	-	-	-	-	-	x	-	-	-	-	-	-
Spring 4A	0	0	WGS	UU060900GA4S01	UF	-	9/18/2006	-	-	-	-	-	-	-	-	-	x	-	-
Spring 4A	0	0	WGS	UU060900GA4S90	UF	Field Duplicate	9/18/2006	-	-	-	-	-	-	-	-	-	x	-	-
Spring 4A	0	0	WGS	GU060900GA4S01	UF	-	9/18/2006	-	-	x	-	-	-	-	x	-	x	-	-
Spring 4A	0	0	WGS	GU060900GA4S90	UF	Field Duplicate	9/18/2006	-	-	x	-	-	-	-	x	-	x	-	-
Spring 4A	0	0	WGS	GF060900GA4S01	F	-	9/18/2006	-	-	x	-	-	-	-	x	-	x	-	-
Spring 4A	0	0	WGS	GF060900GA4S90	F	Field Duplicate	9/18/2006	-	-	x	-	-	-	-	x	-	x	-	-
Spring 4A	0	0	WGS	GU060900GA4S01	F	-	9/18/2006	-	-	x	-	-	-	-	-	-	-	-	-

Table C-2.0-3 (continued)

Location ID	Top Depth (ft)	Bottom Depth (ft)	Media Description	Sample ID	Field Prep	Field QC Type	Collection Date	DIOX/FUR	DRO	GENINORG	GRO	Herb	HEXP	Isotope	Metals	Pest/PCB	RAD	SVOA	VOA
Spring 4A	0	0	WGS	GU060900GA4S90	F	Field Duplicate	9/18/2006	-	-	x	-	-	-	-	-	-	-	-	-
Spring 4A	0	0	WGS	GU070400GA4S01	UF	-	5/2/2007	-	-	x	-	-	x	-	x	-	-	x	x
Spring 4A	0	0	WGS	UU070400GA4S01	UF	-	5/2/2007	-	-	-	-	-	-	-	-	-	x	-	-
Spring 4A	0	0	WGS	GF070400GA4S01	F	-	5/2/2007	-	-	x	-	-	-	x	-	-	-	-	-
Spring 4A	0	0	WGS	SU070400GA4S01	UF	-	5/2/2007	-	-	-	-	-	x	-	-	-	-	-	-
Spring 4A	0	0	WGS	GU070900GA4S02	UF	-	9/24/2007	-	-	-	-	-	x	-	-	x	-	x	x
Spring 4A	0	0	WGS	UU070900GA4S01	UF	-	9/24/2007	-	-	-	-	-	-	-	-	-	x	-	-
Spring 4A	0	0	WGS	GU070900GA4S01	UF	-	9/24/2007	-	-	x	-	-	-	x	-	x	-	-	-
Spring 4A	0	0	WGS	GF070900GA4S01	F	-	9/24/2007	-	-	x	-	-	-	x	-	x	-	-	-
Spring 4A	0	0	WGS	SU070900GA4S01	UF	-	9/24/2007	-	-	-	-	-	x	-	-	-	-	-	-
Spring 4A	0	0	WGS	AU070900GA4S01	UF	-	9/24/2007	x	-	-	-	-	-	-	-	-	-	-	-
Spring 4A	0	0	WGS	CAWR-08-12111	UF	-	4/24/2008	-	-	x	-	-	x	-	x	-	-	x	x
Spring 4A	0	0	WGS	CAWR-08-12113	F	-	4/24/2008	-	-	x	-	-	-	x	-	-	-	-	-
Spring 4AA	0	0	WGS	WG9503248771	F	-	3/24/1995	-	-	x	-	-	-	-	-	-	-	-	-
Spring 4AA	0	0	WGS	AU01101GAA4	UF	-	11/1/2001	-	-	x	-	-	-	-	-	-	-	-	-
Spring 4AA	0	0	WGS	GU01101GAA4	UF	-	11/1/2001	-	-	x	-	-	-	-	-	-	-	-	-

Table C-2.0-3 (continued)

Location ID	Top Depth (ft)	Bottom Depth (ft)	Media Description	Sample ID	Field Prep	Field QC Type	Collection Date	DIOX/FUR	DRO	GENINORG	GRO	Herb	HEXP	Isotope	Metals	Pest/PCB	RAD	SVOA	VOA
Spring 4AA	0	0	WGS	MU02011GAA4	UF	-	1/28/2002	-	-	-	-	-	-	-	-	-	x	-	-
Spring 4AA	0	0	WGS	BU02011GAA4	UF	-	1/28/2002	-	-	x	-	-	-	-	-	-	-	-	-
Spring 4AA	0	0	WGS	GU02011GAA4	UF	-	1/28/2002	-	-	x	-	-	-	-	-	-	-	-	-
Spring 4AA	0	0	WGS	GU04030GAA401	UF	-	3/5/2004	-	-	x	-	-	-	-	-	-	-	-	-
Spring 4AA	0	0	WGS	GU04090GAA401	F	-	9/14/2004	-	-	x	-	-	-	-	-	-	-	-	-
Spring 4AA	0	0	WGS	GU04090GAA401	UF	-	9/14/2004	-	-	x	-	-	-	-	-	-	-	-	-
Spring 4AA	0	0	WGS	Spr 4AA-7-26-05	F	-	7/26/2005	-	-	-	-	-	-	x	-	-	-	-	-
Spring 4AA	0	0	WGS	GU05090GAA401	UF	-	9/27/2005	-	-	x	-	-	-	-	-	-	-	-	-
Spring 4AA	0	0	WGS	GF05090GAA401	F	-	9/27/2005	-	-	x	-	-	-	-	-	-	-	-	-
Spring 4AA	0	0	WGS	Spr 4AA-9-27-05	F	-	9/27/2005	-	-	-	-	-	-	x	-	-	-	-	-
Spring 4AA	0	0	WGS	GU060900GAA402	UF	-	9/18/2006	x	-	x	-	-	x	-	-	x	-	x	x
Spring 4AA	0	0	WGS	UU060900GAA401	UF	-	9/18/2006	-	-	-	-	-	-	-	-	-	x	-	-
Spring 4AA	0	0	WGS	GU060900GAA401	UF	-	9/18/2006	-	-	x	-	-	-	x	-	x	-	-	-
Spring 4AA	0	0	WGS	GF060900GAA401	F	-	9/18/2006	-	-	x	-	-	-	x	-	x	-	-	-
Spring 4AA	0	0	WGS	SU060900GAA401	UF	-	9/18/2006	-	-	-	-	-	x	-	-	-	-	-	-
Spring 4AA	0	0	WGS	GU060900GAA401	F	-	9/18/2006	-	-	x	-	-	-	-	-	-	-	-	-

Table C-2.0-3 (continued)

Location ID	Top Depth (ft)	Bottom Depth (ft)	Media Description	Sample ID	Field Prep	Field QC Type	Collection Date	DIOX/FUR	DRO	GENINORG	GRO	Herb	HEXP	Isotope	Metals	Pest/PCB	RAD	SVOA	VOA
Spring 4AA	0	0	WGS	GU070400GAA401	UF	-	5/2/2007	-	-	x	-	-	x	-	x	-	-	x	x
Spring 4AA	0	0	WGS	UU070400GAA401	UF	-	5/2/2007	-	-	-	-	-	-	-	-	-	x	-	-
Spring 4AA	0	0	WGS	GF070400GAA401	F	-	5/2/2007	-	-	x	-	-	-	-	x	-	-	-	-
Spring 4AA	0	0	WGS	SU070400GAA401	UF	-	5/2/2007	-	-	-	-	-	x	-	-	-	-	-	-
Spring 4AA	0	0	WGS	GU070900GAA402	UF	-	9/24/2007	-	-	-	-	-	x	-	-	x	-	x	x
Spring 4AA	0	0	WGS	UU070900GAA401	UF	-	9/24/2007	-	-	-	-	-	-	-	-	-	x	-	-
Spring 4AA	0	0	WGS	GU070900GAA401	UF	-	9/24/2007	-	-	x	-	-	-	-	x	-	x	-	-
Spring 4AA	0	0	WGS	GF070900GAA401	F	-	9/24/2007	-	-	x	-	-	-	-	x	-	x	-	-
Spring 4AA	0	0	WGS	SU070900GAA401	UF	-	9/24/2007	-	-	-	-	-	x	-	-	-	-	-	-
Spring 4AA	0	0	WGS	AU070900GAA401	UF	-	9/24/2007	x	-	-	-	-	-	-	-	-	-	-	-
Spring 4AA	0	0	WGS	CAWR-08-12109	UF	-	4/24/2008	-	-	x	-	-	x	-	x	-	-	x	x
Spring 4AA	0	0	WGS	CAWR-08-12108	F	-	4/24/2008	-	-	x	-	-	-	-	x	-	-	-	-
Spring 4B	0	0	WGS	WG9504208781	F	-	4/20/1995	-	-	x	-	-	-	-	x	-	x	-	-
Spring 4B	0	0	WGS	WG9509118781	F	-	9/11/1995	-	-	x	-	-	-	-	-	-	-	-	-
Spring 4B	0	0	WGS	WG9604238781	F	-	4/23/1996	-	-	x	-	-	-	-	-	-	-	-	-
Spring 4B	0	0	WGS	GC01031G4SW	UF	-	3/9/2001	-	-	x	-	-	-	-	-	-	-	-	-

Table C-2.0-3 (continued)

Location ID	Top Depth (ft)	Bottom Depth (ft)	Media Description	Sample ID	Field Prep	Field QC Type	Collection Date	DIOX/FUR	DRO	GENINORG	GRO	Herb	HEXP	Isotope	Metals	Pest/PCB	RAD	SVOA	VOA
Spring 4B	0	0	WGS	AU01101GB4S	UF	-	11/1/2001	-	-	x	-	-	-	-	-	-	-	-	-
Spring 4B	0	0	WGS	GU01101GB4S	UF	-	11/1/2001	-	-	x	-	-	-	-	-	-	-	-	-
Spring 4B	0	0	WGS	MU02011GB4S	UF	-	1/28/2002	-	-	-	-	-	-	-	-	-	x	-	-
Spring 4B	0	0	WGS	BU02011GB4S	UF	-	1/28/2002	-	-	x	-	-	-	-	-	-	-	-	-
Spring 4B	0	0	WGS	GU02011GB4S	UF	-	1/28/2002	-	-	x	-	-	-	-	-	-	-	-	-
Spring 4B	0	0	WGS	GU04030GB4S01	UF	-	3/5/2004	-	-	x	-	-	-	-	-	-	-	-	-
Spring 4B	0	0	WGS	GU04090GB4S01	F	-	9/14/2004	-	-	x	-	-	-	-	-	-	-	-	-
Spring 4B	0	0	WGS	GU04090GB4S90	F	Field Duplicate	9/14/2004	-	-	x	-	-	-	-	-	-	-	-	-
Spring 4B	0	0	WGS	GU04090GB4S01	UF	-	9/14/2004	-	-	x	-	-	-	-	-	-	-	-	-
Spring 4B	0	0	WGS	GU04090GB4S90	UF	Field Duplicate	9/14/2004	-	-	x	-	-	-	-	-	-	-	-	-
Spring 4B	0	0	WGS	Spr 4B-7-27-05	F	-	7/27/2005	-	-	-	-	-	-	x	-	-	-	-	-
Spring 4B	0	0	WGS	GU05090GB4S01	UF	-	9/26/2005	-	-	x	-	-	-	-	-	-	-	-	-
Spring 4B	0	0	WGS	GF05090GB4S01	F	-	9/26/2005	-	-	x	-	-	-	-	-	-	-	-	-
Spring 4B	0	0	WGS	GU060900GB4S02	UF	-	9/18/2006	-	-	x	-	-	x	-	-	x	-	x	x
Spring 4B	0	0	WGS	UU060900GB4S01	UF	-	9/18/2006	-	-	-	-	-	-	-	-	-	x	-	-

Table C-2.0-3 (continued)

Location ID	Top Depth (ft)	Bottom Depth (ft)	Media Description	Sample ID	Field Prep	Field QC Type	Collection Date	DIOX/FUR	DRO	GENINORG	GRO	Herb	HEXP	Isotope	Metals	Pest/PCB	RAD	SVOA	VOA
Spring 4B	0	0	WGS	GU060900GB4S01	UF	-	9/18/2006	-	-	x	-	-	-	-	x	-	x	-	-
Spring 4B	0	0	WGS	GF060900GB4S01	F	-	9/18/2006	-	-	x	-	-	-	-	x	-	x	-	-
Spring 4B	0	0	WGS	SU060900GB4S01	UF	-	9/18/2006	-	-	-	-	-	x	-	-	-	-	-	-
Spring 4B	0	0	WGS	GU060900GB4S01	F	-	9/18/2006	-	-	x	-	-	-	-	-	-	-	-	-
Spring 4B	0	0	WGS	GU070400GB4S01	UF	-	5/1/2007	-	-	x	-	-	x	-	x	-	-	x	x
Spring 4B	0	0	WGS	UU070400GB4S01	UF	-	5/1/2007	-	-	-	-	-	-	-	-	-	x	-	-
Spring 4B	0	0	WGS	GF070400GB4S01	F	-	5/1/2007	-	-	x	-	-	-	-	x	-	-	-	-
Spring 4B	0	0	WGS	SU070400GB4S01	UF	-	5/1/2007	-	-	-	-	-	x	-	-	-	-	-	-
Spring 4B	0	0	WGS	GU070900GB4S02	UF	-	9/25/2007	-	-	-	-	-	x	-	-	x	-	x	x
Spring 4B	0	0	WGS	UU070900GB4S01	UF	-	9/25/2007	-	-	-	-	-	-	-	-	-	x	-	-
Spring 4B	0	0	WGS	GF070900GB4S01	F	-	9/25/2007	-	-	x	-	-	-	-	x	-	x	-	-
Spring 4B	0	0	WGS	GU070900GB4S01	UF	-	9/25/2007	-	-	x	-	-	-	-	x	-	x	-	-
Spring 4B	0	0	WGS	SU070900GB4S01	UF	-	9/25/2007	-	-	-	-	-	x	-	-	-	-	-	-
Spring 4B	0	0	WGS	CAWR-08-12102	UF	-	4/24/2008	-	-	x	-	-	x	-	x	-	x	x	x
Spring 4B	0	0	WGS	CAWR-08-12104	F	-	4/24/2008	-	-	x	-	-	-	-	x	-	-	-	-
Spring 4C	0	0	WGS	WG9509118791	F	-	9/11/1995	-	-	x	-	-	-	-	-	-	-	-	-

Table C-2.0-3 (continued)

Location ID	Top Depth (ft)	Bottom Depth (ft)	Media Description	Sample ID	Field Prep	Field QC Type	Collection Date	DIOX/FUR	DRO	GENINORG	GRO	Herb	HEXP	Isotope	Metals	Pest/PCB	RAD	SVOA	VOA
Spring 4C	0	0	WGS	WG9604238791	F	-	4/23/1996	-	-	x	-	-	-	-	-	-	-	-	-
Spring 4C	0	0	WGS	WG9610078791	F	-	10/7/1996	-	-	x	-	-	-	-	-	-	-	-	-
Spring 4C	0	0	WGS	AU01101GC4S	UF	-	11/1/2001	-	-	x	-	-	-	-	-	-	-	-	-
Spring 4C	0	0	WGS	GU01101GC4S	UF	-	11/1/2001	-	-	x	-	-	-	-	-	-	-	-	-
Spring 4C	0	0	WGS	MU02011GC4S	UF	-	1/28/2002	-	-	-	-	-	-	-	-	-	x	-	-
Spring 4C	0	0	WGS	BU02011GC4S	UF	-	1/28/2002	-	-	x	-	-	-	-	-	-	-	-	-
Spring 4C	0	0	WGS	GU02011GC4S	UF	-	1/28/2002	-	-	x	-	-	-	-	-	-	-	-	-
Spring 4C	0	0	WGS	GU04030GC4S01	UF	-	3/5/2004	-	-	x	-	-	-	-	-	-	-	-	-
Spring 4C	0	0	WGS	GU04090GC4S01	F	-	9/14/2004	-	-	x	-	-	-	-	-	-	-	-	-
Spring 4C	0	0	WGS	GU04090GC4S01	UF	-	9/14/2004	-	-	x	-	-	-	-	-	-	-	-	-
Spring 4C	0	0	WGS	Spr 4C-7-27-05	F	-	7/27/2005	-	-	-	-	-	x	-	-	-	-	-	-
Spring 4C	0	0	WGS	GU05090GC4S01	UF	-	9/27/2005	-	-	x	-	-	-	-	-	-	-	-	-
Spring 4C	0	0	WGS	GU05090GC4S90	UF	Field Duplicate	9/27/2005	-	-	x	-	-	-	-	-	-	-	-	-
Spring 4C	0	0	WGS	GF05090GC4S01	F	-	9/27/2005	-	-	x	-	-	-	-	-	-	-	-	-
Spring 4C	0	0	WGS	GF05090GC4S90	F	Field Duplicate	9/27/2005	-	-	x	-	-	-	-	-	-	-	-	-

Table C-2.0-3 (continued)

Location ID	Top Depth (ft)	Bottom Depth (ft)	Media Description	Sample ID	Field Prep	Field QC Type	Collection Date	DIOX/FUR	DRO	GENINORG	GRO	Herb	HEXP	Isotope	Metals	Pest/PCB	RAD	SVOA	VOA
Spring 4C	0	0	WGS	GU060900GC4S02	UF	-	9/19/2006	-	-	x	-	-	x	-	-	x	-	x	x
Spring 4C	0	0	WGS	UU060900GC4S01	UF	-	9/19/2006	-	-	-	-	-	-	-	-	-	x	-	-
Spring 4C	0	0	WGS	GU060900GC4S01	UF	-	9/19/2006	-	-	x	-	-	-	-	x	-	x	-	-
Spring 4C	0	0	WGS	GF060900GC4S01	F	-	9/19/2006	-	-	x	-	-	-	-	x	-	x	-	-
Spring 4C	0	0	WGS	SU060900GC4S01	UF	-	9/19/2006	-	-	-	-	-	x	-	-	-	-	-	-
Spring 4C	0	0	WGS	GU060900GC4S01	F	-	9/19/2006	-	-	x	-	-	-	-	-	-	-	-	-
Spring 4C	0	0	WGS	GU070400GC4S01	UF	-	5/1/2007	-	-	x	-	-	x	-	x	-	-	x	x
Spring 4C	0	0	WGS	UU070400GC4S01	UF	-	5/1/2007	-	-	-	-	-	-	-	-	-	x	-	-
Spring 4C	0	0	WGS	GF070400GC4S01	F	-	5/1/2007	-	-	x	-	-	-	-	x	-	-	-	-
Spring 4C	0	0	WGS	SU070400GC4S01	UF	-	5/1/2007	-	-	-	-	-	x	-	-	-	-	-	-
Spring 4C	0	0	WGS	GU070900GC4S02	UF	-	9/25/2007	-	-	-	-	-	x	-	-	x	-	x	x
Spring 4C	0	0	WGS	UU070900GC4S01	UF	-	9/25/2007	-	-	-	-	-	-	-	-	-	x	-	-
Spring 4C	0	0	WGS	GU070900GC4S01	UF	-	9/25/2007	-	-	x	-	-	-	-	x	-	x	-	-
Spring 4C	0	0	WGS	GF070900GC4S01	F	-	9/25/2007	-	-	x	-	-	-	-	x	-	x	-	-
Spring 4C	0	0	WGS	SU070900GC4S01	UF	-	9/25/2007	-	-	-	-	-	x	-	-	-	-	-	-
Spring 4C	0	0	WGS	CAWR-08-12106	UF	-	4/24/2008	-	-	x	-	-	x	-	x	-	x	x	x

Table C-2.0-3 (continued)

Location ID	Top Depth (ft)	Bottom Depth (ft)	Media Description	Sample ID	Field Prep	Field QC Type	Collection Date	DIOX/FUR	DRO	GENINORG	GRO	Herb	HEXP	Isotope	Metals	Pest/PCB	RAD	SVOA	VOA
Spring 4C	0	0	WGS	CAWR-08-12105	F	-	4/24/2008	-	-	x	-	-	-	-	x	-	-	-	-
Starmer Spring	0	0	WGS	GU04070GSTS01	UF	-	9/10/2004	-	-	x	-	-	x	-	x	x	x	x	x
Starmer Spring	0	0	WGS	GU04070GSTS90	UF	Field Duplicate	9/10/2004	-	-	x	-	-	x	-	x	x	x	x	x
Starmer Spring	0	0	WGS	GF04070GSTS01	F	-	9/10/2004	-	-	x	-	-	-	-	x	-	x	-	-
Starmer Spring	0	0	WGS	GF04070GSTS90	F	Field Duplicate	9/10/2004	-	-	x	-	-	-	-	x	-	x	-	-
Starmer Spring	0	0	WGS	GU05060GSTS01	UF	-	6/21/2005	-	-	x	-	-	x	-	x	x	x	x	-
Starmer Spring	0	0	WGS	GF05060GSTS01	F	-	6/21/2005	-	-	x	-	-	-	-	x	-	x	-	-
Starmer Spring	0	0	WGS	GU060800GSTS01	UF	-	8/23/2006	-	-	x	-	x	x	-	x	x	x	x	x
Starmer Spring	0	0	WGS	UU060800GSTS01	UF	-	8/23/2006	-	-	-	-	-	-	-	-	-	x	-	-
Starmer Spring	0	0	WGS	GF060800GSTS01	F	-	8/23/2006	-	-	x	-	-	-	-	x	-	x	-	-
Starmer Spring	0	0	WGS	SU060800GSTS01	UF	-	8/23/2006	-	-	-	-	-	x	-	-	-	-	-	-
Starmer Spring	0	0	WGS	GU060800GSTS01	F	-	8/23/2006	-	-	x	-	-	-	-	-	-	-	-	-
Starmer Spring	0	0	WGS	GU061200GSTS01	UF	-	12/6/2006	-	-	x	-	-	x	-	x	x	x	x	x
Starmer Spring	0	0	WGS	UU061200GSTS01	UF	-	12/6/2006	-	-	-	-	-	-	-	-	-	x	-	-
Starmer Spring	0	0	WGS	GF061200GSTS01	F	-	12/6/2006	-	-	x	-	-	-	-	x	-	x	-	-

Table C-2.0-3 (continued)

Location ID	Top Depth (ft)	Bottom Depth (ft)	Media Description	Sample ID	Field Prep	Field QC Type	Collection Date	DIOX/FUR	DRO	GENINORG	GRO	Herb	HEXP	Isotope	Metals	Pest/PCB	RAD	SVOA	VOA
Starmer Spring	0	0	WGS	SU061200GSTS01	UF	-	12/6/2006	-	-	-	-	-	X	-	-	-	-	-	-
Starmer Spring	0	0	WGS	GU061200GSTS01	F	-	12/6/2006	-	-	X	-	-	-	-	-	-	-	-	-
Starmer Spring	0	0	WGS	GU070300GSTS01	UF	-	3/21/2007	-	-	X	-	-	X	-	X	X	X	X	X
Starmer Spring	0	0	WGS	UU070300GSTS01	UF	-	3/21/2007	-	-	-	-	-	-	-	-	-	X	-	-
Starmer Spring	0	0	WGS	GF070300GSTS01	F	-	3/21/2007	-	-	X	-	-	-	-	X	-	X	-	-
Starmer Spring	0	0	WGS	SU070300GSTS01	UF	-	3/21/2007	-	-	-	-	-	X	-	-	-	-	-	-
Starmer Spring	0	0	WGS	GU070600GSTS01	UF	-	7/10/2007	-	-	X	-	-	X	-	X	X	X	X	X
Starmer Spring	0	0	WGS	UU070600GSTS01	UF	-	7/10/2007	-	-	-	-	-	-	-	-	-	X	-	-
Starmer Spring	0	0	WGS	GF070600GSTS01	F	-	7/10/2007	-	-	X	-	-	-	-	X	-	X	-	-
Starmer Spring	0	0	WGS	SU070600GSTS01	UF	-	7/10/2007	-	-	-	-	-	X	-	-	-	-	-	-
Starmer Spring	0	0	WGS	GU070800GSTS01	UF	-	9/20/2007	-	-	X	-	X	X	-	X	X	X	X	X
Starmer Spring	0	0	WGS	UU070800GSTS01	UF	-	9/20/2007	-	-	-	-	-	-	-	-	-	X	-	-
Starmer Spring	0	0	WGS	GF070800GSTS01	F	-	9/20/2007	-	-	X	-	-	-	-	X	-	X	-	-
Starmer Spring	0	0	WGS	SU070800GSTS01	UF	-	9/20/2007	-	-	-	-	-	X	-	-	-	-	-	-
Starmer Spring	0	0	WGS	CAPA-08-9219	UF	-	12/3/2007	-	-	X	-	-	X	-	X	X	X	X	X
Starmer Spring	0	0	WGS	CAPA-08-9218	F	-	12/3/2007	-	-	X	-	-	-	-	X	-	X	-	-

Table C-2.0-3 (continued)

Location ID	Top Depth (ft)	Bottom Depth (ft)	Media Description	Sample ID	Field Prep	Field QC Type	Collection Date	DIOX/FUR	DRO	GENINORG	GRO	Herb	HEXP	Isotope	Metals	Pest/PCB	RAD	SVOA	VOA
Starmer Spring	0	0	WGS	CAPA-08-10966	UF	-	3/11/2008	-	-	x	-	-	x	-	x	x	x	x	x
Starmer Spring	0	0	WGA	CAPA-08-13057	UF	-	6/24/2008	-	-	x	-	-	x	-	x	x	x	x	x
Starmer Spring	0	0	WGA	CAPA-08-13056	F	-	6/24/2008	-	-	x	-	-	-	-	x	-	x	-	-
Starmer Spring	n/p	n/p	WGS	CAPA-08-10965	F	-	3/11/2008	-	-	x	-	-	-	-	x	-	x	-	-
TA-18 Spring	0	0	WGS	GU04070GS1801	UF	-	9/14/2004	-	-	x	-	-	x	-	x	x	x	x	x
TA-18 Spring	0	0	WGS	GF04070GS1801	F	-	9/14/2004	-	-	x	-	-	-	-	x	-	x	-	-
TA-18 Spring	0	0	WGS	GU05060GS1801	UF	-	6/22/2005	-	-	x	-	-	x	-	x	x	x	x	-
TA-18 Spring	0	0	WGS	GF05060GS1801	F	-	6/22/2005	-	-	x	-	-	-	-	x	-	x	-	-
TA-18 Spring	0	0	WGS	GU070300GS1801	UF	-	3/20/2007	-	-	x	-	-	x	-	x	x	x	x	x
TA-18 Spring	0	0	WGS	GU070300GS1820	UF	Field Duplicate	3/20/2007	-	-	x	-	-	x	-	x	x	x	x	x
TA-18 Spring	0	0	WGS	UU070300GS1801	UF	-	3/20/2007	-	-	-	-	-	-	-	-	-	x	-	-
TA-18 Spring	0	0	WGS	UU070300GS1820	UF	Field Duplicate	3/20/2007	-	-	-	-	-	-	-	-	-	x	-	-
TA-18 Spring	0	0	WGS	GF070300GS1801	F	-	3/20/2007	-	-	x	-	-	-	-	x	-	x	-	-
TA-18 Spring	0	0	WGS	GF070300GS1820	F	Field Duplicate	3/20/2007	-	-	x	-	-	-	-	x	-	x	-	-
TA-18 Spring	0	0	WGS	SU070300GS1801	UF	-	3/20/2007	-	-	-	-	-	x	-	-	-	-	-	-

Table C-2.0-3 (continued)

Location ID	Top Depth (ft)	Bottom Depth (ft)	Media Description	Sample ID	Field Prep	Field QC Type	Collection Date	DIOX/FUR	DRO	GENINORG	GRO	Herb	HEXP	Isotope	Metals	Pest/PCB	RAD	SVOA	VOA
TA-18 Spring	0	0	WGS	SU070300GS1820	UF	Field Duplicate	3/20/2007	-	-	-	-	-	x	-	-	-	-	-	-
TA-18 Spring	0	0	WGS	GU070600GS1801	UF	-	6/26/2007	-	-	x	-	-	x	-	x	x	x	x	x
TA-18 Spring	0	0	WGS	GU070600GS1820	UF	Field Duplicate	6/26/2007	-	-	x	-	-	x	-	x	x	x	x	x
TA-18 Spring	0	0	WGS	UU070600GS1801	UF	-	6/26/2007	-	-	-	-	-	-	-	-	-	x	-	-
TA-18 Spring	0	0	WGS	UU070600GS1820	UF	Field Duplicate	6/26/2007	-	-	-	-	-	-	-	-	-	x	-	-
TA-18 Spring	0	0	WGS	GF070600GS1801	F	-	6/26/2007	-	-	x	-	-	-	-	x	-	x	-	-
TA-18 Spring	0	0	WGS	GF070600GS1820	F	Field Duplicate	6/26/2007	-	-	x	-	-	-	-	x	-	x	-	-
TA-18 Spring	0	0	WGS	SU070600GS1801	UF	-	6/26/2007	-	-	-	-	-	x	-	-	-	-	-	-
TA-18 Spring	0	0	WGS	SU070600GS1820	UF	Field Duplicate	6/26/2007	-	-	-	-	-	x	-	-	-	-	-	-
TA-18 Spring	0	0	WGS	GU070800GS1801	UF	-	9/17/2007	-	-	x	-	x	x	-	x	x	x	x	x
TA-18 Spring	0	0	WGS	UU070800GS1801	UF	-	9/17/2007	-	-	-	-	-	-	-	-	-	x	-	-
TA-18 Spring	0	0	WGS	GF070800GS1801	F	-	9/17/2007	-	-	x	-	-	-	-	x	-	x	-	-
TA-18 Spring	0	0	WGS	SU070800GS1801	UF	-	9/17/2007	-	-	-	-	-	x	-	-	-	-	-	-

Table C-2.0-3 (continued)

Location ID	Top Depth (ft)	Bottom Depth (ft)	Media Description	Sample ID	Field Prep	Field QC Type	Collection Date	DIOX/FUR	DRO	GENINORG	GRO	Herb	HEXP	Isotope	Metals	Pest/PCB	RAD	SVOA	VOA
TA-18 Spring	0	0	WGS	CAPA-08-9277	UF	-	12/12/2007	-	-	x	-	-	x	-	x	x	x	x	x
TA-18 Spring	0	0	WGS	CAPA-08-9278	F	-	12/12/2007	-	-	x	-	-	-	-	x	-	x	-	-
TA-18 Spring	0	0	WGA	CAPA-08-13073	UF	-	6/23/2008	-	-	x	-	-	x	-	x	x	x	x	x
TA-18 Spring	0	0	WGA	CAPA-08-13074	F	-	6/23/2008	-	-	x	-	-	-	-	x	-	x	-	-
Threemile Spring	0	0	WGS	MNM95080042	UF	-	8/18/1995	-	-	x	-	-	-	-	x	-	-	-	-
Threemile Spring	0	0	WGS	MNM95080042	F	-	8/18/1995	-	-	x	-	-	-	-	-	-	-	-	-
Threemile Spring	0	0	WGS	GU05060GSM301	UF	-	6/30/2005	-	-	x	-	-	x	-	x	x	x	x	x
Threemile Spring	0	0	WGS	GF05060GSM301	F	-	6/30/2005	-	-	x	-	-	-	-	x	-	x	-	-
Threemile Spring	0	0	WGS	GU070300GSM301	UF	-	3/20/2007	-	-	x	-	-	x	-	x	x	x	x	x
Threemile Spring	0	0	WGS	UU070300GSM301	UF	-	3/20/2007	-	-	-	-	-	-	-	-	-	x	-	-
Threemile Spring	0	0	WGS	GF070300GSM301	F	-	3/20/2007	-	-	x	-	-	-	-	x	-	x	-	-
Threemile Spring	0	0	WGS	SU070300GSM301	UF	-	3/20/2007	-	-	-	-	-	x	-	-	-	-	-	-

Table C-2.0-3 (continued)

Location ID	Top Depth (ft)	Bottom Depth (ft)	Media Description	Sample ID	Field Prep	Field QC Type	Collection Date	DIOX/FUR	DRO	GENINORG	GRO	Herb	HEXP	Isotope	Metals	Pest/PCB	RAD	SVOA	VOA
TW-1.72 Spring	0	0	WGS	GU05060G17201	UF	-	6/28/2005	-	-	x	-	-	x	-	x	x	x	x	x
TW-1.72 Spring	0	0	WGS	GF05060G17201	F	-	6/28/2005	-	-	x	-	-	-	-	x	-	x	-	-
TW-1.72 Spring	0	0	WGS	GU061100G17201	UF	-	12/13/2006	-	-	x	-	-	x	-	x	x	x	x	x
TW-1.72 Spring	0	0	WGS	GF061100G17201	F	-	12/13/2006	-	-	x	-	-	-	-	x	-	x	-	-
TW-1.72 Spring	0	0	WGS	GU061100G17201	F	-	12/13/2006	-	-	x	-	-	-	-	-	-	-	-	-

^a - = Analysis was not performed.
^b x= Analysis was performed.
^c n/p = Not provided.

**Table C-2.0-4
Pajarito Canyon Watershed Core Samples Collected**

Location ID	Top Depth (ft)	Bottom Depth (ft)	Sample ID	Media Description	Field QC Type Code	Collection Date	GENINORG	HEXP	Iso U	Metals	PCB	Perchlorate	RAD	VOC
3MAO-1a	1.5	2	CAPA-08-11416	Alluvial Core	-	3/28/2008	- ^a	x ^b	x	x	x	x	-	x
3MAO-2	10	10	CAPA-08-11411	Alluvial Core	-	6/2/2008	-	x	x	x	x	x	-	-
3MAO-2	20	20	CAPA-08-11412	Alluvial Core	-	6/2/2008	-	x	x	x	x	x	-	-
3MAO-2	30	30	CAPA-08-11414	Alluvial Core	Field Duplicate	6/3/2008	-	x	x	x	x	x	-	-
3MAO-2	30	30	CAPA-08-11415	Alluvial Core	-	6/3/2008	-	x	x	x	x	x	-	-
PCAO-2	3	3	CAPA-08-10302	Alluvial Core	-	3/20/2008	-	x	x	x	x	x	-	-
PCAO-3	1.5	2	CAPA-08-10304	Alluvial Core	-	3/21/2008	-	x	x	x	x	x	-	-
PCAO-4	1	1.5	CAPA-08-10306	Alluvial Core	-	3/25/2008	-	x	x	x	x	x	-	-
PCAO-5	10	10	CAPA-08-10324	Alluvial Core	-	4/30/2008	-	x	x	x	x	x	-	-
PCAO-5	19	19	CAPA-08-10325	Alluvial Core	-	4/30/2008	-	x	x	x	x	x	-	-
PCAO-5	24.7	24.7	CAPA-08-10326	Alluvial Core	-	4/30/2008	-	x	x	x	x	x	-	-
PCAO-5	30	30	CAPA-08-10364	Alluvial Core	-	4/30/2008	-	x	x	x	x	x	-	-
PCAO-6	25	25	CAPA-08-13235	Alluvial Core	-	6/4/2008	-	x	x	x	x	x	-	-
PCAO-6	25	25	CAPA-08-13236	Alluvial Core	Field Duplicate	6/4/2008	-	x	x	x	x	x	-	-
PCAO-7a	10	10	CAPA-08-10327	Alluvial Core	-	5/28/2008	-	x	x	x	x	x	-	-
PCAO-7a	20	20	CAPA-08-10328	Alluvial Core	-	5/28/2008	-	x	x	x	x	x	-	-
PCAO-7a	30	30	CAPA-08-10329	Alluvial Core	-	5/29/2008	-	x	x	x	x	x	-	-
PCAO-7a	35	35	CAPA-08-10330	Alluvial Core	-	5/29/2008	-	x	x	x	x	x	-	-
PCAO-7a	35	35	CAPA-08-10332	Alluvial Core	Field Duplicate	5/29/2008	-	x	x	x	x	x	-	-

Table C-2.0-4 (continued)

Location ID	Top Depth (ft)	Bottom Depth (ft)	Sample ID	Media Description	Field QC Type Code	Collection Date	GENINORG	HEXP	Iso U	Metals	PCB	Perchlorate	RAD	VOC
PCAO-7b2	10	10	CAPA-08-10337	Alluvial Core	-	5/18/2008	-	x	x	x	x	x	-	-
PCAO-7b2	10	10	CAPA-08-10344	Alluvial Core	Field Duplicate	5/18/2008	-	x	x	x	x	x	-	-
PCAO-7b2	20	20	CAPA-08-10338	Alluvial Core	-	5/18/2008	-	x	x	x	x	x	-	-
PCAO-7b2	30	30	CAPA-08-10339	Alluvial Core	-	5/18/2008	-	x	x	x	x	x	-	-
PCAO-7b2	40	40	CAPA-08-10340	Alluvial Core	-	5/18/2008	-	x	x	x	x	x	-	-
PCAO-7b2	50	50	CAPA-08-10342	Alluvial Core	-	5/18/2008	-	x	x	x	x	x	-	-
PCAO-7b2	60	60	CAPA-08-10343	Alluvial Core	-	5/18/2008	-	x	x	x	x	x	-	-
PCAO-7b2	64.5	64.5	CAPA-08-10345	Alluvial Core	-	5/19/2008	-	x	x	x	x	x	-	-
PCAO-7c	10	10	CAPA-08-11422	Alluvial Core	-	5/7/2008	-	x	x	x	x	x	-	-
PCAO-7c	20	20	CAPA-08-11423	Alluvial Core	-	5/8/2008	-	x	x	x	x	x	-	-
PCAO-7c	30	30	CAPA-08-11424	Alluvial Core	-	5/8/2008	-	x	x	x	x	x	-	-
PCAO-7c	40	40	CAPA-08-11425	Alluvial Core	-	5/8/2008	-	x	x	x	x	x	-	-
PCAO-7c	50	50	CAPA-08-11427	Alluvial Core	-	5/8/2008	-	x	x	x	x	x	-	-
PCAO-7c	60	60	CAPA-08-11428	Alluvial Core	-	5/13/2008	-	x	x	x	x	x	-	-
PCAO-8	10	10	CAPA-08-10362	Alluvial Core	-	5/31/2008	-	x	x	x	x	x	-	-
PCAO-8	20	20	CAPA-08-10356	Alluvial Core	-	5/31/2008	-	x	x	x	x	x	-	-
PCAO-8	30	30	CAPA-08-10351	Alluvial Core	-	5/31/2008	-	x	x	x	x	x	-	-
PCAO-8	40	40	CAPA-08-10352	Alluvial Core	-	6/1/2008	-	x	x	x	x	x	-	-
PCAO-8	41	45	CAPA-08-10354	Alluvial Core	-	6/1/2008	-	x	x	x	x	x	-	-
PCAO-8	41	45	CAPA-08-10357	Alluvial Core	Field Duplicate	6/1/2008	-	x	x	x	x	x	-	-

Table C-2.0-4 (continued)

Location ID	Top Depth (ft)	Bottom Depth (ft)	Sample ID	Media Description	Field QC Type Code	Collection Date	GENINORG	HEXP	Iso U	Metals	PCB	Perchlorate	RAD	VOC
PCAO-9	10	10	CAPA-08-13336	Alluvial Core	-	6/10/2008	-	x	x	x	x	x	-	-
PCAO-9	25	25	CAPA-08-13337	Alluvial Core	-	6/11/2008	-	x	x	x	x	x	-	-
TMO-1	4.5	5	CAPA-08-10358	Alluvial Core	-	3/24/2008	-	x	x	x	x	x	-	-
R-17	23.1	25.5	GW17-06-64539	Regional Well Core	-	11/3/2005	x	-	-	x	-	-	x	-
R-17	30	32.5	GW17-06-64540	Regional Well Core	-	11/3/2005	x	-	-	x	-	-	x	-
R-17	39.3	41.6	GW17-06-64541	Regional Well Core	-	11/3/2005	x	-	-	x	-	-	x	-
R-17	53	55.3	GW17-06-64542	Regional Well Core	-	11/4/2005	x	-	-	x	-	-	x	-
R-17	83	85.2	GW17-06-64544	Regional Well Core	-	11/4/2005	x	-	-	x	-	-	x	-
R-17	93	95.2	GW17-06-64545	Regional Well Core	-	11/4/2005	x	-	-	x	-	-	x	-
R-17	100	102.2	GW17-06-64546	Regional Well Core	-	11/4/2005	x	-	-	x	-	-	x	-
R-17	247.9	250.1	GW17-06-64549	Regional Well Core	-	11/17/2005	x	-	-	x	-	-	x	-
R-17	297.9	300	GW17-06-64550	Regional Well Core	-	11/18/2005	x	-	-	x	-	-	x	-
20-02-20857 (R-20)	6.5	7	GW20-02-47680	Regional Well Core	-	8/4/2002	x	-	-	x	-	-	-	-
20-02-20857 (R-20)	7.5	10	GW20-02-47681	Regional Well Core	-	8/4/2002	-	-	-	-	-	-	x	-
20-02-20857 (R-20)	17.7	19.5	GW20-02-47682	Regional Well Core	-	8/14/2002	x	-	-	x	-	-	x	-
20-02-20857 (R-20)	27.8	29.6	GW20-02-47683	Regional Well Core	-	8/4/2002	x	-	-	x	-	-	x	-
20-02-20857 (R-20)	47.5	48.7	GW20-02-47685	Regional Well Core	-	8/5/2002	x	-	-	x	-	-	x	-
20-02-20857 (R-20)	84.5	86	GW20-02-47664	Regional Well Core	-	10/16/2002	x	-	-	x	-	-	x	-
20-02-20857 (R-20)	113.8	116	GW20-02-47666	Regional Well Core	-	10/16/2002	x	-	-	x	-	-	x	-
20-02-20857 (R-20)	146.3	149.5	GW20-02-47667	Regional Well Core	-	10/16/2002	x	-	-	x	-	-	x	-

Table C-2.0-4 (continued)

Location ID	Top Depth (ft)	Bottom Depth (ft)	Sample ID	Media Description	Field OC Type Code	Collection Date	GENINORG	HEXP	Iso U	Metals	PCB	Perchlorate	RAD	VOC
20-02-20857 (R-20)	196.3	198.3	GW20-02-47668	Regional Well Core	-	10/17/2002	-	-	-	-	-	-	x	-
20-02-20857 (R-20)	202.7	203.9	GW20-02-47669	Regional Well Core	-	10/17/2002	x	-	-	x	-	-	x	-
20-02-20857 (R-20)	341.5	342	GW20-02-47672	Regional Well Core	-	10/18/2002	x	-	-	x	-	-	x	-
20-02-20857 (R-20)	402	403.5	GW20-02-47676	Regional Well Core	-	10/18/2002	x	-	-	x	-	-	x	-
32-02-20856 (R-32)	31	32.3	GW32-02-47613	Regional Well Core	-	7/13/2002	-	-	-	-	-	-	x	-
32-02-20856 (R-32)	60	62.5	GW32-02-47614	Regional Well Core	-	7/15/2002	-	-	-	-	-	-	x	-
32-02-20856 (R-32)	63	66	GW32-02-47615	Regional Well Core	-	7/15/2002	x	-	-	x	-	-	x	-
32-02-20856 (R-32)	76	79.2	GW32-02-47616	Regional Well Core	-	7/15/2002	x	-	-	x	-	-	x	-
32-02-20856 (R-32)	101	104.2	GW32-02-47617	Regional Well Core	-	7/15/2002	x	-	-	x	-	-	x	-
32-02-20856 (R-32)	136	139.2	GW32-02-47619	Regional Well Core	-	7/15/2002	x	-	-	x	-	-	x	-
32-02-20856 (R-32)	206	208	GW32-02-47622	Regional Well Core	-	7/16/2002	-	-	-	-	-	-	x	-
32-02-20856 (R-32)	211	211.7	GW32-02-47623	Regional Well Core	-	7/16/2002	x	-	-	x	-	-	-	-
32-02-20856 (R-32)	277	280.2	GW32-02-47624	Regional Well Core	-	7/17/2002	x	-	-	x	-	-	x	-
32-02-20856 (R-32)	291	302	GW32-02-47626	Regional Well Core	-	7/17/2002	-	-	-	-	-	-	x	-

^a - = Analysis was not performed.

^b x = Analysis was performed.

**Table C-2.0-5
Pajarito Canyon Watershed Biota Samples Collected**

Reach	Location ID	Sample ID	Media Description	Field QC Type	Collection Date	Metals	PCB	Perchlorate
AW-1	TW-603364	CATW-08-11629	Eggs	-	3/19/2008	x ^a	- ^b	-
n/a ^c	PA-603362	CAPA-08-11627	Eggs	-	3/19/2008	x	-	-
n/a	TH-603363	CATH-08-11628	Eggs	-	3/19/2008	x	-	-
AW-1	PA-603374	CAPA-08-11884	Insects	-	4/3/2008	x	-	-
PA-2W	PA-603376	CAPA-08-11886	Insects	-	4/3/2008	x	-	-
PA-3E	PA-603377	CAPA-08-11887	Insects	-	4/3/2008	x	-	-
PAS-1E	PA-603375	CAPA-08-11885	Insects	-	4/3/2008	x	-	-
TWSE-1W	TW-603378	CATW-08-11888	Insects	-	4/3/2008	x	-	-
AEN-1	PA-24871	CAPA-08-11160	Worms	-	3/6/2008	x	x	x
AW-1	PA-26410	CAPA-08-11161	Worms	-	3/6/2008	x	x	x
PA-0	PA-26500	CAPA-08-11162	Worms	-	3/6/2008	x	x	x
PA-1E	PA-603098	CAPA-08-11163	Worms	-	3/6/2008	x	x	x
PA-4	PA-22890	CAPA-08-11164	Worms	-	3/6/2008	x	x	x
PA-4	PA-22890	CAPA-08-11165	Worms	Collocated	3/6/2008	x	-	x
PAS-1E	PA-26418	CAPA-08-12046	Worms	-	3/17/2008	x	x	x
PAS-1E	PA-26418	CAPA-08-12045	Worms	Collocated	3/17/2008	x	x	x
THM-1	TH-25024	CATH-08-11171	Worms	-	3/6/2008	x	x	x
TW-1E	TW-24830	CATW-08-11170	Worms	Collocated	3/6/2008	x	x	x
TW-1E	TW-24830	CATW-08-11166	Worms	-	3/6/2008	x	x	x
TW-1W	TW-26460	CATW-08-11167	Worms	-	3/6/2008	x	x	x
TWN-1E	TW-24836	CATW-08-11168	Worms	-	3/6/2008	x	x	x
TWSE-1W	TW-26524	CATW-08-11169	Worms	-	3/6/2008	x	x	x

^a x= Analysis was performed.

^b - = Analysis was not performed.

^c n/a = Not associated with a reach.

**Table C-2.0-6
Media Code Definitions**

Media Code	Media Description
QAL	Alluvial Core
QBTT	Alluvial Core
R	Regional Well Core
SED	Alluvial Core
SED	Sediment (SED)
WG	Alluvial Groundwater (WGA)
WG	Intermediate Groundwater (WGI)
WG	Regional Groundwater (WGR)
WG	Springs (WGS)
WM	Snowmelt (WM)
WP	Pooled water (WP)
WS	Surface water (WS)
WT	Stormwater (WT)
N/A	Eggs
N/A	Insects
N/A	Worms

**Table C-4.0-1
Reporting Qualifier Definitions**

LANL Reporting Qualifier	Definition
J	The analyte is classified as detected but the reported concentration value is expected to be more uncertain than usual.
J+	The analyte is classified as detected but the reported concentration value is expected to be more uncertain than usual with a potential positive bias.
J-	The analyte is classified as detected but the reported concentration value is expected to be more uncertain than usual with a potential negative bias.
JN+	Presumptive evidence of the presence of the material at an estimated quantity with a suspected positive bias.
JN-	Presumptive evidence of the presence of the material at an estimated quantity with a suspected negative bias.
N	Presumptive evidence of the presence of the material.
NJ	Analyte has been tentatively identified and the associated numerical value is estimated based upon 1:1 response factor to the nearest eluting internal standard
NQ	Not qualified
R	The sample results were rejected because of serious deficiencies in the ability to analyze the sample and meet quality control criteria; the presence or absence cannot be verified.
U	The analyte was analyzed for but not detected; the reported value is the sample-specific EQL (estimated quantitation limit) or detection limit.
UJ	The analyte was analyzed for but not detected; the reported value is an estimate of the sample-specific quantitation limit or detection limit.

Table C-5.0-1
Inorganic Chemical Analytical Methods

Analytical Suite	Analytical Methods
ANION	EPA:300
ANION	EPA:300.0
ANION	EPA:314.0
Cyanide	SW-846:9010
Cyanide	SW-846:9012A
GENINORG	ASTM:D5057
GENINORG	EPA:120.1
GENINORG	EPA:150.1
GENINORG	EPA:160.1
GENINORG	EPA:160.2
GENINORG	EPA:160.4
GENINORG	EPA:200.7
GENINORG	EPA:200.8
GENINORG	EPA:300.0
GENINORG	EPA:310.1
GENINORG	EPA:310.2
GENINORG	EPA:314.0
GENINORG	EPA:320.1
GENINORG	EPA:325.1
GENINORG	EPA:325.2
GENINORG	EPA:335.1
GENINORG	EPA:335.2
GENINORG	EPA:335.3
GENINORG	EPA:340.2
GENINORG	EPA:350.1
GENINORG	EPA:350.3
GENINORG	EPA:351.2
GENINORG	EPA:351.4
GENINORG	EPA:353.1
GENINORG	EPA:353.2
GENINORG	EPA:353.3
GENINORG	EPA:365.1
GENINORG	EPA:365.2
GENINORG	EPA:365.4
GENINORG	EPA:375.4
GENINORG	EPA:376.2
GENINORG	EPA:410.1
GENINORG	EPA:410.4

Table C-5.0-1 (Continued)

Analytical Suite	Analytical Methods
GENINORG	EPA:415.1
GENINORG	Generic: ACOLR
GENINORG	Generic: CALC
GENINORG	GENERIC CONDUCTIVITY
GENINORG	Generic: FIA
GENINORG	Generic: GRAV
GENINORG	GENERIC HARDNESS
GENINORG	GENERIC IC
GENINORG	Generic:ICPES
GENINORG	GENERIC ICPES
GENINORG	GENERIC PH
GENINORG	Generic:Specific Gravity
GENINORG	Generic: TITR
GENINORG	LEGACY
GENINORG	PMM:383
GENINORG	SM:4500-F
GENINORG	SM:4500-NH3B,C
GENINORG	SM:4500-N&NH3B,C
GENINORG	SM:5310C
GENINORG	SM:A2320B
GENINORG	SM:A2340B
GENINORG	SM:A2710F
GENINORG	SW-846:6010
GENINORG	SW-846:6010B
GENINORG	SW-846:6850
GENINORG	SW846 6850 Modified
GENINORG	SW-846:8321[M]
GENINORG	SW-846:9010
GENINORG	SW-846:9010A
GENINORG	SW-846:9012A
GENINORG	SW-846:9040B
GENINORG	SW-846:9050A
GENINORG	SW-846:9056
GENINORG	SW-846:9060
GENINORG	USGS-WRI-79-4
Mercury	SW-846:7471
Mercury	SW-846:7471A
METALS	ASTM:D3972-90

Table C-5.0-1 (Continued)

Analytical Suite	Analytical Methods
Metals	EPA:200.7
Metals	EPA:200.8
Metals	EPA:206.2
Metals	EPA:245.1
Metals	EPA:245.2
Metals	EPA:270.2
Metals	EPA:370.1
Metals	GENERIC CVAA
Metals	GENERIC ETVAA
Metals	Generic: FIA
Metals	Generic:ICPES
Metals	GENERIC ICPES
Metals	Generic:ICPMS
Metals	GENERIC ICPMS
Metals	GENERIC KPA
Metals	LEGACY
Metals	SW-846:6010
Metals	SW-846:6010B
Metals	SW-846:6020
Metals	SW-846:7060
Metals	SW-846:7199
Metals	SW-846:7470
Metals	SW-846:7470A
Metals	SW-846:7471
Metals	SW-846:7471A
Metals	SW-846:7740
Perchlorate	EPA 314.0
Perchlorate	SW-846:8321A
Perchlorate	SW-846:6850

**Table C-6.0-1
Organic Chemical Analytical Methods**

Analytical Suite	Analytical Methods
DIOX/FUR	EPA:1613B
DIOX/FUR	SW-846:8280
DIOX/FUR	SW-846:8290
DIOXIN_FURAN	SW-846:8290
DRO	EPA:413.1
DRO	SW-846:8015B
DRO	SW-846:8015M_EXTRACTABLE
GRO	SW-846:8015B
GRO	SW-846:8015M_PURGEABLE
HERB	SW-846:8151A
HEXP	Generic: HE
HEXP	GENERIC HEXP
HEXP	Generic:HPLC
HEXP	LEGACY
HEXP	SW-846:8321A[M]
HEXP	SW-846:8321A_MOD
HEXP	SW-846:8330
PAH	SW-846:8310
PCB	SW-846:8082
PEST	SW-846:8081
PEST	SW-846:8081A
PEST/PCB	EPA:608
PEST/PCB	Generic: PCB
PEST/PCB	LEGACY
PEST/PCB	SW-846:8080
PEST/PCB	SW-846:8081
PEST/PCB	SW-846:8081A
PEST/PCB	SW-846:8082
SVOA	EPA:625
SVOA	Generic: SVOA
SVOA	LEGACY
SVOA	SW-846:8270
SVOA	SW-846:8270C
SVOC	SW-846:8270
SVOC	SW-846:8270C
SVOC	SW-846:8321A_MOD
VOA	EPA:624
VOA	Generic: VOA
VOA	LEGACY
VOA	SW-846:8260
VOA	SW-846:8260B
VOC	SW-846:8260B

**Table C-7.0-1
Radionuclide Analytical Methods**

Analytical Suite	Analytical Methods
AM_241	HASL-300:AM-241
GAMMA_SPEC	EPA:901.1
GAMMA_SPEC	Generic:Gamma Spec.
H3	EPA:906.0
ISO_PU	HASL-300:ISOPU
ISO_TH	HASL-300:ISOTH
ISO_U	HASL-300:ISOU
RAD	ASTM:D2216
RAD	CST:GLL
RAD	EPA:900
RAD	EPA:901.1
RAD	EPA:902
RAD	EPA:903.1
RAD	EPA:904
RAD	EPA:905.0
RAD	EPA:906.0
RAD	Generic:Alpha-Spec
RAD	Generic:Beta Counting
RAD	Generic:Gamma Spec.
RAD	Generic:Gas Flow Proportional Counting
RAD	Generic:Gas Proportional Counting
RAD	Generic: GRAV
RAD	Generic:Gross Alpha Beta Radiation
RAD	Generic:Gross Gamma
RAD	Generic:Liquid Scintillation Counting
RAD	Generic:LLEE
RAD	Generic:Low_Level_Tritium
RAD	Generic:Percent Moisture
RAD	Generic:Tritium
RAD	HASL-300:AM-241
RAD	HASL-300:I-129
RAD	HASL-300:ISOPU
RAD	HASL-300:ISOTH
RAD	HASL-300:ISOU
RAD	HASL-300:TC99
RAD	LEGACY
RAD	TIMS
SR_90	EPA:905.0

Appendix D

Contaminant Trends

D-1.0 SEDIMENT

This section presents information on contaminants in sediments in the Pajarito watershed that supports the physical system conceptual model in Section 7 and the risk assessments in Section 8. It includes information on spatial variations in the concentrations of chemicals of potential concern (COPCs) that helps identify contaminant sources and provide an understanding of the effects of sediment redistribution by floods on contaminant concentrations and potential exposure to receptors.

D-1.1 Spatial Variations in Sample Results for COPCs

Figure D-1.1-1 consists of plots showing sample results for all inorganic COPCs identified in sediment in the Pajarito watershed plotted versus distance from the Rio Grande. Figure D-1.1-2 shows the organic COPCs identified in sediment in the Pajarito watershed plotted versus distance from the Rio Grande; Figure D-1.1-3 shows radionuclides. These plots help to identify sources for the COPCs and show how concentrations change with distance from sources. Different colors on these plots are used for each subwatershed: Pajarito, Threemile, and Twomile. Each sample is plotted at a location represented by the distance from the Rio Grande to the approximate midpoint of the reach. For inorganic and organic chemicals, nondetected sample results are shown by an open circle, and the detected sample results are represented by a filled circle. For radionuclides, detect status is not indicated because radionuclide sample results are not censored. Only sediment data from the Environmental Restoration Database that have complete data packages and are validated are included in these plots.

It should be noted that the sample results in Figure D-1.1-1 are biased high as a result of biases accompanying sample collection, as discussed in Section B-1.0 of Appendix B. Specifically, samples were typically biased toward geomorphic units and sediment facies with higher concentrations of contaminants, and units and facies with low concentrations (e.g., coarse facies sediment in the active channels) are underrepresented. In addition, some of these results could not be reproduced by resampling in this investigation.

D-1.2 Average Concentrations of Select Sediment COPCs

Tables D-1.2-1 through D-1.2-8 present average concentrations of sediment COPCs in the Pajarito watershed that are discussed in Section 7.1 of this report. These calculated averages are used in the figures in Section 7.1, and they support the identification of sources for the COPCs and examination of how concentrations change with distance from sources and how they vary with sediment facies. Averages were calculated separately for fine facies sediment samples and coarse facies samples to highlight differences between concentrations in these facies. For COPCs that are significantly elevated in ash from the Cerro Grande burn area, averages were calculated separately for samples collected from pre-fire (pre-2000) sediment and post-fire sediment in reaches affected by the fire or by post-fire floods.

For inorganic and organic COPCs with nondetected sample results, upper and lower bounds on average concentrations were calculated by replacing the sample result for nondetects with either the detection limit or zero, respectively, and the midpoint or median of this range was also calculated by substituting one-half of the detection limit for nondetects. For some COPCs and some reaches, considerable uncertainty exists in average concentrations because of elevated detection limits, although for most COPCs and most reaches, uncertainties related to nondetects do not obscure the general spatial trends in COPC concentration. If improved estimates of average concentrations were warranted, these estimates could be refined using the more robust nondetect replacement methods employed in Appendix E.

D-2.0 WATER

This section presents plots showing sample results for COPCs identified in surface water, springs, alluvial groundwater, perched intermediate groundwater, and regional groundwater in the Pajarito watershed.

D-2.1 Spatial Distribution of COPCs in Surface Water and Alluvial Groundwater

This section provides information concerning the distribution of primary and mobile COPCs (perchlorate, tritium, and nitrate plus nitrite) and other constituents associated with suspended particles (iron) in the watershed using box plots that show the data for surface-water and alluvial groundwater sampling locations. Some constituents, including iron, are naturally occurring and are important in controlling the fate and transport through adsorption processes with other COPCs present in the watershed. Box plots are included for other constituents identified in Section 6 released to the watershed that are of secondary importance based on their chemical mobility and risk. The box plots convey spatial information about the watershed with surface-water and alluvial groundwater locations ordered in relation to distance from the Rio Grande. PC Spring is also included as the source of surface water upgradient of the background base flow station (PBF-B). Data collected from 2003 to 2008 under the investigations described in Section 3 are used in the box plots. The upper and lower ends of the boxes are the 75th and 25th percentiles of the data distribution; the upper and lower lines outside the boxes indicate 90th and 10th percentiles, respectively. The sampling locations included in the plots were selected to bound known or suspected contaminant sources and generally include locations that have enough data to show variability in contaminant concentrations. Nondetect values are included in the plots. The paired numbers below each box indicate the number of detects (left) and nondetects (right) at each location. Detected values are represented in the plots with filled symbols, and the nondetect values are open symbols.

Box plots for inorganics are presented in Figures D-2.1-1 through D-2.1-8 and for radionuclides in Figures D-2.1-9 and D-2.1-10.

D-2.2 Temporal Distribution of COPCs in Surface Water, and in Alluvial, Perched Intermediate and Regional Groundwater

This section provides additional information concerning the time-varying concentrations of COPCs in water using time-series plots. Concentrations as a function of time are presented for alluvial groundwater at 9 alluvial wells, for perched intermediate groundwater at 4 intermediate wells, for regional groundwater at 6 regional wells, and for groundwater at 15 springs. At each location, the full period of record for a given constituent is presented with the following exceptions. Tritium is represented by low-level analyses beginning in 2000 with a method detection limit (MDL) of 0.3 pCi/L. Tritium analyzed by liquid scintillation counting has an MDL of 300 picocuries per liter (pCi/L). Some of the historic results for tritium analyzed by liquid scintillation counting produced highly variable positive and negative values that distort the scale and hide the trend of recent results. Analytical results for perchlorate are represented by both standard analysis with an MDL of 3 µg/L for 2000–2003 and by low-level analyses with an MDL of 0.05 µg/L for 2004–2008. The new alluvial wells that were sampled for the first time in June 2008 (PCAO-5, PCAO-7a, PCAO-7b2, PCAO-8, and PCAO-9) are not presented in the time-series plots in D-2.2 but are included in the box plots in D-2.1. Wells that have undergone rehabilitation (R-20 and R-32) are shown for the period since the rehabilitation.

Temporal distribution plots for alluvial wells are presented in Figures D-2.2-1 through D-2.2-54, plots for perched intermediate wells are in Figures D-2.2-55 through D-2.2-81, plots for regional wells are in Figures D-2.2-82 through D-2.2-117, and plots for springs are in Figures D-2.2-118 through D-2.2-207.

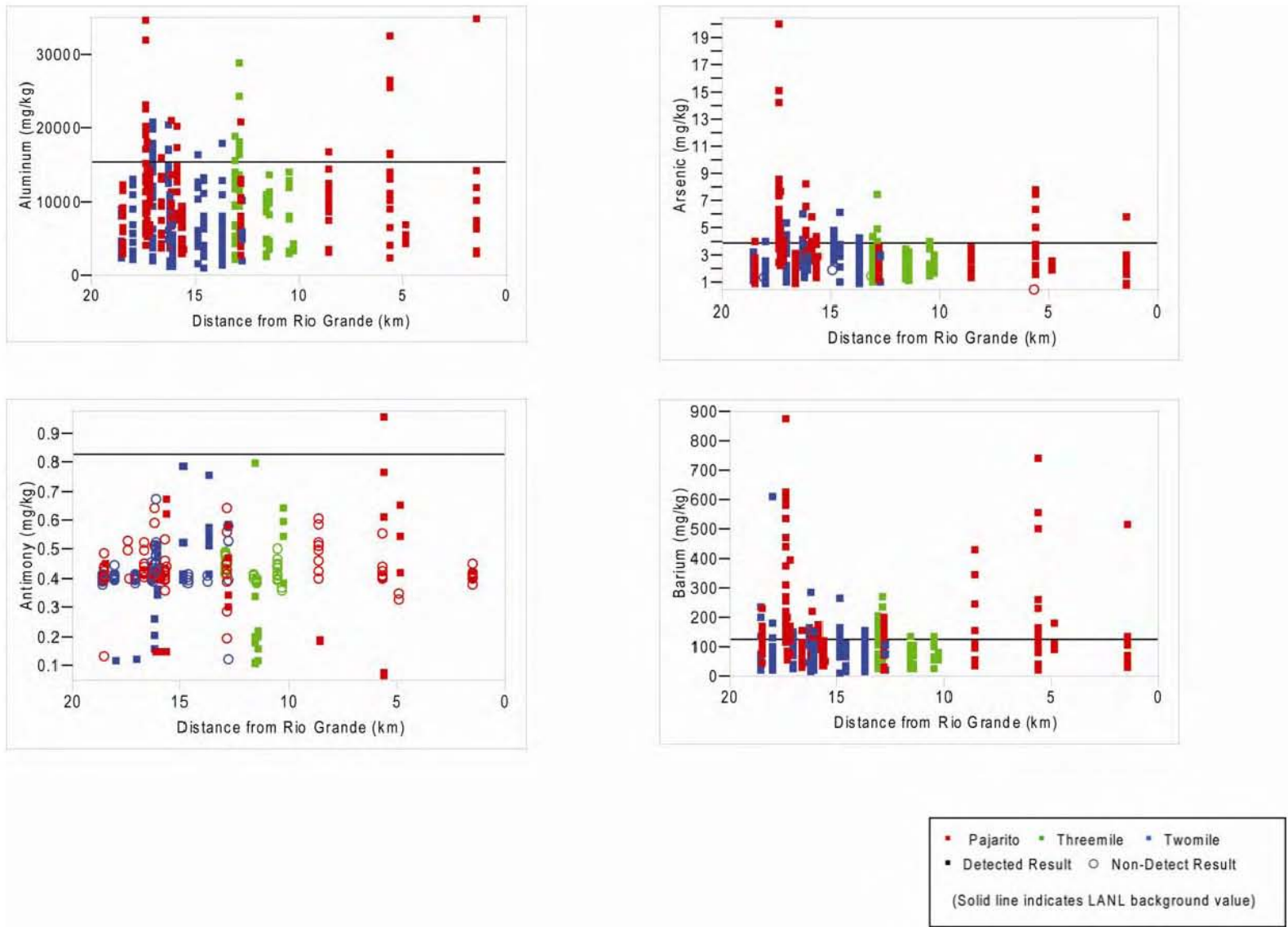

Figure D-1.1-1 Plots of sample results versus distance from the Rio Grande for all inorganic COPCs identified in sediment in the Pajarito watershed

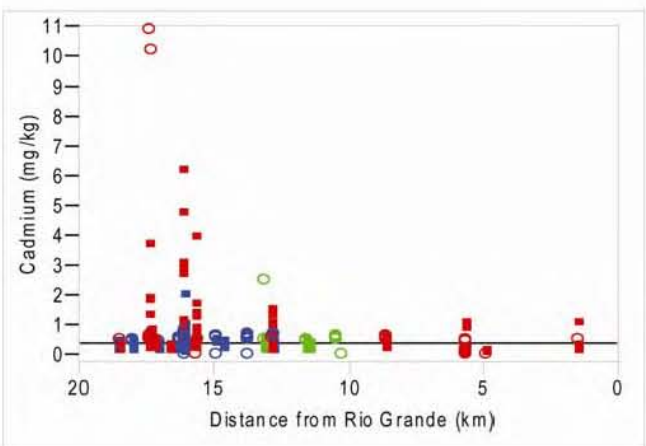
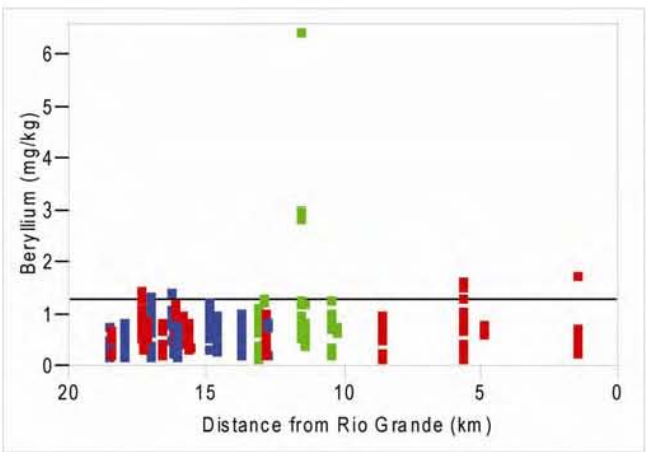
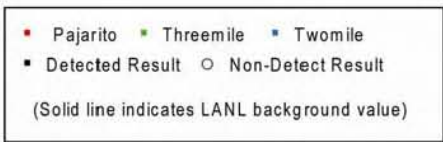
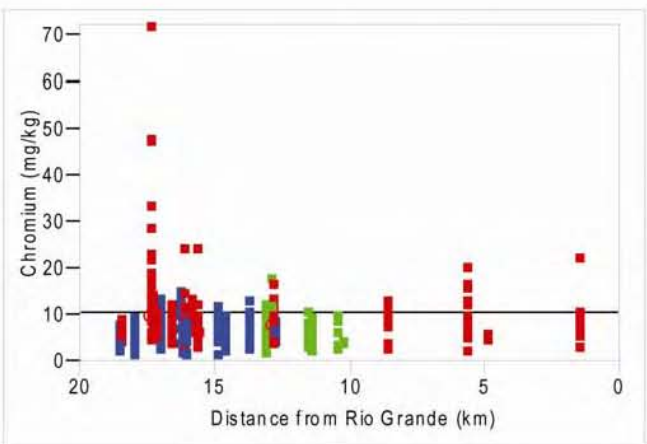
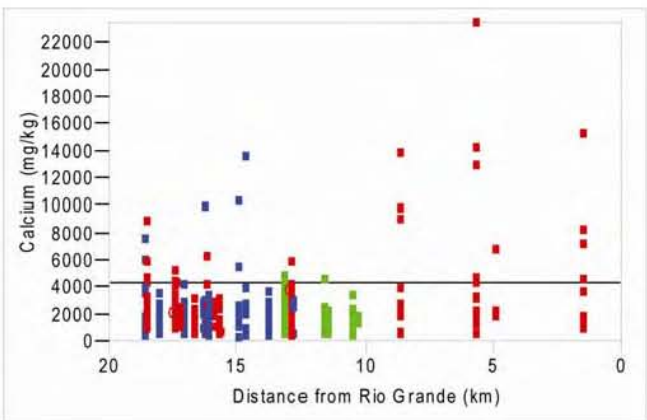

Figure D-1.1-1 (continued)

September 2008

D-4

EP2008-0450

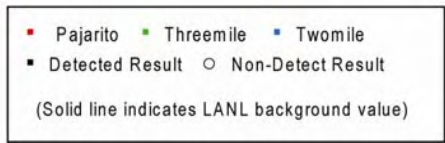
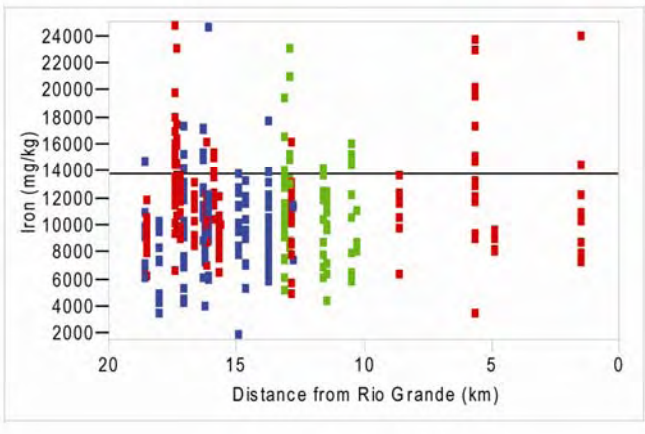
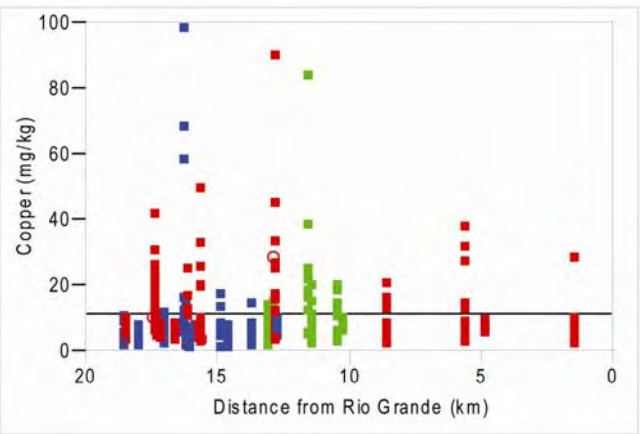
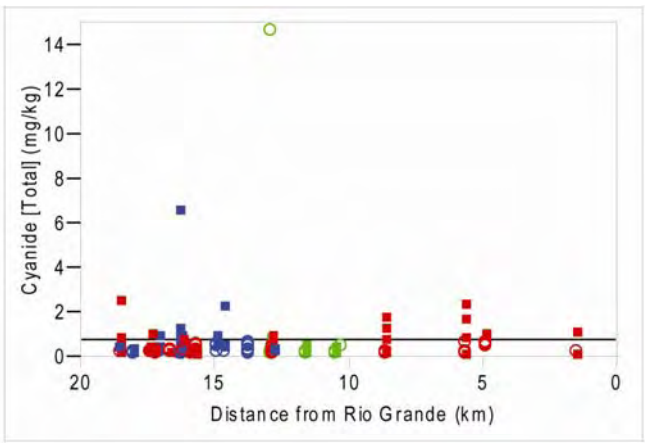
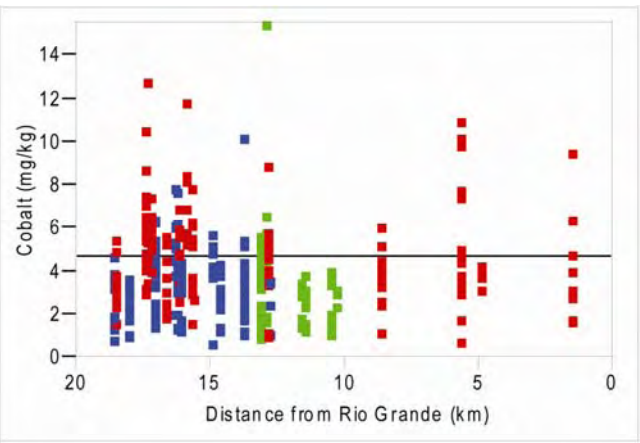
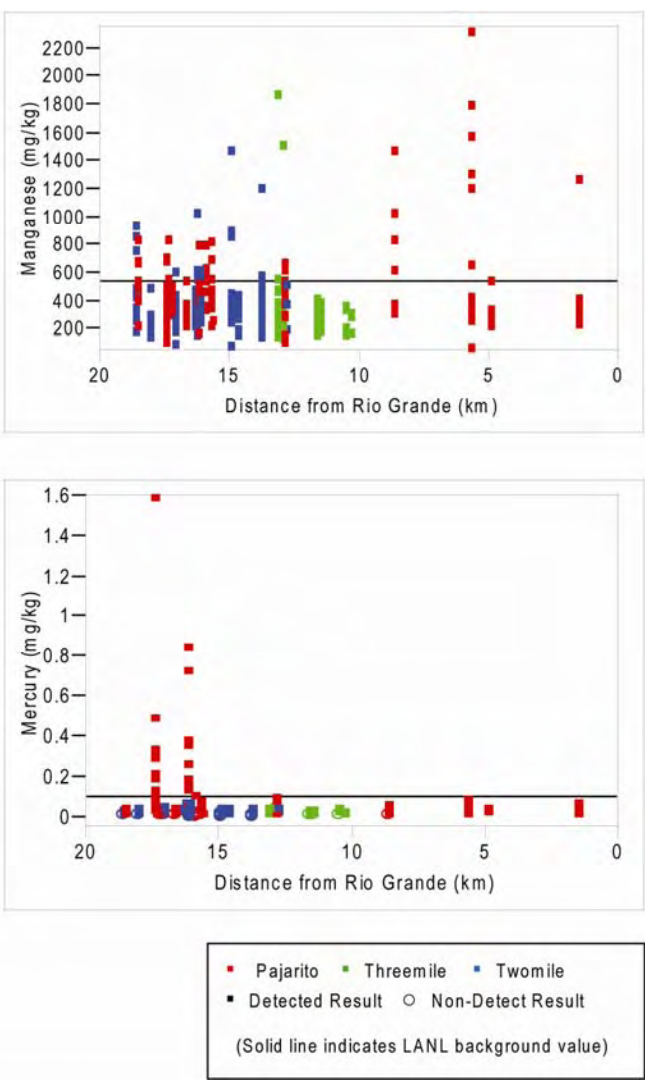

Figure D-1.1-1 (continued)



September 2008

D-6

Figure D-1.1-1 (continued)

EP2008-0450

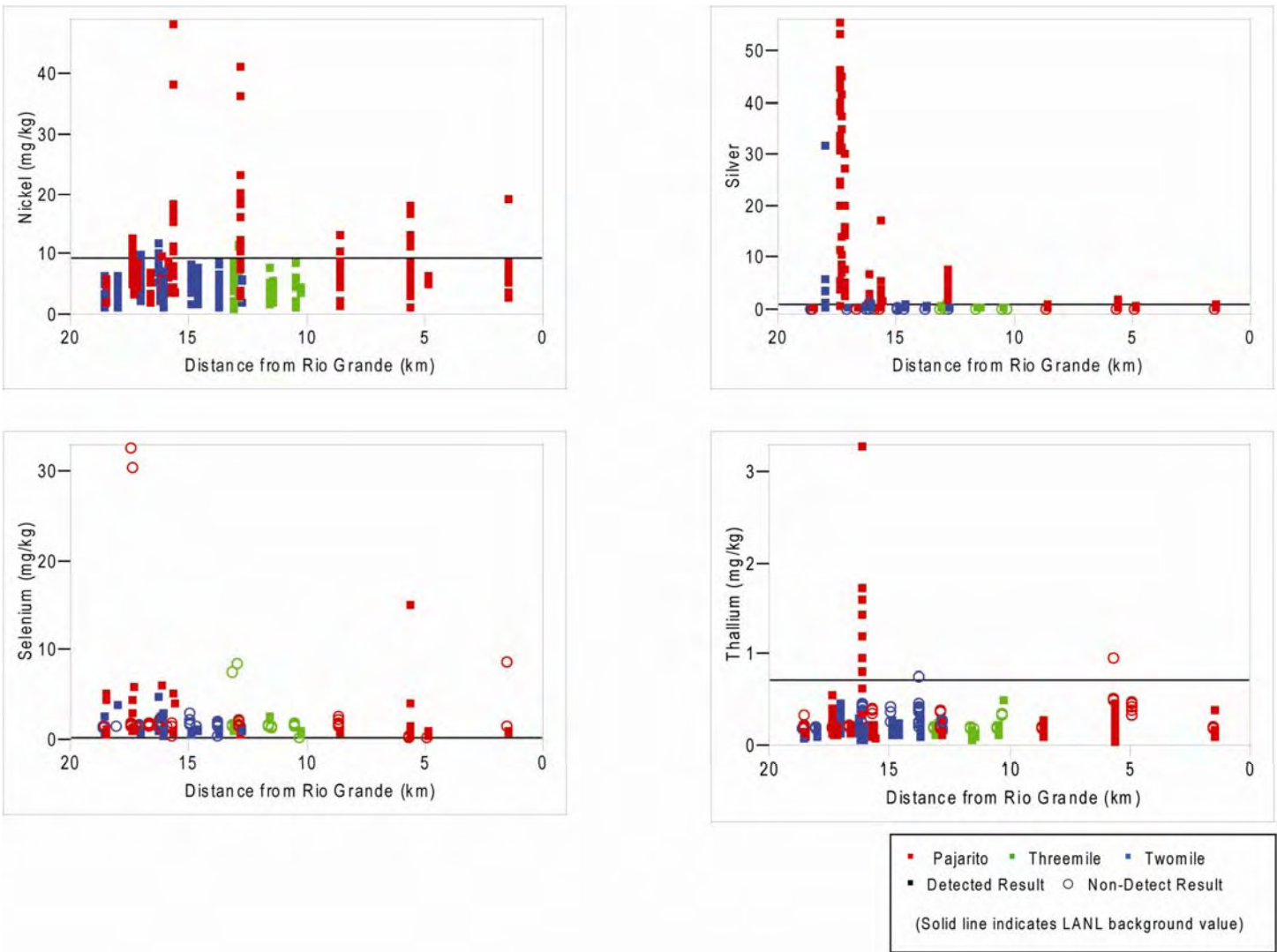

Figure D-1.1-1 (continued)

September 2008

D-8

EP2008-0450

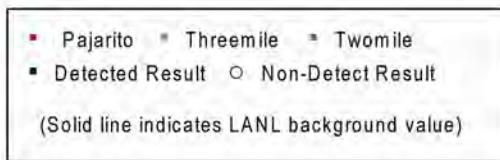
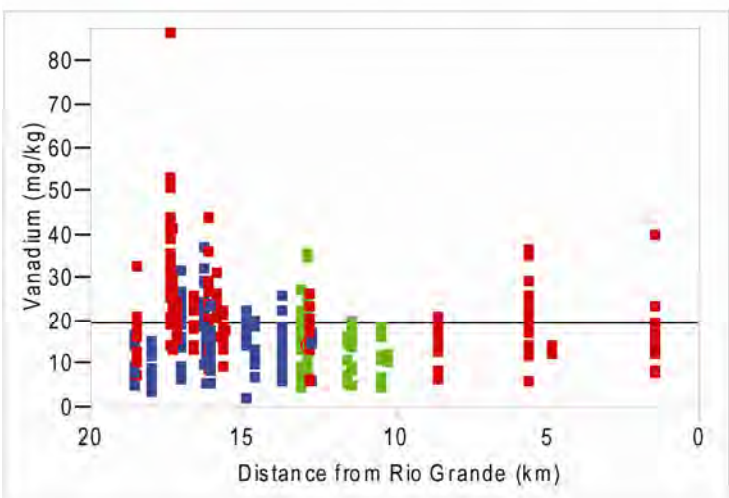
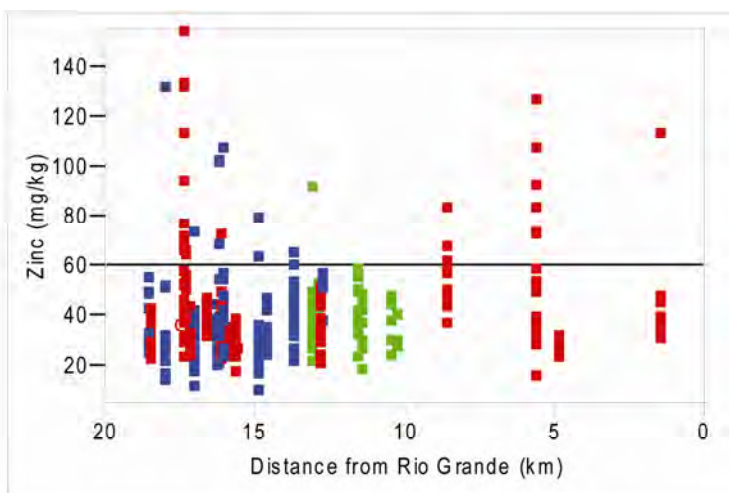
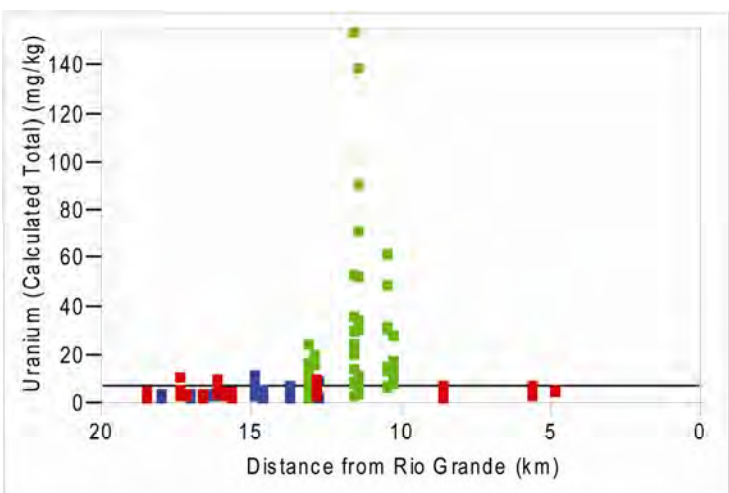

Figure D-1.1-1 (continued)

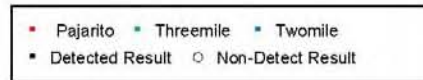
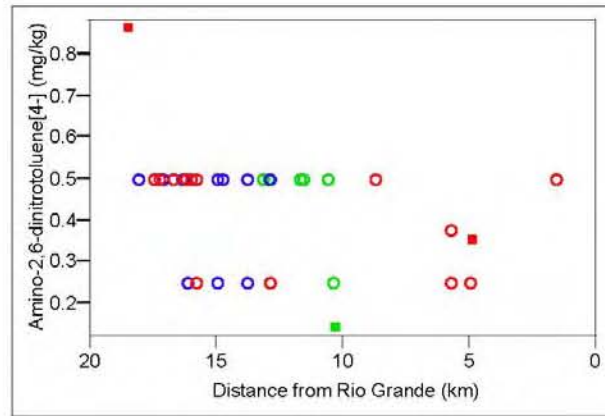
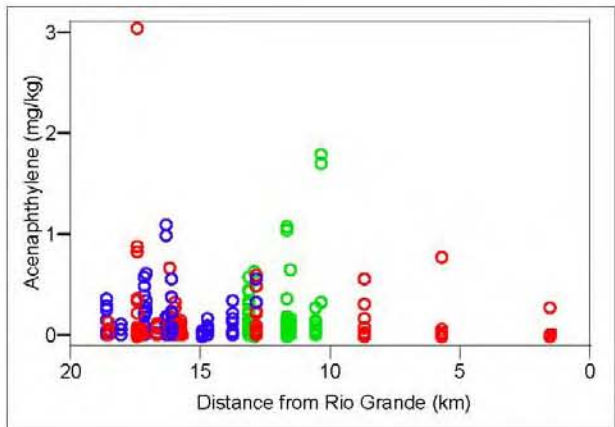
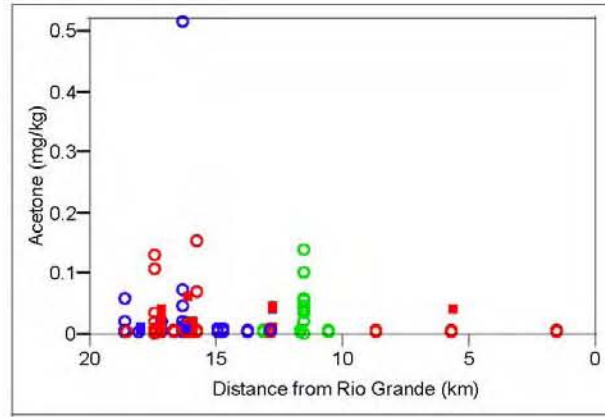
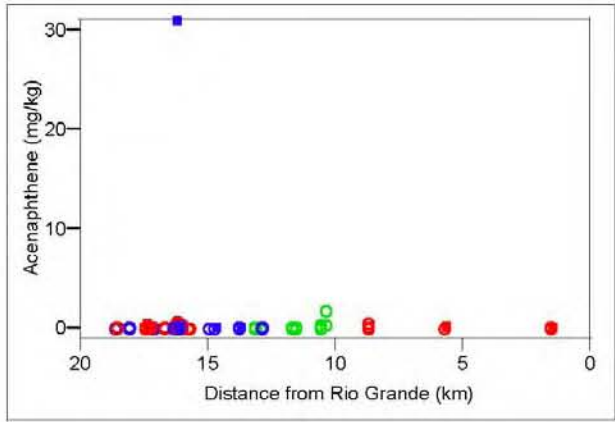

Figure D-1.1-2 Plots of sample results versus distance from the Rio Grande for all organic COPCs identified in sediment in the Pajarito watershed

September 2008

D-10

EP2008-0450

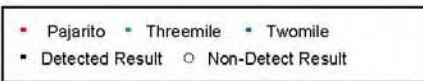
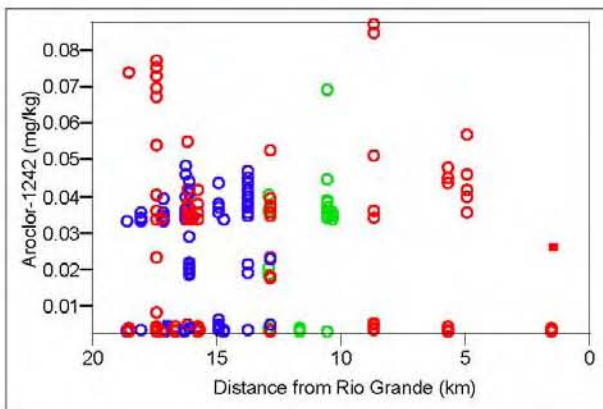
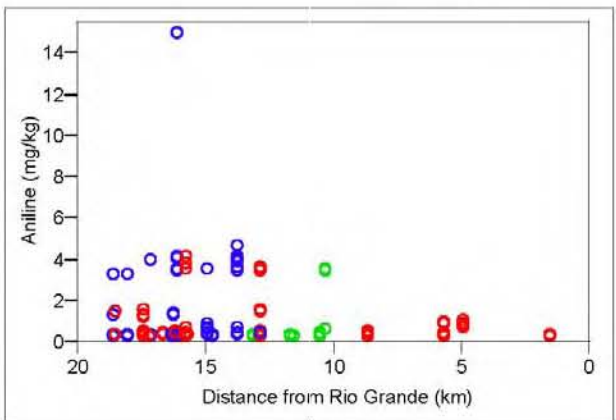
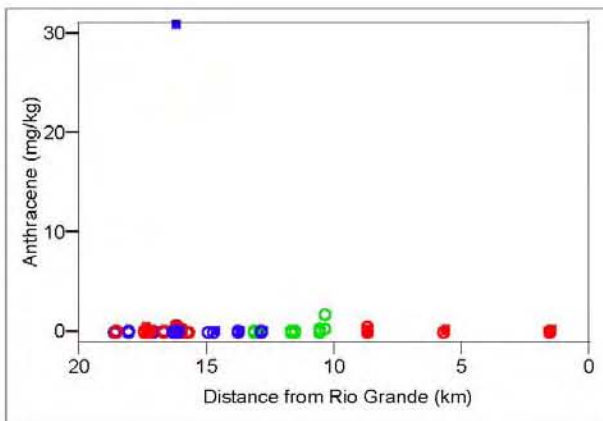
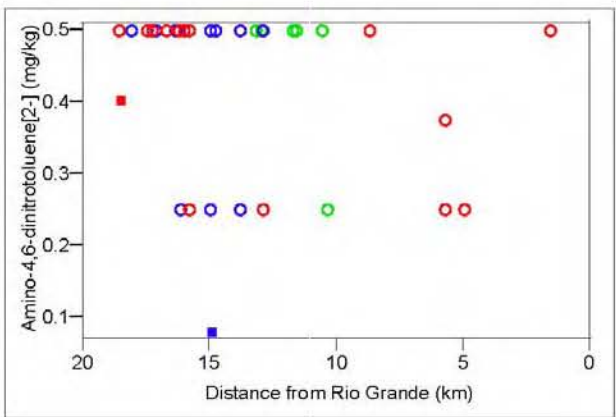

Figure D-1.1-2 (continued)

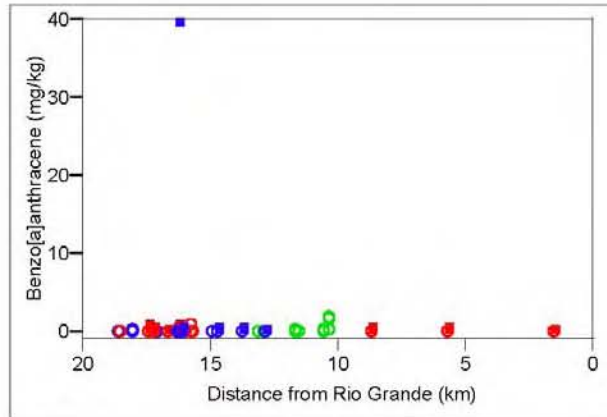
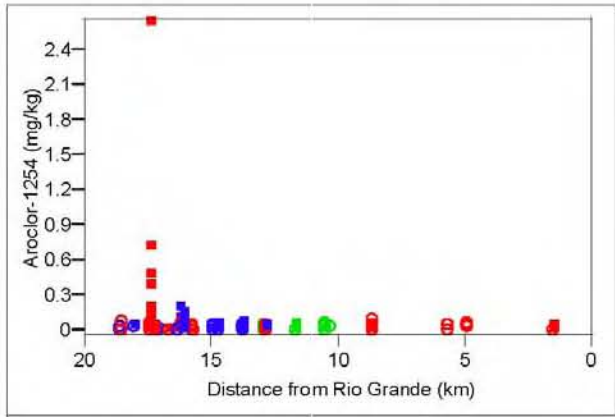
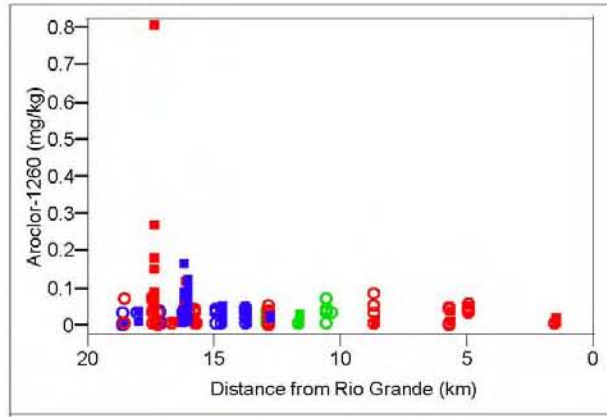
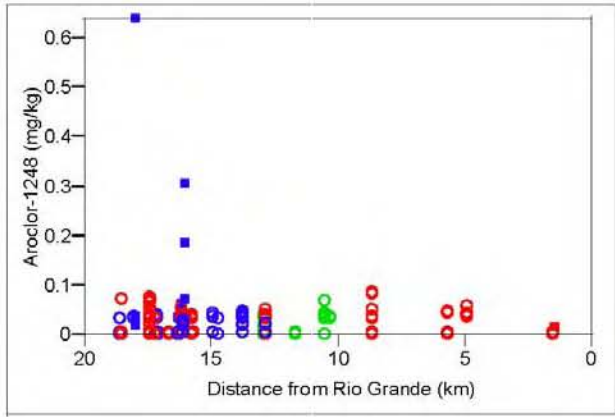

Figure D-1.1-2 (continued)

September 2008

D-12

EP2008-0450

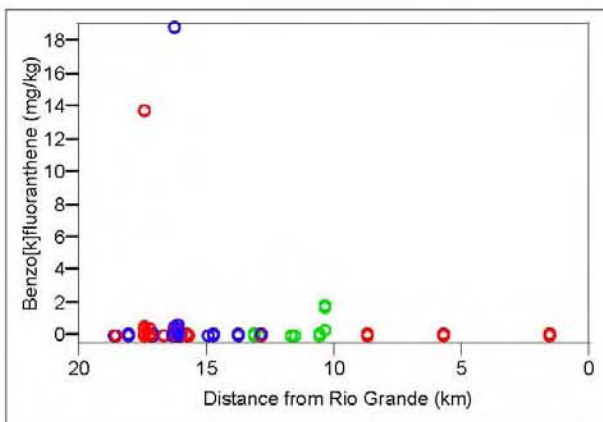
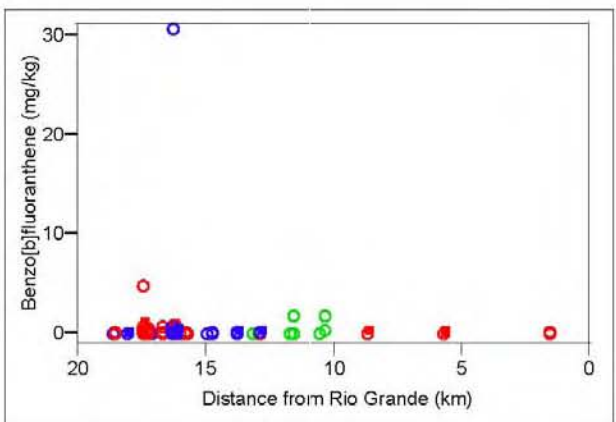
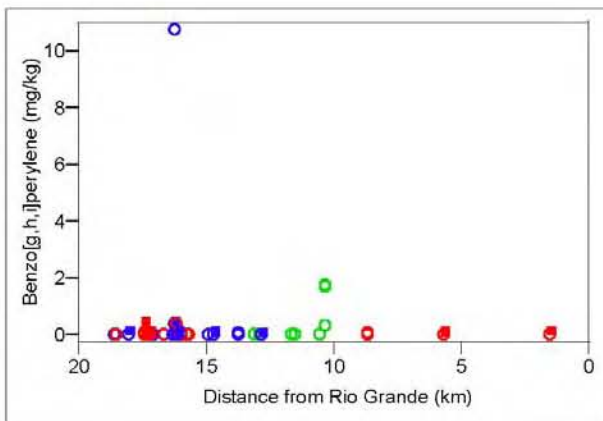
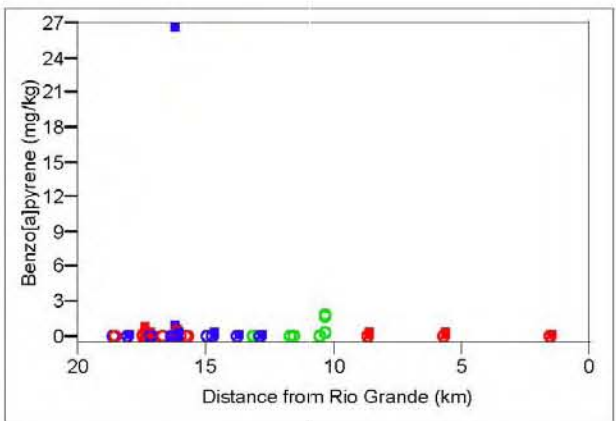

Figure D-1.1-2 (continued)

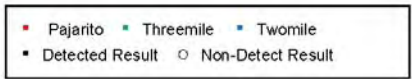
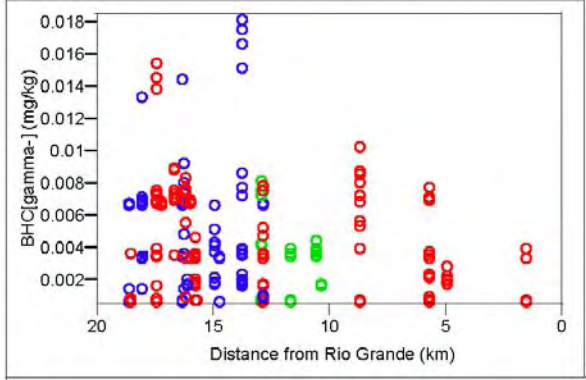
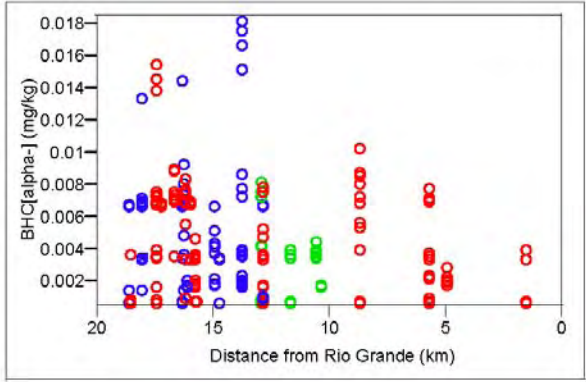
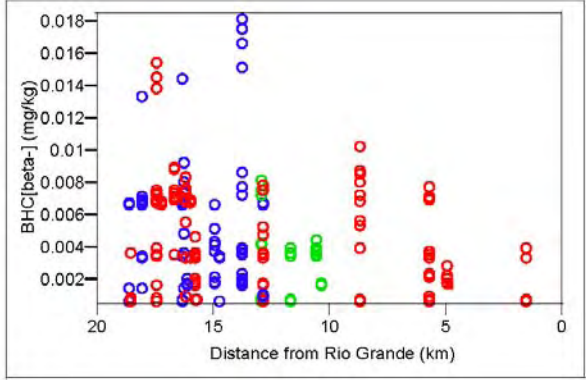
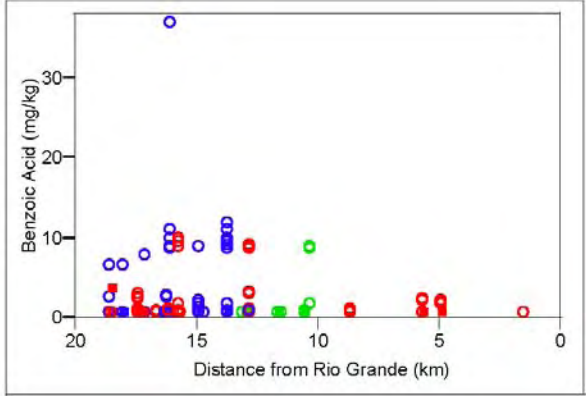

Figure D-1.1-2 (continued)

September 2008

D-14

EP2008-0450

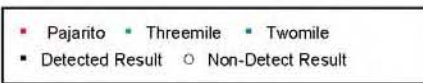
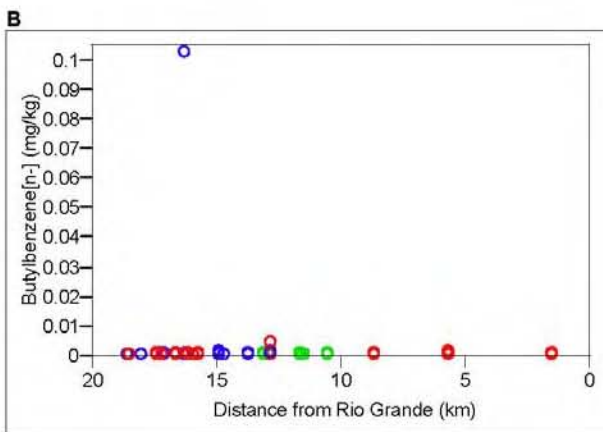
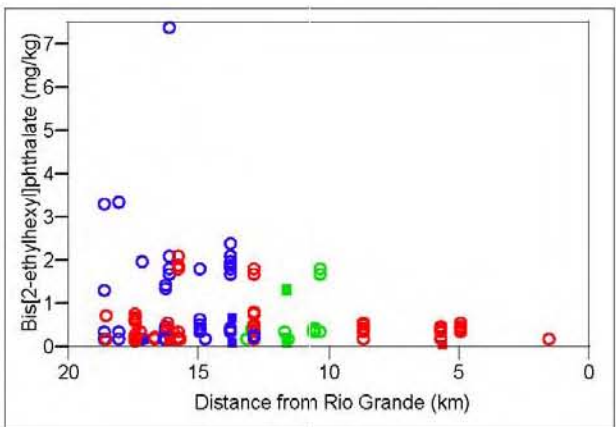
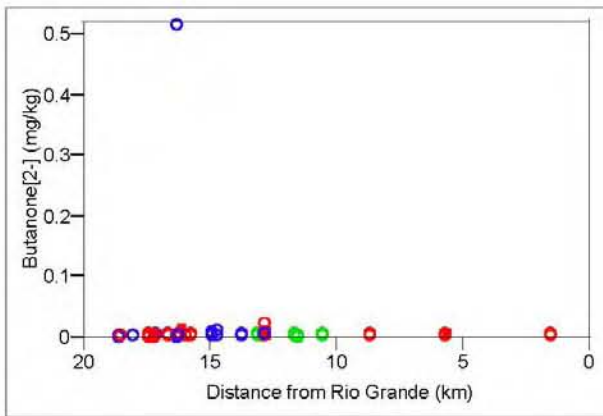
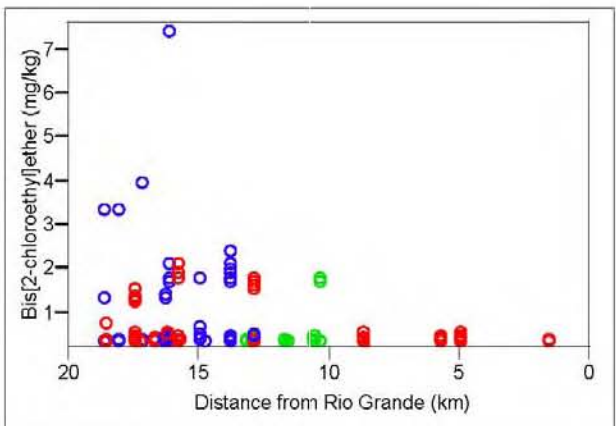

Figure D-1.1-2 (continued)

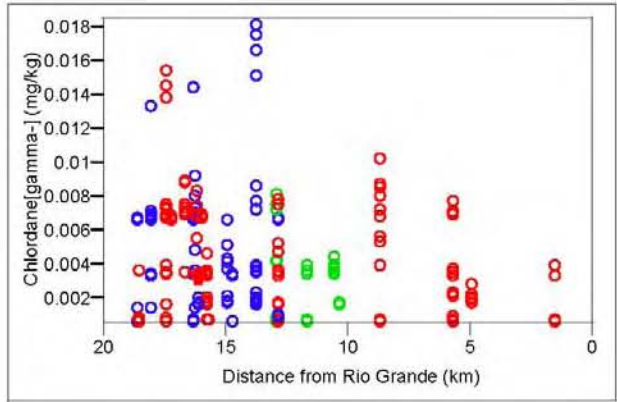
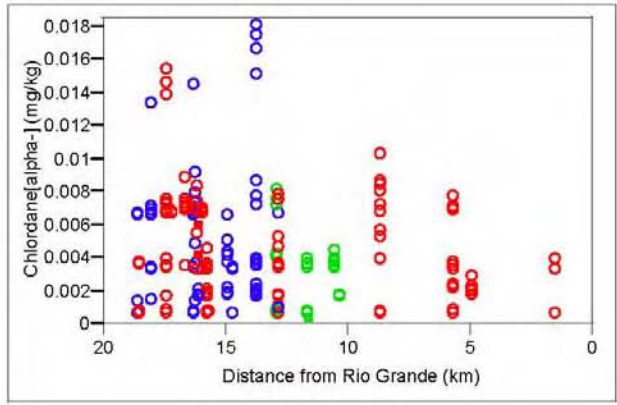
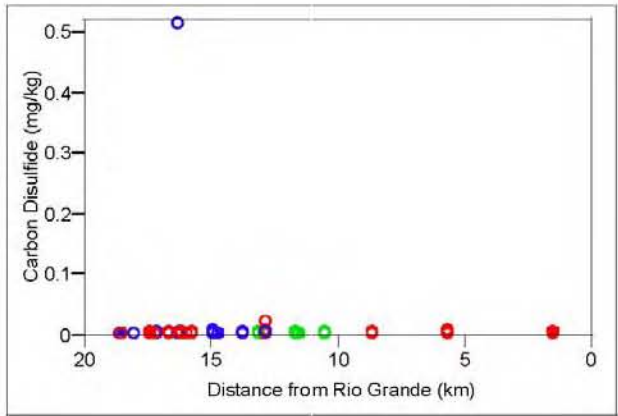
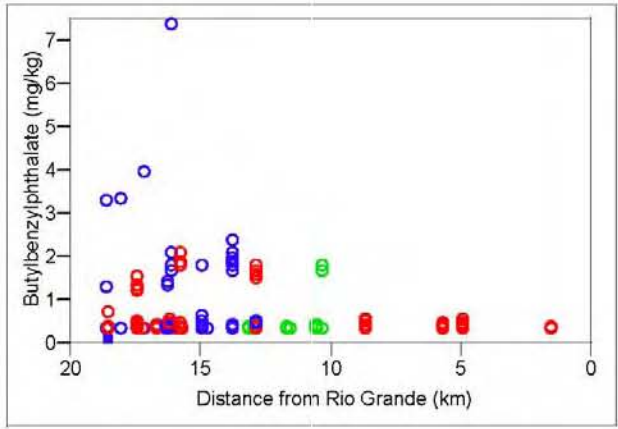

Figure D-1.1-2 (continued)

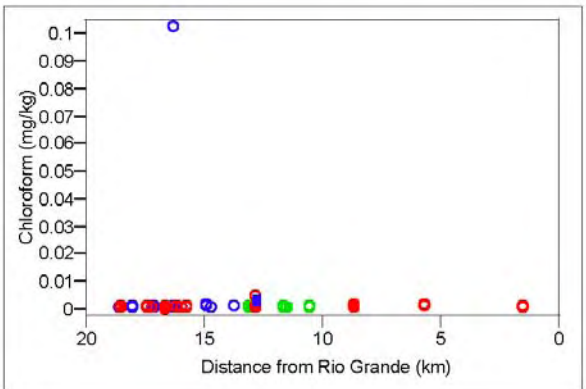
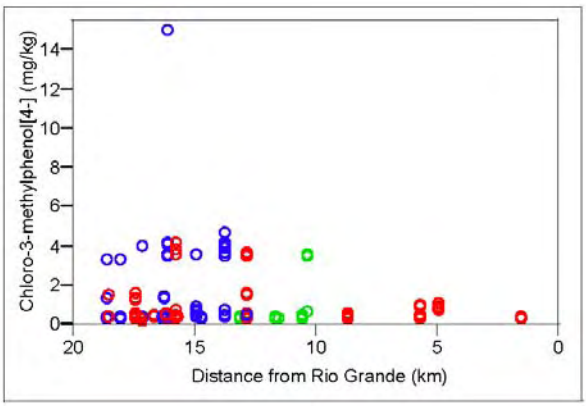
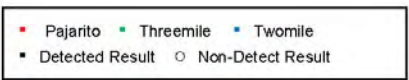
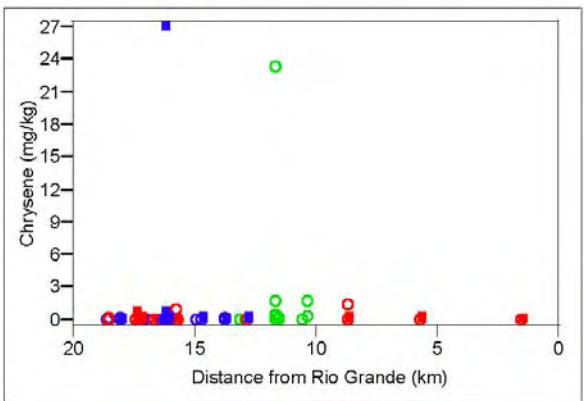
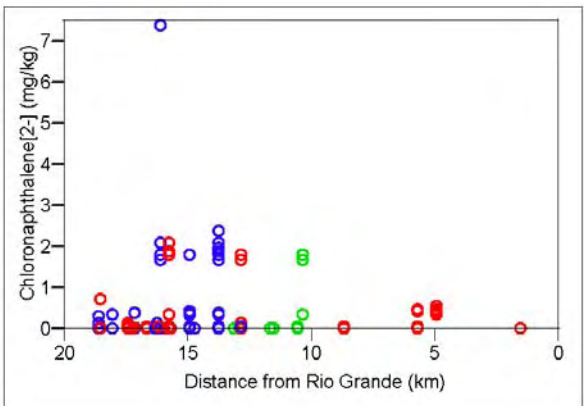

Figure D-1.1-2 (continued)

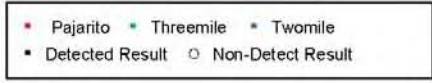
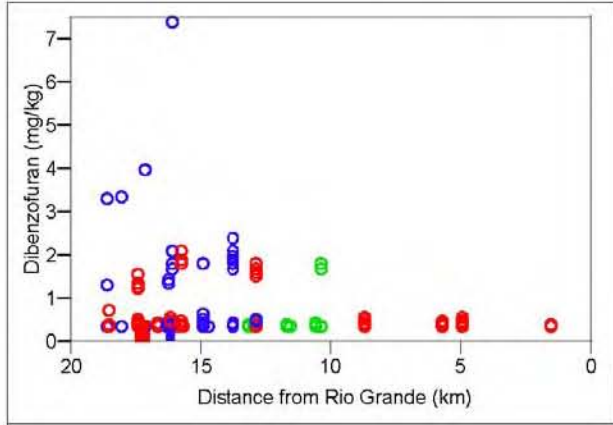
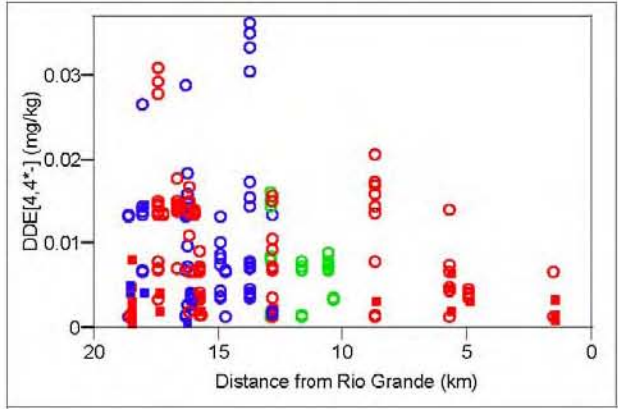
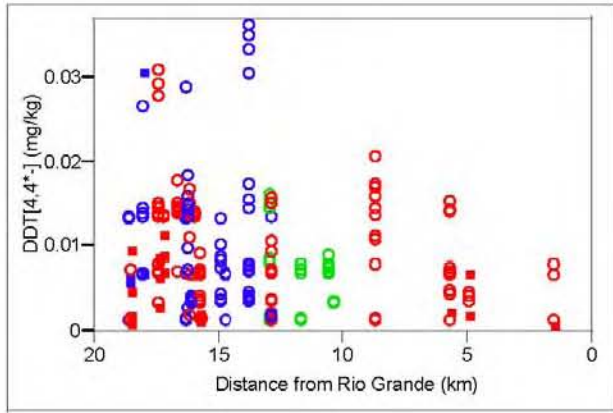
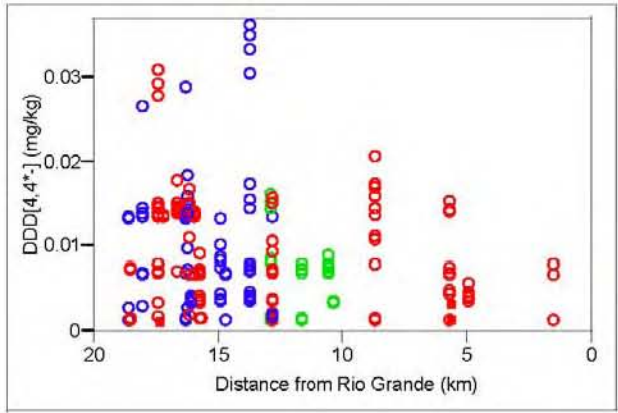

Figure D-1.1-2 (continued)

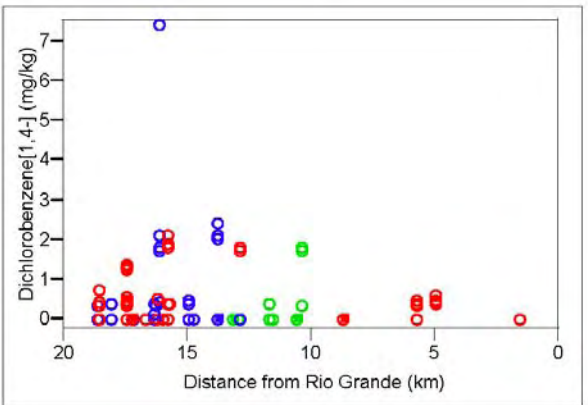
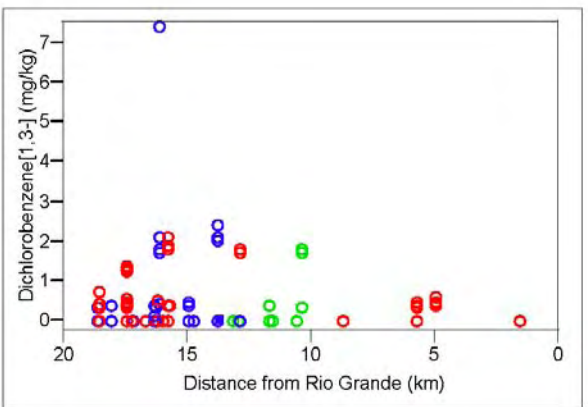
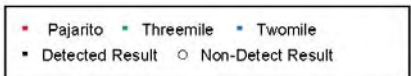
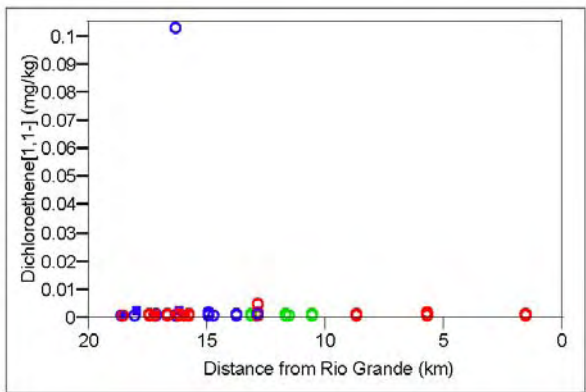
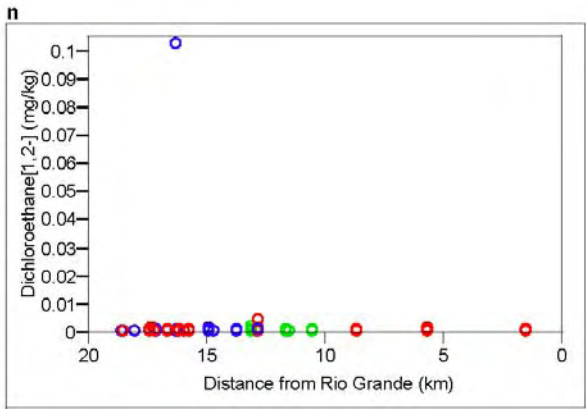

Figure D-1.1-2 (continued)

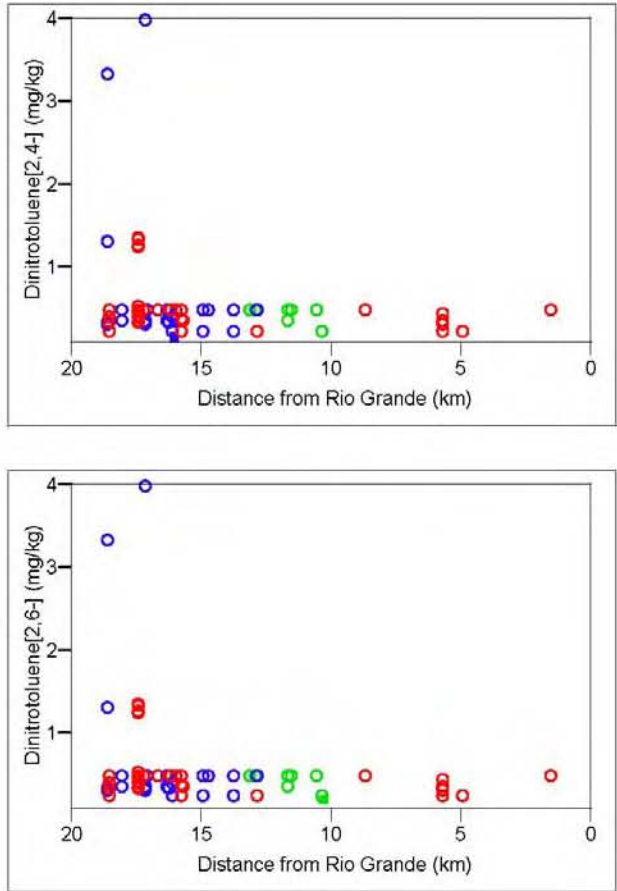
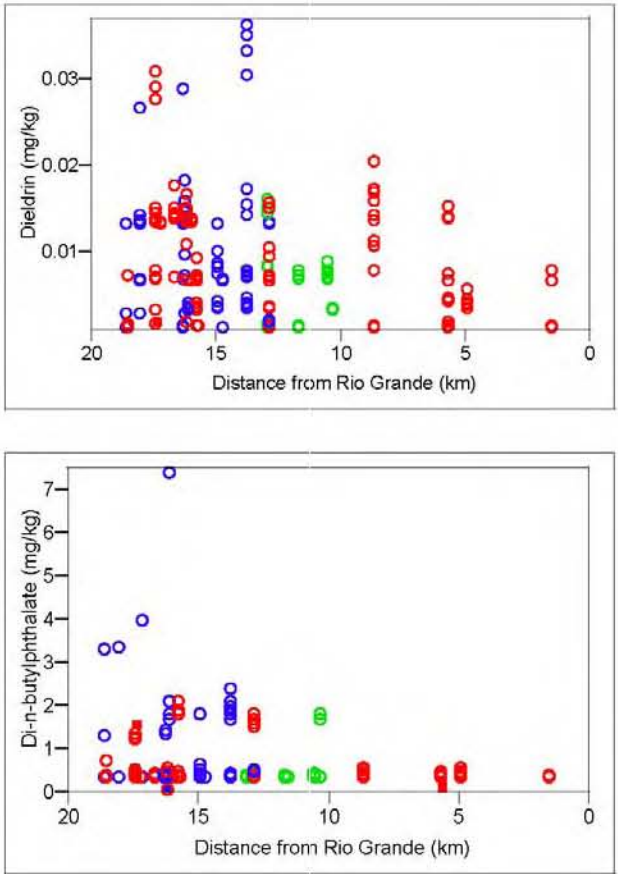

Figure D-1.1-2 (continued)

September 2008

D-20

EP2008-0450

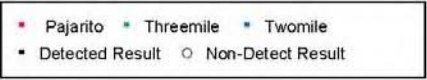
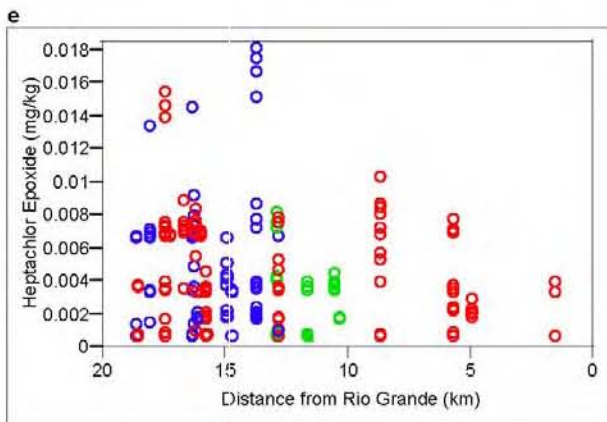
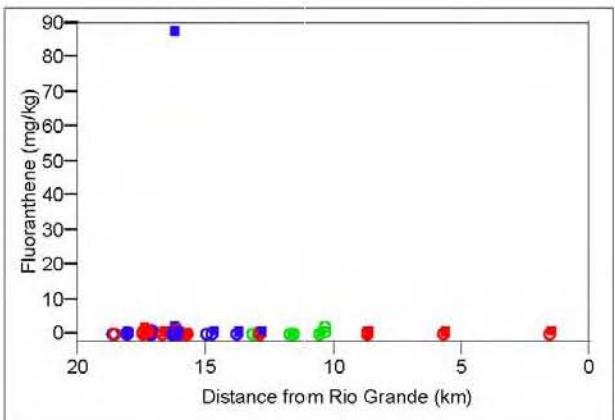
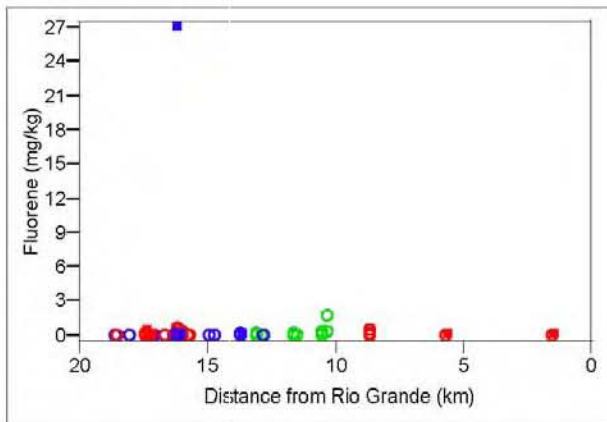
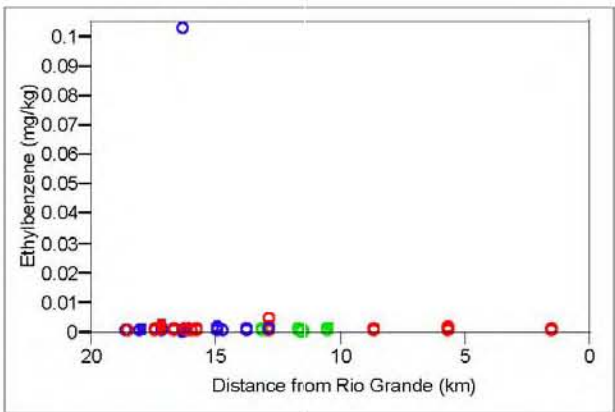

Figure D-1.1-2 (continued)

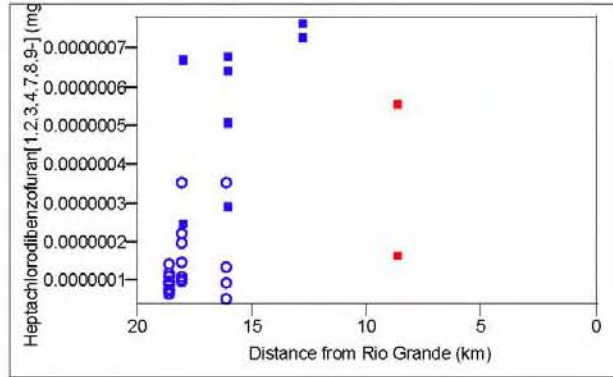
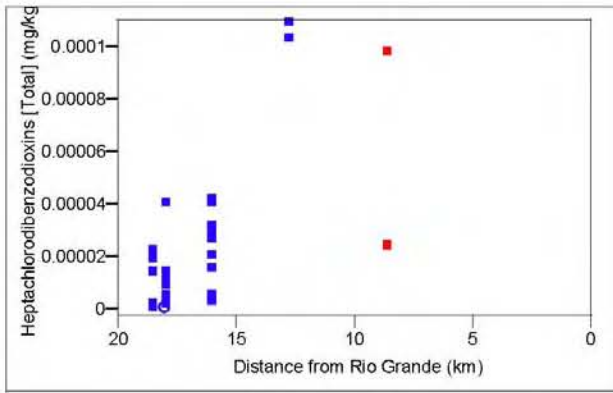
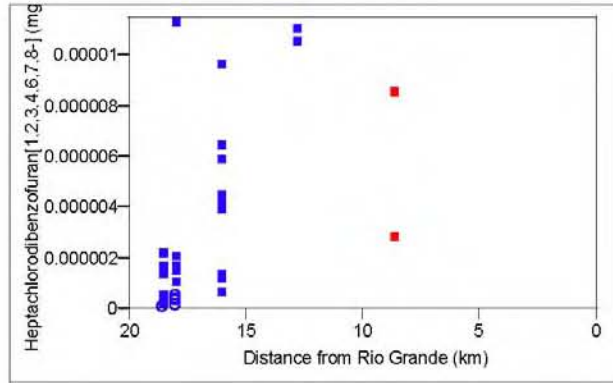
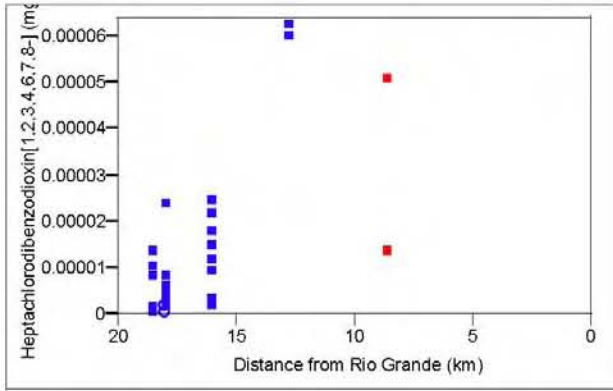

Figure D-1.1-2 (continued)

September 2008

D-22

EP2008-0450

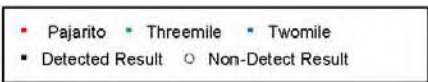
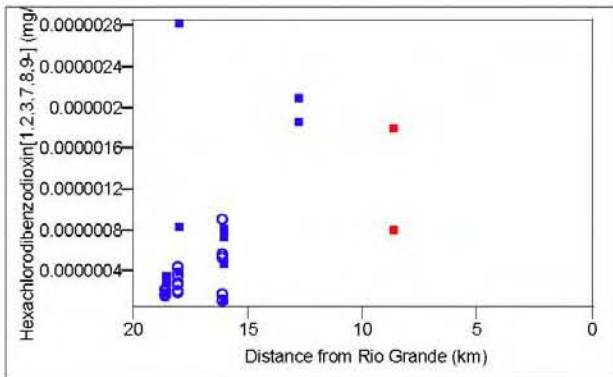
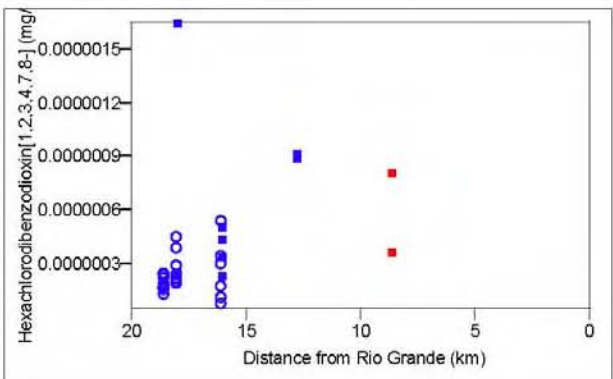
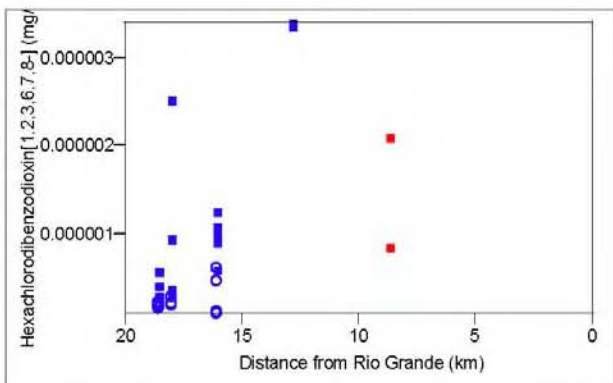
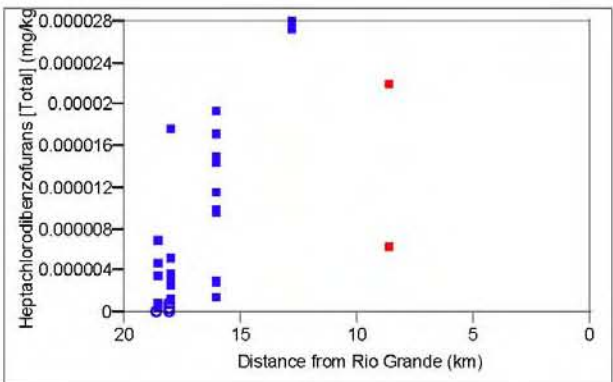

Figure D-1.1-2 (continued)

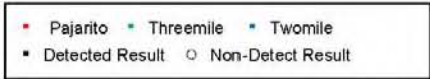
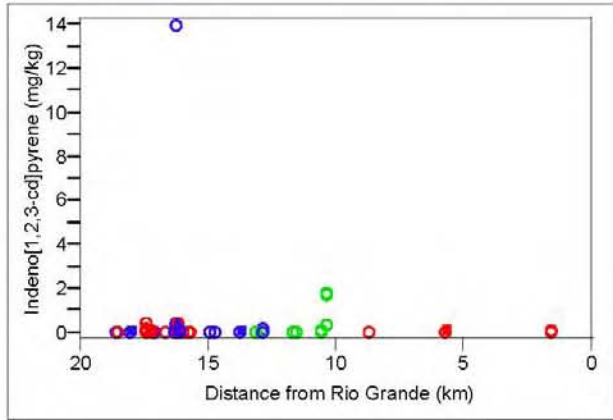
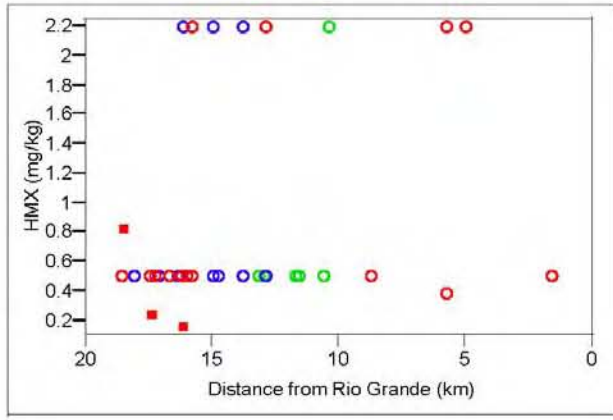
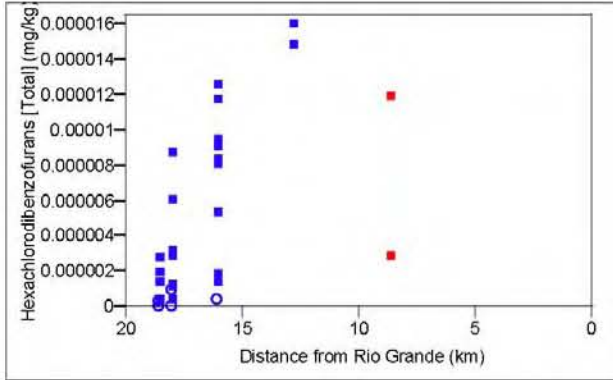
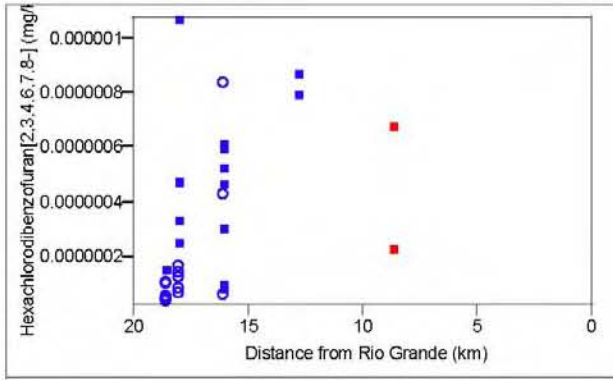

Figure D-1.1-2 (continued)

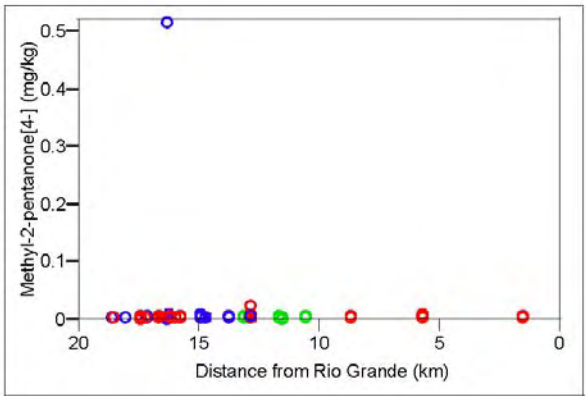
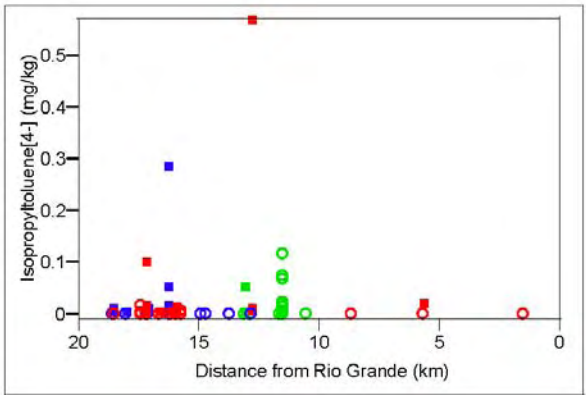
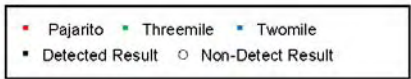
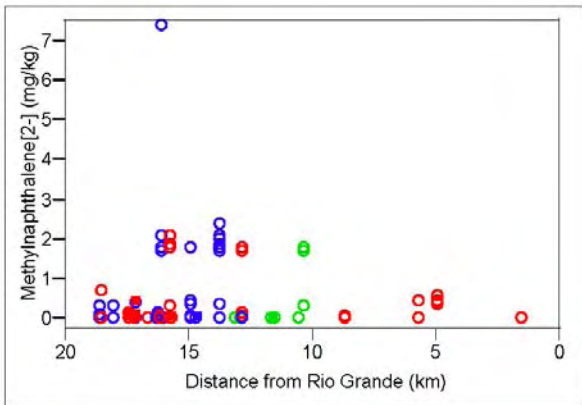
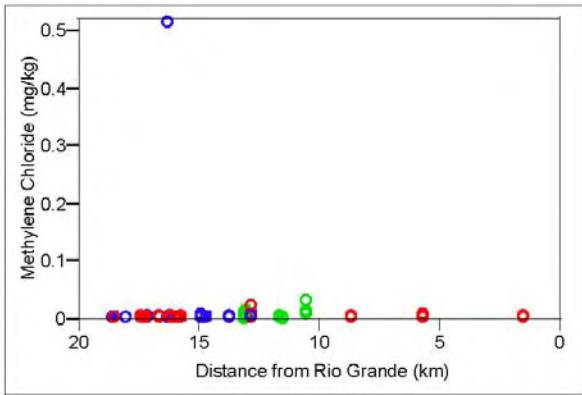

Figure D-1.1-2 (continued)

September 2008

D-24

EP2008-0450

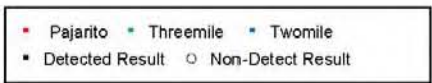
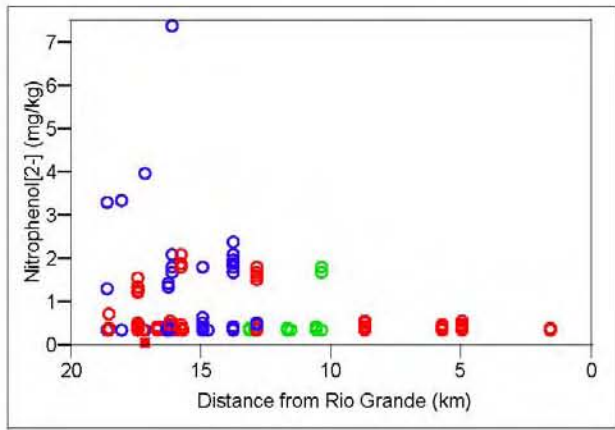
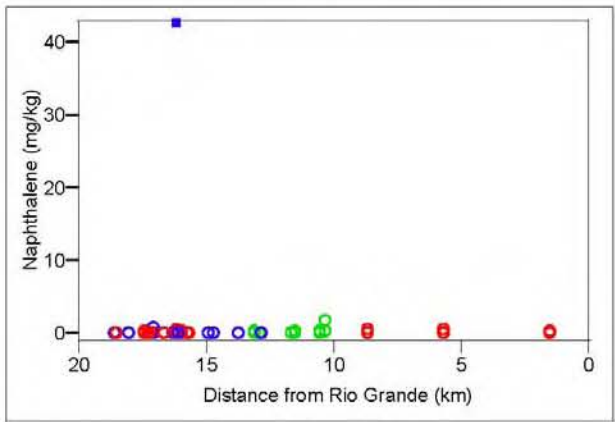
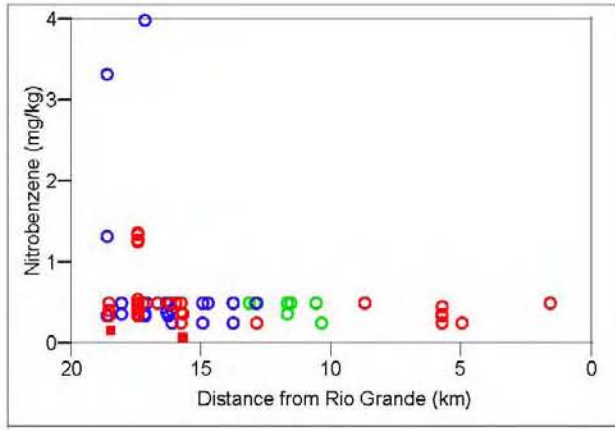
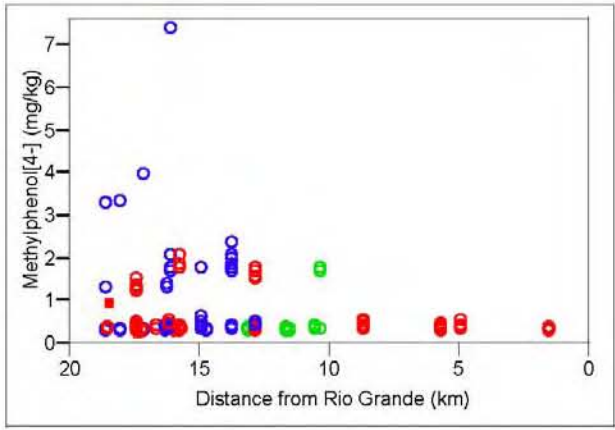

Figure D-1.1-2 (continued)

September 2008

D-26

EP2008-0450

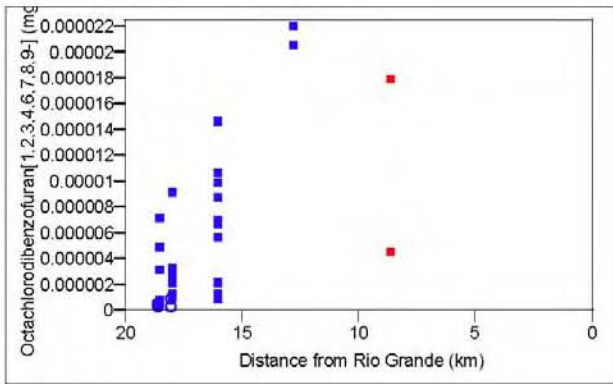
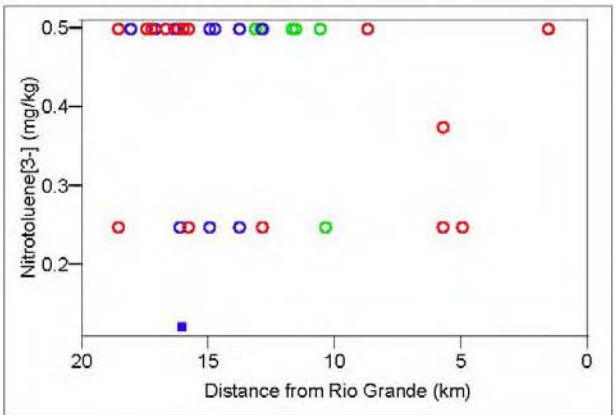
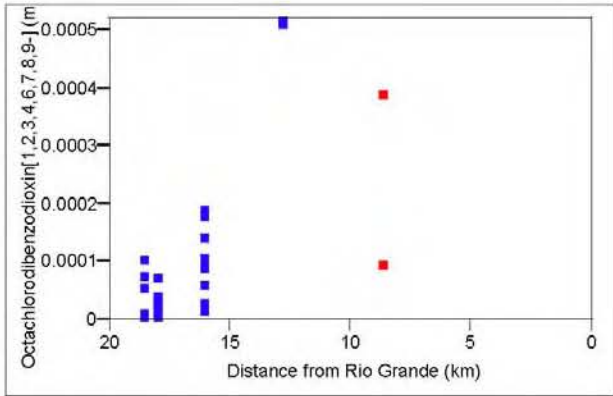
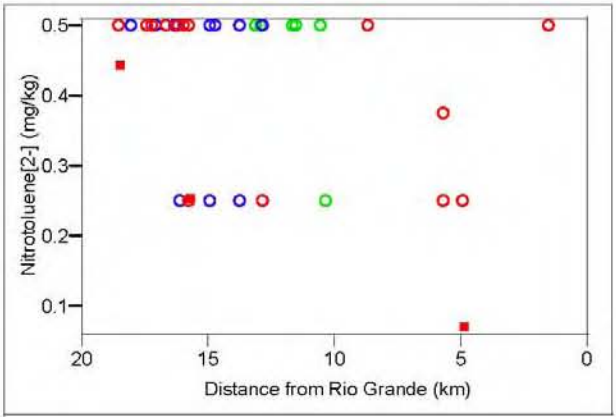

Figure D-1.1-2 (continued)

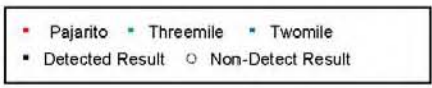
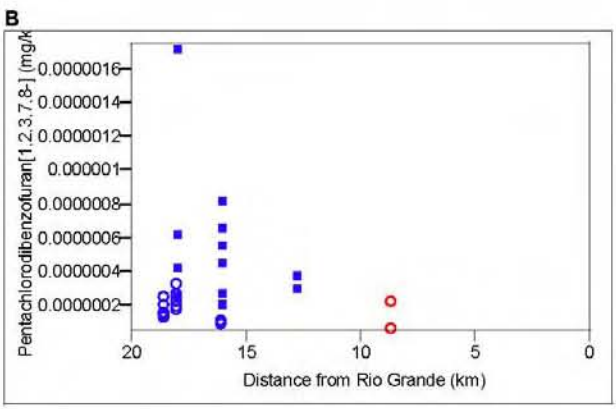
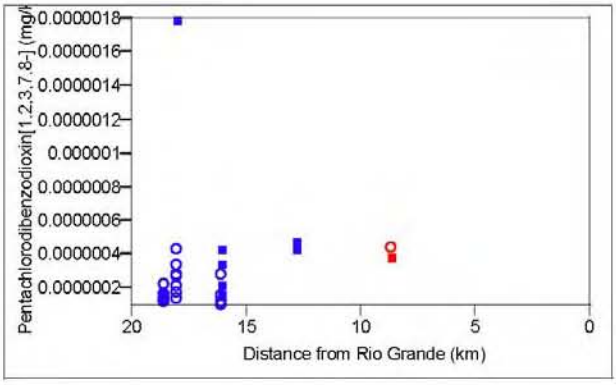
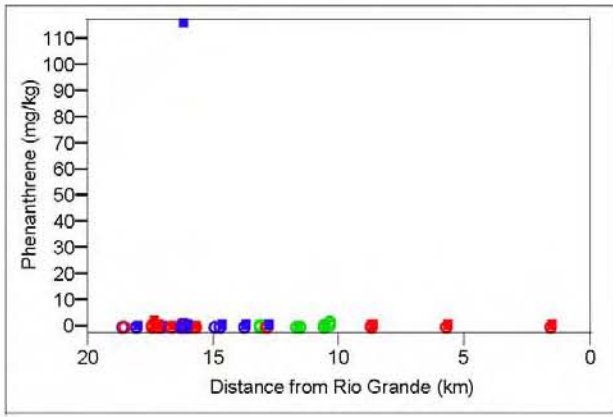
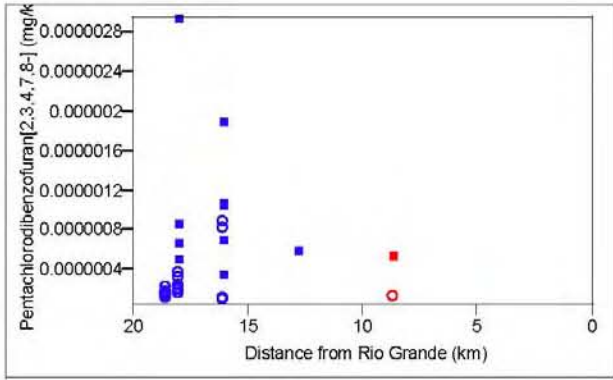

Figure D-1.1-2 (continued)

September 2008

D-28

EP2008-0450

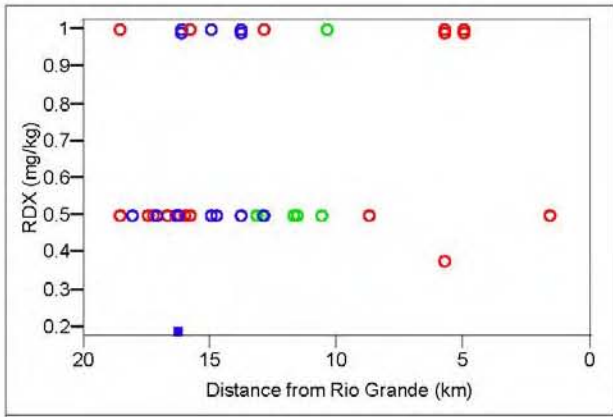
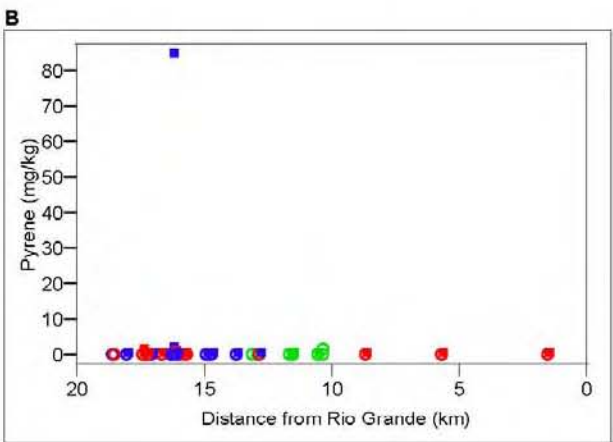
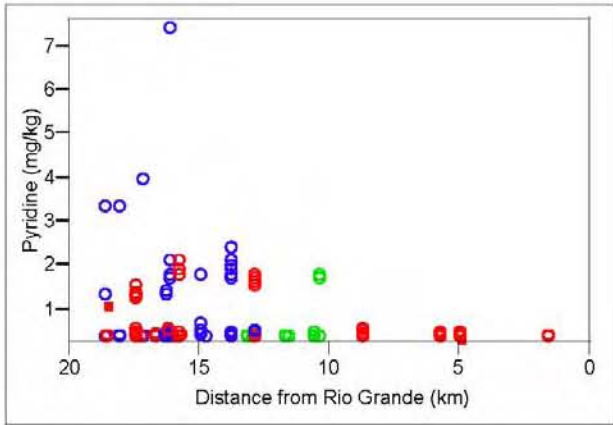
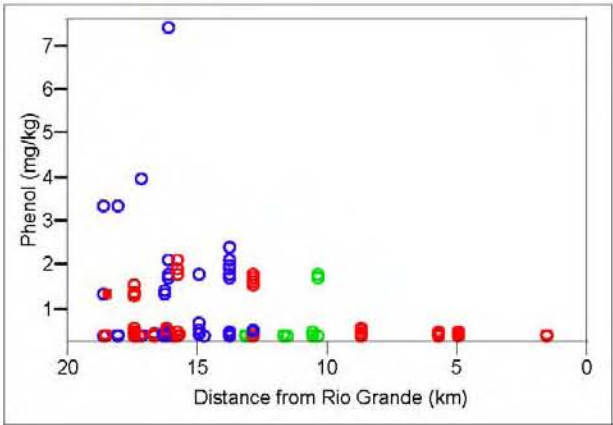

Figure D-1.1-2 (continued)

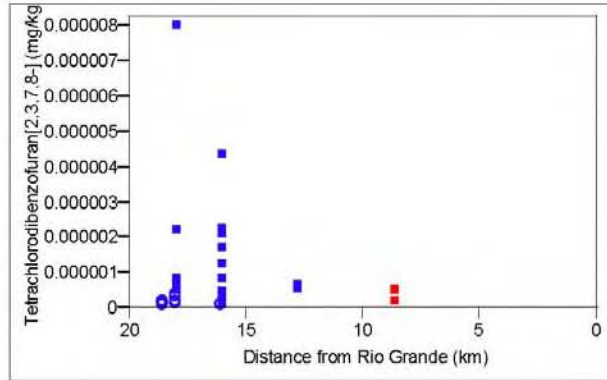
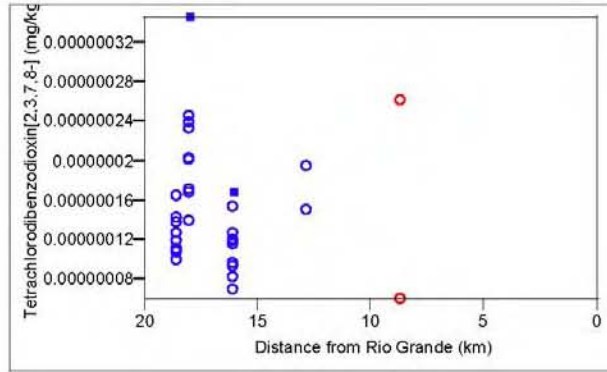
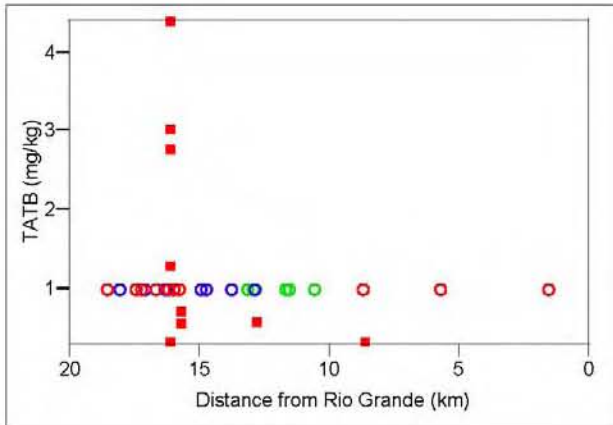
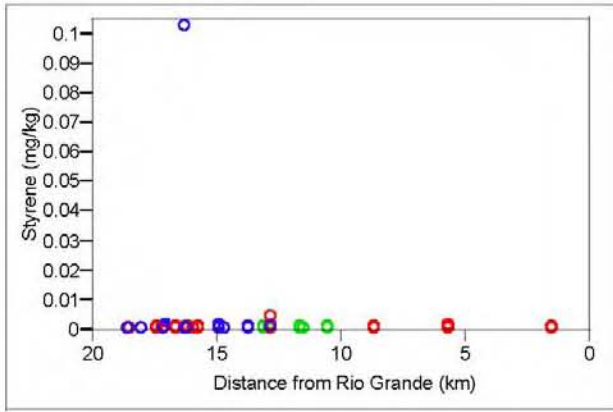

Figure D-1.1-2 (continued)

September 2008

D-30

EP2008-0450

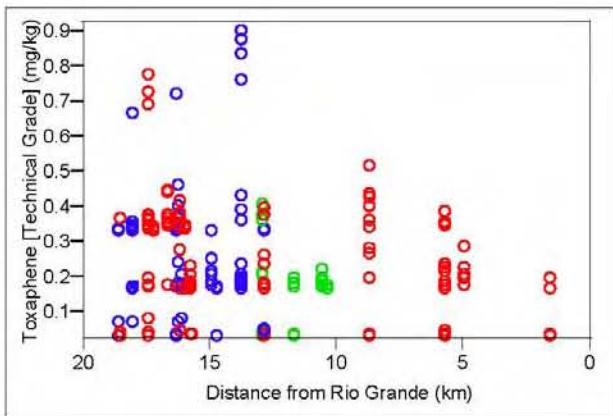
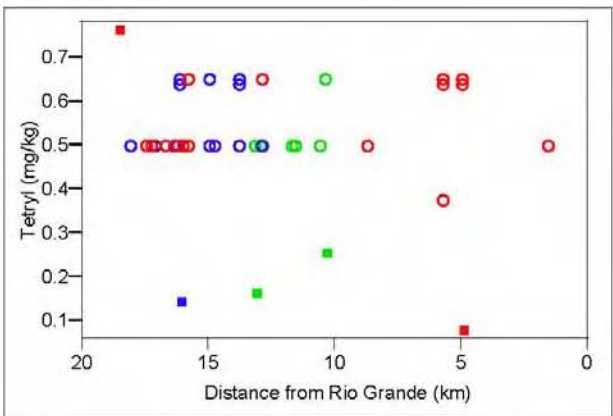
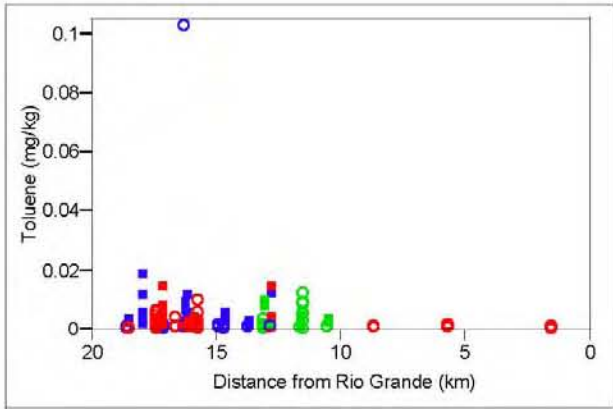
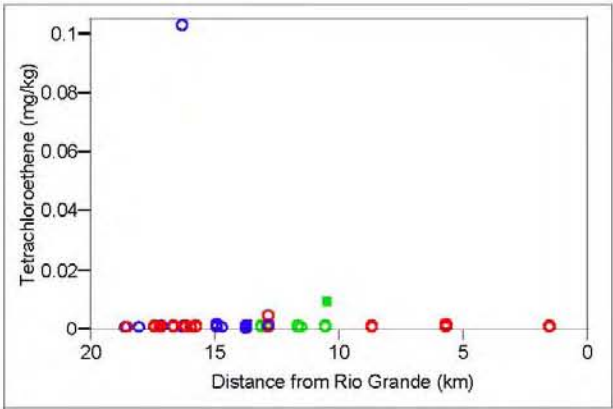

Figure D-1.1-2 (continued)

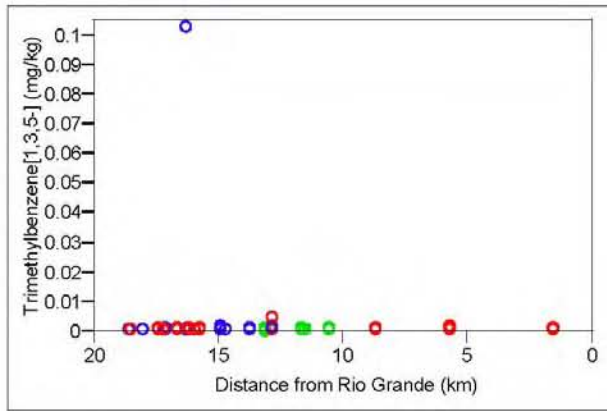
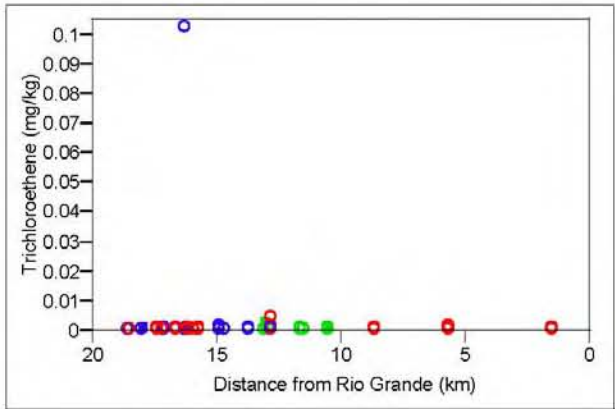
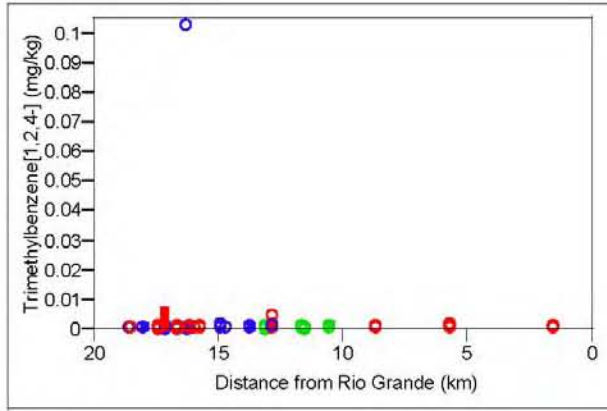
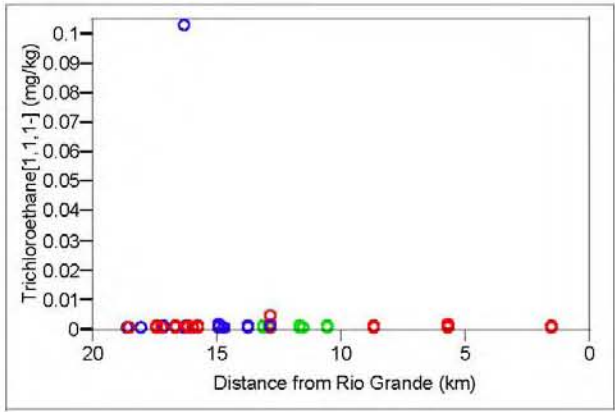

Figure D-1.1-2 (continued)

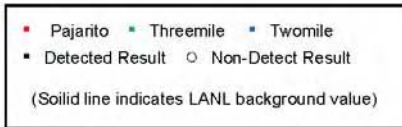
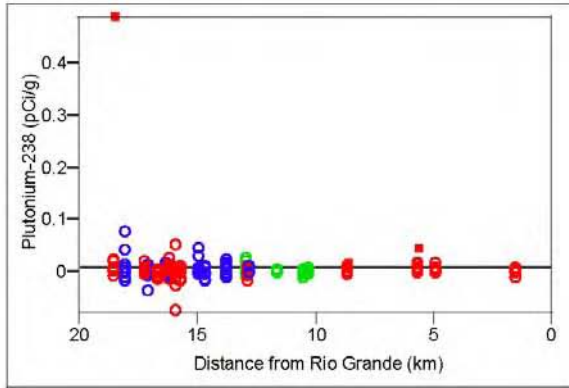
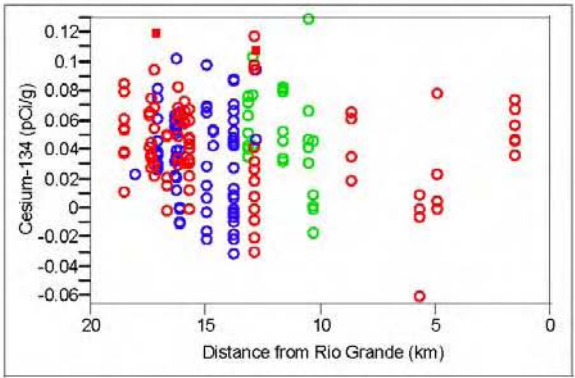
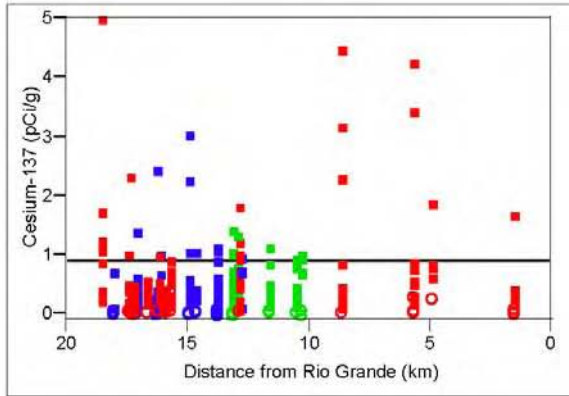
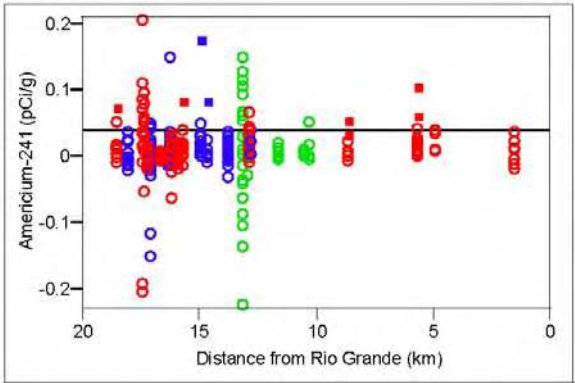

Figure D-1.1-3 Plots of sample results versus distance from the Rio Grande for all radionuclide COPCs identified in sediment in the Pajarito watershed

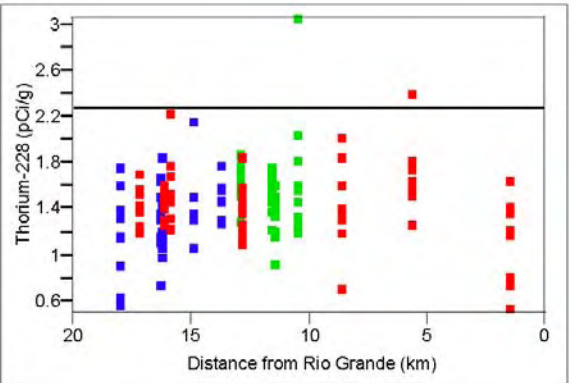
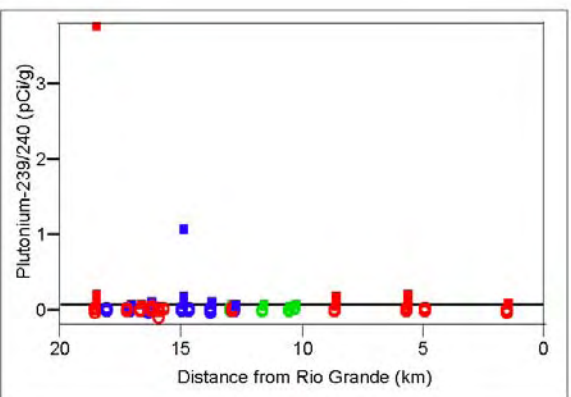
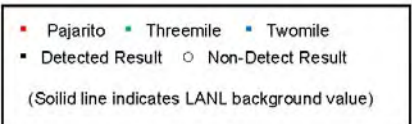
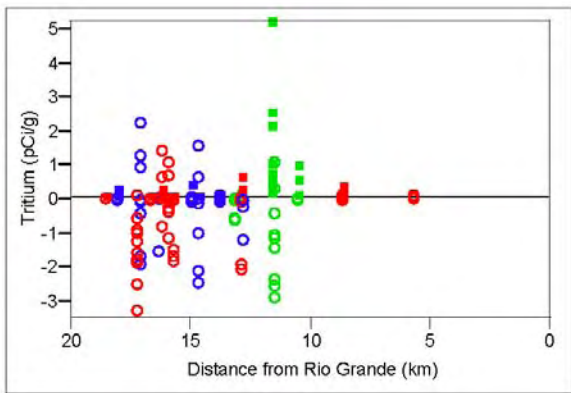
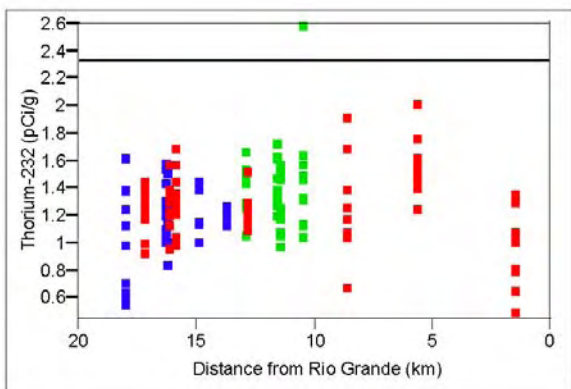

Figure D-1.1-3 (continued)

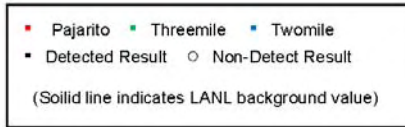
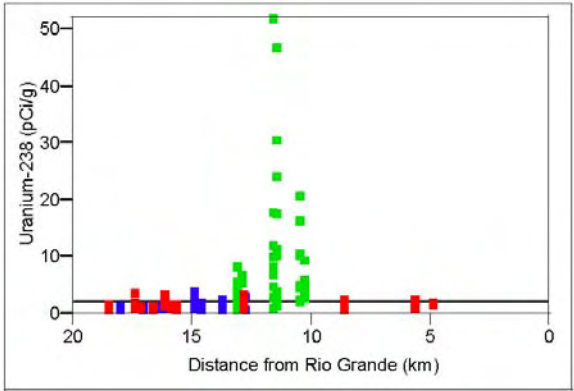
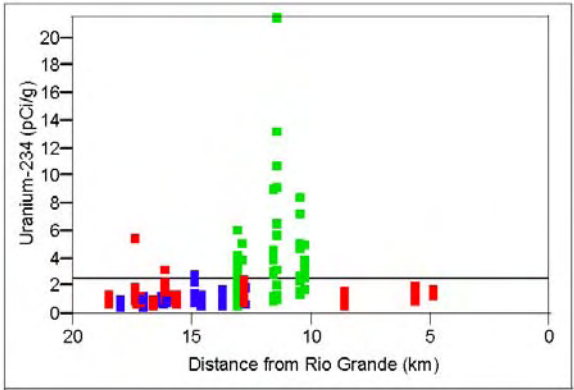
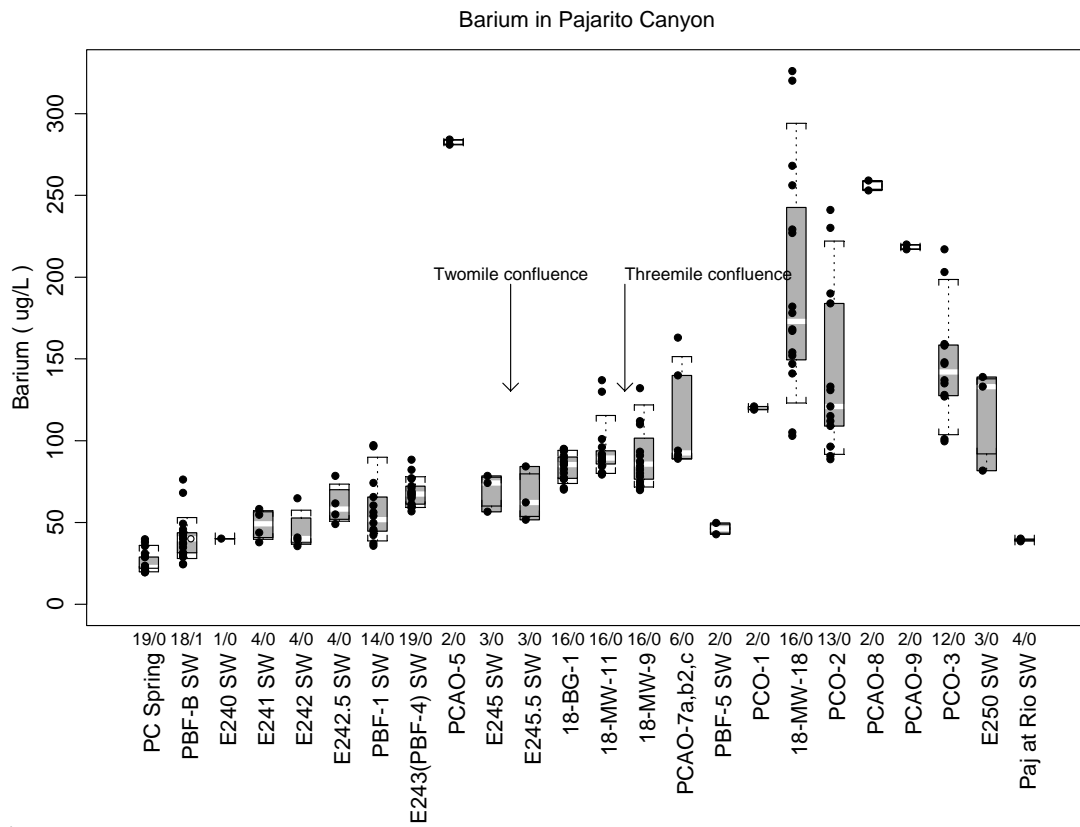
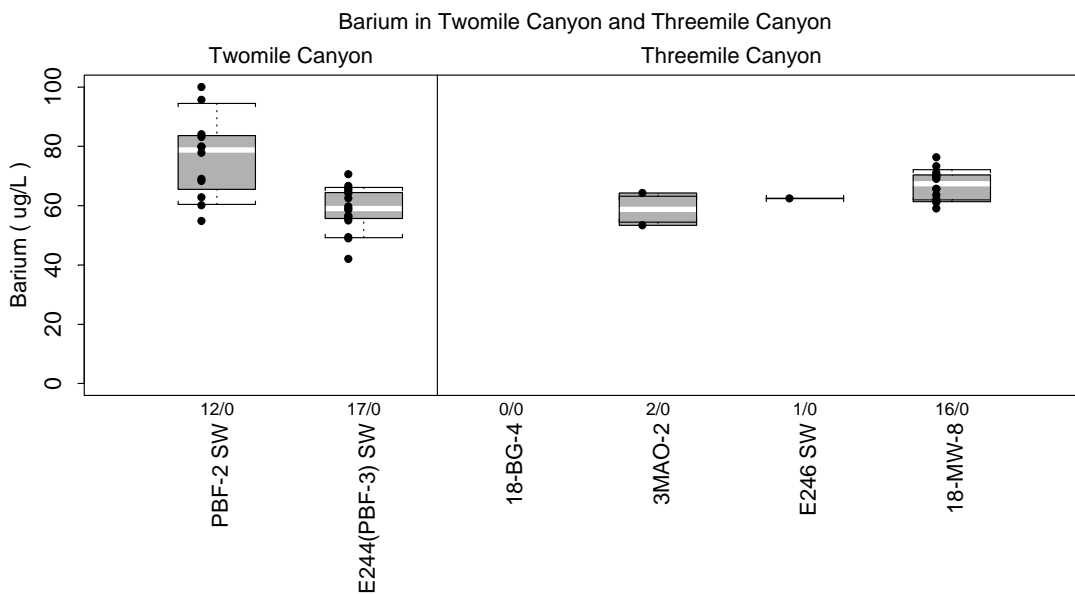

Figure D-1.1-3 (continued)



(a)



(b)

Figure D-2.1-1 Box plots showing the spatial distribution of barium ($\mu\text{g/L}$) at surface water and alluvial groundwater locations in both filtered and nonfiltered samples (a) in Pajarito Canyon and (b) in Twomile and in Threemile Canyon

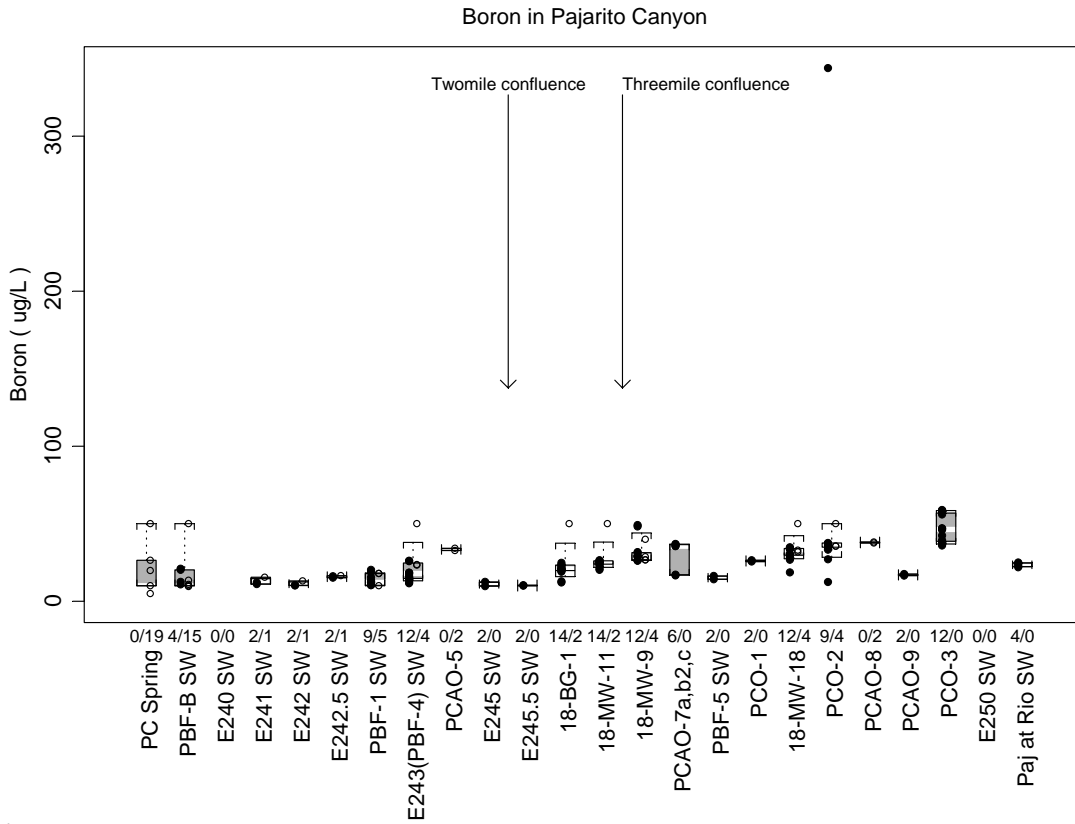

(a)

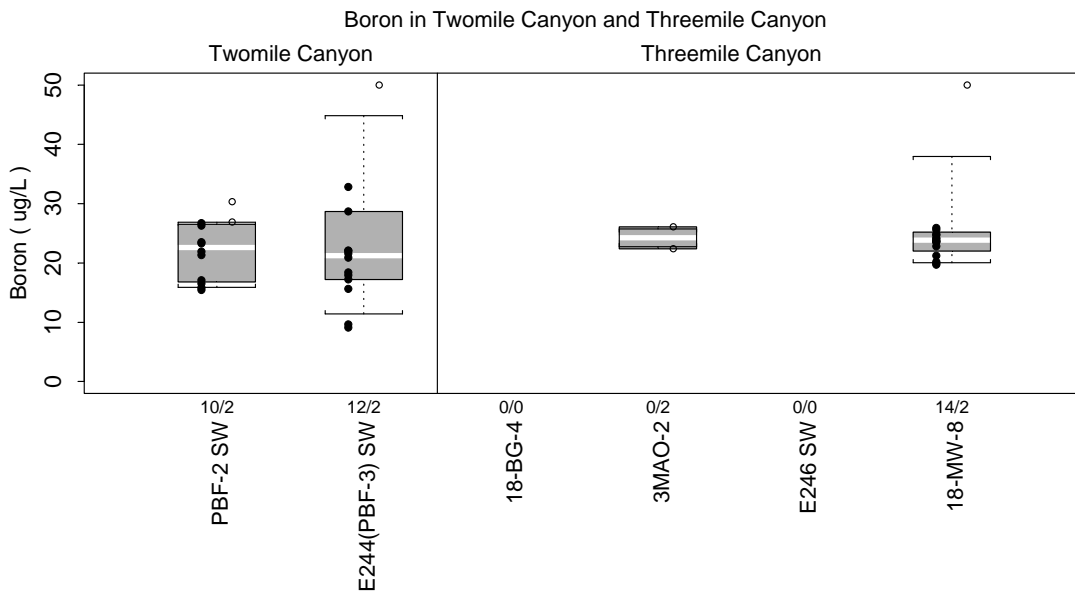

(b)

Figure D-2.1-2 Box plots showing the spatial distribution of boron ($\mu\text{g/L}$) at surface water and alluvial groundwater locations in both filtered and nonfiltered samples (a) in Pajarito Canyon and (b) in Twomile and in Threemile Canyon

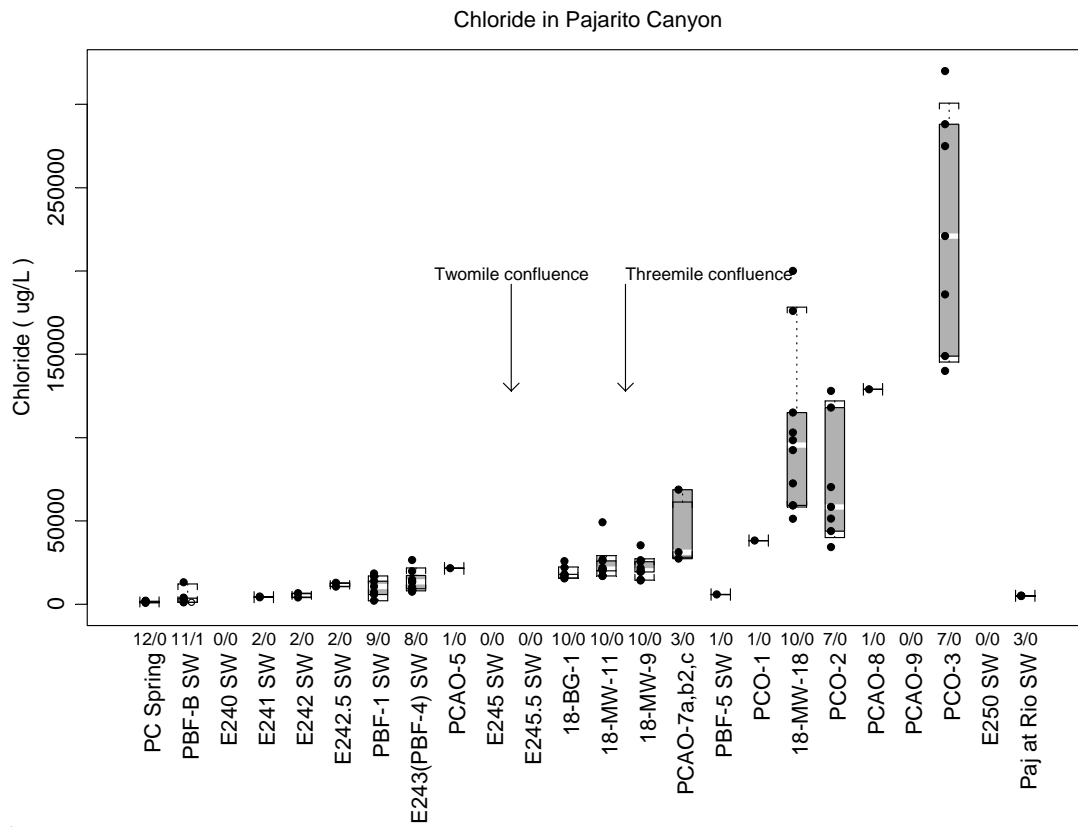

(a)

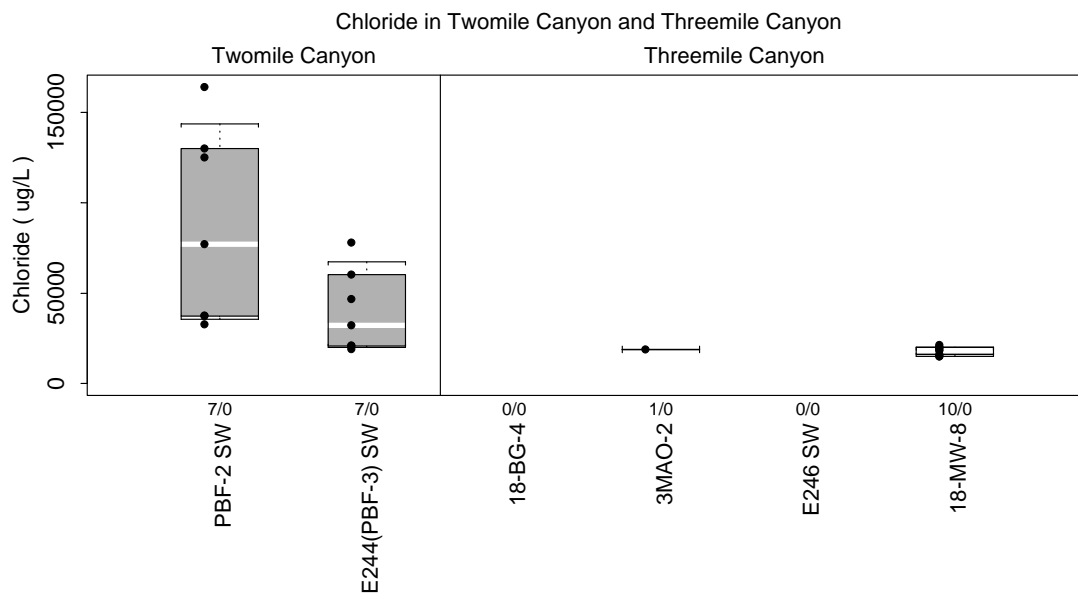

(b)

Figure D-2.1-3 Box plots showing the spatial distribution of chloride ($\mu\text{g/L}$) at surface water and alluvial groundwater locations in both filtered and nonfiltered samples (a) in Pajarito Canyon and (b) in Twomile and in Threemile Canyon

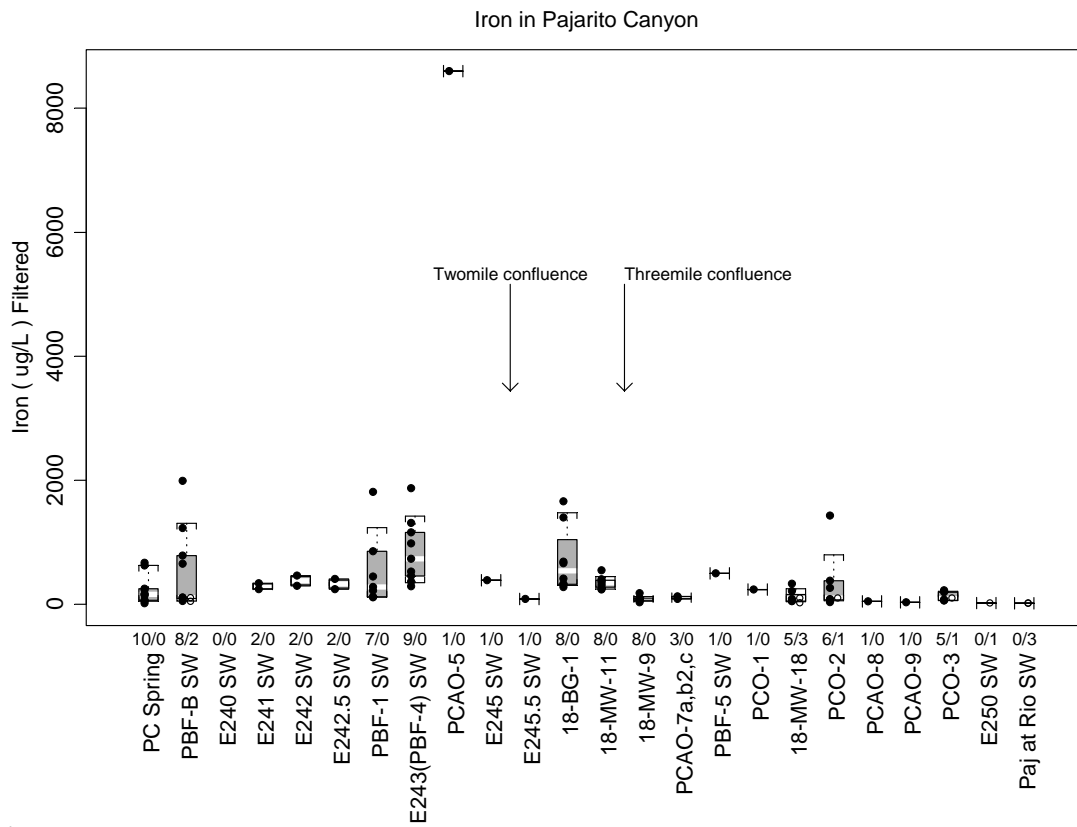

(a)

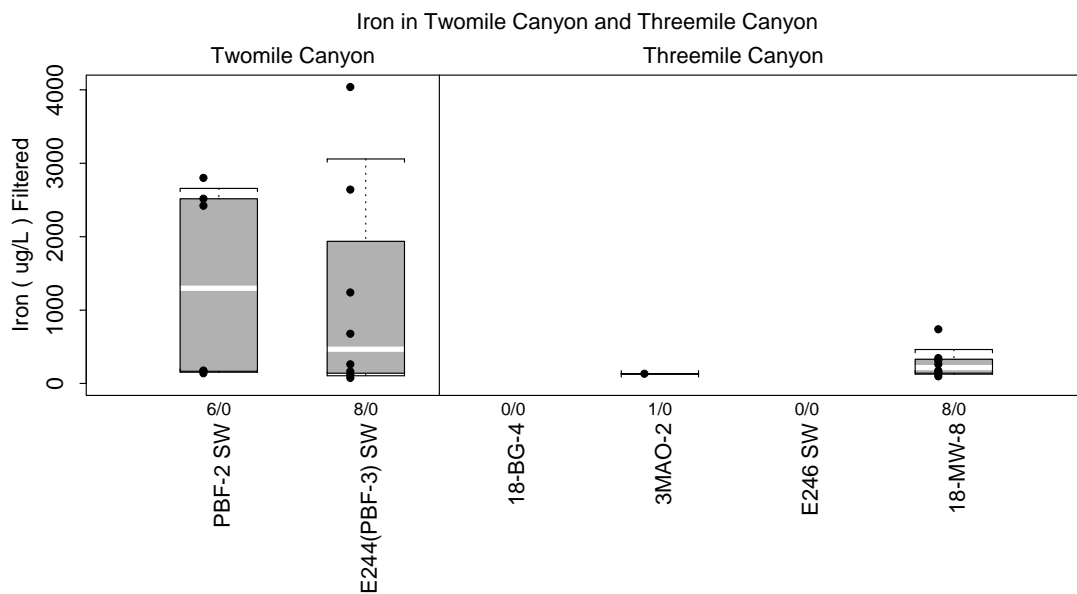

(b)

Figure D-2.1-4 Box plots showing the spatial distribution of iron ($\mu\text{g/L}$) at surface water and alluvial groundwater locations in filtered samples (a) in Pajarito Canyon and (b) in Twomile and in Threemile Canyon

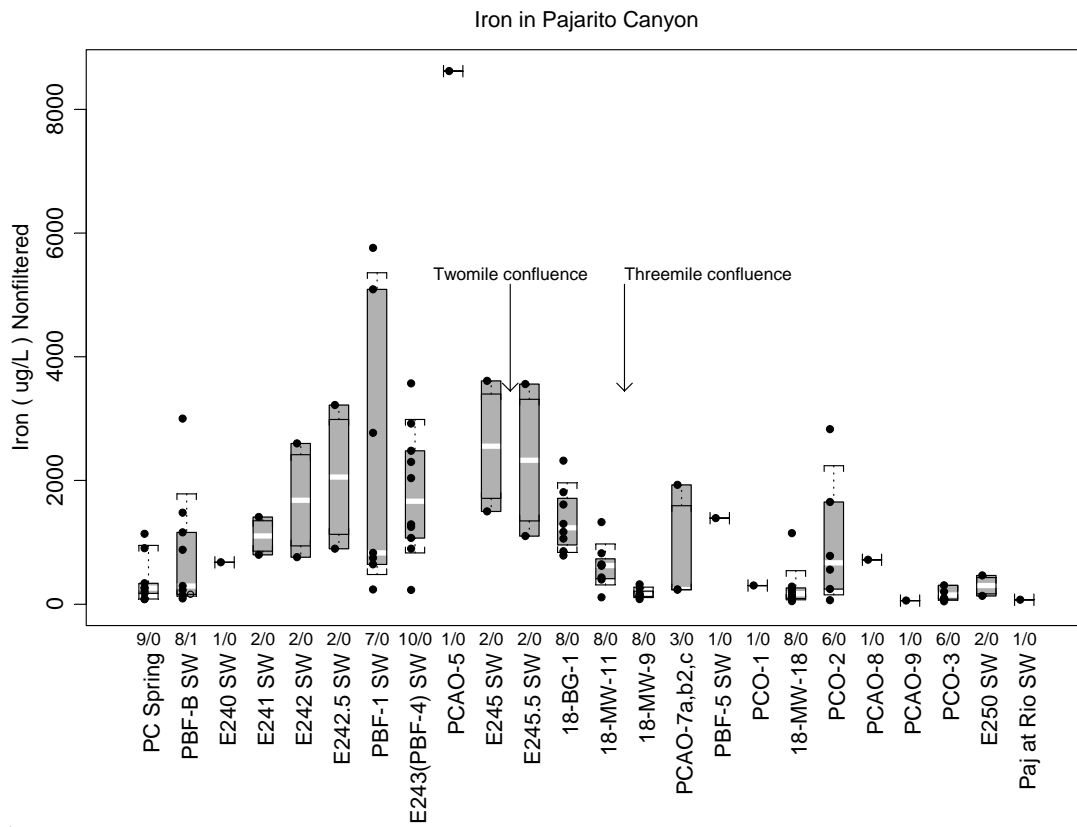

(a)

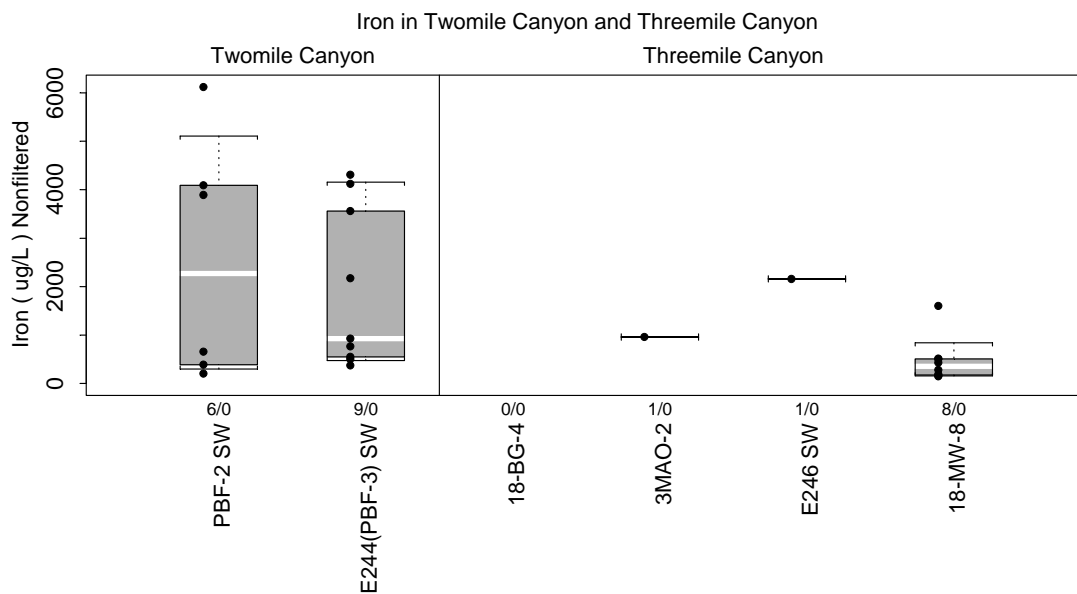

(b)

Figure D-2.1-5 Box plots showing the spatial distribution of iron ($\mu\text{g/L}$) at surface water and alluvial groundwater locations in nonfiltered samples (a) in Pajarito Canyon and (b) in Twomile and in Threemile Canyon

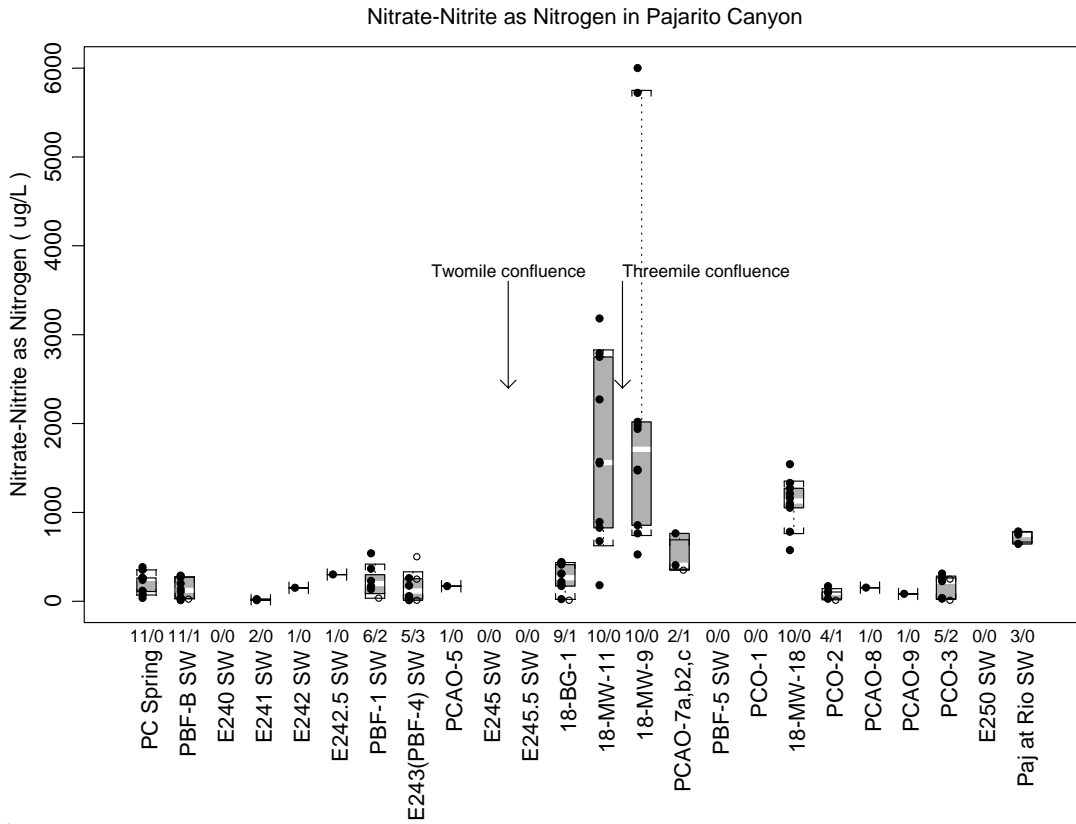

(a)

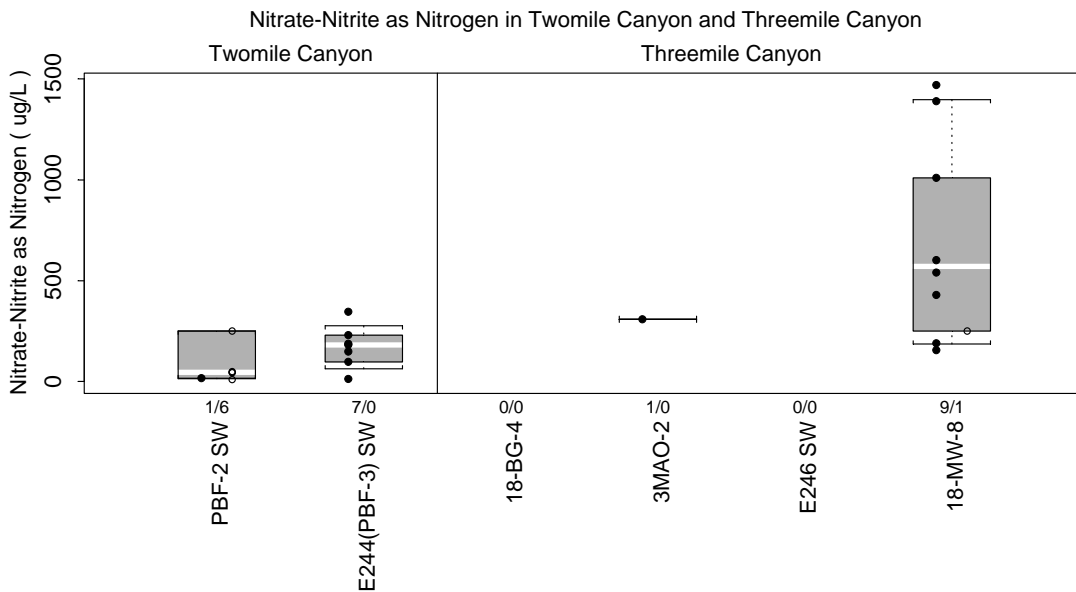

(b)

Figure D-2.1-6 Box plots showing the spatial distribution of nitrate-nitrite as nitrogen ($\mu\text{g/L}$) at surface water and alluvial groundwater locations in both filtered and nonfiltered samples (a) in Pajarito Canyon and (b) in Twomile and in Threemile Canyon

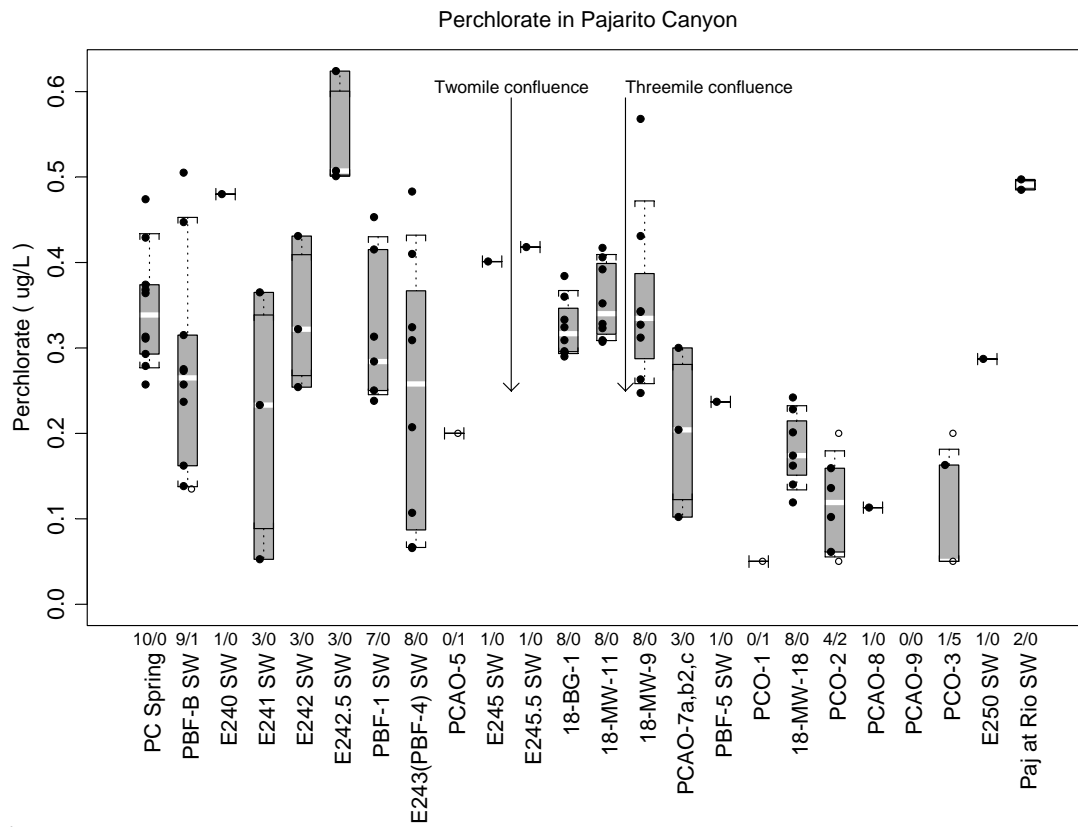

(a)

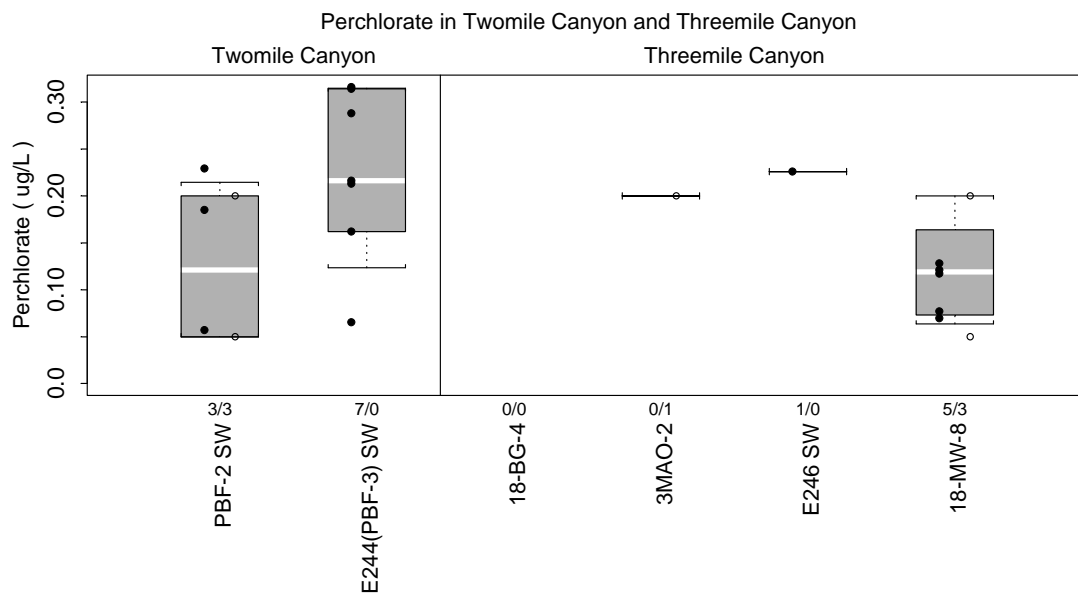

(b)

Figure D-2.1-7 Box plots showing the spatial distribution of perchlorate ($\mu\text{g/L}$) at surface water and alluvial groundwater locations in both filtered and nonfiltered samples (a) in Pajarito Canyon and (b) in Twomile and in Threemile Canyon

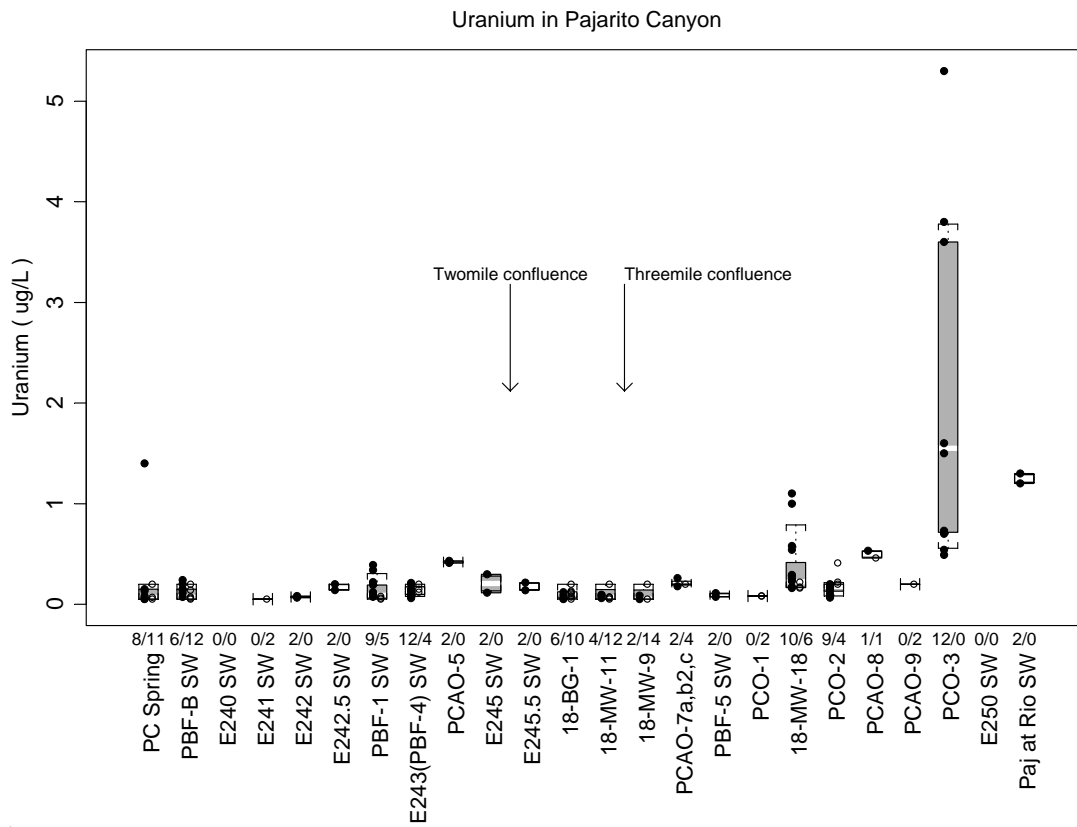

(a)

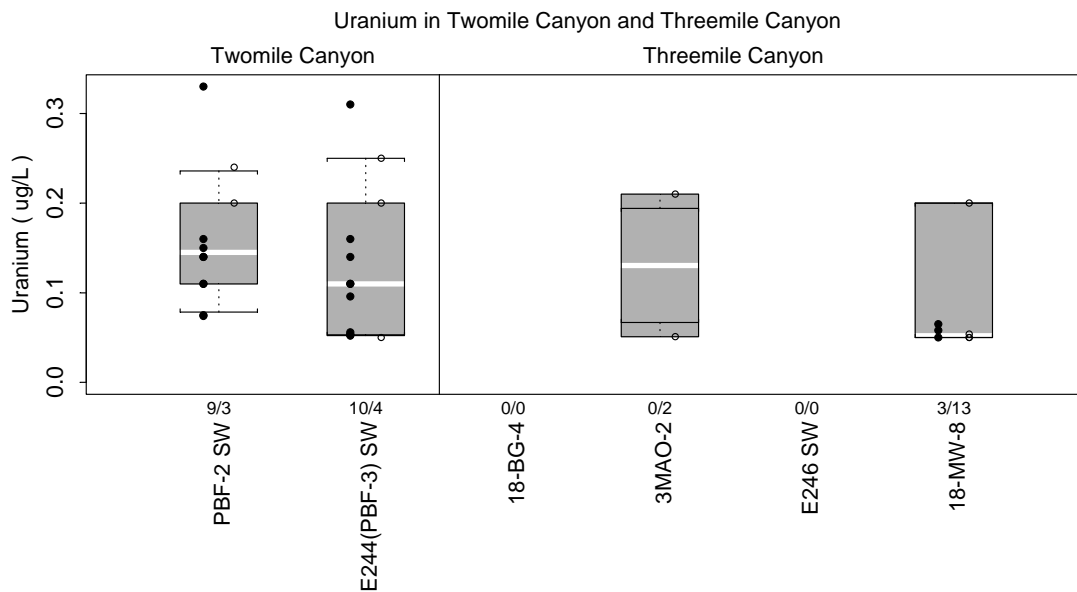

(b)

Figure D-2.1-8 Box plots showing the spatial distribution of uranium ($\mu\text{g/L}$) at surface water and alluvial groundwater locations in both filtered and nonfiltered samples (a) in Pajarito Canyon and (b) in Twomile and in Threemile Canyon

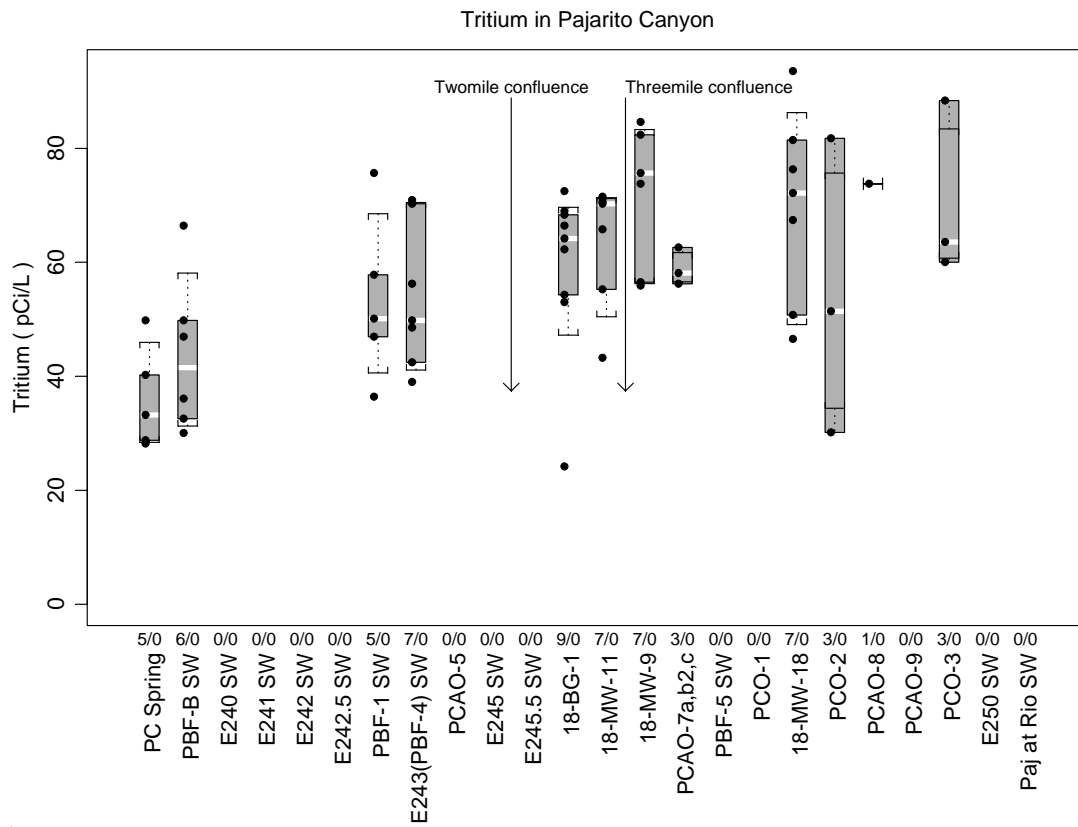

(a)

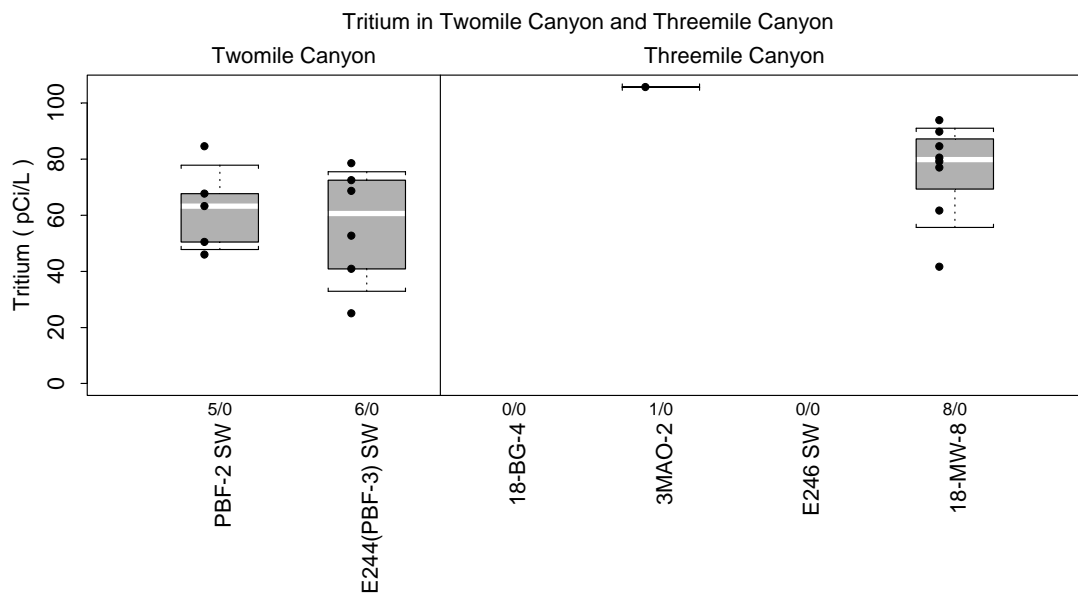

(b)

Figure D-2.1-9 Box plots showing the spatial distribution of tritium (pCi/L) at surface water and alluvial groundwater locations in both filtered and nonfiltered samples (a) in Pajarito Canyon and (b) in Twomile and in Threemile Canyon

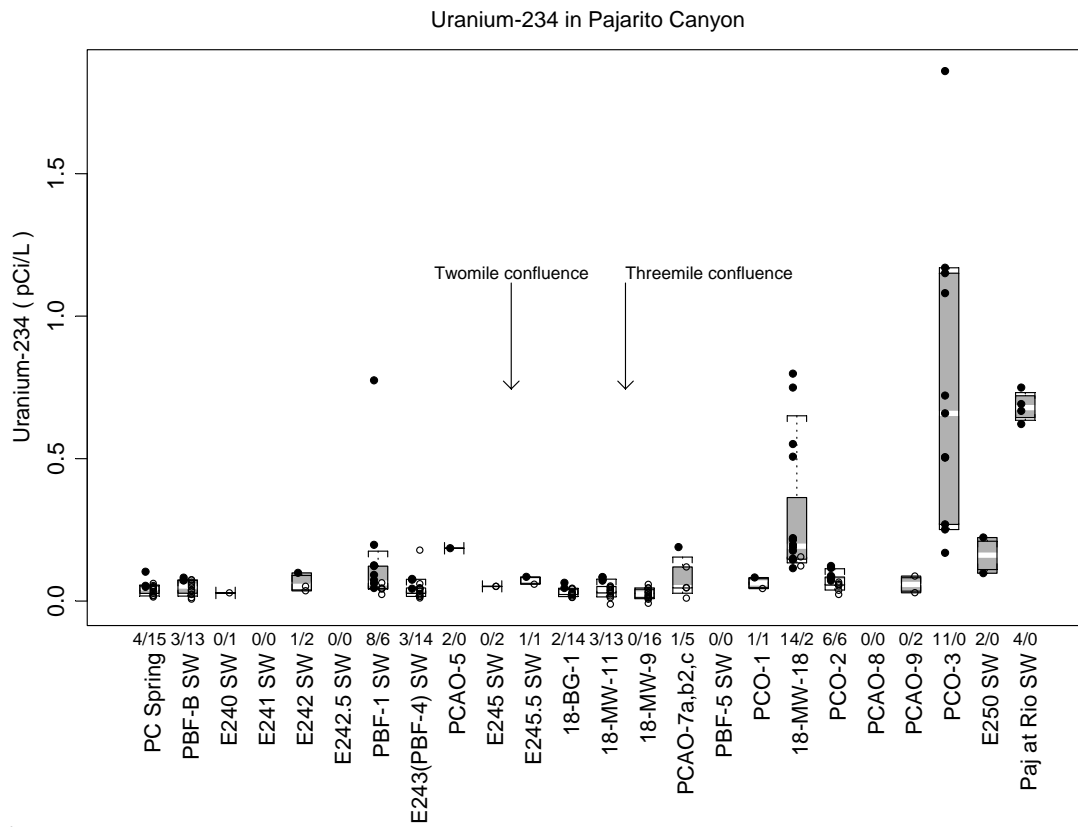

(a)

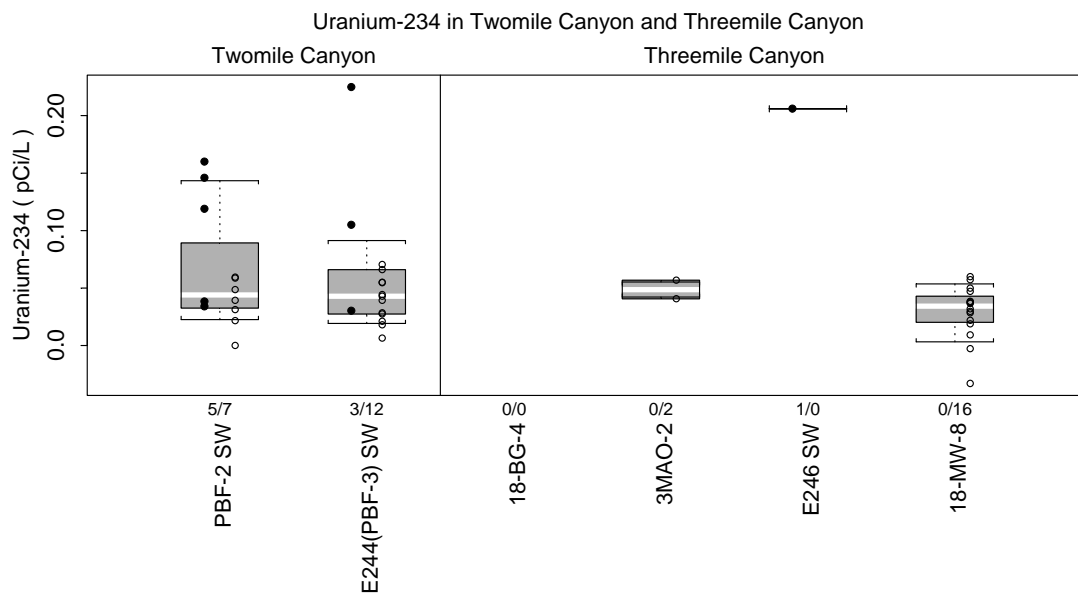

(b)

Figure D-2.1-10 Box plots showing the spatial distribution of uranium-234 (pCi/L) at surface water and alluvial groundwater locations in both filtered and nonfiltered samples (a) in Pajarito Canyon and (b) in Twomile and in Threemile Canyon

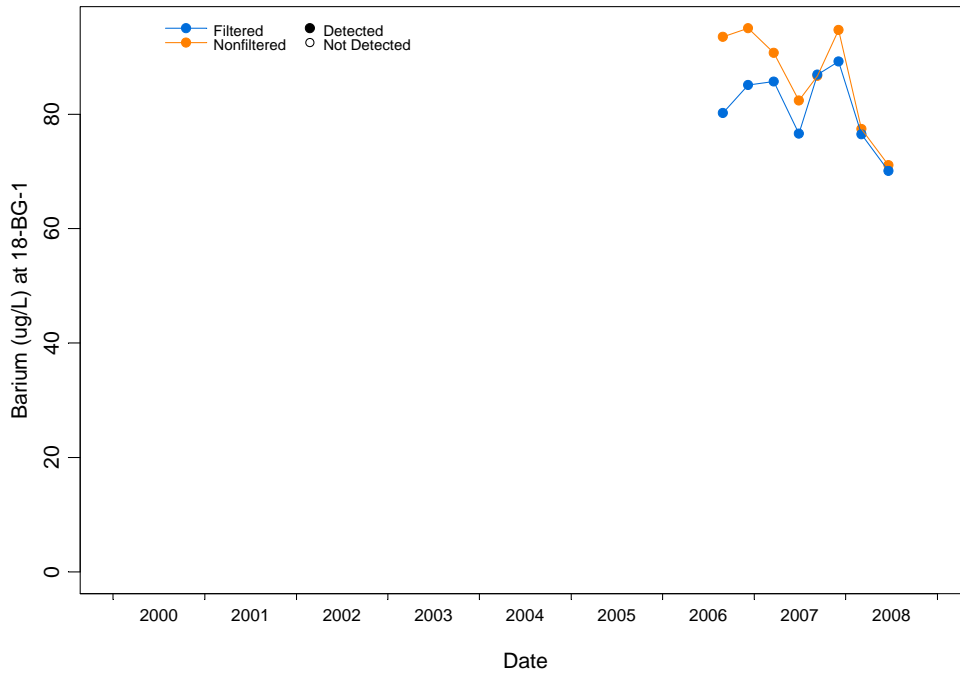

Figure D-2.2-1 Concentrations over time at 18-BG-1 for barium

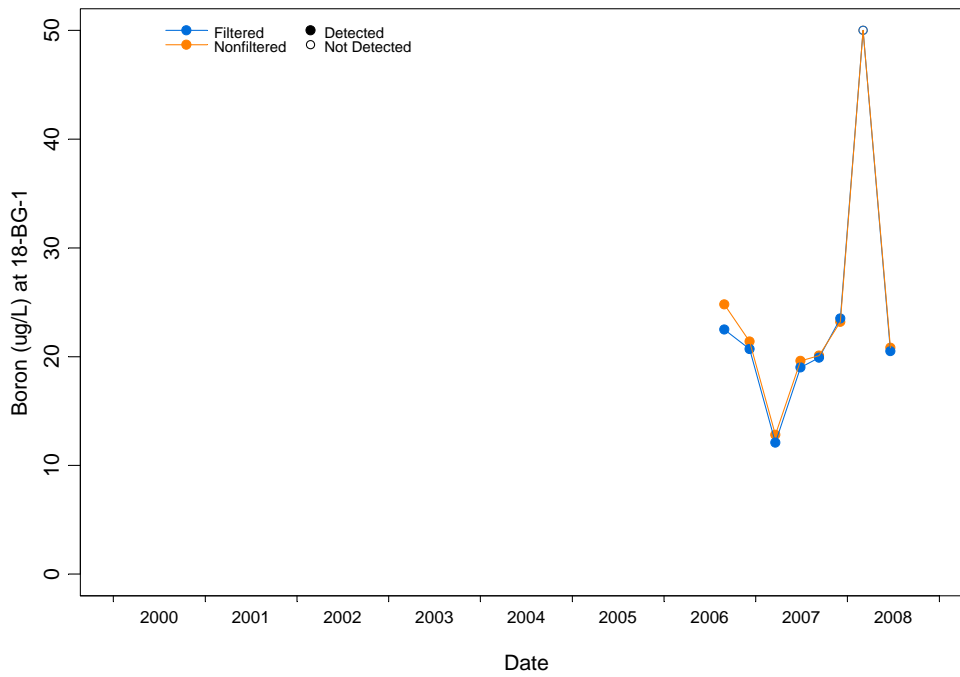

Figure D-2.2-2 Concentrations over time at 18-BG-1 for boron

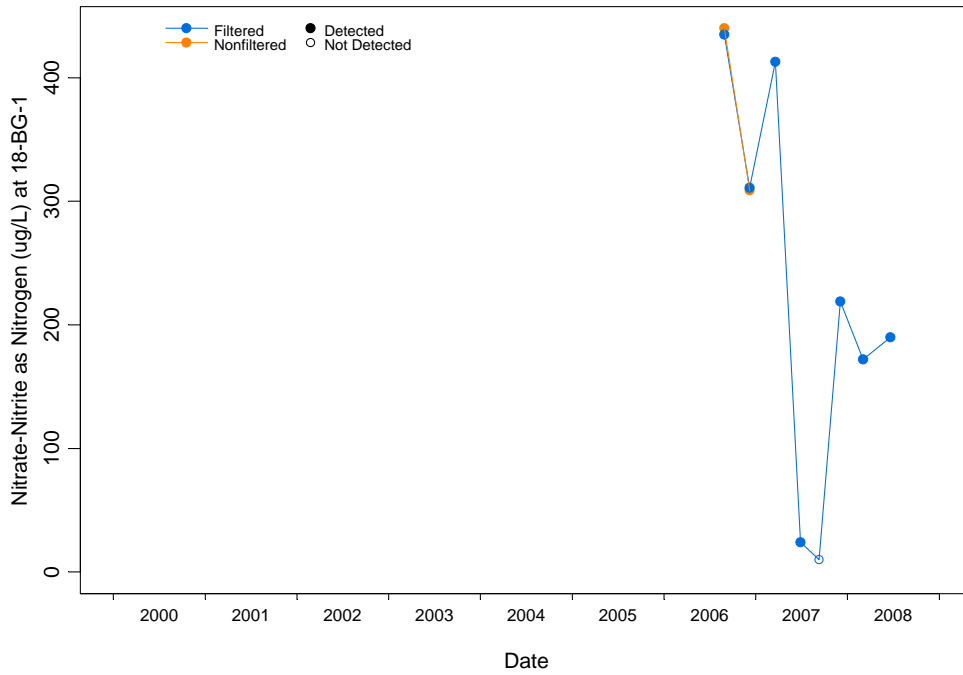

Figure D-2.2-3 Concentrations over time at 18-BG-1 for nitrate-nitrite as nitrogen

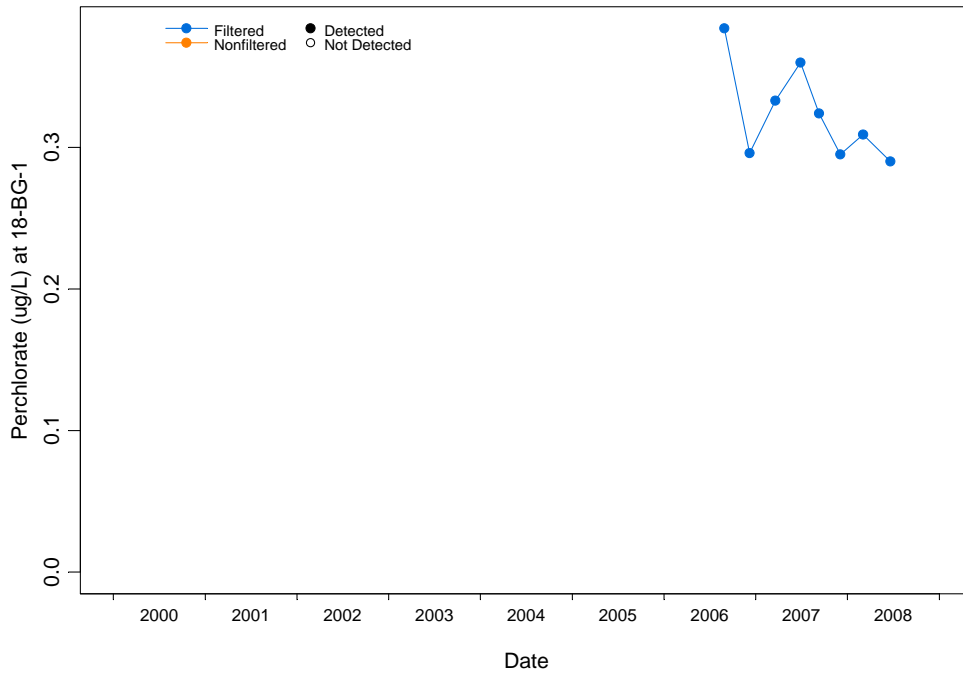

Figure D-2.2-4 Concentrations over time at 18-BG-1 for perchlorate

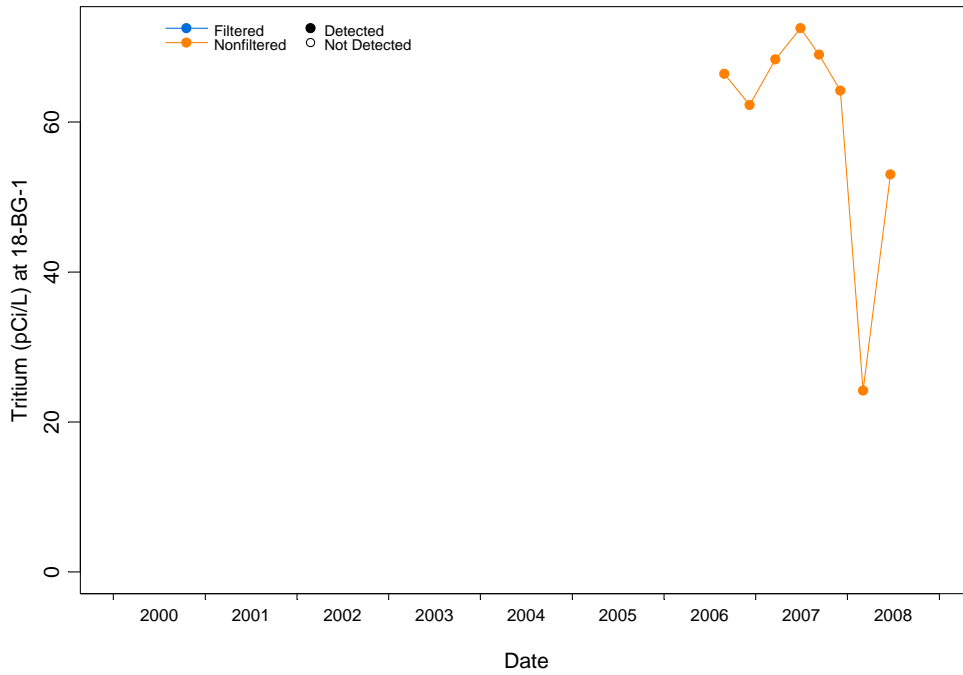

Figure D-2.2-5 Concentrations over time at 18-BG-1 for tritium

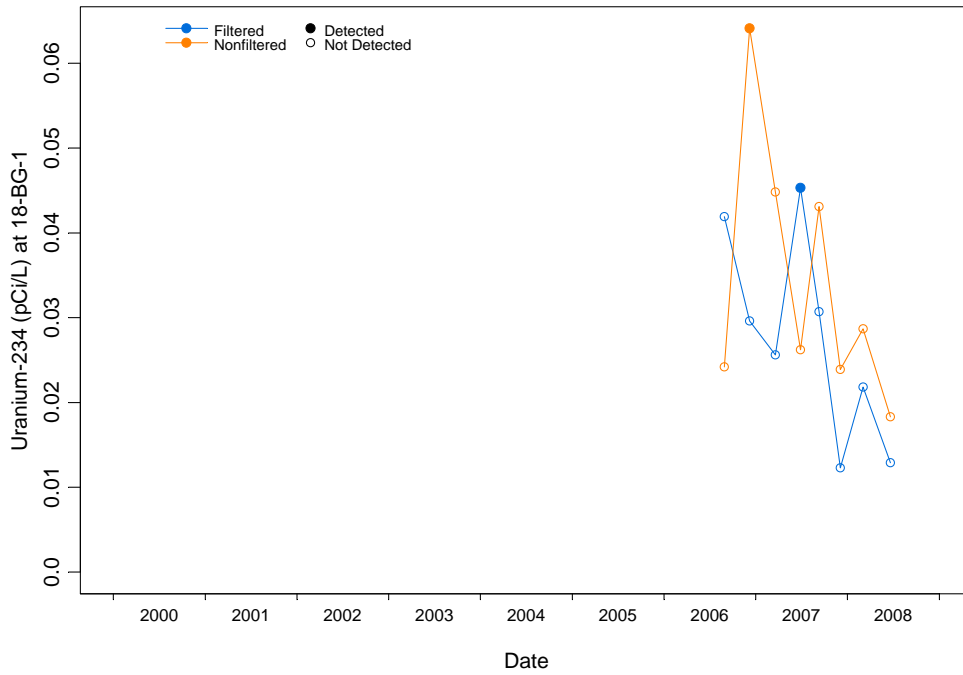

Figure D-2.2-6 Concentrations over time at 18-BG-1 for uranium-234

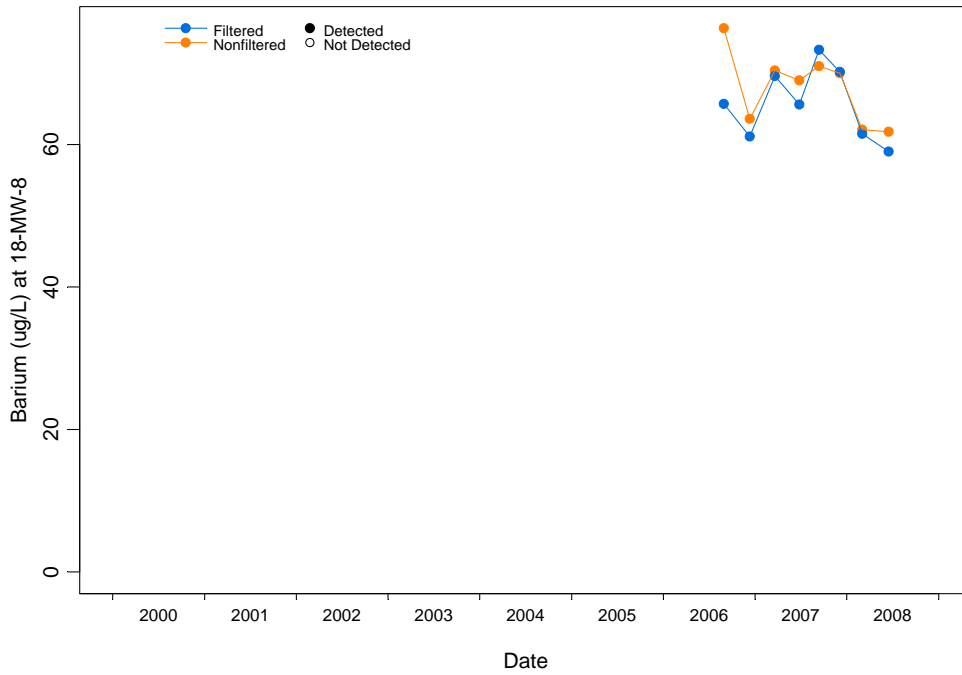

Figure D-2.2-7 Concentrations over time at 18-MW-8 for barium

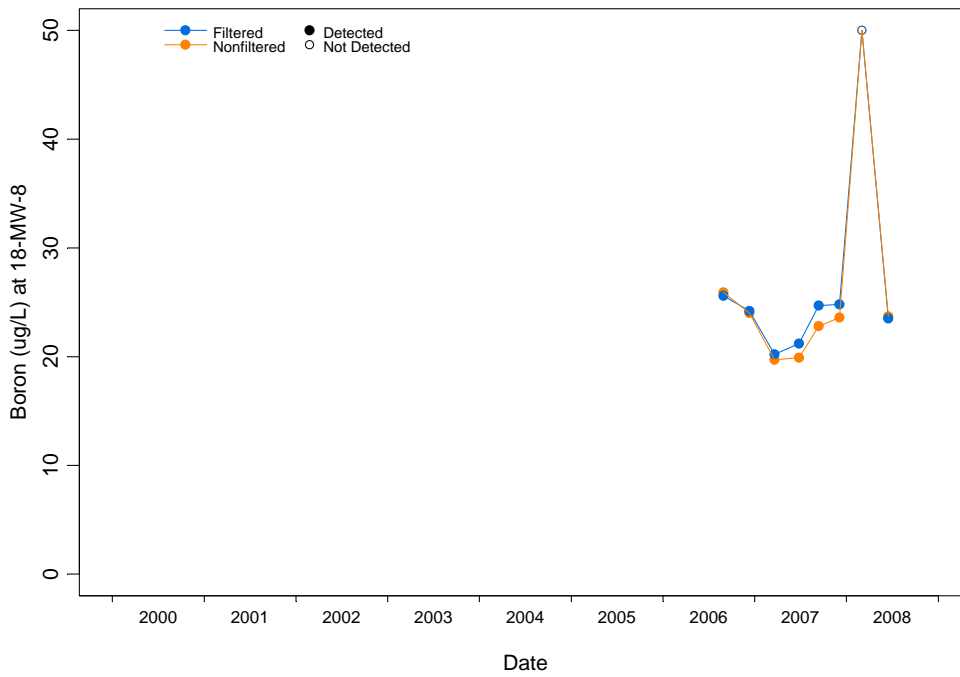

Figure D-2.2-8 Concentrations over time at 18-MW-8 for boron

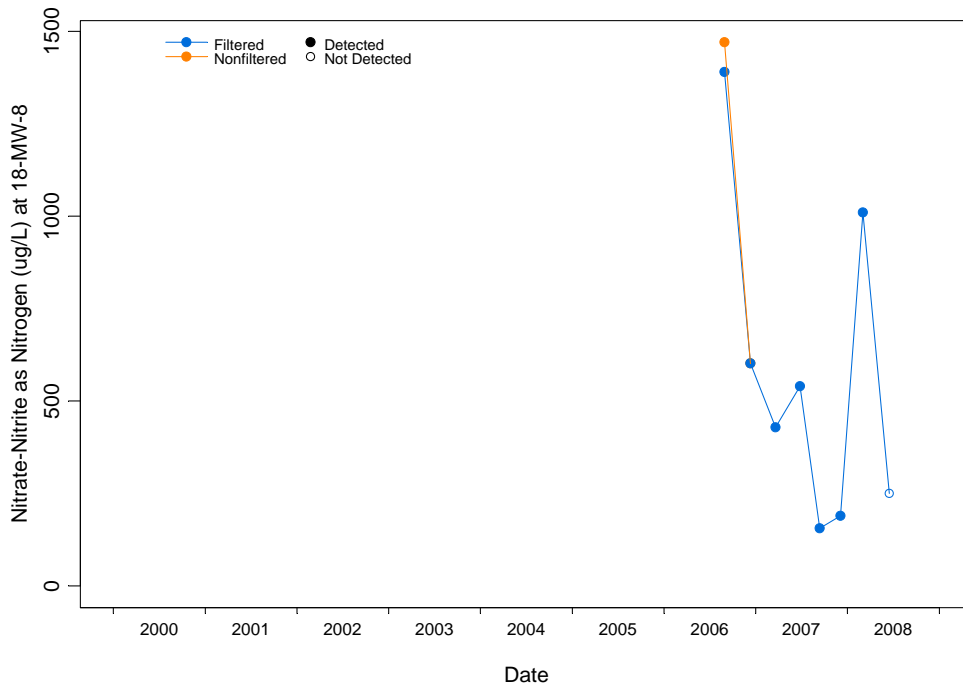

Figure D-2.2-9 Concentrations over time at 18-MW-8 for nitrate-nitrite as nitrogen

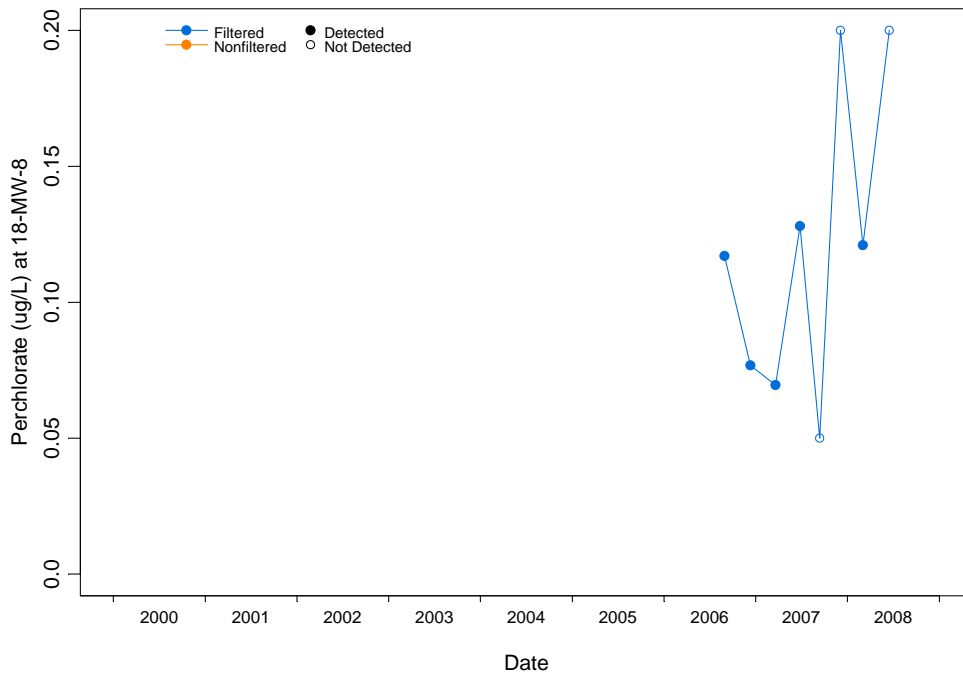

Figure D-2.2-10 Concentrations over time at 18-MW-8 for perchlorate

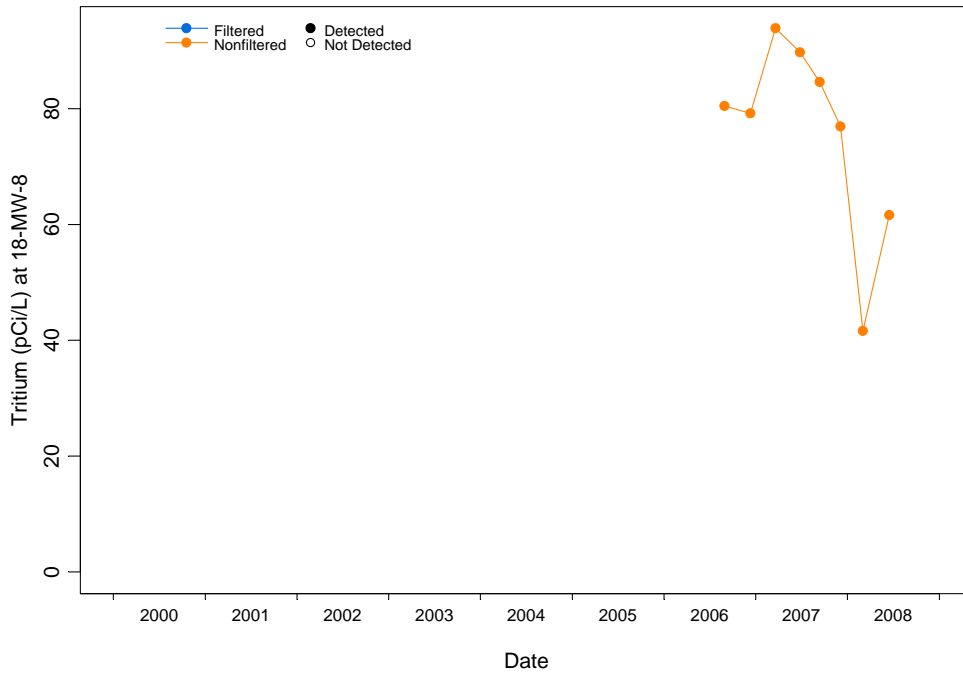

Figure D-2.2-11 Concentrations over time at 18-MW-8 for tritium

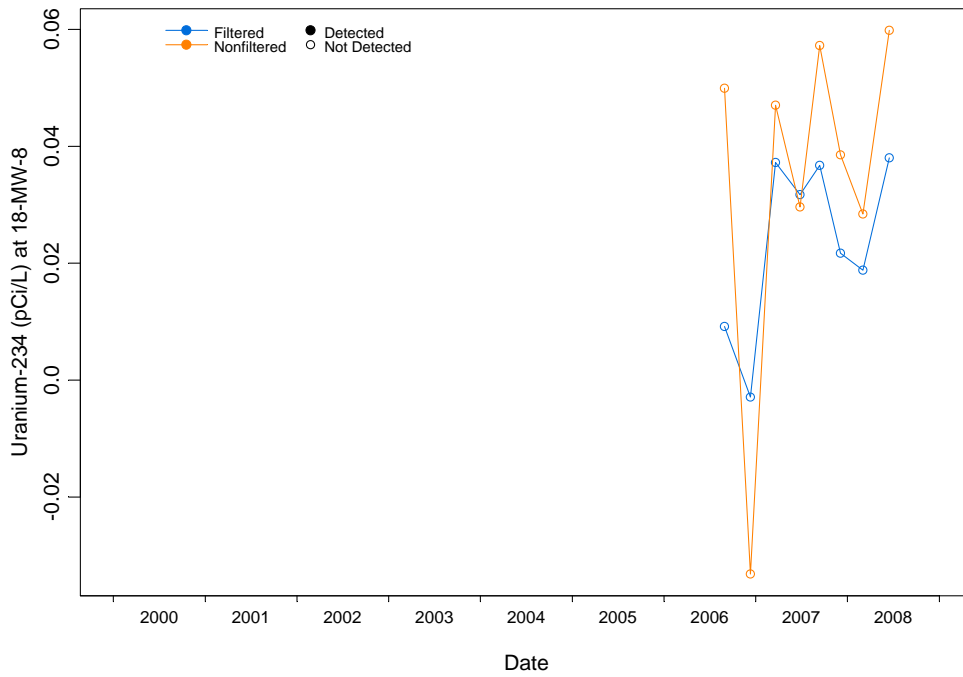

Figure D-2.2-12 Concentrations over time at 18-MW-8 for uranium-234

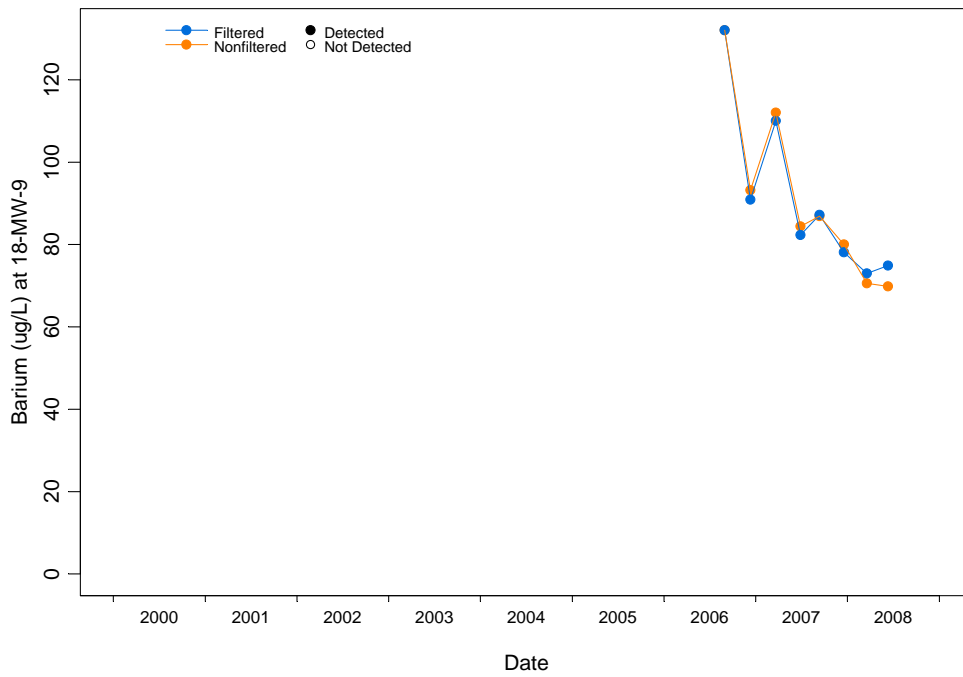

Figure D-2.2-13 Concentrations over time at 18-MW-9 for barium

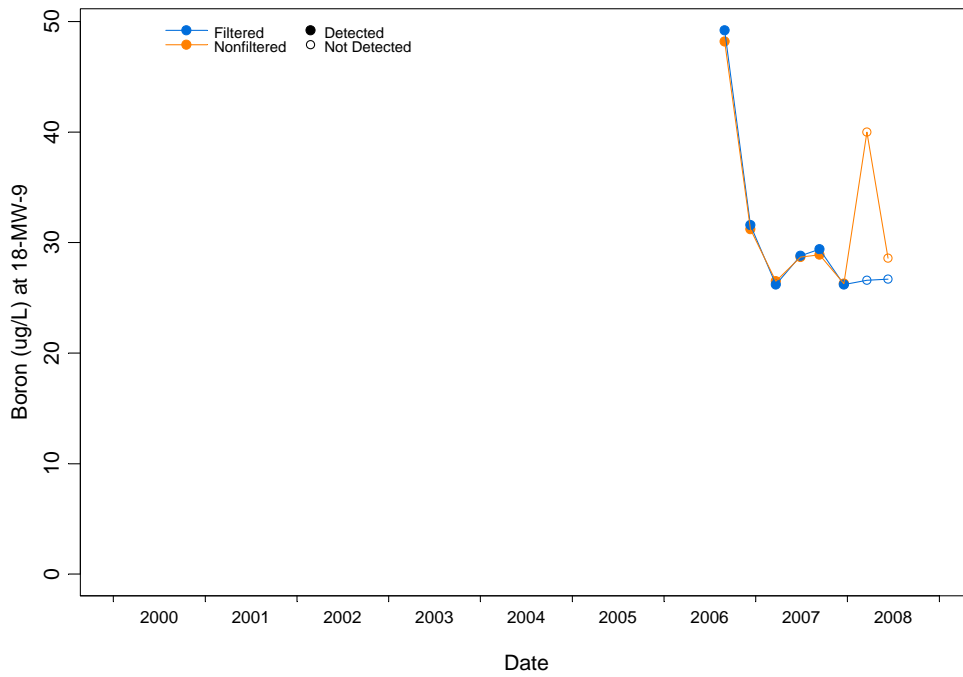

Figure D-2.2-14 Concentrations over time at 18-MW-9 for boron

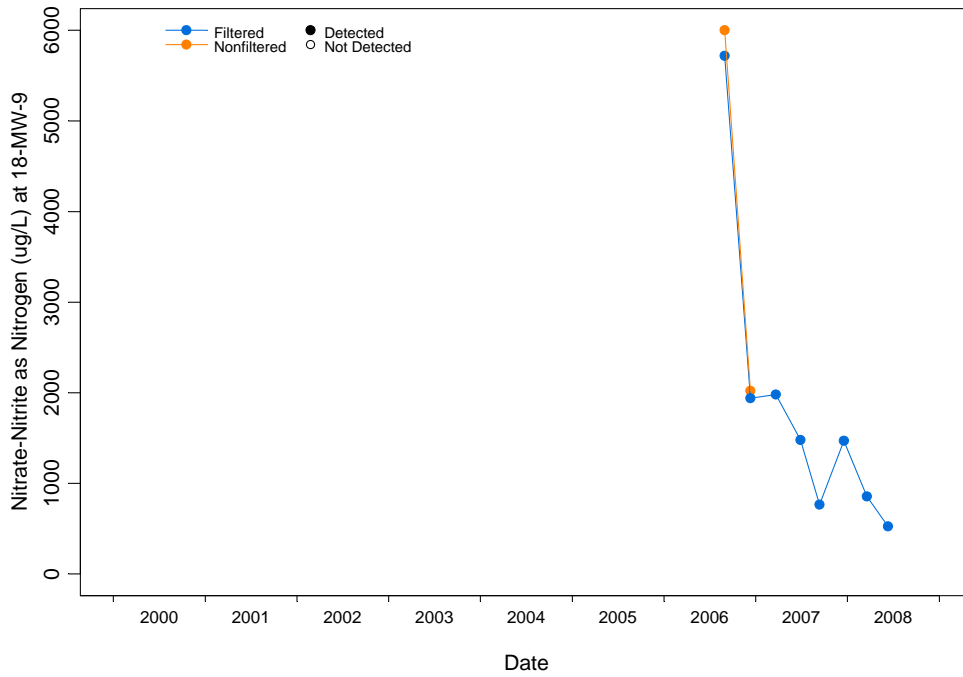

Figure D-2.2-15 Concentrations over time at 18-MW-9 for nitrate-nitrite as nitrogen

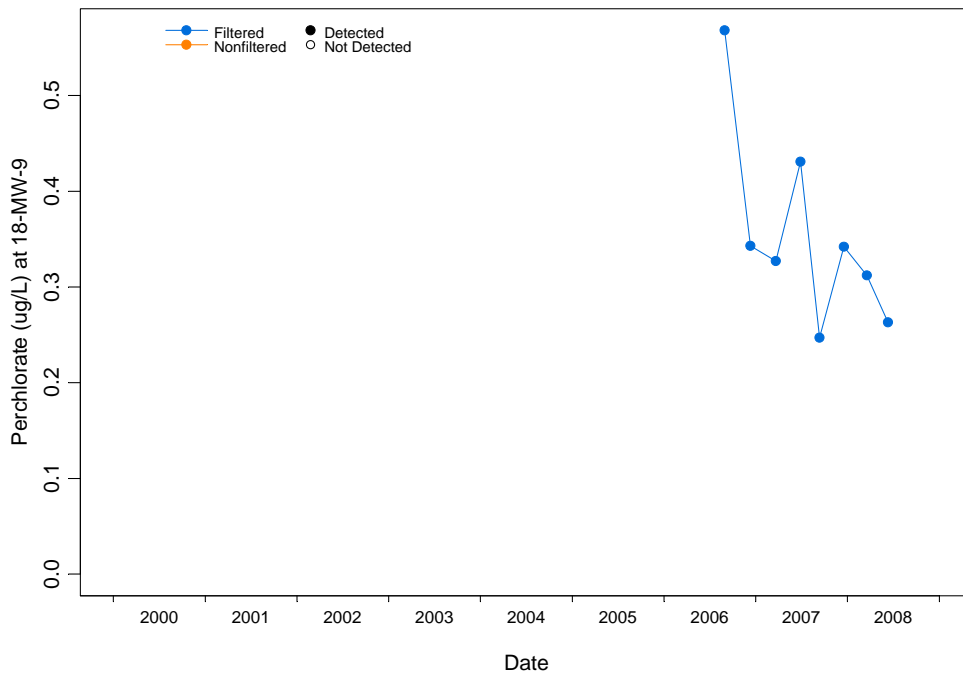

Figure D-2.2-16 Concentrations over time at 18-MW-9 for perchlorate

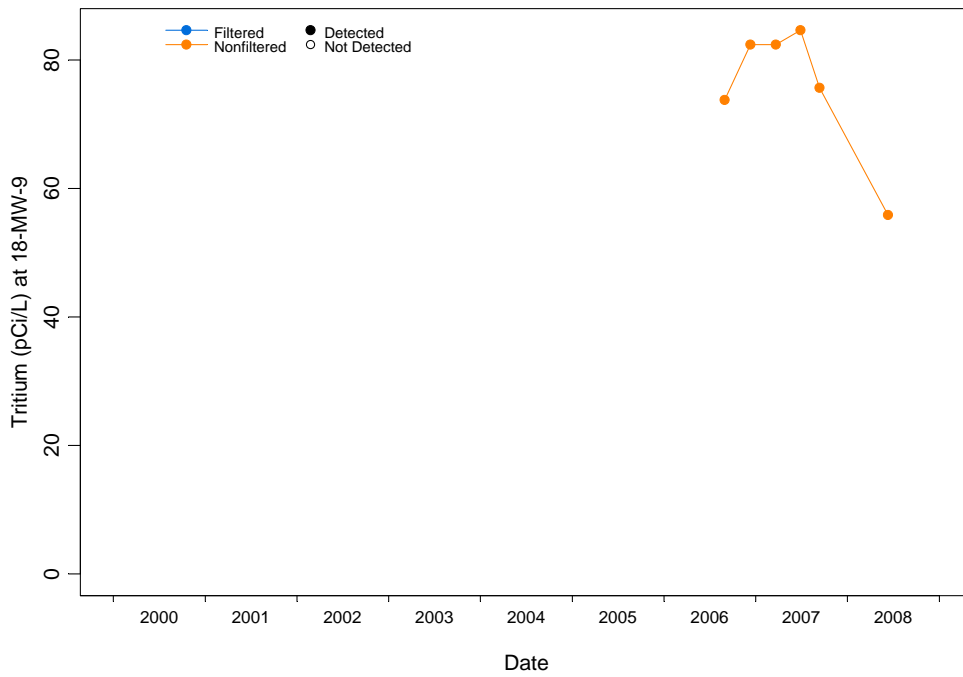

Figure D-2.2-17 Concentrations over time at 18-MW-9 for tritium

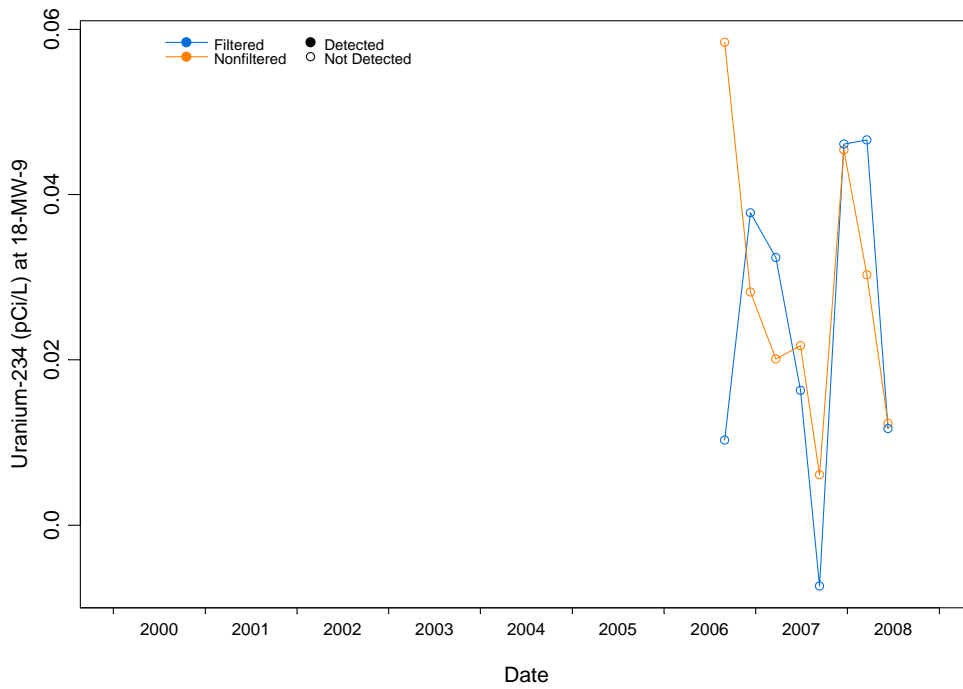

Figure D-2.2-18 Concentrations over time at 18-MW-9 for uranium-234

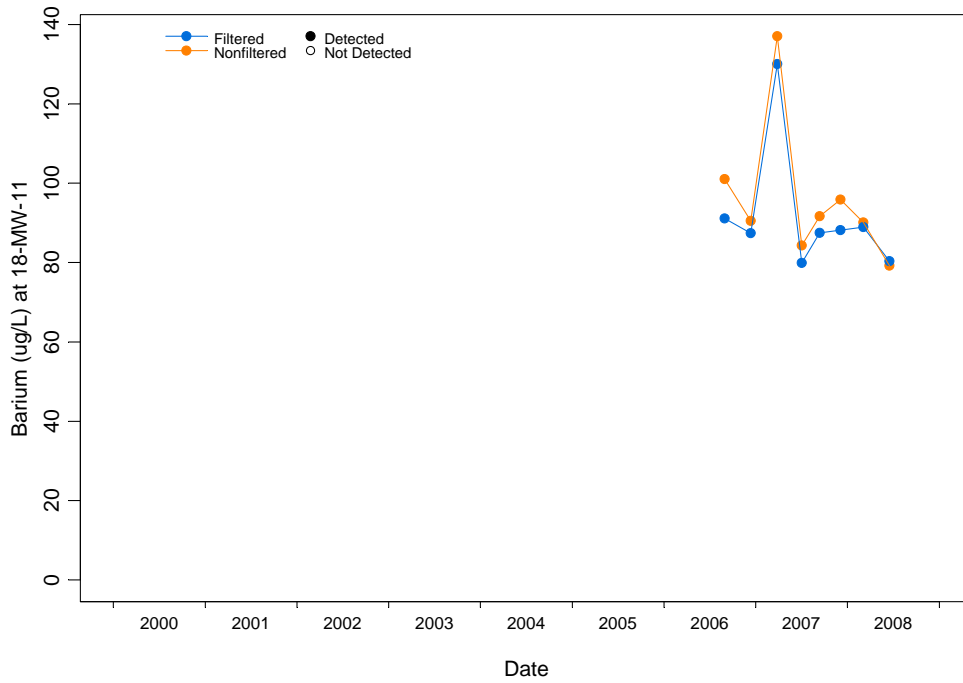

Figure D-2.2-19 Concentrations over time at 18-MW-11 for barium

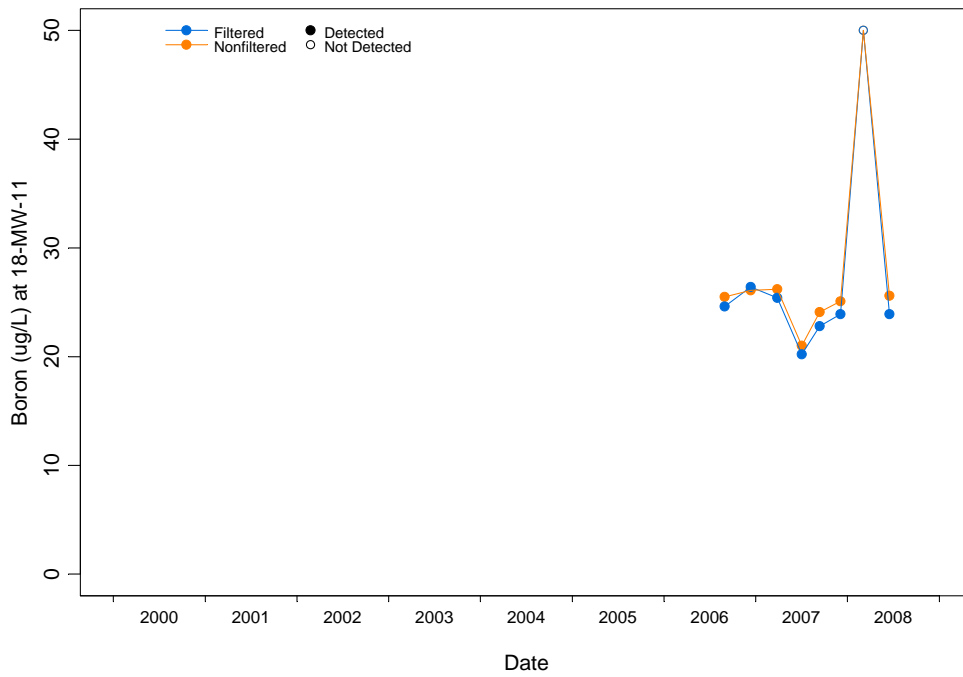

Figure D-2.2-20 Concentrations over time at 18-MW-11 for boron

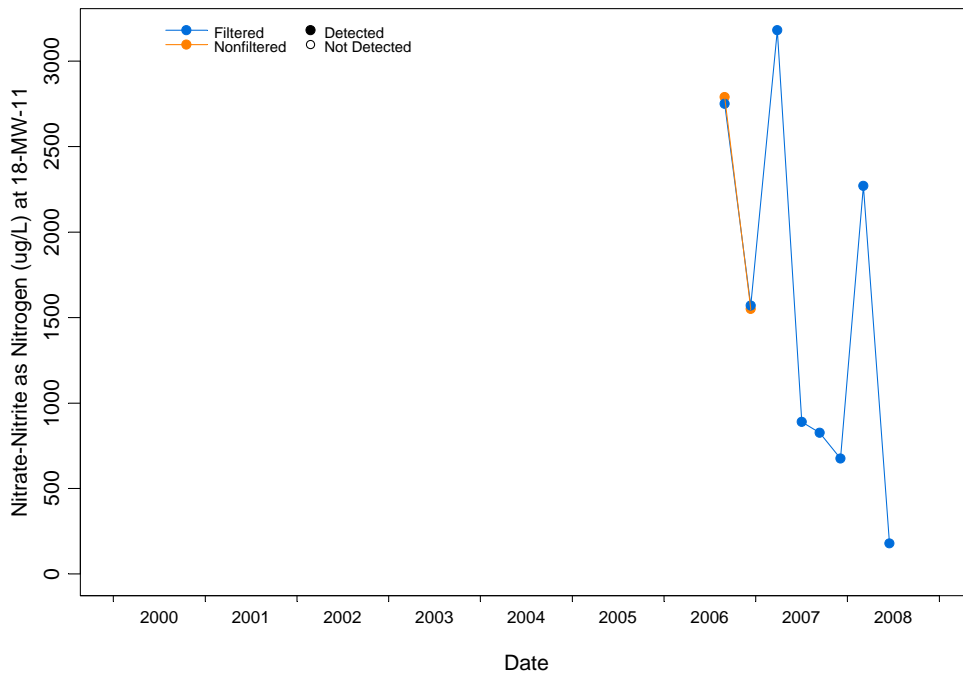

Figure D-2.2-21 Concentrations over time at 18-MW-11 for nitrate-nitrite as nitrogen

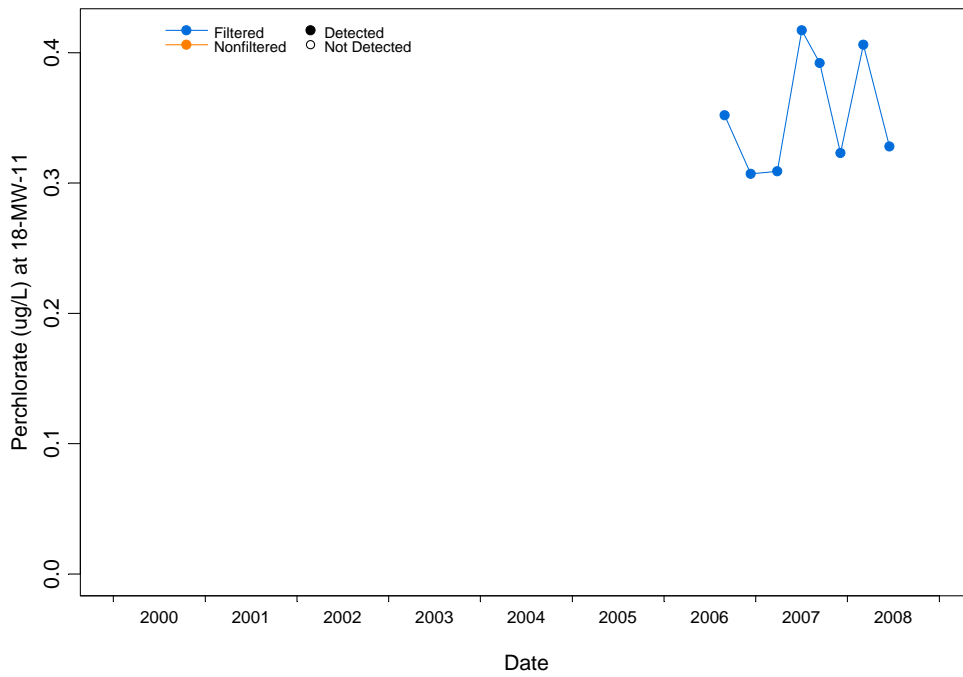

Figure D-2.2-22 Concentrations over time at 18-MW-11 for perchlorate

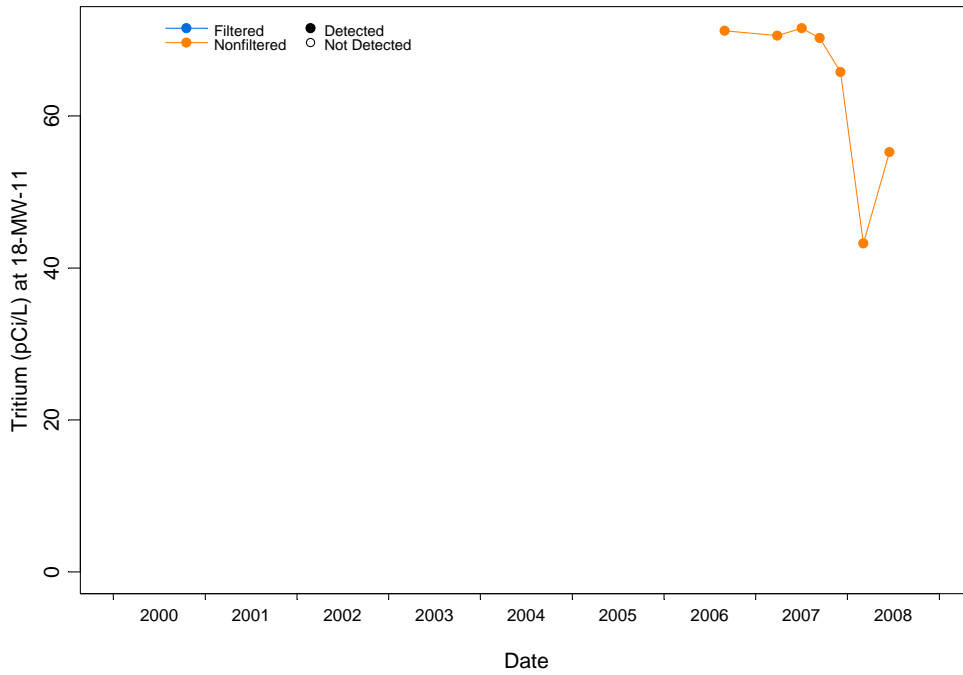

Figure D-2.2-23 Concentrations over time at 18-MW-11 for tritium

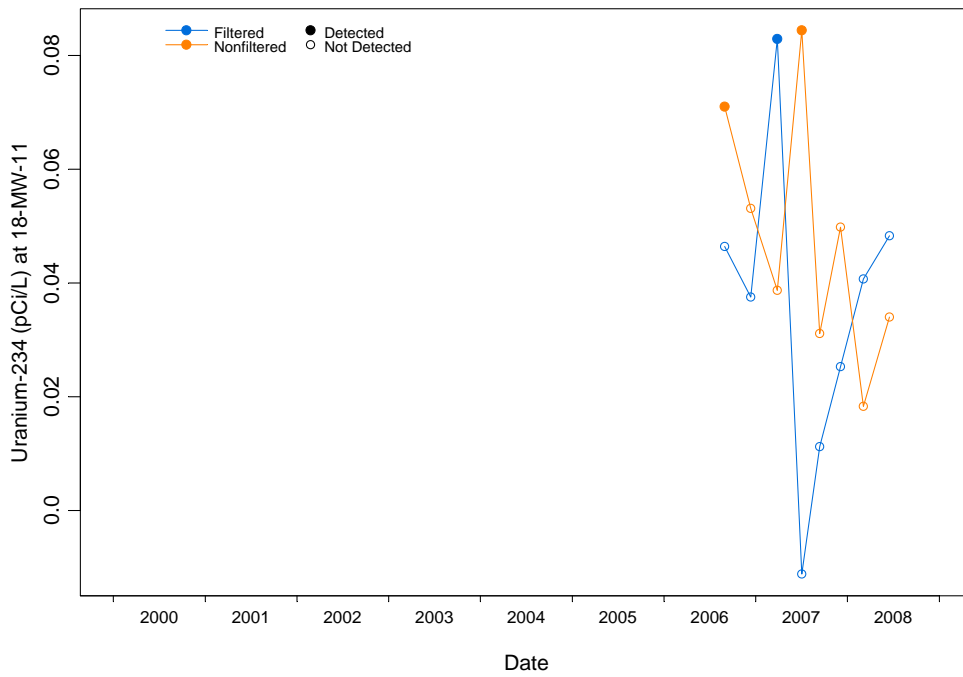

Figure D-2.2-24 Concentrations over time at 18-MW-11 for uranium-234

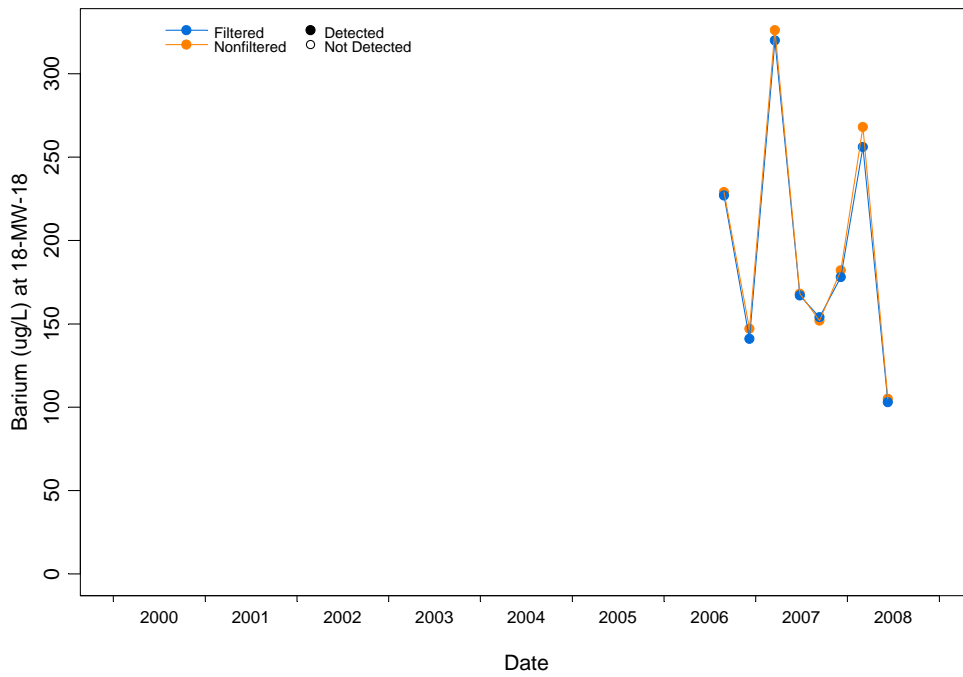

Figure D-2.2-25 Concentrations over time at 18-MW-18 for barium

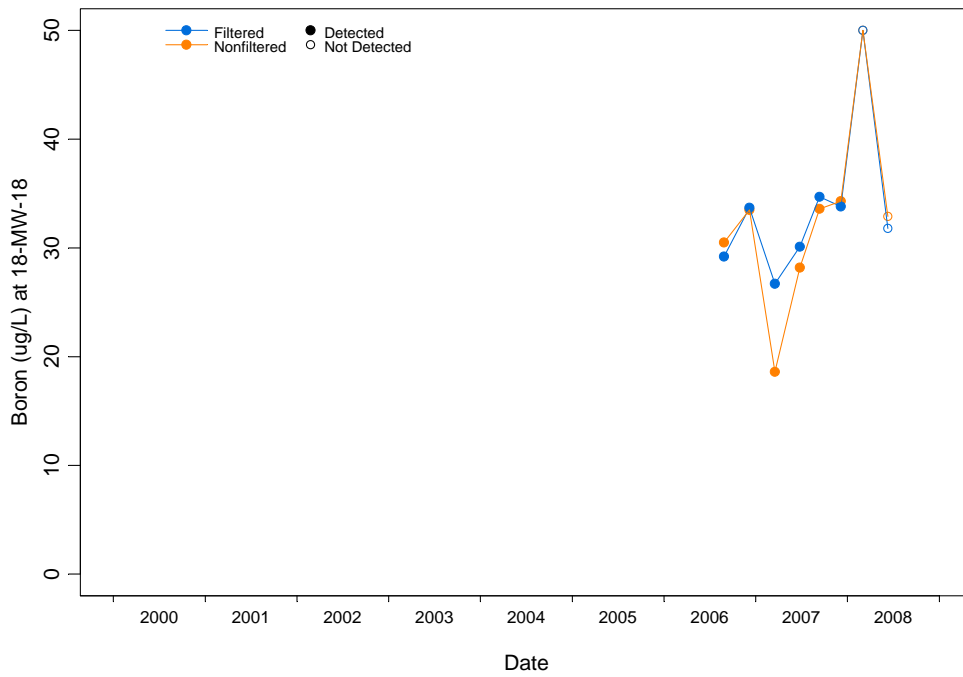

Figure D-2.2-26 Concentrations over time at 18-MW-18 for boron

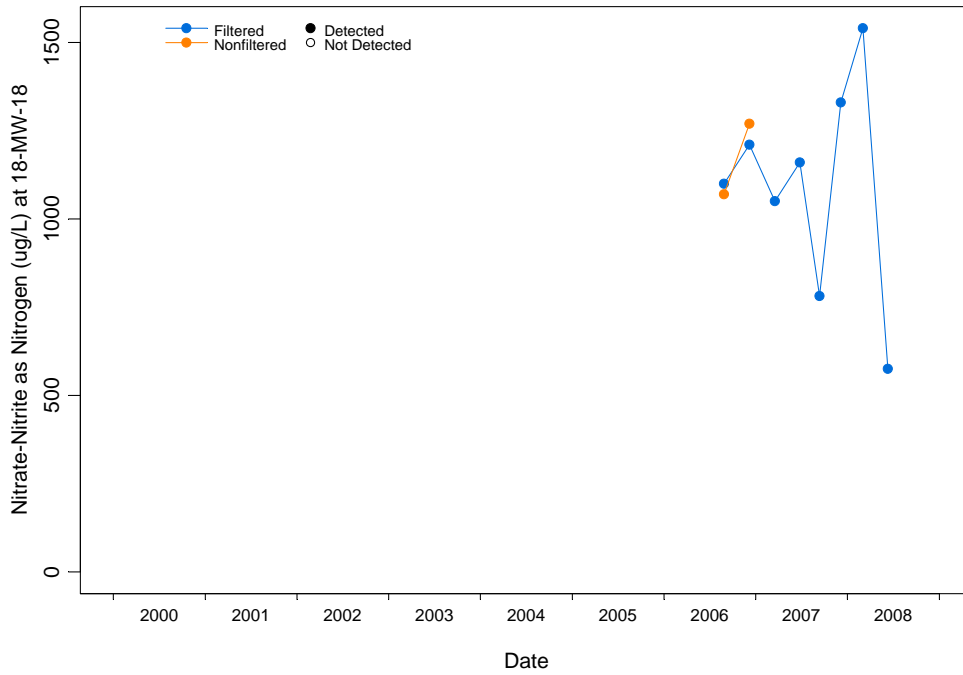

Figure D-2.2-27 Concentrations over time at 18-MW-18 for nitrate-nitrite as nitrogen

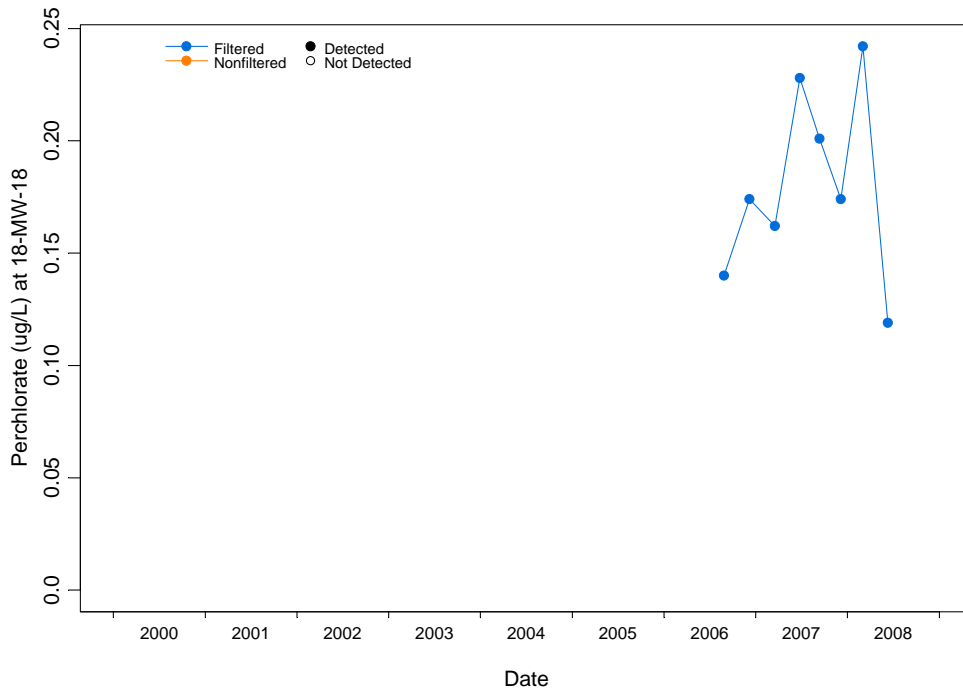

Figure D-2.2-28 Concentrations over time at 18-MW-18 for perchlorate

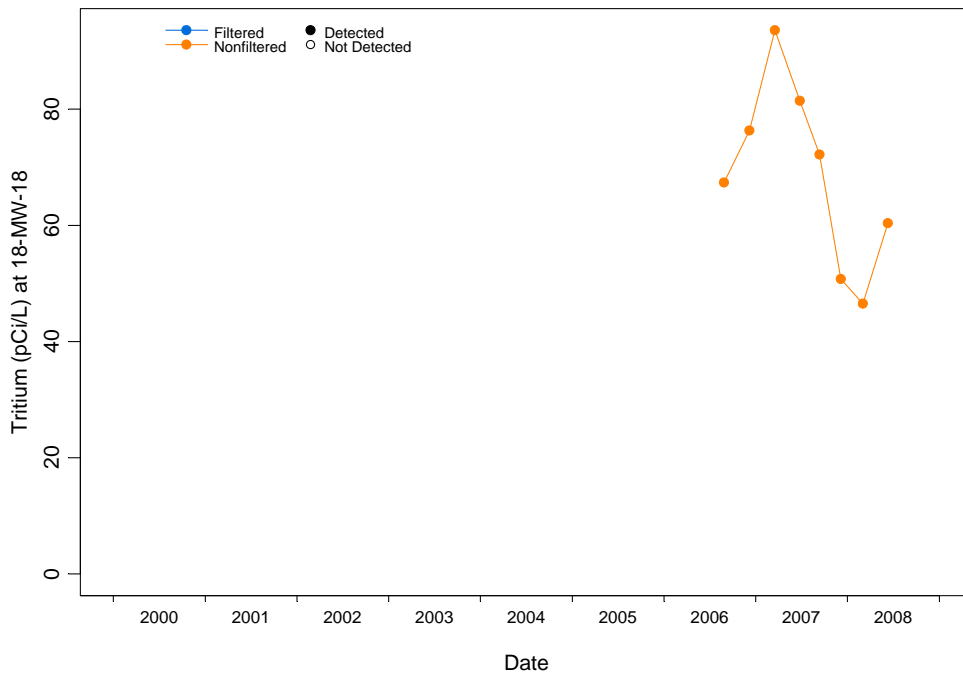

Figure D-2.2-29 Concentrations over time at 18-MW-18 for tritium

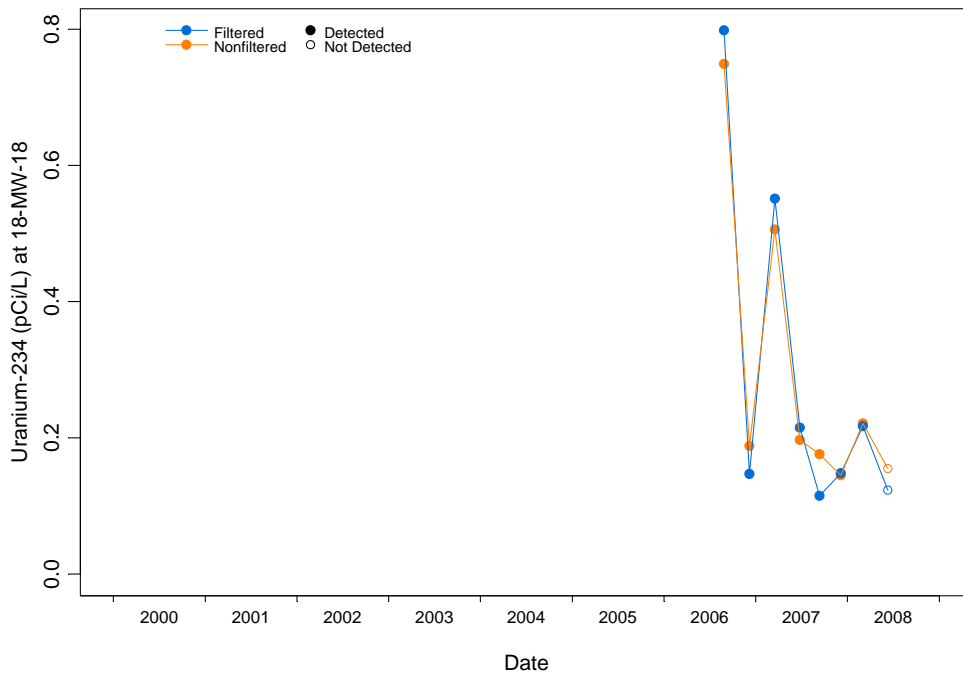

Figure D-2.2-30 Concentrations over time at 18-MW-18 for uranium-234

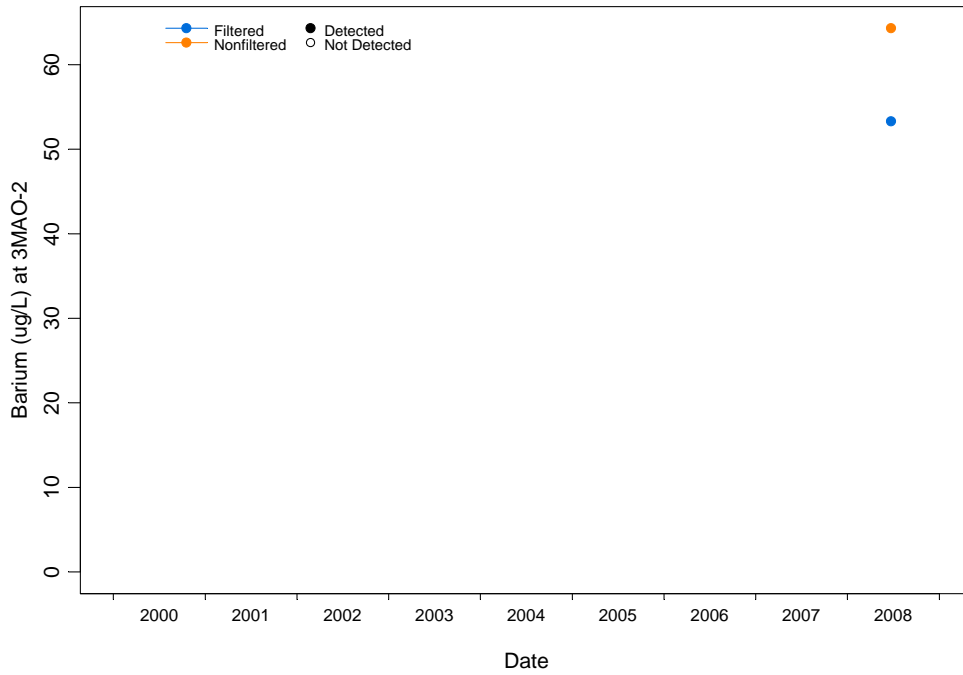

Figure D-2.2-31 Concentrations over time at 3MAO-2 for barium

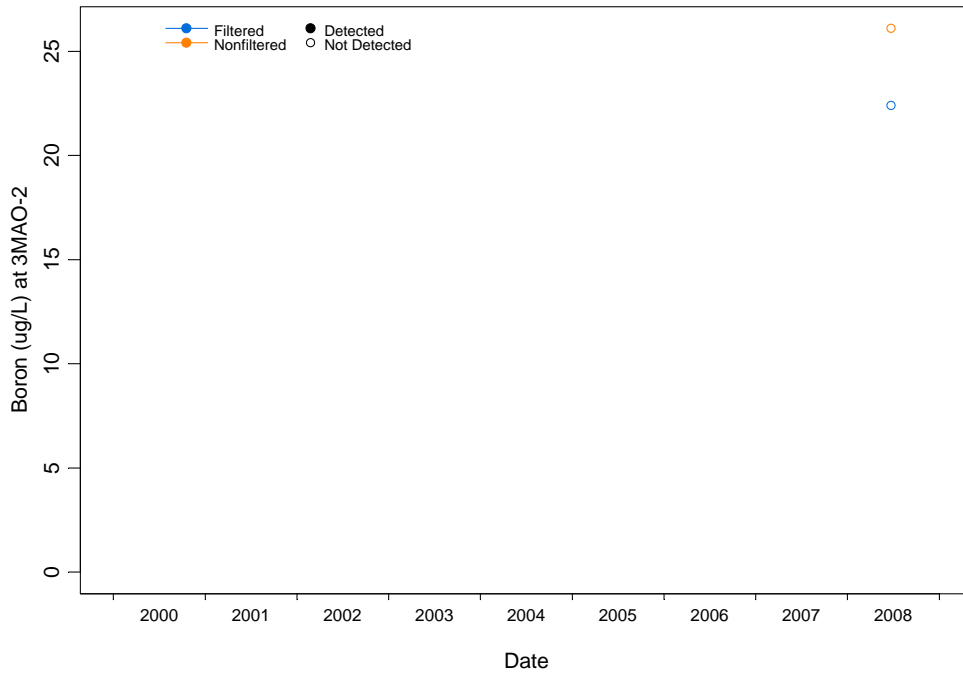

Figure D-2.2-32 Concentrations over time at 3MAO-2 for boron

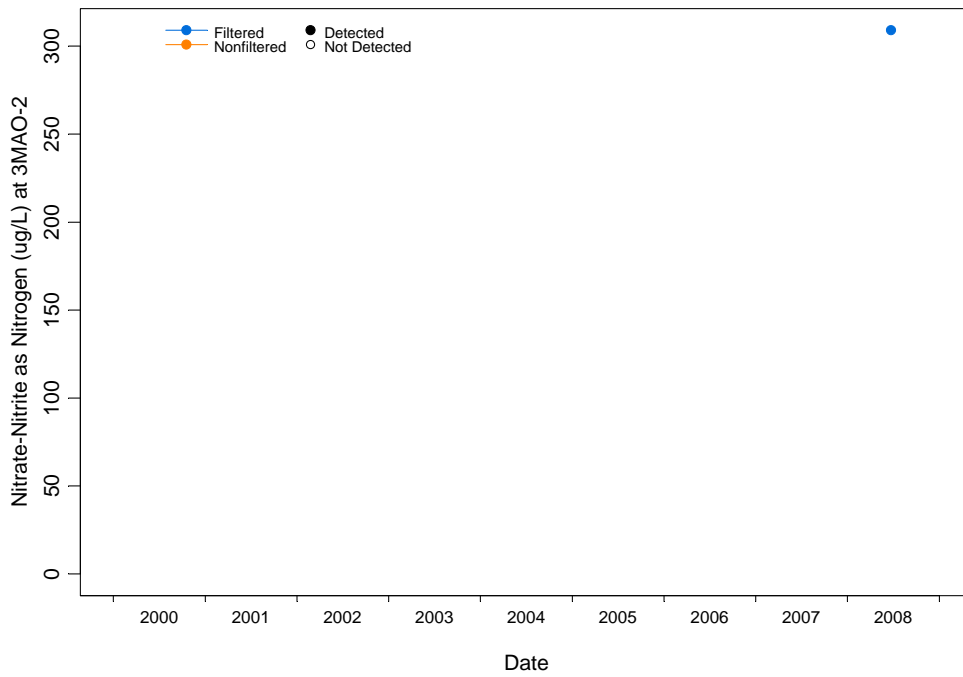

Figure D-2.2-33 Concentrations over time at 3MAO-2 for nitrate-nitrite as nitrogen

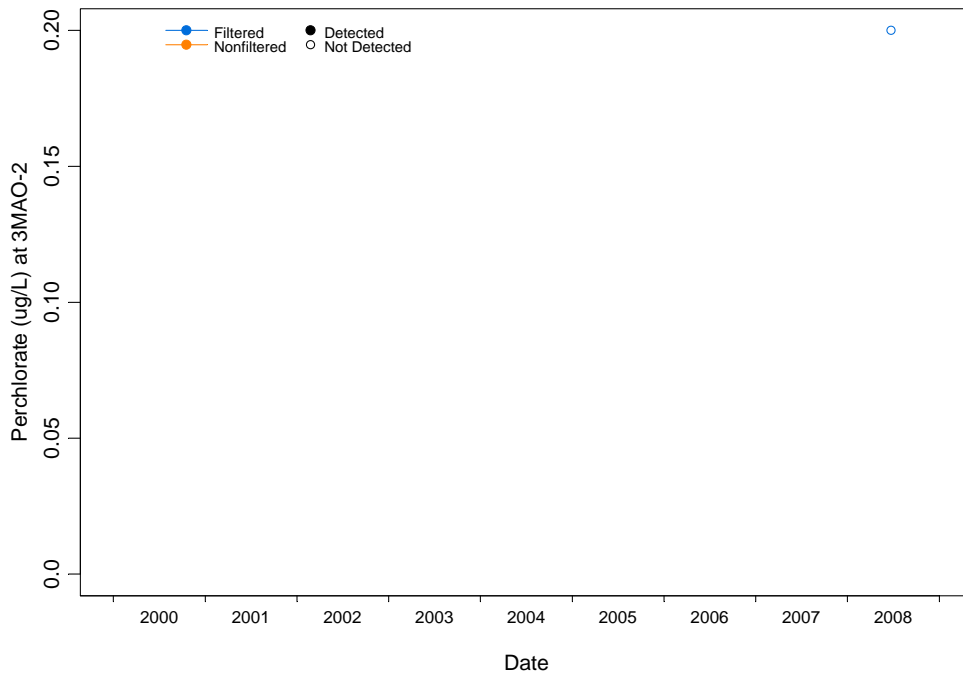

Figure D-2.2-34 Concentrations over time at 3MAO-2 for perchlorate

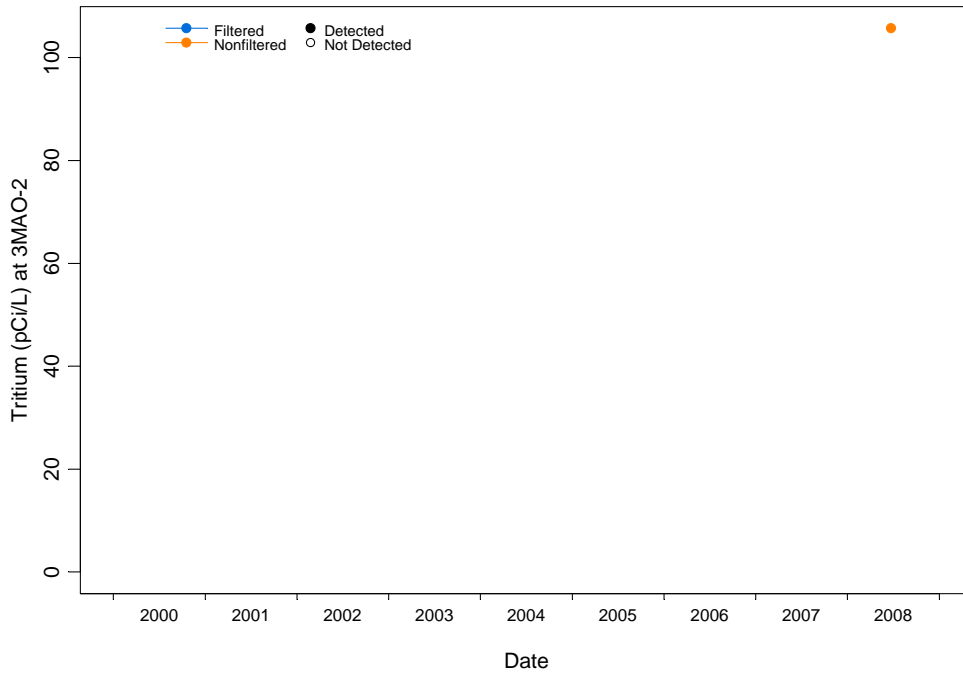

Figure D-2.2-35 Concentrations over time at 3MAO-2 for tritium

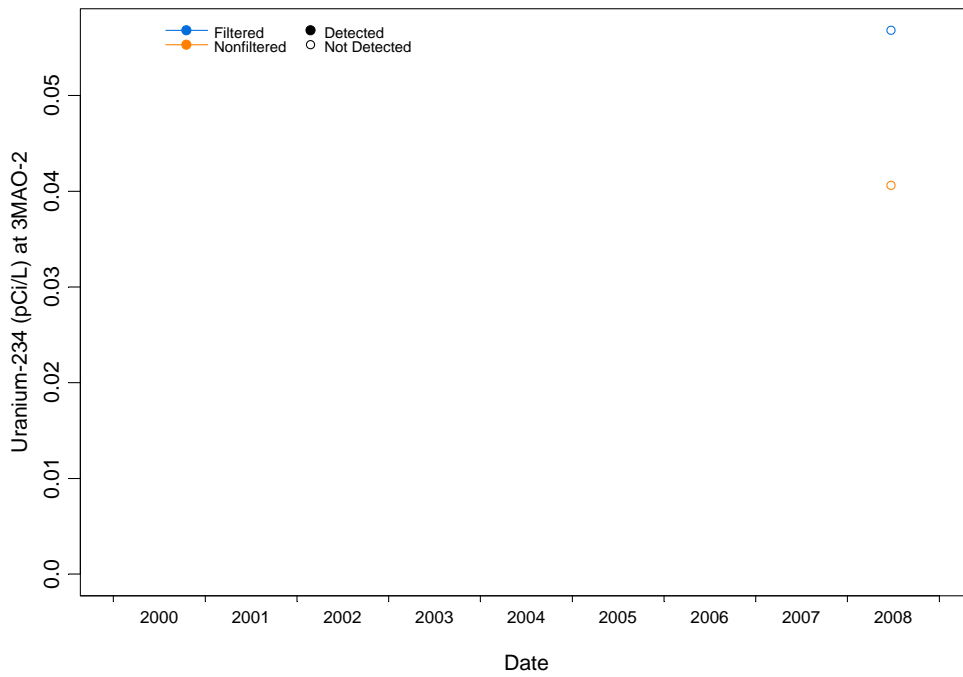

Figure D-2.2-36 Concentrations over time at 3MAO-2 for uranium-234

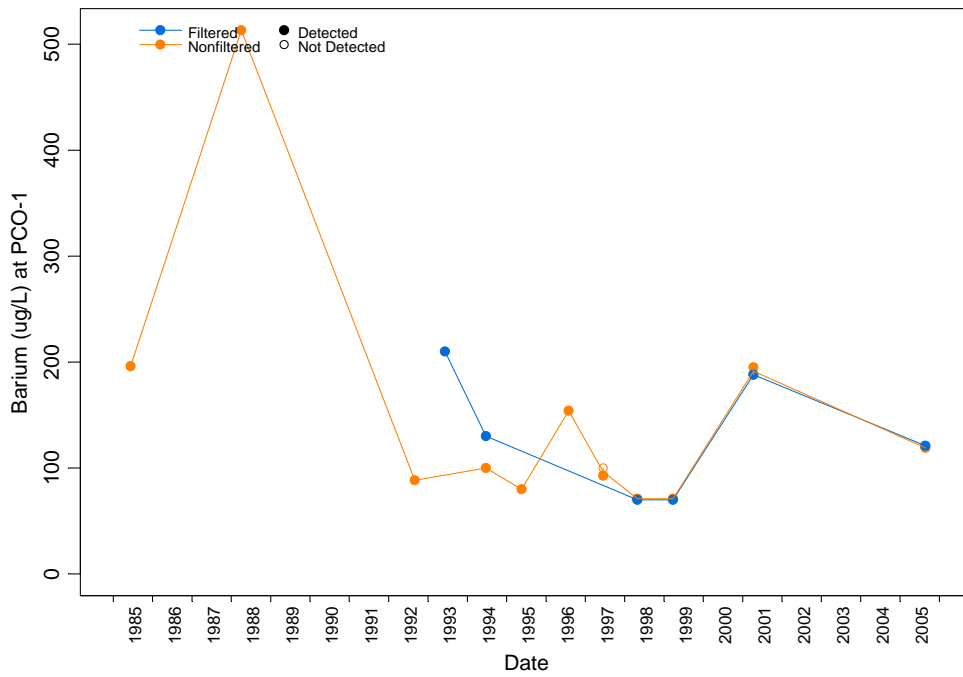

Figure D-2.2-37 Concentrations over time at PCO-1 for barium

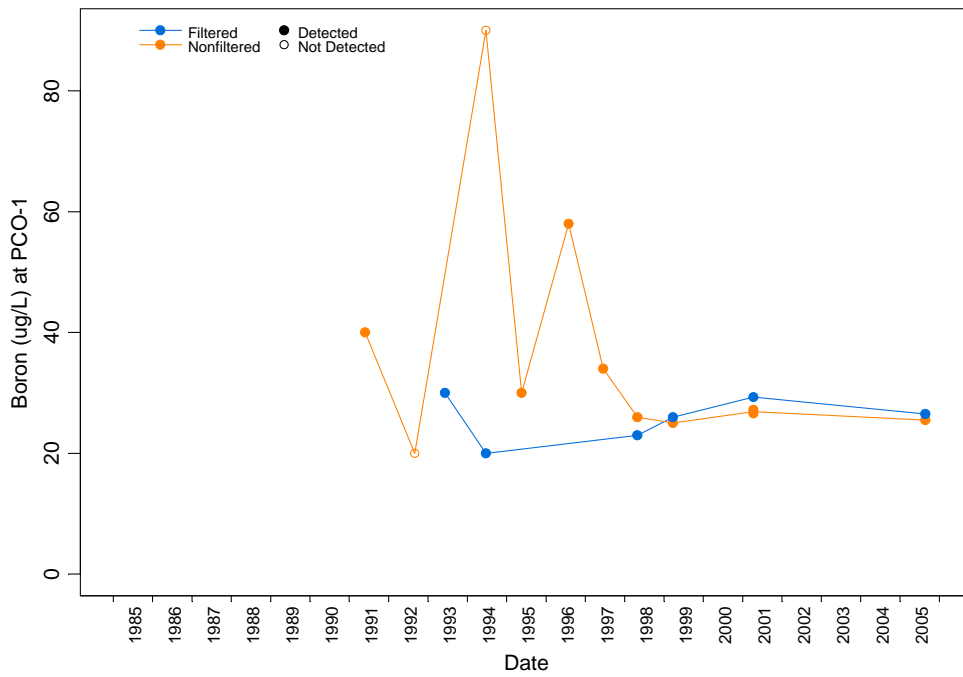

Figure D-2.2-38 Concentrations over time at PCO-1 for boron

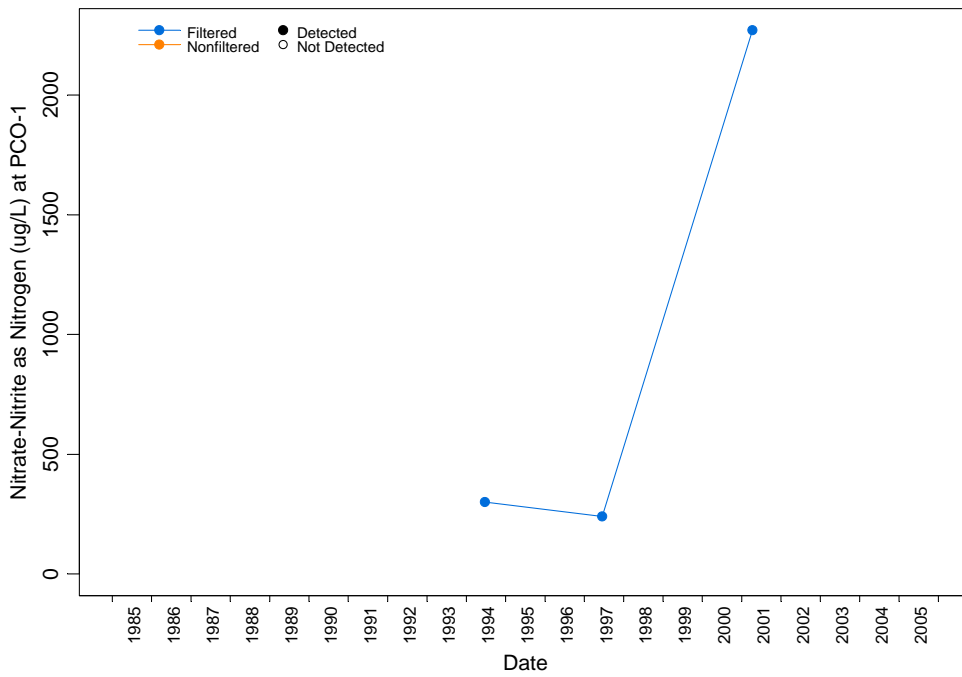

Figure D-2.2-39 Concentrations over time at PCO-1 for nitrate-nitrite as nitrogen

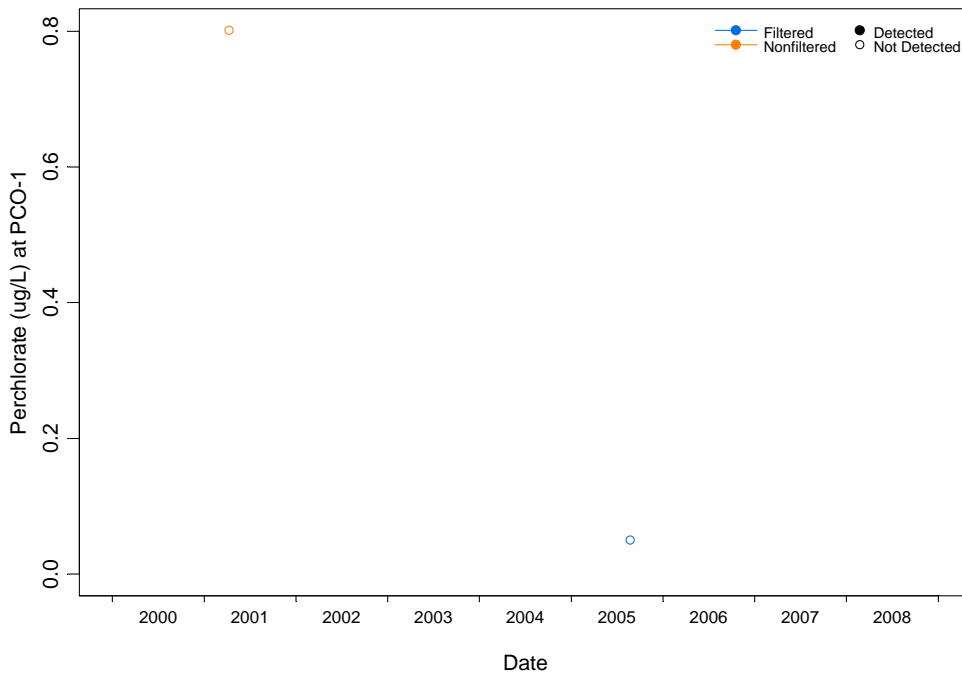

Figure D-2.2-40 Concentrations over time at PCO-1 for perchlorate - analytical method before 2004 is EPA:314, analytical method post-2003 is SW-846:6850

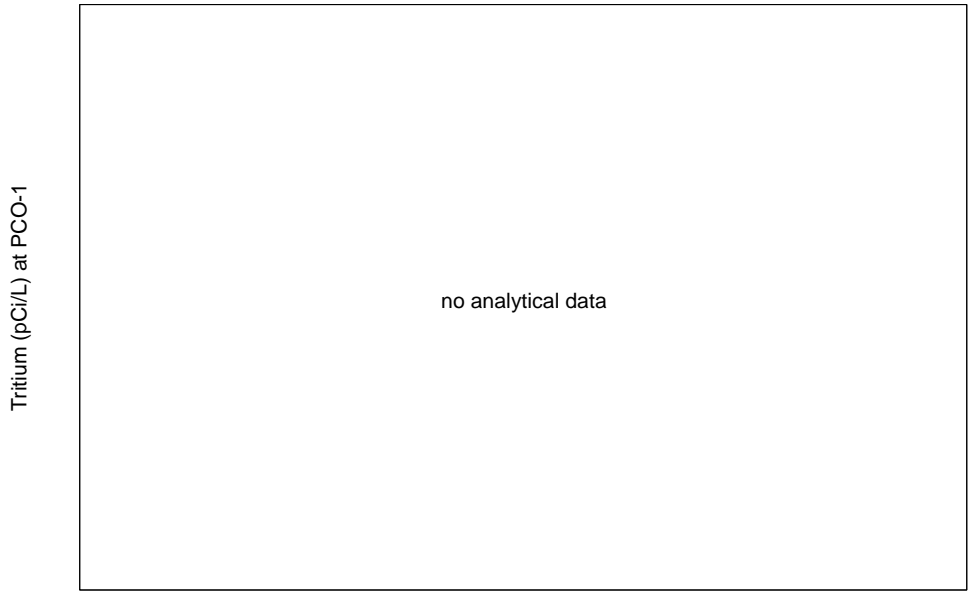

Figure D-2.2-41 Tritium at PCO-1 - No analytical data

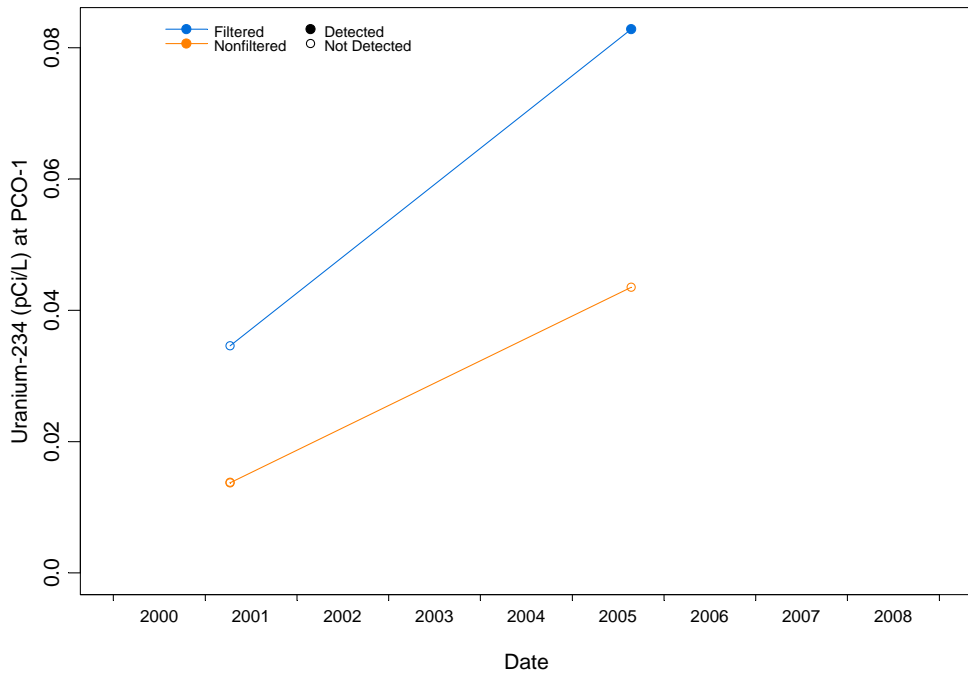

Figure D-2.2-42 Concentrations over time at PCO-1 for uranium-234

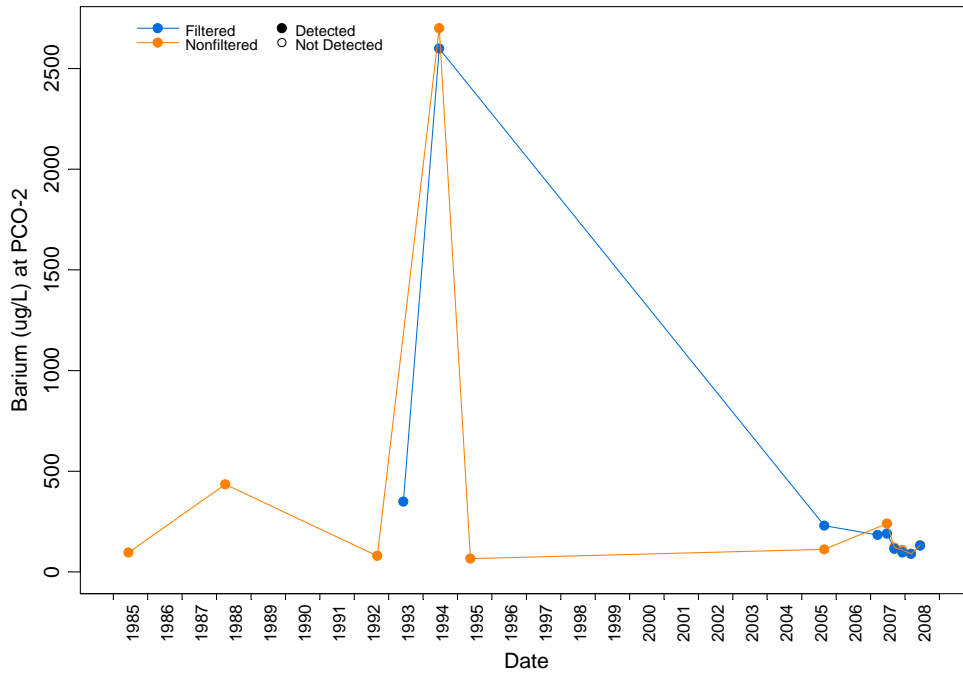

Figure D-2.2-43 Concentrations over time at PCO-2 for barium

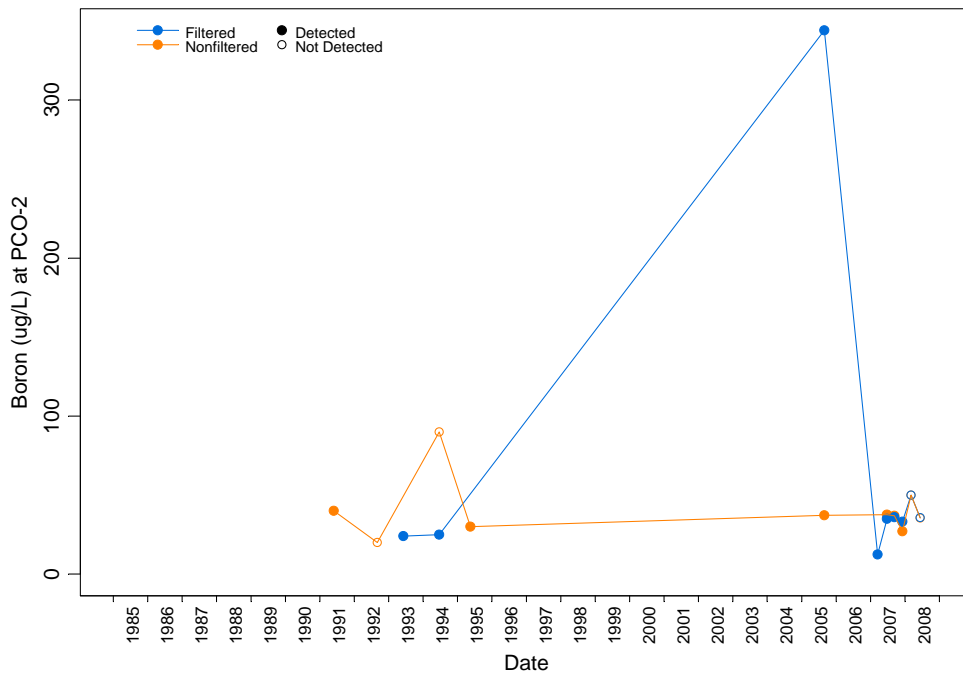

Figure D-2.2-44 Concentrations over time at PCO-2 for boron

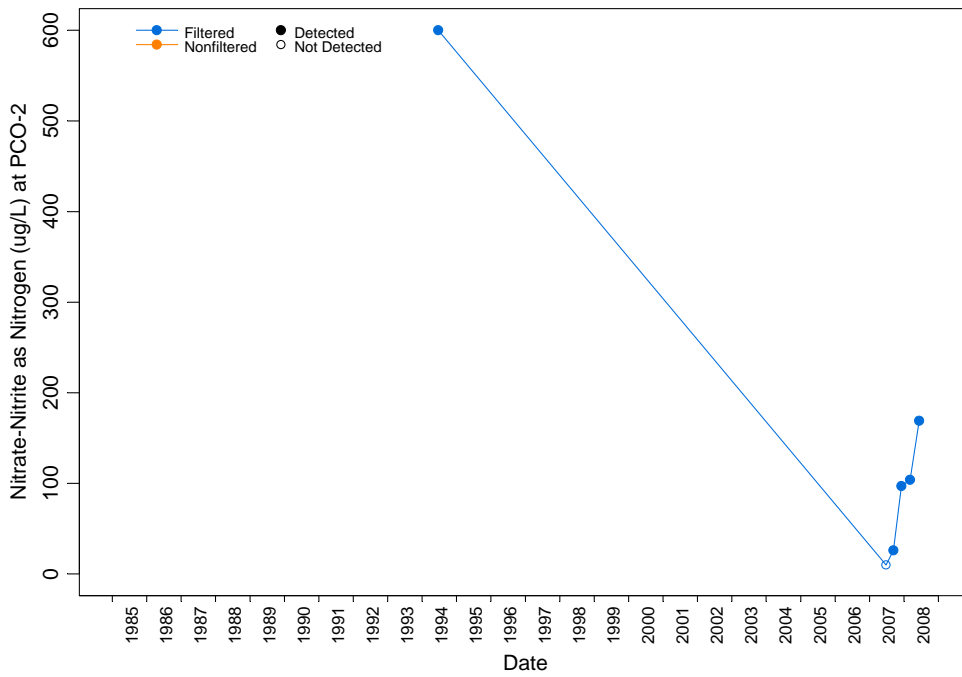

Figure D-2.2-45 Concentrations over time at PCO-2 for nitrate-nitrite as nitrogen

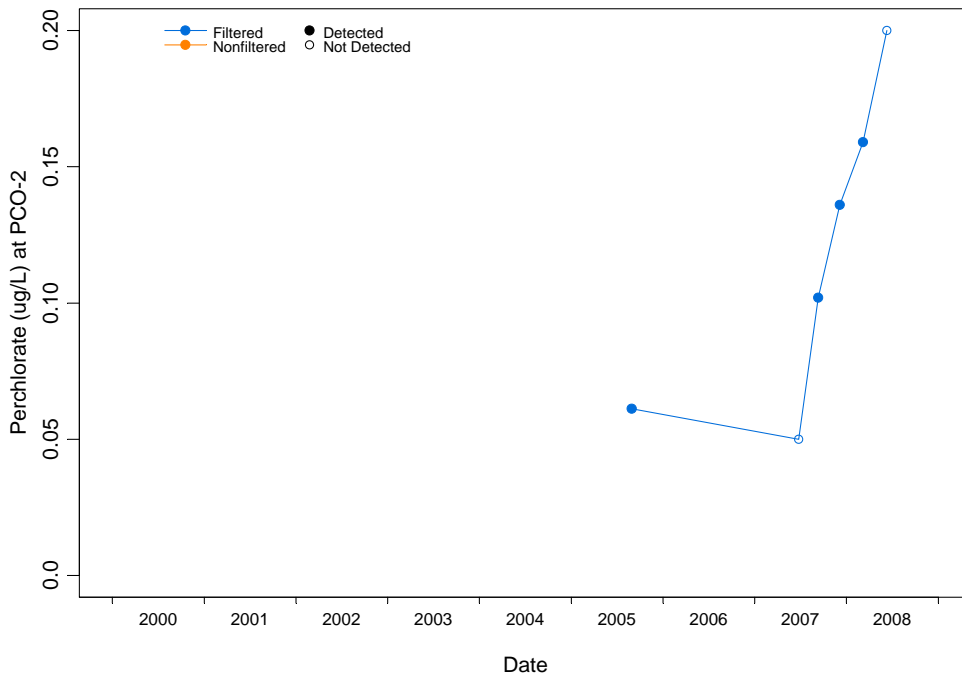

Figure D-2.2-46 Concentrations over time at PCO-2 for perchlorate

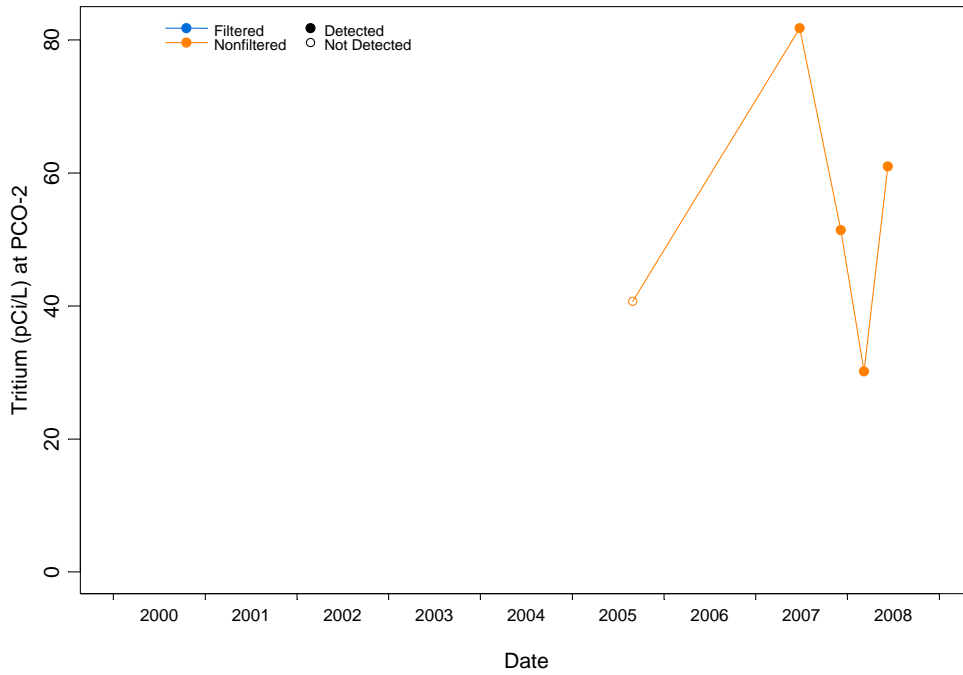

Figure D-2.2-47 Concentrations over time at PCO-2 for tritium

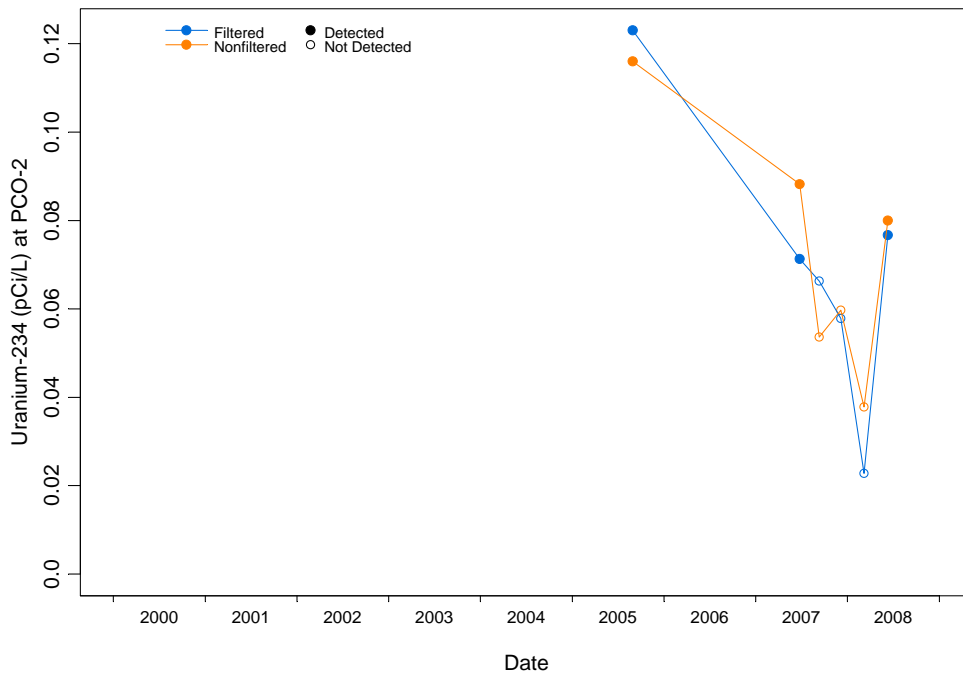

Figure D-2.2-48 Concentrations over time at PCO-2 for uranium-234

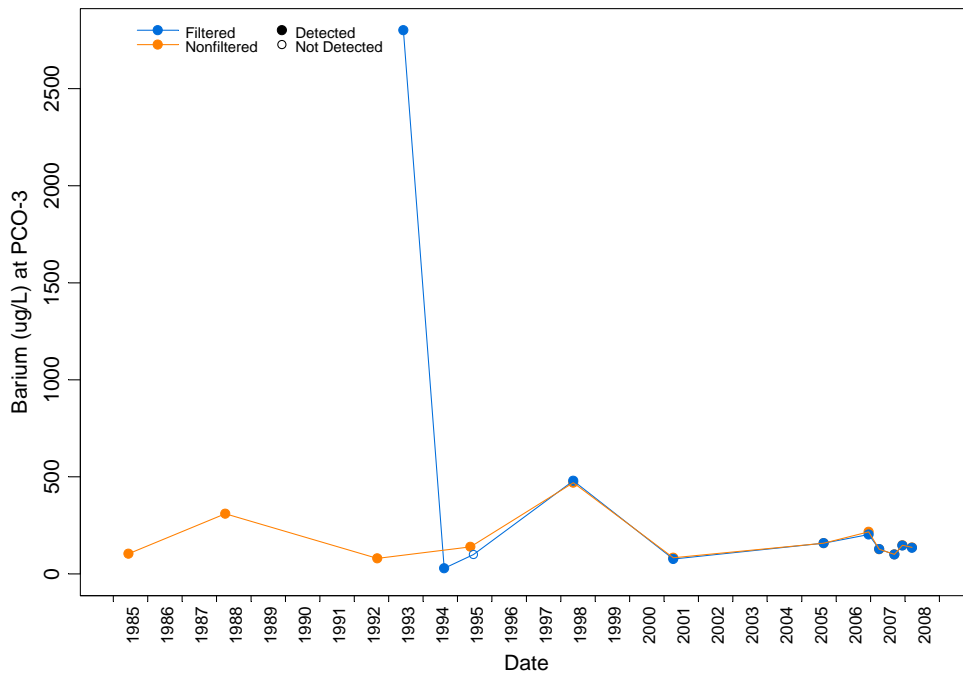

Figure D-2.2-49 Concentrations over time at PCO-3 for barium

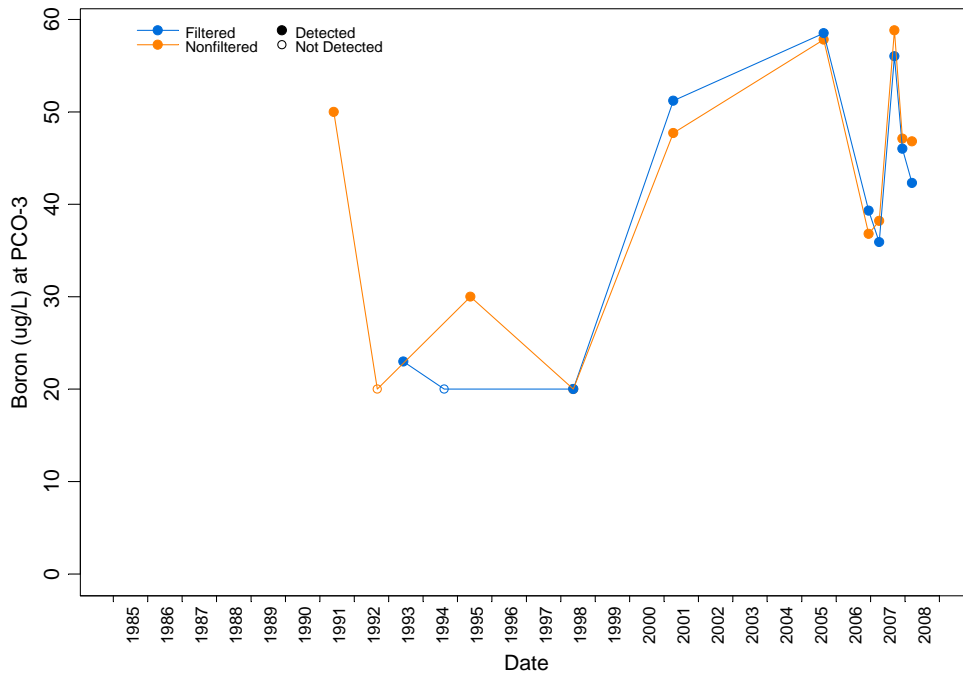

Figure D-2.2-50 Concentrations over time at PCO-3 for boron

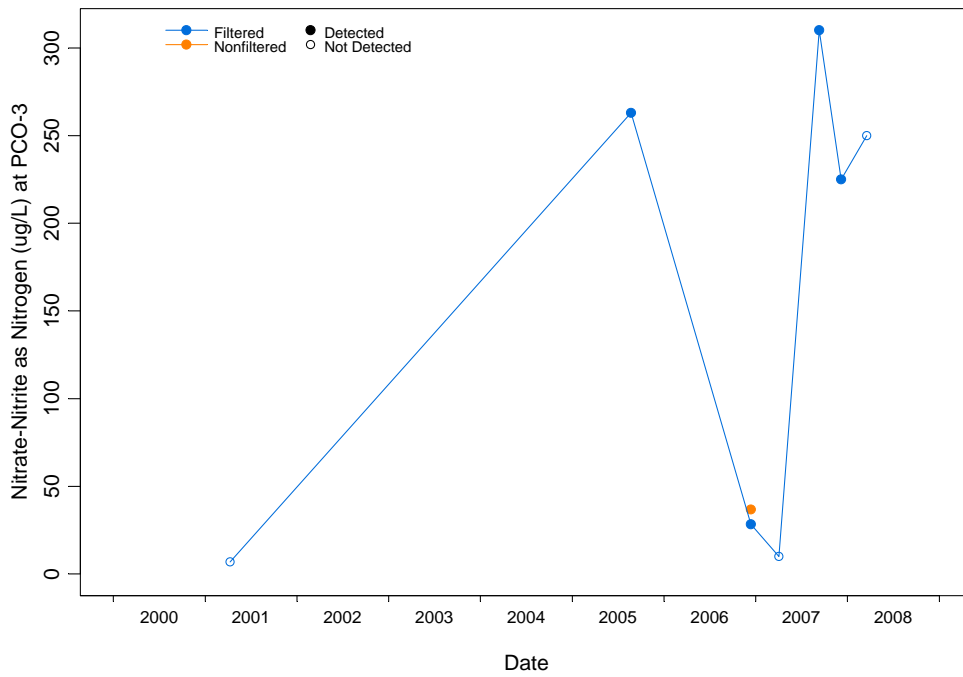

Figure D-2.2-51 Concentrations over time at PCO-3 for nitrate-nitrite as nitrogen

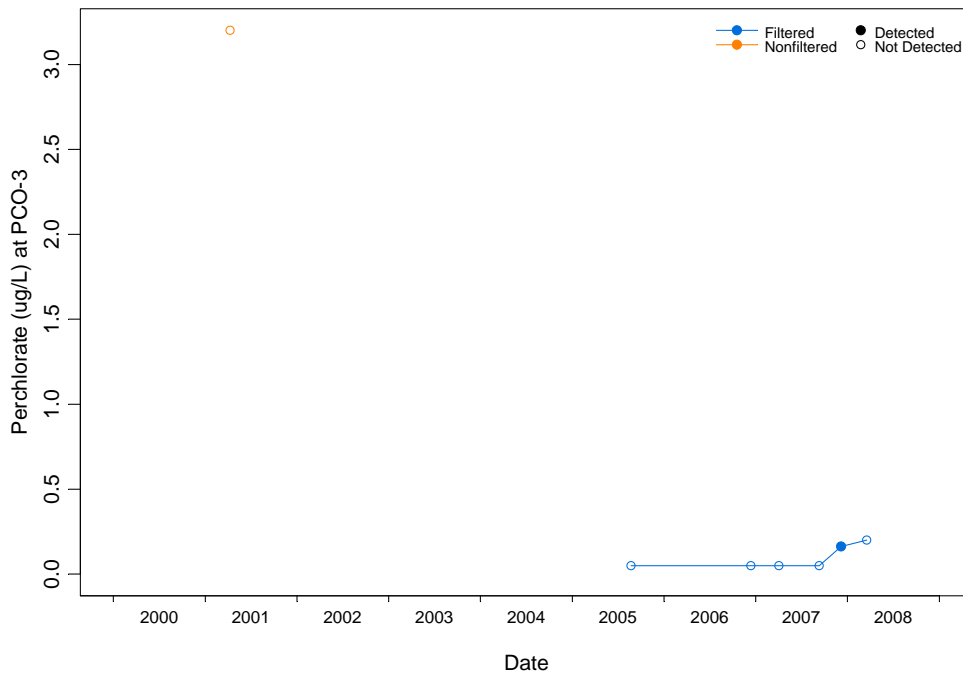

Figure D-2.2-52 Concentrations over time at PCO-3 for perchlorate - analytical method prior to 2004 is EPA:314, analytical method post 2003 is SW-846:6850

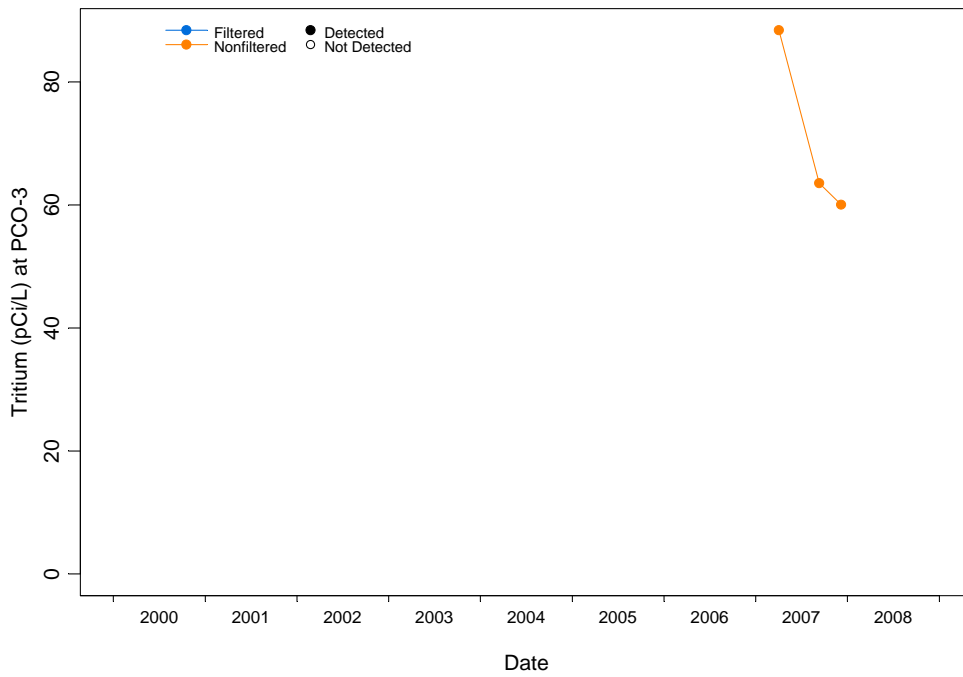

Figure D-2.2-53 Concentrations over time at PCO-3 for tritium

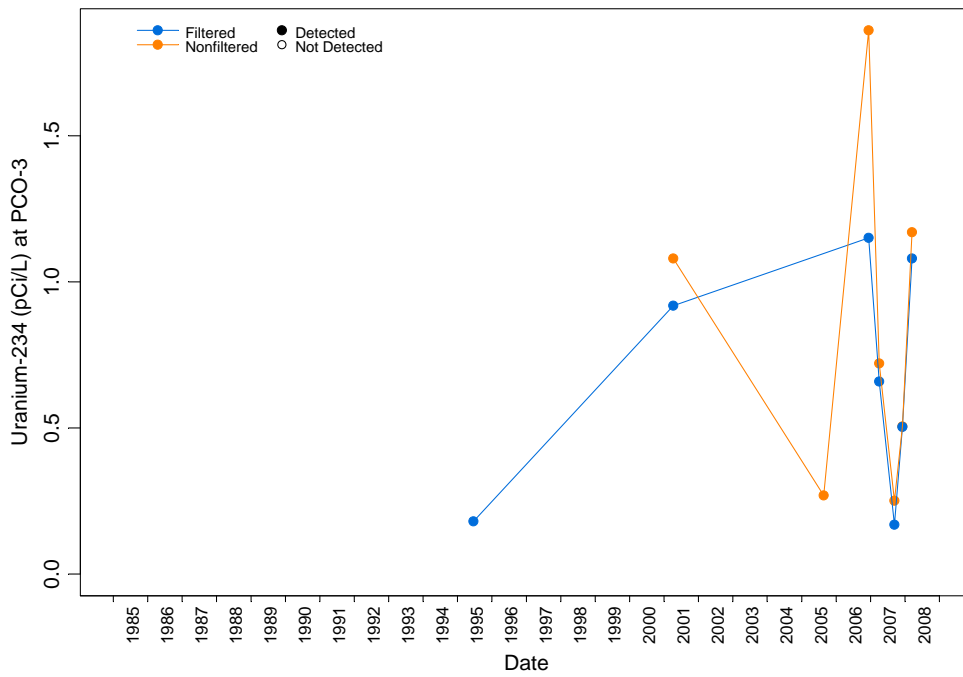

Figure D-2.2-54 Concentrations over time at PCO-3 for uranium-234

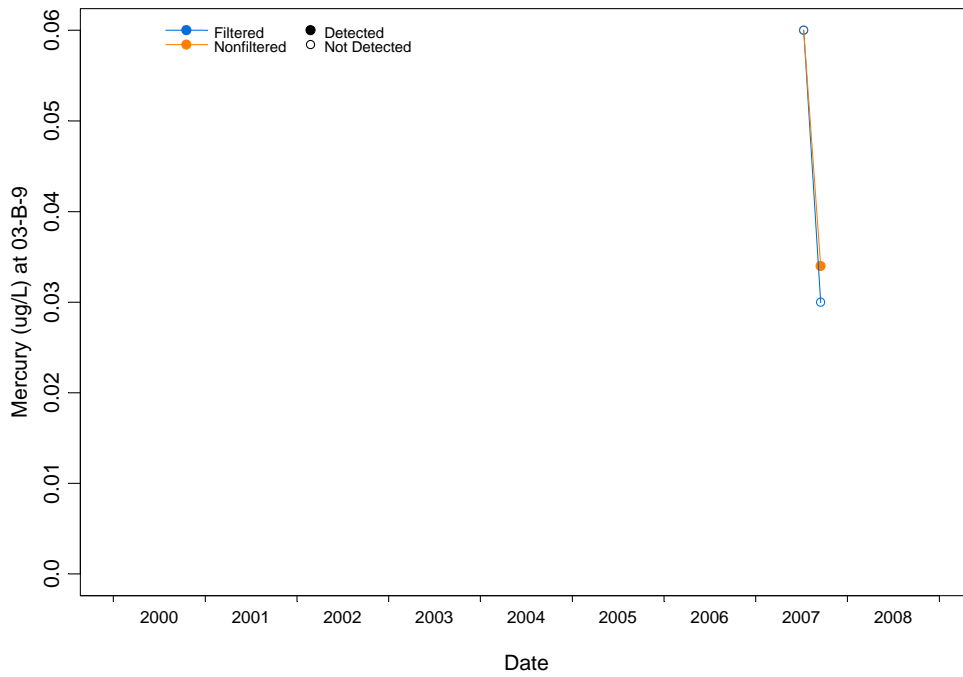

Figure D-2.2-55 Concentrations over time at 03-B-9 for mercury

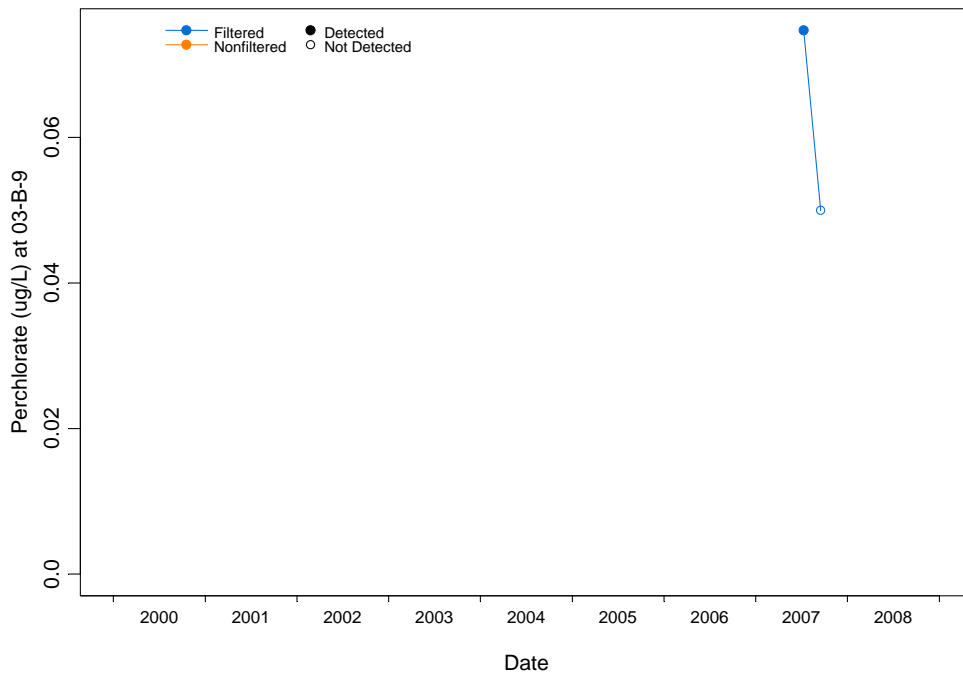

Figure D-2.2-56 Concentrations over time at 03-B-9 for perchlorate

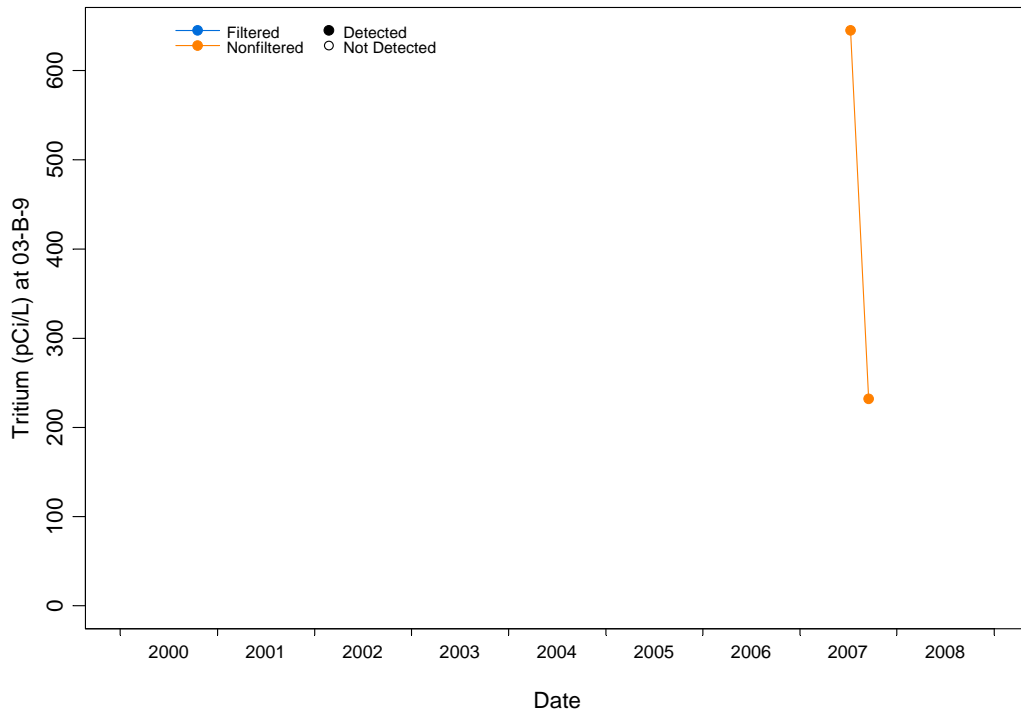

Figure D-2.2-57 Concentrations over time at 03-B-9 for tritium

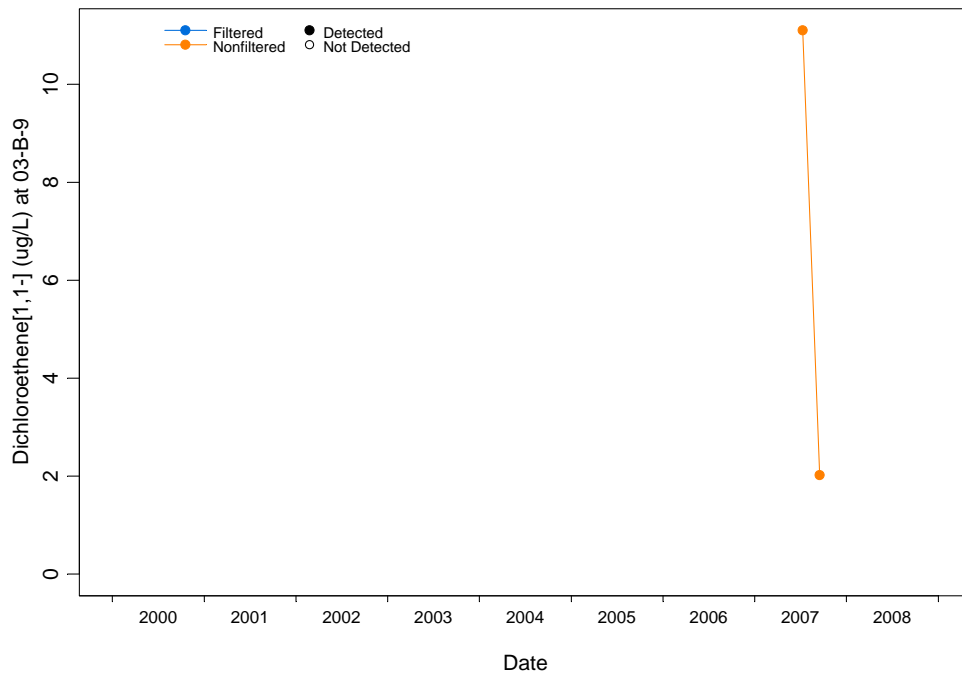

Figure D-2.2-58 Concentrations over time at 03-B-9 for dichloroethene[1,1-]

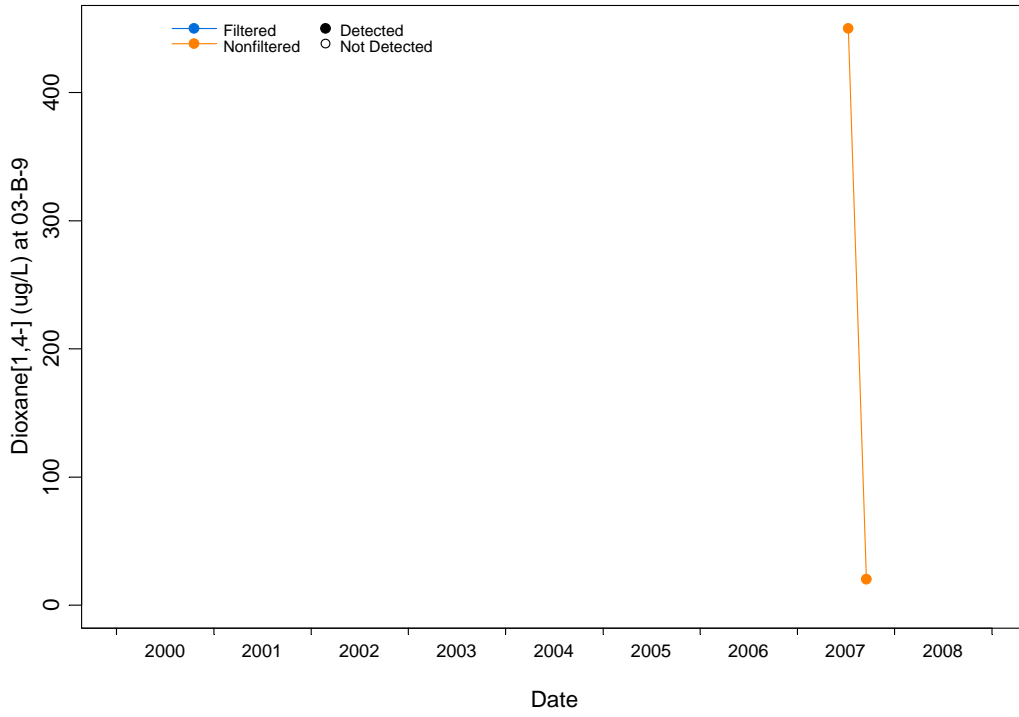

Figure D-2.2-59 Concentrations over time at 03-B-9 for dioxane[1,4-]

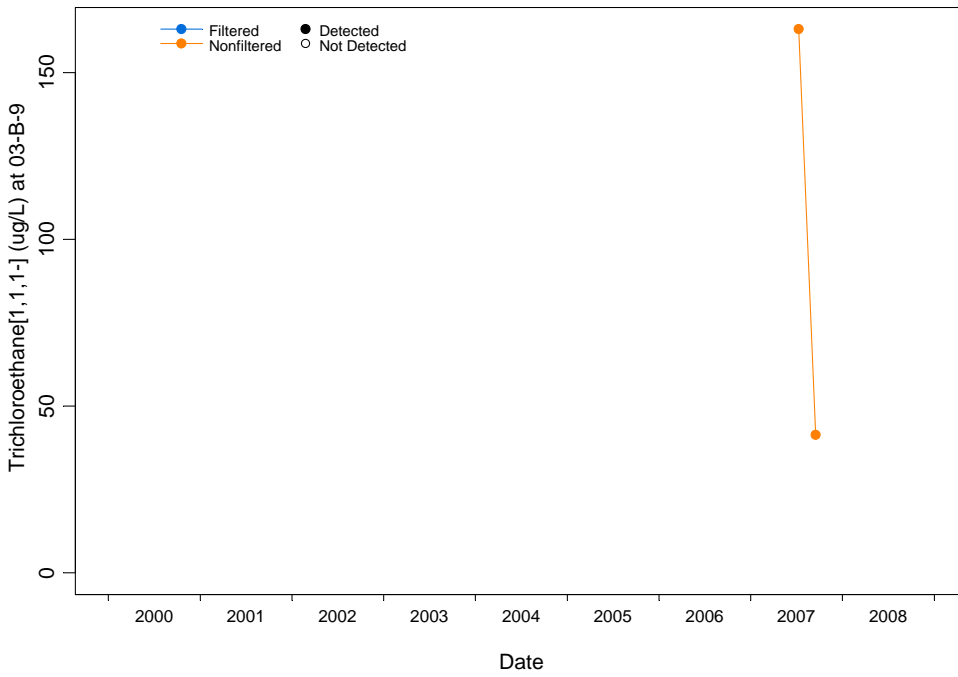

Figure D-2.2-60 Concentrations over time at 03-B-9 for trichloroethane[1,1,1-]

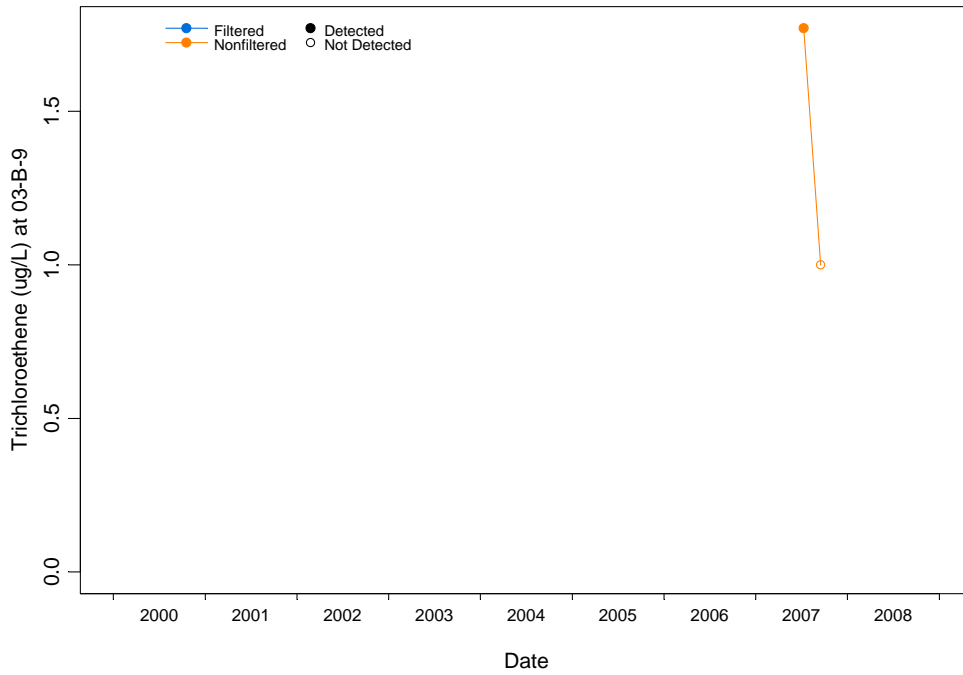

Figure D-2.2-61 Concentrations over time at 03-B-9 for trichloroethene

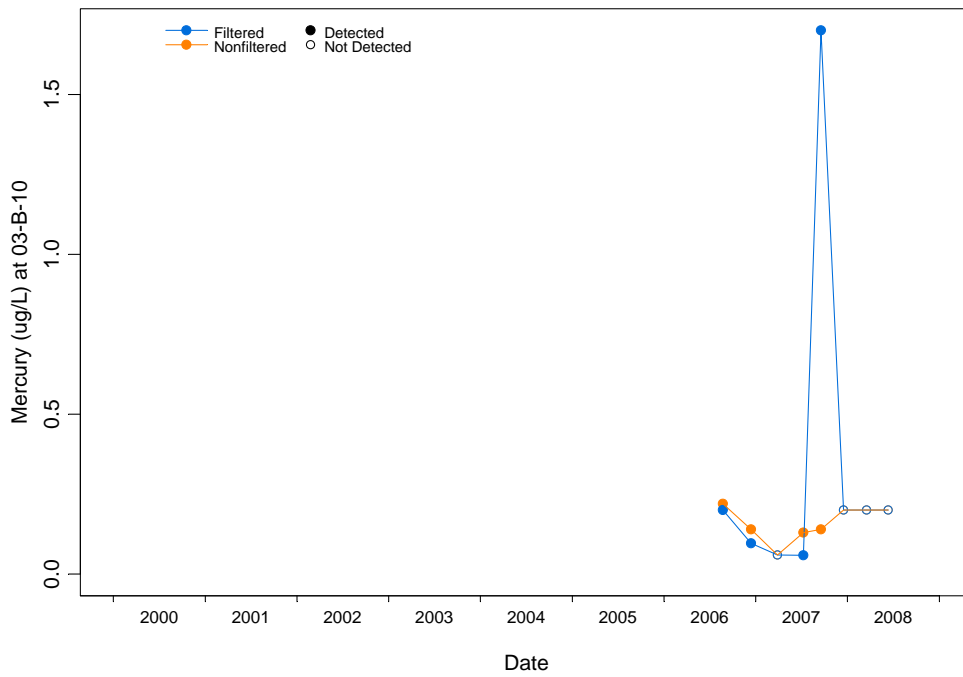

Figure D-2.2-62 Concentrations over time at 03-B-10 for mercury

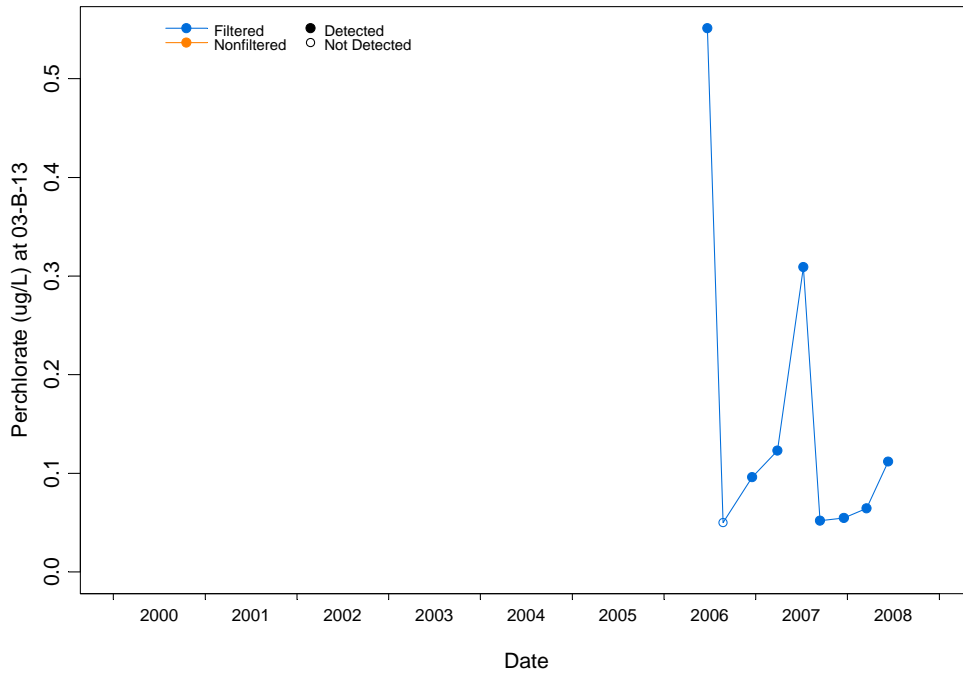

Figure D-2.2-63 Concentrations over time at 03-B-10 for perchlorate

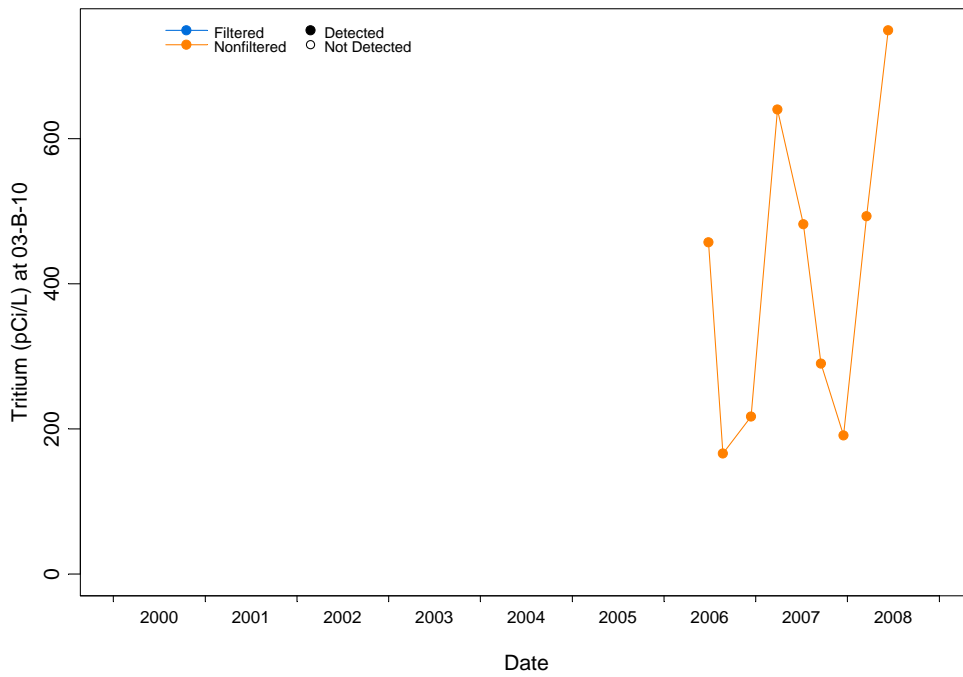

Figure D-2.2-64 Concentrations over time at 03-B-10 for tritium

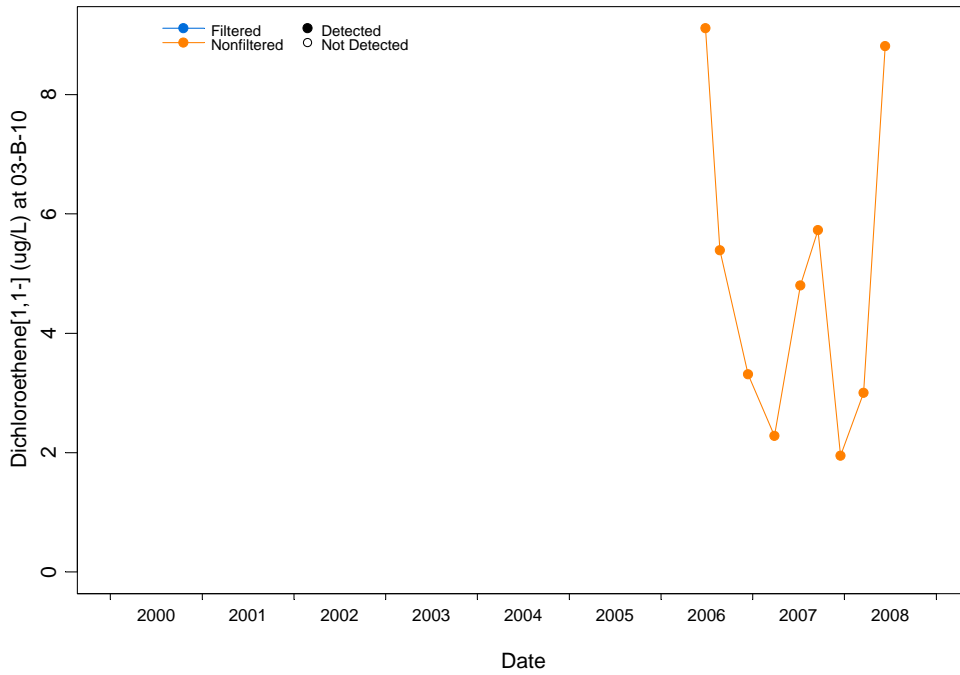

Figure D-2.2-65 Concentrations over time at 03-B-10 for dichloroethene[1,1,1-]

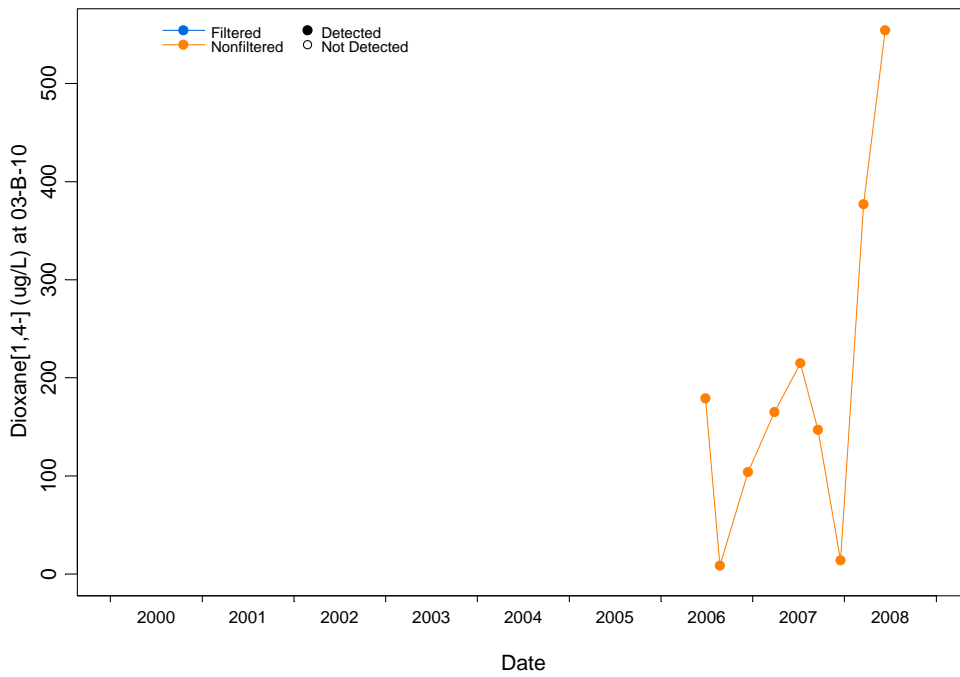

Figure D-2.2-66 Concentrations over time at 03-B-10 for dioxane[1,4-]

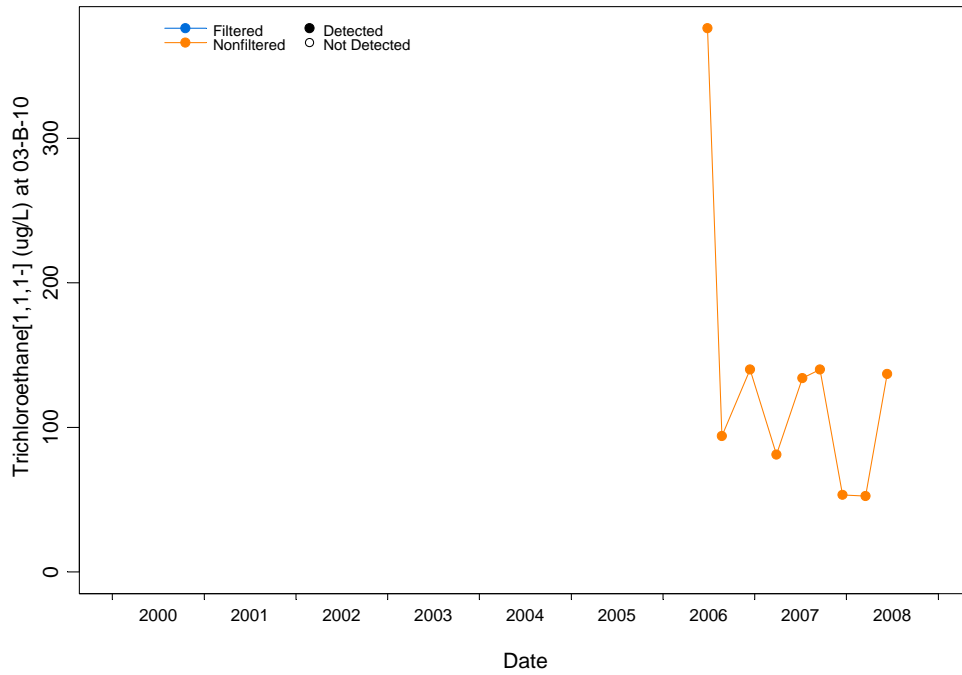

Figure D-2.2-67 Concentrations over time at 03-B-10 for trichloroethane[1,1,1-]

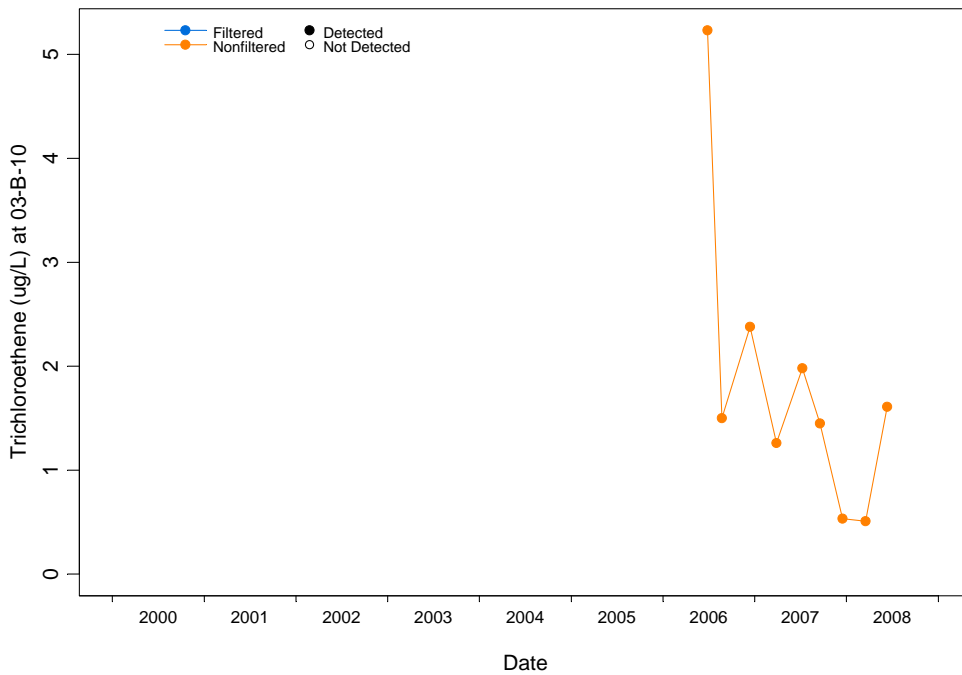

Figure D-2.2-68 Concentrations over time at 03-B-10 for trichloroethene

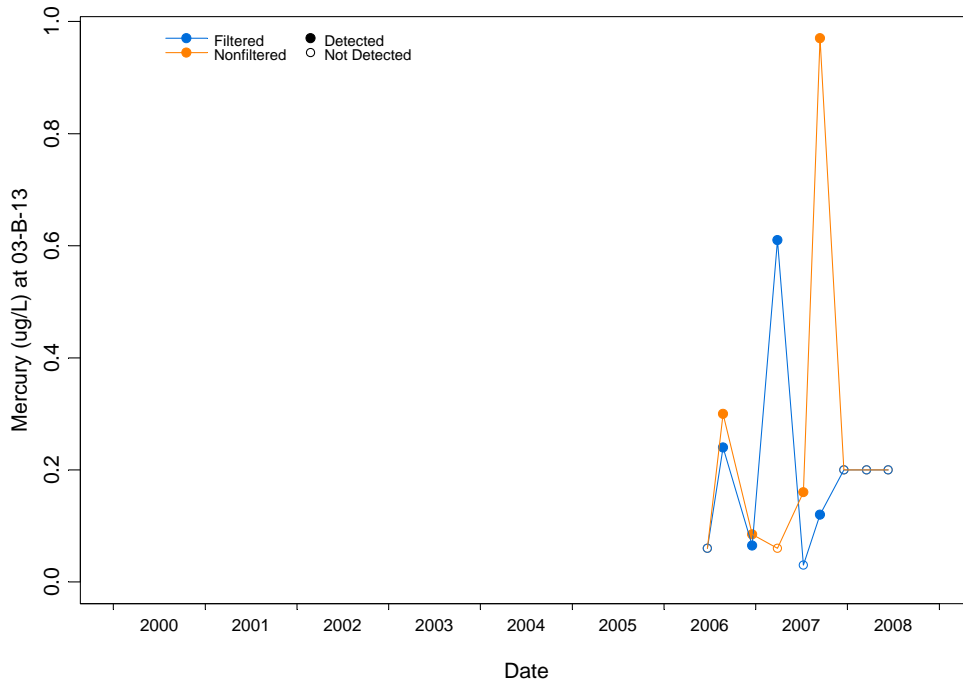

Figure D-2.2-69 Concentrations over time at 03-B-13 for mercury

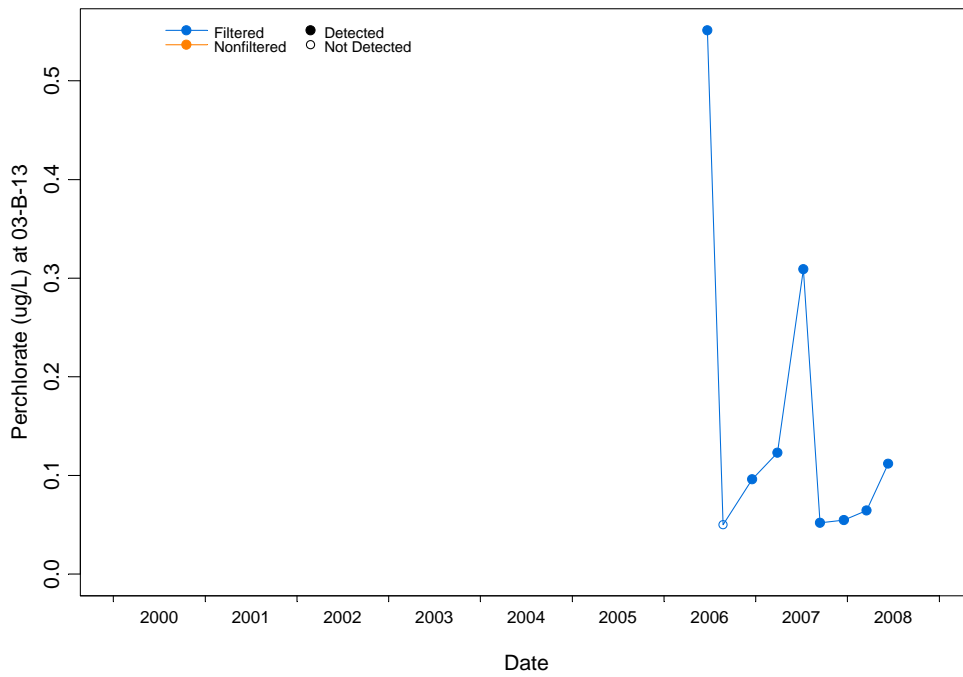

Figure D-2.2-70 Concentrations over time at 03-B-13 for perchlorate

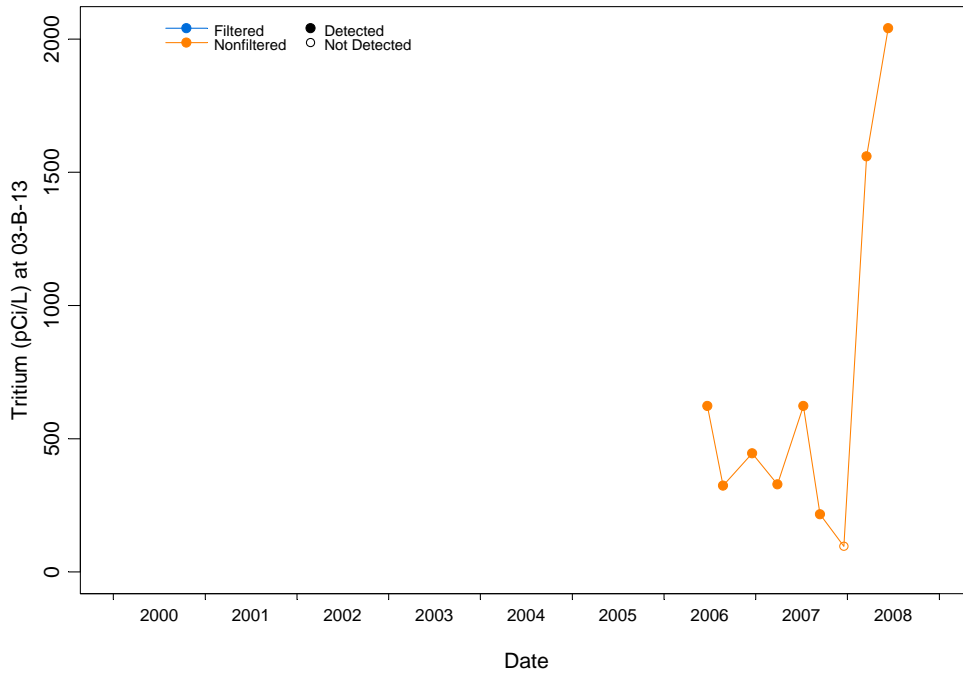

Figure D-2.2-71 Concentrations over time at 03-B-13 for tritium

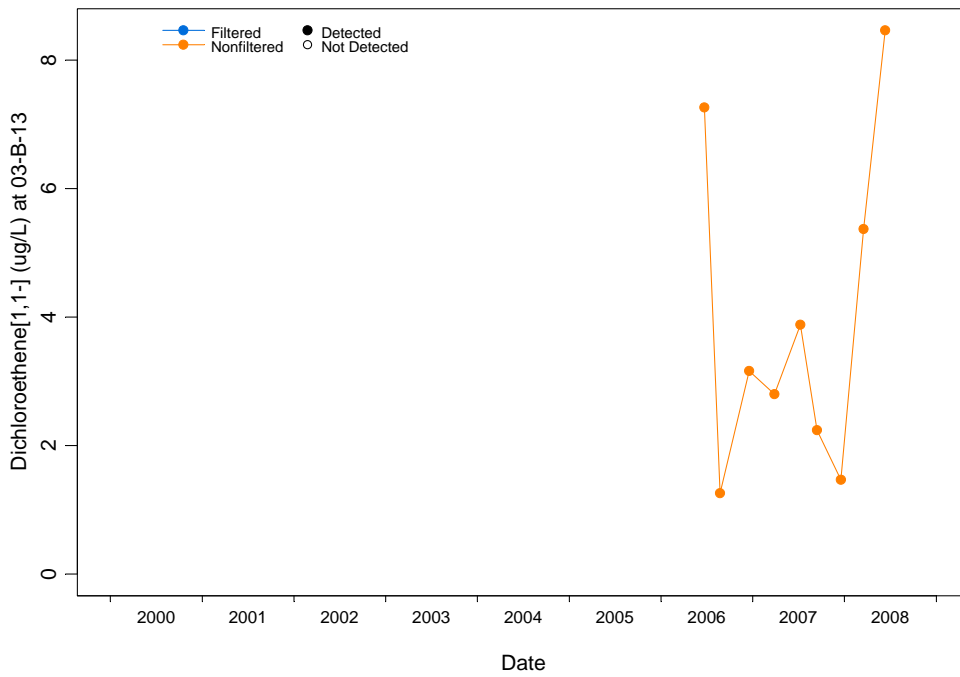

Figure D-2.2-72 Concentrations over time at 03-B-13 for dichloroethene[1,1-]

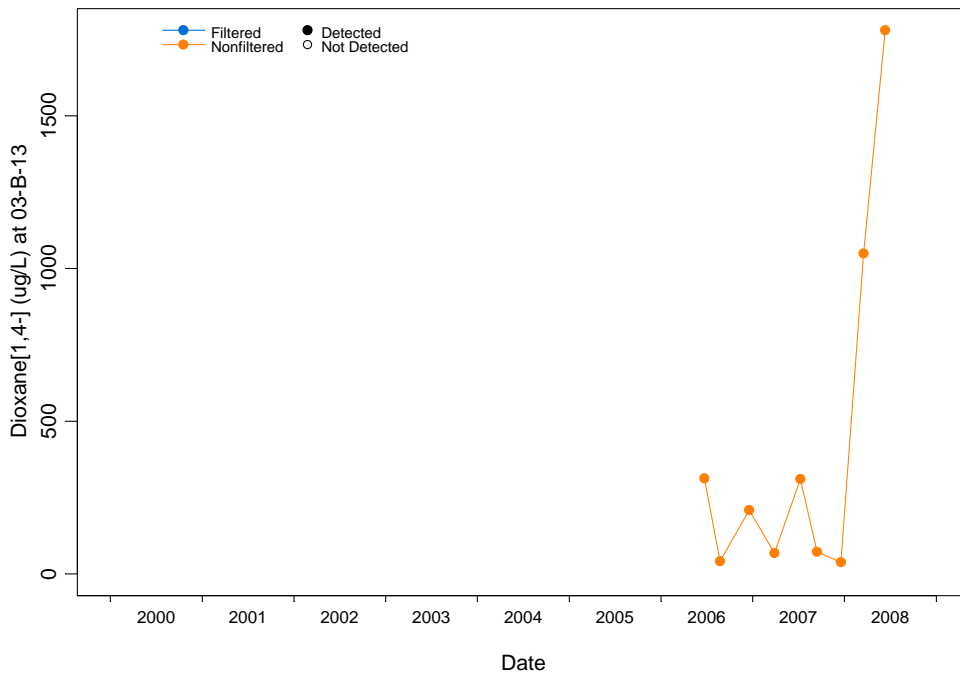

Figure D-2.2-73 Concentrations over time at 03-B-13 for dioxane[1,4-]

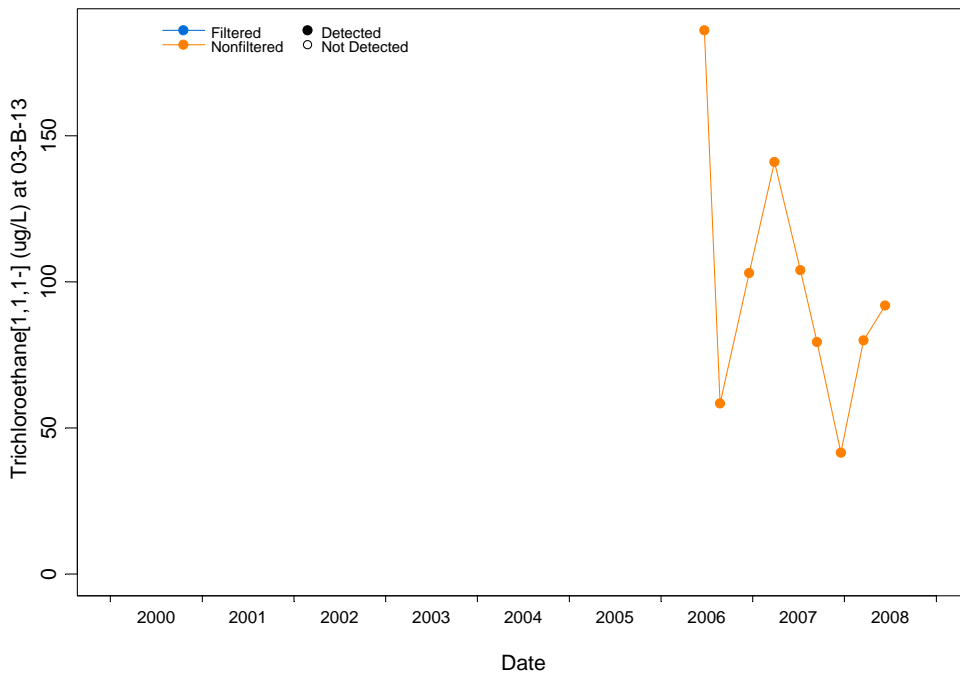

Figure D-2.2-74 Concentrations over time at 03-B-13 for trichloroethane[1,1,1-]

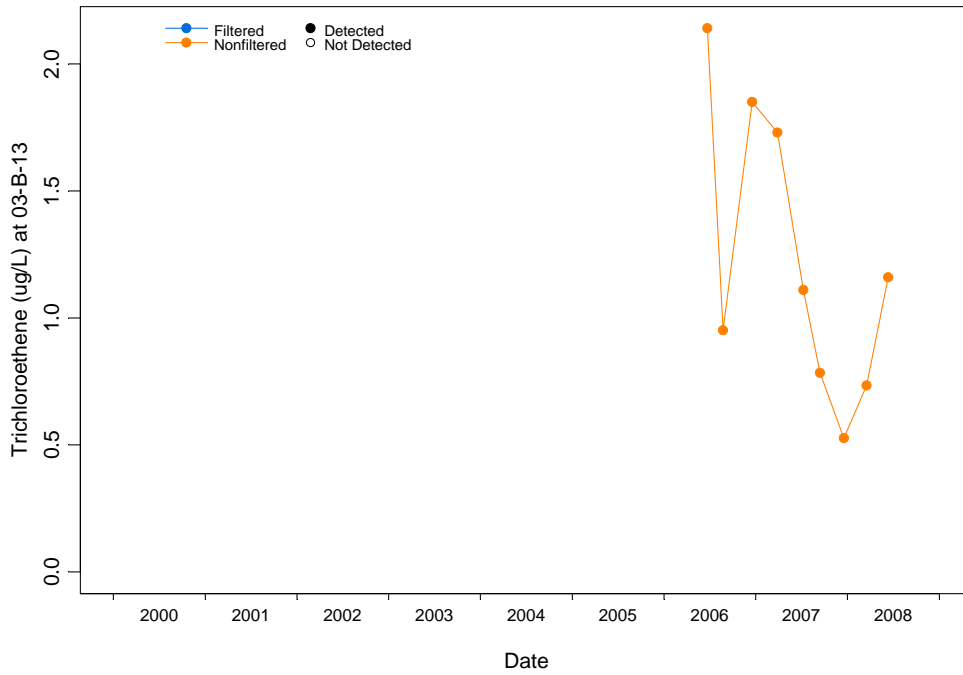

Figure D-2.2-75 Concentrations over time at 03-B-13 for trichloroethene

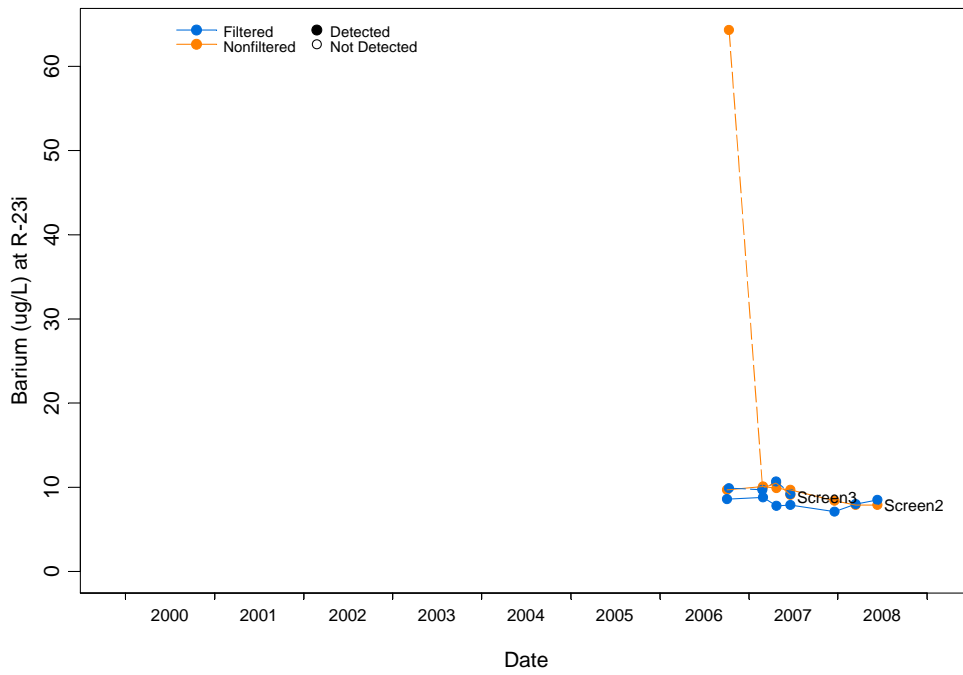

Figure D-2.2-76 Concentrations over time at R-23i for barium

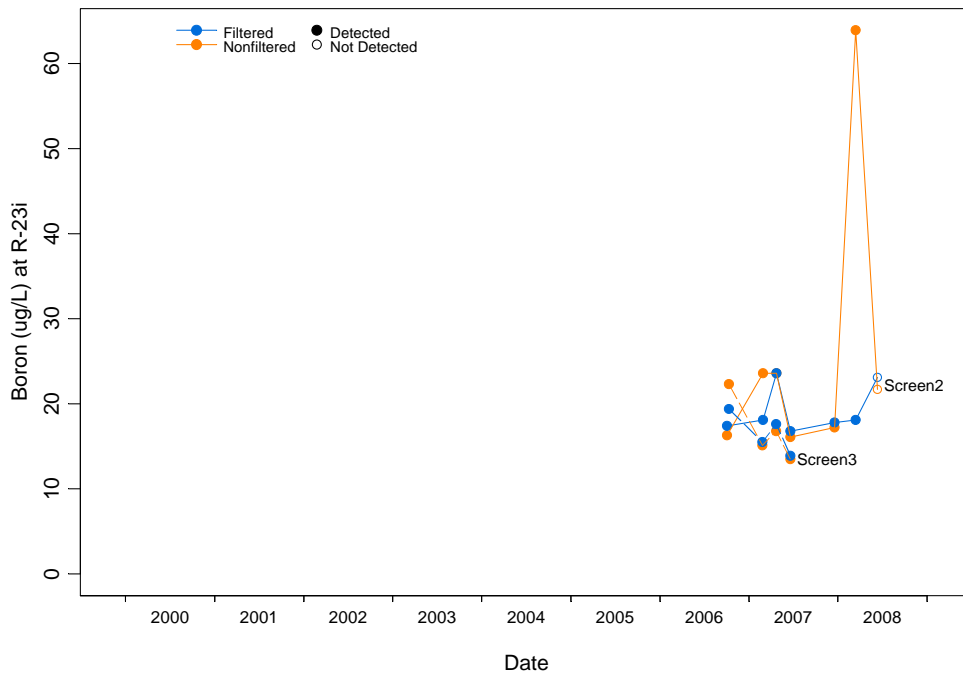

Figure D-2.2-77 Concentrations over time at R-23i for boron

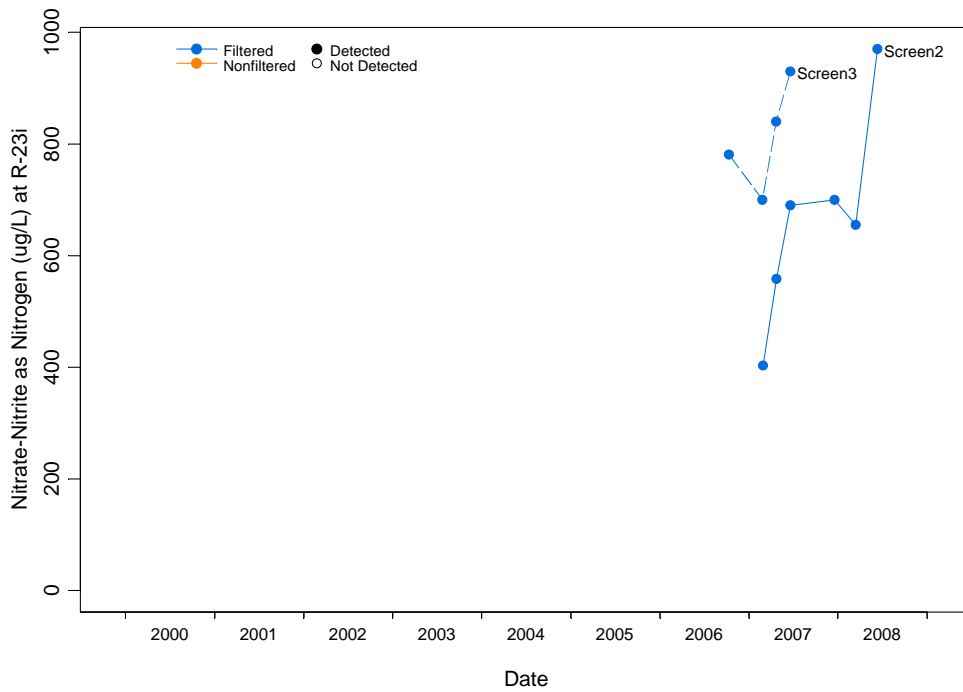

Figure D-2.2-78 Concentrations over time at R-23i for nitrate-nitrite as nitrogen

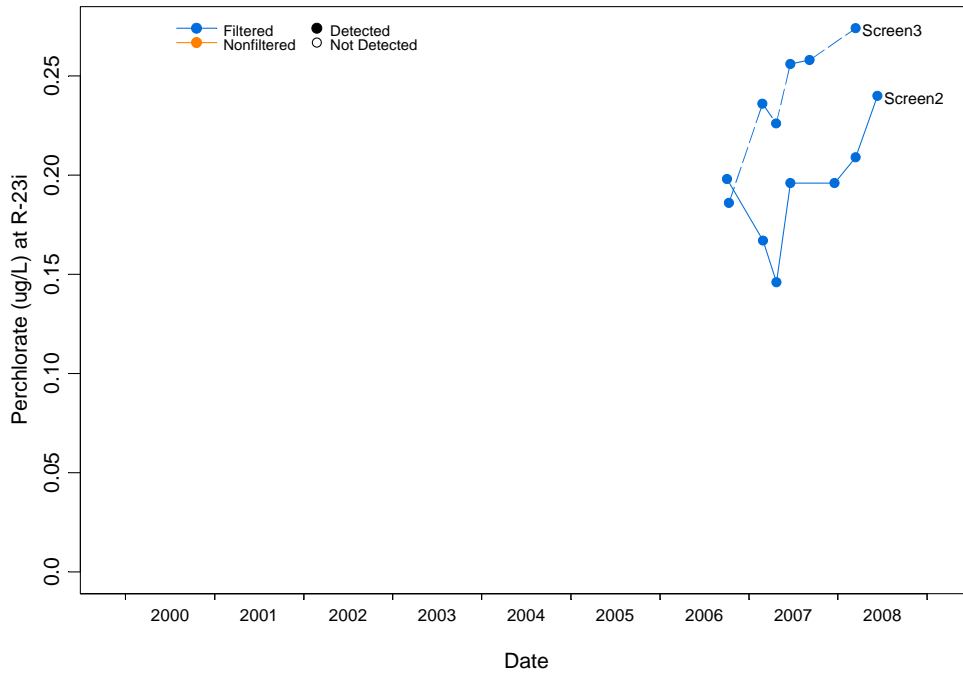

Figure D-2.2-79 Concentrations over time at R-23i for perchlorate

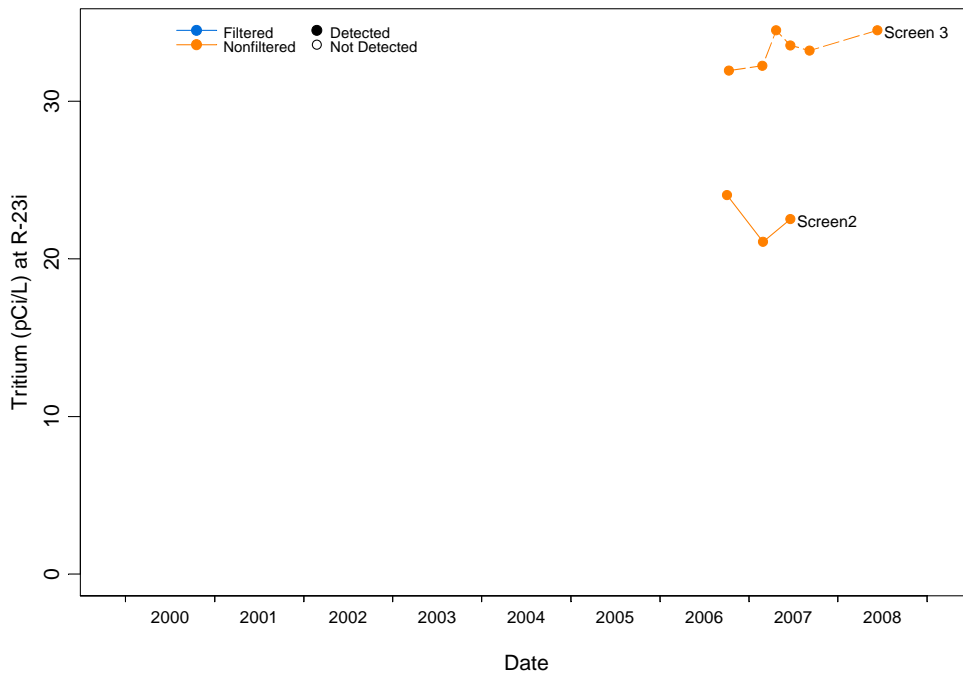

Figure D-2.2-80 Concentrations over time at R-23i for tritium at R-23i

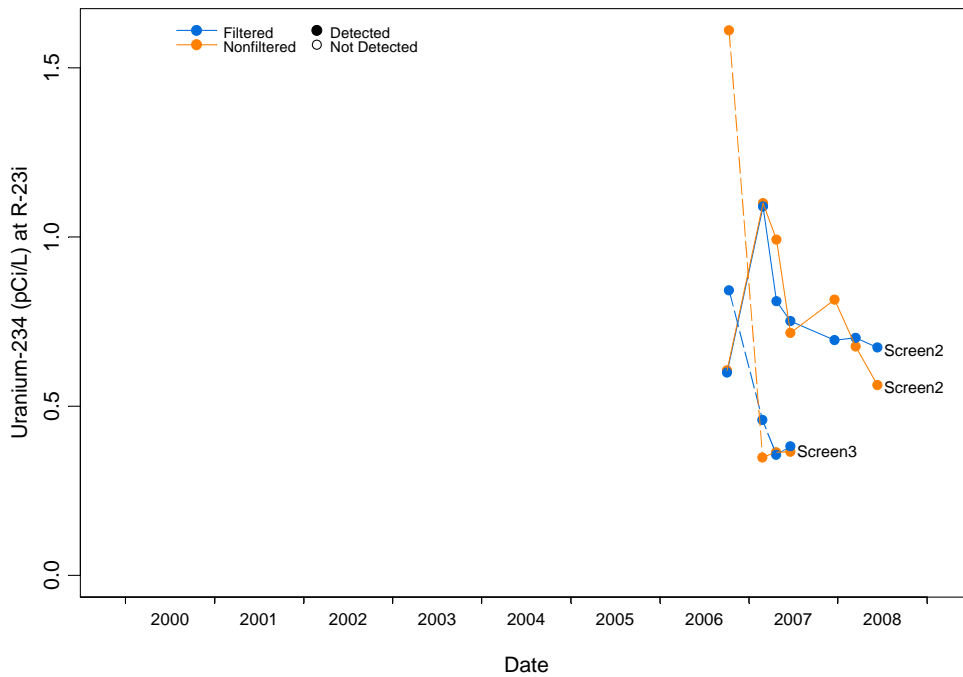

Figure D-2.2-81 Concentrations over time at R-23i for uranium-234

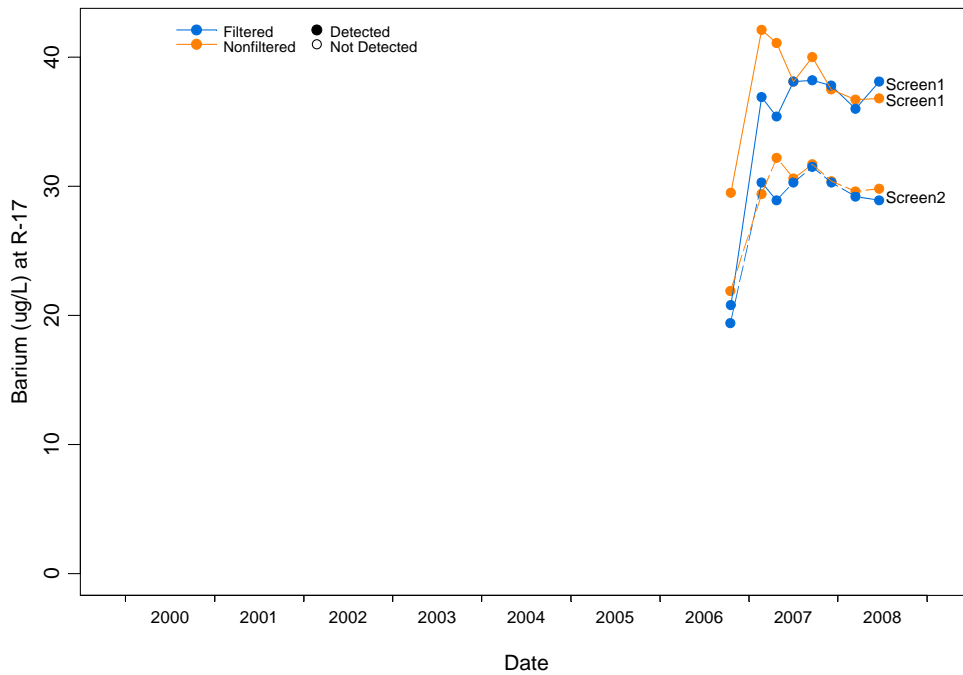

Figure D-2.2-82 Concentrations over time at R-17 for barium

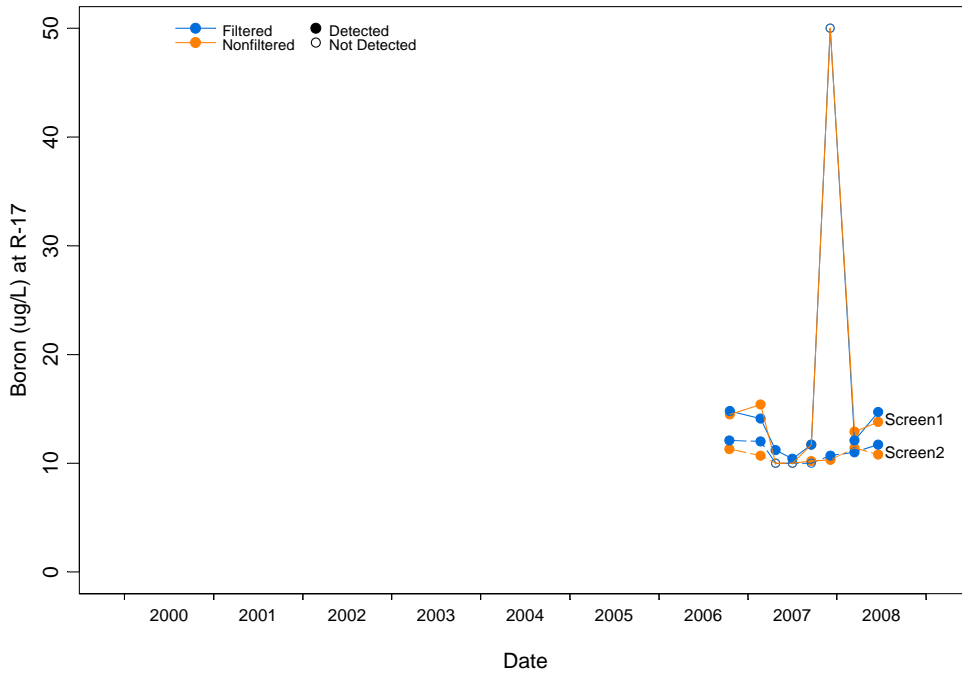

Figure D-2.2-83 Concentrations over time at R-17 for boron

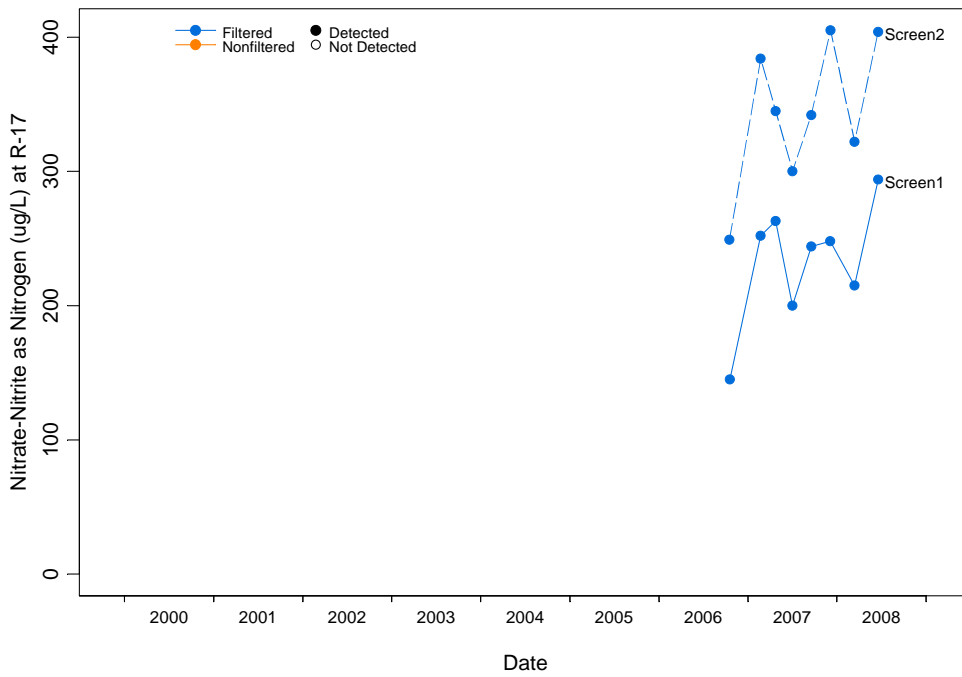

Figure D-2.2-84 Concentrations over time at R-17 for nitrate-nitrite as nitrogen

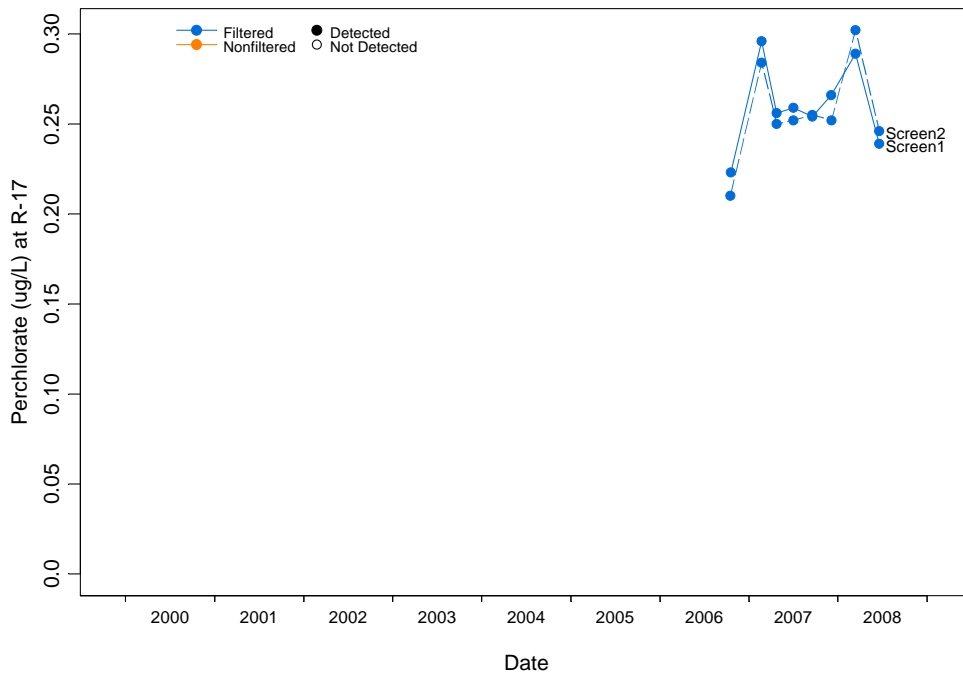

Figure D-2.2-85 Concentrations over time at R-17 for perchlorate

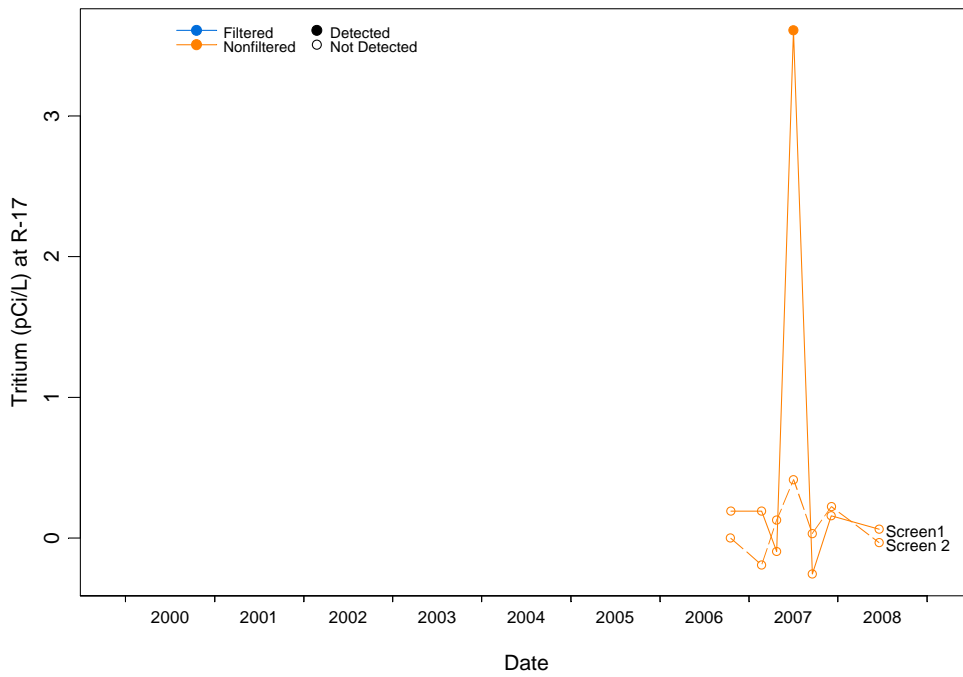

Figure D-2.2-86 Concentrations over time at R-17 for tritium

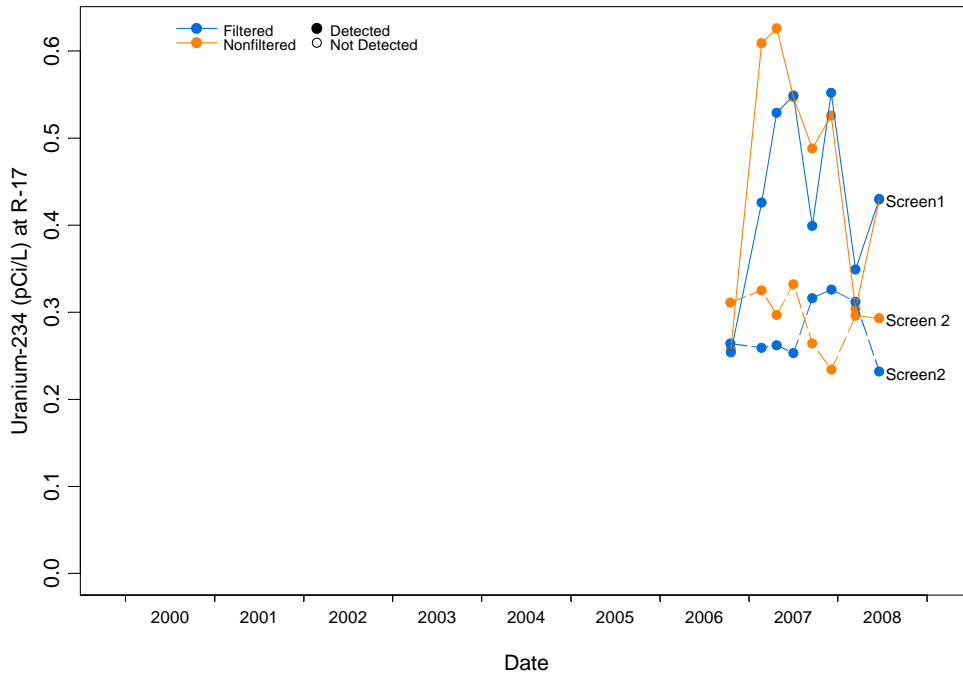

Figure D-2.2-87 Concentrations over time at R-17 for uranium-234

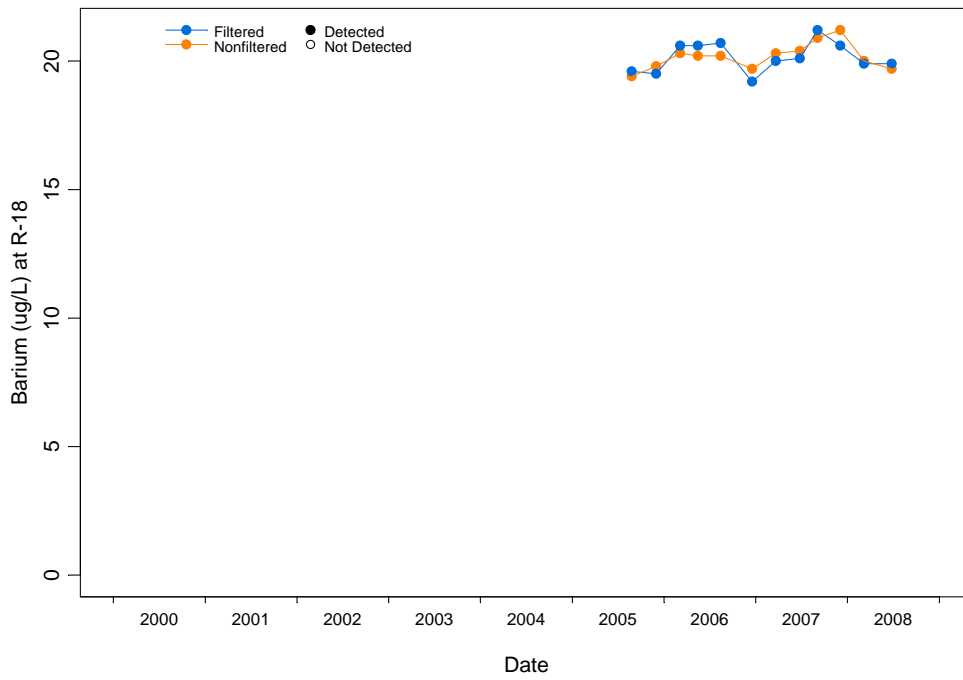

Figure D-2.2-88 Concentrations over time at R-18 for barium

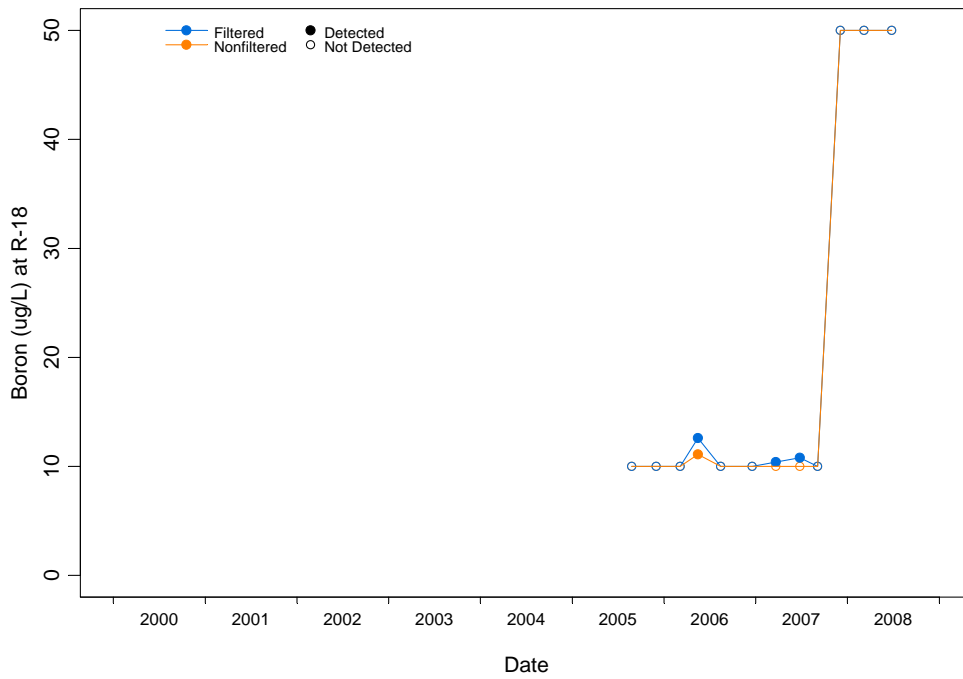

Figure D-2.2-89 Concentrations over time at R-18 for boron

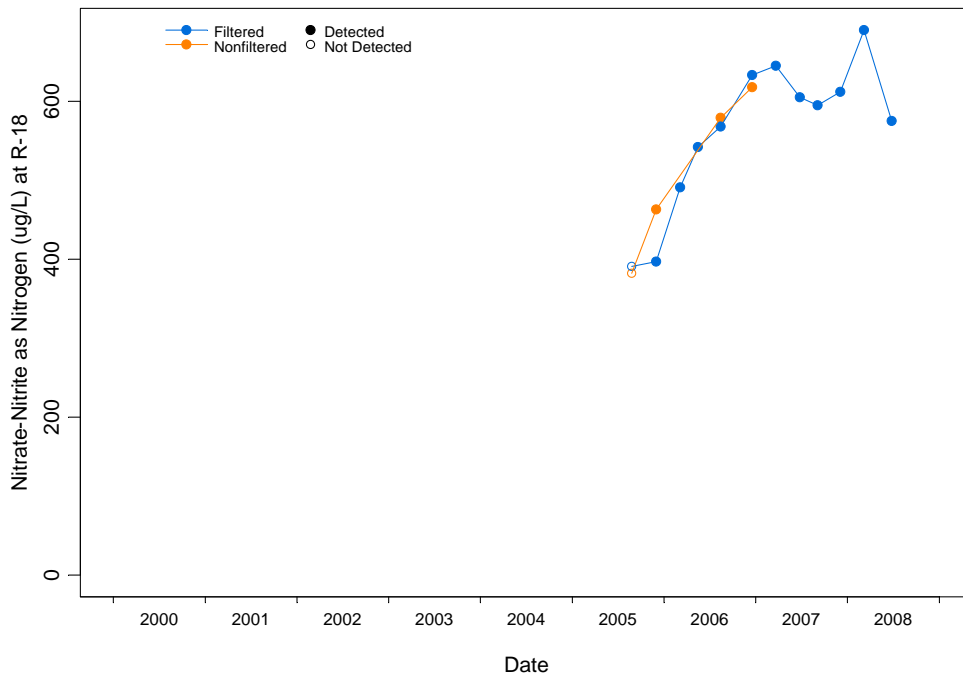

Figure D-2.2-90 Concentrations over time at R-18 for nitrate-nitrite as nitrogen

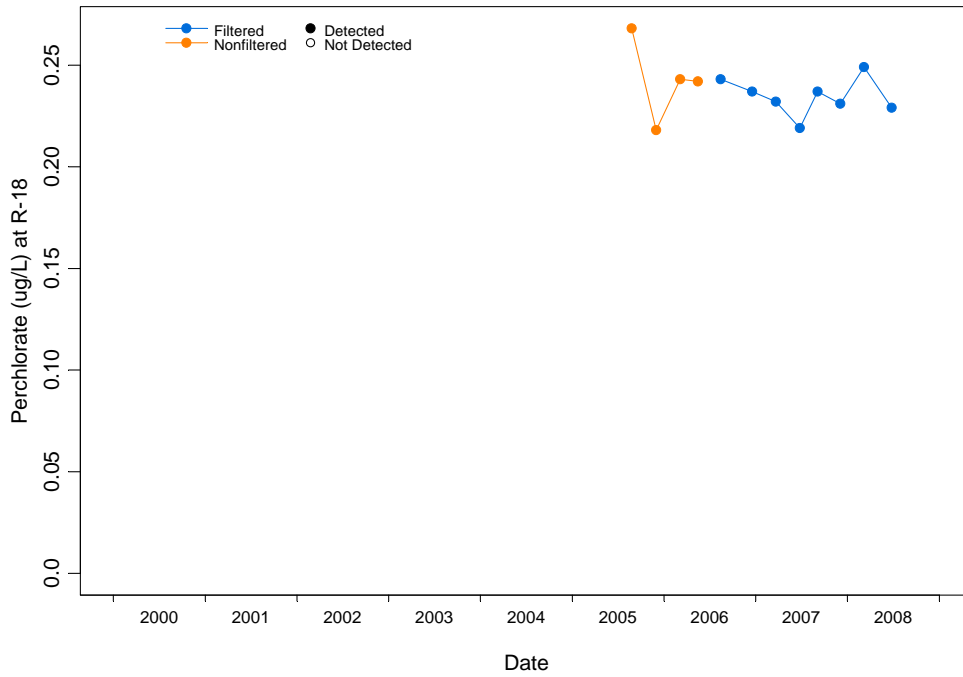

Figure D-2.2-91 Concentrations over time at R-18 for perchlorate

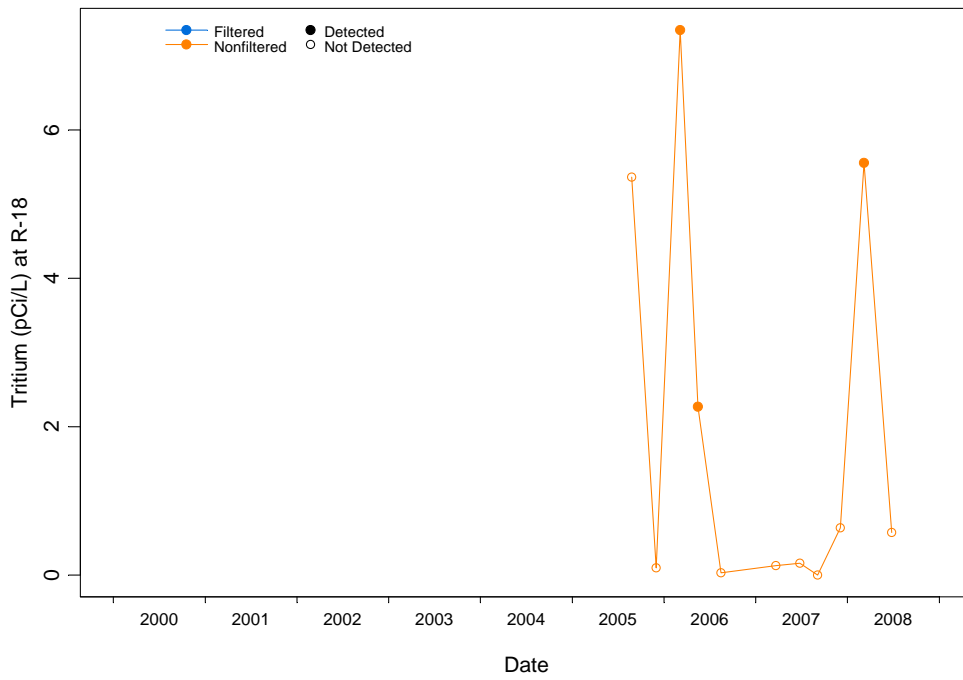

Figure D-2.2-92 Concentrations over time at R-18 for tritium

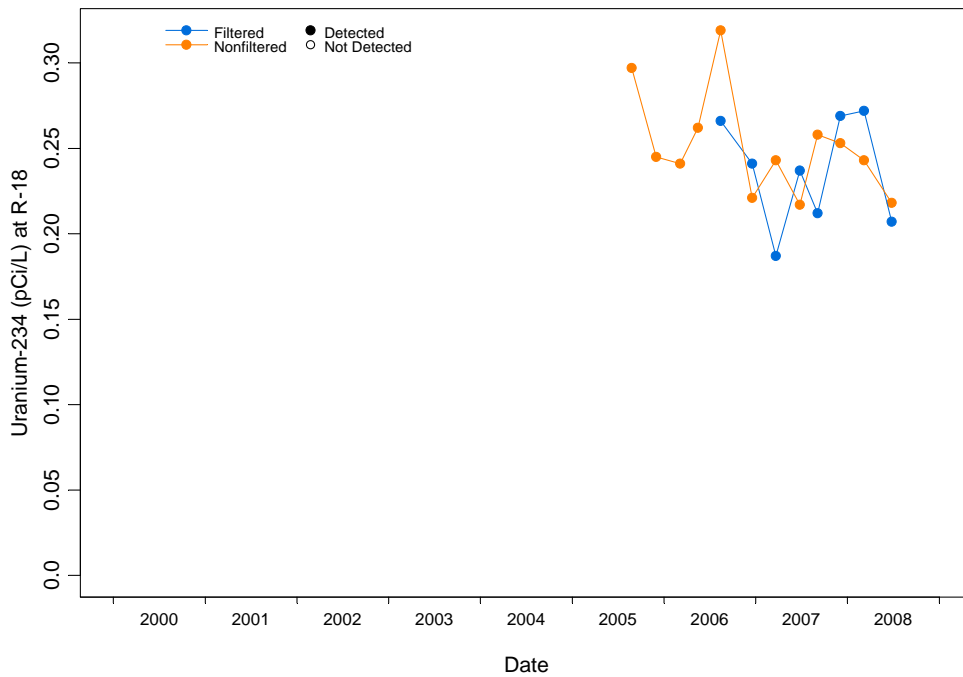

Figure D-2.2-93 Concentrations over time at R-18 for uranium-234

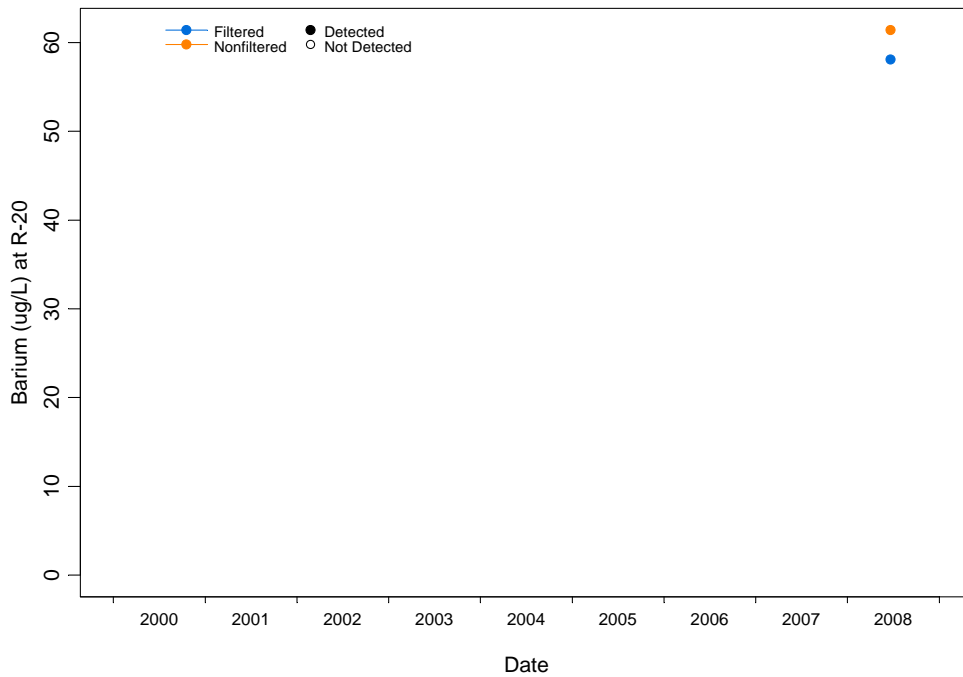

Figure D-2.2-94 Concentrations over time at R-20 for barium (post-well rehabilitation)

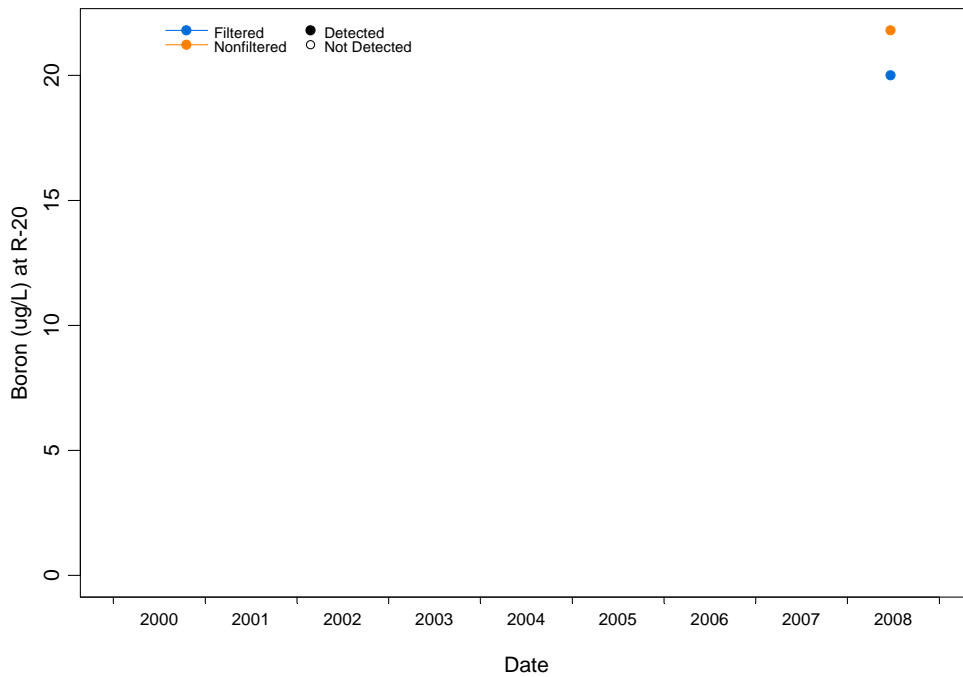

Figure D-2.2-95 Concentrations over time at R-20 for boron (post-well rehabilitation)

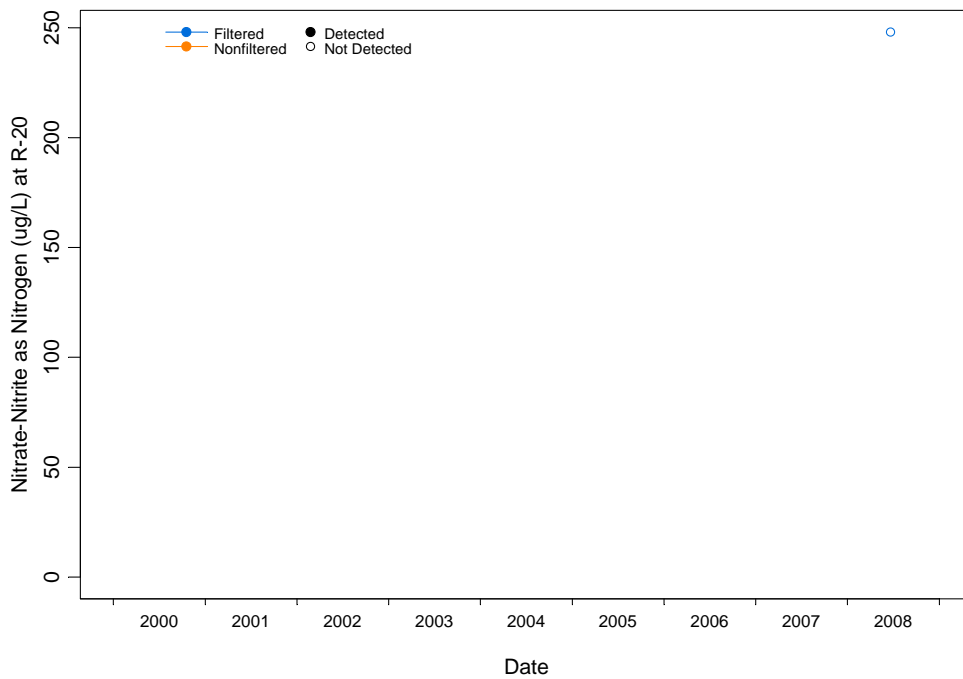

Figure D-2.2-96 Concentrations over time at R-20 for nitrate-nitrite as nitrogen (post-well rehabilitation)

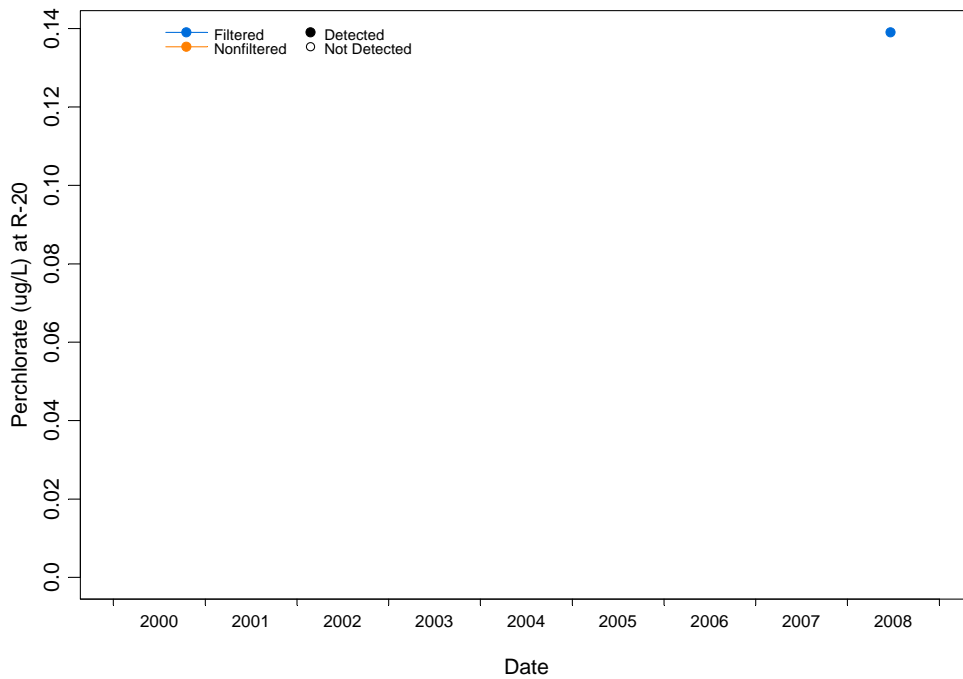

Figure D-2.2-97 Concentrations over time at R-20 for perchlorate (post-well rehabilitation)

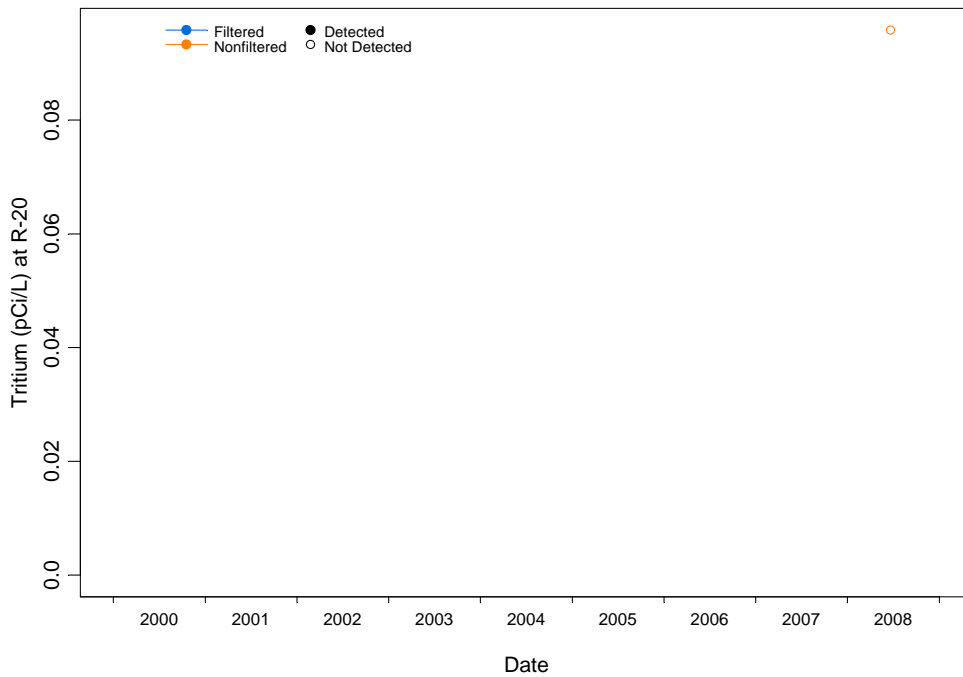

Figure D-2.2-98 Concentrations over time at R-20 for tritium (post-well rehabilitation)

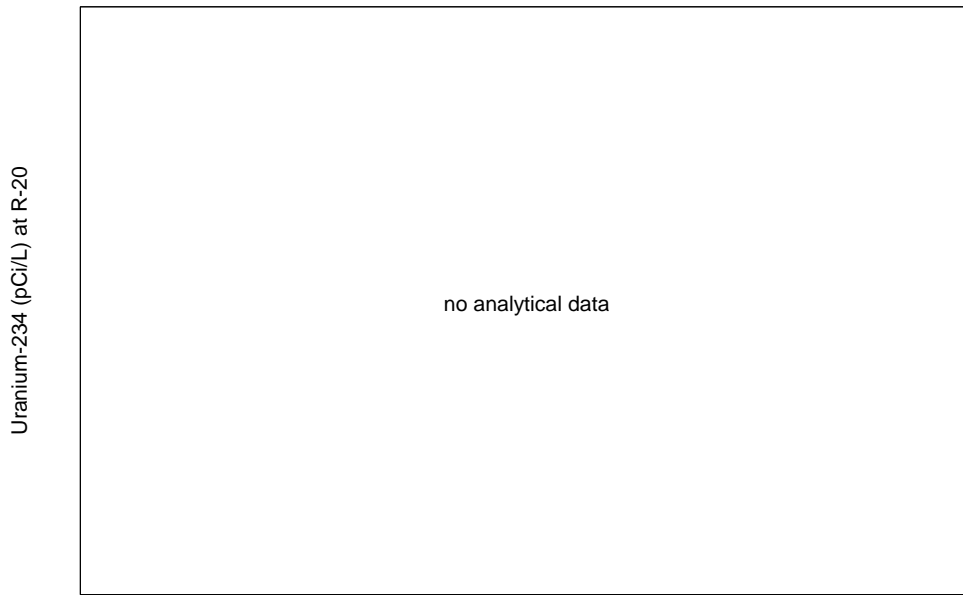

Figure D-2.2-99 Concentrations over time at R-20 for uranium-234—No analytical data

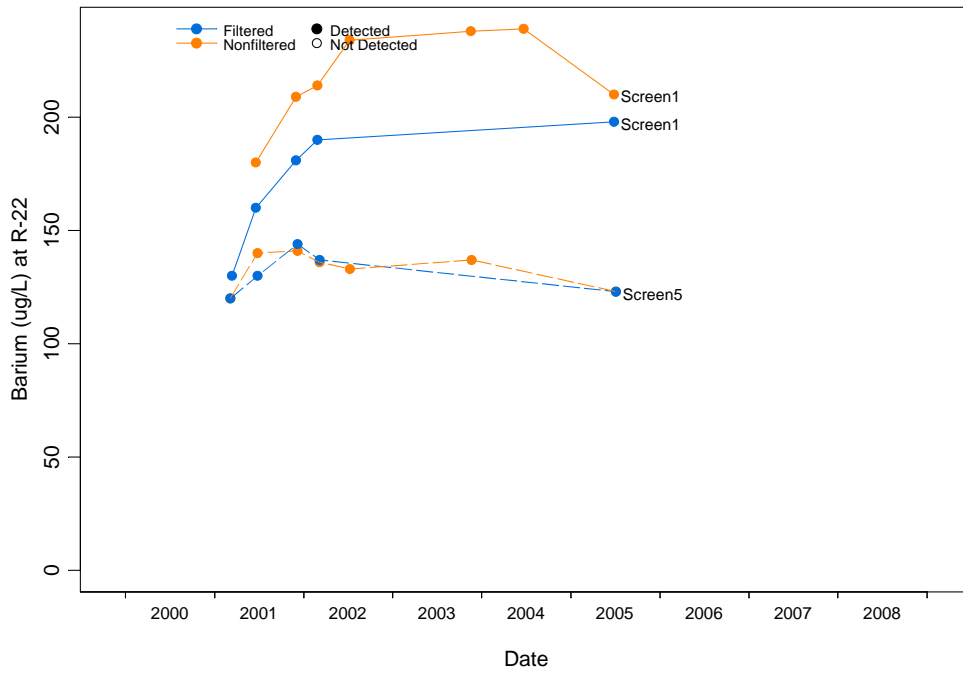

Figure D-2.2-100 Concentrations over time at R-22 for barium

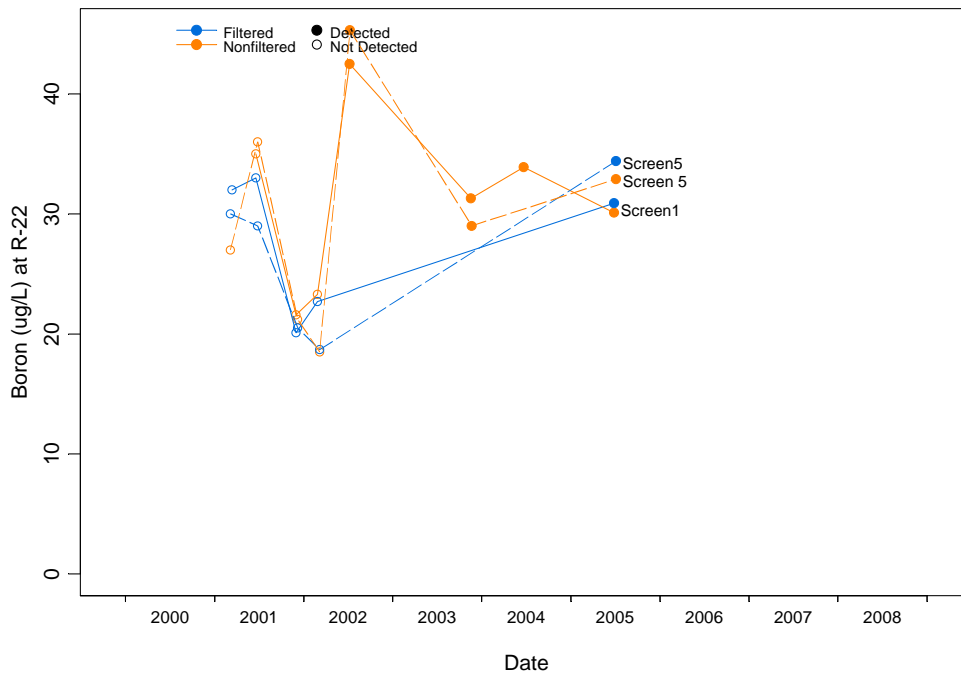

Figure D-2.2-101 Concentrations over time at R-22 for boron

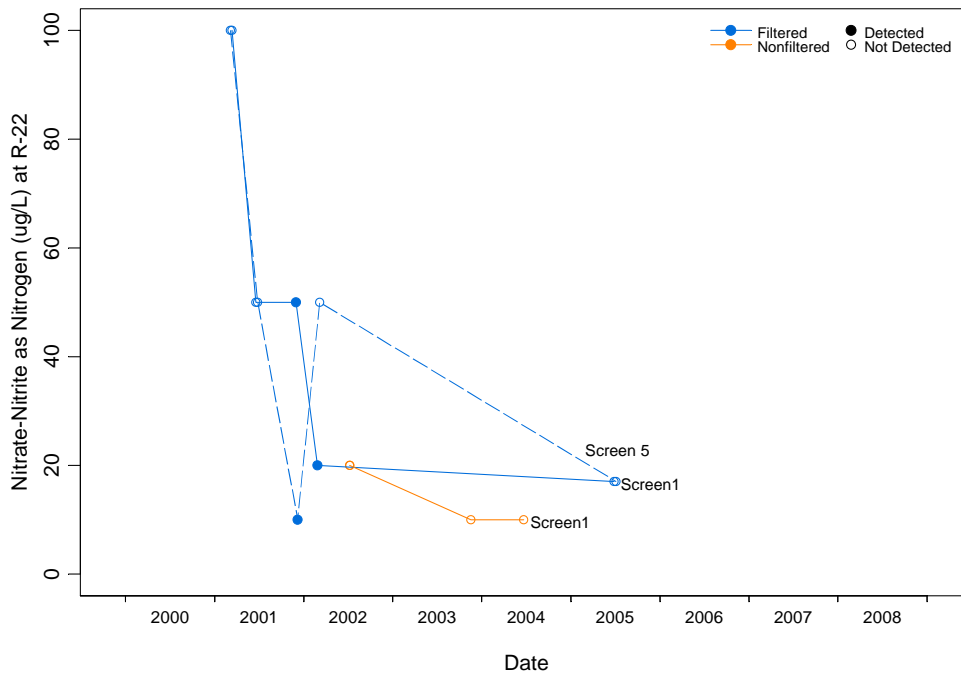

Figure D-2.2-102 Concentrations over time at R-22 for nitrate-nitrite as nitrogen

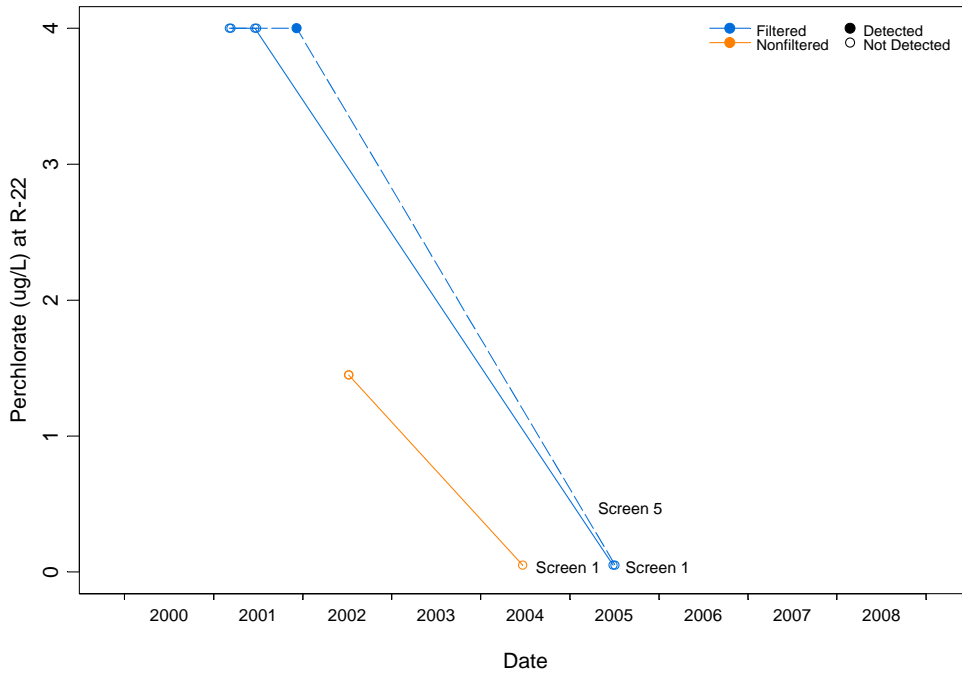

Figure D-2.2-103 Concentrations over time at R-22 for Perchlorate—analytical method before 2004 is EPA:314, analytical method post-2003 is SW-846:6850

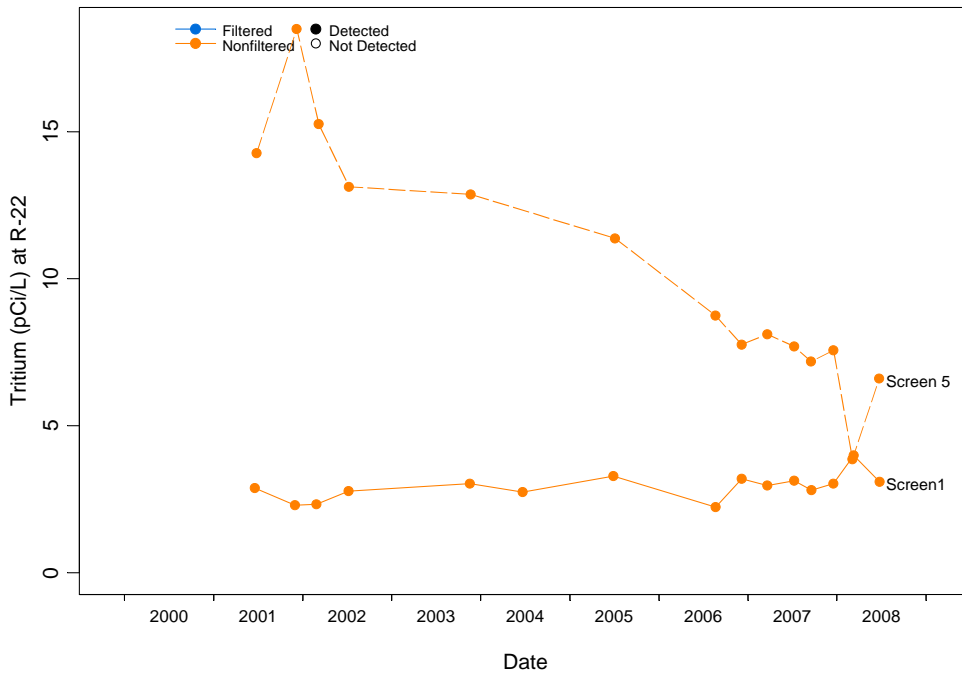

Figure D-2.2-104 Concentrations over time at R-22 for tritium

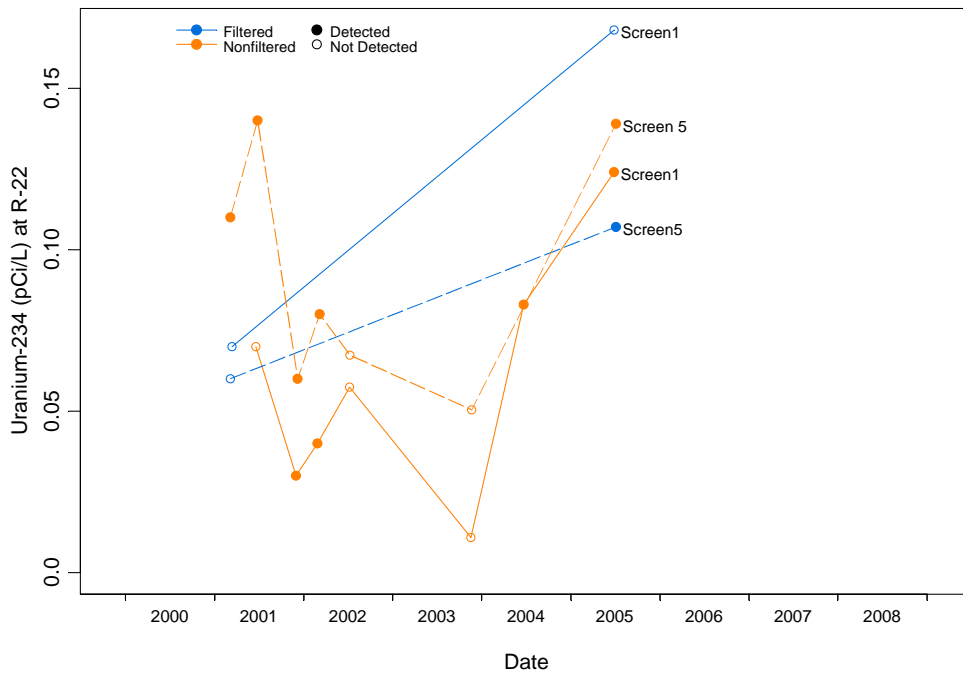

Figure D-2.2-105 Concentrations over time at R-22 for uranium-234

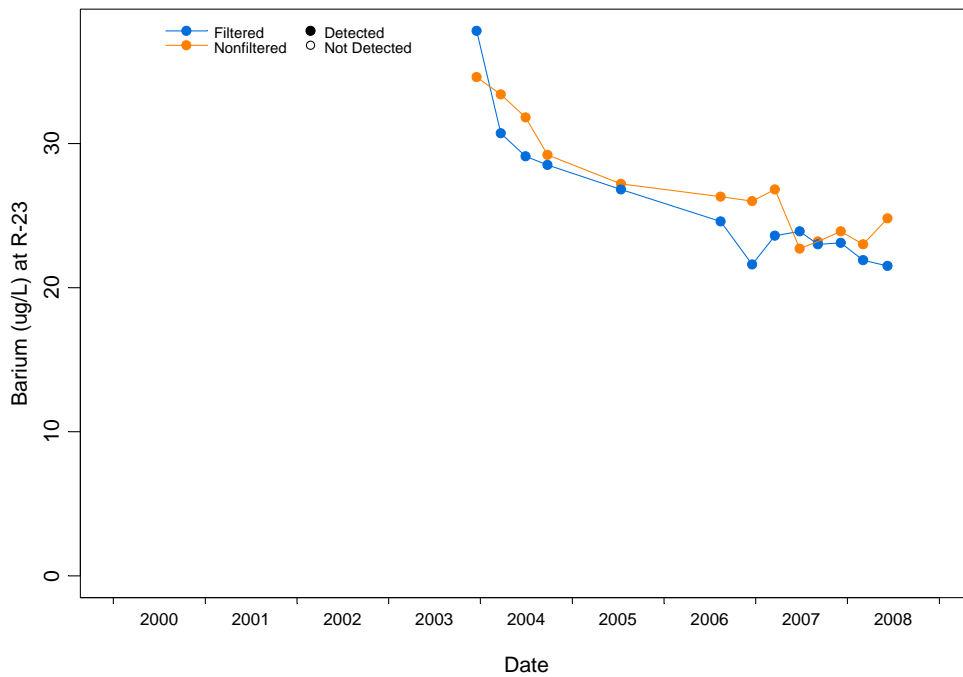

Figure D-2.2-106 Concentrations over time at R-23 for barium

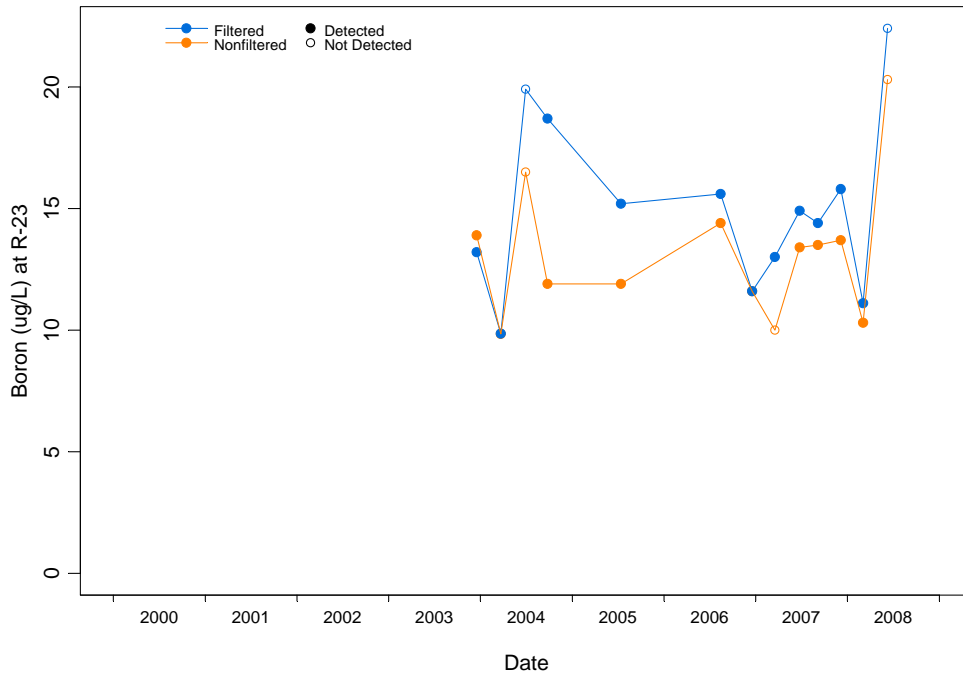

Figure D-2.2-107 Concentrations over time at R-23 for boron

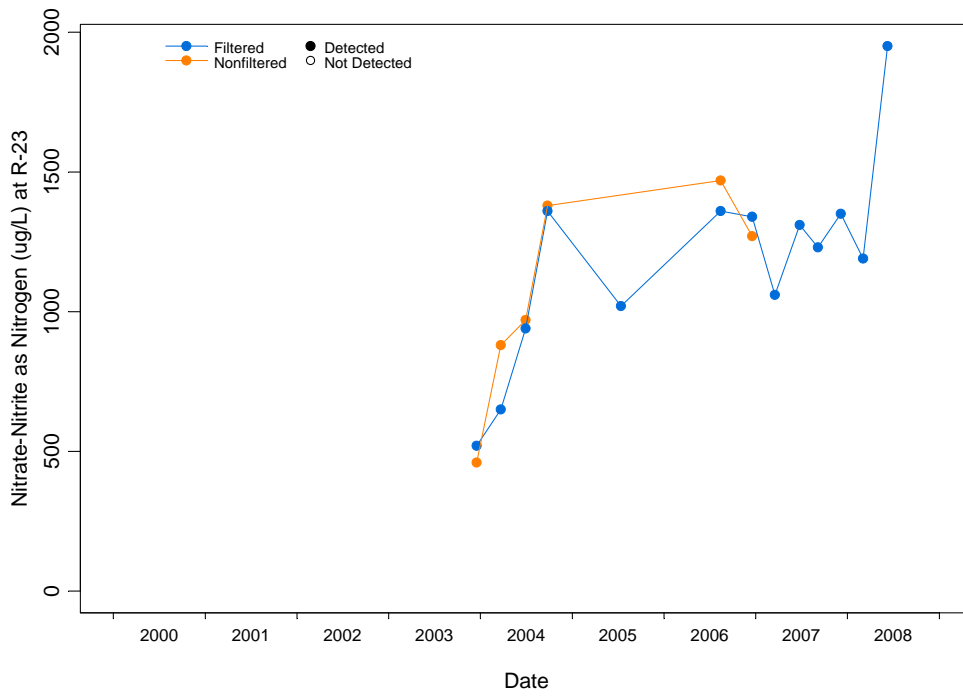

Figure D-2.2-108 Concentrations over time at R-23 for nitrate-nitrite as nitrogen

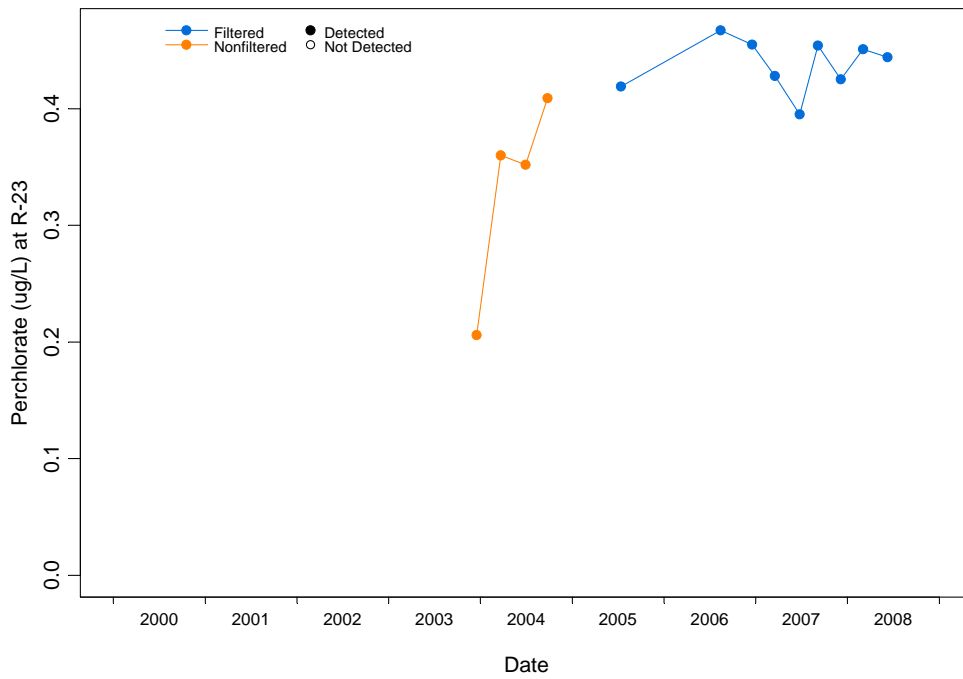

Figure D-2.2-109 Concentrations over time at R-23 for perchlorate

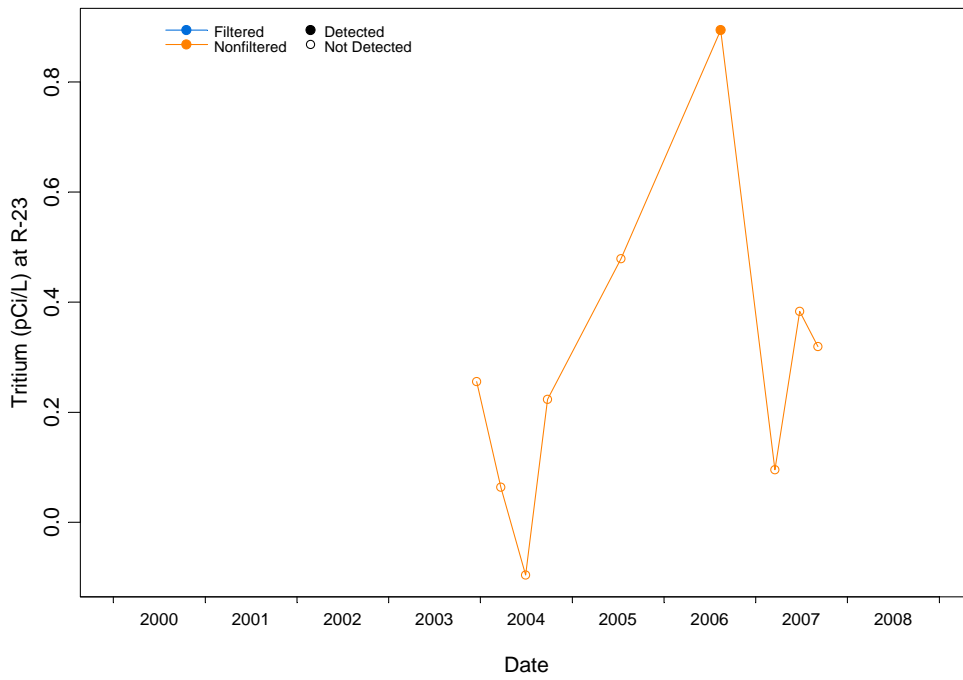

Figure D-2.2-110 Concentrations over time at R-23 for tritium

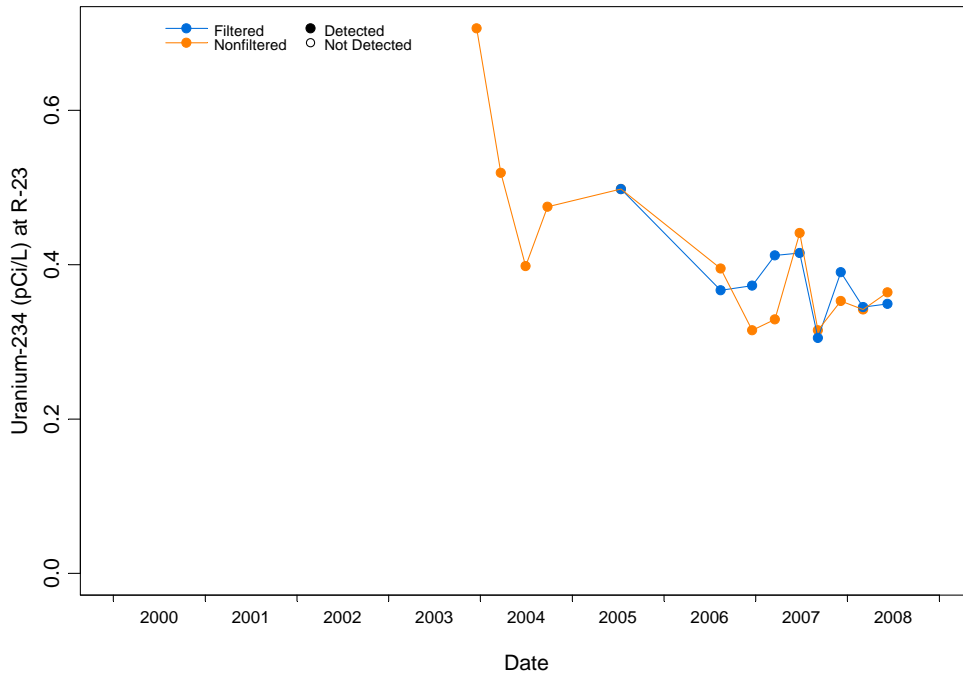

Figure D-2.2-111 Concentrations over time at R-23 for uranium-234

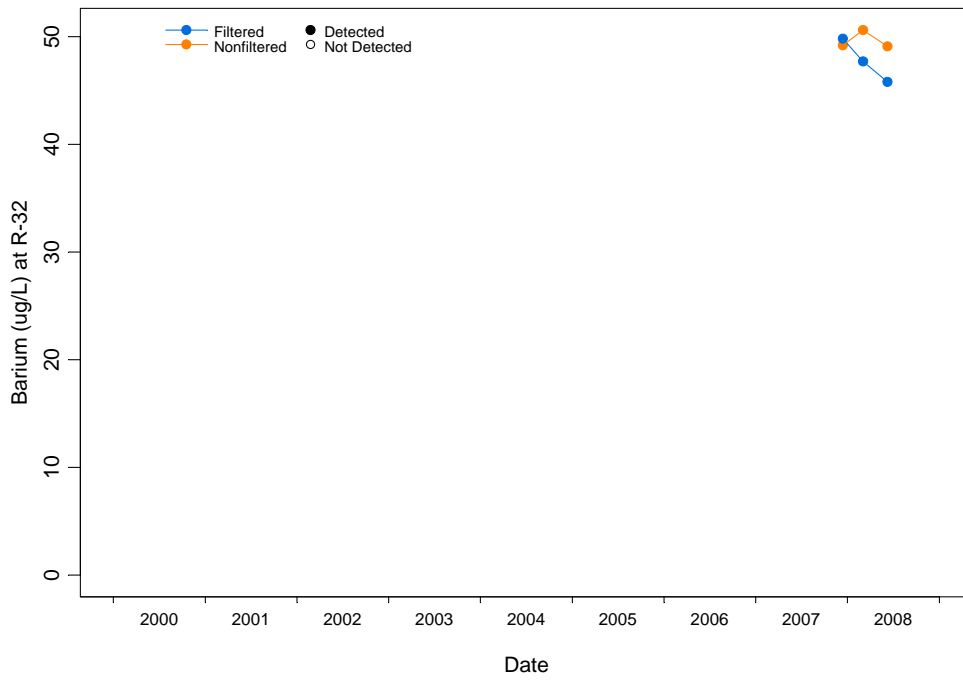

Figure D-2.2-112 Concentrations over time at R-32 for barium (post-well rehabilitation)

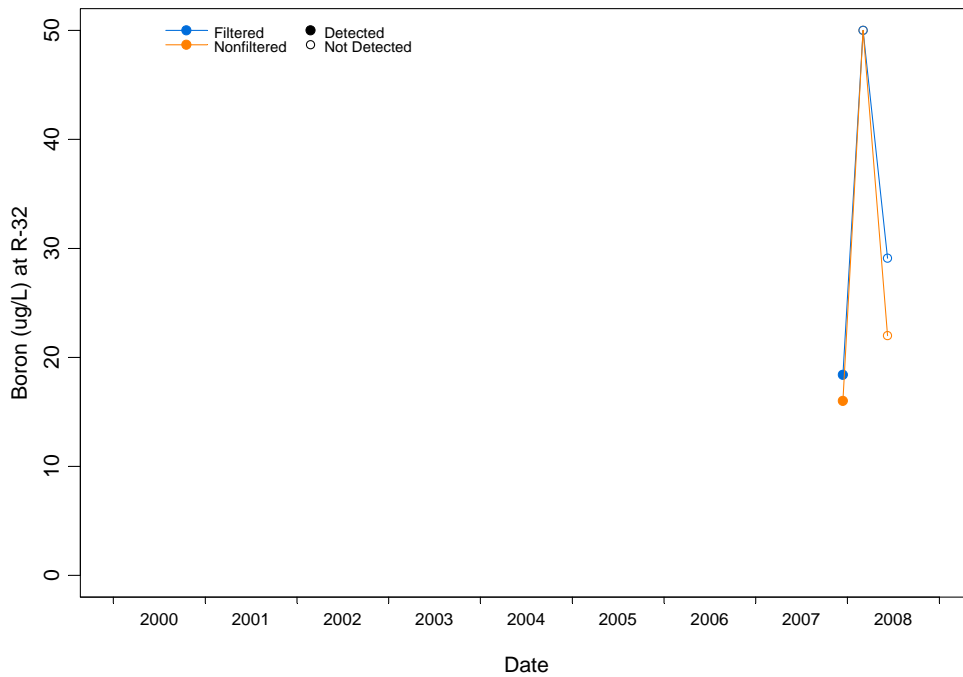

Figure D-2.2-113 Concentrations over time at R-32 for boron (post-well rehabilitation)

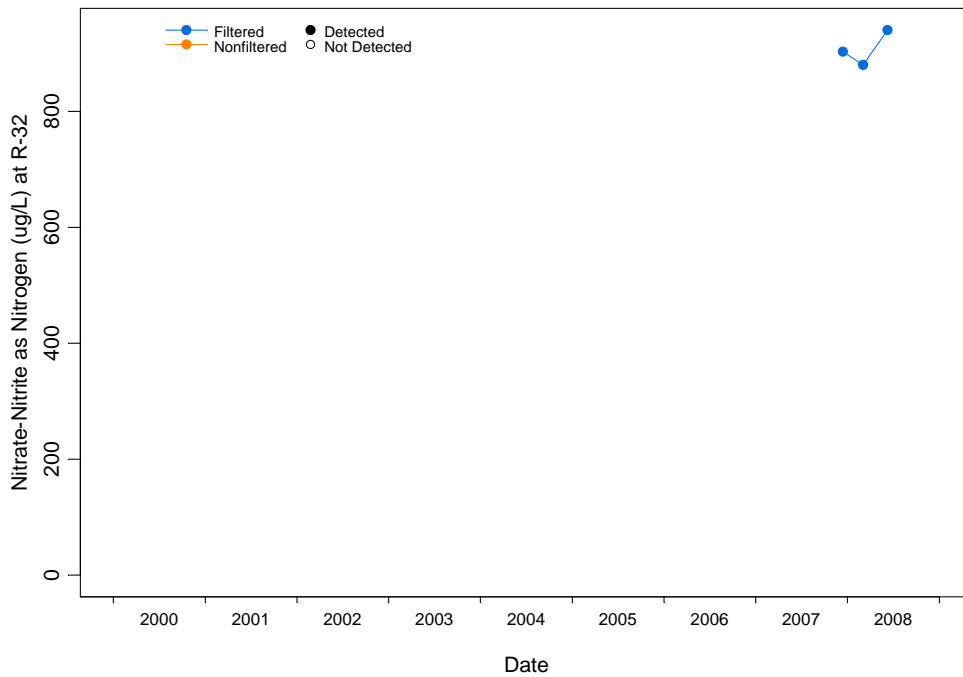

Figure D-2.2-114 Concentrations over time at R-32 for nitrate-nitrite as nitrogen (post-well rehabilitation)

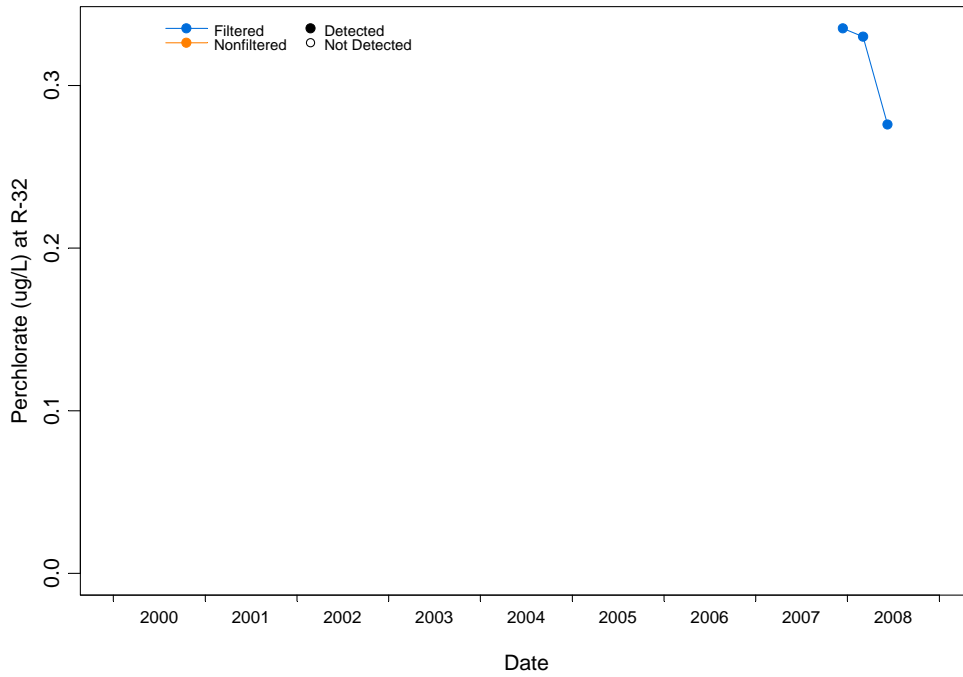

Figure D-2.2-115 Concentrations over time at R-32 for perchlorate (post-well rehabilitation)

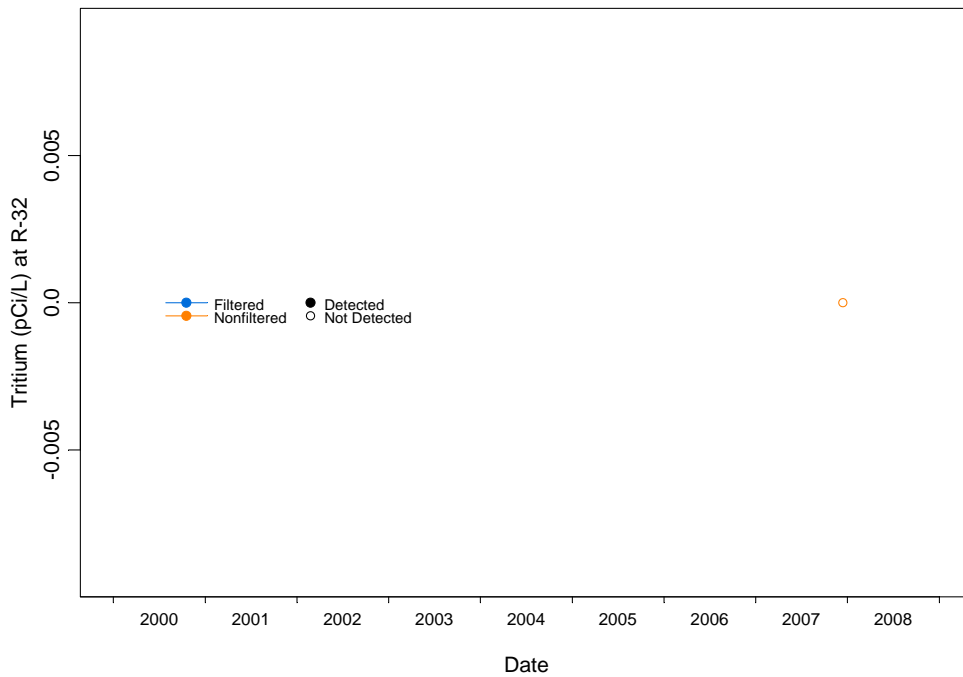

Figure D-2.2-116 Concentrations over time at R-32 for tritium (post-well rehabilitation)

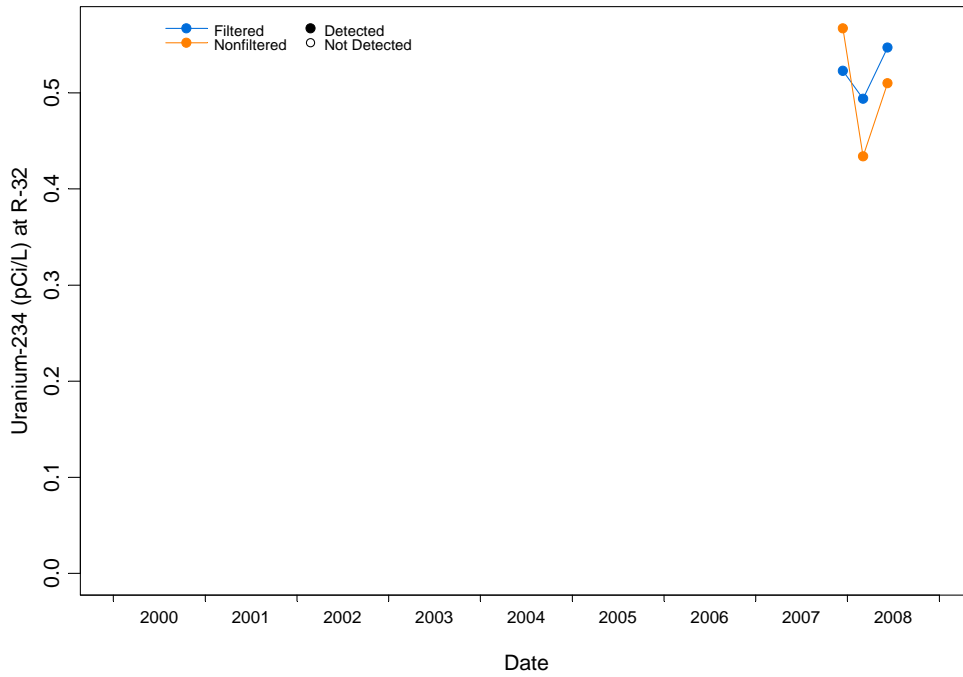

Figure D-2.2-117 Concentrations over time at R-32 for uranium-234 (post-well rehabilitation)

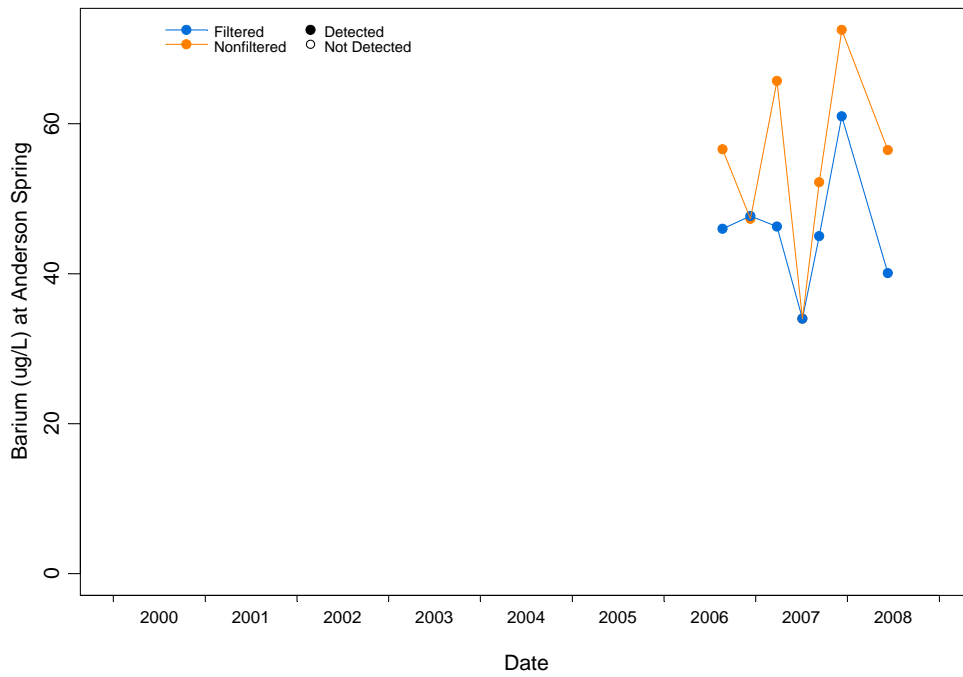

Figure D-2.2-118 Concentrations over time at Anderson Spring for barium

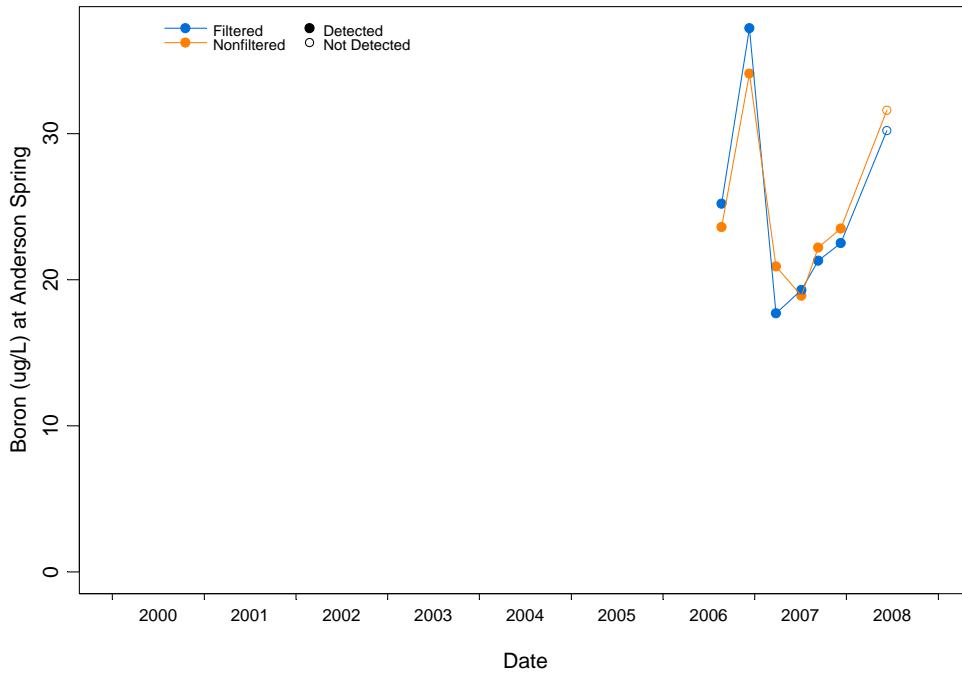

Figure D-2.2-119 Concentrations over time at Anderson Spring for boron

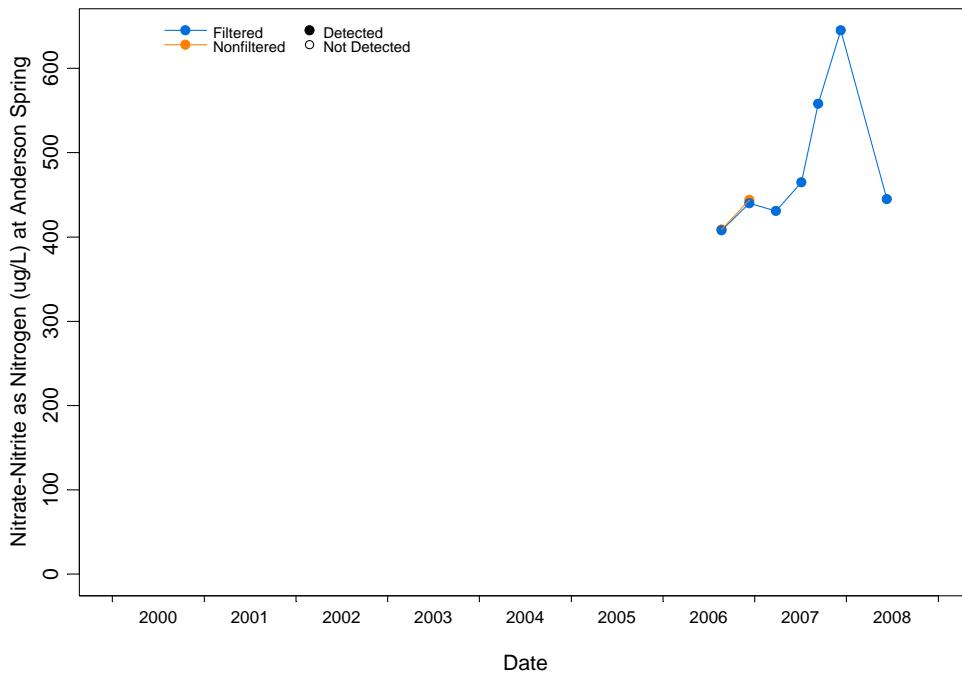

Figure D-2.2-120 Concentrations over time at Anderson Spring for nitrate-nitrite as nitrogen

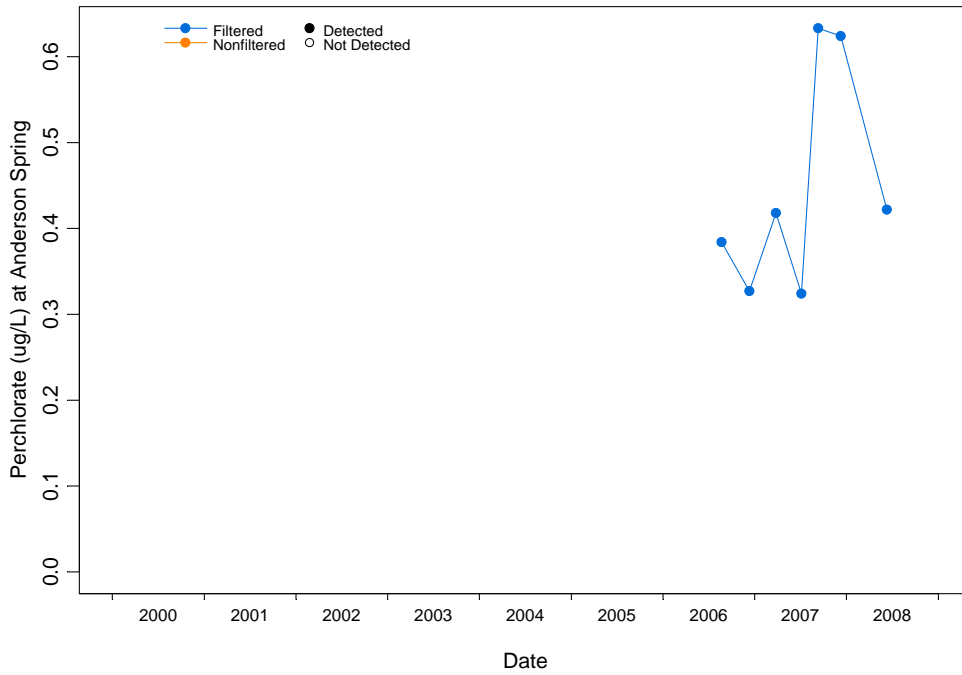

Figure D-2.2-121 Concentrations over time at Anderson Spring for perchlorate

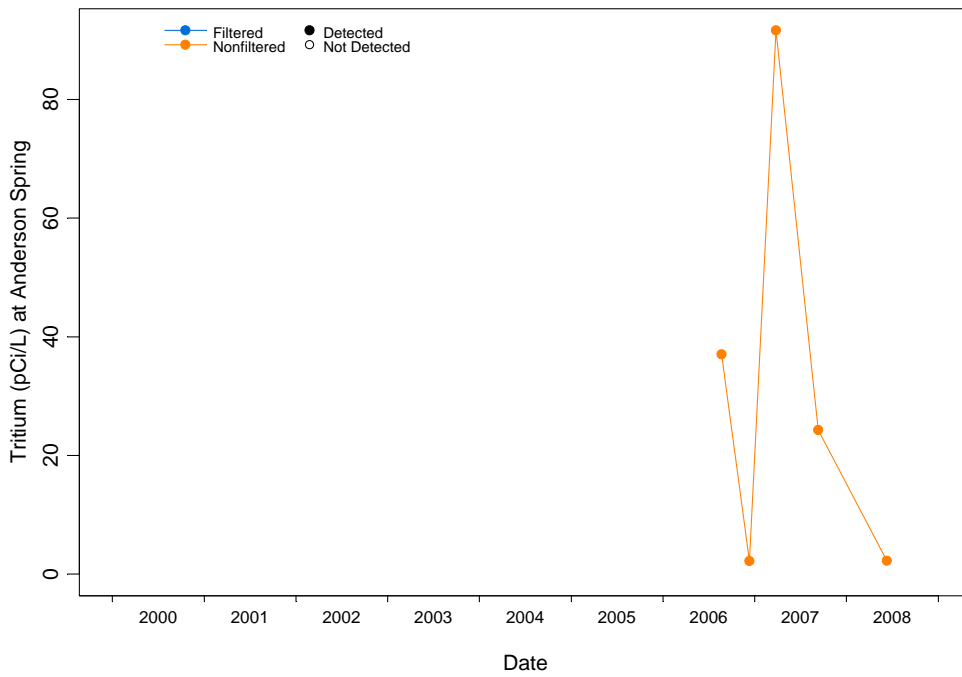

Figure D-2.2-122 Concentrations over time at Anderson Spring for tritium

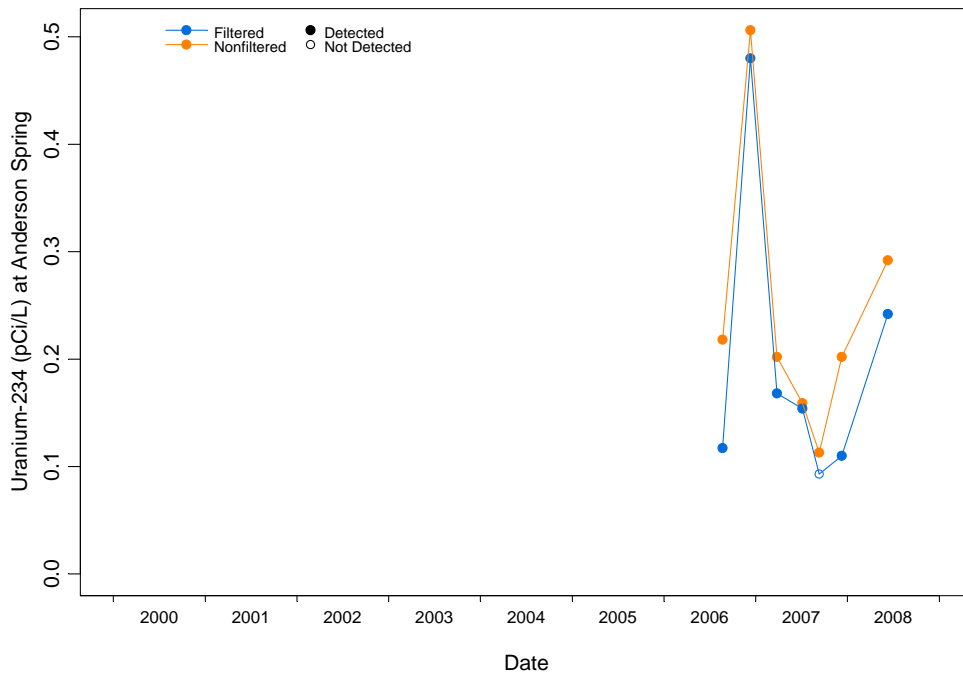

Figure D-2.2-123 Concentrations over time at Anderson Spring for uranium-234

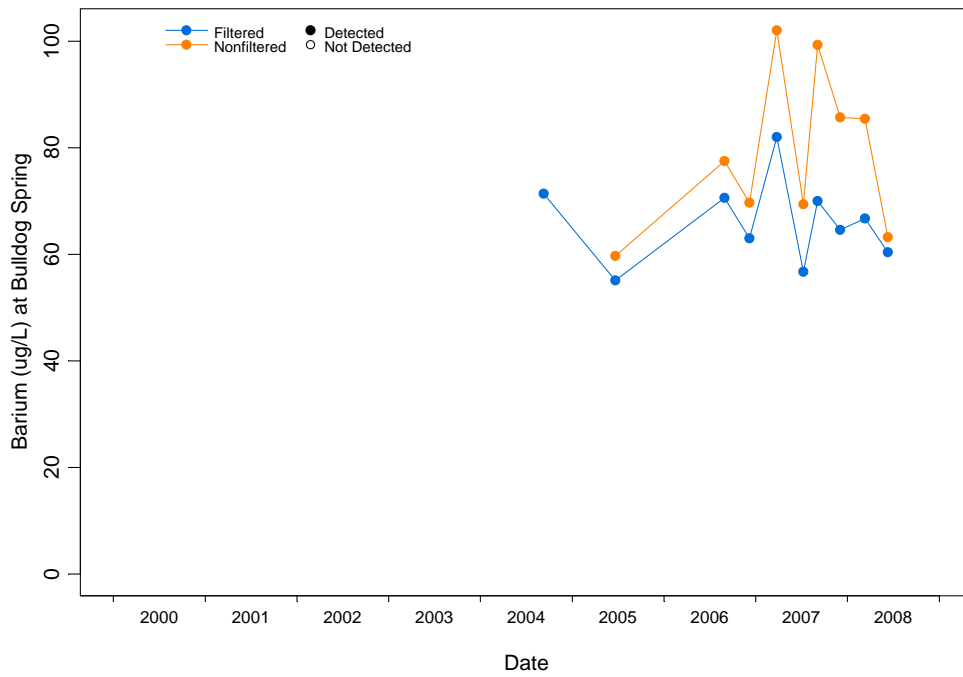

Figure D-2.2-124 Concentrations over time at Bulldog Spring for barium

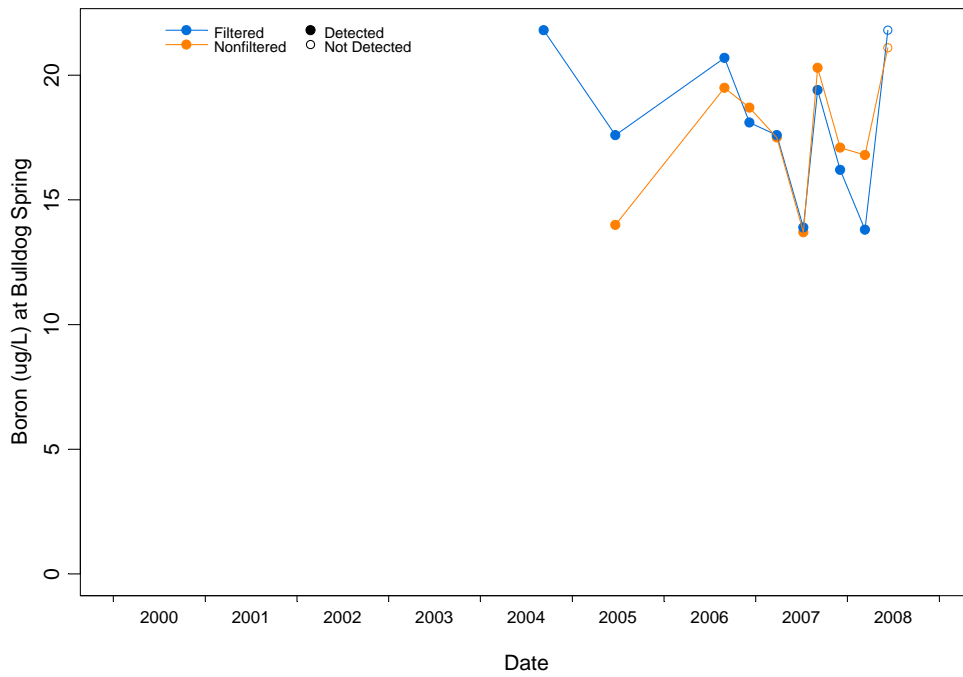

Figure D-2.2-125 Concentrations over time at Bulldog Spring for boron

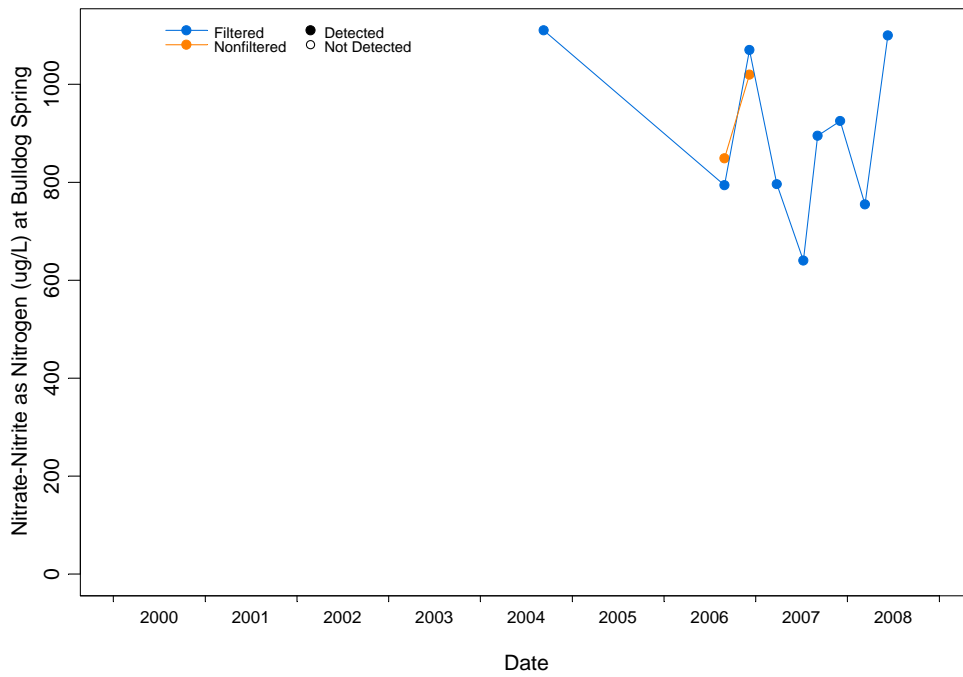

Figure D-2.2-126 Concentrations over time at Bulldog Spring for nitrate-nitrite as nitrogen

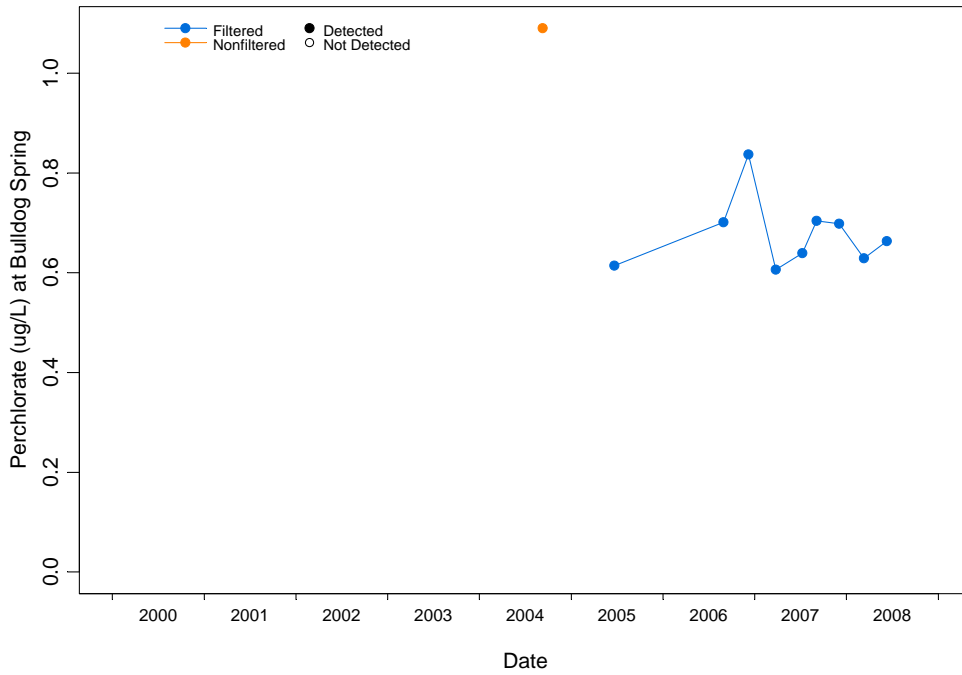

Figure D-2.2-127 Concentrations over time at Bulldog Spring for perchlorate

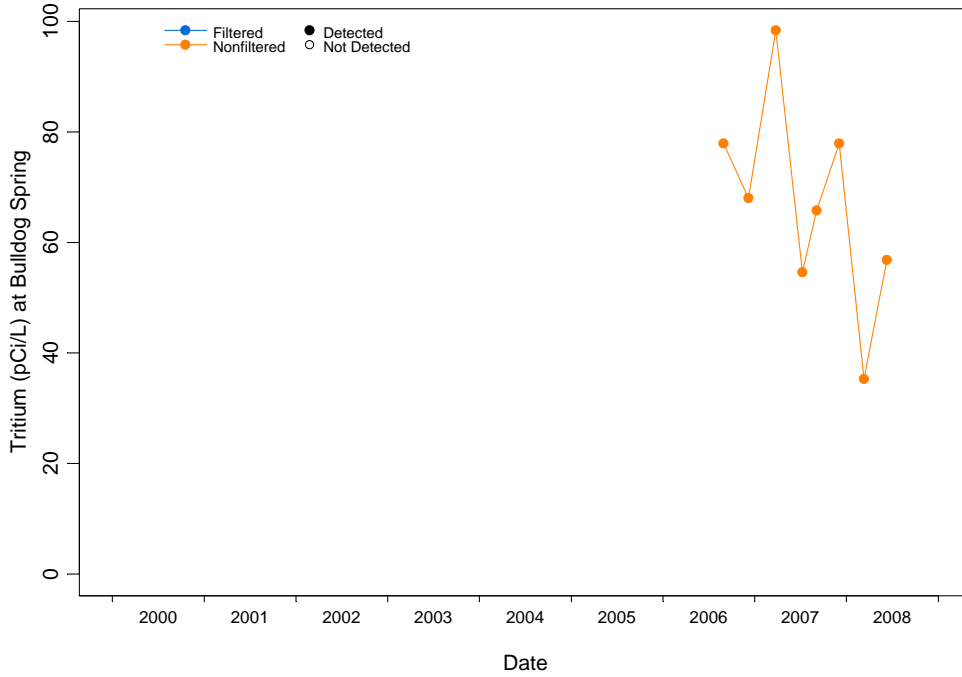

Figure D-2.2-128 Concentrations over time at Bulldog Spring for tritium

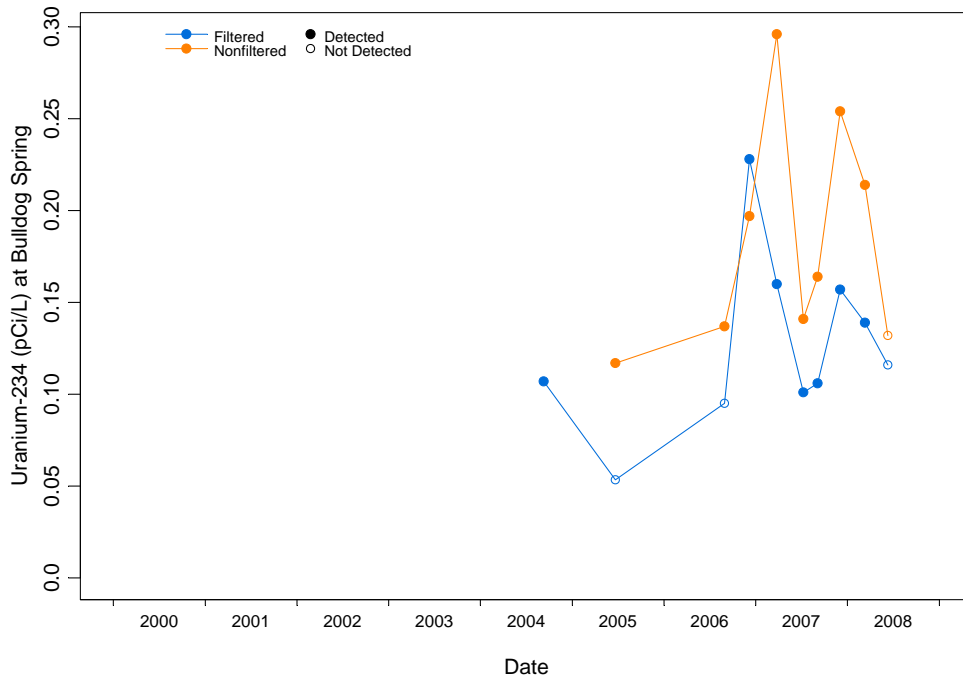

Figure D-2.2-129 Concentrations over time at Bulldog Spring for uranium-234

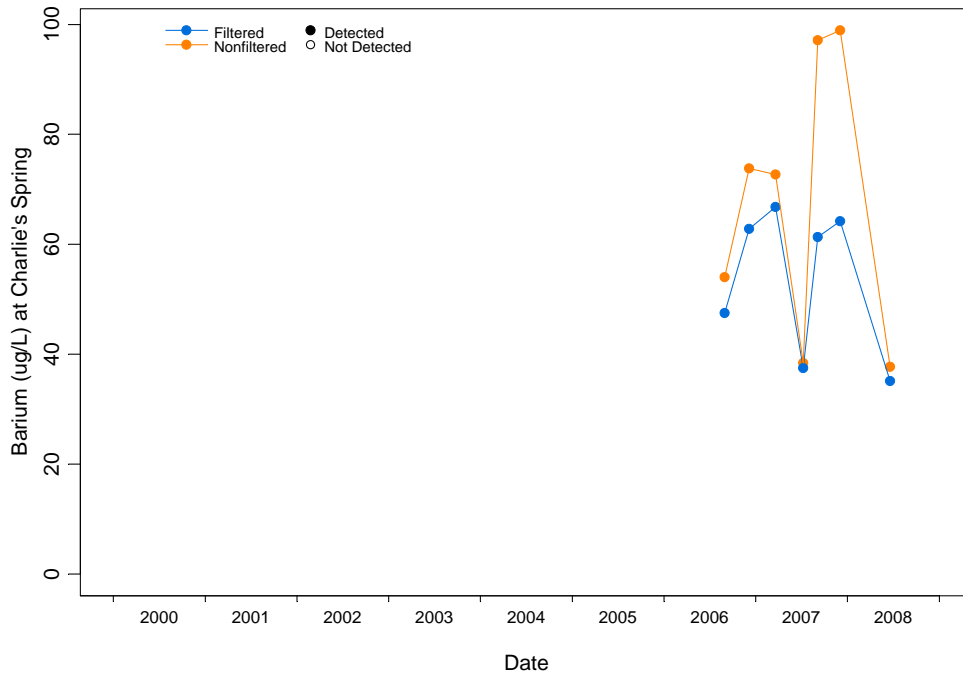

Figure D-2.2-130 Concentrations over time at Charlie's Spring for barium

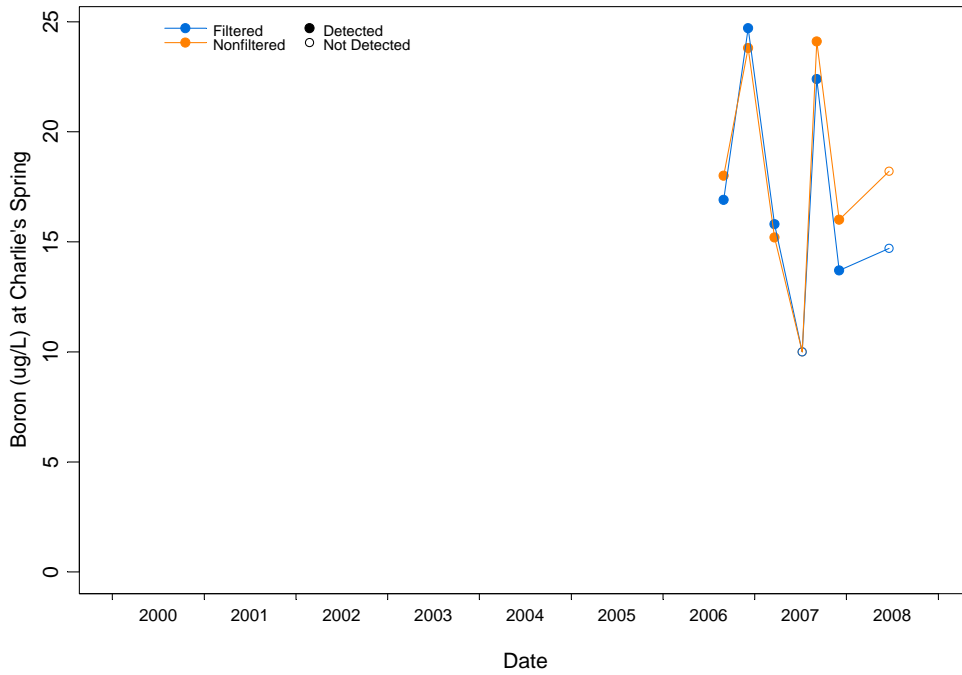

Figure D-2.2-131 Concentrations over time at Charlie's Spring for boron

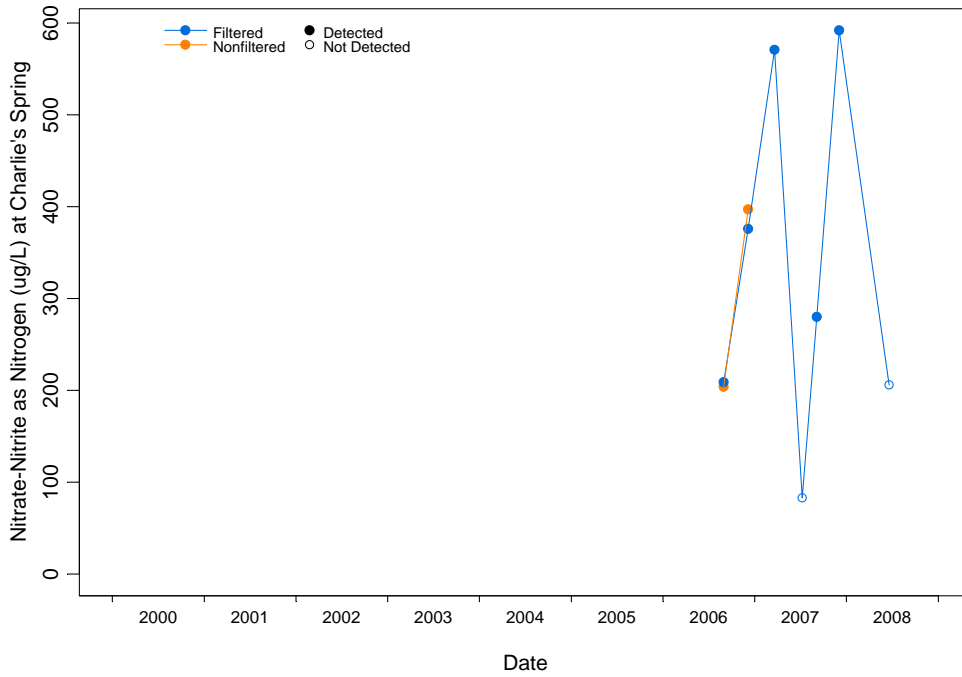

Figure D-2.2-132 Concentrations over time at Charlie's Spring for nitrate-nitrite as nitrogen

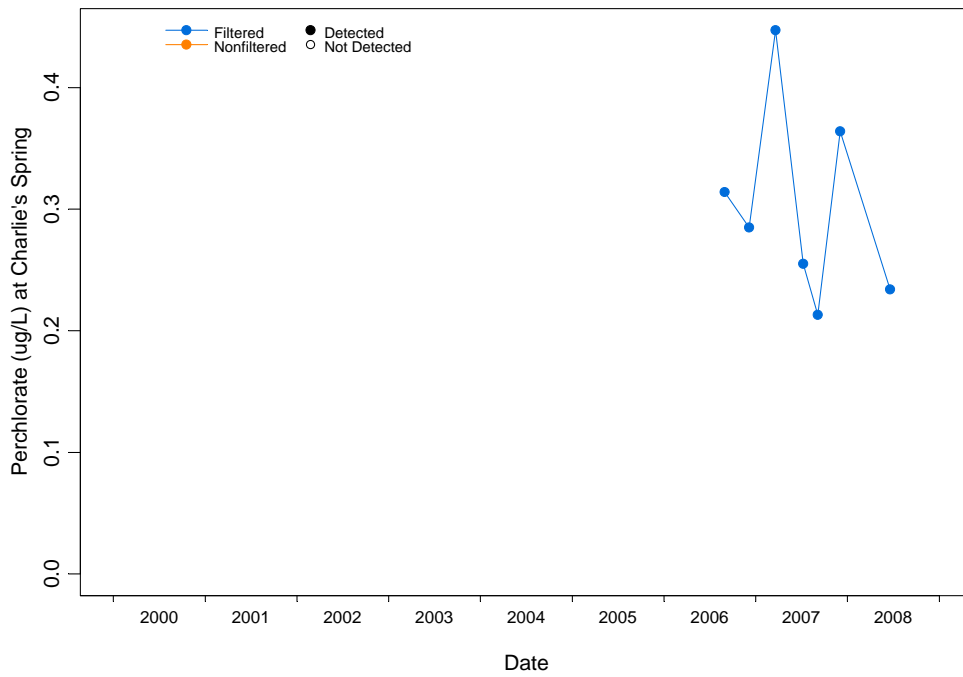

Figure D-2.2-133 Concentrations over time at Charlie's Spring for perchlorate

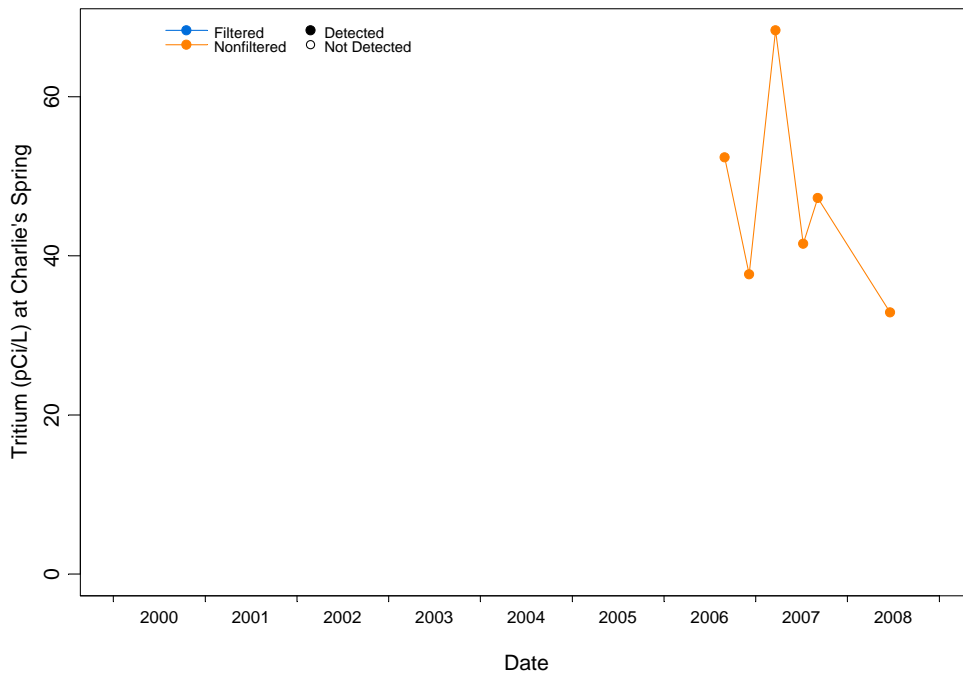

Figure D-2.2-134 Concentrations over time at Charlie's Spring for tritium

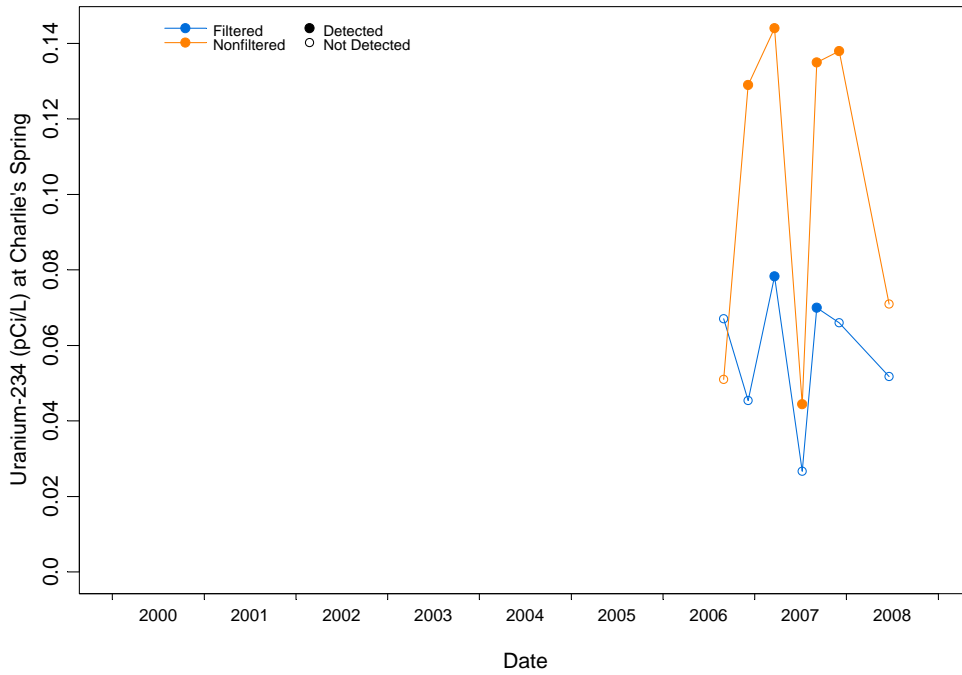

Figure D-2.2-135 Concentrations over time at Charlie's Spring for uranium-234

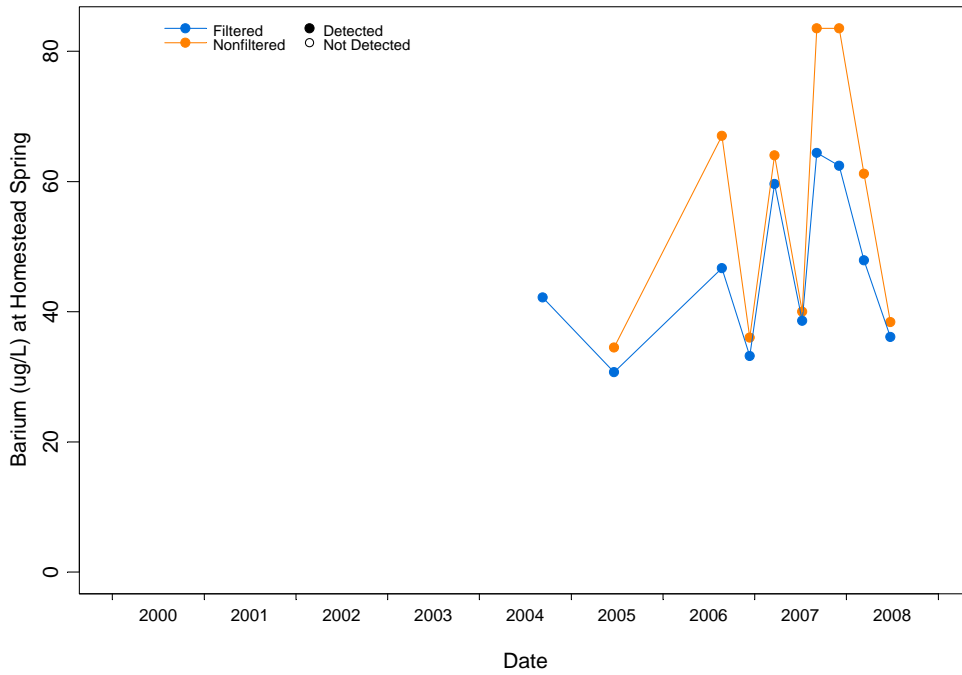

Figure D-2.2-136 Concentrations over time at Homestead Spring for barium

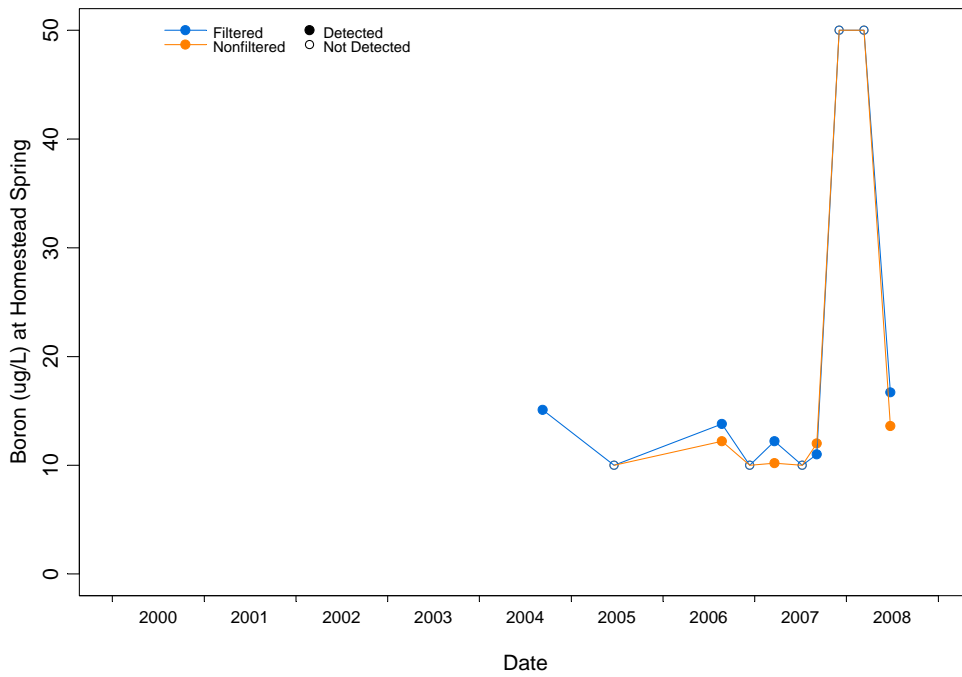

Figure D-2.2-137 Concentrations over time at Homestead Spring for boron

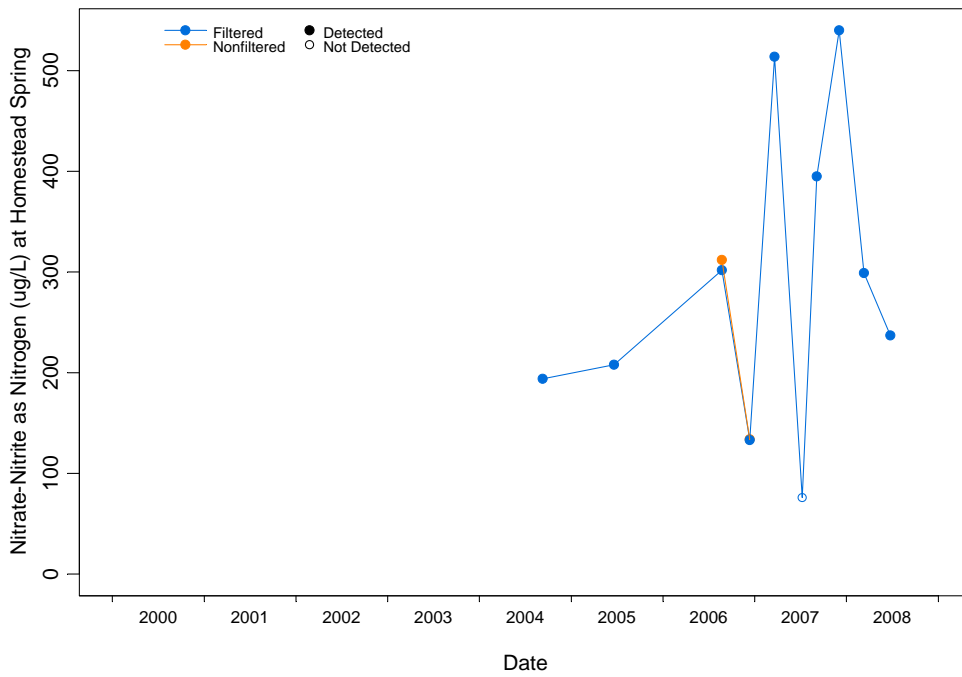

Figure D-2.2-138 Concentrations over time at Homestead Spring for nitrate-nitrite as nitrogen

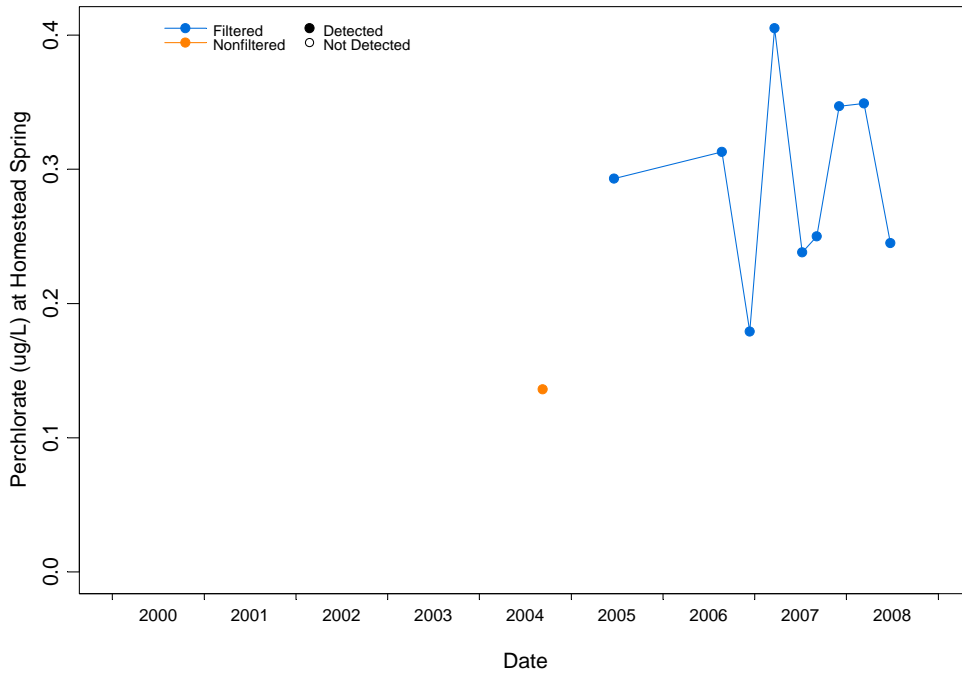

Figure D-2.2-139 Concentrations over time at Homestead Spring for perchlorate

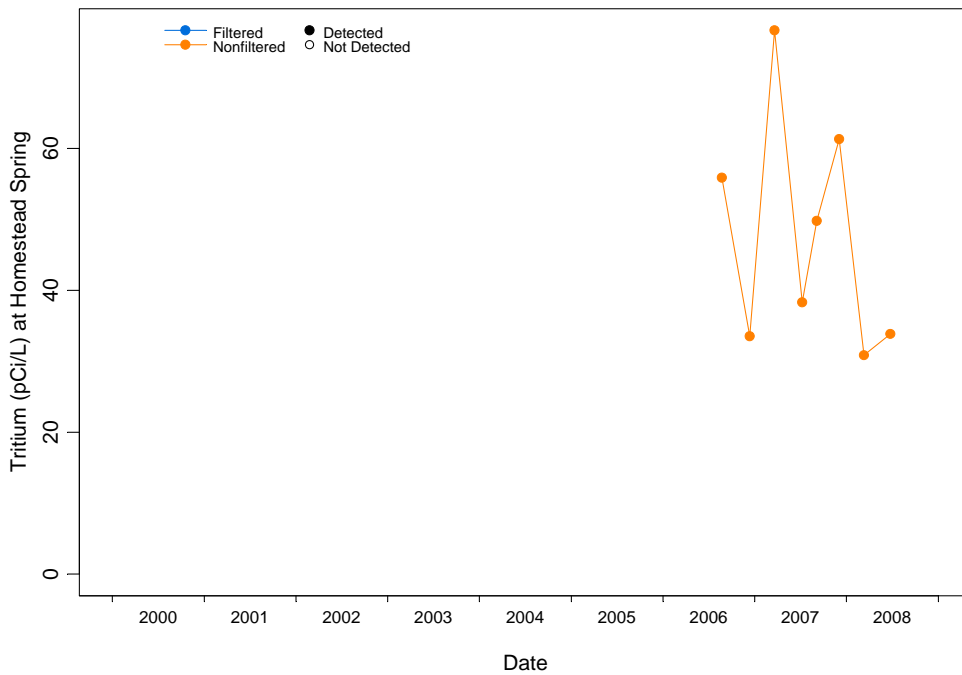

Figure D-2.2-140 Concentrations over time at Homestead Spring for tritium

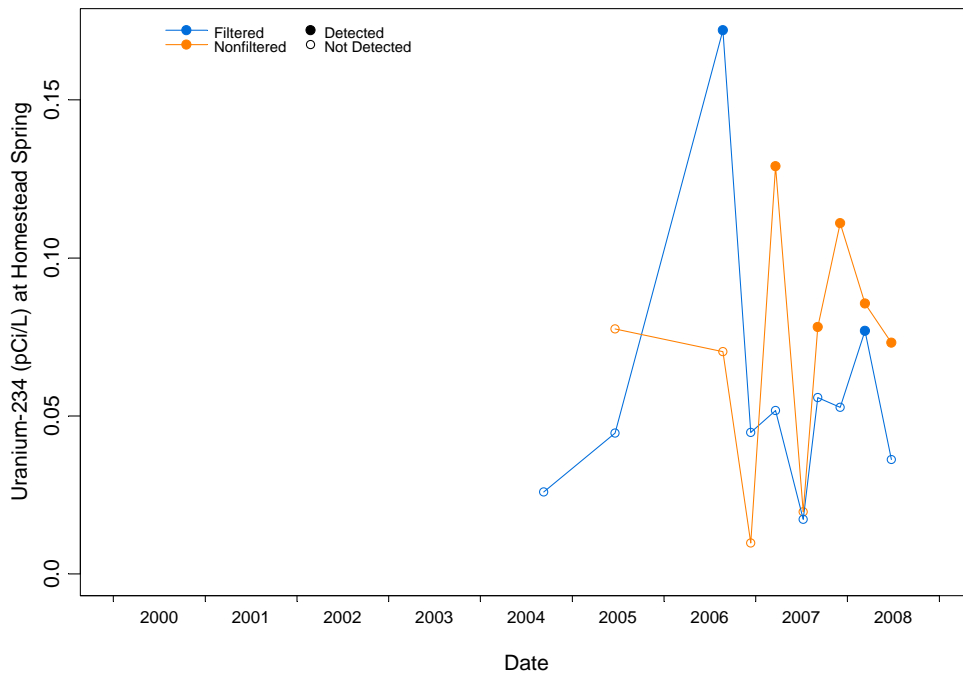

Figure D-2.2-141 Concentrations over time at Homestead Spring for uranium-234

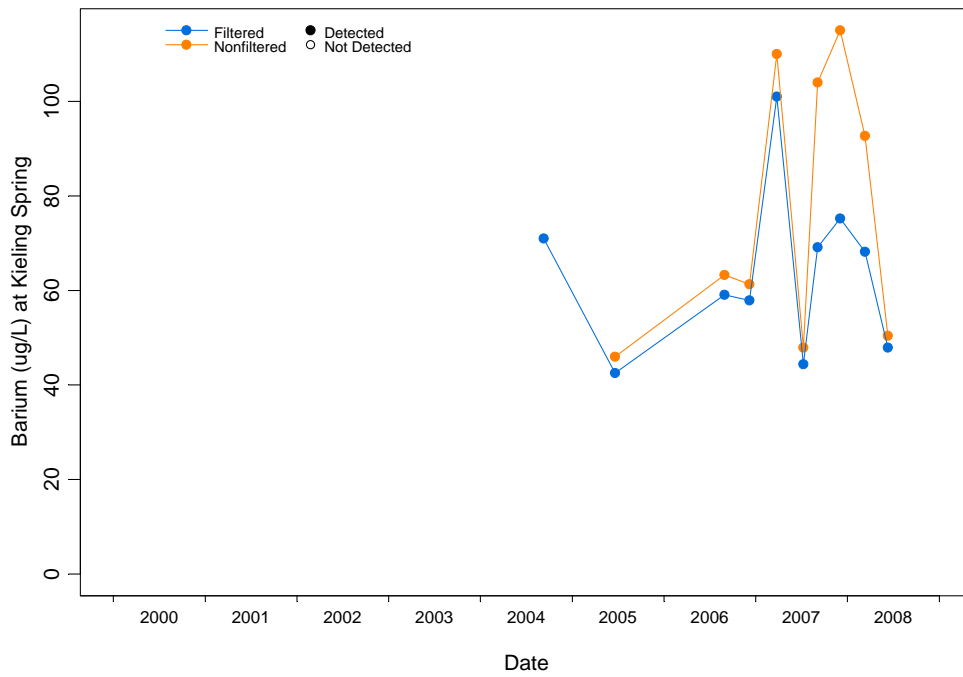

Figure D-2.2-142 Concentrations over time at Kieling Spring for barium

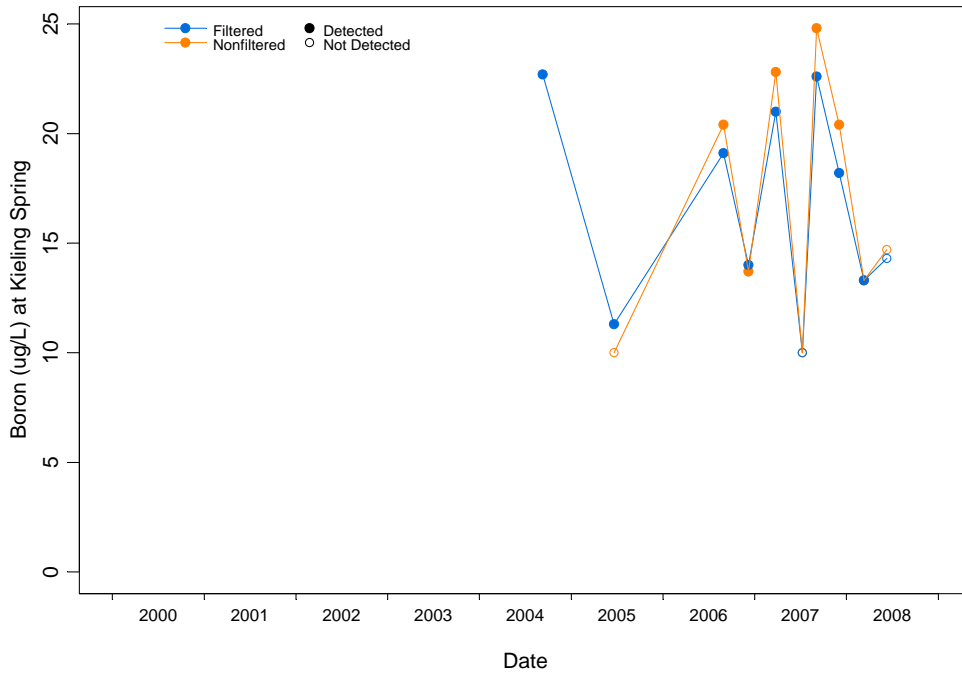

Figure D-2.2-143 Concentrations over time at Kieling Spring for boron

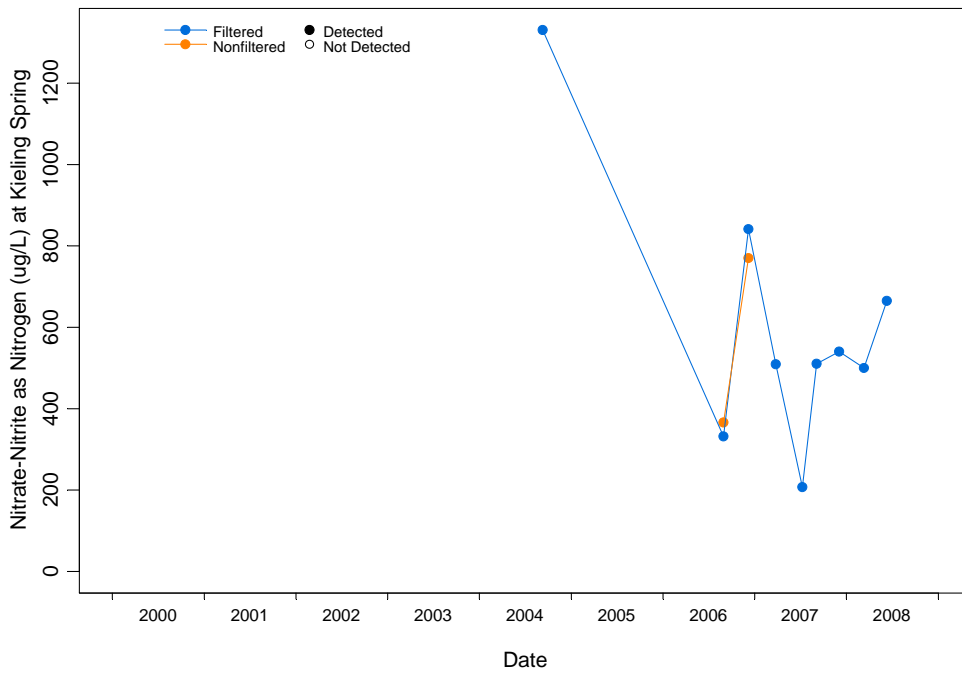

Figure D-2.2-144 Concentrations over time at Kieling Spring for nitrate-nitrite as nitrogen

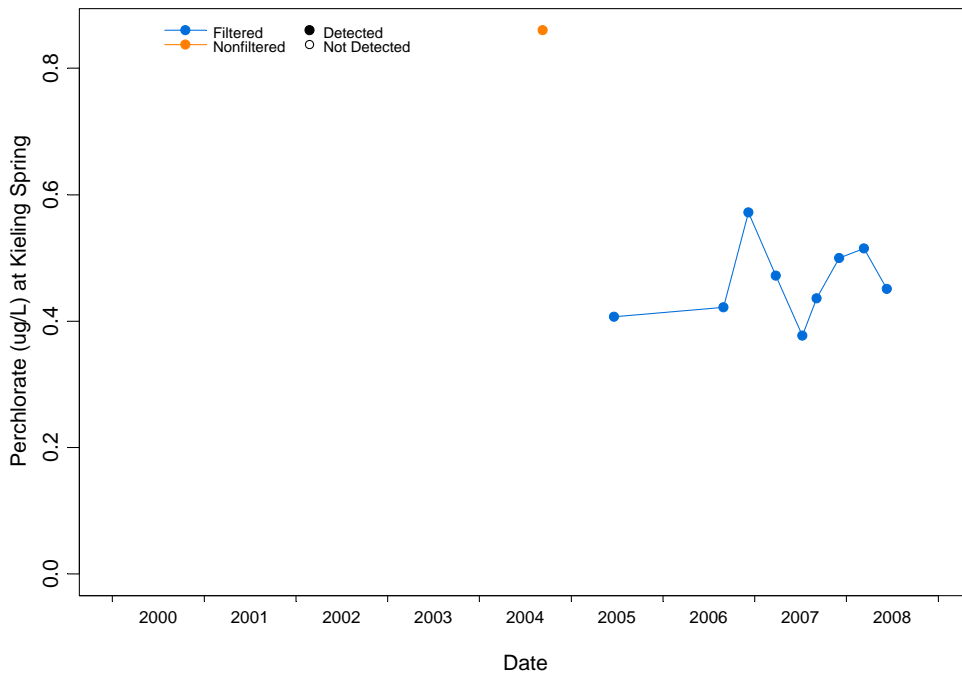

Figure D-2.2-145 Concentrations over time at Kieling Spring for perchlorate

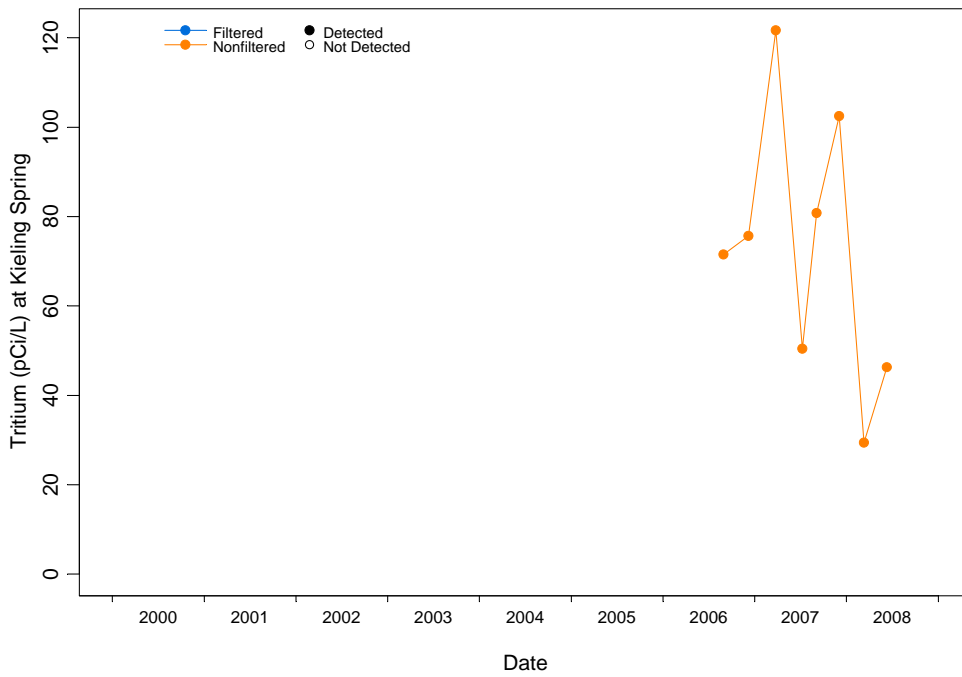

Figure D-2.2-146 Concentrations over time at Kieling Spring for tritium

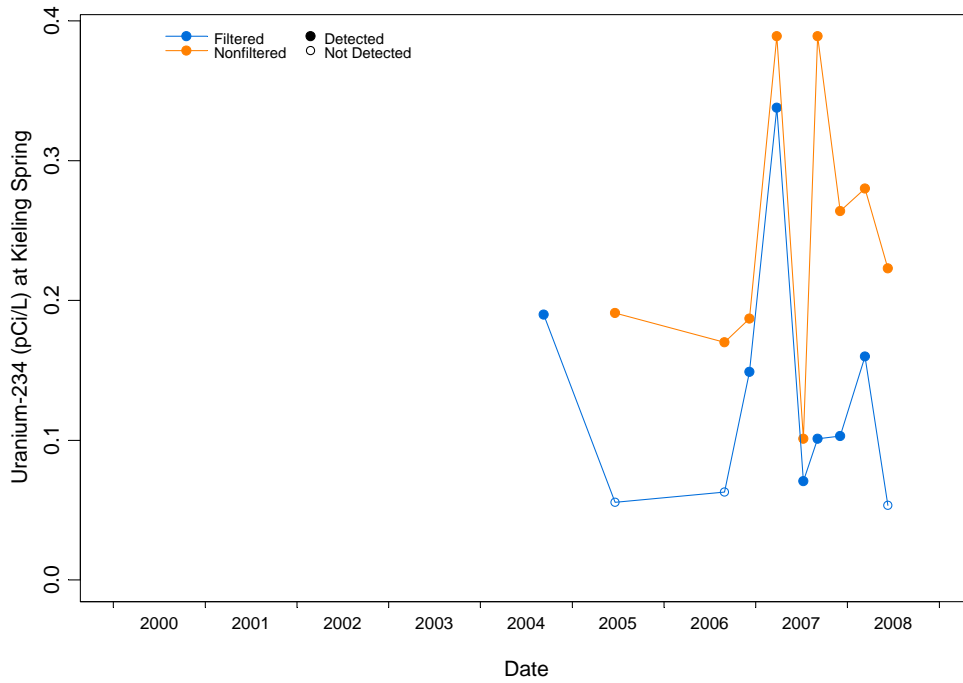

Figure D-2.2-147 Concentrations over time at Kieling Spring for uranium-234

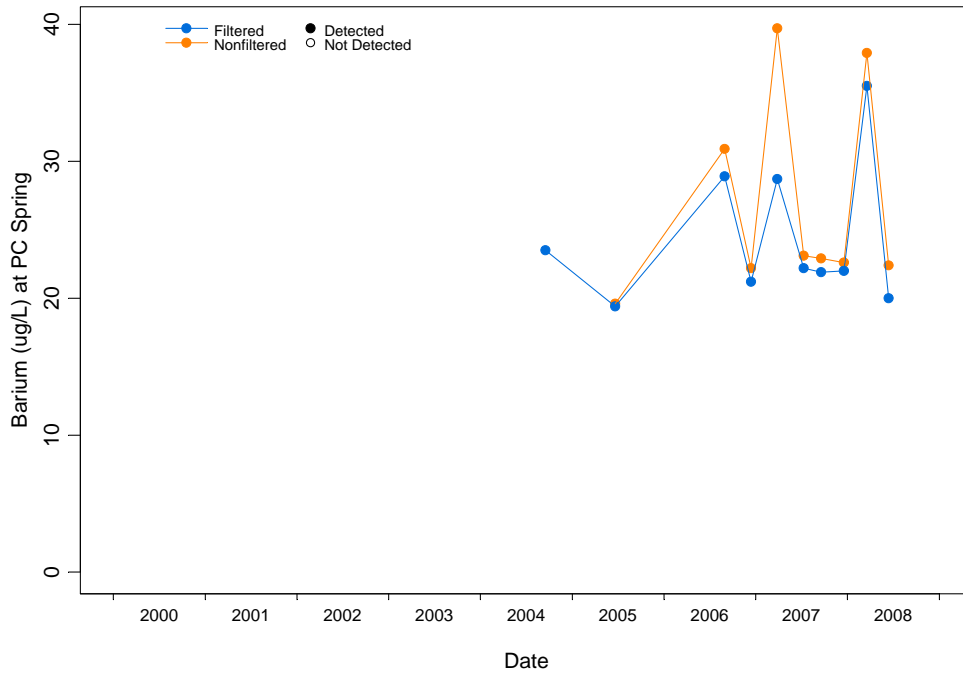

Figure D-2.2-148 Concentrations over time at PC Spring for barium

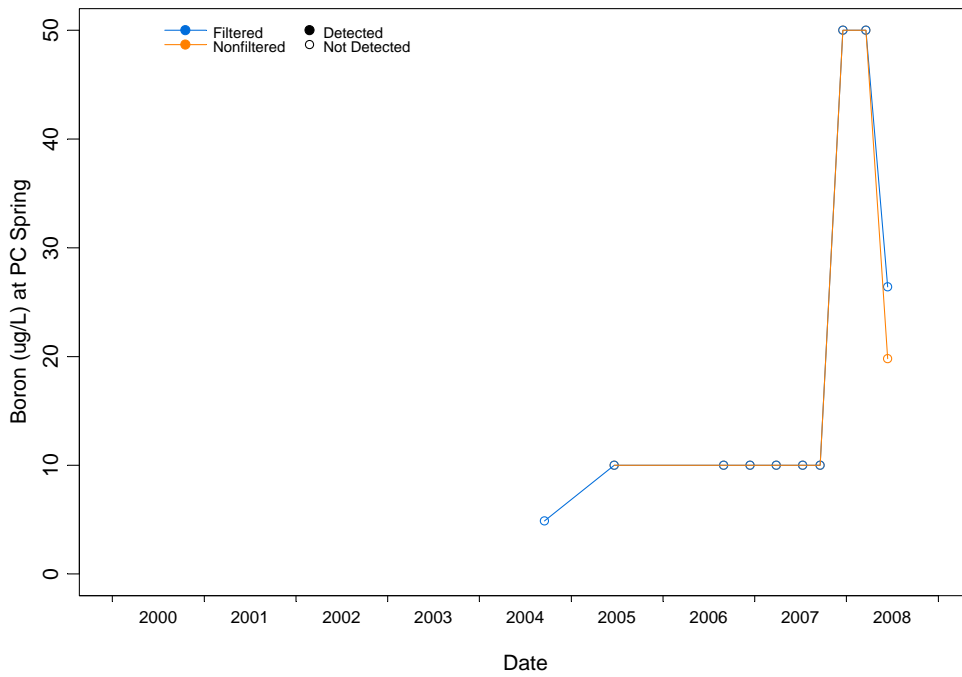

Figure D-2.2-149 Concentrations over time at PC Spring for boron

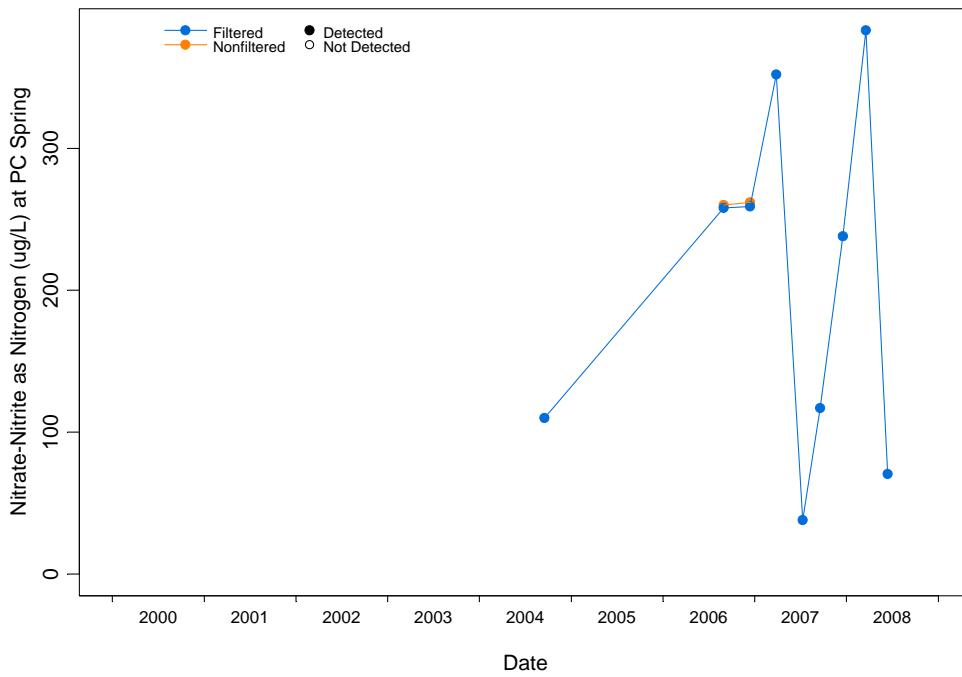

Figure D-2.2-150 Concentrations over time at PC Spring for nitrate-nitrite as nitrogen

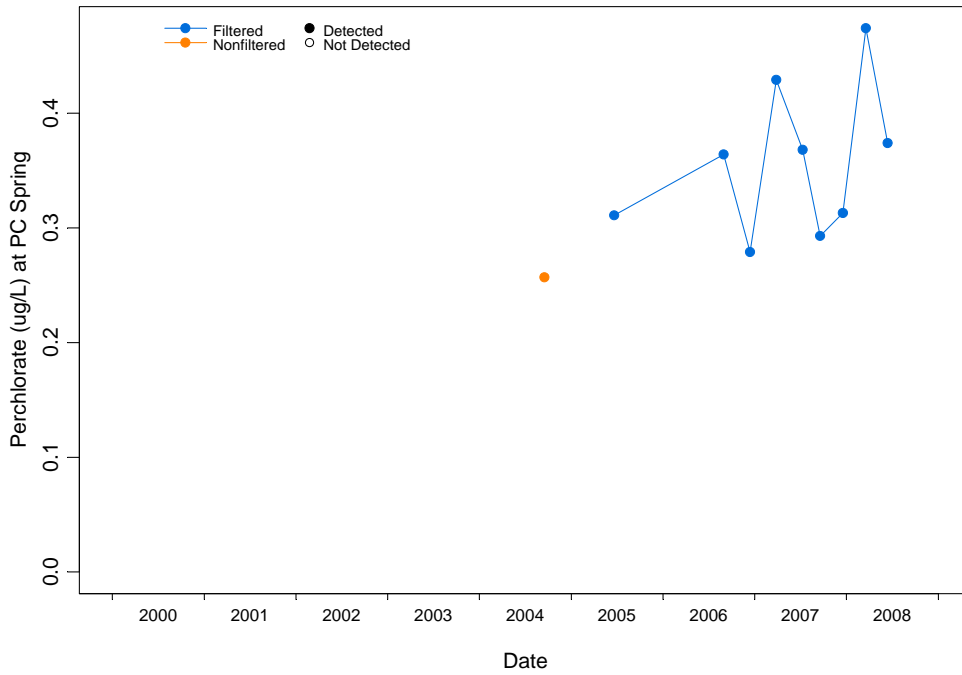

Figure D-2.2-151 Concentrations over time at PC Spring for perchlorate

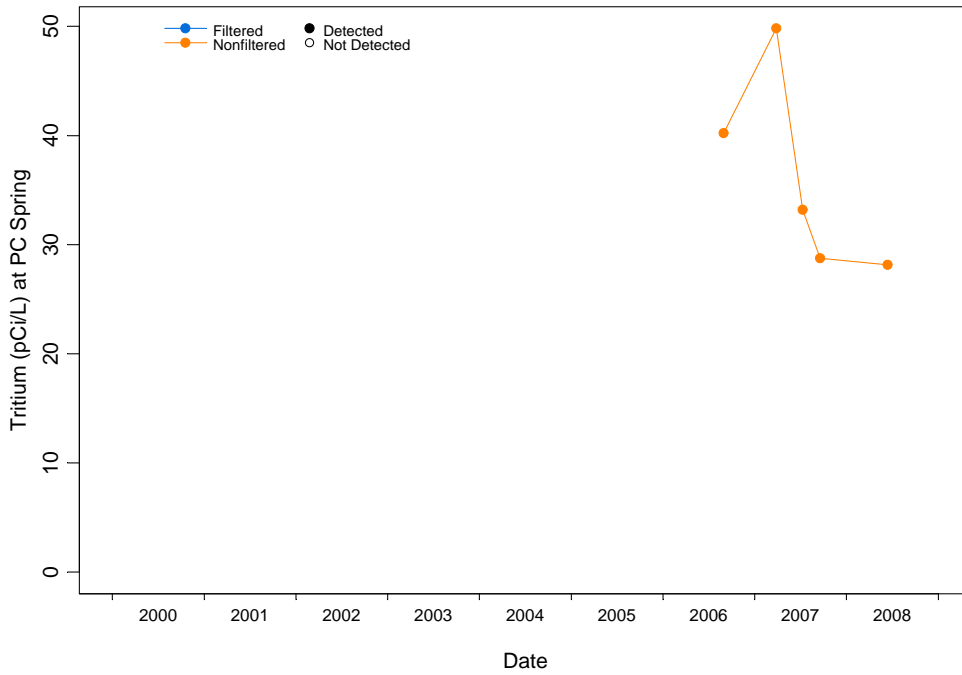

Figure D-2.2-152 Concentrations over time at PC Spring for tritium

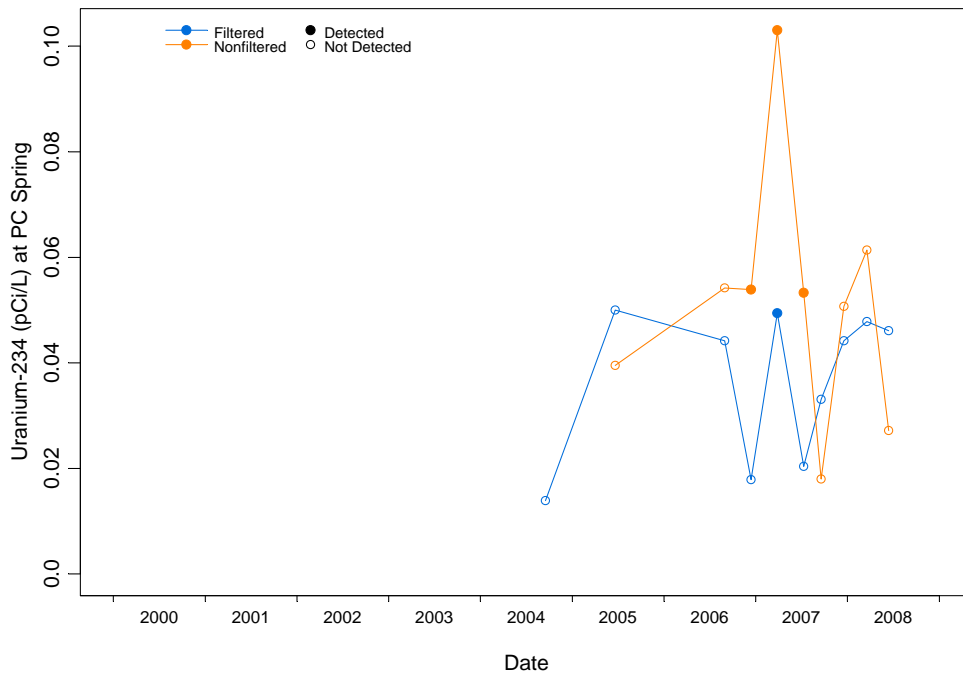

Figure D-2.2-153 Concentrations over time at PC Spring for uranium-234

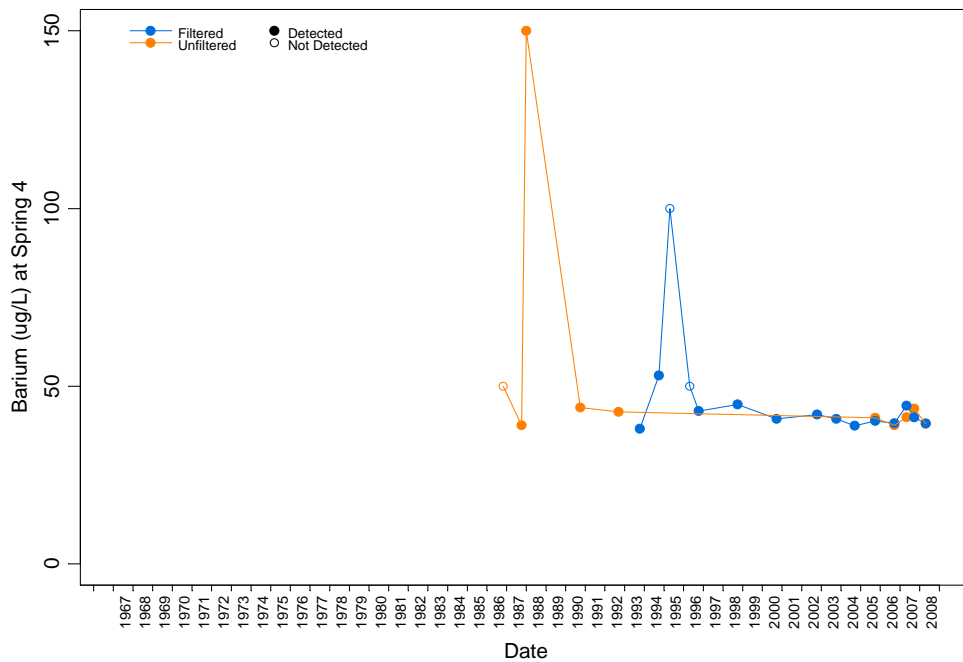

Figure D-2.2-154 Concentrations over time at Spring 4 for barium

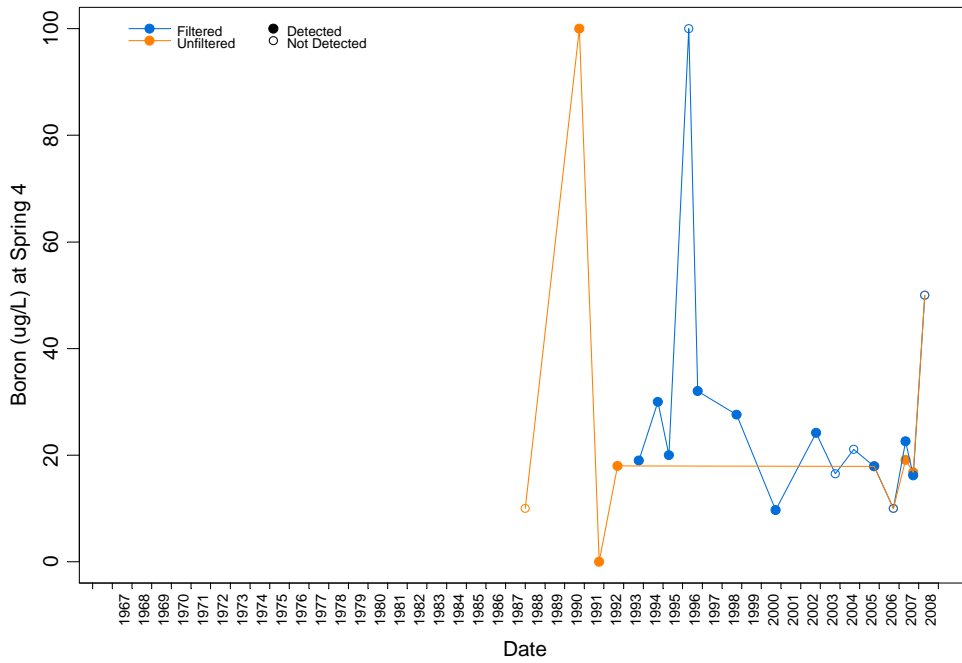

Figure D-2.2-155 Concentrations over time at Spring 4 for boron

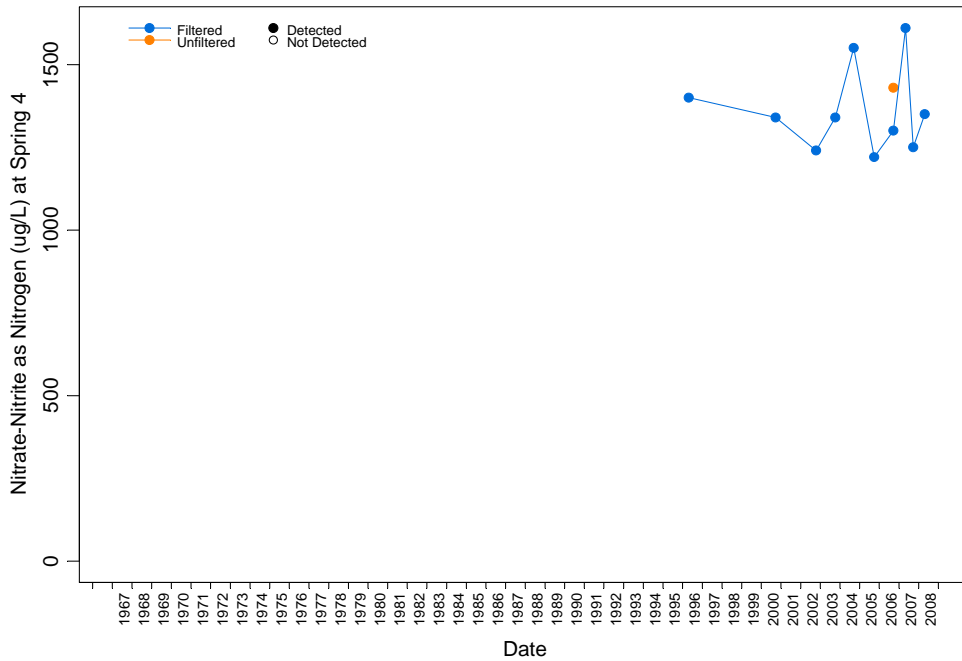

Figure D-2.2-156 Concentrations over time at Spring 4 for nitrate-nitrite as nitrogen

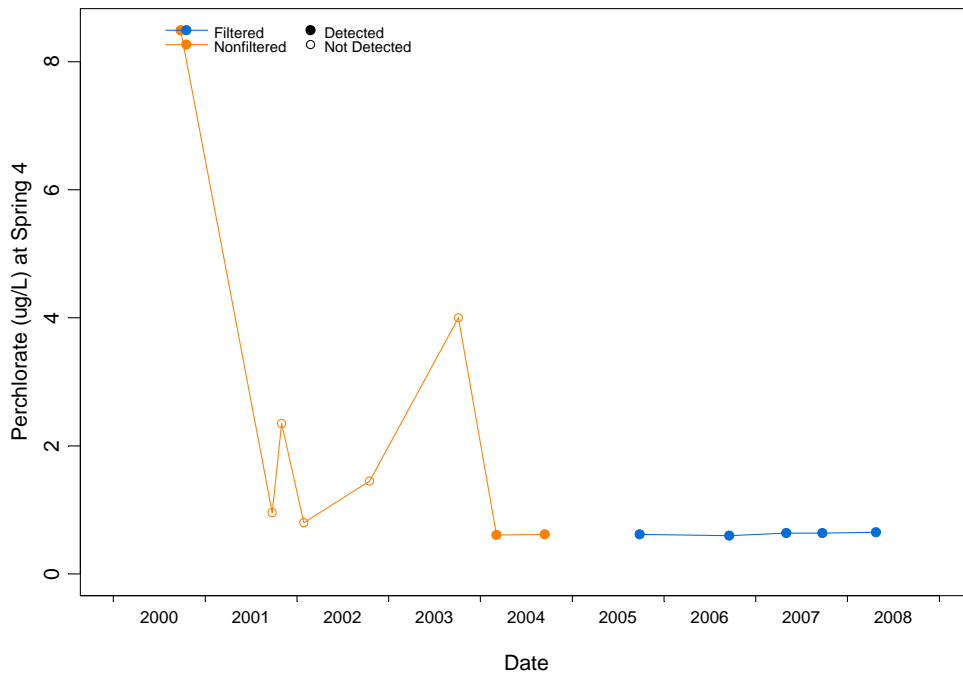

Figure D-2.2-157 Concentrations over time at Spring 4 for perchlorate - analytical method prior to 2004 is EPA:314, analytical method post 2003 is SW-846:6850

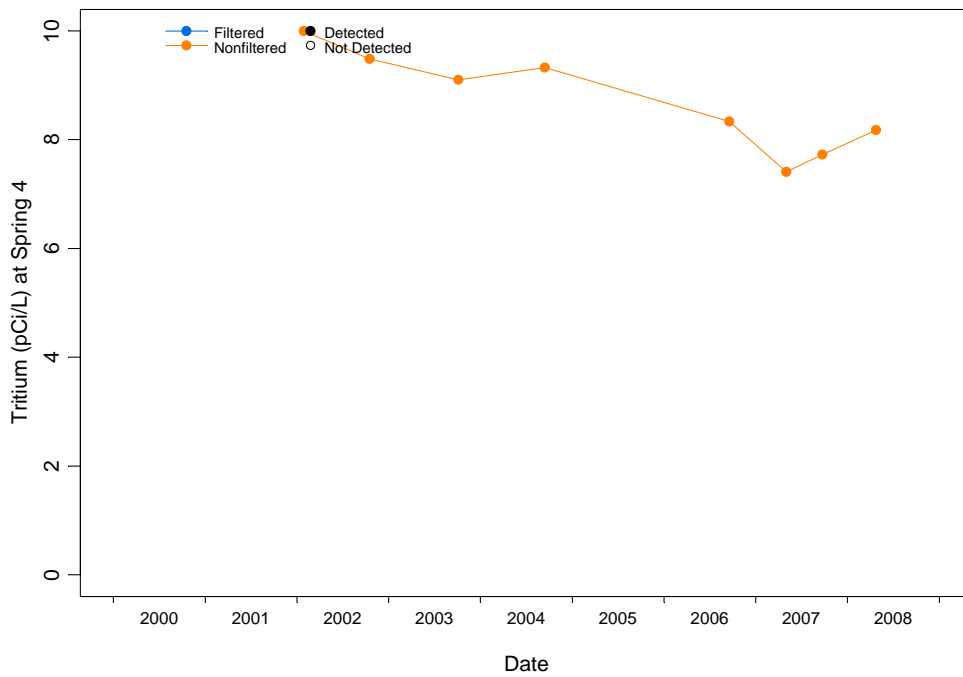

Figure D-2.2-158 Concentrations over time at Spring 4 for tritium

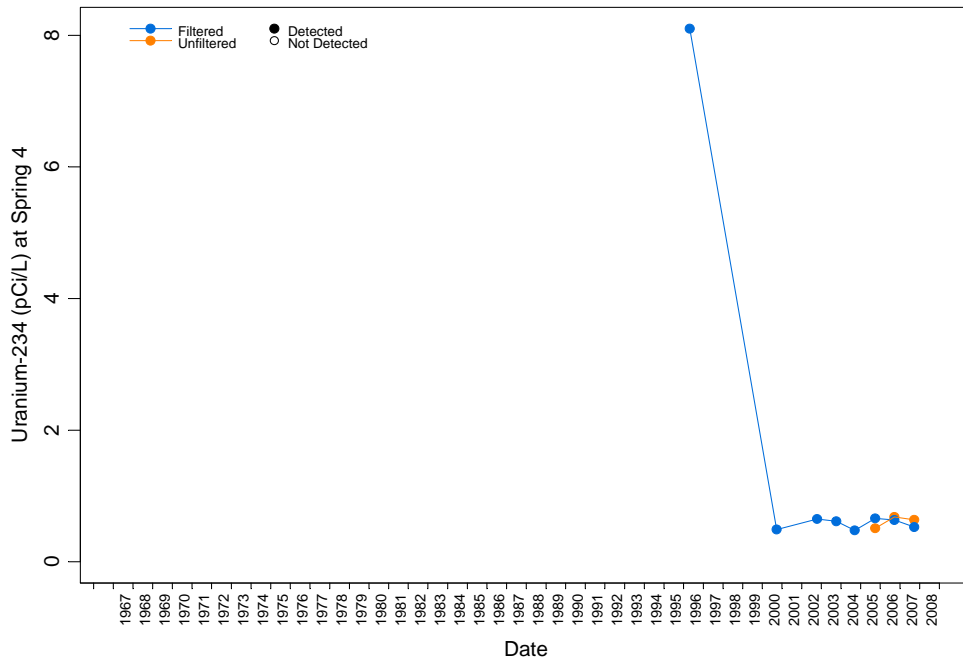

Figure D-2.2-159 Concentrations over time at Spring 4 for uranium-234

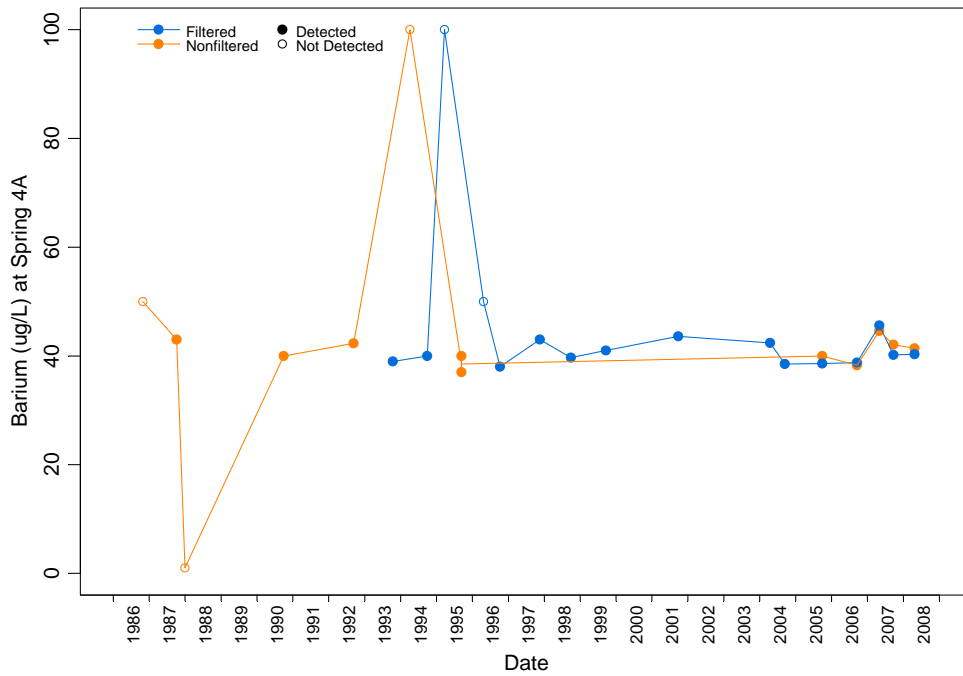

Figure D-2.2-160 Concentrations over time at Spring 4A for barium

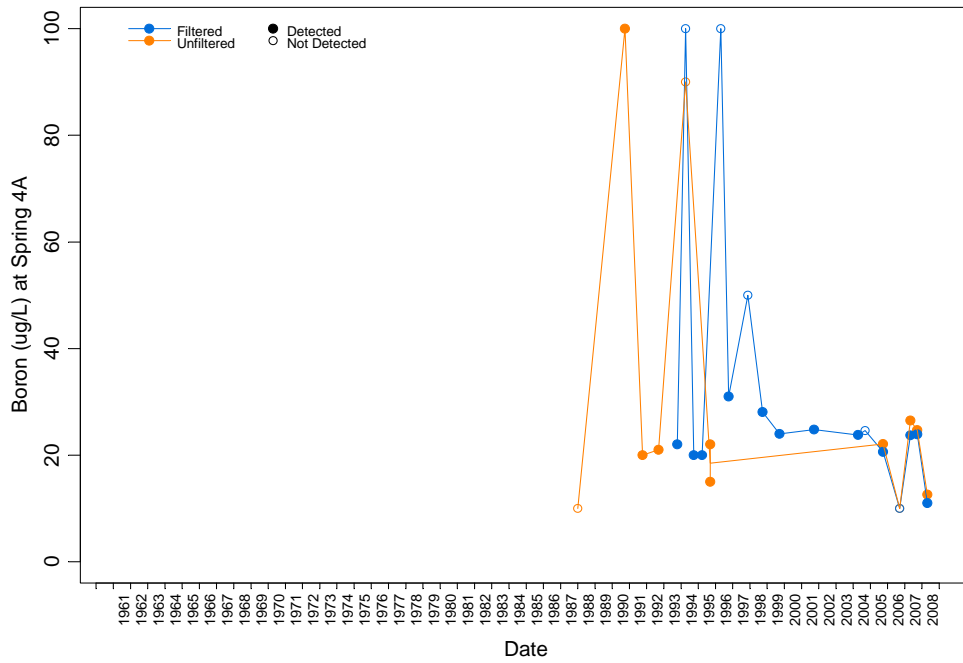

Figure D-2.2-161 Concentrations over time at Spring 4A for boron

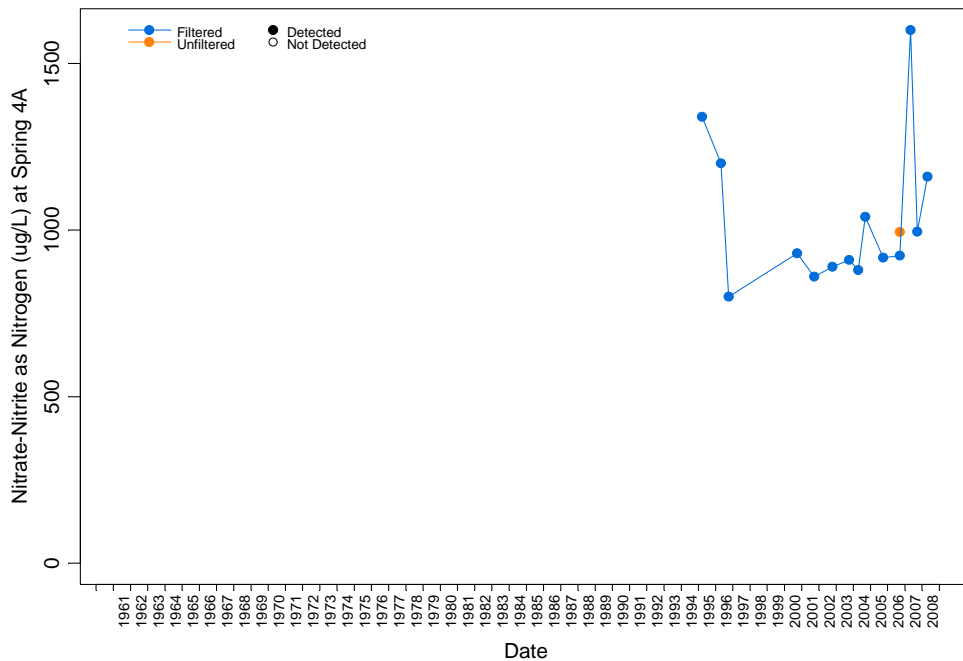

Figure D-2.2-162 Concentrations over time at Spring 4A for nitrate-nitrite as nitrogen

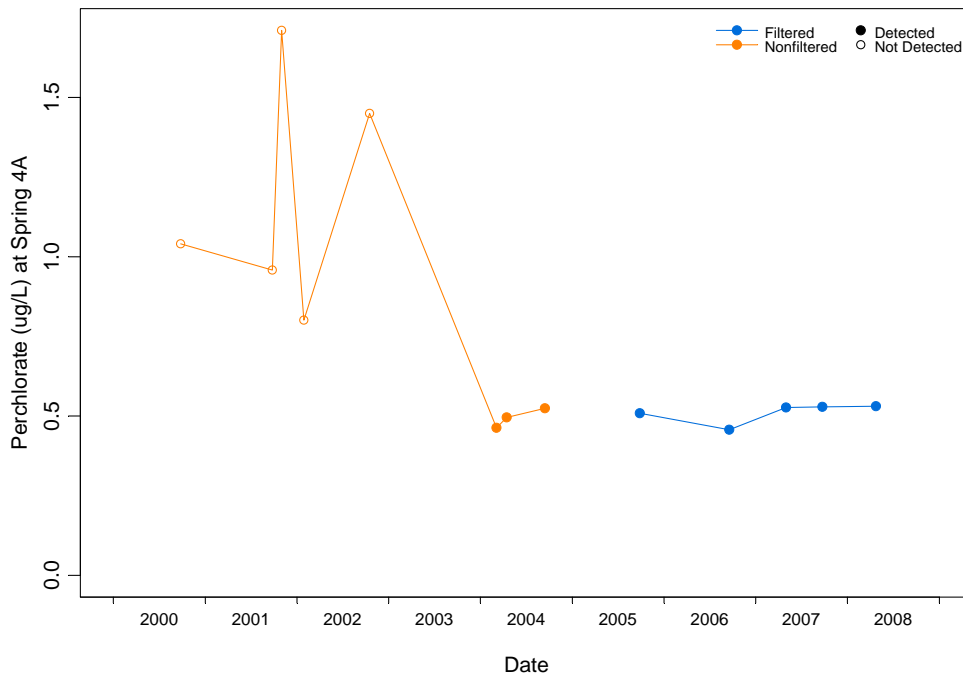

Figure D-2.2-163 Concentrations over time at Spring 4A for perchlorate - analytical method prior to 2004 is EPA:314, analytical method post 2003 is SW-846:6850

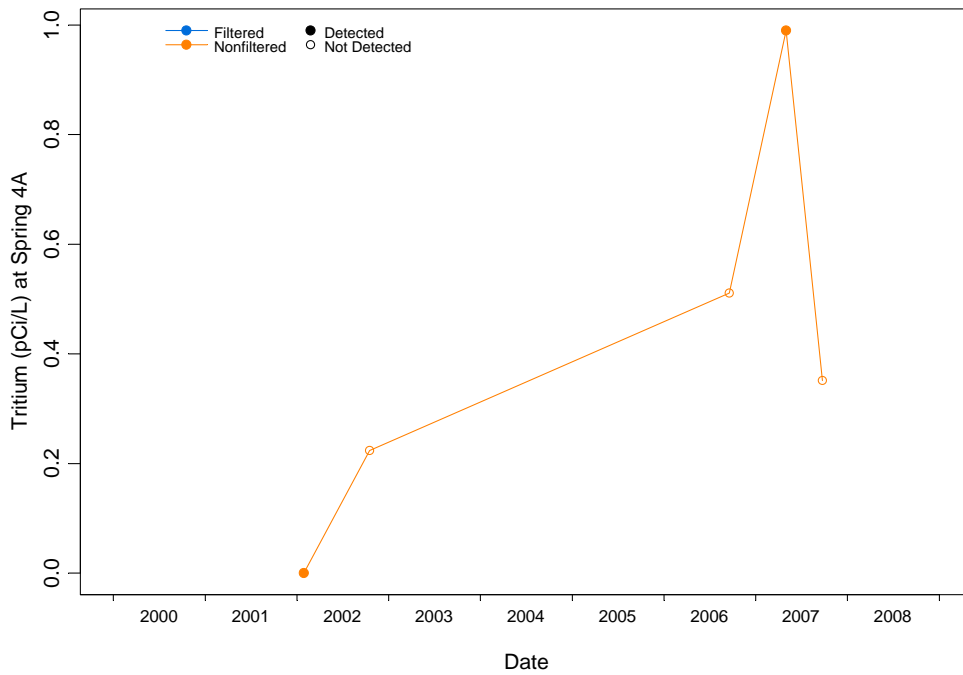

Figure D-2.2-164 Concentrations over time at Spring 4A for tritium

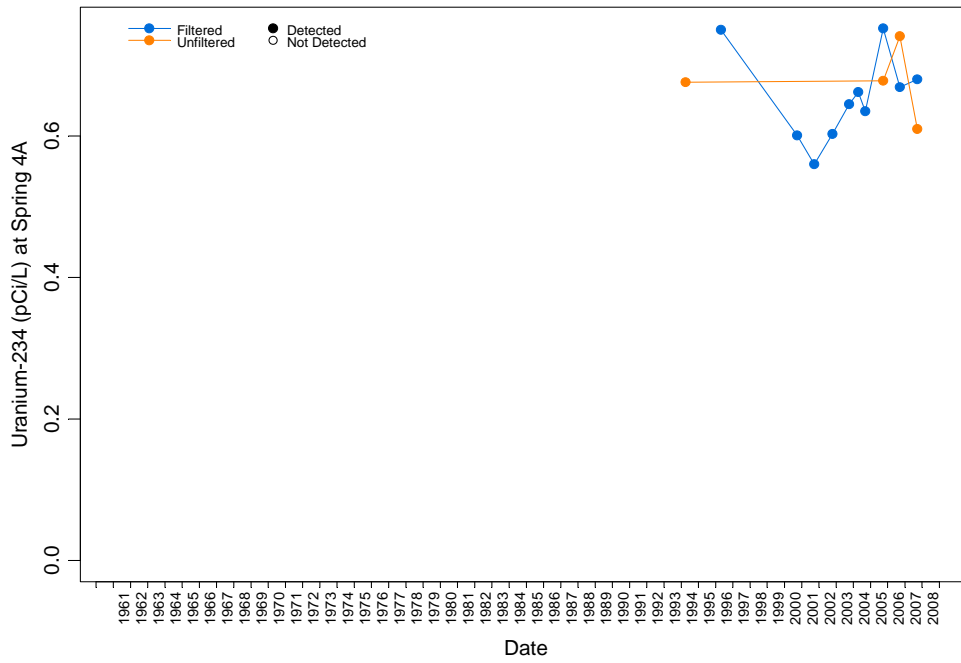

Figure D-2.2-165 Concentrations over time at Spring 4A for uranium-234

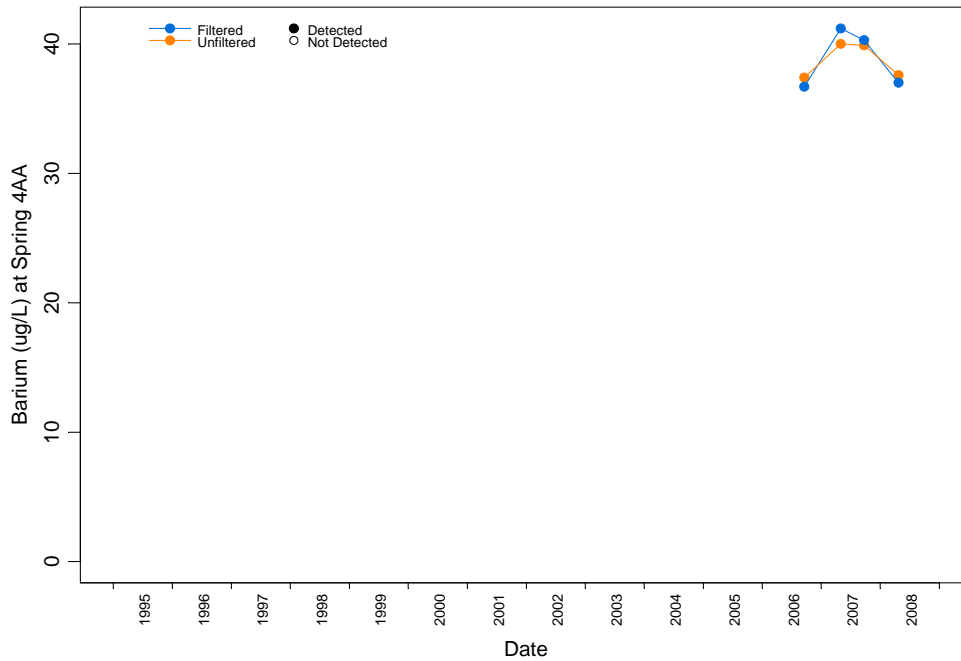

Figure D-2.2-166 Concentrations over time at Spring 4AA for barium

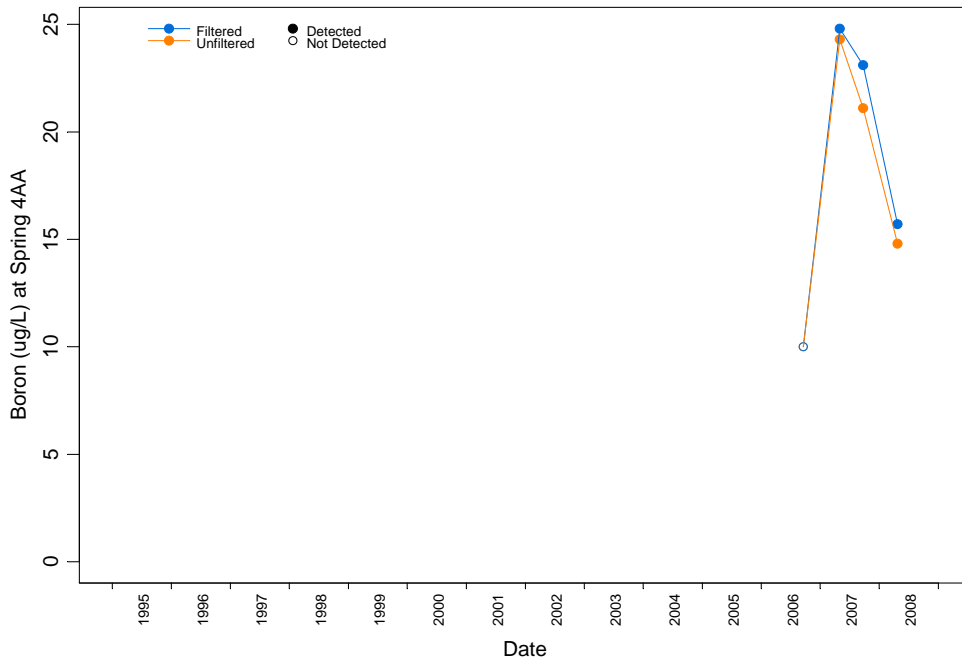

Figure D-2.2-167 Concentrations over time at Spring 4AA for boron

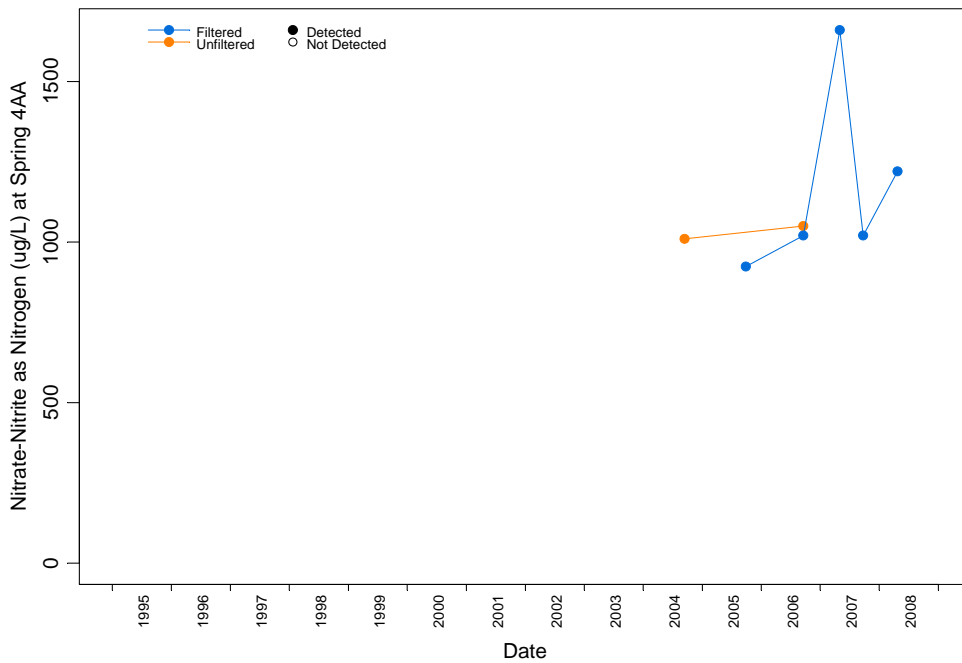

Figure D-2.2-168 Concentrations over time at Spring 4AA for nitrate-nitrite as nitrogen

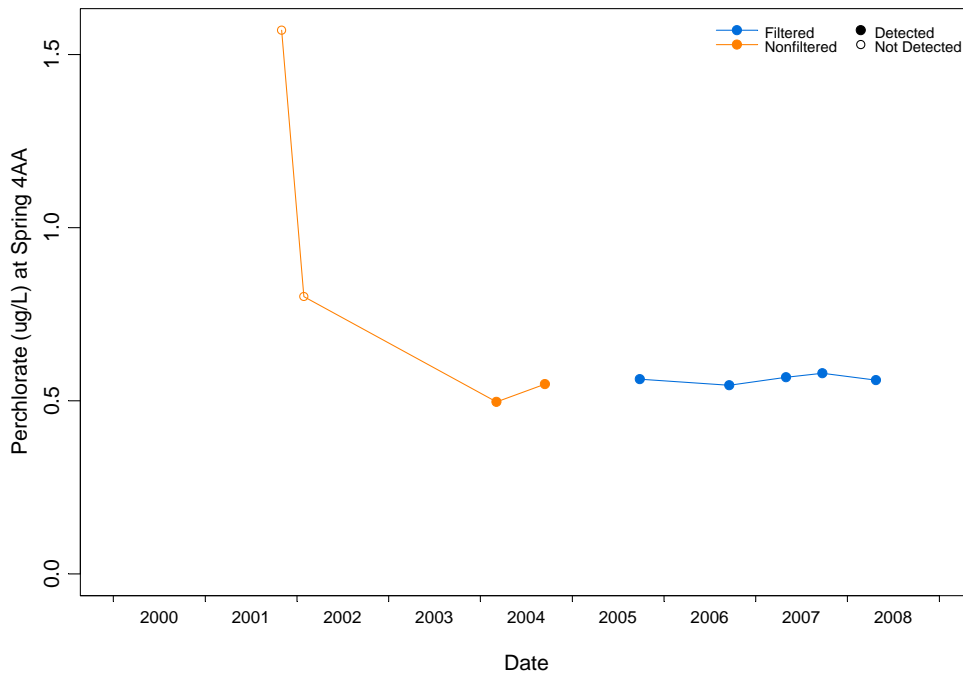

Figure D-2.2-169 Concentrations over time at Spring 4AA for Perchlorate—analytical method prior to 2004 is EPA:314, analytical method post-2003 is SW-846:6850

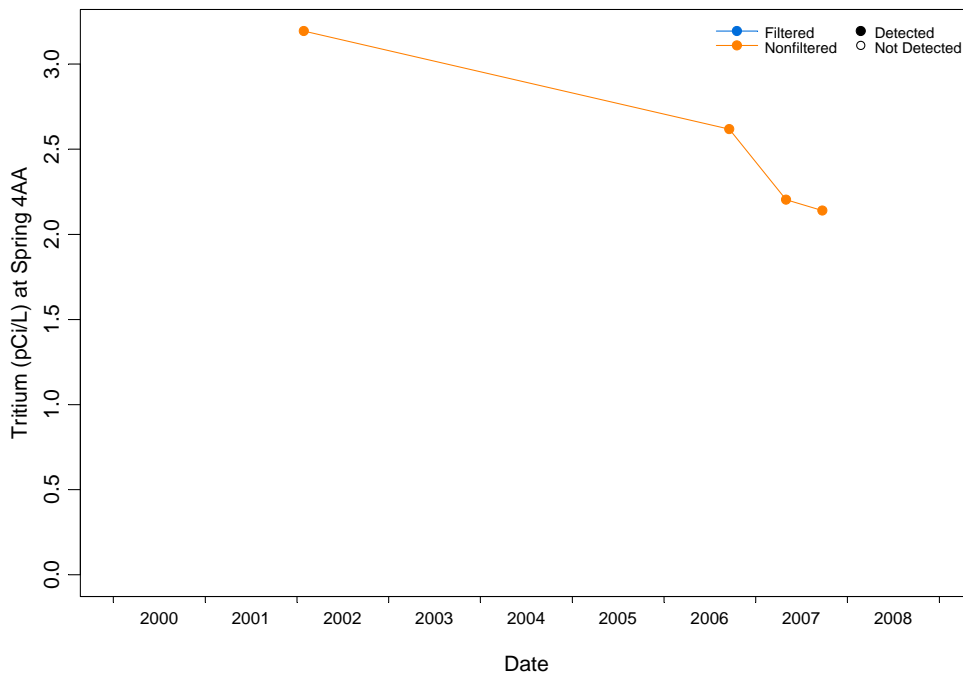

Figure D-2.2-170 Concentrations over time at Spring 4AA for tritium

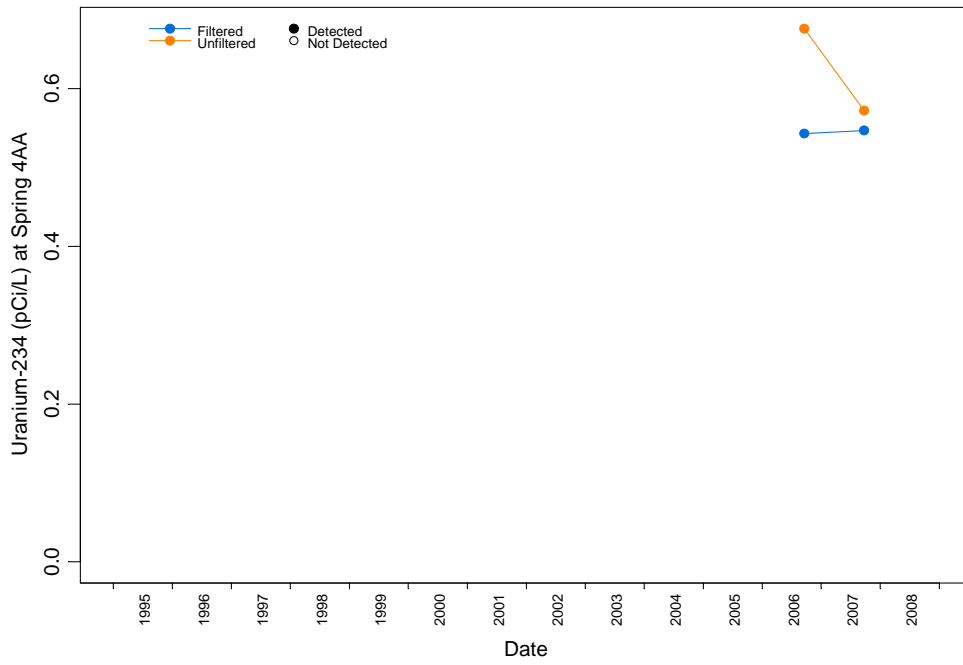

Figure D-2.2-171 Concentrations over time at Spring 4AA for uranium-234

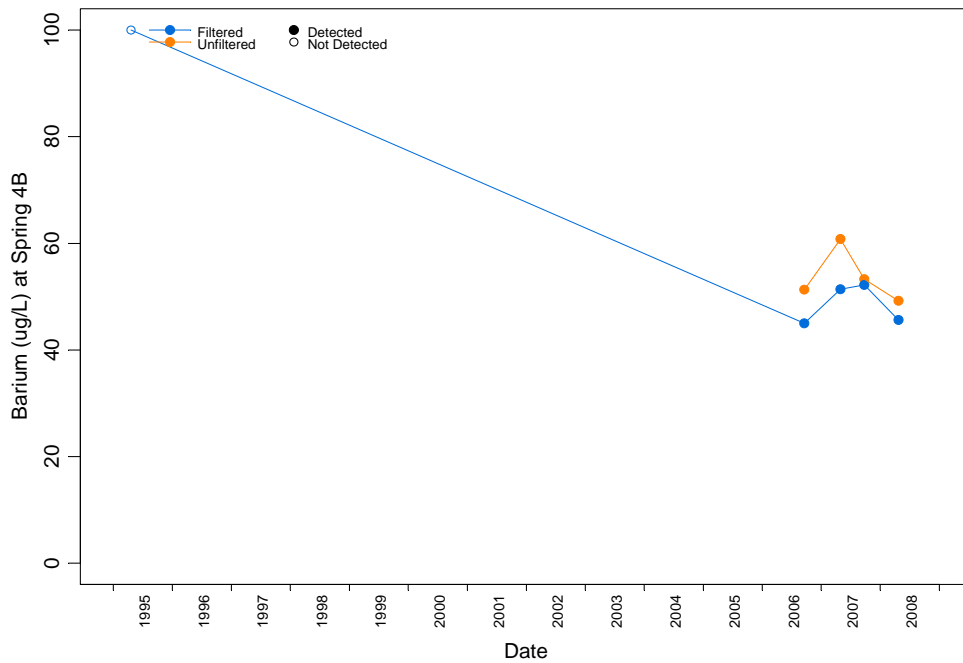

Figure D-2.2-172 Concentrations over time at Spring 4B for barium

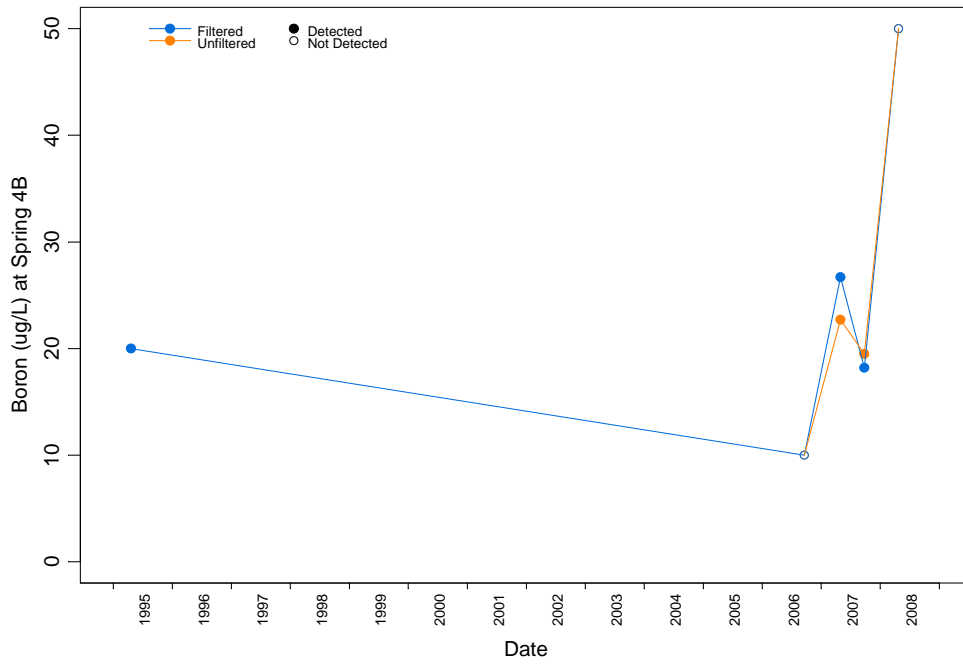

Figure D-2.2-173 Concentrations over time at Spring 4B for boron

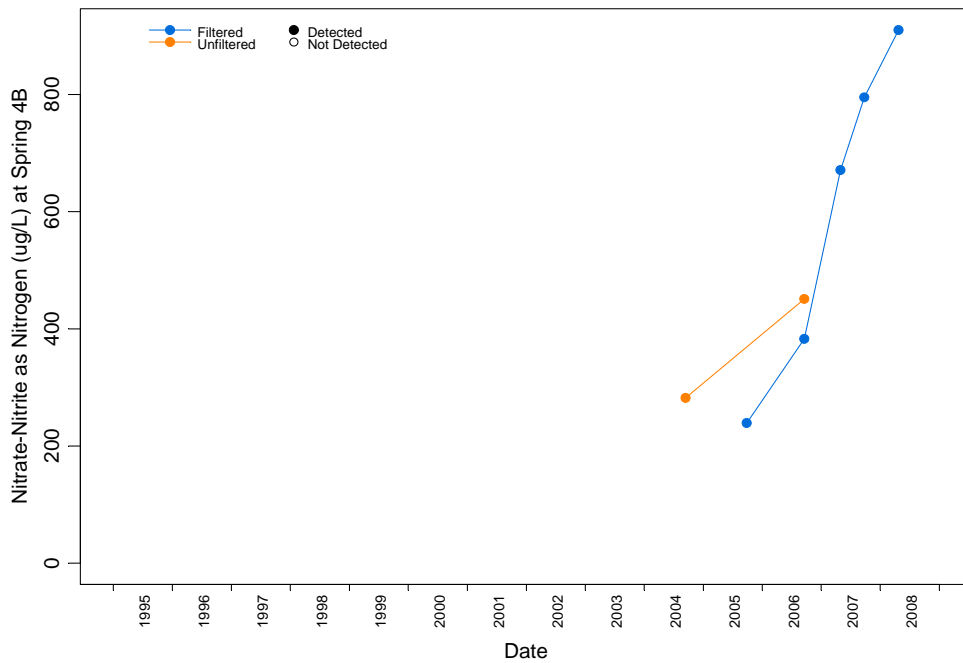

Figure D-2.2-174 Concentrations over time at Spring 4B for nitrate-nitrite as nitrogen

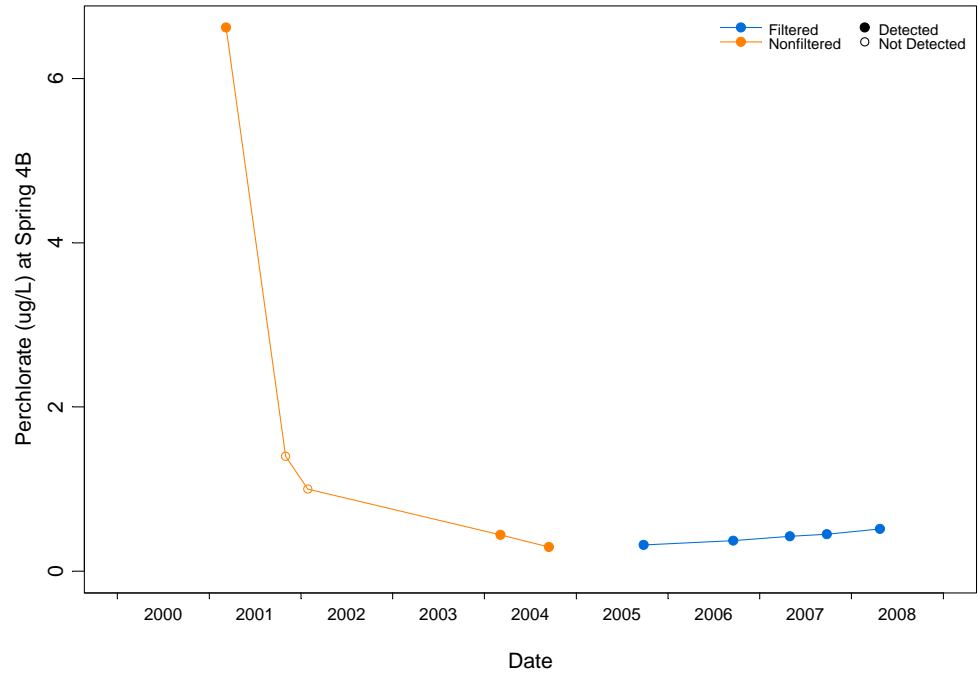

Figure D-2.2-175 Concentrations over time at Spring 4B for Perchlorate—analytical method before 2004 is EPA:314, analytical method post-2003 is SW-846:6850

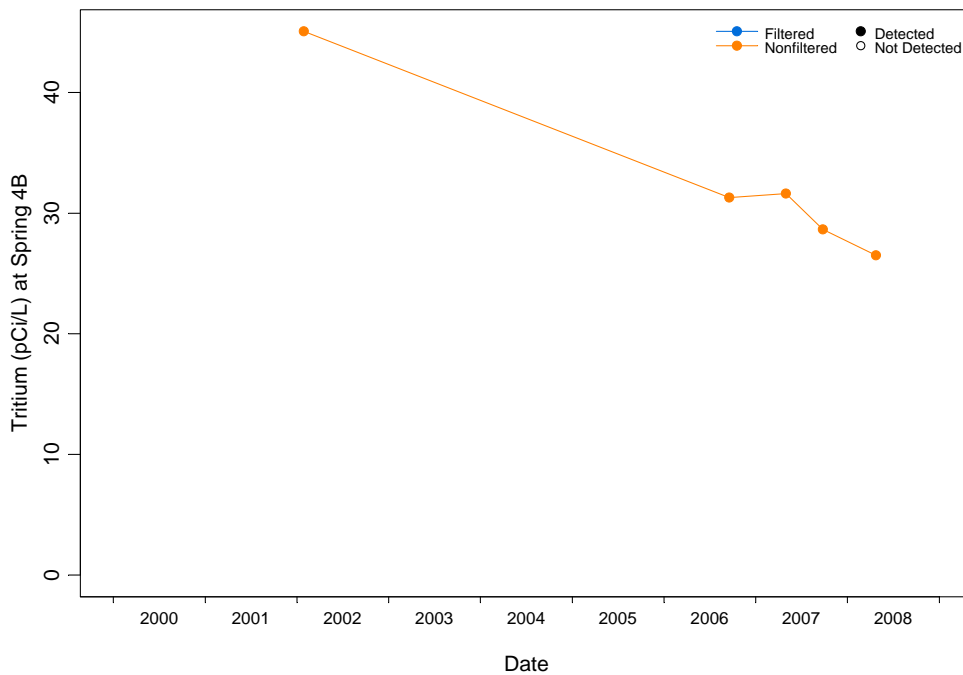

Figure D-2.2-176 Concentrations over time at Spring 4B for tritium

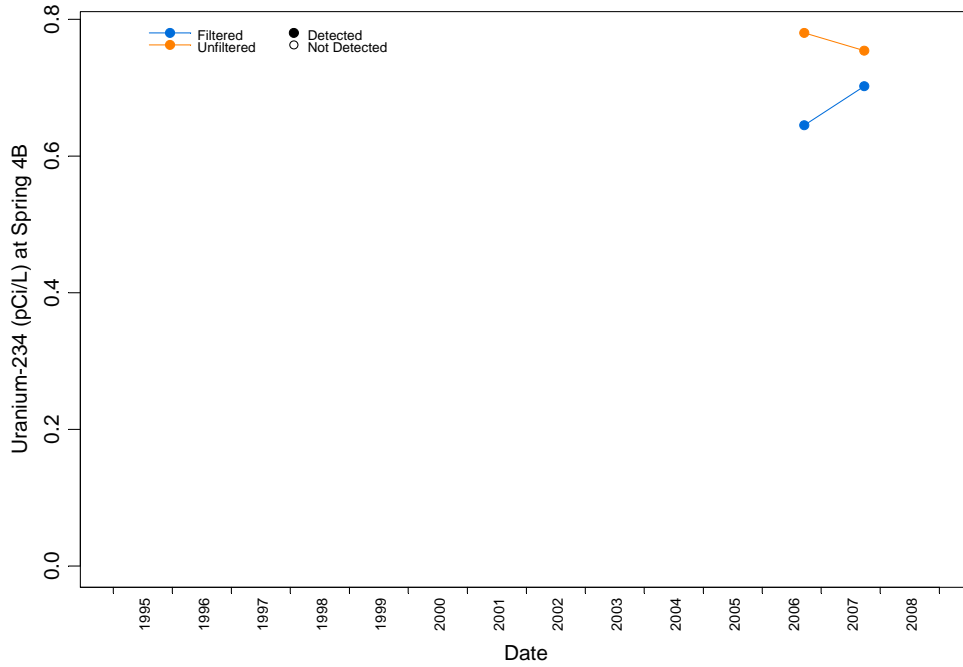

Figure D-2.2-177 Concentrations over time at Spring 4B for uranium-234

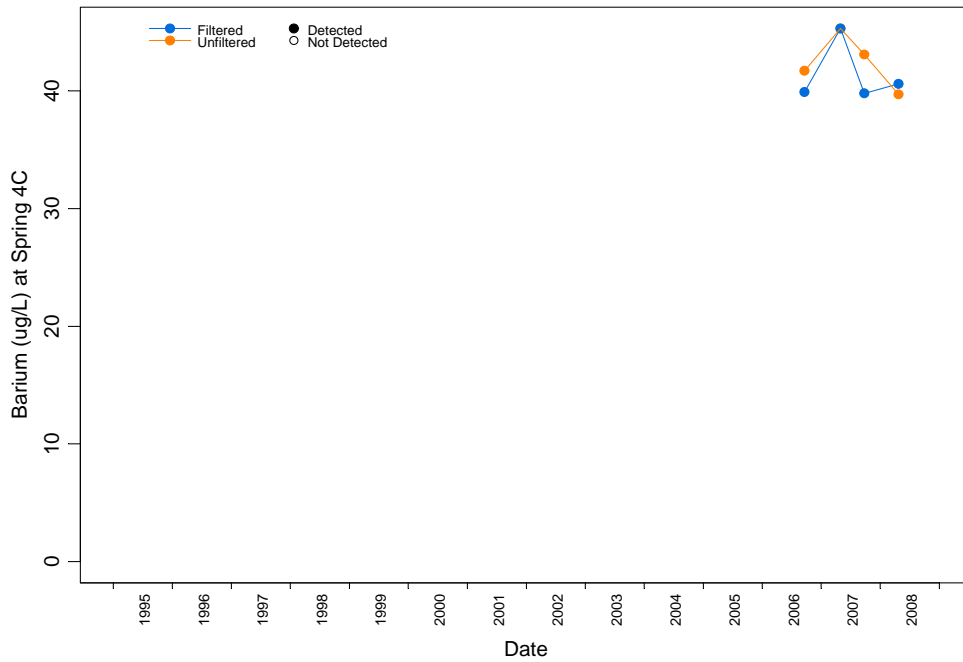

Figure D-2.2-178 Concentrations over time at Spring 4C for barium

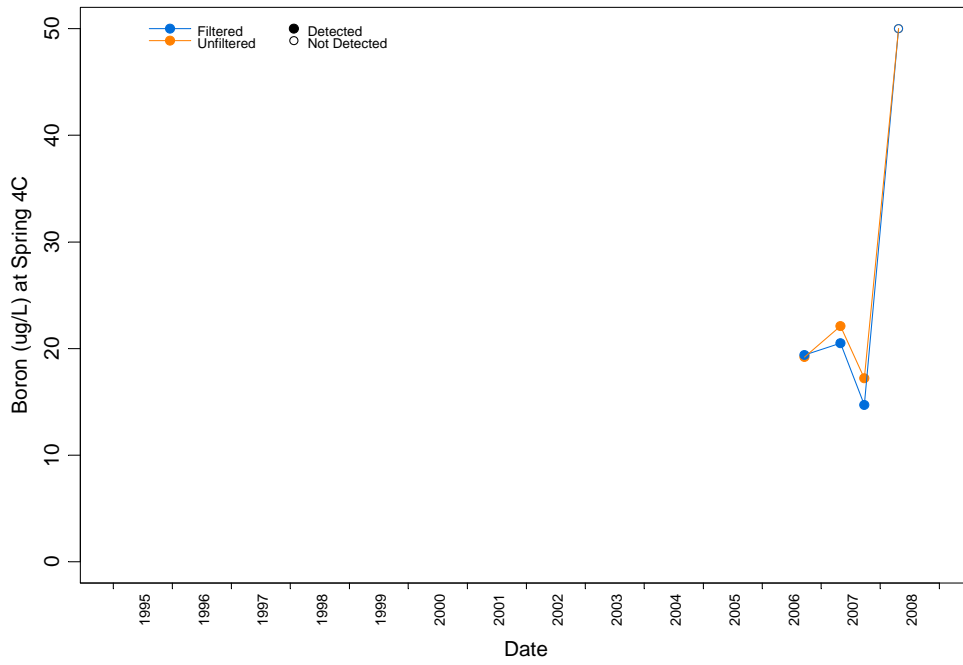

Figure D-2.2-179 Concentrations over time at Spring 4C for boron

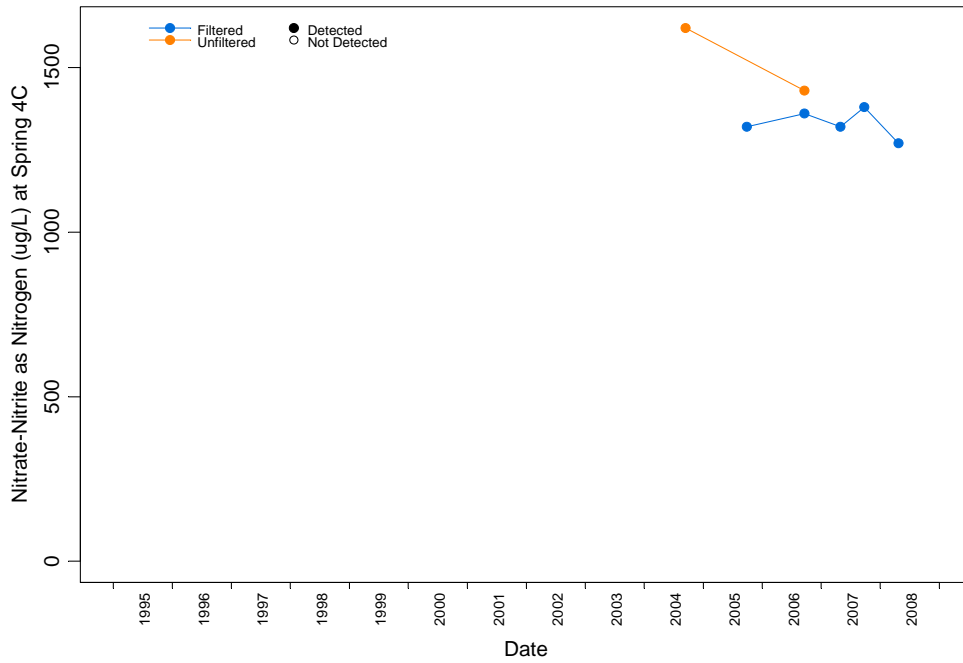

Figure D-2.2-180 Concentrations over time at Spring 4C for nitrate-nitrite as nitrogen

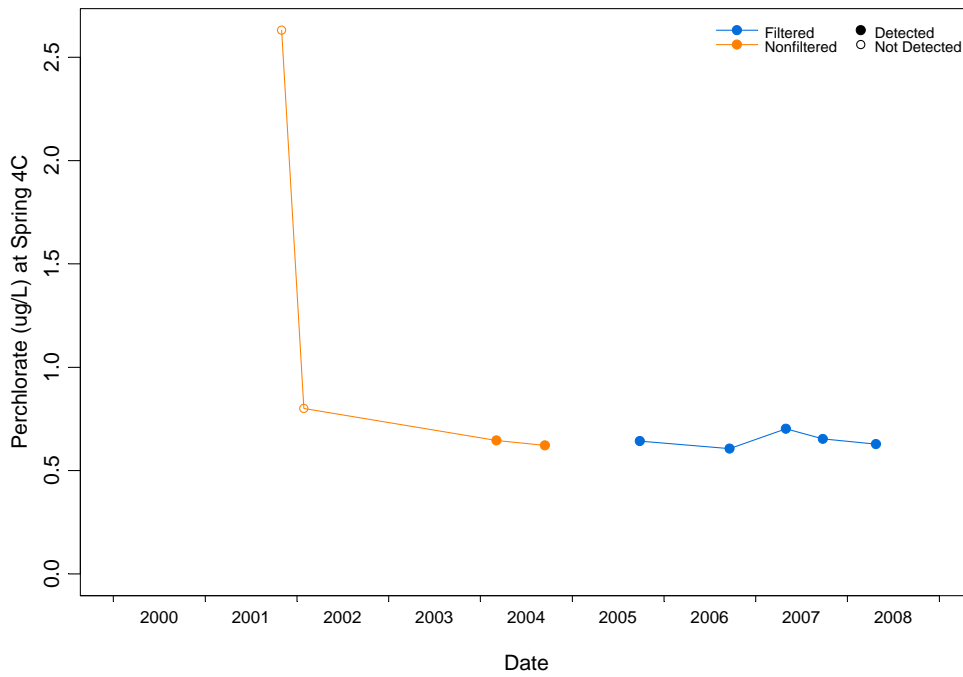

Figure D-2.2-181 Concentrations over time at Spring 4C for Perchlorate—analytical method before 2004 is EPA:314, analytical method post-2003 is SW-846:6850

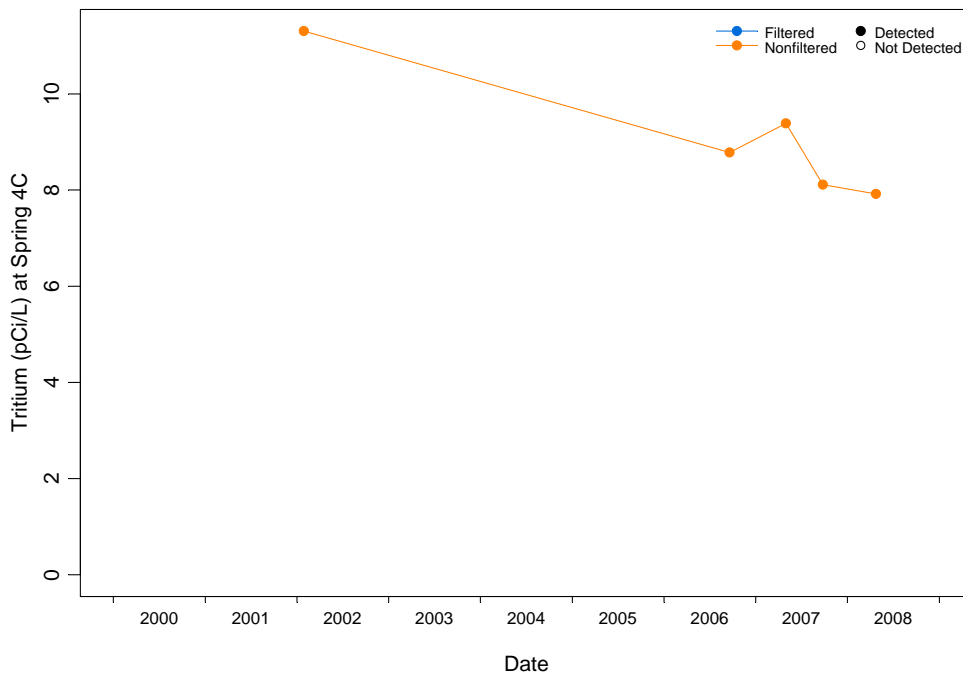

Figure D-2.2-182 Concentrations over time at Spring 4C for tritium

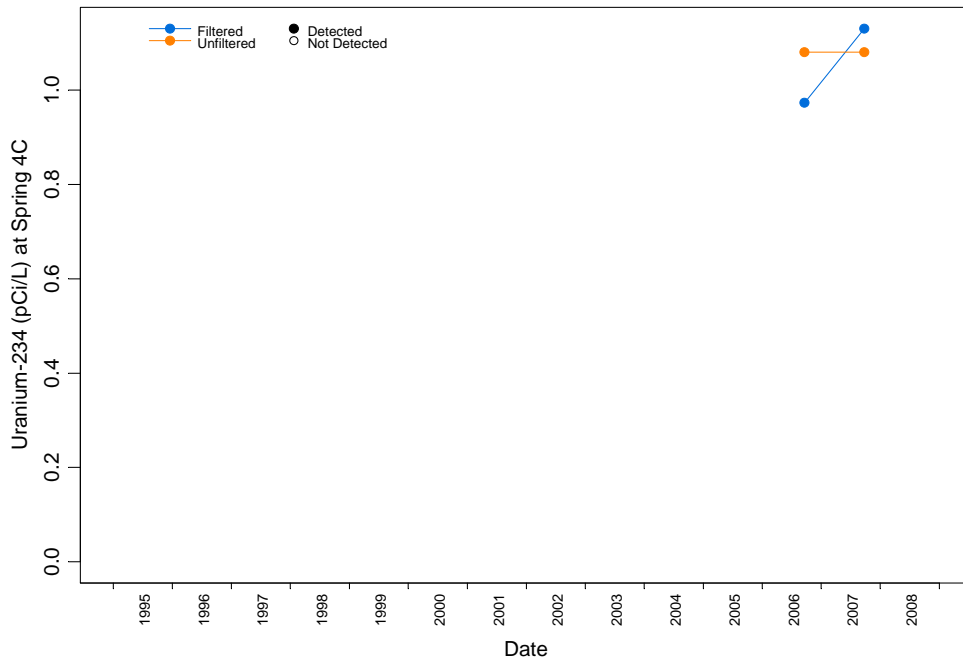

Figure D-2.2-183 Concentrations over time at Spring 4C for uranium-234

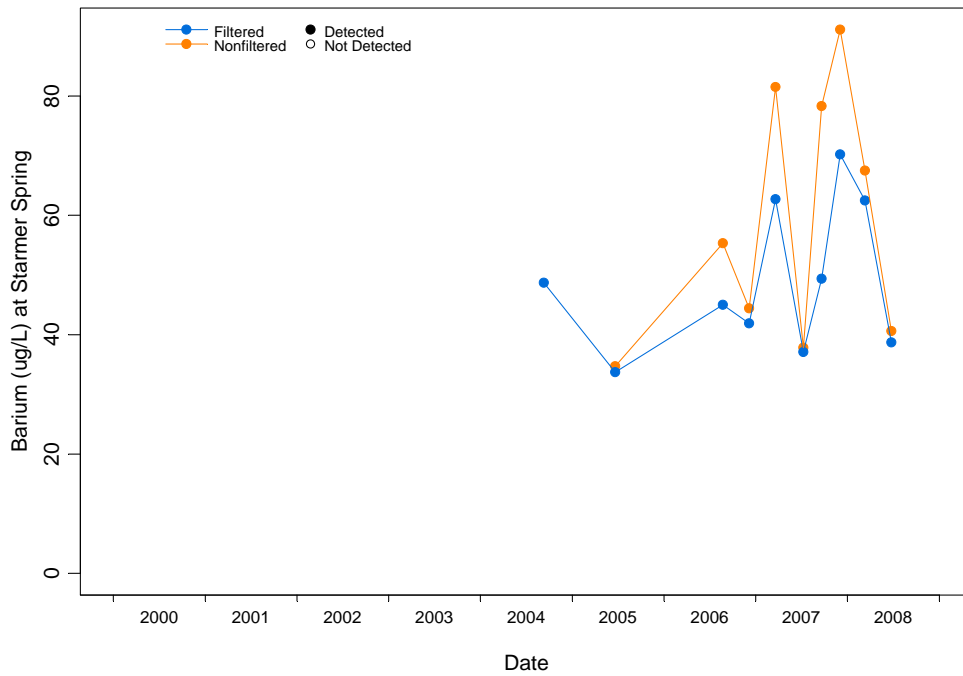

Figure D-2.2-184 Concentrations over time at Starmer Spring for barium

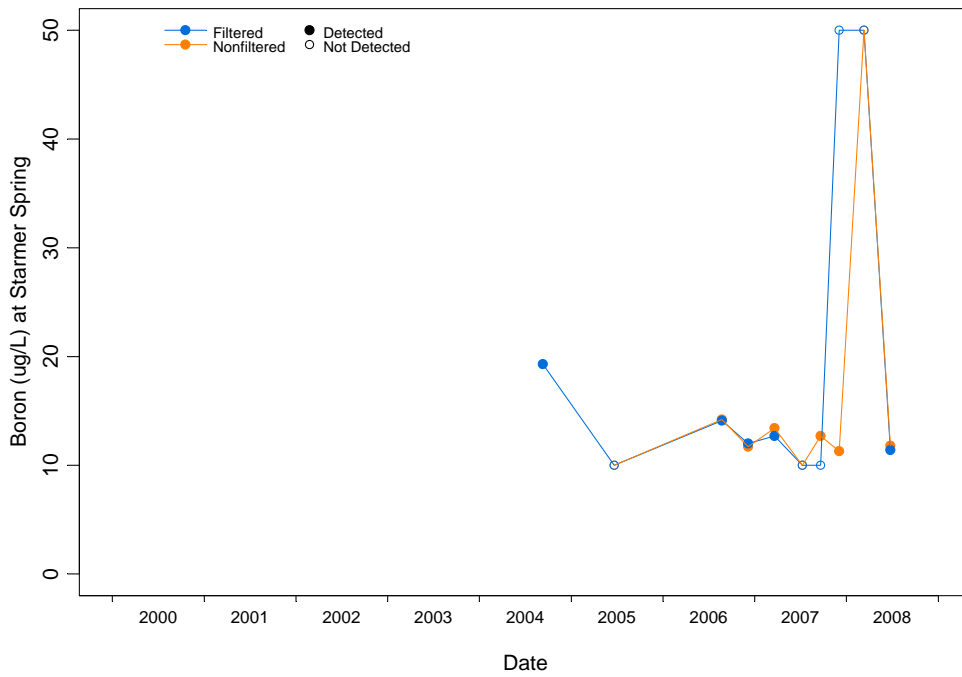

Figure D-2.2-185 Concentrations over time at Starmer Spring for boron

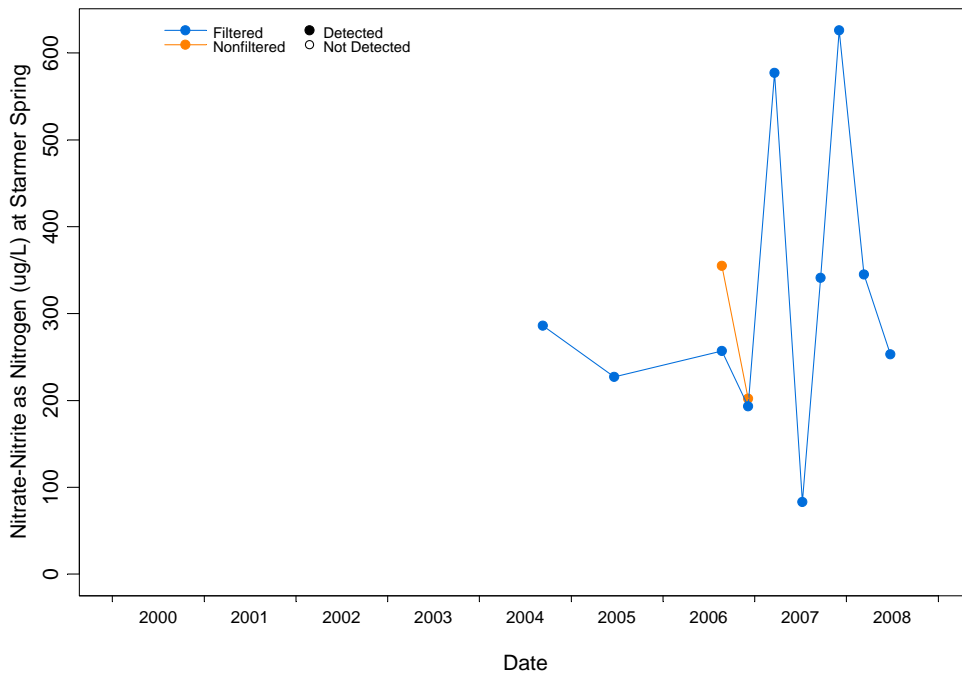

Figure D-2.2-186 Concentrations over time at Starmer Spring for nitrate-nitrite as nitrogen

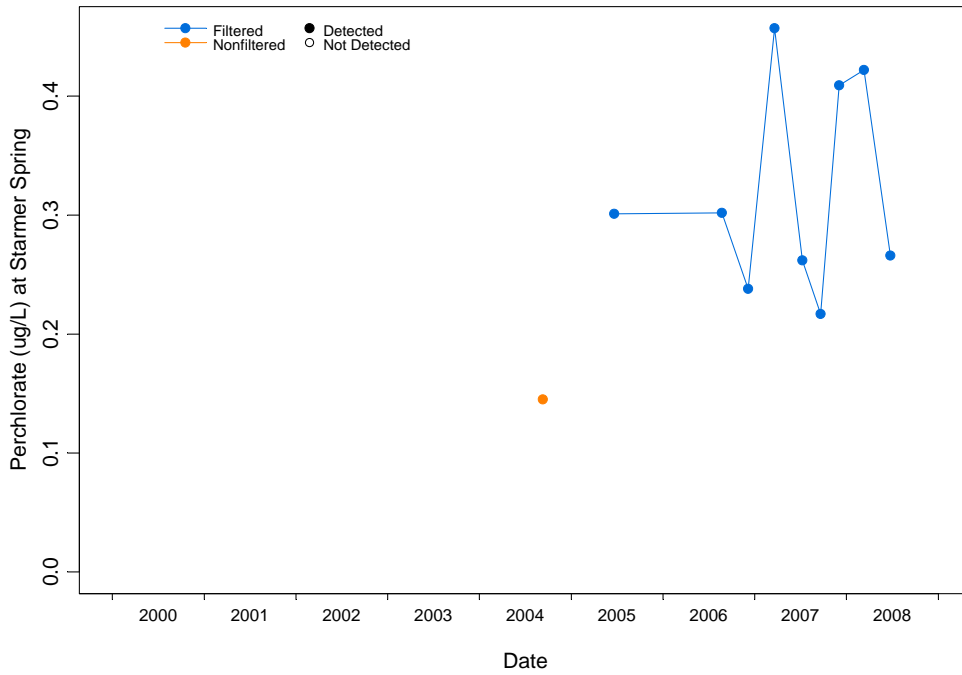

Figure D-2.2-187 Concentrations over time at Starmer Spring for perchlorate

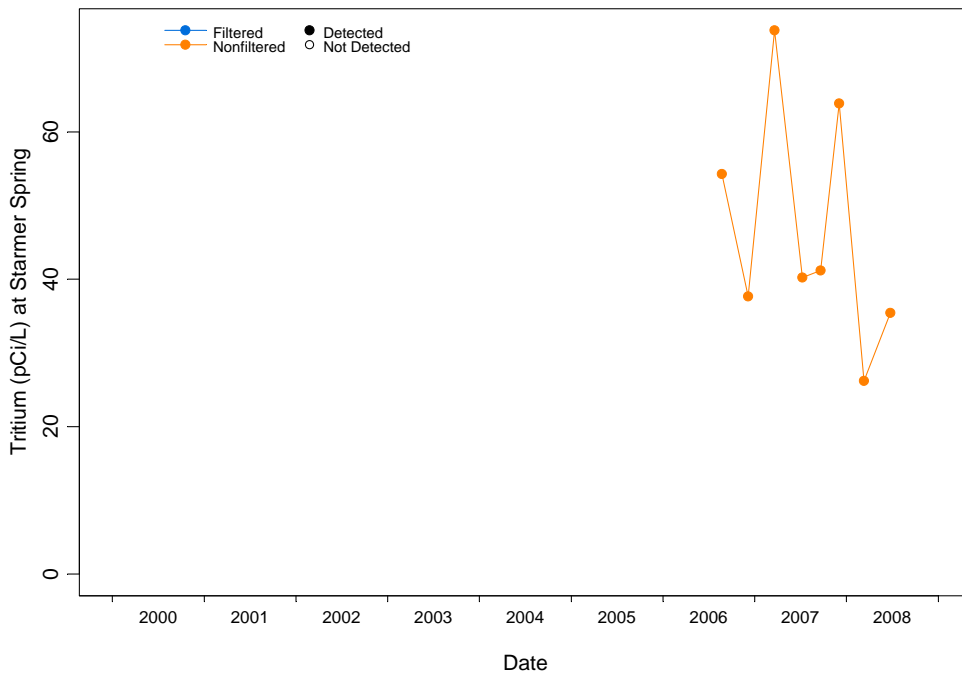

Figure D-2.2-188 Concentrations over time at Starmer Spring for tritium

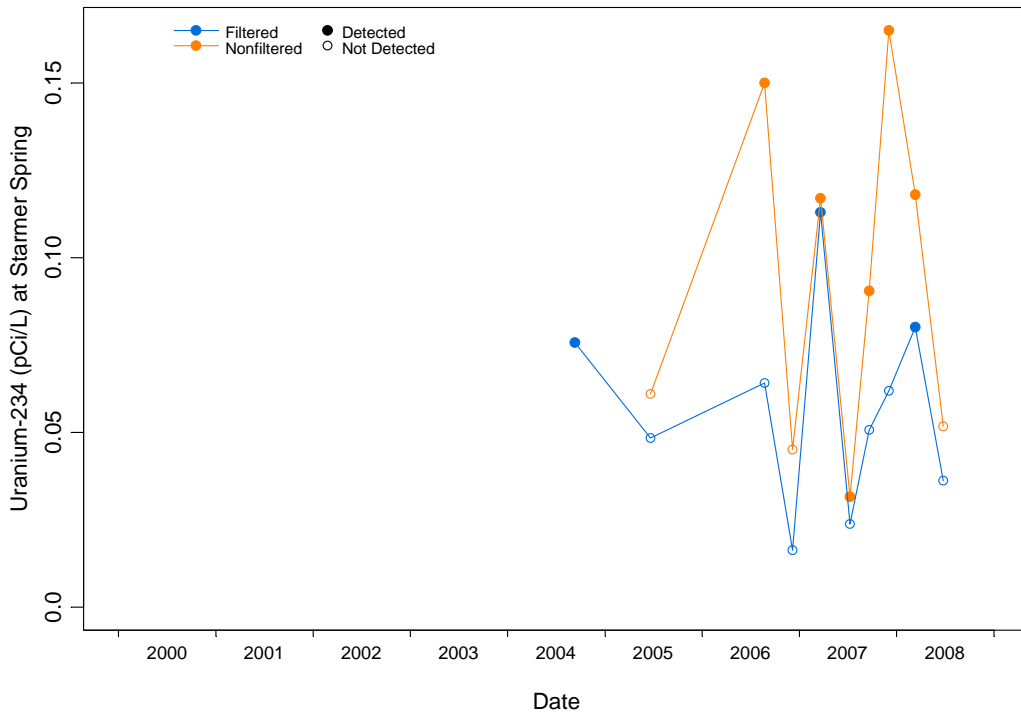

Figure D-2.2-189 Concentrations over time at Starmer Spring for uranium-234

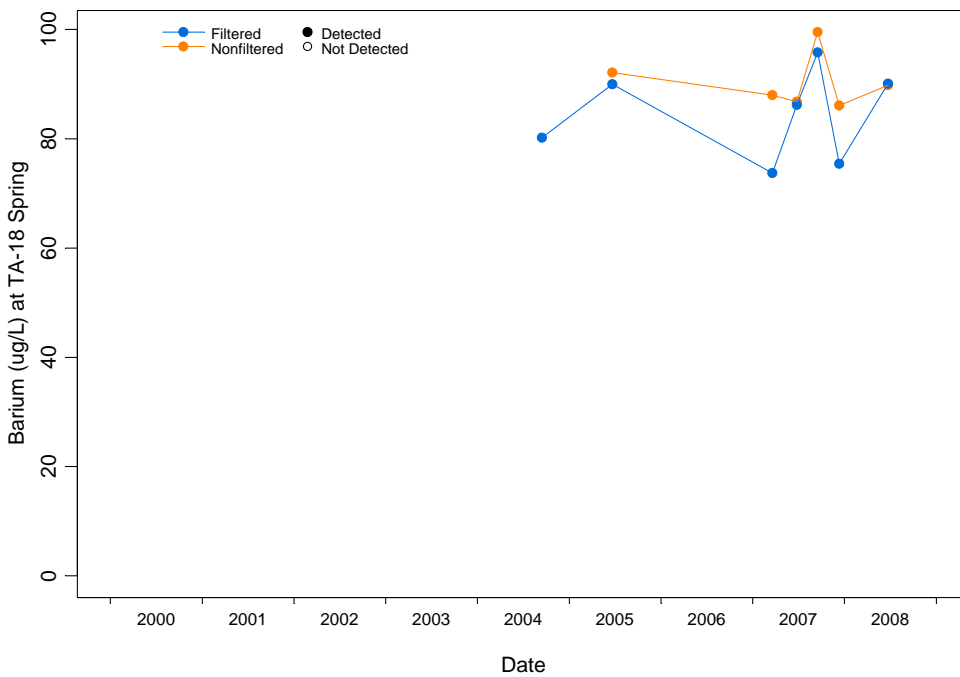

Figure D-2.2-190 Concentrations over time at TA-18 Spring for barium

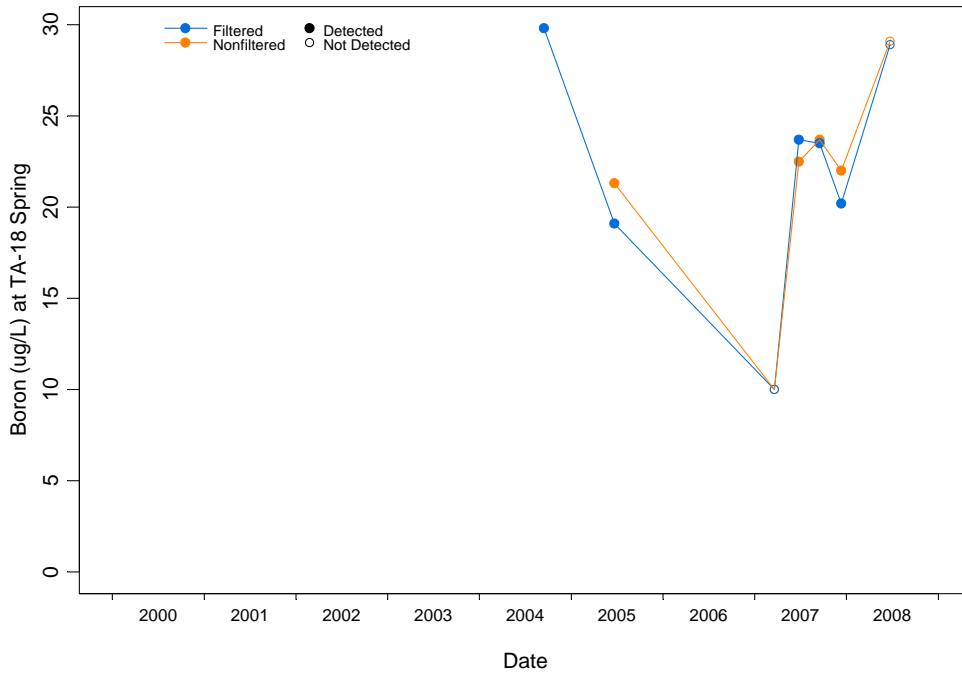

Figure D-2.2-191 Concentrations over time at TA-18 Spring for boron

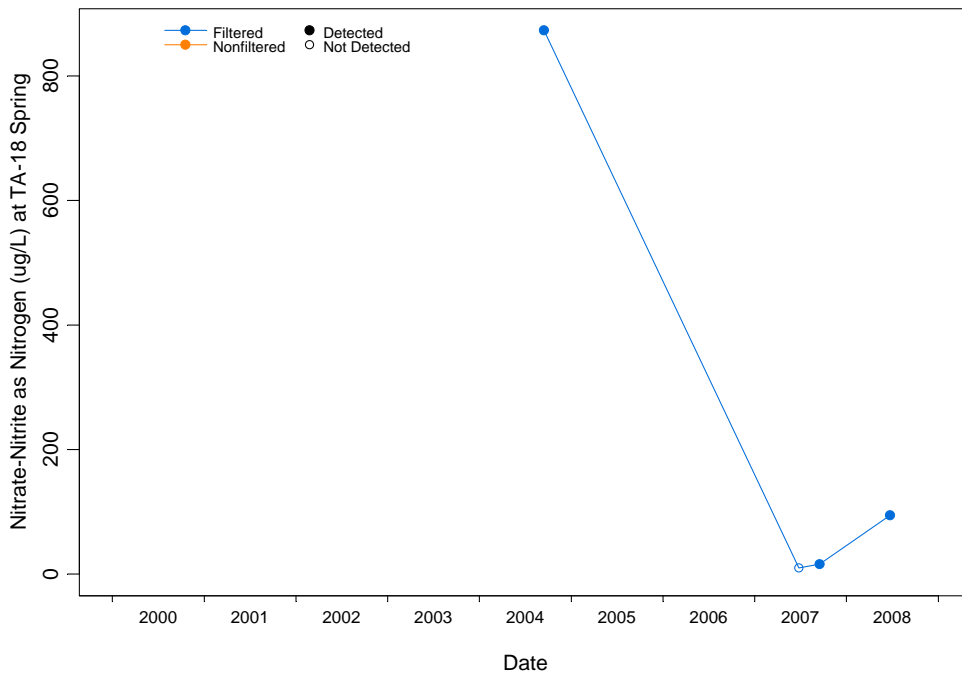

Figure D-2.2-192 Concentrations over time at TA-18 Spring for nitrate-nitrite as nitrogen

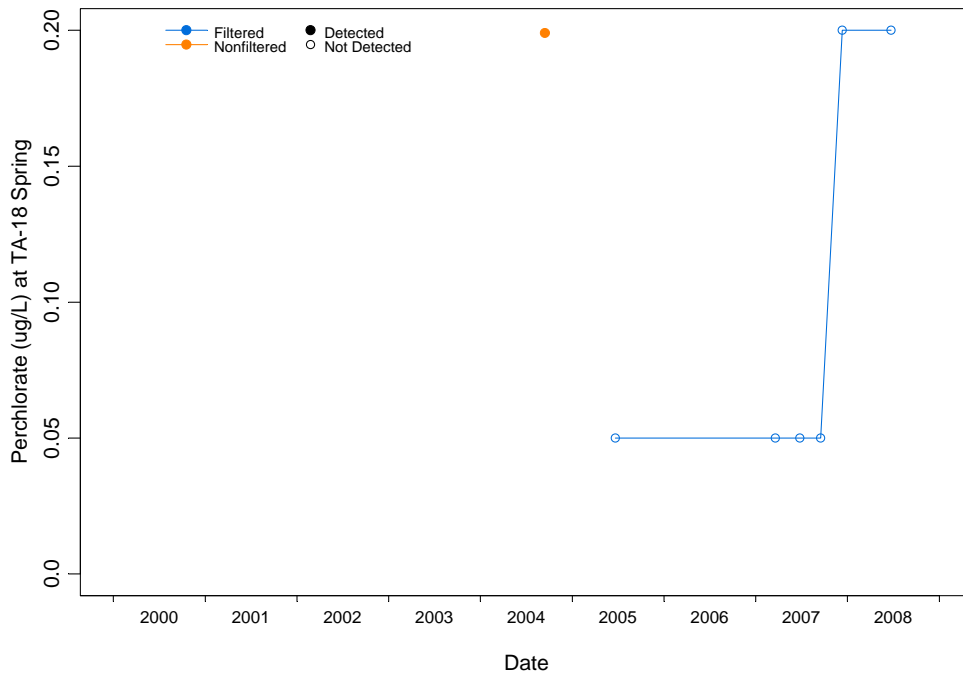

Figure D-2.2-193 Concentrations over time at TA-18 Spring for perchlorate

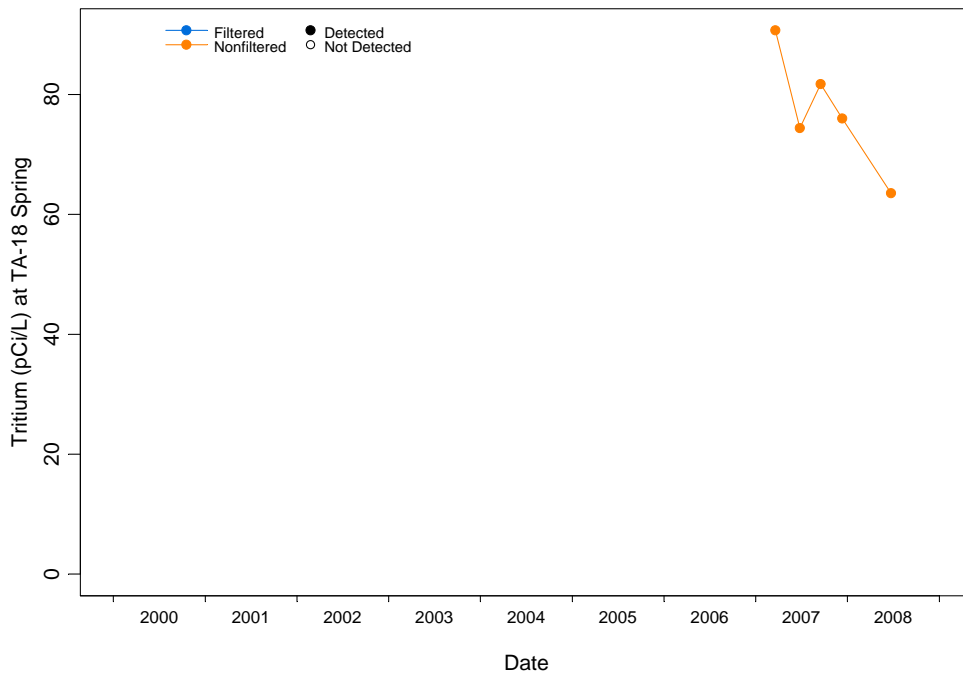

Figure D-2.2-194 Concentrations over time at TA-18 Spring for tritium

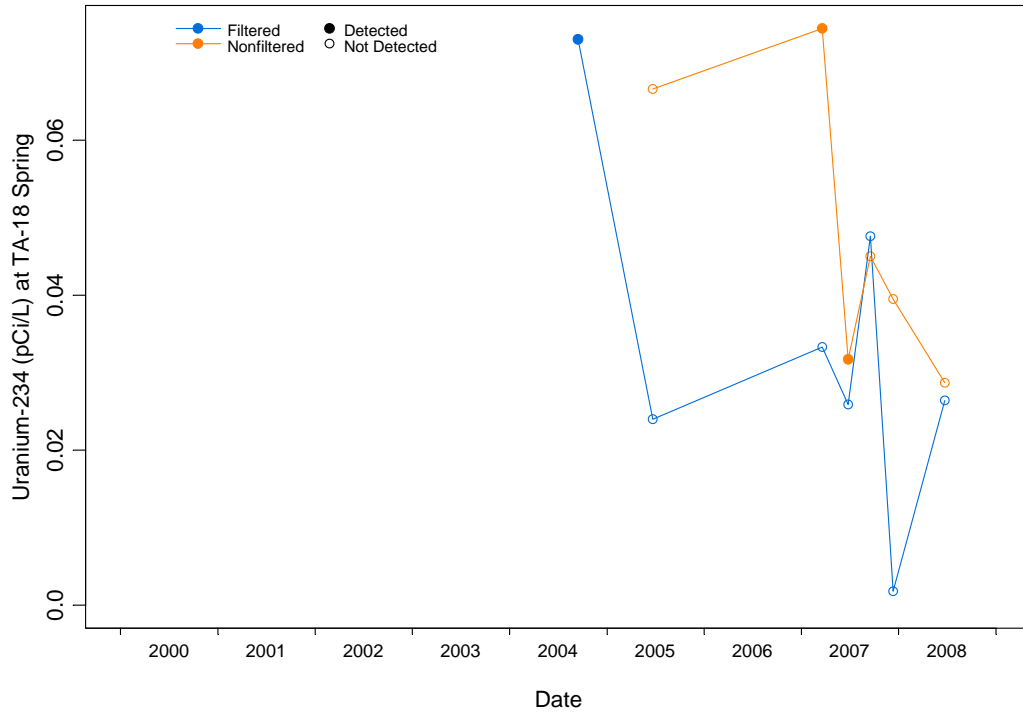

Figure D-2.2-195 Concentrations over time at TA-18 Spring for uranium-234

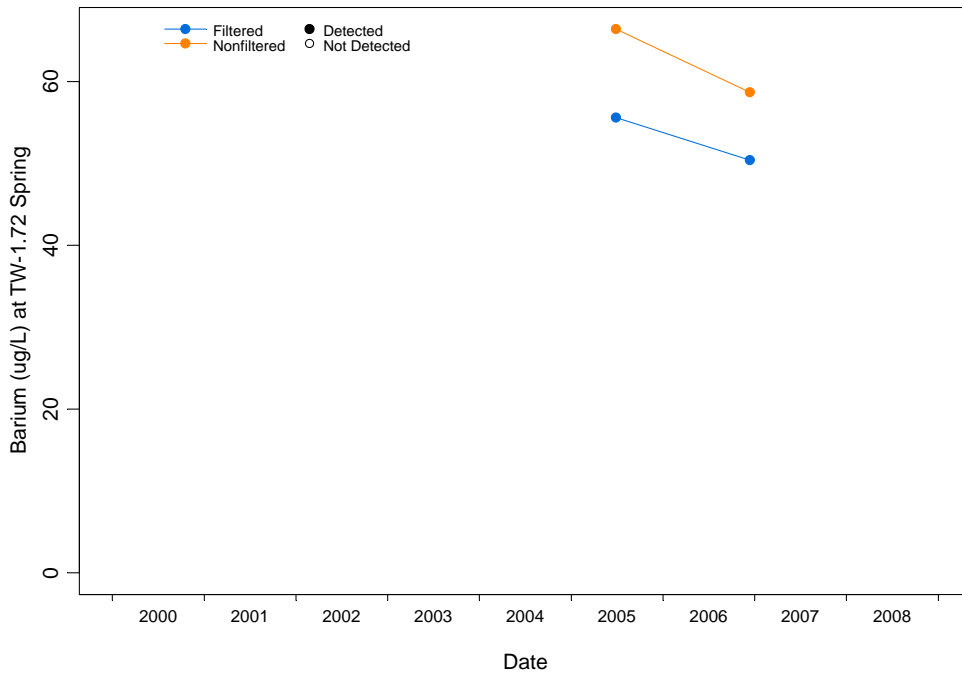

Figure D-2.2-196 Concentrations over time at TW-1.72 Spring for barium

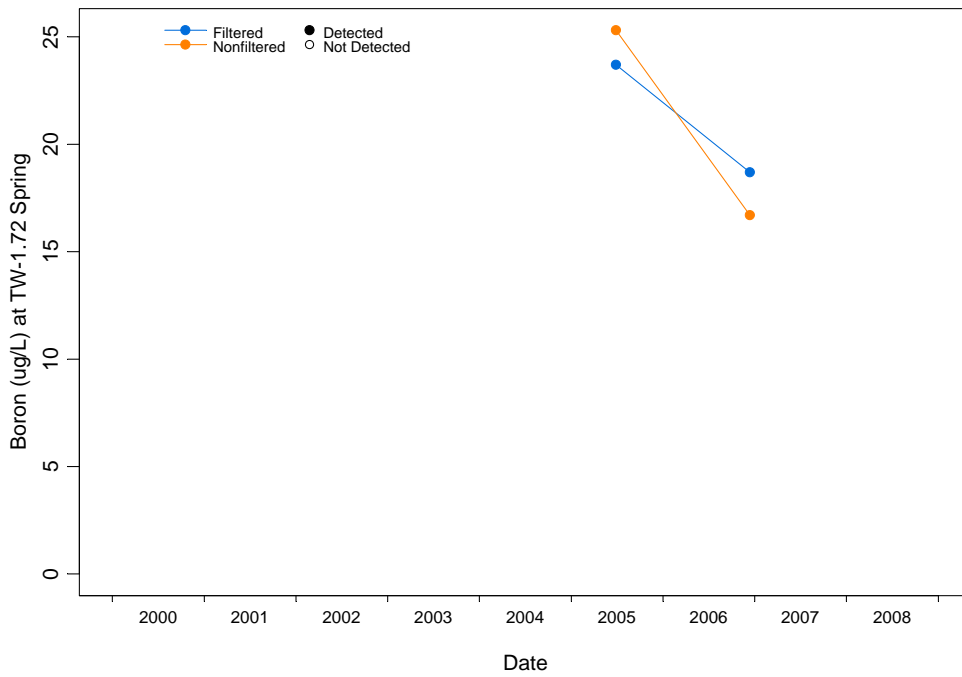

Figure D-2.2-197 Concentrations over time at TW-1.72 Spring for boron

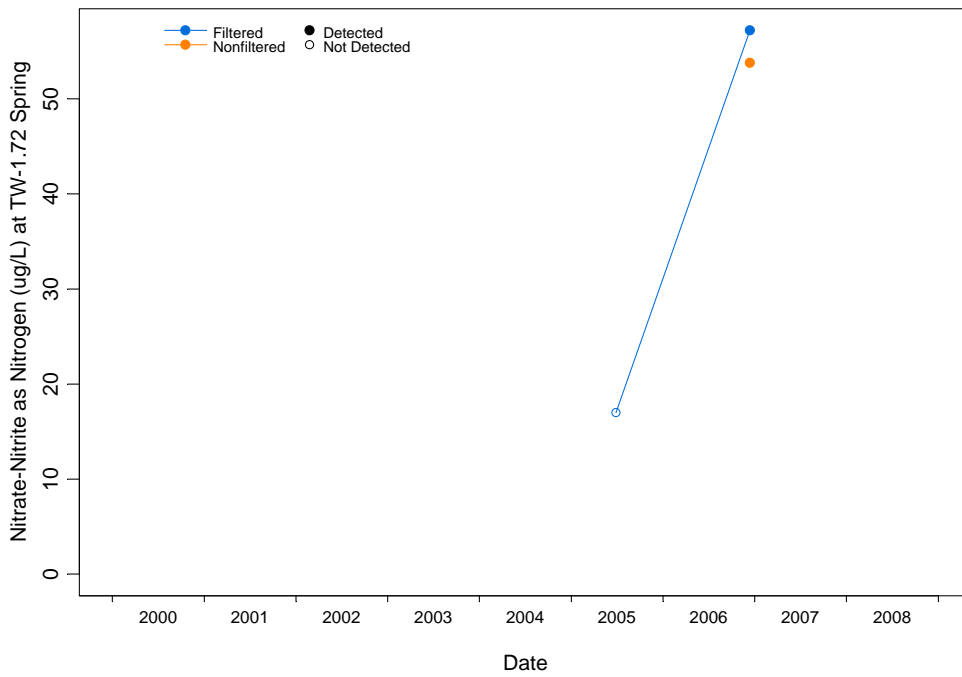

Figure D-2.2-198 Concentrations over time at TW-1.72 Spring for nitrate-nitrite as nitrogen

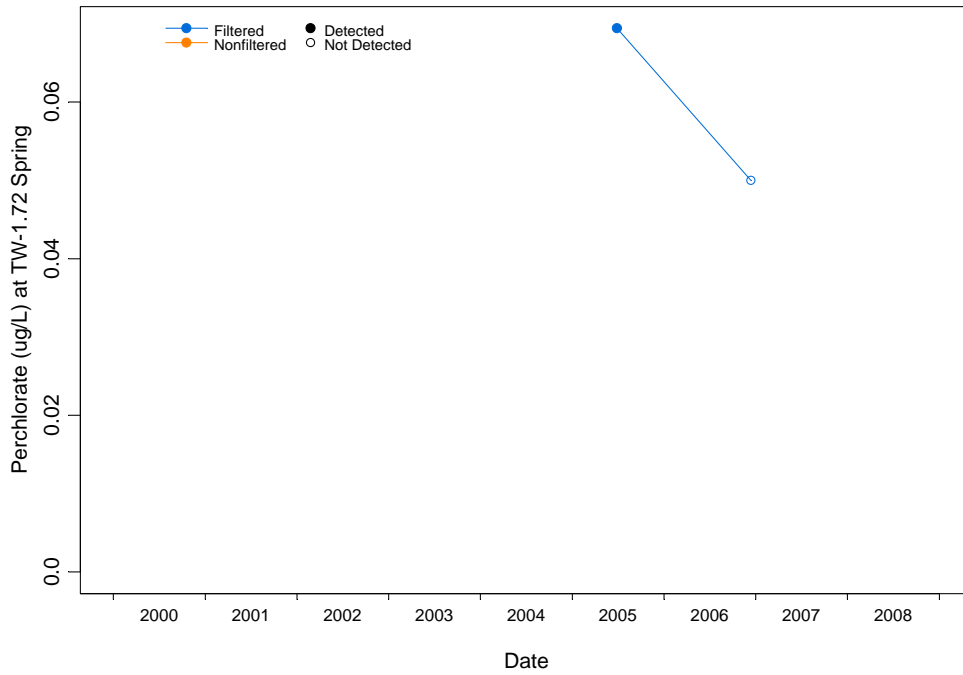

Figure D-2.2-199 Concentrations over time at TW-1.72 Spring for perchlorate

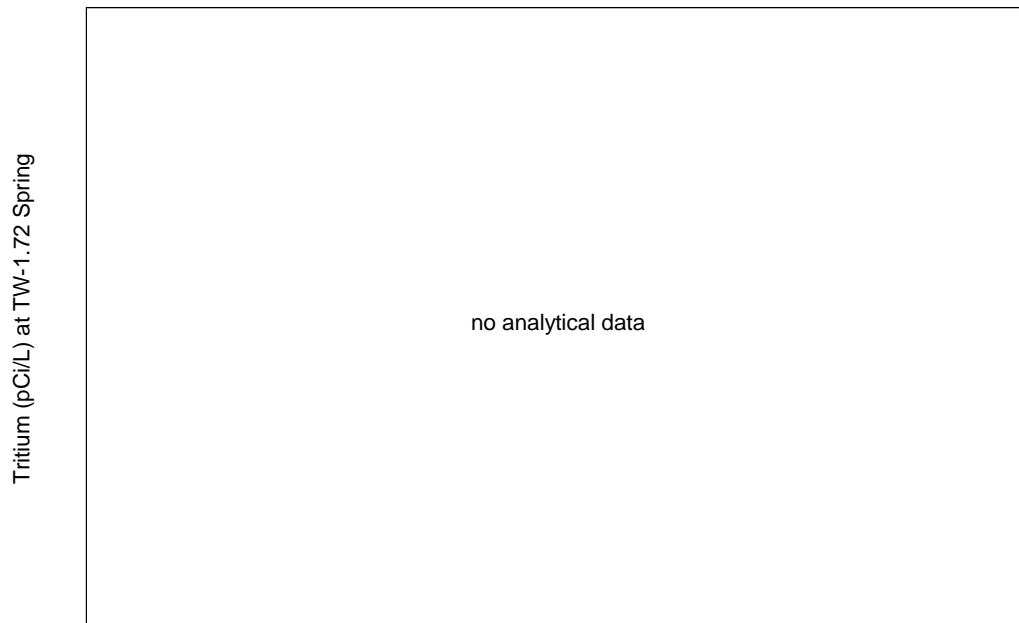

Figure D-2.2-200 Concentrations over time at TW-1.72 Spring for tritium - No analytical data

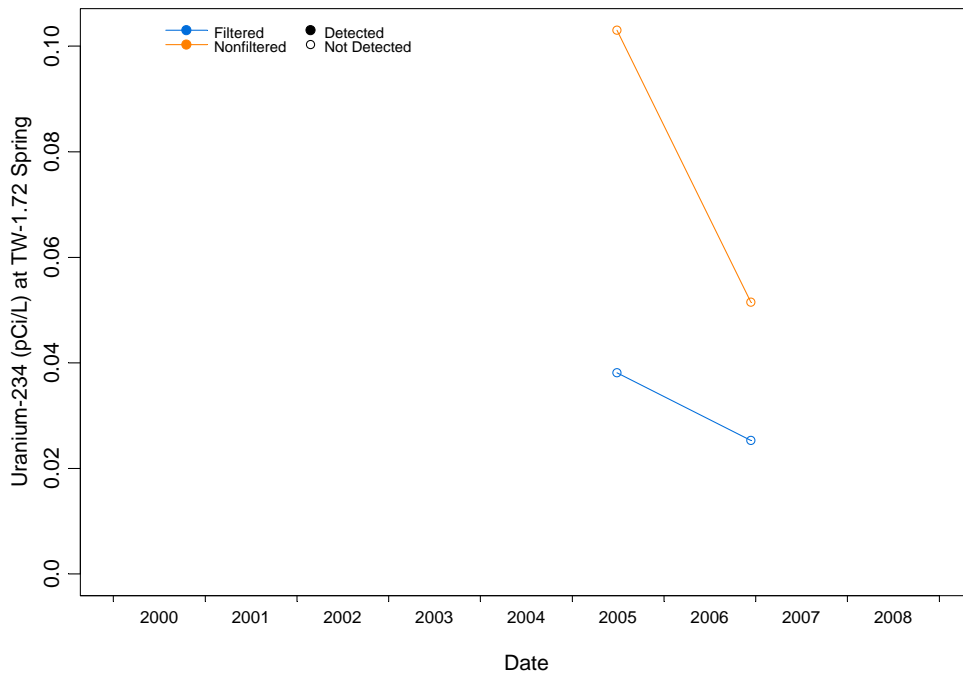

Figure D-2.2-201 Concentrations over time at TW-1.72 Spring for uranium-234

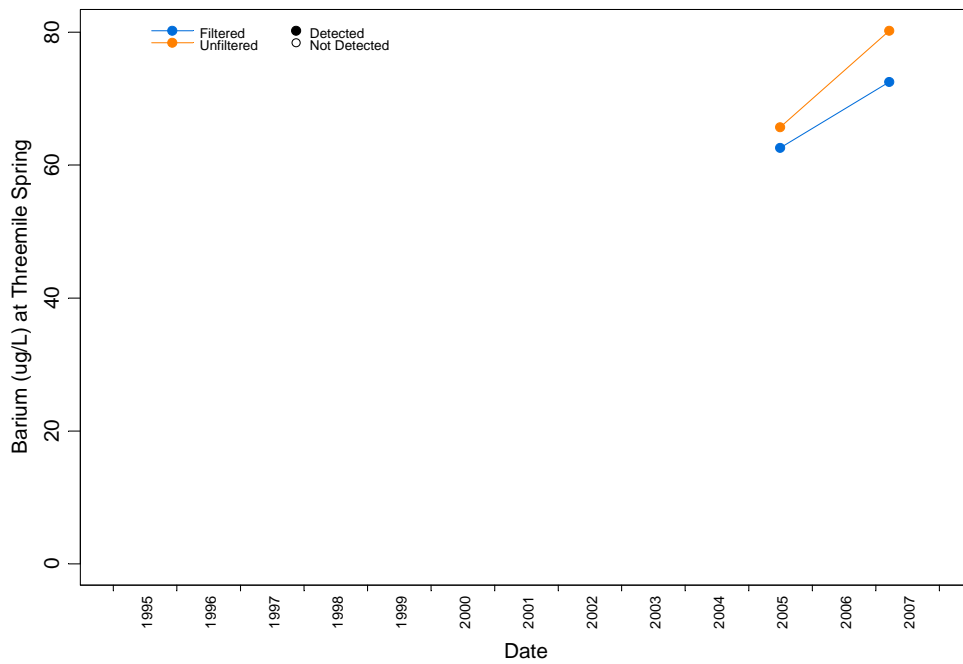

Figure D-2.2-202 Concentrations over time at Threemile Spring for barium

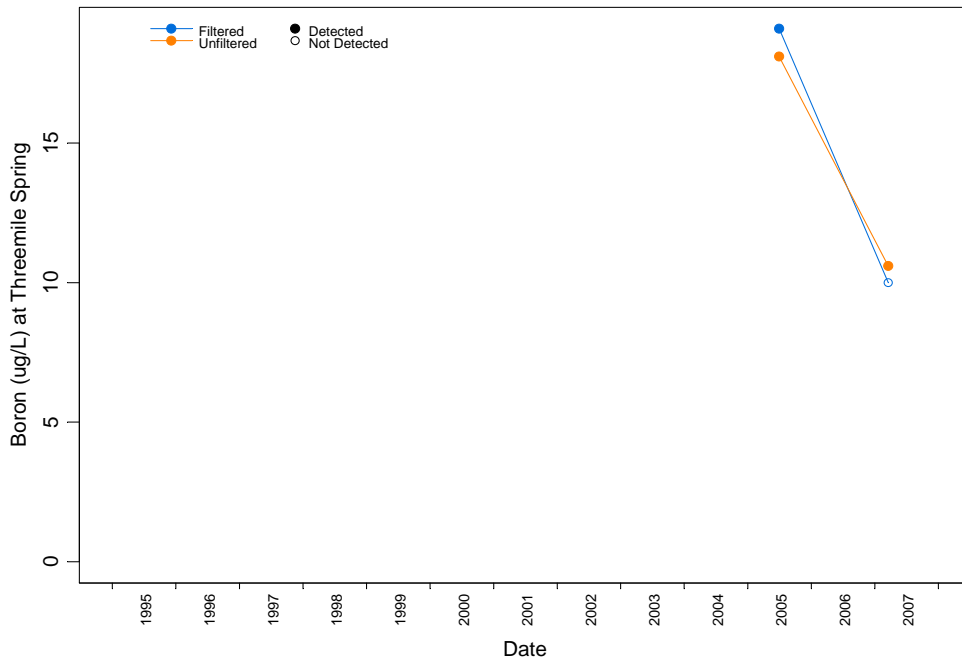

Figure D-2.2-203 Concentrations over time at Threemile Spring for boron

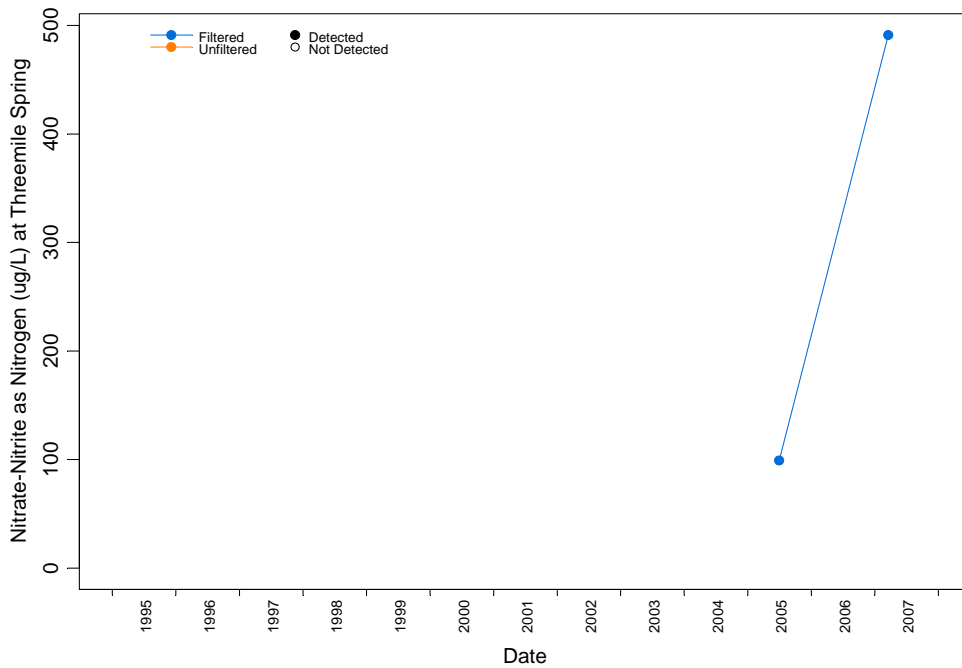

Figure D-2.2-204 Concentrations over time at Threemile Spring for nitrate-nitrite as nitrogen

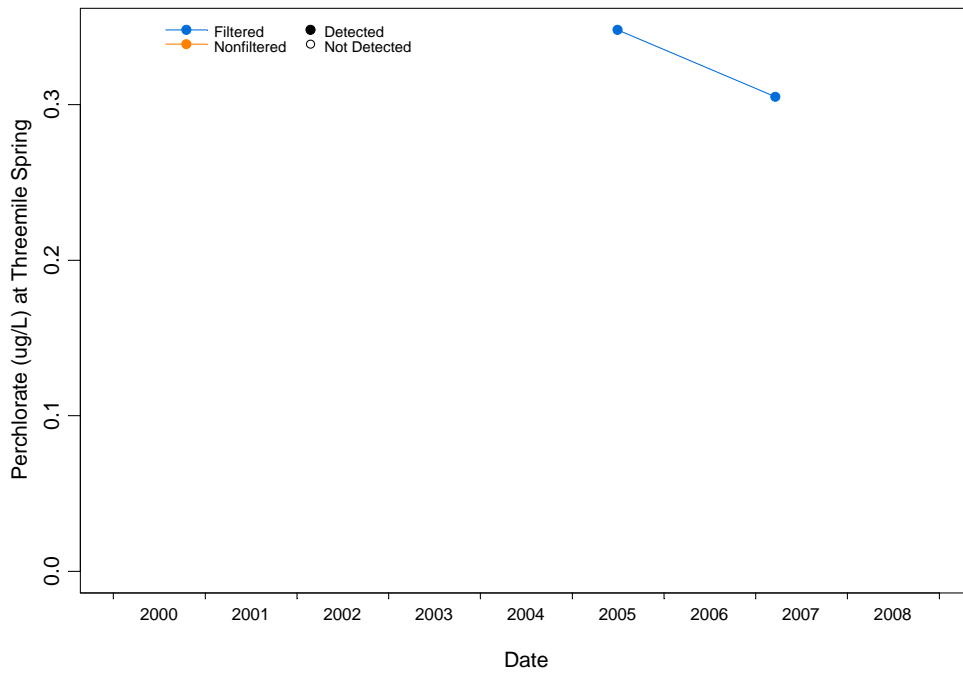

Figure D-2.2-205 Concentrations over time at Threemile Spring for perchlorate

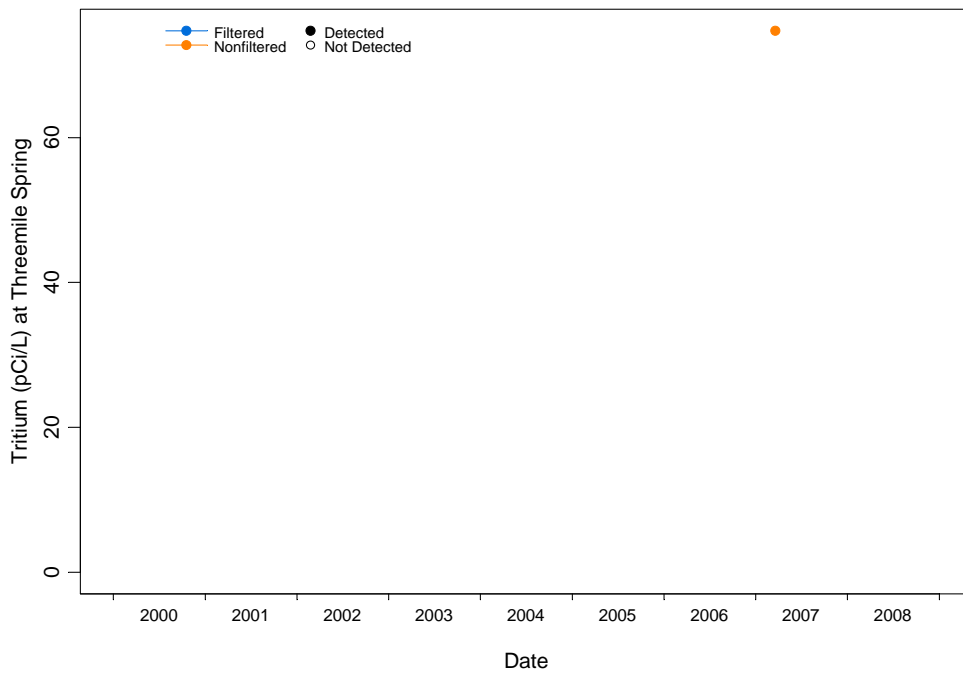

Figure D-2.2-206 Concentrations over time at Threemile Spring for tritium

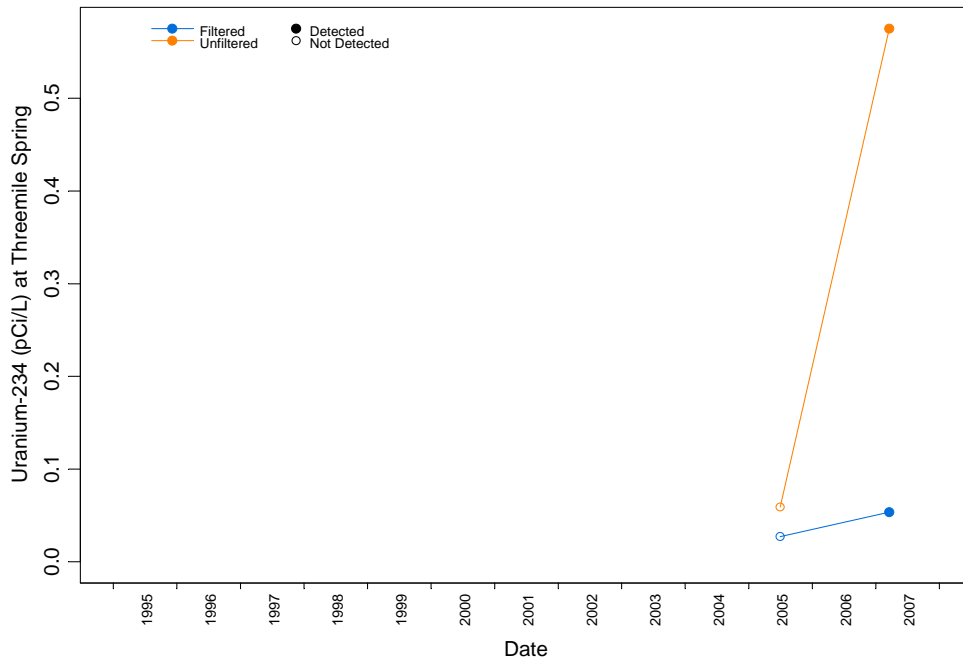

Figure D-2.2-207 Concentrations over time at Threemile Spring for uranium-234

Table D-1.2-1
Summary of Average Concentrations of Select Inorganic Chemicals in the Pajarito Watershed^a

Reach	Aluminum		Arsenic					Barium				Cadmium					Chromium			Copper				Cyanide (Total)																	
	Fine Facies Average	Coarse Facies Average	Fine Facies			Coarse Facies		Pre-Fire Fine Facies Average	Post-Fire Fine Facies Average	Pre-Fire Coarse Facies Average	Post-Fire Coarse Facies Average	Fine Facies			Coarse Facies		Fine Facies Average	Coarse Facies Average	Fine Facies			Coarse Facies Average	Pre-Fire Fine Facies			Post-Fire Fine Facies			Pre-Fire Coarse Facies			Post-Fire Coarse Facies									
			Upper Bound on Mean	Mid-Point of Range	Lower Bound on Mean	Upper Bound on Mean	Mid-Point of Range					Lower Bound on Mean	Upper Bound on Mean	Mid-Point of Range	Lower Bound on Mean	Upper Bound on Mean			Mid-Point of Range	Lower Bound on Mean	Upper Bound on Mean		Mid-Point of Range	Lower Bound on Mean	Upper Bound on Mean	Mid-Point of Range	Lower Bound on Mean	Upper Bound on Mean	Mid-Point of Range	Lower Bound on Mean	Upper Bound on Mean	Mid-Point of Range	Lower Bound on Mean	Upper Bound on Mean	Mid-Point of Range	Lower Bound on Mean	Upper Bound on Mean	Mid-Point of Range	Lower Bound on Mean		
BV	15400		3.98					127				0.4					10.5			11.2				0.82																	
AEN-1	11781	5185	3.94	3.94	3.94	2.43	2.43	2.43	134	n.d.	77	51	2.10	2.10	2.10	0.80	0.80	0.80	11.1	11.1	11.1	4.2	9.6	9.6	9.6	3.4	-	-	-	-	-	-	-	-	-	-	-	-	-	-	-
AES-1	13745	8085	3.28	3.28	3.28	4.41	4.41	4.41	142	122	99	90	^b	-	-	-	-	-	9.9	9.9	9.9	6.5	-	-	-	-	-	-	-	-	-	-	-	-	-	-	-	-	-	-	
AW-1	16800	7862	7.92	7.92	7.92	4.66	4.66	4.66	297	n.d. ^c	472	n.d.	1.65	1.25	0.85	0.44	0.26	0.08	23.8	23.5	23.2	7.6	18.5	18.1	17.8	9.1	-	-	-	-	-	-	-	-	-	-	-	-	-	-	-
PA-0	-	-	-	-	-	-	-	-	122	157	n.d.	84	-	-	-	-	-	-	-	-	-	-	-	-	-	-	0.28	0.14	0.00	0.76	0.74	0.71	n.d.	n.d.	n.d.	0.25	0.22	0.18			
PA-1E	-	-	2.53	2.53	2.53	2.46	2.46	2.46	-	-	-	-	0.92	0.91	0.91	0.62	0.62	0.62	9.1	9.1	9.1	5.3	17.7	17.7	17.7	5.0	-	-	-	-	-	-	-	-	-	-	-	-	-	-	
PA-1W	10584	4383	-	-	-	-	-	-	113	71	n.d.	38	-	-	-	-	-	-	9.1	9.1	9.1	4.2	-	-	-	-	-	-	-	-	-	-	-	-	-	-	-	-	-	-	
PA-2W	8499	3873	-	-	-	-	-	-	121	153	69	25	0.71	0.69	0.67	0.49	0.39	0.30	9.8	9.5	9.3	4.1	26.1	25.1	24.2	4.4	0.44	0.22	0.00	0.52	0.49	0.45	0.26	0.13	0.00	0.27	0.13	0.00			
PA-3E	10431	3100	-	-	-	-	-	-	99	244	33	37	0.44	0.30	0.15	0.52	0.26	0.00	9.4	9.4	9.4	4.1	10.6	10.6	10.6	2.3	0.29	0.17	0.05	1.19	1.19	1.19	0.25	0.13	0.00	0.25	0.12	0.00			
PA-4	15820	4123	3.91	3.91	3.91	1.41	1.41	1.41	149	646	27	89	0.29	0.23	0.17	0.24	0.14	0.05	10.9	10.9	10.9	4.1	14.4	14.4	14.4	4.1	0.44	0.27	0.10	1.96	1.96	1.96	0.24	0.12	0.00	n.d.	n.d.	n.d.			
PA-4E	-	-	-	-	-	n.d. ^c	n.d.	n.d.	95	180	n.d.	n.d.	-	-	-	-	-	-	-	-	-	-	-	-	-	-	0.61	0.30	0.00	0.99	0.99	0.99	n.d.	n.d.	n.d.	n.d.	n.d.	n.d.			
PA-5W	13410	5838	2.80	2.80	2.80	1.33	1.33	1.33	87	514	45	105	0.32	0.32	0.32	0.24	0.18	0.11	9.4	9.4	9.4	4.4	9.7	9.7	9.7	4.5	0.26	0.13	0.00	1.02	1.02	1.02	0.26	0.13	0.00	0.08	0.08	0.08			
PAS-1E	13650	8258	3.08	3.08	3.08	3.90	3.90	3.90	136	197	92	50	0.42	0.30	0.17	3.02	1.68	0.34	11.3	11.3	11.3	7.7	-	-	-	-	0.21	0.13	0.06	0.96	0.96	0.96	0.20	0.12	0.03	0.26	0.13	0.00			
PAS-2W	-	-	3.36	3.36	3.36	3.70	3.70	3.70	180	n.d.	122	71	0.39	0.23	0.08	0.41	0.41	0.41	-	-	-	-	-	-	-	-	-	-	-	-	-	-	-	-	-	-	-	-			
TH-1C	-	-	2.60	2.60	2.60	1.38	1.13	0.87	94	132	25	29	-	-	-	-	-	-	-	-	-	-	-	-	-	n.d.	n.d.	n.d.	n.d.	n.d.	n.d.	n.d.	n.d.	n.d.	n.d.	n.d.	n.d.				
TH-1E	18313	7580	4.14	4.14	4.14	1.71	1.71	1.71	173	147	40	50	-	-	-	-	-	-	12.2	12.2	12.2	4.7	11.0	11.0	11.0	3.3	-	-	-	-	-	-	-	-	-	-	-	-	-		
TH-3	-	-	-	-	-	n.d.	n.d.	n.d.	-	-	-	-	-	-	-	-	-	-	-	-	-	-	-	-	-	-	-	-	-	-	-	-	-	-	-	-	-				
THM-1	-	-	-	-	-	-	-	-	81	131	29	22	0.45	0.26	0.08	0.51	0.25	0.00	-	-	-	-	25.6	25.6	25.6	14.8	-	-	-	-	-	-	-	-	-	-	-	-	-		
THS-1E	-	-	-	-	-	-	-	-	93	n.d.	23	23	-	-	-	-	-	-	-	-	-	-	13.0	13.0	13.0	2.9	-	-	-	-	-	-	-	-	-	-	-	-	-		
THS-1W	-	-	-	-	-	-	-	-	-	-	-	-	-	-	-	-	-	-	-	-	-	-	12.1	12.1	12.1	3.5	n.d.	n.d.	n.d.	n.d.	n.d.	n.d.	n.d.	n.d.	n.d.	n.d.	n.d.	n.d.			
THW-1	14238	9555	3.08	3.08	3.08	1.91	1.91	1.91	150	138	112	39	0.33	0.33	0.33	0.17	0.17	0.17	8.5	8.5	8.5	4.7	9.4	9.4	9.4	3.5	n.d.	n.d.	n.d.	n.d.	n.d.	n.d.	n.d.	n.d.	n.d.	n.d.	n.d.	n.d.			
TW-1E	-	-	-	-	-	-	-	-	185	n.d.	71	33	-	-	-	-	-	-	-	-	-	-	-	-	-	-	-	-	-	-	-	-	-	-	-	-	-				
TW-1W	-	-	-	-	-	-	-	-	85	164	28	34	0.28	0.28	0.28	0.14	0.14	0.14	-	-	-	-	-	-	-	-	n.d.	n.d.	n.d.	n.d.	n.d.	n.d.	n.d.	n.d.	n.d.	n.d.	n.d.				
TW-2E	-	-	-	-	-	-	-	-	73	101	27	25	0.41	0.41	0.41	0.67	0.34	0.00	-	-	-	-	-	-	-	-	-	-	-	-	-	-	-	-	-	-					

Table D-1.2-1 (continued)

Reach	Aluminum		Arsenic						Barium				Cadmium						Chromium				Copper				Cyanide (Total)											
	Fine Facies	Coarse Facies	Fine Facies			Coarse Facies			Pre-Fire Fine Facies	Post-Fire Fine Facies	Pre-Fire Coarse Facies	Post-Fire Coarse Facies	Fine Facies			Coarse Facies			Fine Facies	Coarse Facies	Fine Facies	Coarse Facies	Fine Facies	Coarse Facies	Pre-Fire Fine Facies			Post-Fire Fine Facies			Pre-Fire Coarse Facies			Post-Fire Coarse Facies				
			Upper Bound on Mean	Mid-Point of Range	Lower Bound on Mean	Upper Bound on Mean	Mid-Point of Range	Lower Bound on Mean					Average	Average	Average	Average	Upper Bound on Mean	Mid-Point of Range							Lower Bound on Mean	Upper Bound on Mean	Mid-Point of Range	Lower Bound on Mean	Upper Bound on Mean	Mid-Point of Range	Lower Bound on Mean	Upper Bound on Mean	Mid-Point of Range	Lower Bound on Mean	Upper Bound on Mean	Mid-Point of Range	Lower Bound on Mean	Upper Bound on Mean
TW-3E	-	-	3.71	3.71	3.71	2.05	2.05	2.05	-	-	-	-	0.29	0.29	0.29	0.18	0.18	0.18	-	-	-	-	-	-	-	0.28	0.18	0.07	1.35	1.35	1.35	n.d.	n.d.	n.d.	0.29	0.20	0.12	
TW-4E	-	-	-	-	-	-	-	-	-	-	-	-	-	-	-	-	-	-	-	-	-	-	-	-	-	-	-	-	-	-	-	-	-	-	-	-		
TW-4W	-	-	-	-	-	-	-	-	-	-	-	-	-	-	-	-	-	-	-	-	-	-	-	-	-	-	-	-	-	-	-	-	-	-	-	-		
TWN-1E	-	-	-	-	-	-	-	-	75	192	27	42	0.31	0.31	0.31	0.34	0.23	0.12	-	-	-	-	8.7	8.7	8.7	4.8	0.27	0.20	0.13	0.68	0.68	0.68	0.27	0.13	0.00	0.40	0.33	0.27
TWN-1W	-	-	3.48	3.48	3.48	1.72	1.72	1.72	82	102	26	30	-	-	-	-	-	-	8.2	8.2	8.2	2.8	6.0	6.0	6.0	2.0	-	-	-	-	-	-	-	-	-	-	-	
TWSE-1E	8059	3697	2.98	2.98	2.98	1.26	1.26	1.26	94	151	30	16	-	-	-	-	-	-	6.7	6.7	6.7	3.1	7.8	7.8	7.8	2.1	-	-	-	-	-	-	-	-	-	-	-	
TWSE-1W	15311	4830	3.30	3.30	3.30	2.35	2.35	2.35	133	139	45	n.d.	-	-	-	-	-	-	11.6	11.6	11.6	3.5	31.3	31.3	31.3	5.2	1.22	1.21	1.19	1.14	1.14	1.14	0.71	0.71	0.71	n.d.	n.d.	n.d.
TWSW-1E	8130	3715	3.23	3.23	3.23	3.35	2.86	2.38	102	213	81	9	0.22	0.15	0.08	0.61	0.30	0.00	7.1	7.1	7.1	3.1	7.7	7.7	7.7	2.7	0.51	0.25	0.00	0.65	0.65	0.65	0.27	0.13	0.00	0.31	0.16	0.00
TWSW-1W	13384	3920	4.17	4.17	4.17	2.07	2.07	2.07	134	117	n.d.	23	-	-	-	-	-	-	9.3	9.3	9.3	2.9	-	-	-	-	0.35	0.23	0.12	0.30	0.23	0.17	n.d.	n.d.	n.d.	0.25	0.13	0.00

Table D-1.2-1 (continued)

Reach	Iron		Lead		Manganese				Mercury						Perchlorate						Selenium						Silver		Thallium		Uranium (Total)	
	Fine Facies	Coarse Facies	Fine Facies	Coarse Facies	Pre-Fire Fine Facies	Post-Fire Fine Facies	Pre-Fire Coarse Facies	Post-Fire Coarse Facies	Fine Facies			Coarse Facies			Fine Facies			Coarse Facies			Fine Facies			Coarse Facies			Fine Facies	Coarse Facies	Fine Facies	Coarse Facies	Fine Facies	Coarse Facies
	Average	Average	Average	Average	Average	Average	Average	Average	Upper Bound on Mean	Mid-Point of Range	Lower Bound on Mean	Upper Bound on Mean	Mid-Point of Range	Lower Bound on Mean	Upper Bound on Mean	Mid-Point of Range	Lower Bound on Mean	Upper Bound on Mean	Mid-Point of Range	Lower Bound on Mean	Upper Bound on Mean	Mid-Point of Range	Lower Bound on Mean	Upper Bound on Mean	Mid-Point of Range	Lower Bound on Mean	Average	Average	Average	Average	Average	Average
BV	13800		19.7		543				0.10						no BV						0.30						1.0		0.73		6.99	
AEN-1	11469	7770	14.8	9.2	461	n.d.	362	477	0.27	0.27	0.27	0.07	0.06	0.06	0.002	0.001	0.000	0.002	0.001	0.000	1.59	0.85	0.11	1.74	0.87	0.00	2.2	0.6	1.02	0.40	5.19	3.55
AES-1	12638	12600	12.6	19.4	429	455	791	618	-	-	-	-	-	-	-	-	-	-	-	-	-	-	-	-	-	-	-	-	-	-	-	
AW-1	15094	10628	36.2	19.9	431	n.d.	270	n.d.	0.24	0.24	0.24	0.03	0.03	0.03	n.d.	n.d.	n.d.	n.d.	n.d.	n.d.	3.45	1.90	0.34	1.86	1.22	0.57	30.6	24.6	-	-	4.31	2.61
PA-0	-	-	-	-	469	548	n.d.	422	-	-	-	-	-	-	0.002	0.001	0.000	0.002	0.001	0.000	0.85	0.74	0.62	2.12	1.50	0.88	-	-	-	-	-	
PA-1E	-	-	13.2	10.7	408	405	685	306	-	-	-	-	-	-	0.002	0.001	0.000	0.002	0.001	0.000	0.96	0.69	0.42	1.57	0.79	0.00	3.5	0.4	-	-	-	
PA-1W	-	-	-	-	-	-	-	-	-	-	-	-	-	-	0.002	0.001	0.000	0.002	0.001	0.000	-	-	-	-	-	-	-	-	-	-	-	
PA-2W	11140	6307	-	-	383	549	609	119	-	-	-	-	-	-	0.002	0.001	0.000	0.002	0.001	0.000	1.30	0.81	0.32	1.60	0.80	0.00	2.8	0.6	-	-	4.97	3.22
PA-3E	-	-	26.1	10.7	332	847	304	340	-	-	-	-	-	-	0.002	0.001	0.000	0.002	0.001	0.000	1.80	0.97	0.14	1.56	0.78	0.00	-	-	-	-	-	
PA-4	16343	8927	20.8	6.9	571	2045	152	251	-	-	-	-	-	-	-	-	-	-	-	-	0.73	0.70	0.66	1.80	1.71	1.63	0.5	0.2	-	-	-	
PA-4E	-	-	-	-	-	-	-	-	-	-	-	-	-	-	n.d.	n.d.	n.d.	n.d.	n.d.	n.d.	0.42	0.36	0.29	n.d.	n.d.	n.d.	-	-	-	-	-	
PA-5W	13310	8310	13.3	6.2	323	1260	239	284	-	-	-	-	-	-	n.d.	n.d.	n.d.	n.d.	n.d.	n.d.	2.33	1.34	0.34	1.29	0.72	0.15	-	-	-	-	-	
PAS-1E	15300	14868	13.3	12.8	375	829	480	299	-	-	-	-	-	-	n.d.	n.d.	n.d.	n.d.	n.d.	n.d.	1.08	1.08	1.08	8.32	4.51	0.69	22.7	17.4	-	-	-	
PAS-2W	-	-	-	-	-	-	-	-	-	-	-	-	-	-	-	-	-	-	-	-	-	-	-	-	-	10.8	20.5	-	-	-		
TH-1C	12274	10900	-	-	487	546	329	232	-	-	-	-	-	-	n.d.	n.d.	n.d.	n.d.	n.d.	n.d.	1.44	0.88	0.32	3.54	1.77	0.00	-	-	-	-	9.24	4.71
TH-1E	15963	8500	-	-	526	472	256	118	-	-	-	-	-	-	-	-	-	-	-	-	-	-	-	-	-	-	-	-	-	10.11	6.28	
TH-3	-	-	-	-	-	-	-	-	-	-	-	-	-	-	n.d.	n.d.	n.d.	n.d.	n.d.	n.d.	0.52	0.46	0.40	n.d.	n.d.	n.d.	-	-	-	-	14.52	n.d.
THM-1	12600	7727	32.8	12.3	-	-	-	-	-	-	-	-	-	-	-	-	-	-	-	-	-	-	-	-	-	-	-	-	-	36.31	29.28	
THS-1E	13843	6660	-	-	-	-	-	-	-	-	-	-	-	-	0.002	0.001	0.000	0.002	0.001	0.001	-	-	-	-	-	-	-	-	-	28.87	7.76	
THS-1W	-	-	-	-	-	-	-	-	-	-	-	-	-	-	-	-	-	-	-	-	-	-	-	-	-	-	-	-	60.38	6.58		
THW-1	-	-	-	-	328	440	370	220	-	-	-	-	-	-	n.d.	n.d.	n.d.	n.d.	n.d.	n.d.	-	-	-	-	-	-	-	-	-	12.81	3.90	
TW-1E	-	-	21.5	6.8	-	-	-	-	-	-	-	-	-	-	0.002	0.001	0.000	0.002	0.001	0.000	-	-	-	-	-	-	6.6	0.8	-	-	-	
TW-1W	8994	8204	14.4	5.4	555	715	236	296	-	-	-	-	-	-	0.001	0.001	0.001	0.002	0.001	0.000	1.31	0.72	0.12	1.48	0.74	0.00	-	-	-	-	-	
TW-2E	10308	11318	18.1	8.3	322	494	420	293	-	-	-	-	-	-	n.d.	n.d.	n.d.	n.d.	n.d.	n.d.	0.87	0.61	0.35	2.20	1.38	0.56	-	-	-	-	-	

Table D-1.2-1 (continued)

Reach	Iron		Lead		Manganese				Mercury			Perchlorate			Selenium			Silver		Thallium		Uranium (Total)										
	Fine Facies	Coarse Facies	Fine Facies	Coarse Facies	Pre-Fire Fine Facies	Post-Fire Fine Facies	Pre-Fire Coarse Facies	Post-Fire Coarse Facies	Fine Facies			Coarse Facies			Fine Facies			Coarse Facies			Fine Facies	Coarse Facies	Fine Facies	Coarse Facies	Fine Facies	Coarse Facies						
	Average	Average	Average	Average	Average	Average	Average	Average	Upper Bound on Mean	Mid-Point of Range	Lower Bound on Mean	Upper Bound on Mean	Mid-Point of Range	Lower Bound on Mean	Upper Bound on Mean	Mid-Point of Range	Lower Bound on Mean	Upper Bound on Mean	Mid-Point of Range	Lower Bound on Mean	Upper Bound on Mean	Mid-Point of Range	Lower Bound on Mean	Upper Bound on Mean	Mid-Point of Range	Lower Bound on Mean	Average	Average	Average	Average	Average	Average
TW-3E	-	-	-	-	-	-	-	-	-	-	-	-	-	-	0.002	0.001	0.000	0.002	0.001	0.000	1.08	0.83	0.57	1.51	0.75	0.00	-	-	-	-	-	-
TW-4E	-	-	-	-	-	-	-	-	-	-	-	-	-	-	0.003	0.002	0.001	0.002	0.001	0.000	1.04	0.80	0.55	1.50	0.75	0.00	-	-	-	-	8.27	1.43
TW-4W	-	-	14.4	6.3	272	474	573	200	-	-	-	-	-	-	-	-	-	-	-	-	0.96	0.55	0.14	1.83	0.91	0.00	-	-	-	-	-	-
TWN-1E	-	-	19.7	10.6	329	718	161	376	-	-	-	-	-	-	0.002	0.001	0.000	0.002	0.001	0.000	-	-	-	-	-	-	-	-	-	-	-	-
TWN-1W	-	-	25.5	10.7	285	421	230	215	-	-	-	-	-	-	0.002	0.001	0.000	0.002	0.001	0.000	1.35	0.82	0.29	1.47	0.74	0.00	-	-	-	-	-	-
TWSE-1E	11700	7507	-	-	511	539	196	138	-	-	-	-	-	-	0.002	0.001	0.000	0.002	0.001	0.000	1.24	0.76	0.28	1.61	0.81	0.00	-	-	-	-	-	-
TWSE-1W	13556	5970	-	-	-	-	-	-	-	-	-	-	-	-	-	-	-	-	-	-	1.21	0.79	0.36	1.48	0.74	0.00	-	-	-	-	-	-
TWSW-1E	-	-	15.9	8.9	318	1153	891	67	-	-	-	-	-	-	-	-	-	-	-	-	1.30	0.85	0.40	1.82	0.91	0.00	-	-	-	-	4.96	2.46
TWSW-1W	12030	4190	-	-	-	-	-	-	-	-	-	-	-	-	n.d.	n.d.	n.d.	n.d.	n.d.	n.d.	1.04	0.80	0.55	1.47	0.74	0.00	-	-	-	-	-	-

Table D-1.2-1 (continued)

Reach	Vanadium				Zinc			
	Fine Facies			Coarse Facies	Fine Facies			Coarse Facies
	Upper Bound on Mean	Mid-Point of Range	Lower Bound on Mean	Average	Upper Bound on Mean	Mid-Point of Range	Lower Bound on Mean	Average
BV	19.7				60.2			
AEN-1	25.1	25.1	25.1	10.8	35.7	35.7	35.7	25.3
AES-1	22.6	22.6	22.6	23.5	-	-	-	-
AW-1	40.6	40.6	40.6	25.3	75.0	73.9	72.7	36.9
PA-0	15.5	15.5	15.5	15.0	-	-	-	-
PA-1E	16.1	16.1	16.1	15.3	-	-	-	-
PA-1W	20.8	20.8	20.8	13.2	-	-	-	-
PA-2W	17.6	17.1	16.6	8.1	-	-	-	-
PA-3E	16.3	16.3	16.3	7.1	59.7	59.7	59.7	40.6
PA-4	23.4	23.4	23.4	10.2	61.6	61.6	61.6	42.4
PA-4E	-	-	-	-	-	-	-	-
PA-5W	20.5	20.5	20.5	11.1	52.3	52.3	52.3	32.9
PAS-1E	25.4	25.4	25.4	23.9	44.7	44.7	44.7	50.5
PAS-2W	20.5	20.5	20.5	18.7	-	-	-	-
TH-1C	-	-	-	-	43.8	43.8	43.8	51.2
TH-1E	24.7	24.7	24.7	9.6	-	-	-	-
TH-3	-	-	-	-	-	-	-	-
THM-1	-	-	-	-	-	-	-	-
THS-1E	-	-	-	-	-	-	-	-
THS-1W	-	-	-	-	-	-	-	-
THW-1	19.2	19.2	19.2	10.5	-	-	-	-
TW-1E	-	-	-	-	46.5	46.5	46.5	28.9
TW-1W	-	-	-	-	-	-	-	-
TW-2E	14.0	13.4	12.7	11.6	42.9	42.9	42.9	47.0
TW-3E	-	-	-	-	-	-	-	-
TW-4E	-	-	-	-	-	-	-	-
TW-4W	-	-	-	-	40.4	40.4	40.4	40.1
TWN-1E	-	-	-	-	59.6	59.6	59.6	35.5
TWN-1W	16.5	16.5	16.5	7.4	41.2	41.2	41.2	20.6
TWSE-1E	16.6	16.6	16.6	7.3	-	-	-	-
TWSE-1W	26.3	26.3	26.3	9.4	-	-	-	-
TWSW-1E	17.4	17.4	17.4	12.0	33.5	33.5	33.5	21.3
TWSW-1W	22.0	22.0	22.0	5.9	-	-	-	-

^a All units are in mg/kg.

^b dash = not a COPC in reach (not detected or no detects > BV).

^c n.d. = no data; includes post-fire columns for reaches where there are no significant fire effects.

**Table D-1.2-2
Summary of Average Concentrations of Select PCBs in the Pajarito Watershed^a**

Reach	Aroclor-1242						Aroclor-1248						Aroclor-1254						Aroclor-1260					
	Fine Facies			Coarse Facies			Fine Facies			Coarse Facies			Fine Facies			Coarse Facies			Fine Facies			Coarse Facies		
	Upper Bound on Mean	Mid-Point of Range	Lower Bound on Mean	Upper Bound on Mean	Mid-Point of Range	Lower Bound on Mean	Upper Bound on Mean	Mid-Point of Range	Lower Bound on Mean	Upper Bound on Mean	Mid-Point of Range	Lower Bound on Mean	Upper Bound on Mean	Mid-Point of Range	Lower Bound on Mean	Upper Bound on Mean	Mid-Point of Range	Lower Bound on Mean	Upper Bound on Mean	Mid-Point of Range	Lower Bound on Mean	Upper Bound on Mean	Mid-Point of Range	Lower Bound on Mean
AEN-1	^b	—	—	—	—	—	—	—	—	—	—	—	—	—	—	—	—	—	0.042	0.037	0.032	0.038	0.019	0.000
AES-1	—	—	—	—	—	—	—	—	—	—	—	—	—	—	—	—	—	—	—	—	—	—	—	—
AW-1	—	—	—	—	—	—	—	—	—	—	—	—	0.287	0.287	0.287	0.030	0.023	0.016	0.106	0.101	0.097	0.023	0.016	0.009
PA-0	—	—	—	—	—	—	—	—	—	—	—	—	—	—	—	—	—	—	—	—	—	—	—	—
PA-1E	—	—	—	—	—	—	—	—	—	—	—	—	—	—	—	—	—	—	0.023	0.012	0.000	0.003	0.002	0.001
PA-1W	—	—	—	—	—	—	—	—	—	—	—	—	0.004	0.002	0.000	0.003	0.002	0.001	0.004	0.002	0.001	0.004	0.002	0.000
PA-2W	—	—	—	—	—	—	—	—	—	—	—	—	0.025	0.012	0.000	0.019	0.010	0.001	0.025	0.013	0.001	0.020	0.010	0.000
PA-3E	—	—	—	—	—	—	—	—	—	—	—	—	0.031	0.019	0.007	0.035	0.009	0.000	0.034	0.018	0.002	0.035	0.018	0.000
PA-4	—	—	—	—	—	—	—	—	—	—	—	—	—	—	—	—	—	—	0.021	0.013	0.006	0.004	0.003	0.001
PA-4E	—	—	—	n.d. ^c	n.d.	n.d.	—	—	—	n.d.	n.d.	n.d.	—	—	—	n.d.	n.d.	n.d.	—	—	—	n.d.	n.d.	n.d.
PA-5W	0.007	0.006	0.004	0.003	0.002	0.000	0.005	0.004	0.002	0.003	0.002	0.000	0.009	0.008	0.007	0.003	0.002	0.000	0.005	0.005	0.004	0.009	0.008	0.007
PAS-1E	—	—	—	—	—	—	—	—	—	—	—	—	0.004	0.002	0.001	0.027	0.013	0.000	0.003	0.002	0.000	0.027	0.013	0.000
PAS-2W	—	—	—	—	—	—	—	—	—	—	—	—	0.026	0.013	0.000	0.004	0.004	0.004	—	—	—	—	—	—
TH-1C	n.d.	n.d.	n.d.	n.d.	n.d.	n.d.	n.d.	n.d.	n.d.	n.d.	n.d.	n.d.	n.d.	n.d.	n.d.	n.d.	n.d.	n.d.	n.d.	n.d.	n.d.	n.d.	n.d.	n.d.
TH-1E	—	—	—	—	—	—	—	—	—	—	—	—	—	—	—	—	—	—	—	—	—	—	—	—
TH-3	—	—	—	n.d.	n.d.	n.d.	—	—	—	n.d.	n.d.	n.d.	—	—	—	n.d.	n.d.	n.d.	—	—	—	n.d.	n.d.	n.d.
THM-1	—	—	—	—	—	—	—	—	—	—	—	—	0.012	0.011	0.010	0.005	0.005	0.005	0.007	0.005	0.004	0.002	0.002	0.001
THS-1E	—	—	—	—	—	—	—	—	—	—	—	—	—	—	—	—	—	—	—	—	—	—	—	—
THS-1W	n.d.	n.d.	n.d.	n.d.	n.d.	n.d.	n.d.	n.d.	n.d.	n.d.	n.d.	n.d.	n.d.	n.d.	n.d.	n.d.	n.d.	n.d.	n.d.	n.d.	n.d.	n.d.	n.d.	n.d.
THW-1	n.d.	n.d.	n.d.	n.d.	n.d.	n.d.	n.d.	n.d.	n.d.	n.d.	n.d.	n.d.	n.d.	n.d.	n.d.	n.d.	n.d.	n.d.	n.d.	n.d.	n.d.	n.d.	n.d.	n.d.
TW-1E	—	—	—	—	—	—	0.151	0.141	0.130	0.034	0.017	0.000	—	—	—	—	—	—	0.034	0.021	0.007	0.034	0.017	0.000
TW-1W	—	—	—	—	—	—	—	—	—	—	—	—	—	—	—	—	—	—	0.015	0.008	0.000	0.015	0.008	0.000
TW-2E	—	—	—	—	—	—	0.046	0.033	0.019	0.072	0.067	0.061	0.074	0.070	0.066	0.017	0.013	0.008	0.062	0.056	0.049	0.017	0.011	0.005
TW-3E	—	—	—	—	—	—	—	—	—	—	—	—	0.017	0.016	0.016	0.013	0.008	0.002	0.016	0.016	0.016	0.013	0.007	0.001
TW-4E	—	—	—	—	—	—	—	—	—	—	—	—	0.028	0.028	0.028	0.004	0.004	0.004	0.017	0.017	0.017	0.002	0.002	0.002
TW-4W	—	—	—	—	—	—	—	—	—	—	—	—	0.035	0.028	0.020	0.027	0.016	0.005	0.037	0.023	0.007	0.041	0.020	0.000
TWN-1E	—	—	—	—	—	—	0.035	0.032	0.029	0.036	0.025	0.015	0.081	0.078	0.075	0.051	0.044	0.037	0.062	0.062	0.062	0.046	0.039	0.032
TWN-1W	—	—	—	—	—	—	—	—	—	—	—	—	—	—	—	—	—	—	—	—	—	—	—	—
TWSE-1E	—	—	—	—	—	—	—	—	—	—	—	—	0.020	0.011	0.002	0.003	0.002	0.001	0.024	0.012	0.001	0.003	0.003	0.002
TWSE-1W	—	—	—	—	—	—	—	—	—	—	—	—	—	—	—	—	—	—	0.011	0.011	0.011	0.003	0.003	0.003
TWSW-1E	—	—	—	—	—	—	—	—	—	—	—	—	0.029	0.015	0.000	0.004	0.002	0.000	—	—	—	—	—	—
TWSW-1W	0.004	0.002	0.000	0.003	0.002	0.000	—	—	—	—	—	—	0.003	0.002	0.000	0.003	0.002	0.000	0.003	0.002	0.000	0.003	0.002	0.000

^a All units are in mg/kg.

^b Dash = Not a COPC in reach (not detected).

^c n.d. = No data.

Table D-1.2-3
Summary of Average Concentrations of Select PAHs in the Pajarito Watershed^a

Reach	Anthracene						Benzo(a)anthracene						Benzo(a)pyrene						Benzo(b)fluoranthene						Napthalene											
	Fine Facies			Coarse Facies			Fine Facies			Coarse Facies			Fine Facies			Coarse Facies			Fine Facies			Coarse Facies			Fine Facies			Coarse Facies								
	Upper Bound on Mean	Mid-Point of Range	Lower Bound on Mean	Upper Bound on Mean	Mid-Point of Range	Lower Bound on Mean	Upper Bound on Mean	Mid-Point of Range	Lower Bound on Mean	Upper Bound on Mean	Mid-Point of Range	Lower Bound on Mean	Upper Bound on Mean	Mid-Point of Range	Lower Bound on Mean	Upper Bound on Mean	Mid-Point of Range	Lower Bound on Mean	Upper Bound on Mean	Mid-Point of Range	Lower Bound on Mean	Upper Bound on Mean	Mid-Point of Range	Lower Bound on Mean	Upper Bound on Mean	Mid-Point of Range	Lower Bound on Mean	Upper Bound on Mean	Mid-Point of Range	Lower Bound on Mean						
AEN-1	0.188	0.094	0.001	0.019	0.009	0.000	0.198	0.106	0.014	0.011	0.011	0.010	0.114	0.100	0.086	0.007	0.004	0.000	^b	—	—	—	—	—	—	—	—	—	—	—	—	—	—	—	—	—
AES-1	—	—	—	—	—	—	0.021	0.011	0.002	0.002	0.001	0.000	—	—	—	—	—	—	—	—	—	—	—	—	—	—	—	—	—	—	—	—	—	—	—	—
AW-1	0.056	0.047	0.039	0.033	0.017	0.000	0.149	0.145	0.141	0.023	0.016	0.009	0.168	0.166	0.164	0.025	0.013	0.000	0.266	0.229	0.192	0.041	0.020	0.000	0.065	0.037	0.009	0.035	0.017	0.000						
PA-0	—	—	—	—	—	—	—	—	—	—	—	—	—	—	—	—	—	—	—	—	—	—	—	—	—	—	—	—	—	—	—	—	—	—	—	—
PA-1E	—	—	—	—	—	—	—	—	—	—	—	—	—	—	—	—	—	—	—	—	—	—	—	—	—	—	—	—	—	—	—	—	—	—	—	—
PA-1W	—	—	—	—	—	—	0.024	0.013	0.003	0.002	0.001	0.000	—	—	—	—	—	—	—	—	—	—	—	—	—	—	—	—	—	—	—	—	—	—	—	—
PA-2W	—	—	—	—	—	—	0.014	0.008	0.002	0.004	0.002	0.000	—	—	—	—	—	—	—	—	—	—	—	—	—	—	—	—	—	—	—	—	—	—	—	—
PA-3E	0.078	0.043	0.008	0.104	0.052	0.000	0.041	0.036	0.030	0.013	0.006	0.000	0.035	0.031	0.027	0.012	0.006	0.000	0.041	0.028	0.014	0.011	0.006	0.000	—	—	—	—	—	—	—	—	—	—	—	—
PA-4	0.029	0.023	0.018	0.017	0.009	0.000	0.069	0.057	0.044	0.002	0.001	0.000	0.044	0.040	0.036	0.002	0.001	0.000	0.066	0.060	0.055	0.003	0.001	0.000	—	—	—	—	—	—	—	—	—	—	—	—
PA-4E	—	—	—	—	—	—	—	—	—	—	—	—	—	—	—	—	—	—	—	—	—	—	—	—	—	—	—	—	—	—	—	—	—	—	—	—
PA-5W	0.081	0.040	0.000	0.017	0.009	0.000	0.027	0.023	0.020	0.002	0.001	0.000	0.018	0.016	0.015	0.002	0.001	0.000	—	—	—	—	—	—	—	—	—	—	—	—	—	—	—	—	—	—
PAS-1E	0.081	0.040	0.000	0.015	0.008	0.002	0.037	0.034	0.032	0.007	0.006	0.005	0.047	0.030	0.014	0.008	0.007	0.005	—	—	—	—	—	—	—	—	—	—	—	—	—	—	—	—	—	—
PAS-2W	0.046	0.039	0.031	0.017	0.008	0.000	0.090	0.088	0.086	0.006	0.003	0.000	0.083	0.080	0.078	0.008	0.004	0.000	—	—	—	—	—	—	0.049	0.040	0.032	0.017	0.008	0.000						
TH-1C	—	—	—	—	—	—	—	—	—	—	—	—	—	—	—	—	—	—	—	—	—	—	—	—	—	—	—	—	—	—	—	—	—	—	—	—
TH-1E	—	—	—	—	—	—	0.018	0.009	0.001	0.002	0.001	0.000	—	—	—	—	—	—	—	—	—	—	—	—	—	—	—	—	—	—	—	—	—	—	—	—
TH-3	—	—	—	—	—	—	—	—	—	—	—	—	—	—	—	—	—	—	—	—	—	—	—	—	—	—	—	—	—	—	—	—	—	—	—	—
THM-1	—	—	—	—	—	—	—	—	—	—	—	—	—	—	—	—	—	—	—	—	—	—	—	—	—	—	—	—	—	—	—	—	—	—	—	—
THS-1E	—	—	—	—	—	—	—	—	—	—	—	—	—	—	—	—	—	—	—	—	—	—	—	—	—	—	—	—	—	—	—	—	—	—	—	—
THS-1W	—	—	—	—	—	—	—	—	—	—	—	—	—	—	—	—	—	—	—	—	—	—	—	—	—	—	—	—	—	—	—	—	—	—	—	—
THW-1	—	—	—	—	—	—	—	—	—	—	—	—	—	—	—	—	—	—	—	—	—	—	—	—	—	—	—	—	—	—	—	—	—	—	—	—
TW-1E	—	—	—	—	—	—	—	—	—	—	—	—	0.026	0.023	0.020	0.010	0.005	0.000	0.015	0.013	0.011	0.012	0.006	0.000	—	—	—	—	—	—	—	—	—	—	—	—
TW-1W	—	—	—	—	—	—	—	—	—	—	—	—	—	—	—	—	—	—	—	—	—	—	—	—	—	—	—	—	—	—	—	—	—	—	—	—
TW-2E	0.041	0.041	0.041	0.060	0.030	0.000	0.136	0.136	0.136	0.008	0.005	0.003	0.113	0.113	0.113	0.008	0.004	0.000	0.166	0.144	0.122	0.011	0.005	0.000	—	—	—	—	—	—	—	—	—	—	—	—
TW-3E	0.028	0.020	0.012	0.017	0.009	0.000	0.060	0.059	0.057	0.002	0.001	0.000	0.055	0.053	0.052	0.002	0.001	0.000	—	—	—	—	—	—	—	—	—	—	—	—	—	—	—	—	—	—
TW-4E	0.046	0.027	0.008	0.017	0.008	0.000	0.106	0.073	0.040	0.002	0.001	0.000	0.080	0.071	0.062	0.001	0.000	0.000	0.140	0.124	0.108	0.002	0.001	0.000	—	—	—	—	—	—	—	—	—	—	—	—
TW-4W	0.040	0.022	0.005	0.033	0.027	0.022	0.042	0.041	0.040	0.083	0.083	0.083	0.034	0.027	0.021	0.061	0.056	0.052	0.046	0.023	0.000	0.099	0.091	0.083	—	—	—	—	—	—	—	—	—	—	—	—
TWN-1E	0.126	0.121	0.116	6.18	6.17	6.17	0.408	0.390	0.372	7.99	7.99	7.99	0.366	0.358	0.350	5.40	5.40	5.40	0.389	0.361	0.334	6.21	3.15	0.09	0.074	0.037	0.000	8.57	8.55	8.54						
TWN-1E ^c	0.126	0.121	0.116	0.042	0.039	0.035	0.408	0.390	0.372	0.133	0.132	0.131	0.366	0.358	0.350	0.123	0.123	0.123	0.389	0.361	0.334	0.126	0.124	0.122	0.074	0.037	0.000	0.029	0.015	0.000						
TWN-1W	—	—	—	—	—	—	—	—	—	—	—	—	—	—	—	—	—	—	—	—	—	—	—	—	—	—	—	—	—	—	—	—	—	—	—	—
TWSE-1E	0.019	0.010	0.001	0.018	0.009	0.000	0.029	0.016	0.004	0.002	0.001	0.000	0.013	0.008	0.003	0.002	0.001	0.000	—	—	—	—	—	—	—	—	—	—	—	—	—	—	—	—	—	—
TWSE-1W	—	—	—	—	—	—	—	—	—	—	—	—	—	—	—	—	—	—	—	—	—	—	—	—	—	—	—	—	—	—	—	—	—	—	—	—
TWSW-1E	—	—	—	—	—	—	—	—	—	—	—	—	—	—	—	—	—	—	—	—	—	—	—	—	—	—	—	—	—	—	—	—	—	—	—	—
TWSW-1W	0.016	0.008	0.001	0.017	0.008	0.000	—	—	—	—	—	—	—	—	—	—	—	—	—	—	—	—	—	—	—	—	—	—	—	—	—	—	—	—	—	—

^a All units are in mg/kg.

^b — = Not a COPC in reach (not detected).

^c 2nd row for TWN-1E uses resample values for sampled layer with anomalously high PAH results.

**Table D-1.2-4
Summary of Average Concentrations of Select SVOCs in the Pajarito Watershed^a**

Reach	Benzoic Acid						Bis[2-ethylhexyl]phthalate						Di-n-butylphthalate					
	Fine Facies			Coarse Facies			Fine Facies			Coarse Facies			Fine Facies			Coarse Facies		
	Upper Bound on Mean	Mid-Point of Range	Lower Bound on Mean	Upper Bound on Mean	Mid-Point of Range	Lower Bound on Mean	Upper Bound on Mean	Mid-Point of Range	Lower Bound on Mean	Upper Bound on Mean	Mid-Point of Range	Lower Bound on Mean	Upper Bound on Mean	Mid-Point of Range	Lower Bound on Mean	Upper Bound on Mean	Mid-Point of Range	Lower Bound on Mean
AEN-1	— ^b	—	—	—	—	—	—	—	—	—	—	—	—	—	—	—	—	—
AES-1	—	—	—	—	—	—	—	—	—	—	—	—	—	—	—	—	—	—
AW-1	1.294	0.647	0.000	1.053	0.594	0.134	0.327	0.189	0.052	0.266	0.146	0.027	0.638	0.375	0.113	0.548	0.274	0.000
PA-0	1.085	0.824	0.562	0.700	0.350	0.000	—	—	—	—	—	—	—	—	—	—	—	—
PA-1E	—	—	—	—	—	—	—	—	—	—	—	—	—	—	—	—	—	—
PA-1W	—	—	—	—	—	—	—	—	—	—	—	—	—	—	—	—	—	—
PA-2W	—	—	—	—	—	—	—	—	—	—	—	—	—	—	—	—	—	—
PA-3E	—	—	—	—	—	—	—	—	—	—	—	—	—	—	—	—	—	—
PA-4	—	—	—	—	—	—	0.358	0.181	0.004	0.280	0.140	0.000	0.337	0.176	0.015	0.336	0.168	0.000
PA-4E	1.762	0.942	0.122	n.d. ^c	n.d.	n.d.	—	—	—	—	—	—	—	—	—	—	—	—
PA-5W	—	—	—	—	—	—	—	—	—	—	—	—	—	—	—	—	—	—
PAS-1E	—	—	—	—	—	—	—	—	—	—	—	—	—	—	—	—	—	—
PAS-2W	0.648	0.395	0.142	0.678	0.339	0.000	—	—	—	—	—	—	—	—	—	—	—	—
TH-1C	—	—	—	—	—	—	—	—	—	—	—	—	—	—	—	—	—	—
TH-1E	0.742	0.400	0.059	0.760	0.380	0.000	—	—	—	—	—	—	—	—	—	—	—	—
TH-3	—	—	—	—	—	—	—	—	—	—	—	—	—	—	—	—	—	—
THM-1	0.629	0.419	0.209	0.685	0.343	0.000	0.447	0.320	0.193	0.216	0.160	0.103	—	—	—	—	—	—

Table D-1.2-4 (continued)

Reach	Benzoic Acid						Bis[2-ethylhexyl]phthalate						Di-n-butylphthalate					
	Fine Facies			Coarse Facies			Fine Facies			Coarse Facies			Fine Facies			Coarse Facies		
	Upper Bound on Mean	Mid-Point of Range	Lower Bound on Mean	Upper Bound on Mean	Mid-Point of Range	Lower Bound on Mean	Upper Bound on Mean	Mid-Point of Range	Lower Bound on Mean	Upper Bound on Mean	Mid-Point of Range	Lower Bound on Mean	Upper Bound on Mean	Mid-Point of Range	Lower Bound on Mean	Upper Bound on Mean	Mid-Point of Range	Lower Bound on Mean
THS-1E	0.715	0.439	0.163	0.690	0.345	0.000	—	—	—	—	—	—	—	—	—	—	—	—
THS-1W	—	—	—	—	—	—	—	—	—	—	—	—	—	—	—	—	—	—
THW-1	—	—	—	—	—	—	—	—	—	—	—	—	—	—	—	—	—	—
TW-1E	0.666	0.390	0.114	1.873	0.937	0.000	—	—	—	—	—	—	—	—	—	—	—	—
TW-1W	—	—	—	—	—	—	—	—	—	—	—	—	—	—	—	—	—	—
TW-2E	—	—	—	—	—	—	—	—	—	—	—	—	—	—	—	—	—	—
TW-3E	—	—	—	—	—	—	—	—	—	—	—	—	—	—	—	—	—	—
TW-4E	—	—	—	—	—	—	—	—	—	—	—	—	—	—	—	—	—	—
TW-4W	—	—	—	—	—	—	—	—	—	—	—	—	—	—	—	—	—	—
TWN-1E	1.333	0.722	0.111	0.727	0.363	0.000	—	—	—	—	—	—	0.618	0.313	0.007	0.363	0.182	0.000
TWN-1W	—	—	—	—	—	—	0.471	0.247	0.022	0.167	0.084	0.000	—	—	—	—	—	—
TWSE-1E	4.032	2.062	0.091	0.720	0.360	0.000	0.980	0.530	0.079	0.264	0.144	0.024	—	—	—	—	—	—
TWSE-1W	—	—	—	—	—	—	—	—	—	—	—	—	—	—	—	—	—	—
TWSW-1E	—	—	—	—	—	—	—	—	—	—	—	—	—	—	—	—	—	—
TWSW-1W	n.d.	n.d.	n.d.	n.d.	n.d.	n.d.	n.d.	n.d.	n.d.	n.d.	n.d.	n.d.	n.d.	n.d.	n.d.	n.d.	n.d.	n.d.

^a All units are in mg/kg.

^b — = Not a COPC in reach (not detected).

^c n.d. = No data.

Table D-1.2-5
Summary of Average Concentrations of TATB in the Pajarito Watershed^a

Reach	TATB					
	Fine Facies			Coarse Facies		
	Upper Bound on Mean	Mid-Point of Range	Lower Bound on Mean	Upper Bound on Mean	Mid-Point of Range	Lower Bound on Mean
AEN-1	1.81	1.56	1.31	1.14	0.89	0.64
AES-1	— ^b	—	—	—	—	—
AW-1	—	—	—	—	—	—
PA-0	—	—	—	—	—	—
PA-1E	0.87	0.54	0.21	1.00	0.50	0.00
PA-1W	—	—	—	—	—	—
PA-2W	0.96	0.50	0.05	1.00	0.50	0.00
PA-3E	0.93	0.48	0.03	1.00	0.50	0.00
PA-4	—	—	—	—	—	—
PA-4E	—	—	—	n.d. ^c	n.d.	n.d.
PA-5W	—	—	—	—	—	—
PAS-1E	—	—	—	—	—	—
PAS-2W	—	—	—	—	—	—
TH-1C	—	—	—	—	—	—
TH-1E	—	—	—	—	—	—
TH-3	—	—	—	n.d.	n.d.	n.d.
THM-1	—	—	—	—	—	—
THS-1E	—	—	—	—	—	—
THS-1W	—	—	—	—	—	—
THW-1	—	—	—	—	—	—
TW-1E	—	—	—	—	—	—
TW-1W	n.d.	n.d.	n.d.	n.d.	n.d.	n.d.
TW-2E	—	—	—	—	—	—
TW-3E	—	—	—	—	—	—
TW-4E	—	—	—	—	—	—
TW-4W	—	—	—	—	—	—
TWN-1E	—	—	—	—	—	—
TWN-1W	—	—	—	—	—	—
TWSE-1E	—	—	—	—	—	—
TWSE-1W	—	—	—	—	—	—
TWSW-1E	—	—	—	—	—	—
TWSW-1W	—	—	—	—	—	—

^a All units are in mg/kg.

^b — = Not a COPC in reach (not detected).

^c n.d. = No data.

**Table D-1.2-6
Summary of Average Concentrations of Select Dioxins and Furans in the Pajarito Watershed^a**

Reach	Pentachlorodibenzodioxins (Total)						Pentachlorodibenzofurans (Total)						Tetrachlorodibenzodioxins (Total)						Tetrachlorodibenzofurans (Total)					
	Fine Facies			Coarse Facies			Fine Facies			Coarse Facies			Fine Facies			Coarse Facies			Fine Facies			Coarse Facies		
	Upper Bound on Mean	Mid-Point of Range	Lower Bound on Mean	Upper Bound on Mean	Mid-Point of Range	Lower Bound on Mean	Upper Bound on Mean	Mid-Point of Range	Lower Bound on Mean	Upper Bound on Mean	Mid-Point of Range	Lower Bound on Mean	Upper Bound on Mean	Mid-Point of Range	Lower Bound on Mean	Upper Bound on Mean	Mid-Point of Range	Lower Bound on Mean	Upper Bound on Mean	Mid-Point of Range	Lower Bound on Mean	Upper Bound on Mean	Mid-Point of Range	Lower Bound on Mean
PA-3E	1.17	1.17	1.17	n.d. ^b	n.d.	n.d.	3.82	3.82	3.82	n.d.	n.d.	n.d.	0.60	0.60	0.60	n.d.	n.d.	n.d.	3.66	3.66	3.66	n.d.	n.d.	n.d.
TW-1E	2.69	2.56	2.44	0.42	0.33	0.24	6.16	6.14	6.12	1.36	1.31	1.27	1.46	1.37	1.28	0.25	0.13	0.00	33.36	33.34	33.33	9.32	9.26	9.21
TW-1W	0.20	0.13	0.07	0.16	0.08	0.00	0.57	0.54	0.50	0.24	0.23	0.22	0.83	0.80	0.77	0.12	0.06	0.00	0.37	0.33	0.29	0.13	0.06	0.00
TW-2E	1.00	0.99	0.98	0.13	0.07	0.00	8.69	8.69	8.69	0.89	0.89	0.89	0.93	0.91	0.89	0.09	0.04	0.00	23.37	23.37	23.37	0.93	0.91	0.90
TW-4E	1.14	1.14	1.14	n.d.	n.d.	n.d.	7.16	7.16	7.16	n.d.	n.d.	n.d.	1.01	1.01	1.01	n.d.	n.d.	n.d.	5.04	5.04	5.04	n.d.	n.d.	n.d.

^a All units are in mg/kg.

^b n.d. = No data.

Table D-1.2-7
Summary of Average Concentrations of DDT in the Pajarito Watershed^a

Reach	DDT					
	Fine Facies			Coarse Facies		
	Upper Bound on Mean	Mid-Point of Range	Lower Bound on Mean	Upper Bound on Mean	Mid-Point of Range	Lower Bound on Mean
AEN-1	— ^b	—	—	—	—	—
AES-1	0.012	0.006	0.001	0.014	0.007	0.000
AW-1	—	—	—	—	—	—
PA-0	0.004	0.003	0.002	0.001	0.001	0.000
PA-1E	0.005	0.003	0.000	0.006	0.003	0.000
PA-1W	—	—	—	—	—	—
PA-2W	—	—	—	—	—	—
PA-3E	—	—	—	—	—	—
PA-4	—	—	—	—	—	—
PA-4E	0.004	0.003	0.002	n.d. ^c	n.d.	n.d.
PA-5W	0.002	0.001	0.000	0.003	0.001	0.000
PAS-1E	0.012	0.007	0.002	0.014	0.007	0.000
PAS-2W	0.012	0.008	0.003	0.012	0.009	0.006
TH-1C	n.d.	n.d.	n.d.	n.d.	n.d.	n.d.
TH-1E	—	—	—	—	—	—
TH-3	—	—	—	—	—	—
THM-1	—	—	—	—	—	—
THS-1E	—	—	—	—	—	—
THS-1W	n.d.	n.d.	n.d.	n.d.	n.d.	n.d.
THW-1	-	-	-	-	-	-
TW-1E	0.014	0.010	0.006	0.015	0.007	0.000
TW-1W	0.007	0.004	0.001	0.011	0.005	0.000
TW-2E	—	—	—	—	—	—
TW-3E	—	—	—	—	—	—
TW-4E	—	—	—	—	—	—
TW-4W	—	—	—	—	—	—
TWN-1E	—	—	—	—	—	—
TWN-1W	n.d.	n.d.	n.d.	n.d.	n.d.	n.d.
TWSE-1E	—	—	—	—	—	—
TWSE-1W	—	—	—	—	—	—
TWSW-1E	—	—	—	—	—	—
TWSW-1W	n.d.	n.d.	n.d.	n.d.	n.d.	n.d.

^a All units are in mg/kg.

^b — = Not a COPC in reach (not detected).

^c n.d. = No data.

Table D-1.2-8
Summary of Average Concentrations of Select Radionuclides in the Pajarito Watershed^a

Reach	Cesium-137				Plutonium-239,240				Thorium-228		Thorium-232		Uranium-238	
	Pre-Fire Fine Facies	Post-Fire Fine Facies	Pre-Fire Coarse Facies	Post-Fire Coarse Facies	Pre-Fire Fine Facies	Post-Fire Fine Facies	Pre-Fire Coarse Facies	Post-Fire Coarse Facies	Fine Facies	Coarse Facies	Fine Facies	Coarse Facies	Fine Facies	Coarse Facies
BV	0.90				0.068				2.28		2.33		2.29	
AEN-1	0.39	n.d. ^b	0.06	0.04	— ^c	—	—	—	—	—	—	—	1.74	1.19
AES-1	—	—	—	—	—	—	—	—	—	—	—	—	—	—
AW-1	0.37	-	0.08	-	n.d.	n.d.	n.d.	n.d.	n.d.	n.d.	n.d.	n.d.	1.45	0.88
PA-0	0.58	1.82	n.d.	0.44	0.039	0.814	n.d.	0.026	n.d.	n.d.	n.d.	n.d.	—	—
PA-1E	—	—	—	—	—	—	—	—	n.d.	n.d.	n.d.	n.d.	—	—
PA-1W	—	—	—	—	—	—	—	—	n.d.	n.d.	n.d.	n.d.	—	—
PA-2W	0.45	1.03	0.07	0.09	0.018	0.038	0.012	0.011	—	—	—	—	1.67	1.08
PA-3E	0.24	2.14	0.04	0.02	0.011	0.124	0.007	-0.003	—	—	—	—	1.32	0.57
PA-4	0.38	3.78	0.07	n.d.	0.037	0.181	0.017	n.d.	1.57	1.67	—	—	—	—
PA-4E	0.59	1.81	n.d.	n.d.	—	—	—	—	n.d.	n.d.	n.d.	n.d.	—	—
PA-5W	0.22	1.62	0.23	0.07	-0.001	0.086	-0.004	0.015	—	—	—	—	—	—
PAS-1E	0.22	2.28	0.11	0.01	n.d.	n.d.	n.d.	n.d.	n.d.	n.d.	n.d.	n.d.	—	—
PAS-2W	—	—	—	—	—	—	—	—	—	—	—	—	—	—
TH-1C	0.44	0.97	-0.04	0.23	n.d.	n.d.	n.d.	n.d.	n.d.	n.d.	n.d.	n.d.	3.10	1.58
TH-1E	0.33	1.00	0.17	n.d.	—	—	—	—	—	—	—	—	3.40	2.11
TH-3	0.52	n.d.	n.d.	n.d.	—	—	—	—	n.d.	n.d.	n.d.	n.d.	4.88	n.d.
THM-1	0.30	1.08	0.07	0.12	—	—	—	—	—	—	—	—	12.20	9.84
THS-1E	—	—	—	—	—	—	—	—	1.61	1.86	1.43	1.57	8.81	2.61
THS-1W	n.d.	n.d.	n.d.	n.d.	n.d.	n.d.	n.d.	n.d.	—	—	—	—	20.29	2.21
THW-1	0.50	0.97	0.10	0.11	n.d.	n.d.	n.d.	n.d.	n.d.	n.d.	n.d.	n.d.	4.30	1.31
TW-1E	—	—	—	—	—	—	—	—	—	—	—	—	—	—
TW-1W	n.d.	n.d.	n.d.	n.d.	n.d.	n.d.	n.d.	n.d.	n.d.	n.d.	n.d.	n.d.	n.d.	n.d.
TW-2E	0.33	n.d.	n.d.	n.d.	—	—	—	—	n.d.	n.d.	n.d.	n.d.	—	—
TW-3E	0.12	0.68	n.d.	0.27	—	—	—	—	n.d.	n.d.	n.d.	n.d.	—	—
TW-4E	n.d.	0.74	n.d.	0.05	n.d.	0.020	n.d.	-0.003	n.d.	n.d.	n.d.	n.d.	2.78	0.48
TW-4W	—	—	—	—	0.016	0.031	0.022	-0.011	—	—	—	—	—	—
TWN-1E	0.26	1.36	0.04	0.04	0.021	0.062	0.000	0.005	—	—	—	—	—	—
TWN-1W	0.30	0.75	0.03	0.05	—	—	—	—	n.d.	n.d.	n.d.	n.d.	n.d.	n.d.
TWSE-1E	0.32	1.07	0.41	0.15	0.027	0.003	0.005	0.023	—	—	—	—	—	—
TWSE-1W	—	—	—	—	—	—	—	—	—	—	—	—	—	—
TWSW-1E	0.31	2.60	0.23	0.17	0.041	0.583	0.038	0.012	—	—	—	—	1.67	0.83
TWSW-1W	—	—	—	—	—	—	—	—	n.d.	n.d.	n.d.	n.d.	—	—

^a All units are in pCi/g.

^b n.d. = No data; includes cells for post-fire sediment in reaches where there are no significant fire effects.

^c — = Not a COPC in reach; not detected or all detects below BVs.

Appendix E

Statistics and Risk Information

E-1.0 INFORMATION SUPPORTING THE BASELINE ECOLOGICAL RISK ASSESSMENT

This appendix provides plots of various ecological measures to evaluate trends with chemicals of potential ecological concern (COPECs) or associations with other relevant factors at Los Alamos National Laboratory (the Laboratory). Tables of information to support the ecological exposure evaluation are also provided.

E-1.1 Information Supporting the Ecological Exposure Evaluation

The toxicity reference values (TRVs) used in the wildlife exposure evaluation are listed in Table E-1.1-1 for all COPECs. All TRVs are from the Ecorisk Database Version 2.2 (LANL 2005, 090032). The exposure parameters are summarized in Table E-1.1-2 for all wildlife receptors evaluated.

E-1.2 Plots Supporting Lines of Evidence for Birds

Nest box measurements were collected in the Pajarito watershed, other locations on the Laboratory, and at reference site locations. Reference site locations were selected based on distance from Laboratory contaminant sources and include nest boxes in Cañada del Buey, Guaje Canyon, and the Los Alamos Municipal Golf course. Measurements collected included clutch size, number of eggs hatched, percent eggs hatched, number of fledged young, percent fledged young, and percent females observed.

Table E-1.2-1 summarizes the number of nest box monitoring locations by year for reaches in the Pajarito watershed, reference locations, and other canyons. Table E-1.2-2 summarizes the number of active nests by year for reaches in Pajarito watershed, reference locations, and other canyons. Note that for some nest monitoring stations and active nest locations, no reach was indicated because these locations were sited on mesas that are distant from the canyon bottoms. These locations are located in the Pajarito watershed but are denoted as “no reach” in the results. Table E-1.2-3 provides a crosswalk of location names used for the avian nest box monitoring network with reach and watershed designations used elsewhere in the report.

Section E-1.2.1 compares bird measures among species and Section E-1.2.2 evaluates temporal trends in bird measures for western bluebirds. Section E-1.2.3 presents an evaluation of differences in bird measures for various data groups.

E-1.2.1 Box Plots Comparing Bird Nest Success and Egg Measures by Species

Figures E-1.2-1 and E-1.2-2 provide a comparison of the measures (percent of nestlings fledged and percent of nestlings that are female) across species using box plots. Boxes in these figures indicate the interquartile range of the sample results, with the upper and lower ends defined by the 75th and 25th percentiles, respectively. Horizontal lines within the boxes indicate median values; horizontal lines above and below the boxes represent the 5th and 95th percentiles of the data. These plots demonstrate that there are not significant differences for these measures between species.

As with the measures of the nestlings, egg length may vary between species. Figure E-1.2-3 compares egg length across species, Figure E-1.2-4 compares egg weight across species, and Figure E-1.2-5 compares eggshell thickness across species. As expected, there are differences between these measures for some species. Ash-throated flycatchers, western bluebirds, and mountain bluebirds have very similar ranges of values for these measures. Egg weight and length for the violet-green swallow overlap with the western bluebird as well, although the values cluster at the lower end of the range. Egg

lengths for the house finch and the mountain chickadee are smaller than the other species, although the egg weights are closer to those of the other species.

E-1.2.2 Plots of Bird Nest Success and Egg Measures by Year

Measures of nestlings can also potentially be affected by factors, such as climate and food supply that vary across years. Figures E-1.2-6 and E-1.2-7 show the time trends for fledging success and the percentage of females for western bluebirds. No biologically relevant trends over time are discernible for either measure, indicating that potential confounding factors did not exert an effect across the time period for the dataset.

Measures of egg size can also potentially be affected by factors such as climate and food supply that vary across years. Figure E-1.2-8 compares egg length for all species across years. Figure E-1.2-9 compares egg weight versus time for all species. The same comparison for eggshell thickness is shown in Figure E-1.2-10. None of the three egg measures display a biologically meaningful trend over time, indicating that the potential confounding factors did not exert an effect across the time period for the dataset.

E-1.2.3 Comparison of Bird Nest Success among Various Data Groups

Nest box measurements were analyzed for differences in nest success among canyon, data location groups, canyon segments, and reaches. The comparisons are based on results for all species, and the data are presented in box plots. Boxes in these figures indicate the interquartile range of the sample results, with the upper and lower ends defined by the 75th and 25th percentiles, respectively. Horizontal lines within the boxes indicate median values, and horizontal lines above and below the boxes represent the 5th and 95th percentiles of the data. Dunnett's *t*-test results are presented in the right-hand section of each figure. The comparison circles indicate statistical differences between the tests and the reference sites. The reference site sample for the Dunnett's *t*-test is displayed as a heavy red circle, and the text for the reference site is printed in bold red text on the x-axis. Thin red circles represent samples that are not statistically different ($p < 0.05$), and the watershed names are displayed in red on the axis. Heavy grey circles represent samples that are statistically different; these names are printed in black on the x-axis.

Canyon. Nest box measurements were compared from locations identified as Twomile, Threemile, and Pajarito Canyons. These locations are not necessarily in the canyon bottoms; for example, the nest boxes in Threemile Canyon are located on the mesas adjacent to the canyon bottom. Reference site measurements (representing Cañada del Buey, Guaje Canyon and Golf Course locations) were plotted for comparison. Nest box measures were plotted for various canyons in Figures E-1.2-11 to E-1.2-16. Significant differences between Pajarito watershed nest box measurements and reference nest box measurements included the number of eggs hatched, the number of birds fledged, and the percent fledged. The number of eggs hatched in Twomile, Threemile and Pajarito Canyons did not differ significantly from reference locations. The number of birds fledged and the percent fledged for Twomile Canyon were significantly higher than reference locations. The number of birds fledged in Pajarito Canyon was also significantly higher than reference locations. No differences in the number or percent fledged were observed between Threemile Canyon and reference or other canyon results. No differences were observed between Twomile, Threemile, and Pajarito Canyons, other locations, and reference measurements in terms of clutch size, percent eggs hatched, or percent females observed. In summary, none of the canyon nest box measures showed statistical decreases relative to reference site levels; therefore, there is no evidence of impairment of nesting success at Laboratory locations relative to reference locations.

Location Group. Nest box measurements were compared among Pajarito watershed nest box location group names. For comparison purposes, nest box measurements from reference locations and other canyons are presented. Nest box measures were plotted for various location groups in Figures E-1.2-17 to E-1.2-22. Nest box measurements were compared between named nest box locations (groups) in the Pajarito watershed. Where there were less than two observations for a given locations group, the location group was excluded from analysis. Significant differences between location group and reference locations were observed for the number and percent of birds fledged. The number of birds fledged at Technical Area 22 (TA-22) and TA-08 was significantly higher than reference locations. The percent of birds fledged at TA-22 were significantly higher than reference locations. No other location groups differed significantly from reference in terms of the number or percent of birds fledged. No differences were observed between group locations (DX, Pajarito, PJDAM, TA-22, TA-51, and TA-08), other locations, and reference location measurements in terms of clutch size, percent eggs hatched, number of eggs hatched, or percent females observed. In summary, none of the location groups nest box measures showed statistical decreases relative to reference site levels; therefore, there is no evidence of impairment of nesting success at Pajarito watershed locations relative to reference locations.

Canyon Segment. Nest box data were grouped by geographic regions/canyons in the Pajarito watershed. Canyons segments, as used here, included Upper Pajarito, Twomile, Threemile, and lower Pajarito Canyons. Reference site data were included in the plots for comparative purposes. Nest box measures were plotted for various canyon segments in Figures E-1.2-23 to E-1.2-28. Significant differences were observed between canyon and reference measurements of number of eggs hatched and the number and percent of birds fledged. The number and percent of birds fledged in Twomile Canyon were also statistically greater than reference measurements. Upper Pajarito Canyon measurements of the number of birds fledged were also significantly greater than reference. Measurements of number and percent eggs hatched and percent fledged did not differ significantly among remaining canyons and reference locations. No differences were observed between locations in different parts of the Pajarito watershed (upper Pajarito, Twomile, Threemile, and lower Pajarito), other locations, and reference measurements in terms of clutch size, number or percent eggs hatched, or percent females observed. In summary, none of the canyon segment nest box measures showed statistical decreases relative to reference site levels; therefore, there is no evidence of impairment of nesting success at Laboratory locations relative to reference locations.

Reach. For the Pajarito watershed, nest box observations were analyzed between reaches. Reference site measurements were also plotted for comparison. Where only one or two observations were available for a given reach, the reach was excluded from the plot (e.g., reach PA-4). Nest box measures were plotted for various canyon segments in Figures E-1.2-29 to E-1.2-34. Nest box measurements were compared between reaches of the Pajarito watershed. Some nest boxes were not located in a designated reach the Pajarito watershed and were labeled as “no reach” for analysis. Significant differences between reach and reference location measurements were observed for the number and percent of birds fledged. The number and percent of birds fledged were significantly higher than reference in reach TWSE-1W. The number and percent of birds fledged and the number of eggs hatched did not differ significantly among other reaches and reference. No significant differences between the Pajarito watershed reaches and reference were observed between nest box measurements in terms of clutch size, percent eggs hatched, or percent females. In summary, none of the reach nest box measures showed statistical decreases relative to reference site levels and therefore no evidence for impairment of nesting success at Laboratory locations relative to reference locations.

E-1.3 Earthworm Bioassay Results versus Confounding Factors and COPECs

To test for relationships of earthworm survival or growth to confounding factors or COPECs, scatter plots and linear regression analyses were prepared (Figures-E-1.3-1 to E-1.3-22). The plots show if there are relationships of the bioassay results with confounding factors or COPECs for the 11 samples tested with earthworm bioaccumulation test. The only statistically significant relationship was between increased earthworm survival and decreased levels of organic matter.

E-1.4 Seedling Germination Test Results versus Confounding Factors and COPECs

Levels of nutrients in soil exert a strong influence on germination and growth of plants. The pH of soil affects the availability of many nutrients to plants. Soil nutrient parameters and pH values were therefore measured in the soil samples from the Pajarito watershed used in the plant laboratory toxicity test. To test for relationships of seedling germination (survival) or growth to confounding factors or COPECs, scatter plots and linear regression analyses were prepared (Figures E-1.4-1 to E-1.4-57). The plots show if there are relationships of the bioassay results with confounding factors or COPECs for the 12 samples tested with seedling germination test. No statistically significant relationships were noted ($p > 0.05$).

E-1.5 *Chironomus tentans* Toxicity Test Results versus Confounding Factors and COPECs

Particle size and other sediment properties can affect the survival and growth of *Chironomus tentans* (chironomid, Family Chironomidae) larvae. Figures E-1.5-1 to E-1.5-12 show the relationships of chironomid survival and measures of growth versus confounding factors for the combined sets of toxicity test results from the watersheds of Los Alamos and Pueblo (LAP), Mortandad (MO), Pajarito (PA), and reference sites. There are some statistically significant relationships ($p < 0.05$) between sediment texture (e.g., fraction silt-sized particles) and growth.

Figures E-1.5-13 to E-1.5-30 show the relationships of chironomid survival and measures of growth versus COPECs for the Pajarito toxicity tests only. No statistically significant relationships with COPECs were found ($p > 0.05$).

E-2.0 SUPPORTING INFORMATION FOR THE HUMAN HEALTH RISK ASSESSMENT

This section provides human health exposure parameters and toxicity information, exposure point concentrations (EPCs), and results for the supplemental human health risk scenario (residential).

E-2.1 Exposure Parameters and Toxicity Information

Exposure parameters used to calculate soil screening levels (SSLs) and screening action levels (SALs) are provided in Table E-2.1-1 (SSLs for chemicals), Table E-2.1-2 (recreational [trail user] SALs for radionuclides), Table E-2.1-3 (surface water ingestion for SSLs for chemicals), and Table E-2.1-4 (residential SALs for radionuclides). Toxicity information for chemicals of potential concern (COPCs) that had screening levels calculated is provided in Table E-2.1-5 (chemicals) and Table E-2.1-6 (radionuclides).

E-2.2 Methods Used to Calculate Exposure Point Concentrations for Sediment

This section provides information on the statistical methods used to calculate EPCs of COPCs for the human health risk assessment.

The sample results for COPCs fall into three general categories. The first consists of COPCs detected in all of the investigation samples for a data subset or COPCs (radionuclides) that are not censored at the detection limit and that are reported as the actual measurement value from the instrument with a nondetect qualifier. The second includes inorganic or organic COPCs for which the data are a mixture of detected and nondetected values for a data subset. These data are censored at the detection limits for the nondetect values and are reported as the detection limit with a nondetect qualifier. For inorganic and organic chemicals, an approach to representing the censored nondetect values in the calculation of 95% upper confidence limits (UCLs) is needed. The third category is either an extreme case of the second category where the number of nondetects (the rate of censorship) is so high that methods for the second category are unreliable, or the data set is too small to calculate a 95% UCL. Section E-2.2.1 describes the methods used to analyze data that fall into the above three categories. The calculated UCLs and EPCs for sediment are presented in Table E-2.2-1.

E-2.2.1 Calculating UCLs

The statistical methods used to calculate 95% UCLs are generally consistent with U.S. Environmental Protection Agency (EPA) guidance (EPA 1989, 08021) and ProUCL (EPA 2003, 084461), the EPA public domain software provided for estimating UCLs to use as representative concentrations in risk assessments. Many of the data sets for sediment investigation reaches and water sampling locations are censored at the detection limits, but the ProUCL software does not include methods for censored data. Consequently, methods for calculating 95% UCLs deviated from ProUCL when professional judgment indicated that the ProUCL methods were inadequate for the data.

The first step in calculating a 95% UCL is to determine whether the data fit a probability distribution. The ProUCL software assesses normal and lognormal distributions. The probability plot Shapiro Wilk W-test is used to compare the data for an analyte from a sediment investigation reach or a water-sampling location with normal and log normal distributions. The possible outcomes and UCL calculation approaches are as follows:

- The data show a normal distribution; normal distribution methods are used.
- The data show a lognormal distribution; lognormal distribution methods are used.
- The data are not different from either distribution; normal distribution methods are used.
- The data are different from both distributions; the Chebyshev method is used.
- Insufficient data are available to evaluate the distribution; nonparametric methods are used.
- Two or fewer results are available; the maximum detected concentration is used.

When the calculated UCLs exceed the maximum value for the data, the maximum value is used instead of the 95% UCL. This approach is consistent with EPA guidance (EPA 1989, 08021).

The normal distribution method is a 95% UCL calculated using the arithmetic average, the standard error of the mean, and the Student's t-value for $n-1$ degrees of freedom (e.g., Gilbert 1987, 056179).

The lognormal 95% UCL method is calculated using the Land H -statistic (Gilbert 1987, 056179, pp. 169-170). This method has been criticized for providing large values for UCLs when the data are from a mixture of distributions or the data set has numerous outlier values (EPA 2003, 084461). However, in this report this method was used because it tends to generate larger UCLs when the data do not fit a lognormal distribution very well. Therefore, the outcome overestimates risk. The lognormal mean and variance are calculated using lognormal equations (minimum variance unbiased estimators) described in Gilbert (1987, 056179, pp. 165-167).

The Chebyshev method is recommended in the ProUCL manual for data that do not fit a normal or lognormal distribution. The standard error of the mean is multiplied by a value that is related to the confidence level for the interval. The methodology is documented in the ProUCL user's guide (EPA 2003, 084461).

E-2.2.2 Calculating UCLs with Uncensored Data

Calculating UCLs when all data are detected or when nondetects are not censored requires using the Shapiro Wilk test to determine whether the data fit a normal or lognormal probability distribution and then calculating the appropriate UCL. The radionuclides are not censored and nondetects are reported as positive or negative values as calculated by the laboratory instrument. The negative values are adjusted to values between zero and the smallest reported positive value. The application of methods for calculating a UCL in this report has been constrained to data sets with at least three values.

E.2.2-3 Calculating UCLs with Censored Data

A variety of methods can be used to address nondetect values in a data set. Some of the most widely used are substitutions of the nondetects with the detection limit, half the detection limit, or zero. While these substitution methods are simple, they do not have a statistical basis and can provide erroneous results, over- or underestimating the UCL. The most serious errors with substitution methods are in biasing the estimate of the variance, which can result in a low-biased UCL. Helsel and Cohn (1988, 082912) conducted simulation studies to compare the results of substitution methods against probability plotting methods and maximum likelihood methods for estimating values to replace the nondetects. Their results indicate that probability plotting methods provide the most accurate data summaries for typical environmental data with characteristics such as outliers and skewed distributions.

In this report, the probability plotting method of Helsel and Cohn (1988, 082912) was selected for working with censored data. It provides the best overall performance in estimating fill-in values for nondetects in simulation studies, especially when there is information on the data distribution. It also performs well when the parent distributions of the simulation data sets are very different from the lognormal distribution used to estimate the values for the nondetect values. Another important attribute of the method is that it accommodates data with multiple detection limits. Finally, even when the detected data are highly variable, including outliers, and are not associated with any particular distribution, the estimated nondetect values are constrained to fall between the detection limit and zero. The estimated nondetect values may not always be optimal, but they are also not likely to cause large biases in the estimates of the average and variance for the data set.

The conceptual approach for the probability plotting method starts by assigning exceedance probabilities to each of the detected values based upon its relative magnitude, after which the nondetect values are assigned exceedance probabilities between zero and the detection limit. If each detection limit has a single value, then the assigned probability is half of the detection limit probability. For example, if there are three detection limits with the same value, then the x-axis from zero to the detection limit probability is divided into four segments, and each detection limit is assigned a value at one of the three break points (1/4, 1/2, and 3/4 of the detection limit probability). The spreading of nondetects over a probability range is how the probability plotting method differs from simple substitution methods, where the detection limit, half the detection limit, or zero would be used for all three values. The exceedance probabilities for the data and nondetect values are converted to proportions of the normal distribution, or z-scores. A regression analysis is performed on the log transformed detected data versus their z-scores. The regression line fit is used to estimate log-concentration values for the nondetect z-scores. These values

are back-transformed to original units and combined with the detected values in original units for estimating summary statistics and 95% UCLs.

The extrapolated nondetect values distribute estimates for the detection limits over a range of exceedance probabilities. The values are not intended to be specific estimates for what the sample concentration should have been. The assigned values can be used for summary statistics, such as averages and 95% UCLs but not as individual replacement values for sample results. The method is considered to be semi-nonparametric because the detected values are used without making an assumption about the data distribution. The nondetect values are assumed to come from a lognormal distribution.

Once the nondetect data are replaced with estimated values from the probability plotting method, the combined data set of original detected values and estimates for the nondetects are evaluated with the Shapiro Wilk test for their fit to a normal or lognormal distribution. Normal distribution methods are used to estimate the average and UCL for data that fit a normal distribution. The Land method described by Gilbert (1987, 056179) is used for data that are distributed lognormally. When the data fit neither of these distributions, the method based upon the Chebyshev theorem is used to estimate a 95% UCL (EPA 2003, 84461). An example is provided in Appendix E of the "Los Alamos and Pueblo Canyon Investigation Report" (LANL 2004, 087390, pp. E-5– E-6).

E-2.3 Calculating Exposure Point Concentrations for COPCs in Surface Water

Results from water samples collected before 2003 were excluded. These results are not used in calculations because concentrations in older samples are not representative of current site conditions. Field duplicates (indicated by "FD" in the field QC type code column in Appendix C tables) were excluded. These results are from samples obtained for quality assurance/quality control (QA/QC) purposes and not as primary characterization data. Filtered surface water samples were excluded and unfiltered surface water concentrations were used to represent surface water that would be encountered by a trail user in the canyon. Unfiltered samples provide a conservative estimate in that concentrations in unfiltered samples are typically larger than in filtered samples.

Surface water data were evaluated for each sampling location; surface water sample locations were associated with a sediment investigation reach. Methods for calculating representative concentrations for surface water follows the protocols outlined in Section E-2.2. Table E-2.3-1 2 presents the UCLs and EPCs for surface water COPCs retained for the human health risk assessment.

E-2.4 Supplemental Human Health Risk Scenario

The SSLs and SALs used for the supplemental scenario are provided in Table E-2.4-1. The risk assessment results for the residential scenario are provided in Table E-2.4-2. The ratios and sum of fraction (SOF) values for the residential scenario are provided in Table E-2.4-3. Representative sediment concentrations used for this analysis are provided in Table 8.2-14 and E-2.2-1.

The sample results for COPCs fall into three general categories. The first consists of COPCs detected in all of the investigation samples for a data subset or COPCs (radionuclides) that are not censored at the detection limit and that are reported as the actual measurement value from the instrument with a nondetect qualifier. The second includes inorganic or organic COPCs for which the data are a mixture of detected and nondetected values for a data subset. These data are censored at the detection limits for the nondetect values and are reported as the detection limit with a nondetect qualifier. For inorganic and organic chemicals, an approach is needed to represent the censored nondetect values in the calculation of 95% upper confidence limits (UCLs). The third category is either an extreme case of the second

category where the number of nondetects (the rate of censorship) is so high that methods for the second category are unreliable, or the data set is too small to calculate a 95% UCL. Section E-2.2.1 describes the methods used to analyze data that fall into the above three categories. The calculated UCLs and EPCs for sediment are presented in Tables 8.2-14 and E-2.2-1.

E-3.0 REFERENCES

The following list includes all documents cited in this appendix. Parenthetical information following each reference provides the author(s), publication date, and ER ID number. This information is also included in text citations. ER ID numbers are assigned by the Environmental Programs Directorate's Records Processing Facility (RPF) and are used to locate the document at the RPF and, where applicable, in the master reference set.

Copies of the master reference set are maintained at the New Mexico Environment Department Hazardous Waste Bureau; U.S. Department of Energy—Los Alamos Site Office; EPA, Region 6; and the Directorate. The set was developed to ensure that the administrative authority has all material needed to review this document, and it is updated with every document submitted to the administrative authority. Documents previously submitted to the administrative authority are not included.

EPA (U.S. Environmental Protection Agency), December 1989. "Risk Assessment Guidance for Superfund, Volume I: Human Health Evaluation Manual (Part A), Interim Final," EPA/540/1-89/002, Office of Emergency and Remedial Response, Washington, D.C. (EPA 1989, 008021)

EPA (U.S. Environmental Protection Agency), August 1997. "Exposure Factors Handbook, Volume I, General Factors," EPA/600/P-95/002Fa, Office of Research and Development, Washington, D.C. (EPA 1997, 066596)

EPA (U.S. Environmental Protection Agency), June 2003. "ProUCL User's Guide," NERL-LV 02-049, Las Vegas, Nevada. (EPA 2003, 084461)

EPA (U.S. Environmental Protection Agency), October 2004. "EPA Region 9 Preliminary Remediation Goals Table," San Francisco, California. (EPA 2004, 093663)

Gilbert, R.O., 1987. *Statistical Methods for Environmental Pollution Monitoring*, Van Nostrand Reinhold, New York, New York. (Gilbert 1987, 056179)

Helsel, D.R., and T.A. Cohn, 1988. "Estimation of Descriptive Statistics for Multiply Censored Water Quality Data," *Water Resources Research*, Vol. 24, No. 12, pp. 1997-2004. (Helsel and Cohn 1988, 082912)

LANL (Los Alamos National Laboratory), April 2004. "Los Alamos and Pueblo Canyons Investigation Report," Los Alamos National Laboratory document LA-UR-04-2714, Los Alamos, New Mexico. (LANL 2004, 087390)

LANL (Los Alamos National Laboratory), November 2004. "Draft Technical Approach for Calculating Recreational Soil Screening Levels for Chemicals," Los Alamos National Laboratory document LA-UR-04-7743, Los Alamos, New Mexico. (LANL 2004, 087800)

EPA (U.S. Environmental Protection Agency), December 1989. "Risk Assessment Guidance for Superfund, Volume I: Human Health Evaluation Manual (Part A), Interim Final," EPA/540/1-89/002, Office of Emergency and Remedial Response, Washington, D.C. (EPA 1989, 008021)

- EPA (U.S. Environmental Protection Agency), August 1997. "Exposure Factors Handbook, Volume I, General Factors," EPA/600/P-95/002Fa, Office of Research and Development, Washington, D.C. (EPA 1997, 066596)
- EPA (U.S. Environmental Protection Agency), August 1997. "Exposure Factors Handbook, Volume III, Activity Factors," EPA/600/P-95/002Fc, Office of Research and Development, Washington, D.C. (EPA 1997, 066598)
- EPA (U.S. Environmental Protection Agency), June 2003. "ProUCL User's Guide," NERL-LV 02-049, Las Vegas, Nevada. (EPA 2003, 084461)
- EPA (U.S. Environmental Protection Agency), October 2004. "EPA Region 9 Preliminary Remediation Goals Table," San Francisco, California. (EPA 2004, 093663)
- Gilbert, R.O., 1987. *Statistical Methods for Environmental Pollution Monitoring*, Van Nostrand Reinhold, New York, New York. (Gilbert 1987, 056179)
- Health Canada (HC), 1995. "Radiological Characteristics". http://www.hc-sc.gc.ca/ewh-semt/pubs/water-eau/radiological_characteristics/index-eng.php#Application
- Helsel, D.R., and T.A. Cohn, 1988. "Estimation of Descriptive Statistics for Multiply Censored Water Quality Data," *Water Resources Research*, Vol. 24, No. 12, pp. 1997-2004. (Helsel and Cohn 1988, 082912)
- LANL (Los Alamos National Laboratory), November 2004. "Draft Technical Approach for Calculating Recreational Soil Screening Levels for Chemicals," Los Alamos National Laboratory document LA-UR-04-7743, Los Alamos, New Mexico. (LANL 2004, 087800)
- LANL (Los Alamos National Laboratory), April 2004. "Los Alamos and Pueblo Canyons Investigation Report," Los Alamos National Laboratory document LA-UR-04-2714, Los Alamos, New Mexico. (LANL 2004, 087390)
- LANL (Los Alamos National Laboratory), March 2005. "Human Health Risk-Based Screening Methodology, Revision 1," Los Alamos National Laboratory document LA-UR-04-8809, Los Alamos, New Mexico. (LANL 2005, 088494)
- LANL (Los Alamos National Laboratory), May 2005. "Derivation and Use of Radionuclide Screening Action Levels, Revision 1," Los Alamos National Laboratory document LA-UR-05-1849, Los Alamos, New Mexico. (LANL 2005, 088493)
- LANL (Los Alamos National Laboratory), September 2005. "Ecorisk Database (Release 2.2)," on CD, LA-UR-05-7424, Los Alamos National Laboratory, Los Alamos, New Mexico. (LANL 2005, 090032)
- LANL (Los Alamos National Laboratory), October 2006. "Mortandad Canyon Investigation Report," Los Alamos National Laboratory document LA-UR-06-6752, Los Alamos, New Mexico. (LANL 2006, 094161)
- NMED (New Mexico Environment Department), February 2004. "Technical Background Document for Development of Soil Screening Levels, Revision 2.0, Volume 1, Tier 1: Soil Screening Guidance Technical Background Document," New Mexico Environment Department, Hazardous Waste Bureau, Ground Water Quality Bureau and Voluntary Remediation Program, Santa Fe, New Mexico. (NMED 2004, 085615)

NMED (New Mexico Environment Department), August 2005. "Technical Background Document for Development of Soil Screening Levels, Revision 3.0, Volume 1, Tier 1: Soil Screening Guidance Technical Background Document," New Mexico Environment Department, Hazardous Waste Bureau and Ground Water Quality Bureau Voluntary Remediation Program, Santa Fe, New Mexico. (NMED 2005, 090802)

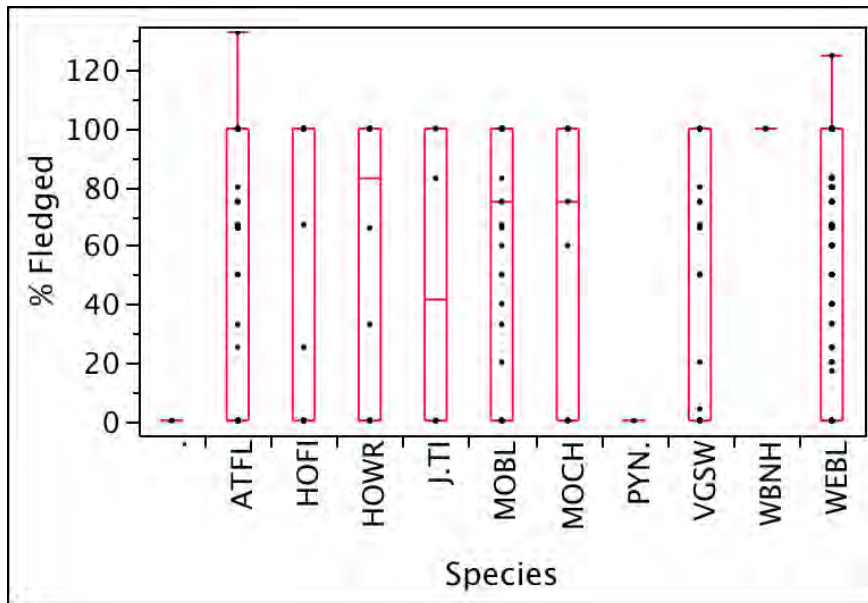

Figure E-1.2-1 Box plot comparing the percent fledged across avian species. ATFL = ash-throated flycatcher, HOFI = house finch, HOWR = house wren, J.TI = juniper titmouse, MOBL = mountain bluebird, MOCH = mountain chickadee, PYN. = pygmy nuthatch, VGSW = violet-green swallow, and WBNH = white-breasted nuthatch, WEBL = western bluebird.

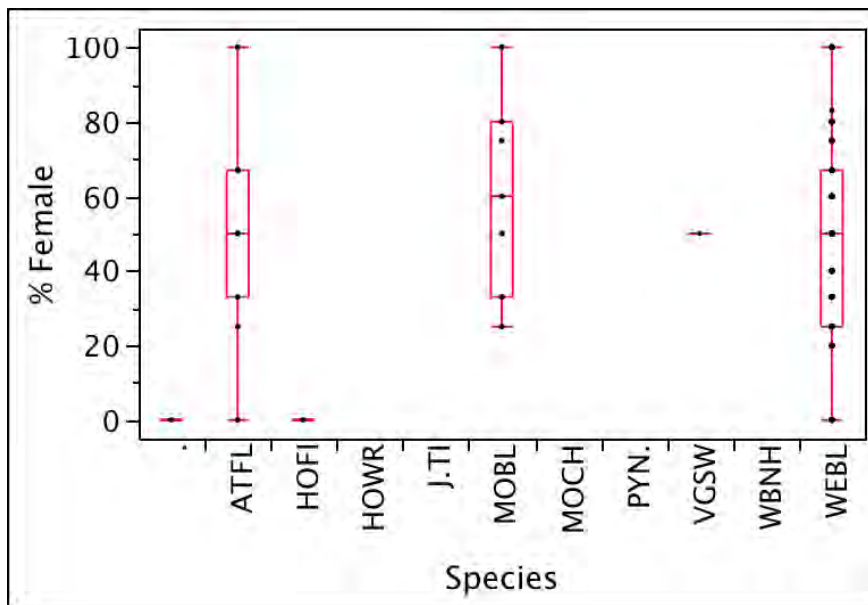

Figure E-1.2-2 Box plot comparing the percent female nestlings across avian species. ATFL = ash-throated flycatcher, HOFI = house finch, MOBL = mountain bluebird, VGSW = violet-green swallow, and WEBL = western bluebird.

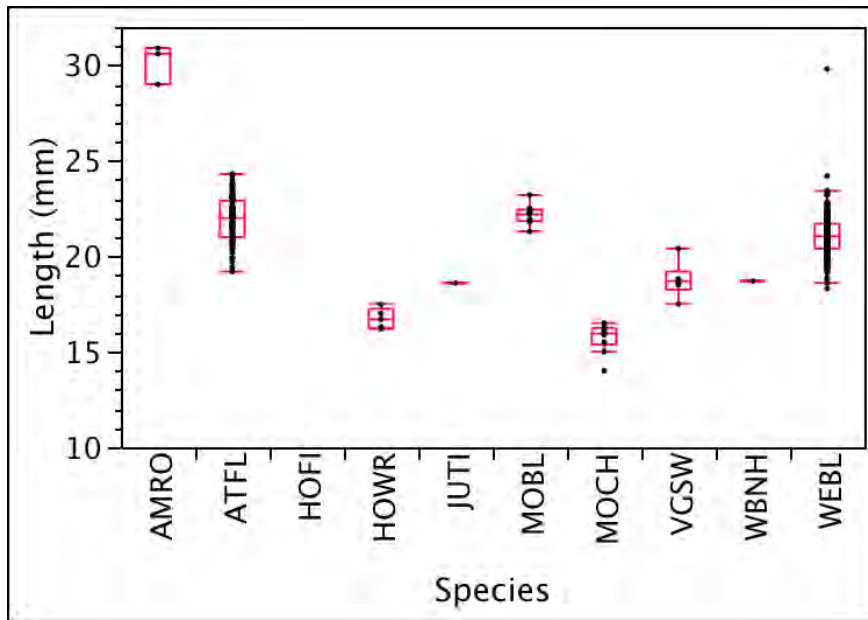

Figure E-1.2-3 Box plot comparing egg length across species. AMRO = American robin, ATFL = ash-throated flycatcher, HOFI = house finch, HOWR = house wren, JUTI = juniper titmouse, MOBL = mountain bluebird, MOCH = mountain chickadee, VGSW = violet-green swallow, WBNH = white-breasted nuthatch, and WEBL = western bluebird.

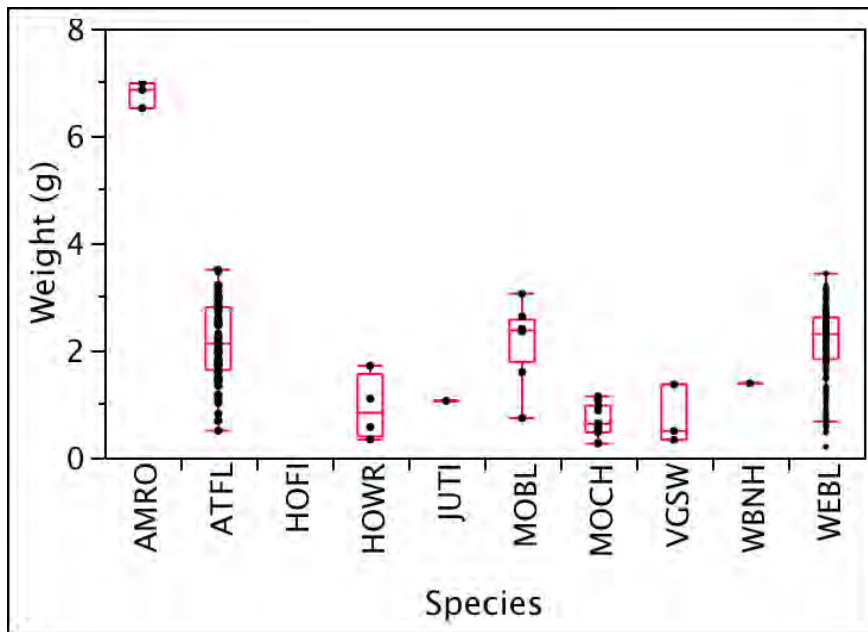

Figure E-1.2-4 Box plot comparing egg weight across species. AMRO = American robin, ATFL = ash-throated flycatcher, HOFI = house finch, HOWR = house wren, JUTI = juniper titmouse, MOBL = mountain bluebird, MOCH = mountain chickadee, VGSW = violet-green swallow, WBNH = white-breasted nuthatch, and WEBL = western bluebird.

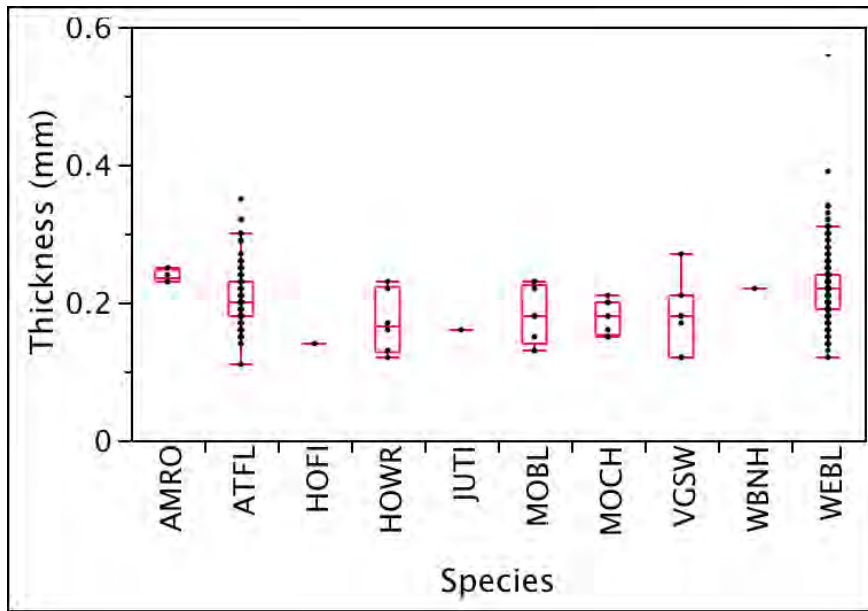

Figure E-1.2-5 Box plot comparing eggshell thickness across species. AMRO = American robin, ATFL = ash-throated flycatcher, HOFI = house finch, HOWR = house wren, JUTI = juniper titmouse, MOBL = mountain bluebird, MOCH = mountain chickadee, VGSW = violet-green swallow, WBNH = white-breasted nuthatch, and WEBL = western bluebird.

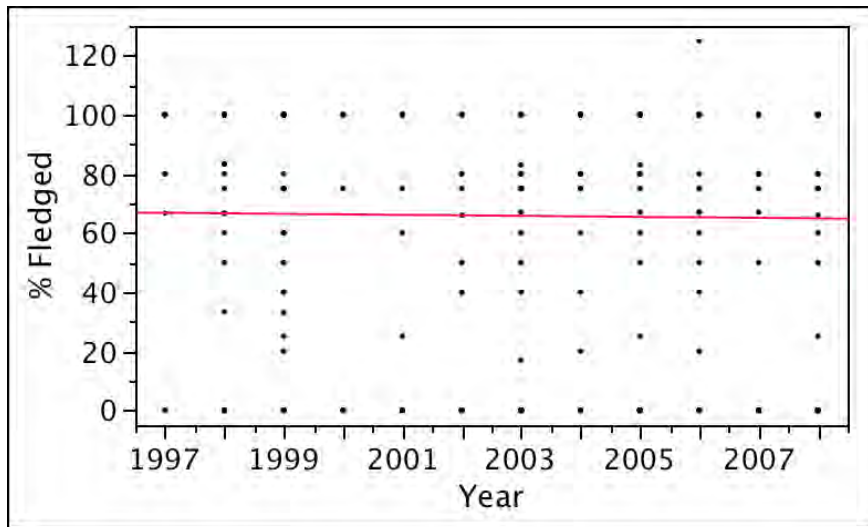

Figure E-1.2-6 Scatter plot of percent of nestlings fledged versus year for western bluebirds. The linear regression line explained variance is <1%, so it is not biologically relevant.

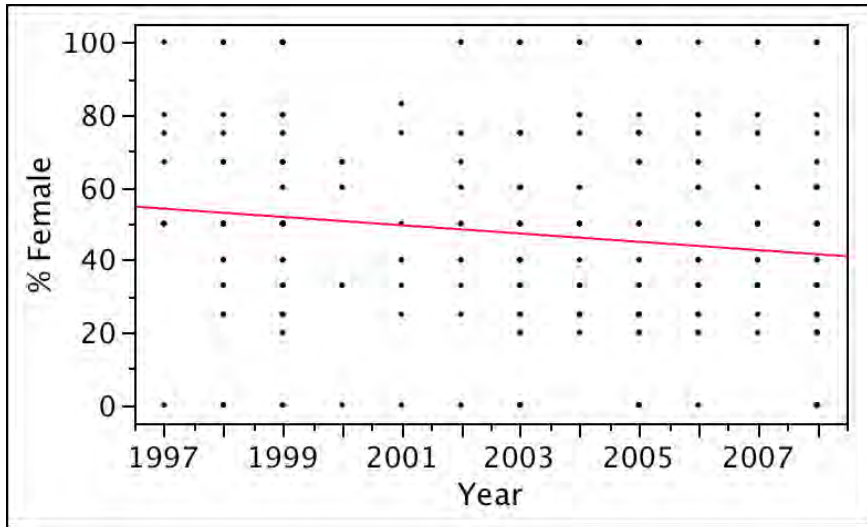

Figure E-1.2-7 Scatter plot of percent nestlings that are female versus year for western bluebirds. The linear regression line explained variance is 2%, so it is not biologically relevant.

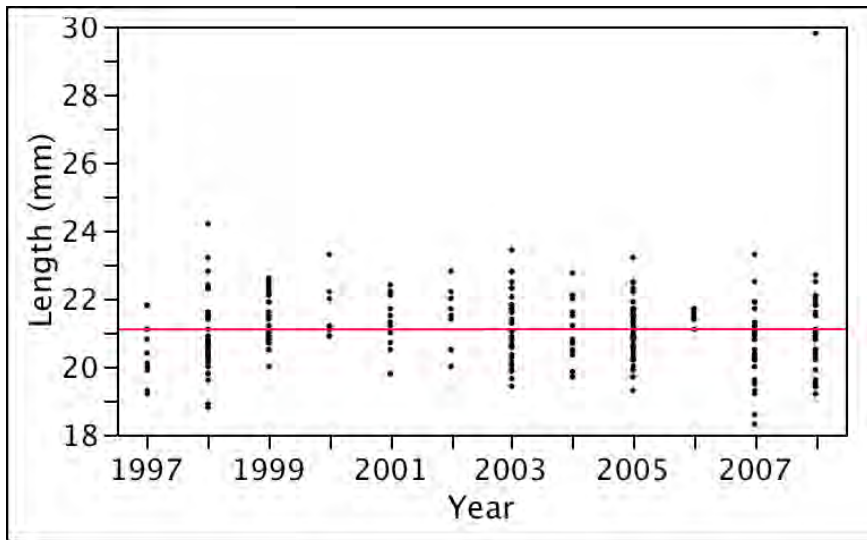

Figure E-1.2-8 Scatter plot of egg length versus year for western bluebirds. The linear regression line explained variance is <1%, so it is not biologically relevant.

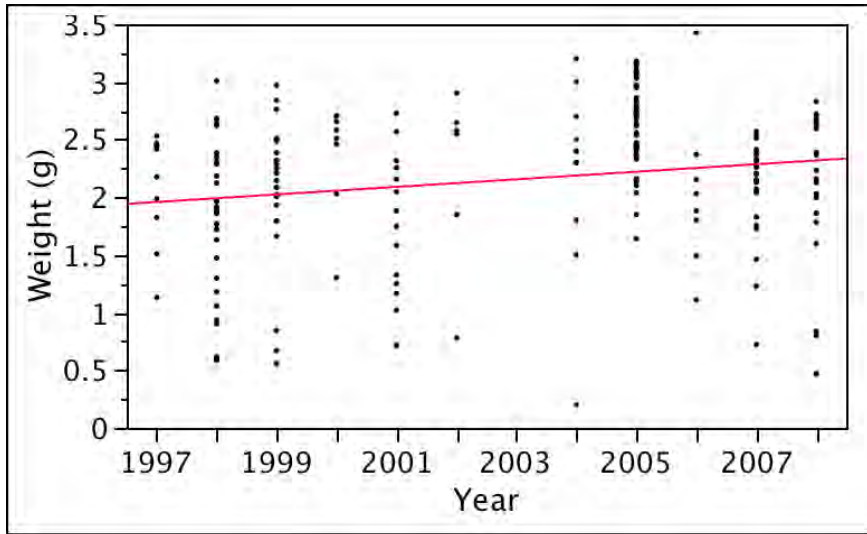

Figure E-1.2-9 Scatter plot of egg weight versus year for western bluebirds. The linear regression line explained variance is 3.5%, so it is not biologically relevant.

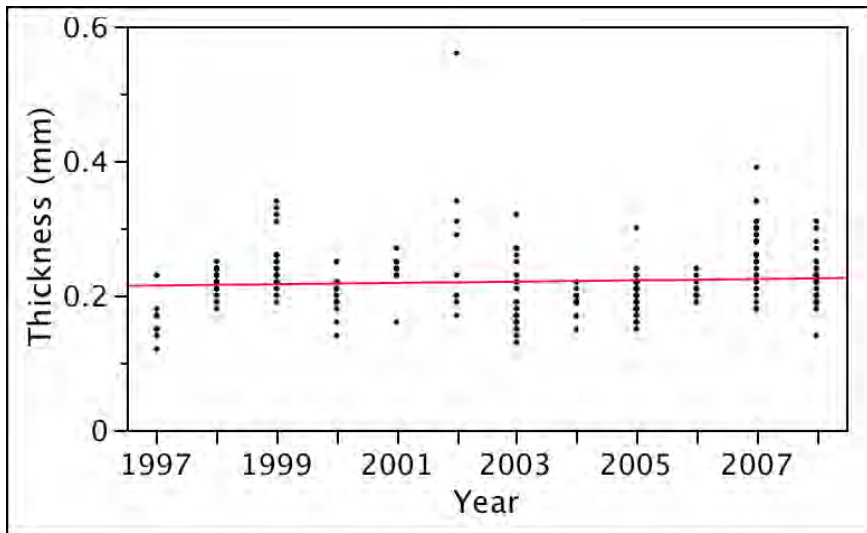

Figure E-1.2-10 Scatter plot of eggshell thickness versus year for western bluebirds. The linear regression line explained variance is <1%, so it is not biologically relevant.

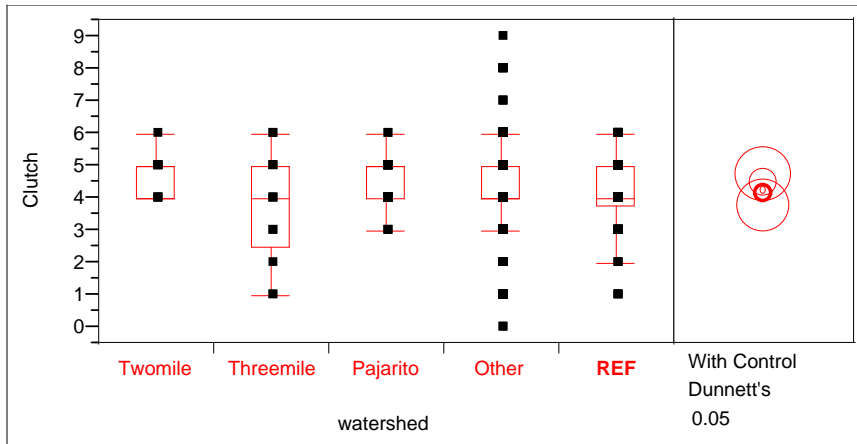

Figure E-1.2-11 Box plots of clutch size for all species by canyon

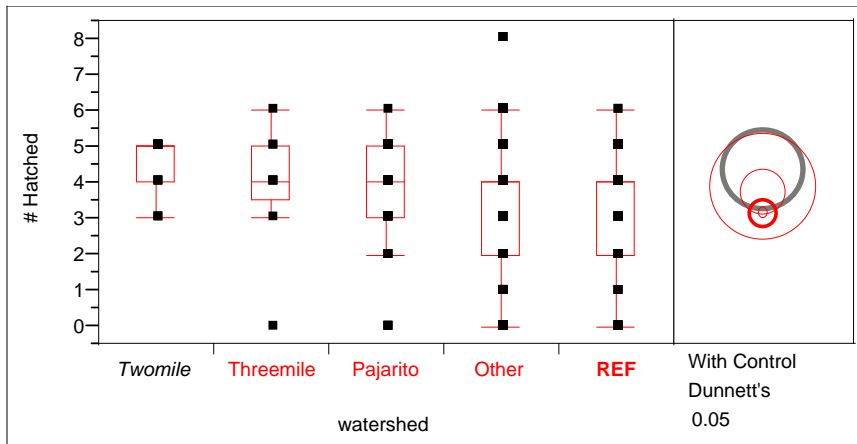

Figure E-1.2-12 Box plots of number hatched for all species by canyon

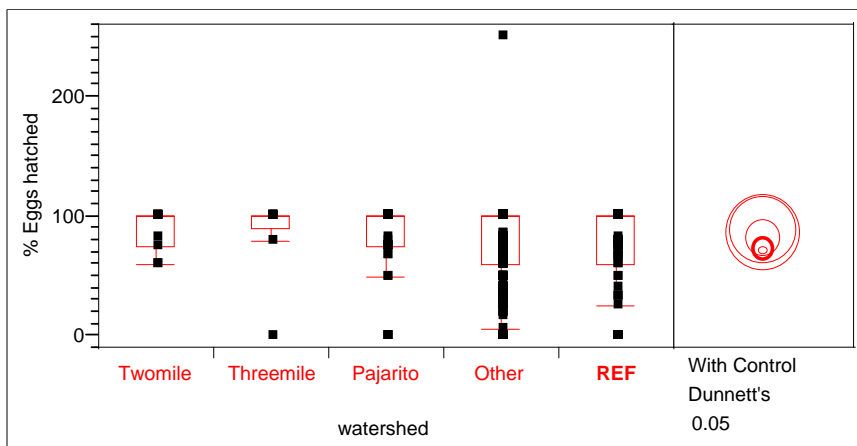

Figure E-1.2-13 Box plots of percentage eggs hatched for all species by canyon

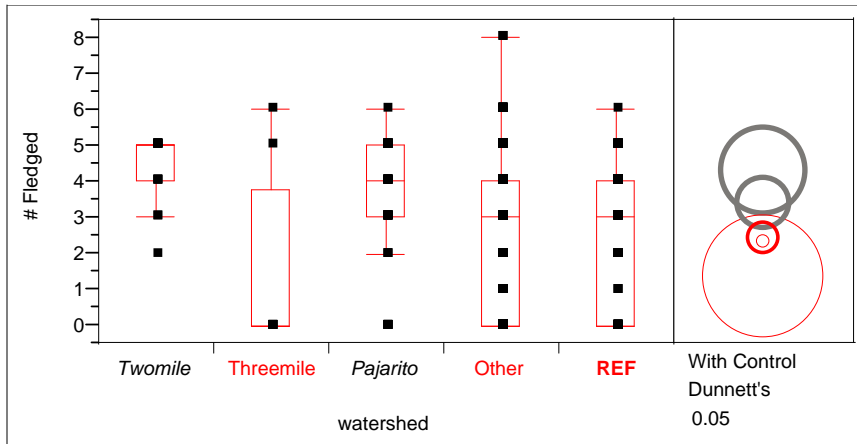

Figure E-1.2-14 Box plots of number fledged for all species by canyon

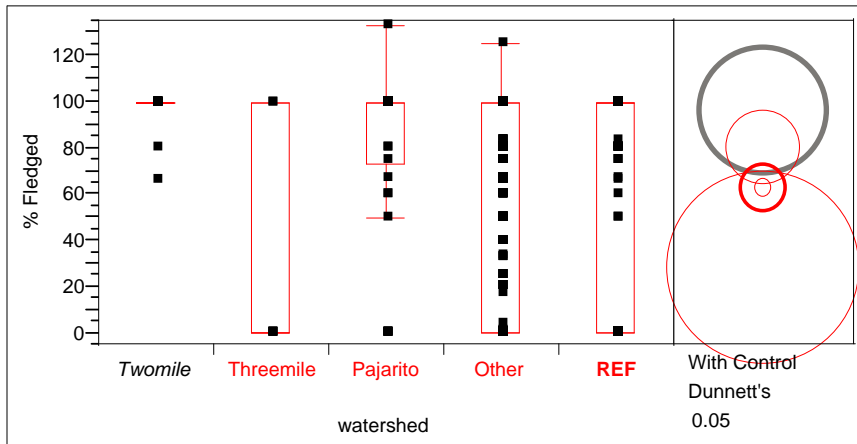

Figure E-1.2-15 Box plots of percentage fledged for all species by canyon

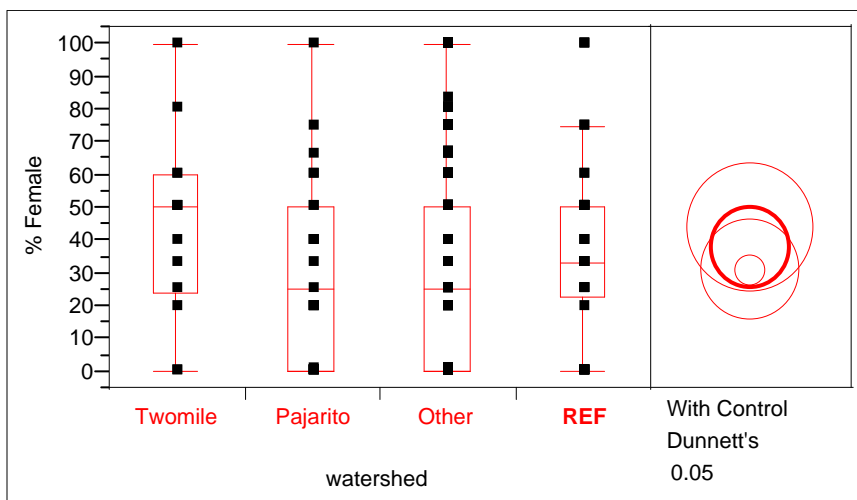

Figure E-1.2-16 Box plots of percentage female for all species by canyon

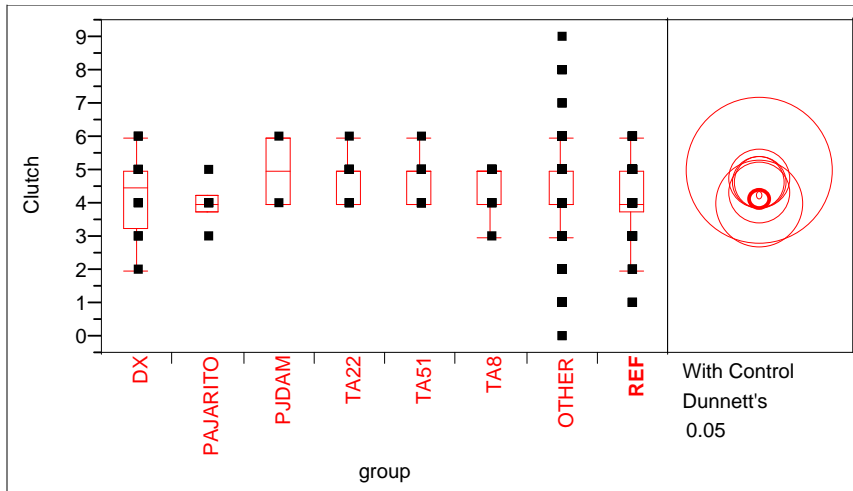

Figure E-1.2-17 Box plots of clutch size for all species by location group name

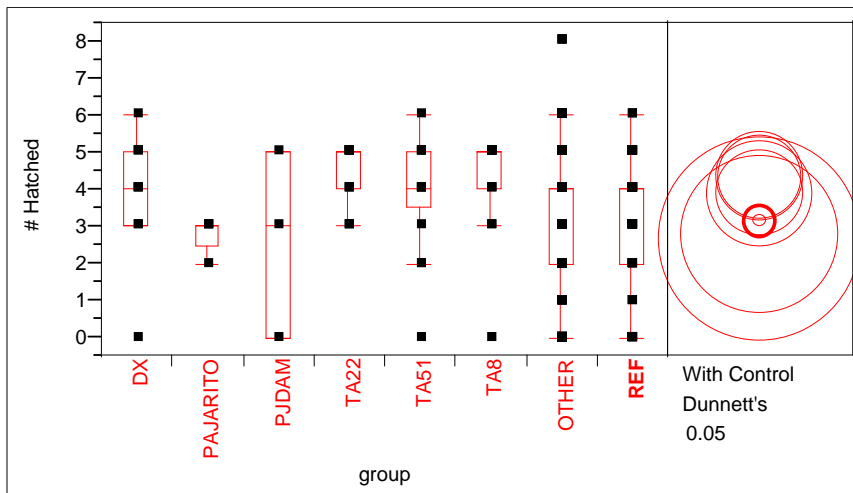

Figure E-1.2-18 Box plots of number hatched for all species by location group name

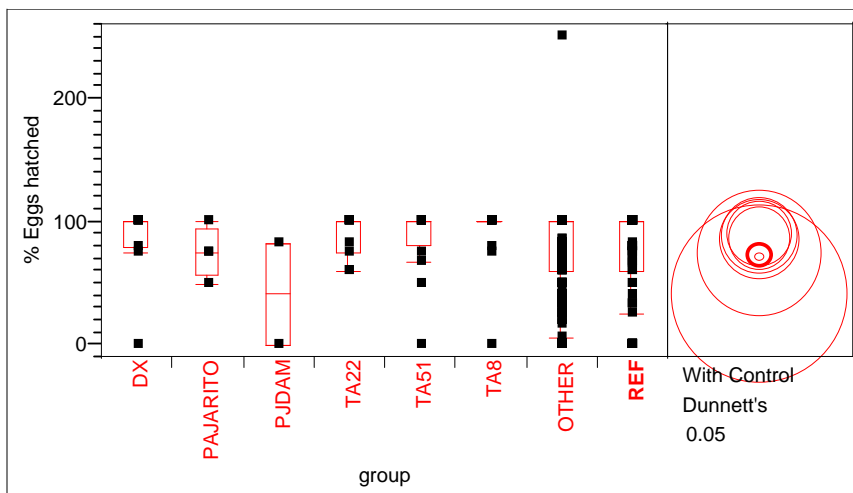

Figure E-1.2-19 Box plots of percentage hatched for all species by location group name

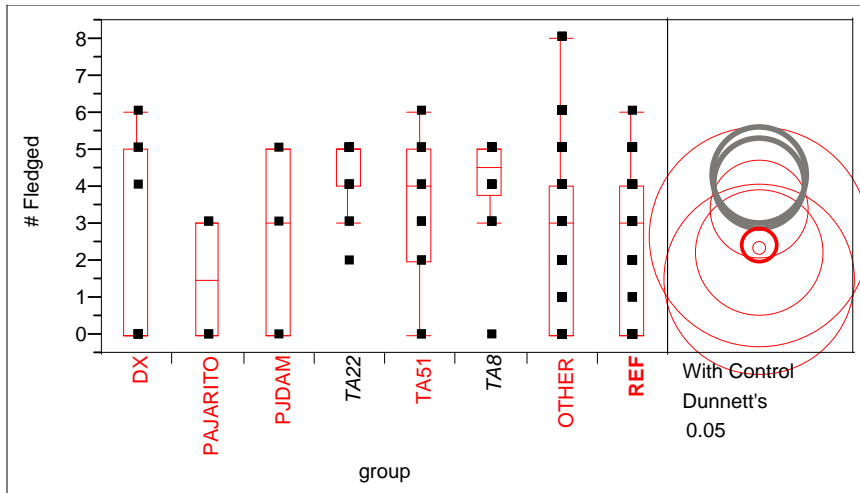

Figure E-1.2-20 Box plots of number fledged for all species by location group name

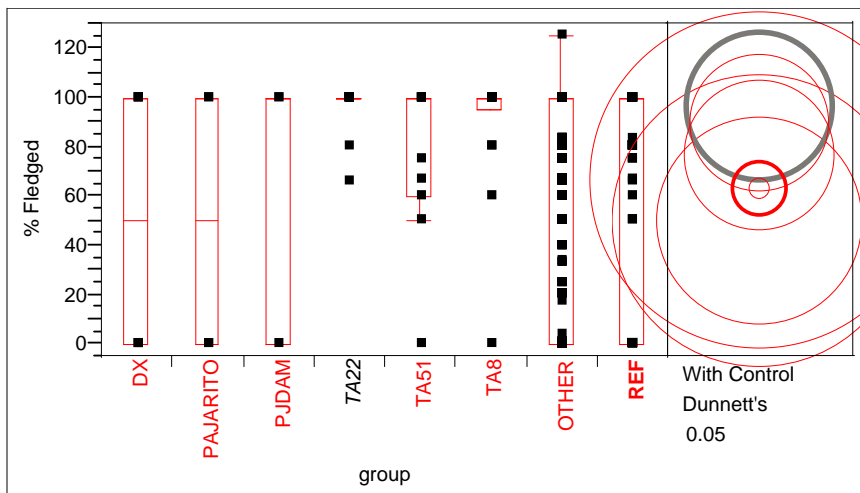

Figure E-1.2-21 Box plots of percentage fledged for all species by location group name

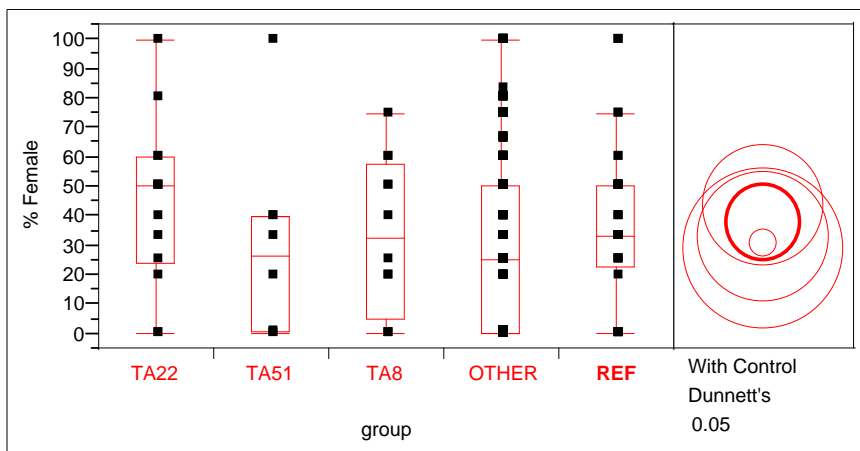

Figure E-1.2-22 Box plots of percentage female for all species by location group name

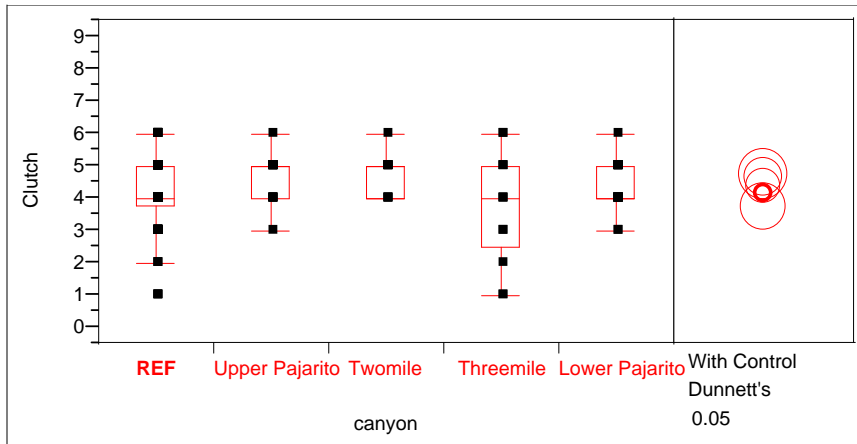

Figure E-1.2-23 Box plots of clutch size for all species by canyon segment

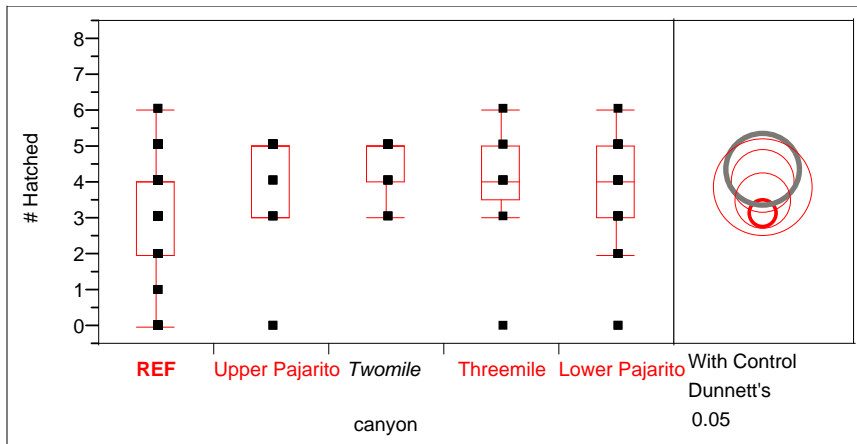

Figure E-1.2-24 Box plots of number hatched for all species by canyon segment

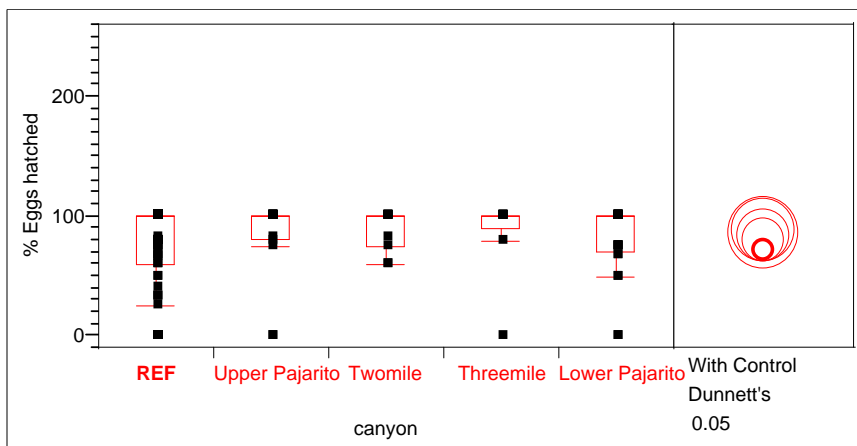

Figure E-1.2-25 Box plots of percentage hatched for all species by canyon segment

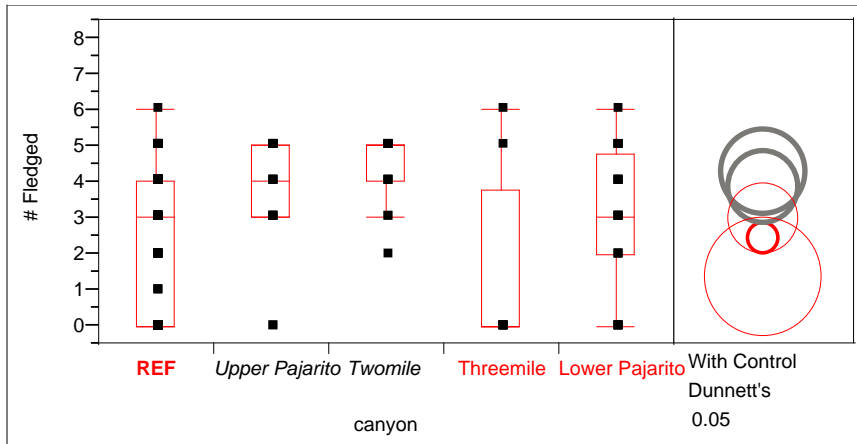

Figure E-1.2-26 Box plots of number fledged for all species by canyon segment

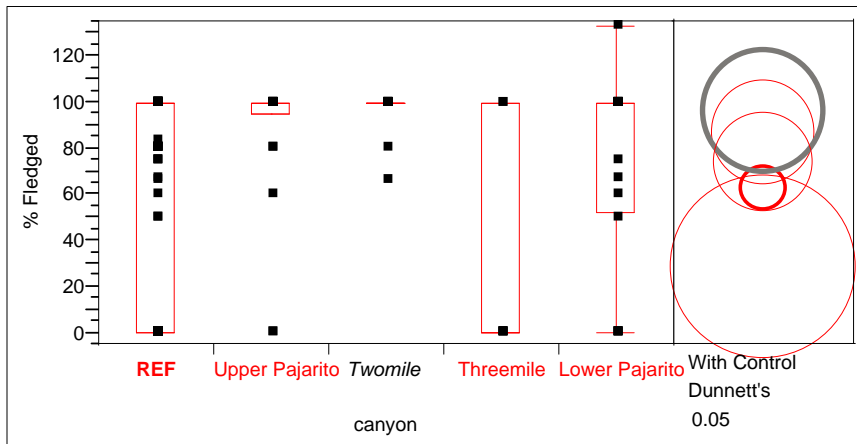

Figure E-1.2-27 Box plots of percentage fledged for all species by canyon segment

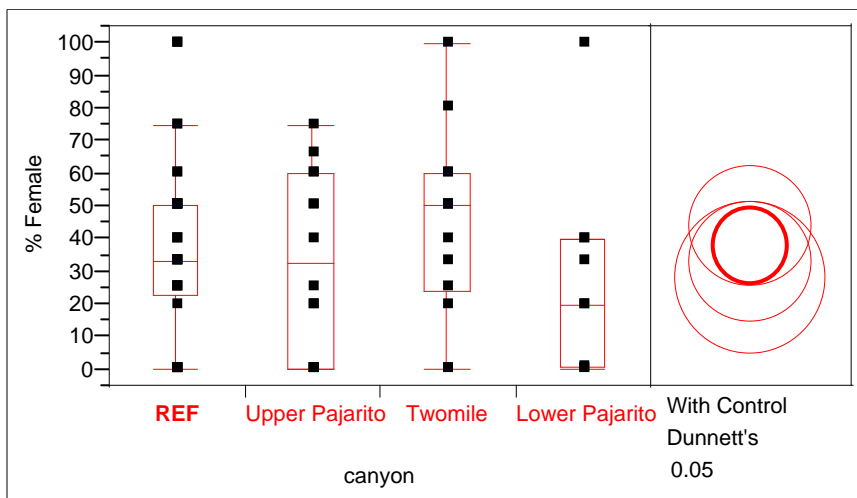

Figure E-1.2-28 Box plots of percentage female for all species by canyon segment

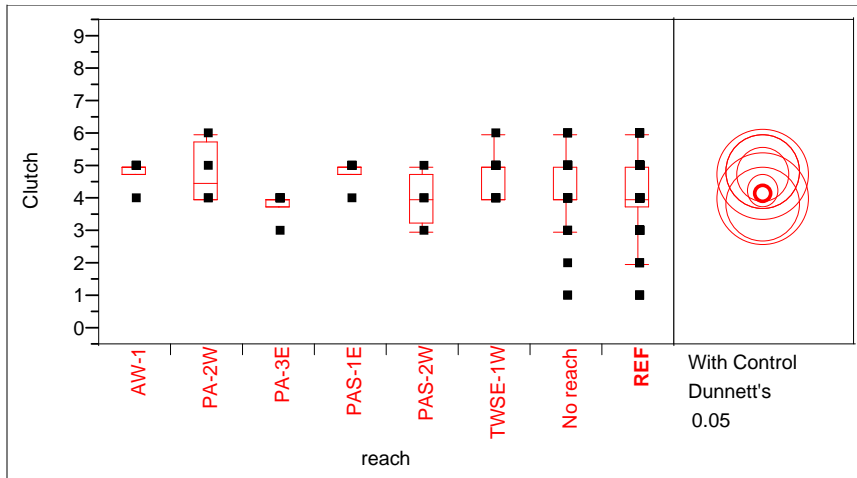

Figure E-1.2-29 Box plots of clutch size for all species by reach

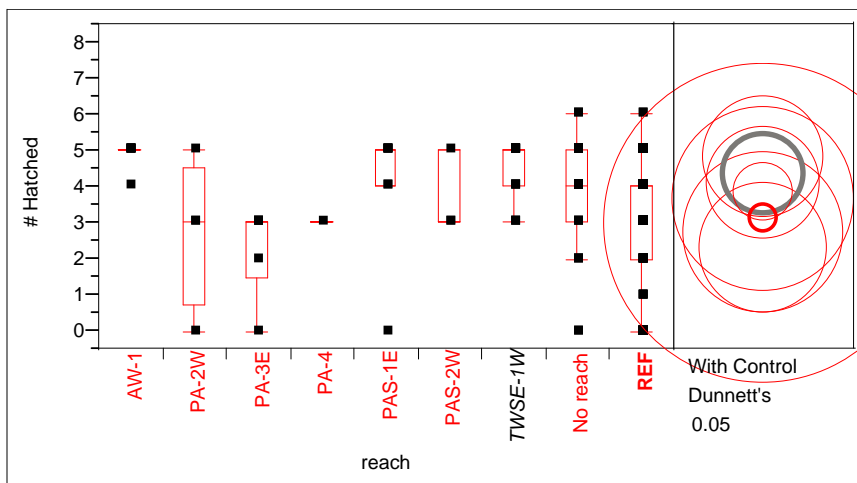

Figure E-1.2-30 Box plots of number hatched for all species by reach

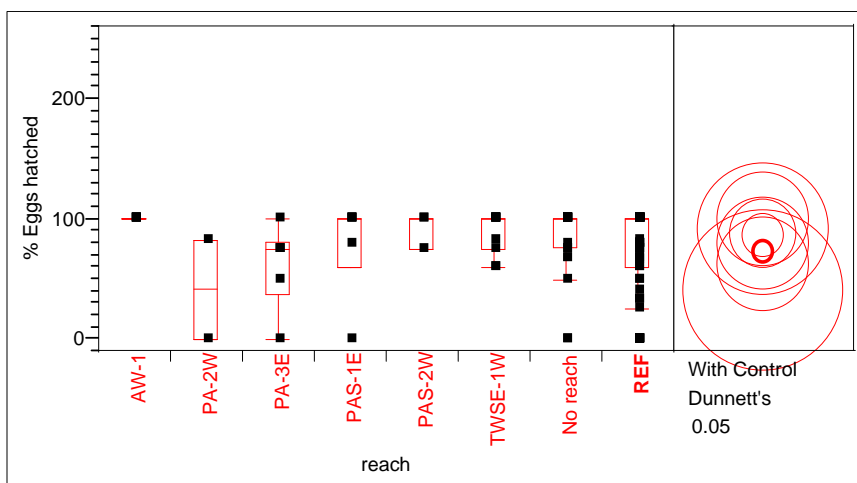

Figure E-1.2-31 Box plots of percentage hatched for all species by reach

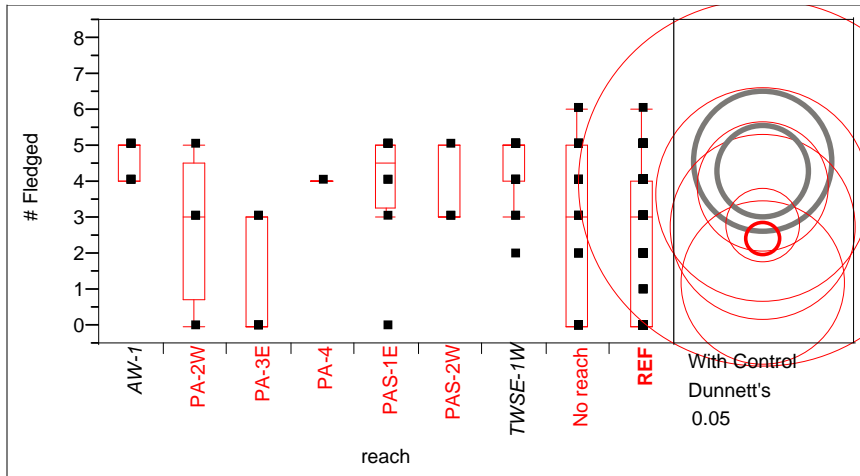

Figure E-1.2-32 Box plots of number fledged for all species by reach

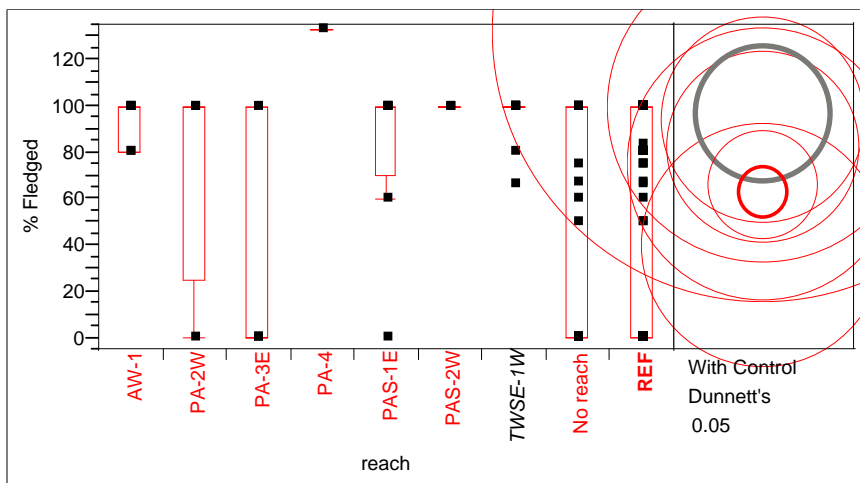

Figure E-1.2-33 Box plots of percentage fledged for all species by reach

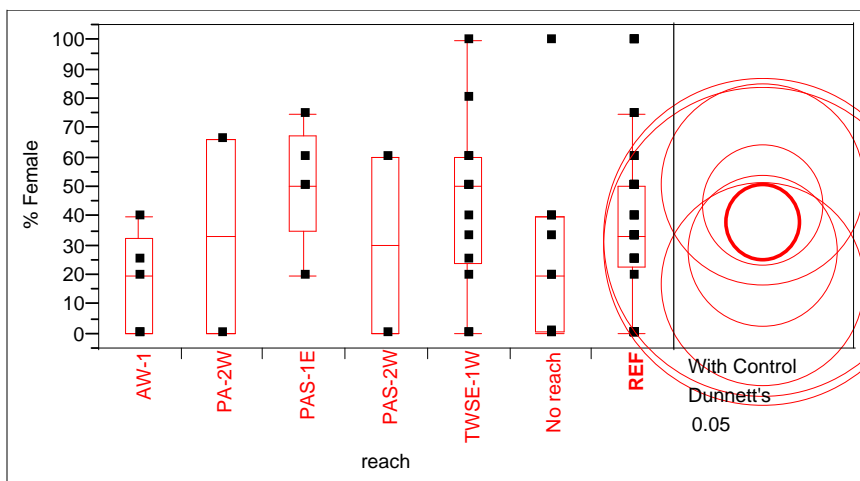

Figure E-1.2-34 Box plots of percentage female for all species by reach

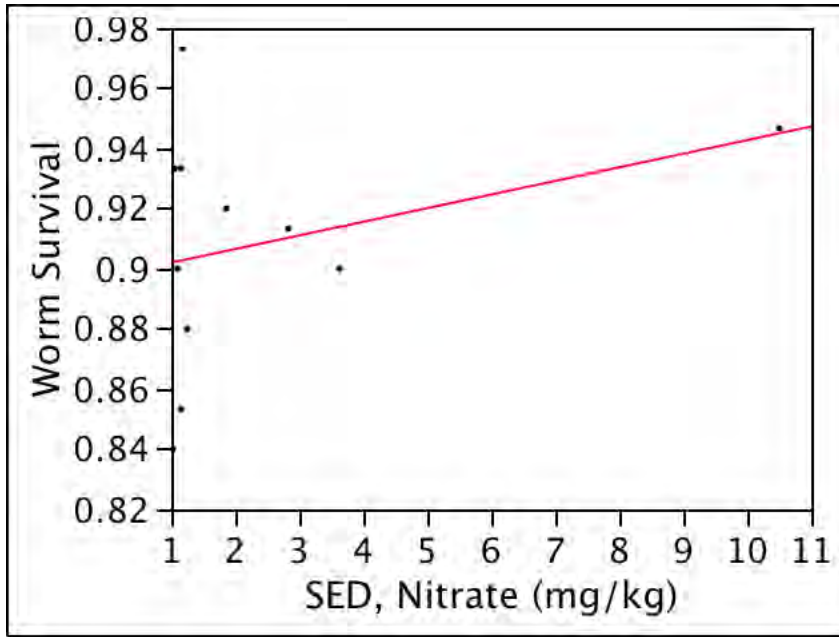

Figure E-1.3-1 Bivariate plot of worm survival versus nitrate (potential confounding factor).
Worm survival = $0.897 + 0.00453 \cdot \text{SED, nitrate}$; $r^2 = 0.103$; $n = 11$; $p = 0.336$.

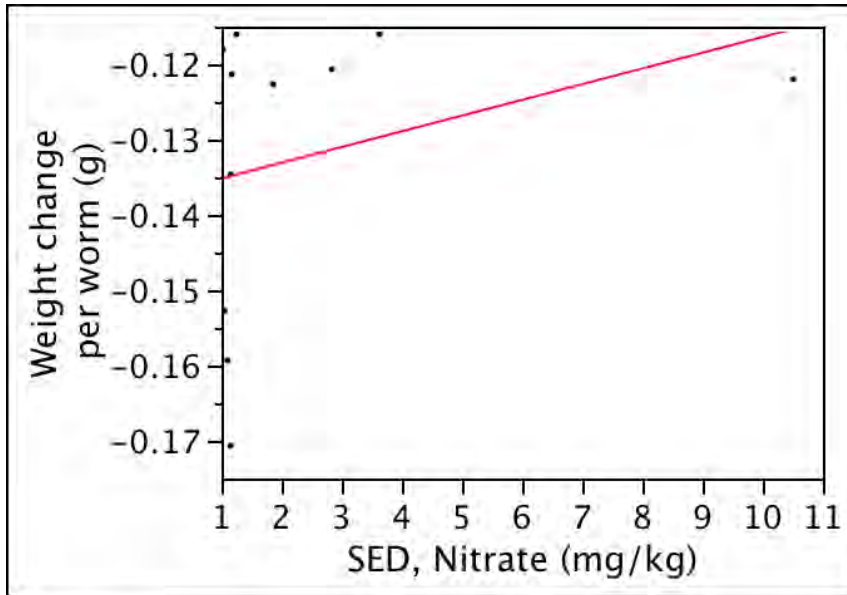

Figure E-1.3-2 Bivariate plot of worm growth versus nitrate (potential confounding factor).
Weight change per worm (g) = $-0.137 + 0.00209 \cdot \text{SED, nitrate}$; $r^2 = 0.090$; $n = 11$; $p = 0.370$.

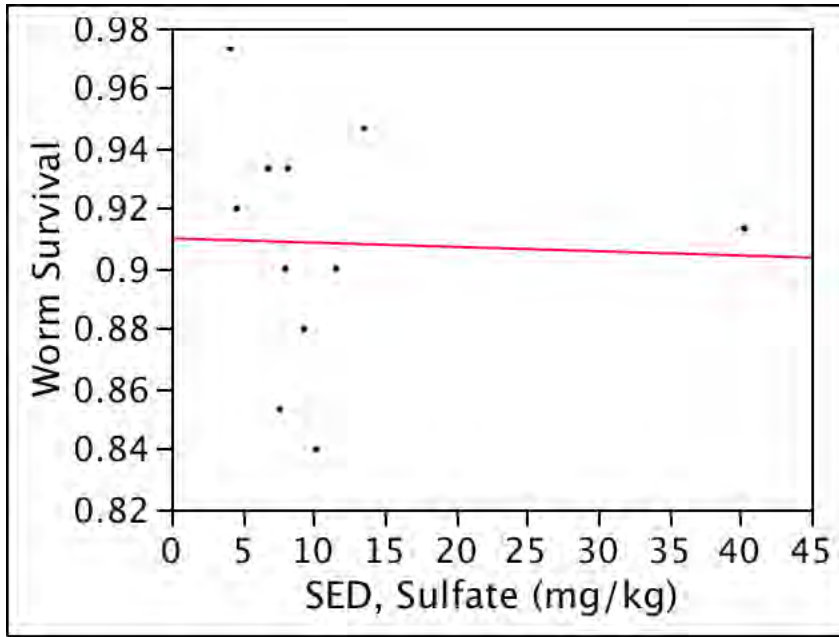

Figure E-1.3-3 Bivariate plot of worm survival versus sulfate (potential confounding factor).
Worm survival = 0.910 - 0.000143*SED, sulfate; r2 = 0.00130; n = 11; p = 0.916.

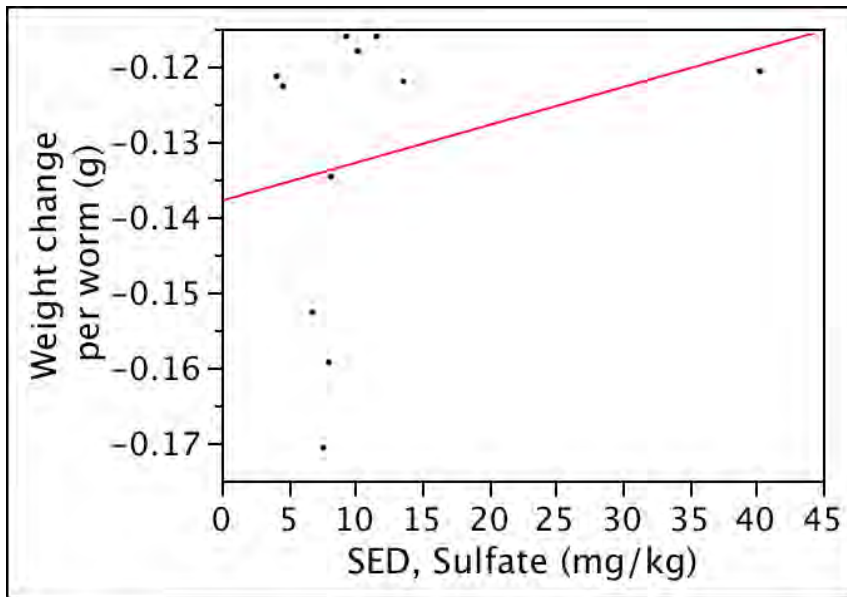

Figure E-1.3-4 Bivariate plot of worm growth versus sulfate (potential confounding factor).
Weight change per worm (g) = -0.138 + 0.000502*SED, sulfate; r2 = 0.0663; n = 11; p = 0.445.

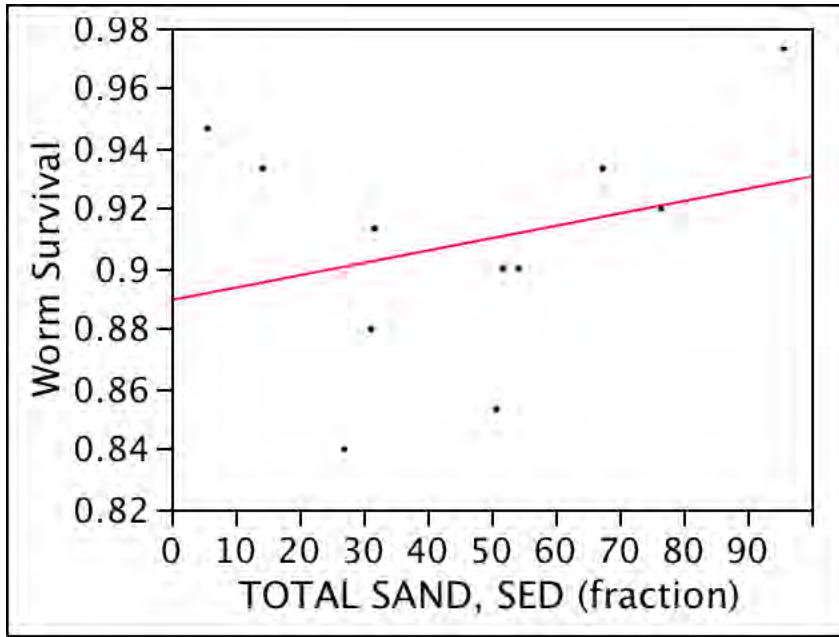

Figure E-1.3-5 Bivariate plot of worm survival versus total sand (potential confounding factor).
Worm survival = $0.890 + 0.000411 \times \text{total sand, SED}$; $r^2 = 0.0780$; $n = 11$; $p = 0.401$.

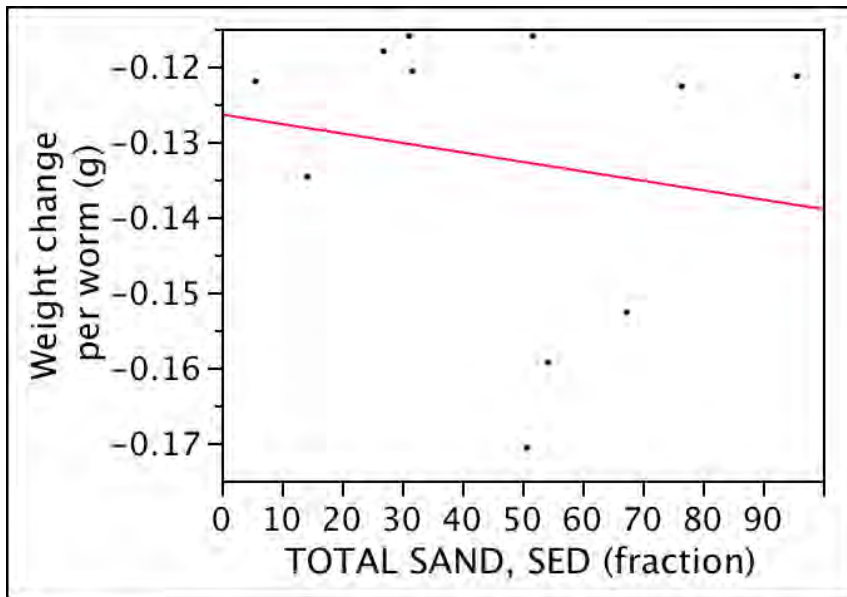

Figure E-1.3-6 Bivariate plot of worm growth versus total sand (potential confounding factor).
Weight change per worm (g) = $-0.126 - 0.000126 \times \text{total sand, SED}$; $r^2 = 0.0307$; $n = 11$; $p = 0.606$.

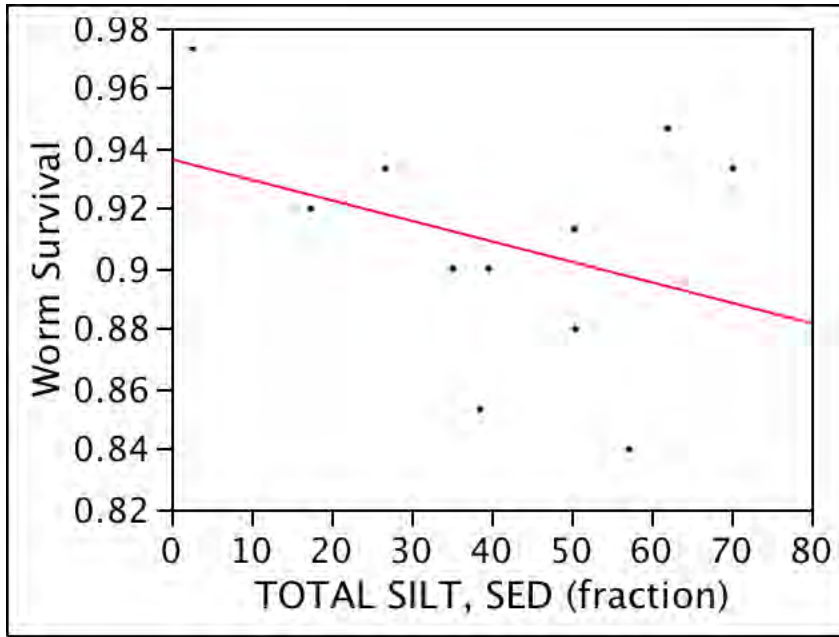

Figure E-1.3-7 Bivariate plot of worm survival versus total silt (potential confounding factor).
 Worm survival = $0.936 - 0.000681 \cdot \text{total silt, SED}$; $r^2 = 0.118$; $n = 11$; $p = 0.301$.

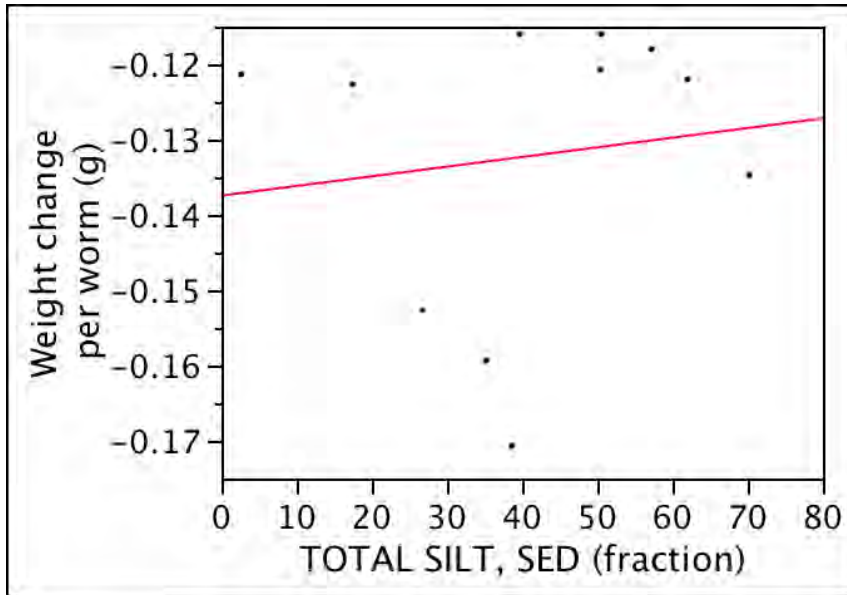

Figure E-1.3-8 Bivariate plot of worm growth versus total silt (potential confounding factor).
 Weight change per worm (g) = $-0.137 + 0.000128 \cdot \text{total silt, SED}$; $r^2 = 0.017$; $n = 11$; $p = 0.700$.

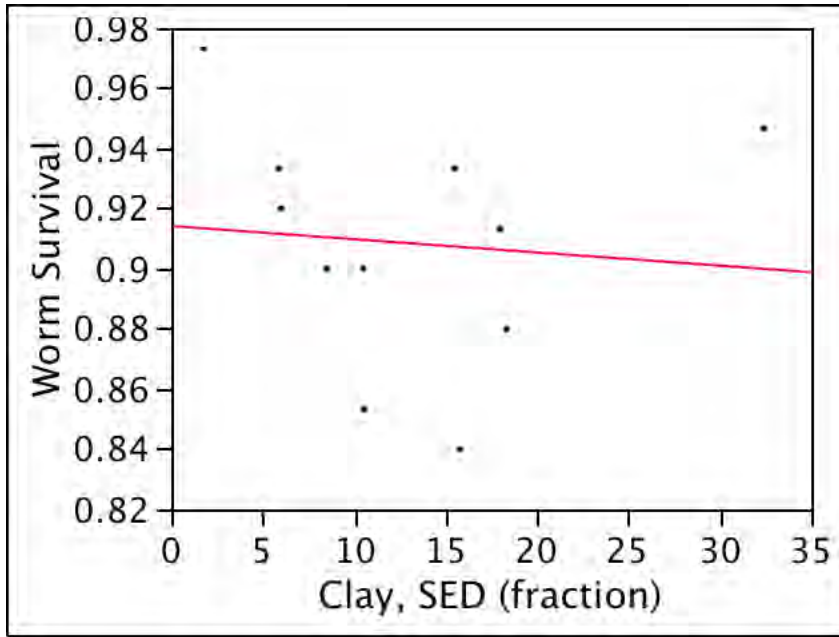

Figure E-1.3-9 Bivariate plot of worm survival versus clay (potential confounding factor). Worm survival = $0.914 - 0.000440 \cdot \text{clay, SED}$; $r^2 = 0.0086$; $n = 11$; $p = 0.786$.

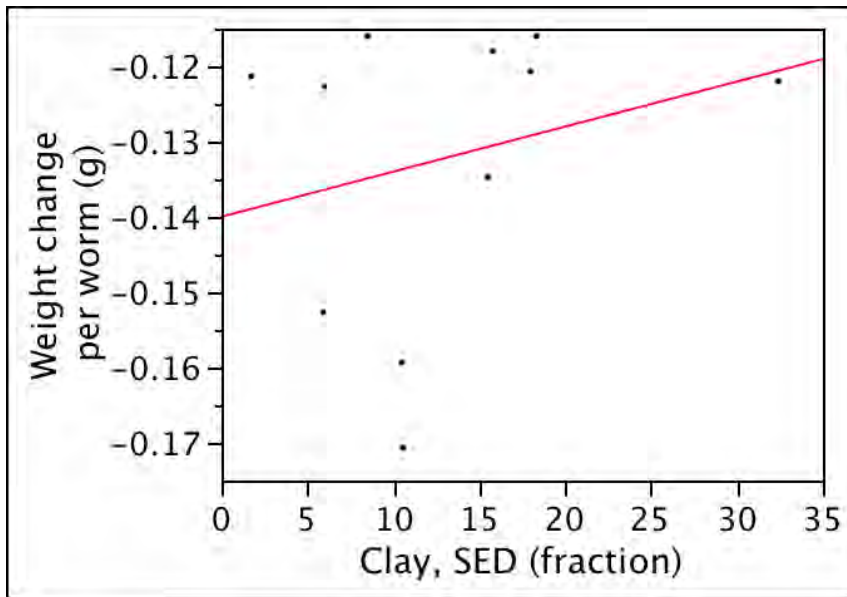

Figure E-1.3-10 Bivariate plot of worm growth versus clay (potential confounding factor). Weight change per worm (g) = $-0.140 + 0.000599 \cdot \text{clay, SED}$; $r^2 = 0.0659$; $n = 11$; $p = 0.446$.

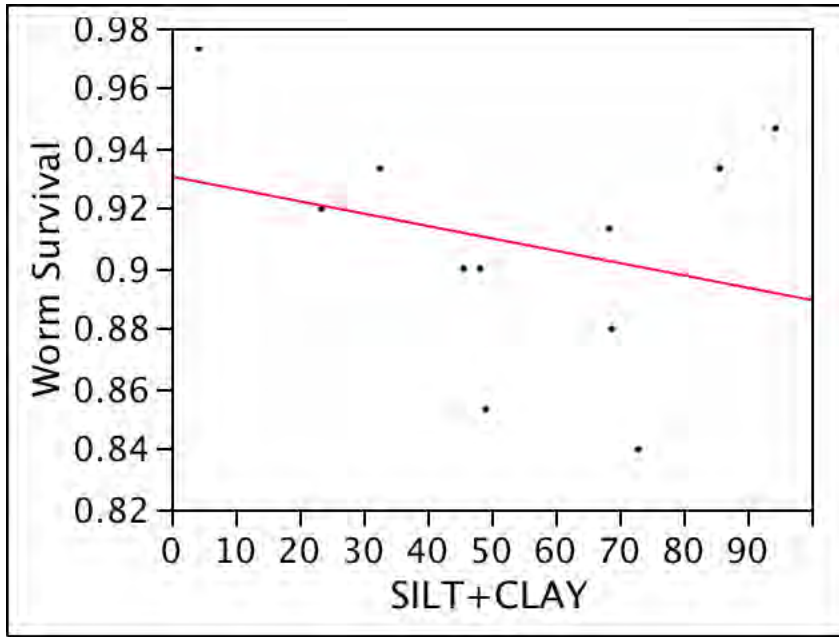

Figure E-1.3-11 Bivariate plot of worm survival versus silt+clay (potential confounding factor).
 Worm survival = $0.931 - 0.000411 \cdot \text{silt+clay}$; $r^2 = 0.079$; $n = 11$; $p = 0.402$.

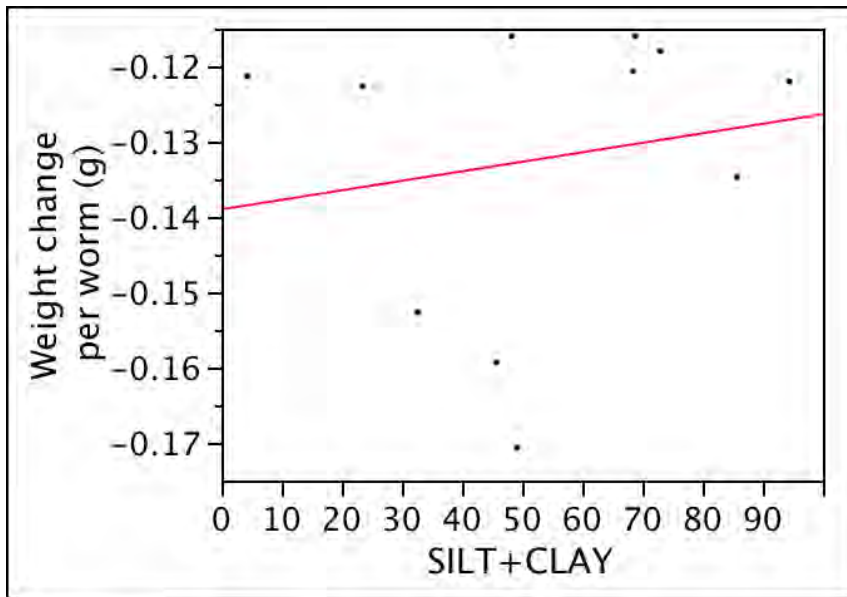

Figure E-1.3-12 Bivariate plot of worm growth versus silt+clay (potential confounding factor).
 Weight change per worm (g) = $-0.139 + 0.000126 \cdot \text{silt+clay}$; $r^2 = 0.0309$; $n = 11$; $p = 0.605$.

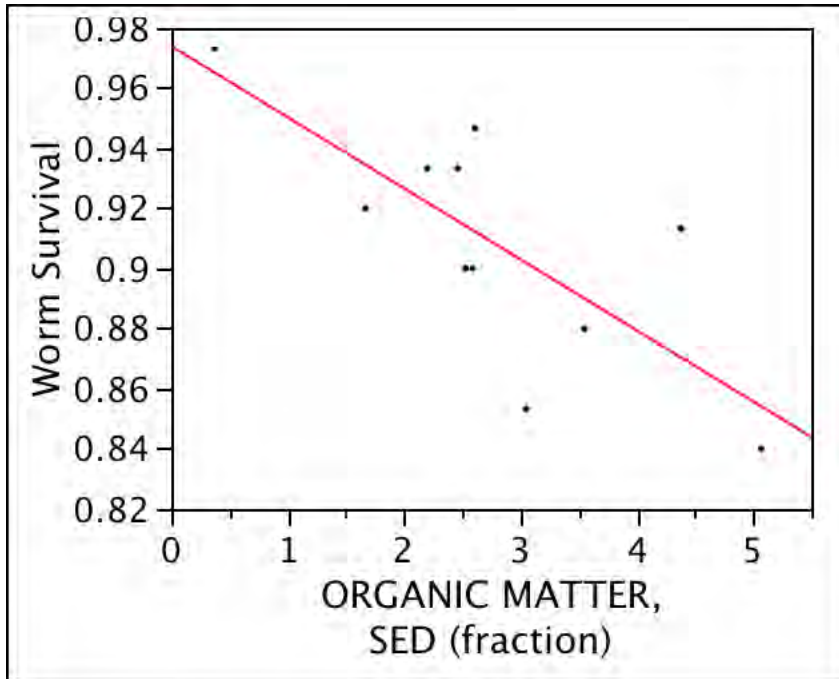

Figure E-1.3-13 Bivariate plot of worm survival versus organic matter (potential confounding factor). Worm survival = $0.974 - 0.0236 \times \text{organic matter, SED}$; $r^2 = 0.571$; $n = 11$; $p = 0.0072$.

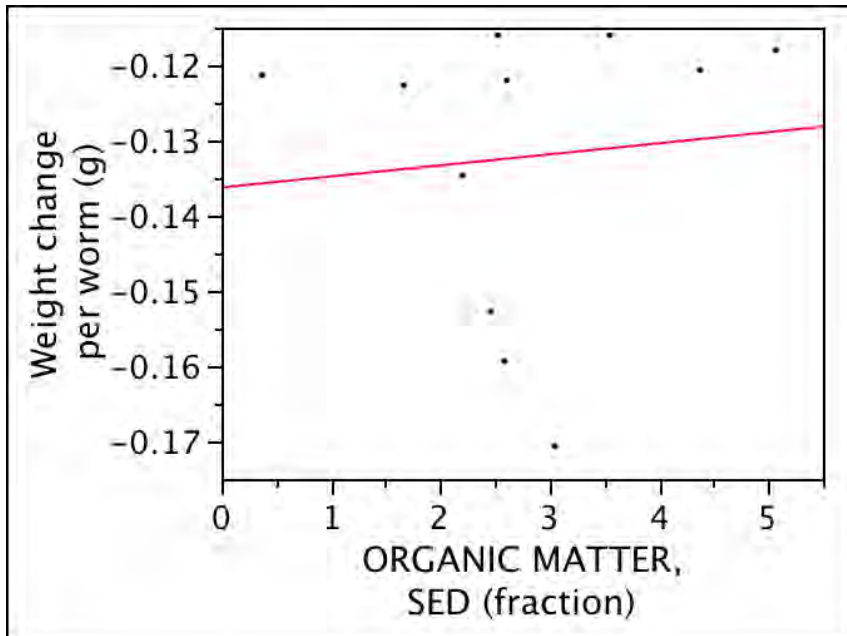

Figure E-1.3-14 Bivariate plot of worm growth versus organic matter (potential confounding factor). Weight change per worm (g) = $-0.136 + 0.00147 \times \text{organic matter, SED}$; $r^2 = 0.0091$; $n = 11$; $p = 0.780$.

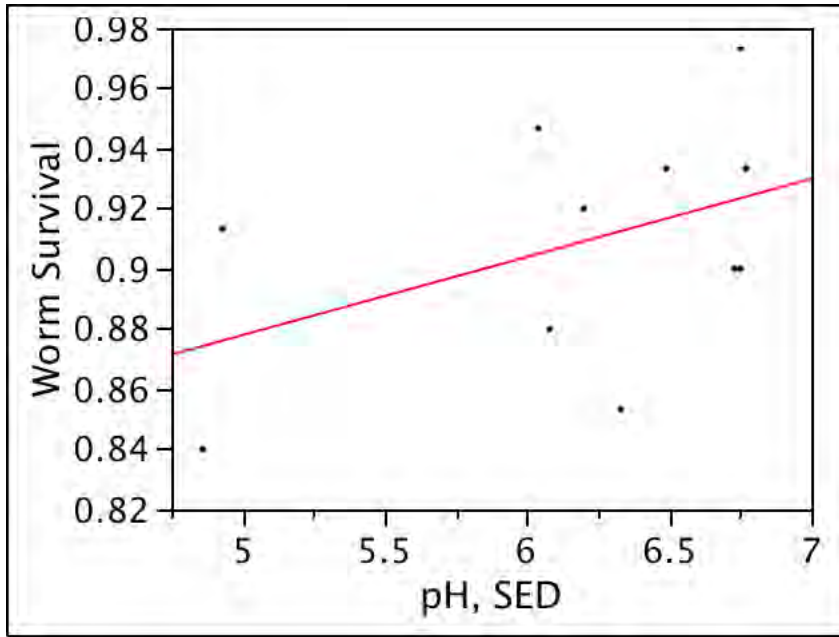

Figure E-1.3-15 Bivariate plot of worm survival versus pH (potential confounding factor). Worm survival = $0.748 + 0.0260 \cdot \text{pH, SED}$; $r^2 = 0.204$; $n = 11$; $p = 0.163$.

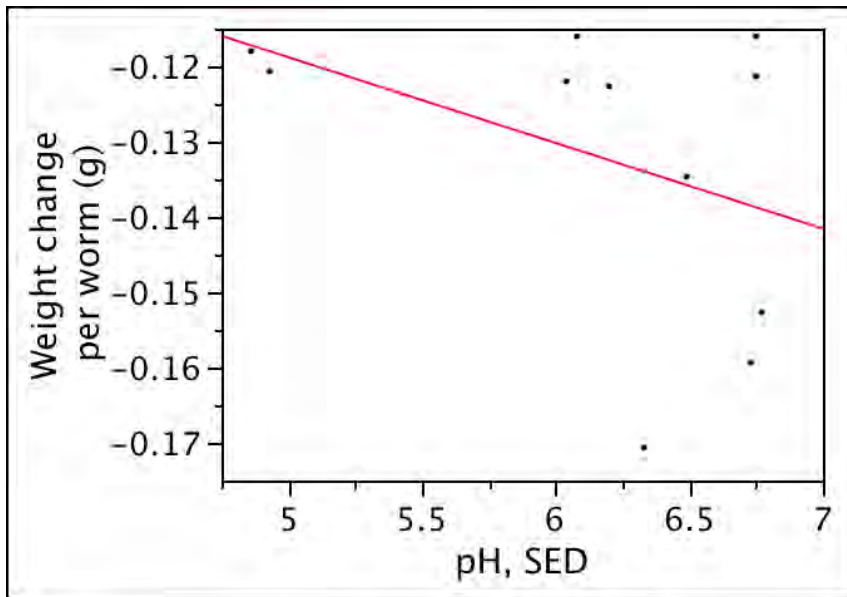

Figure E-1.3-16 Bivariate plot of worm growth versus pH (potential confounding factor). Weight change per worm (g) = $-0.0619 - 0.0114 \cdot \text{pH, SED}$; $r^2 = 0.162$; $n = 11$; $p = 0.220$.

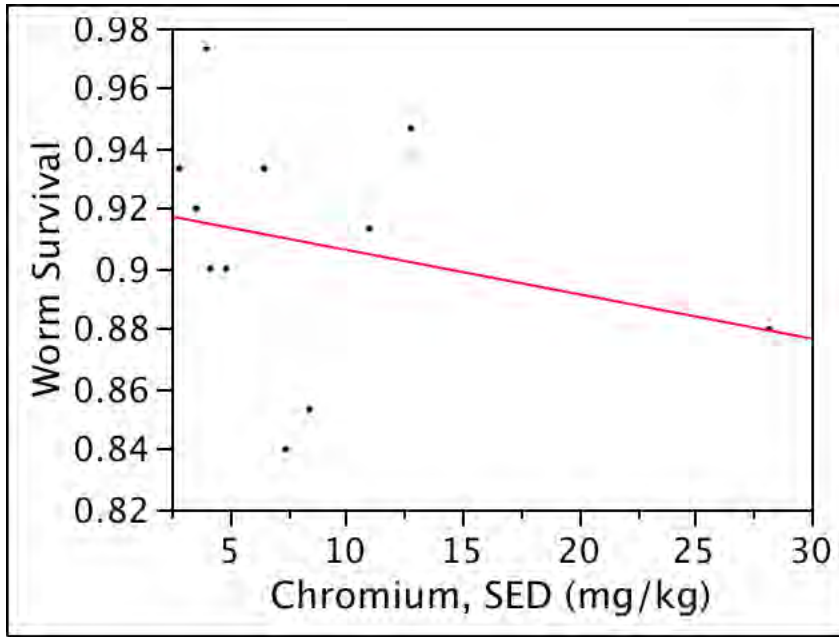

Figure E-1.3-17 Bivariate plot of worm survival versus chromium (COPEC). Worm survival = $0.9210795 - 0.00148 \cdot \text{chromium, SED}$; $r^2 = 0.0730$; $n = 11$; $p = 0.422$.

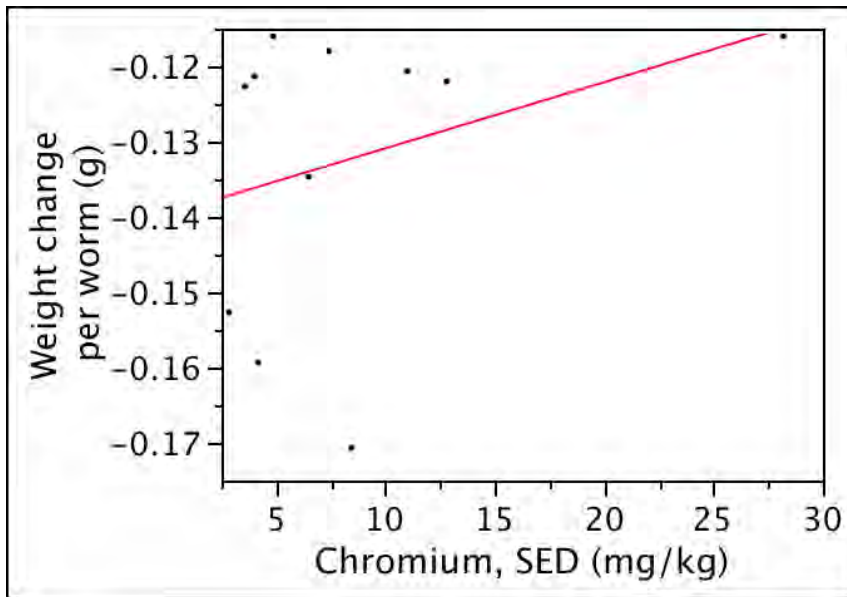

Figure E-1.3-18 Bivariate plot of worm growth versus chromium (COPEC). Weight change per worm (g) = $-0.140 + 0.000878 \cdot \text{chromium, SED}$; $r^2 = 0.106$; $n = 11$; $p = 0.328$.

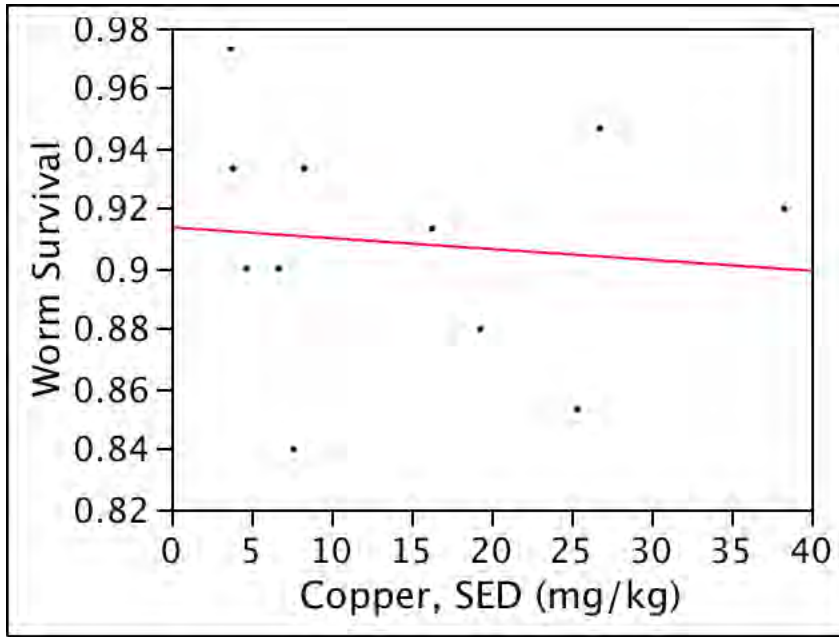

Figure E-1.3-19 Bivariate plot of worm survival versus copper (COPEC). Worm survival = $0.914 - 0.000362 \cdot \text{copper, SED}$; $r^2 = 0.0111$; $n = 11$; $p = 0.758$.

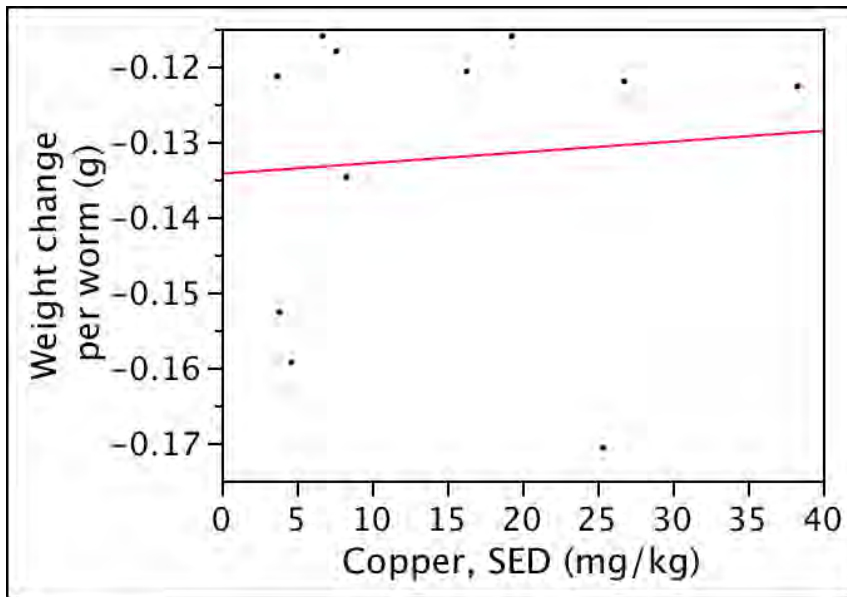

Figure E-1.3-20 Bivariate plot of worm growth versus copper (COPEC). Weight change per worm (g) = $-0.134 + 0.000143 \cdot \text{copper, SED}$; $r^2 = 0.00716$; $n = 11$; $p = 0.805$.

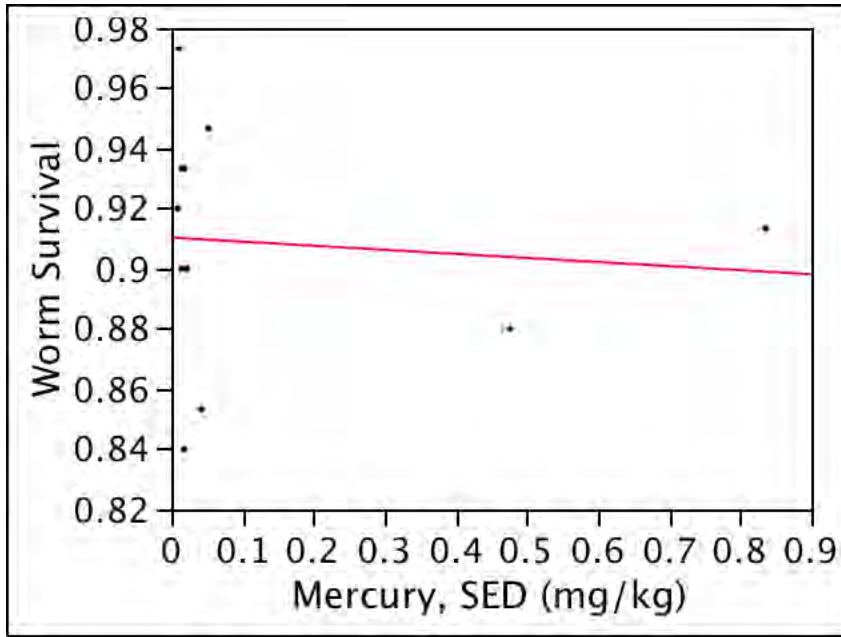

Figure E-1.3-21 Bivariate plot of worm survival versus mercury (COPEC). Worm survival = $0.910 - 0.0136 * mercury, SED$; $r^2 = 0.00845$; $n = 11$; $p = 0.788$.

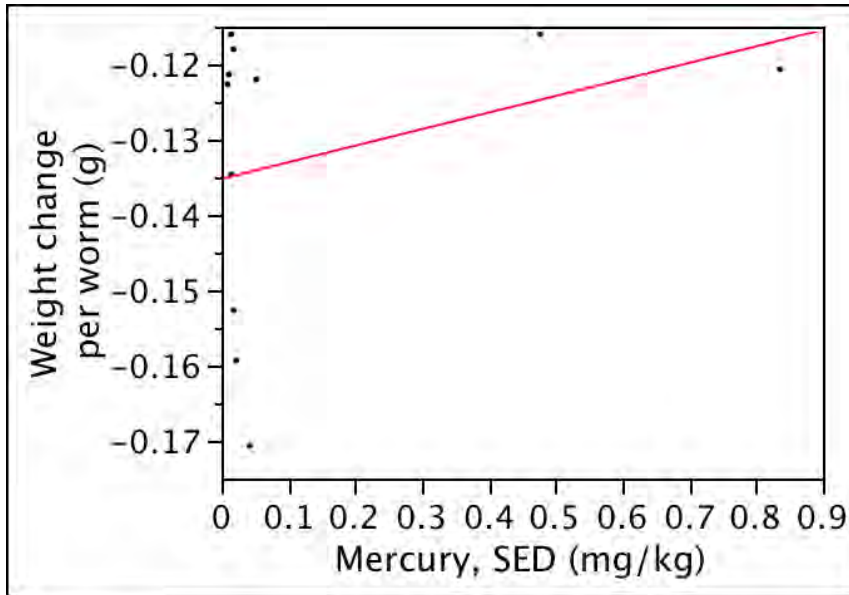

Figure E-1.3-22 Bivariate plot of worm growth versus mercury (COPEC). Weight change per worm (g) = $-0.135 + 0.0220 * mercury, SED$; $r^2 = 0.0919$; $n = 11$; $p = 0.365$.

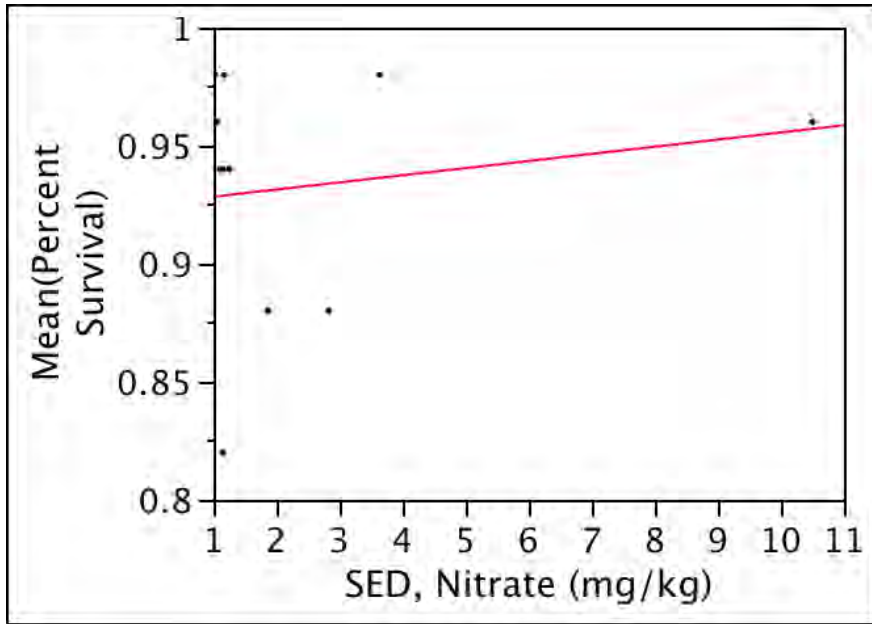

Figure E-1.4-1 Bivariate plot of plant survival in toxicity test versus nitrate in soil sample used in test: $r^2 = 0.027$; $n = 11$; $p = 0.629$

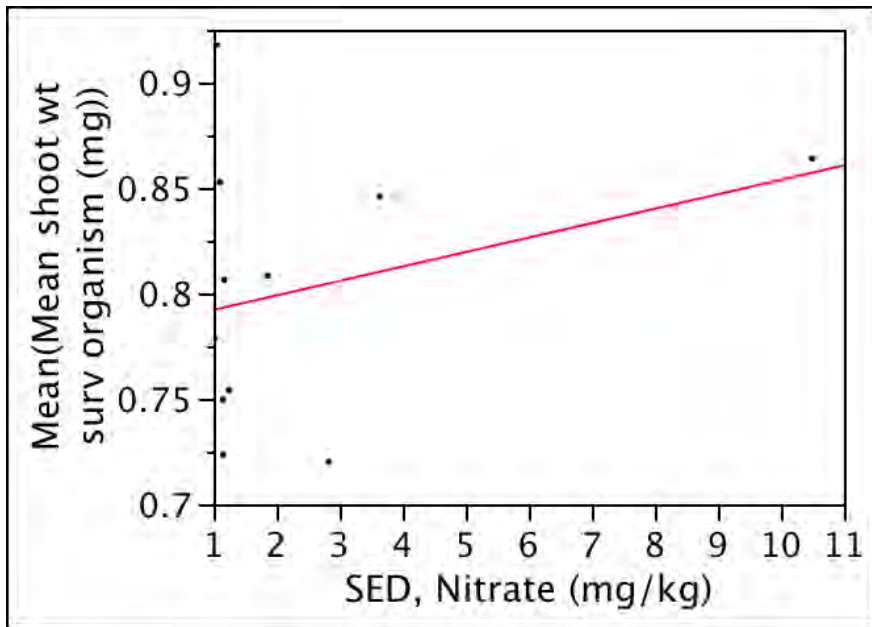

Figure E-1.4-2 Bivariate plot of plant mean shoot weight in toxicity test versus nitrate in soil sample used in test: $r^2 = 0.092$; $n = 11$; $p = 0.365$

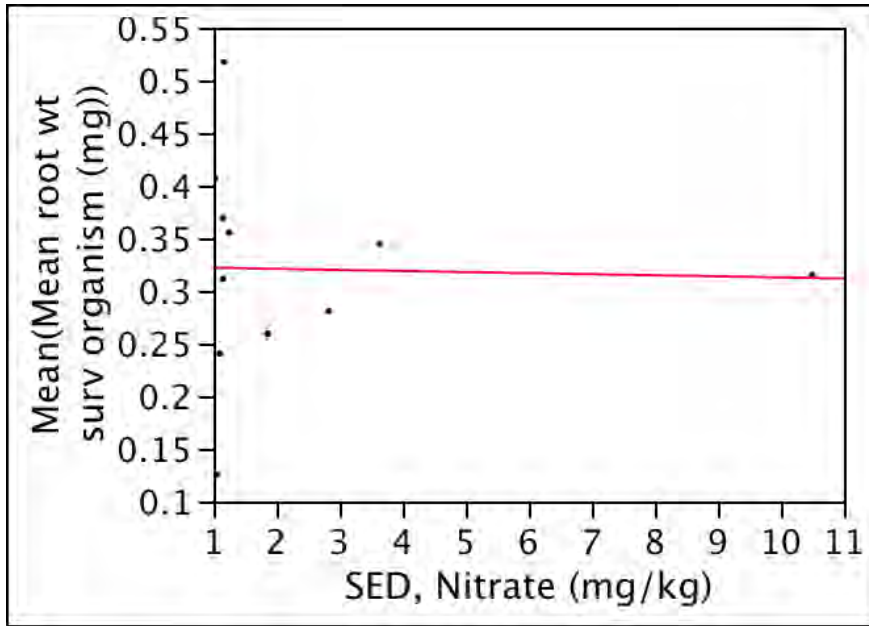

Figure E-1.4-3 Bivariate plot of plant mean root weight in toxicity test versus nitrate in soil sample used in test: $r^2 = 0.0008$; $n = 11$; $p = 0.933$

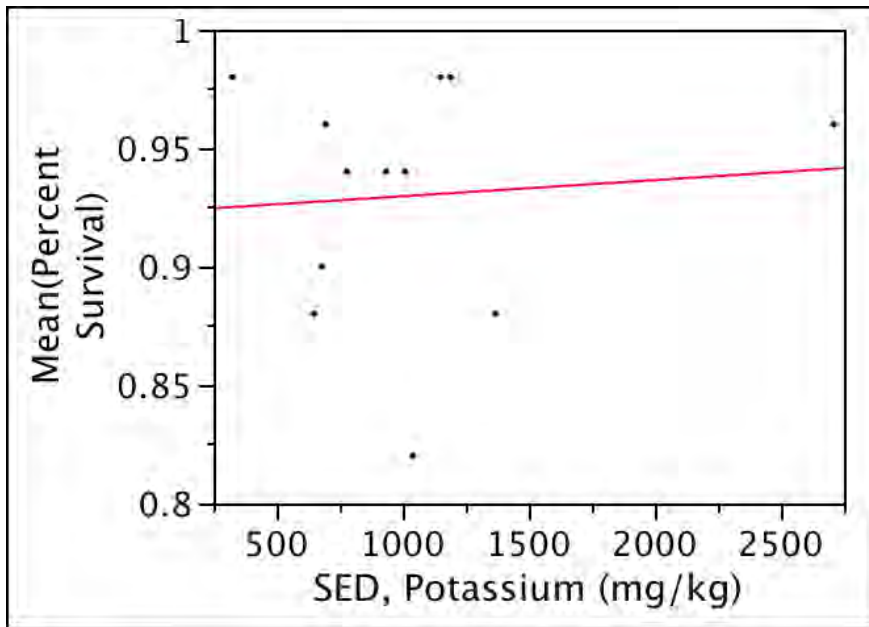

Figure E-1.4-4 Bivariate plot of plant survival in toxicity test versus potassium in soil sample used in test: $r^2 = 0.0066$; $n = 12$; $p = 0.802$

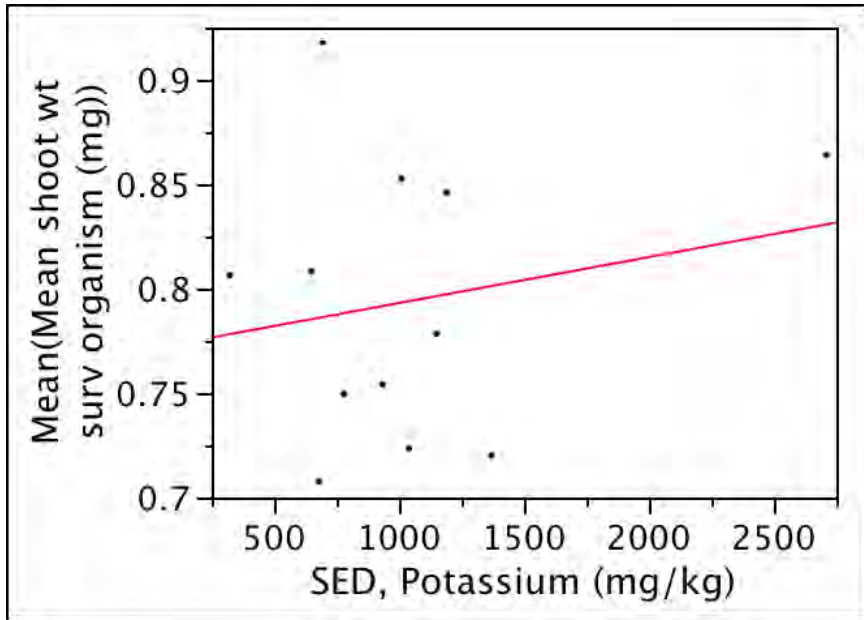

Figure E-1.4-5 Bivariate plot of plant mean shoot weight in toxicity test versus potassium in soil sample used in test: $r^2 = 0.039$; $n = 12$; $p = 0.537$

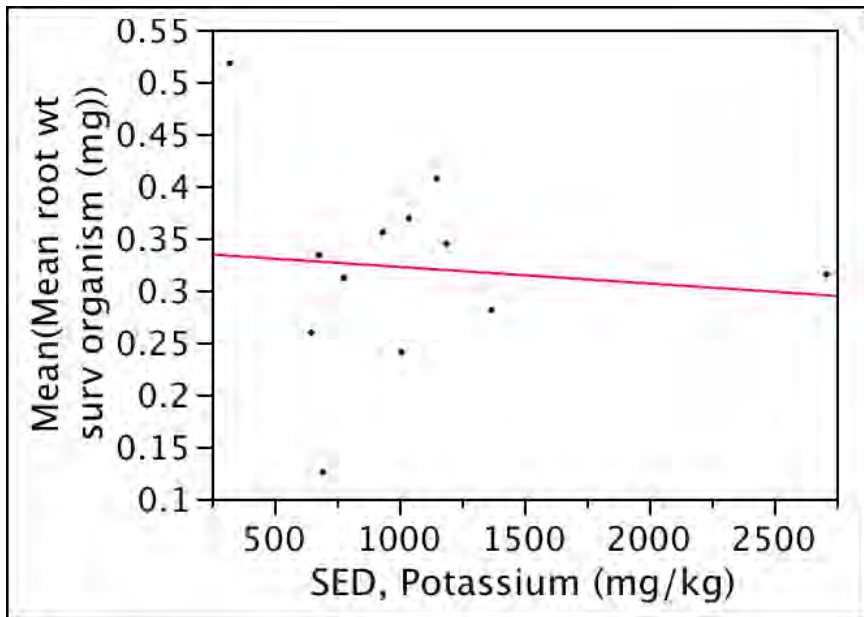

Figure E-1.4-6 Bivariate plot of plant mean root weight in toxicity test versus potassium in soil sample used in test: $r^2 = 0.0099$; $n = 12$; $p = 0.759$

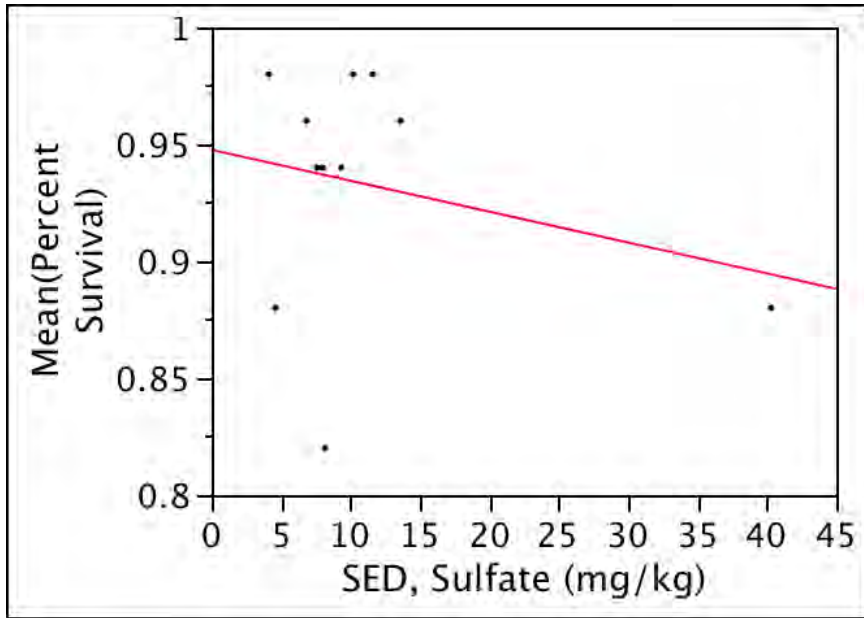

Figure E-1.4-7 Bivariate plot of plant survival in toxicity test versus sulfate in soil sample used in test: $r^2 = 0.066$; $n = 11$; $p = 0.446$

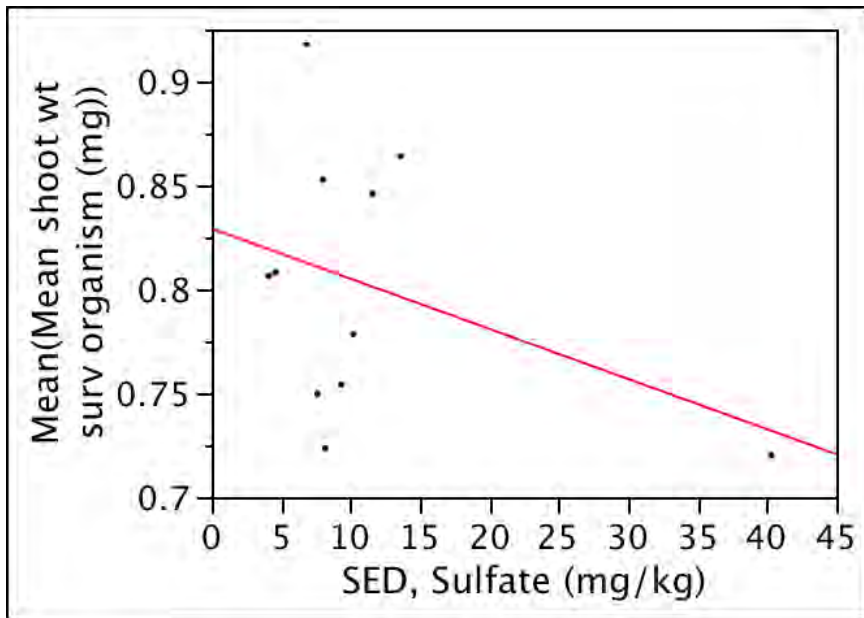

Figure E-1.4-8 Bivariate plot of plant mean shoot weight in toxicity test versus sulfate in soil sample used in test: $r^2 = 0.145$; $n = 11$; $p = 0.248$

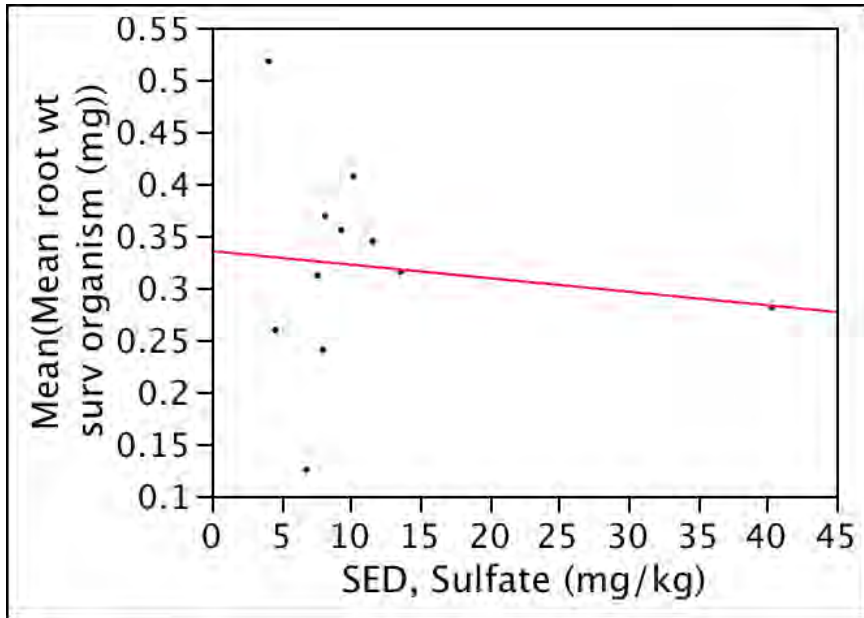

Figure E-1.4-9 Bivariate plot of plant mean root weight in toxicity test versus sulfate in soil sample used in test: $r^2 = 0.017$; $n = 11$; $p = 0.703$

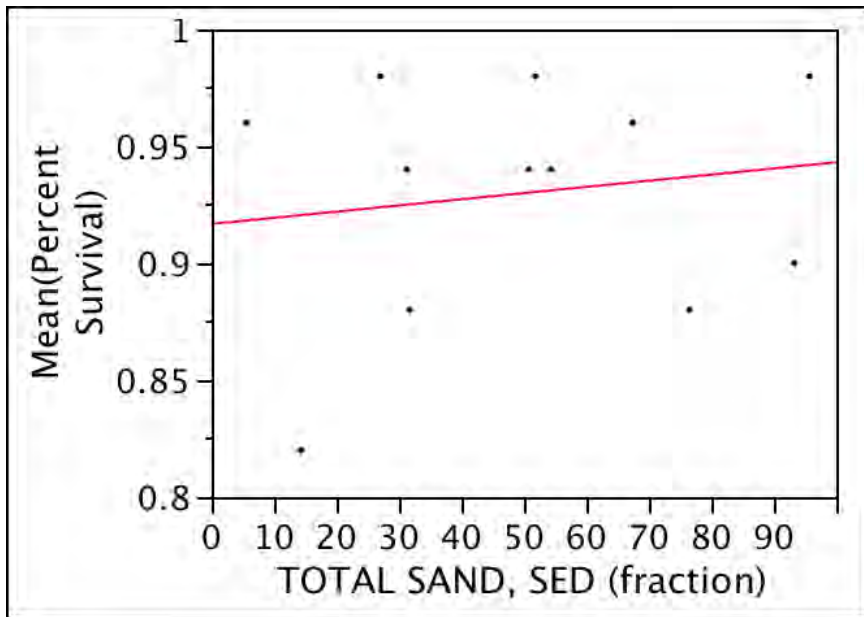

Figure E-1.4-10 Bivariate plot of plant survival in toxicity test versus fraction sand-sized particles in soil sample used in test: $r^2 = 0.024$; $n = 12$; $p = 0.632$

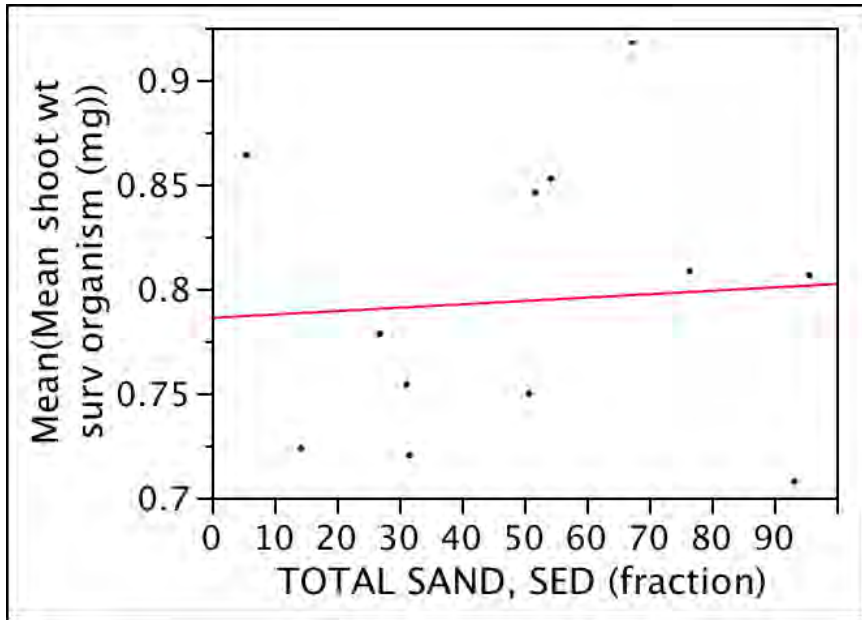

Figure E-1.4-11 Bivariate plot of plant mean shoot weight in toxicity test versus fraction sand-sized particles in soil sample used in test: $r^2 = 0.005$; $n = 12$; $p = 0.825$

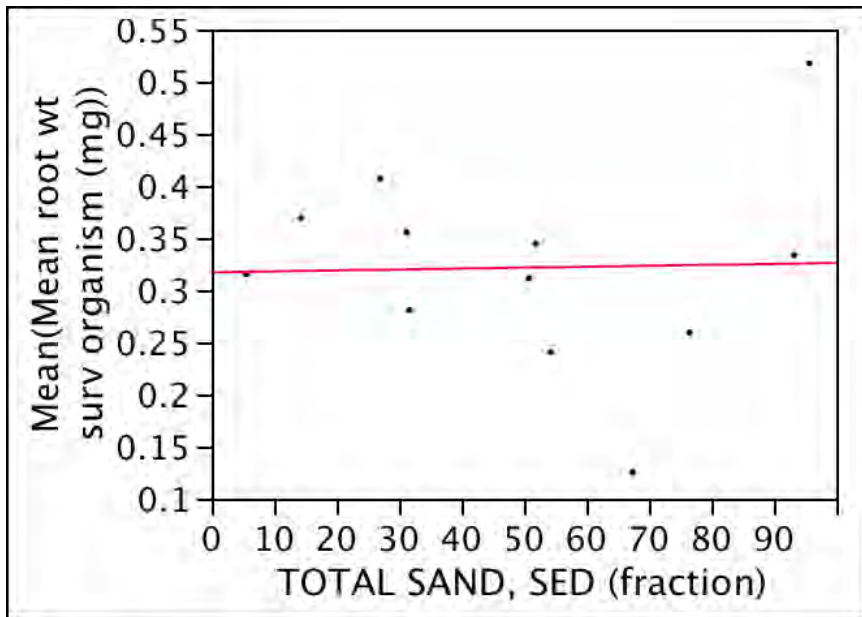

Figure E-1.4-12 Bivariate plot of plant mean root weight in toxicity test versus fraction sand-sized particles in soil sample used in test: $r^2 = 0.0008$; $n = 12$; $p = 0.932$

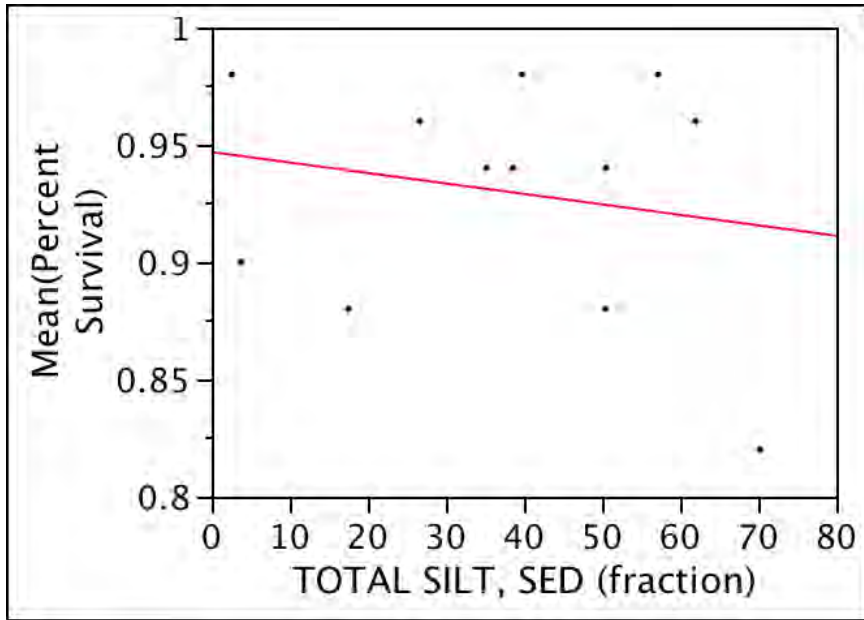

Figure E-1.4-13 Bivariate plot of plant survival in toxicity test versus fraction silt-sized particles in soil sample used in test: $r^2 = 0.038$; $n = 12$; $p = 0.544$

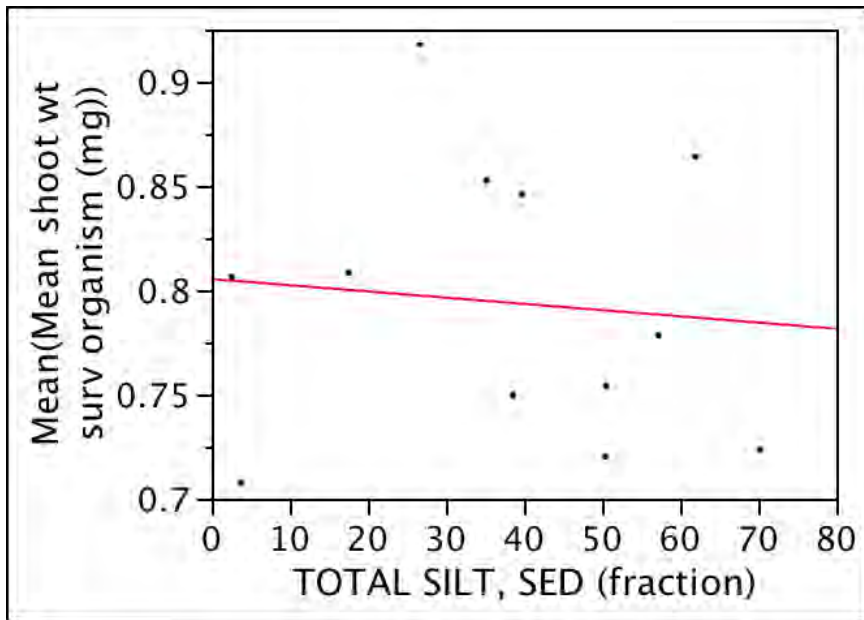

Figure E-1.4-14 Bivariate plot of plant mean shoot weight in toxicity test versus fraction silt-sized particles in soil sample used in test: $r^2 = 0.010$; $n = 12$; $p = 0.760$

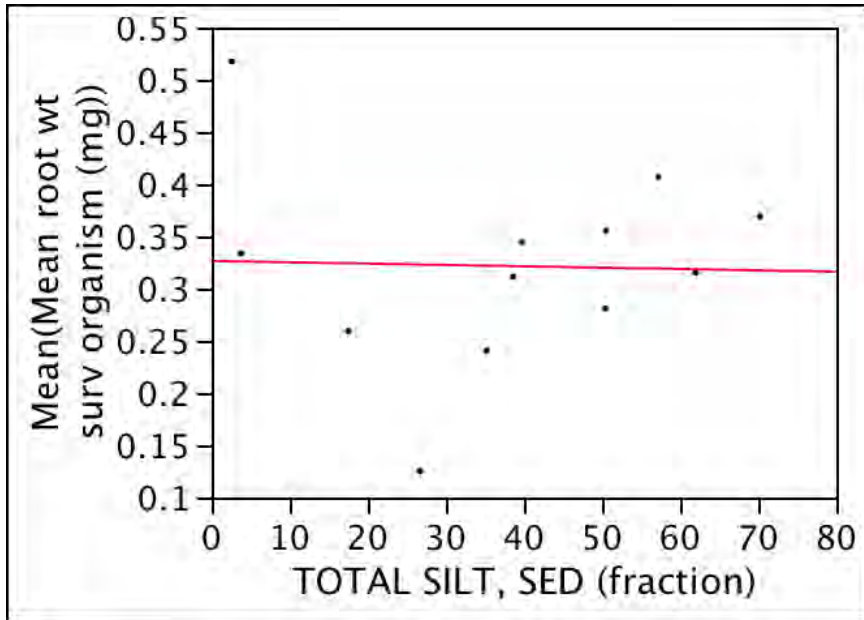

Figure E-1.4-15 Bivariate plot of plant mean root weight in toxicity test versus fraction silt-sized particles in soil sample used in test: $r^2 = 0.0008$; $n = 12$; $p = 0.928$

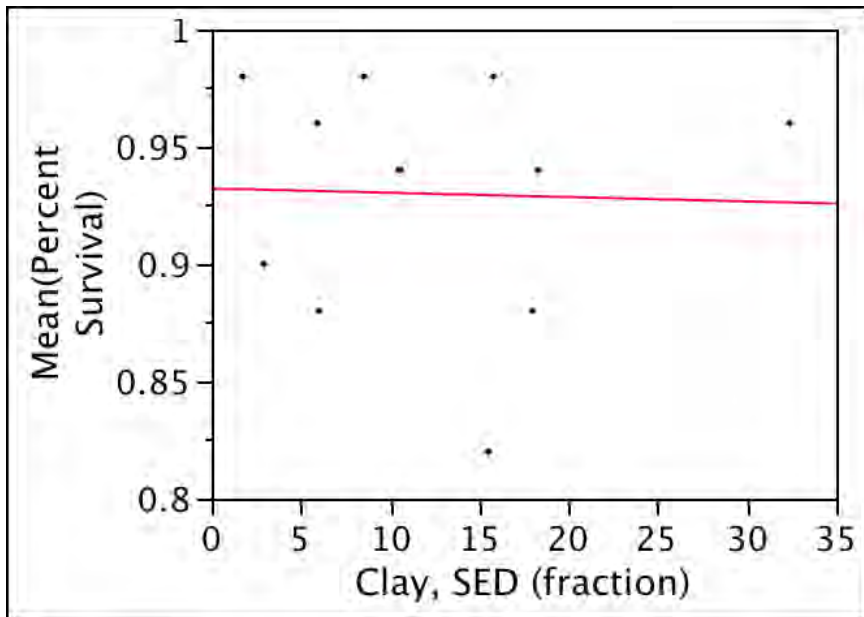

Figure E-1.4-16 Bivariate plot of plant survival in toxicity test versus fraction clay-sized particles in soil sample used in test: $r^2 = 0.001$; $n = 12$; $p = 0.923$

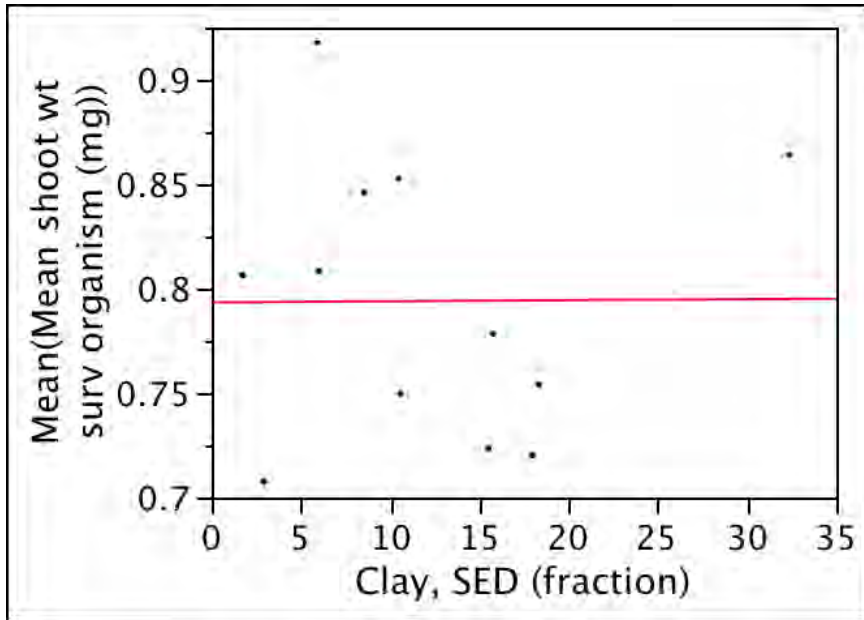

Figure E-1.4-17 Bivariate plot of plant mean shoot weight in toxicity test versus fraction clay-sized particles in soil sample used in test: $r^2 < 0.0001$; $n = 12$; $p = 0.984$

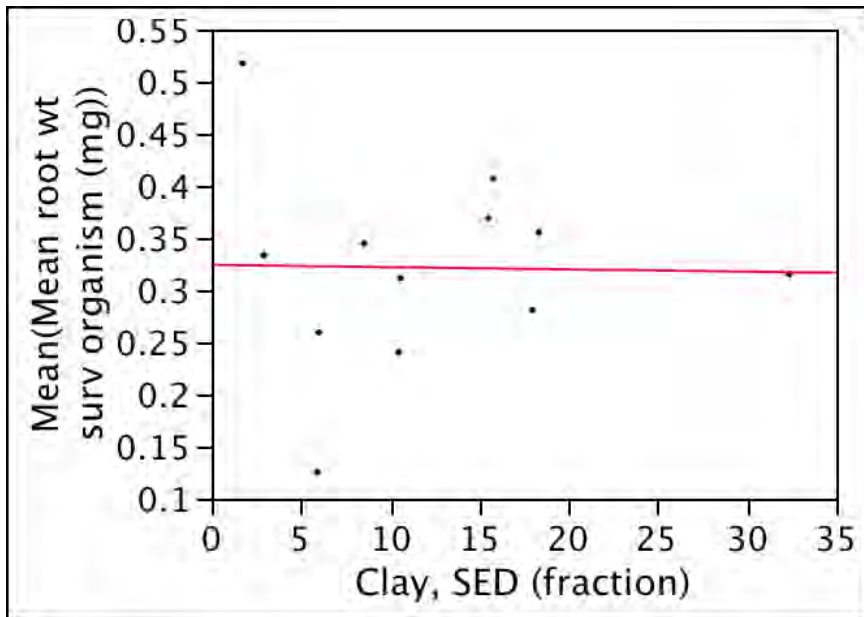

Figure E-1.4-18 Bivariate plot of plant mean root weight in toxicity test versus fraction clay-sized particles in soil sample used in test: $r^2 = 0.0004$; $n = 12$; $p = 0.953$

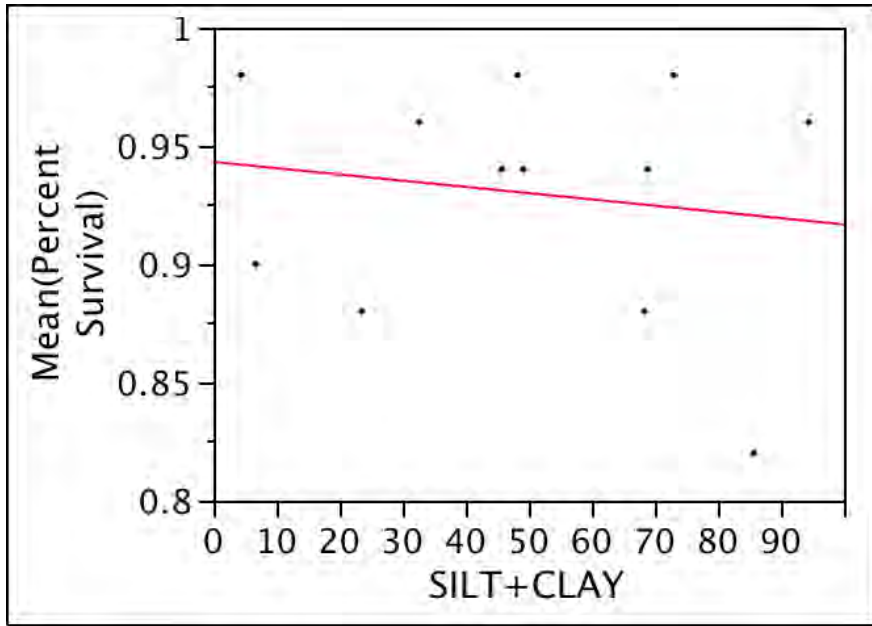

Figure E-1.4-19 Bivariate plot of plant survival in toxicity test versus fraction silt+clay-sized particles in soil sample used in test: $r^2 = 0.024$; $n = 12$; $p = 0.631$

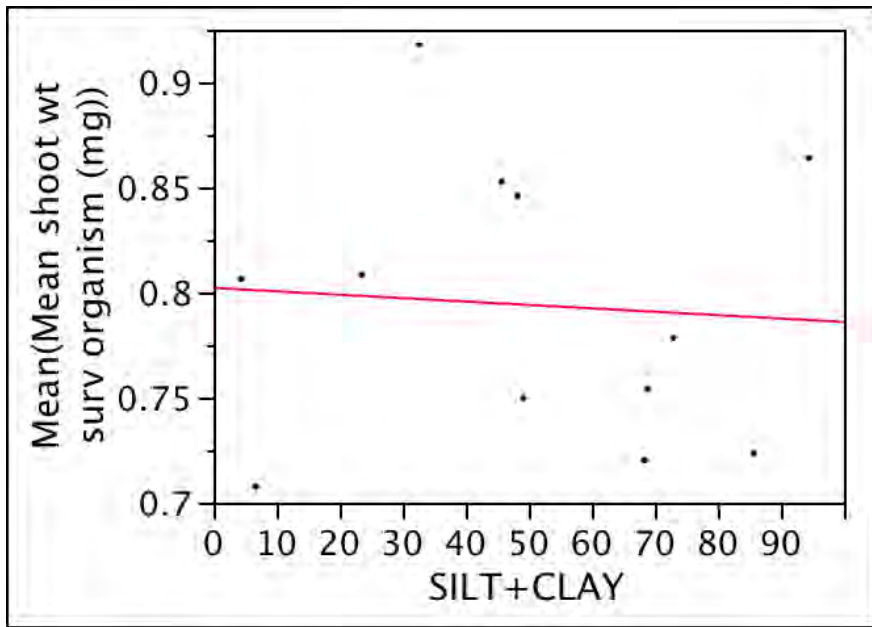

Figure E-1.4-20 Bivariate plot of plant mean shoot weight in toxicity test versus fraction silt+clay-sized particles in soil sample used in test: $r^2 = 0.0051$; $n = 12$; $p = 0.825$

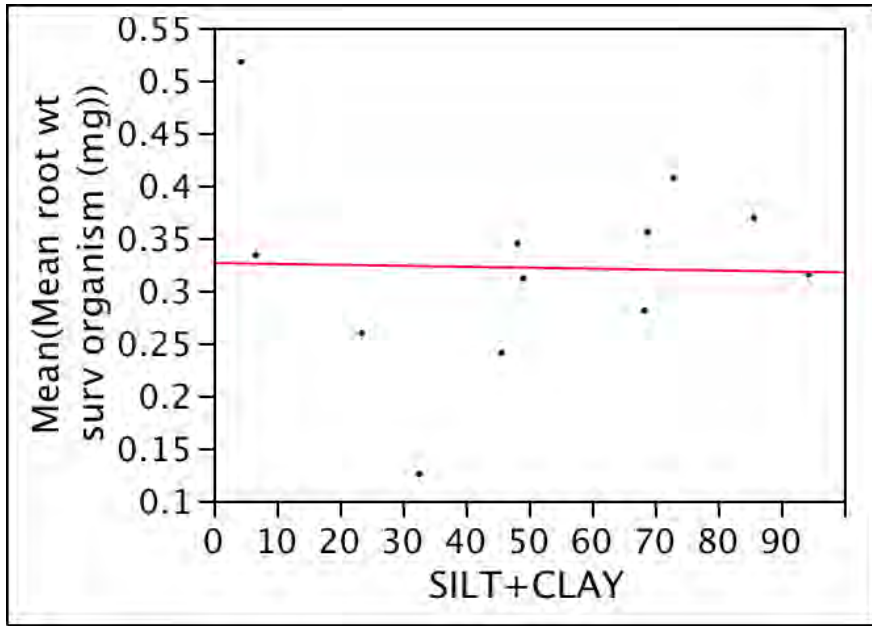

Figure E-1.4-21 Bivariate plot of plant mean root weight in toxicity test versus fraction silt+clay-sized particles in soil sample used in test: $r^2 = 0.0008$; $n = 12$; $p = 0.932$

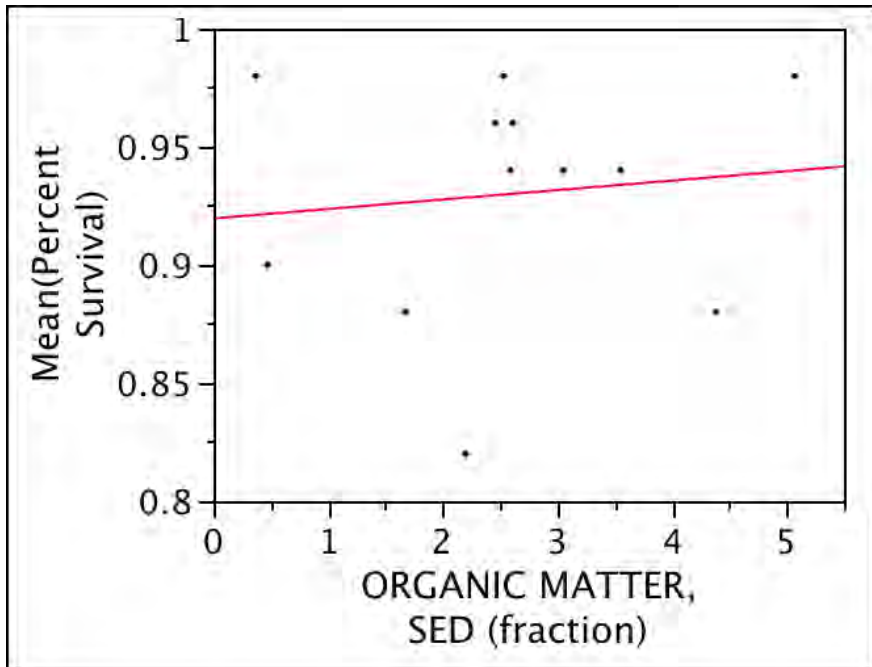

Figure E-1.4-22 Bivariate plot of plant survival in toxicity test versus organic matter content in soil sample used in test: $r^2 = 0.012$; $n = 12$; $p = 0.733$

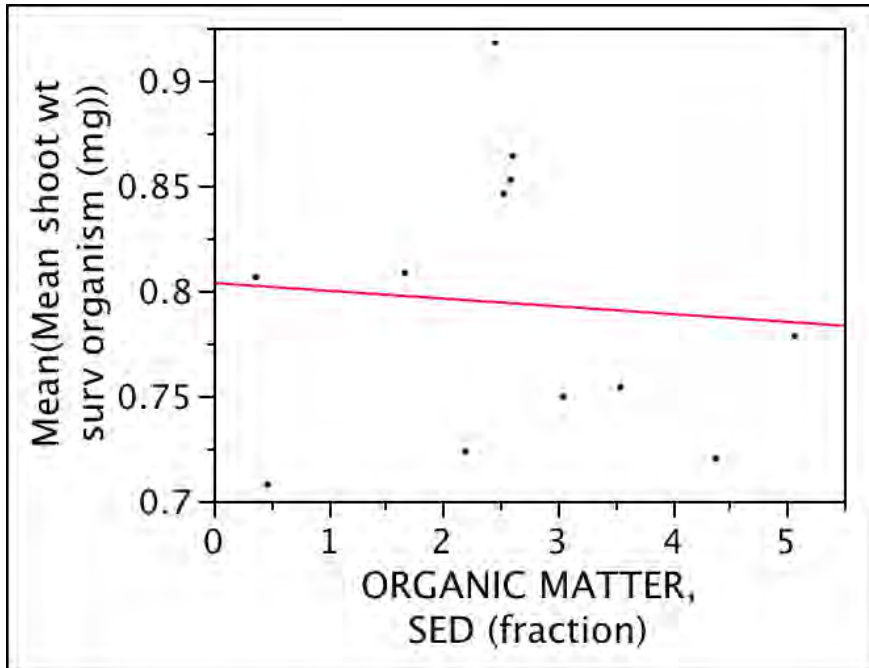

Figure E-1.4-23 Bivariate plot of plant mean shoot weight in toxicity test versus organic matter content in soil sample used in test: $r^2 = 0.006$; $n = 12$; $p = 0.813$

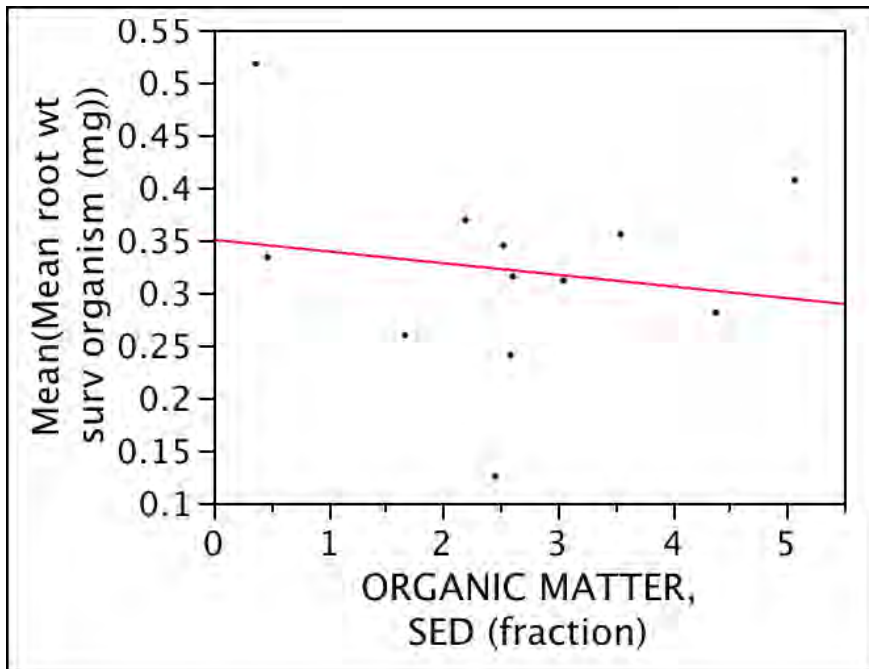

Figure E-1.4-24 Bivariate plot of plant mean root weight in toxicity test versus organic matter content in soil sample used in test: $r^2 = 0.026$; $n = 12$; $p = 0.619$

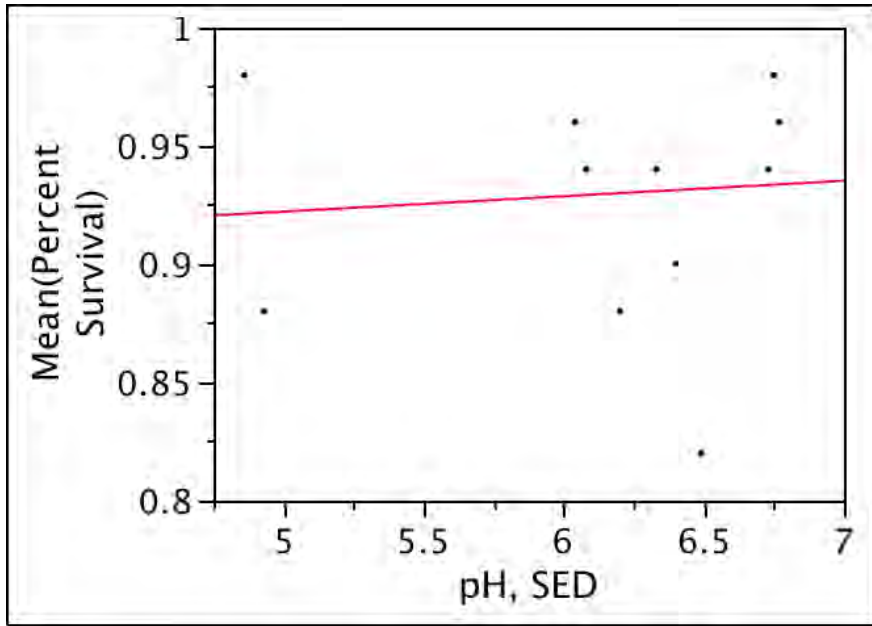

Figure E-1.4-25 Bivariate plot of plant survival in toxicity test versus pH in soil sample used in test: $r^2 = 0.007$; $n = 12$; $p = 0.790$

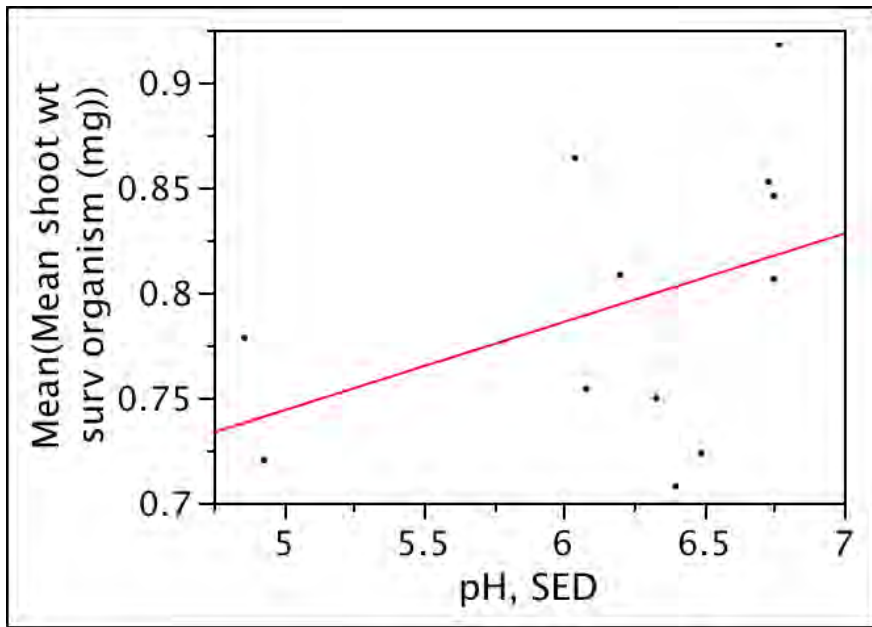

Figure E-1.4-26 Bivariate plot of plant mean shoot weight in toxicity test versus pH in soil sample used in test: $r^2 = 0.175$; $n = 12$; $p = 0.176$

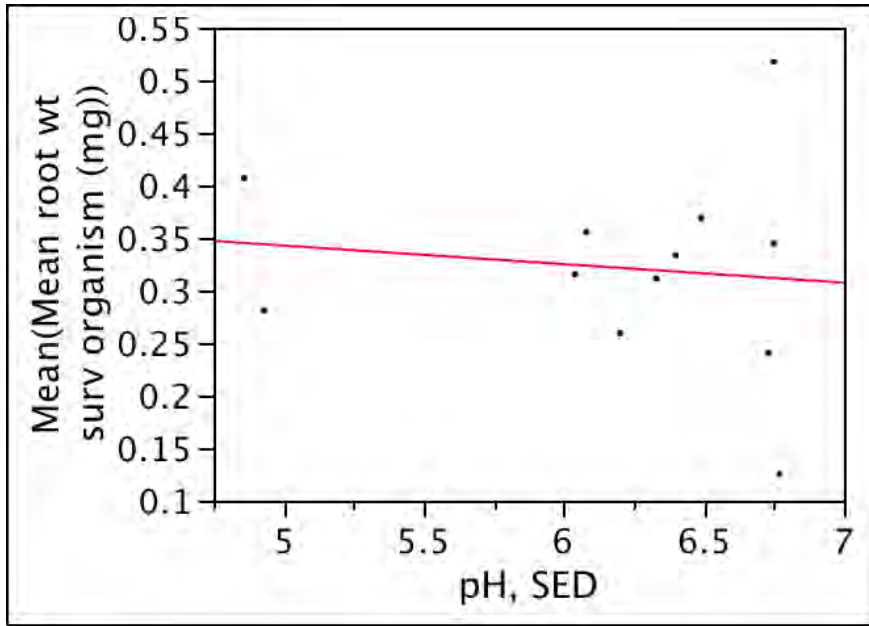

Figure E-1.4-27 Bivariate plot of plant mean root weight in toxicity test versus pH in soil sample used in test: $r^2 = 0.015$; $n = 12$; $p = 0.705$

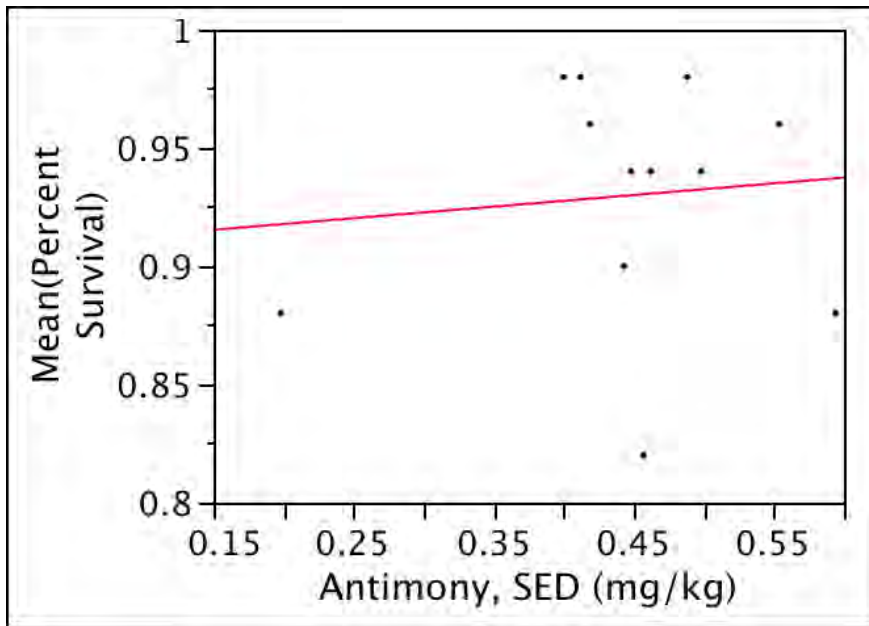

Figure E-1.4-28 Bivariate plot of plant survival in toxicity test versus antimony (COPEC) concentrations in soil sample used in test: $r^2 = 0.009$; $n = 12$; $p = 0.768$

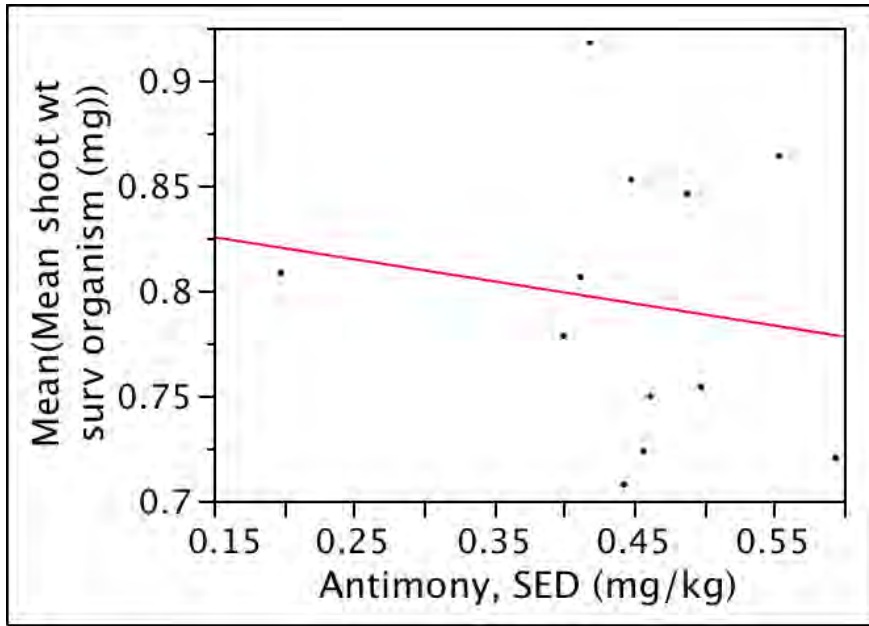

Figure E-1.4-29 Bivariate plot of plant mean shoot weight in toxicity test versus antimony (COPEC) concentrations in soil sample used in test: $r^2 = 0.024$; $n = 12$; $p = 0.633$

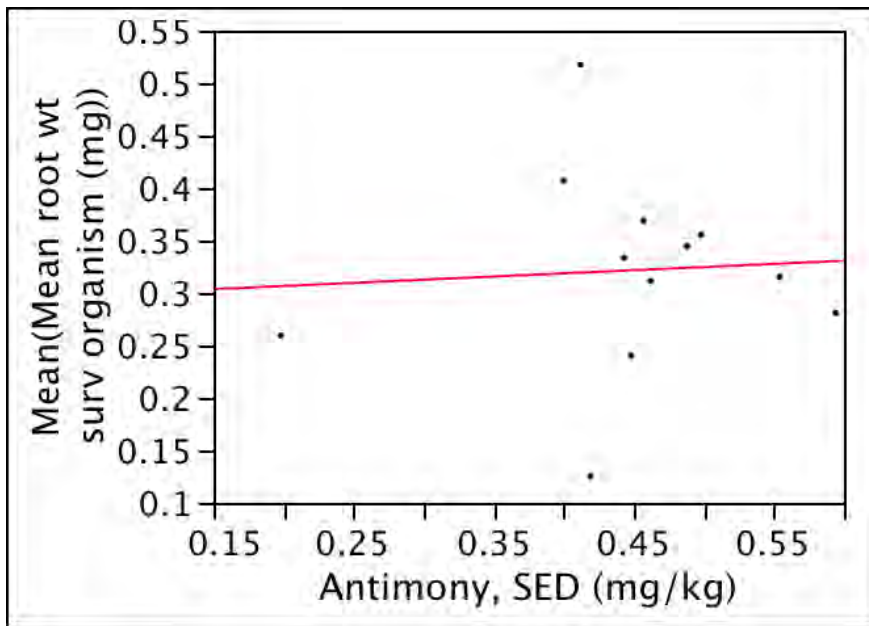

Figure E-1.4-30 Bivariate plot of plant mean root weight in toxicity test versus antimony (COPEC) concentrations in soil sample used in test: $r^2 = 0.004$; $n = 12$; $p = 0.850$

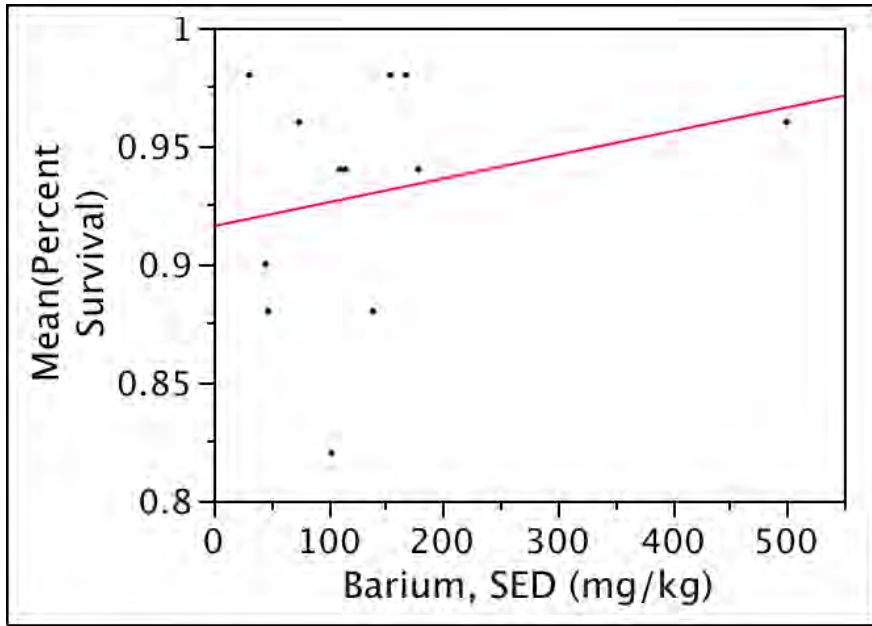

Figure E-1.4-31 Bivariate plot of plant survival in toxicity test versus barium (COPEC) concentrations in soil sample used in test: $r^2 = 0.062$; $n = 12$; $p = 0.437$

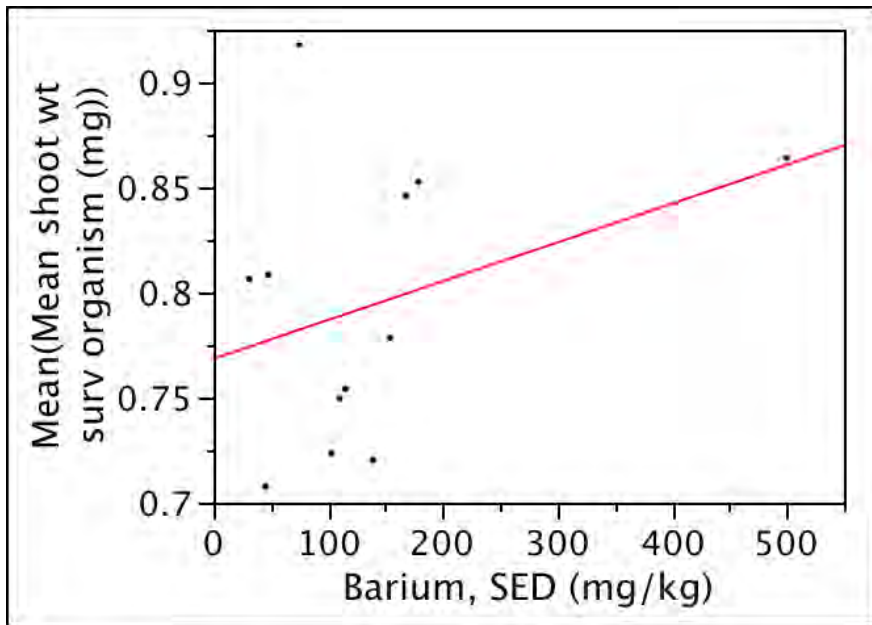

Figure E-1.4-32 Bivariate plot of plant mean shoot weight in toxicity test versus barium (COPEC) concentrations in soil sample used in test: $r^2 = 0.119$; $n = 12$; $p = 0.273$

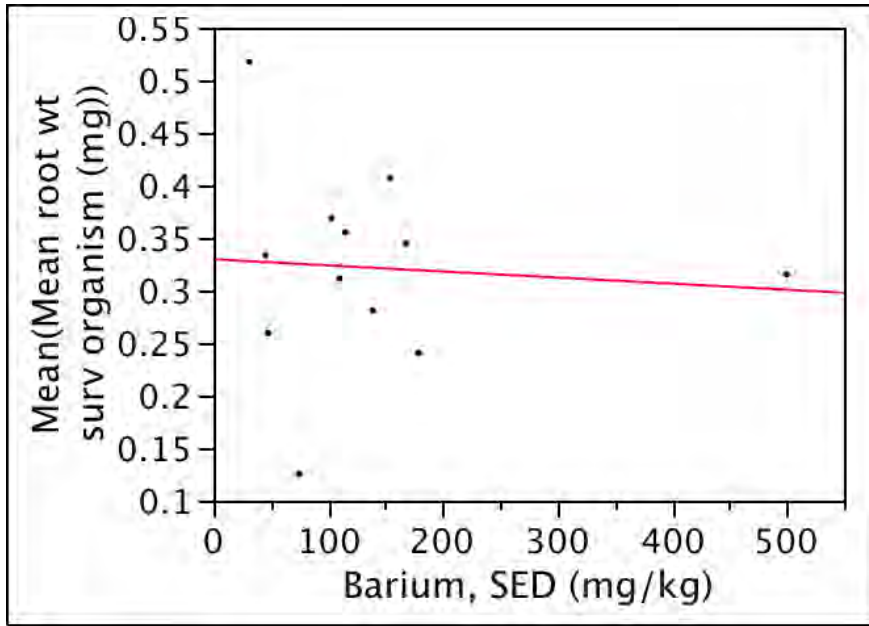

Figure E-1.4-33 Bivariate plot of plant mean root weight in toxicity test versus barium (COPEC) concentrations in soil sample used in test: $r^2 = 0.006$; $n = 12$; $p = 0.817$

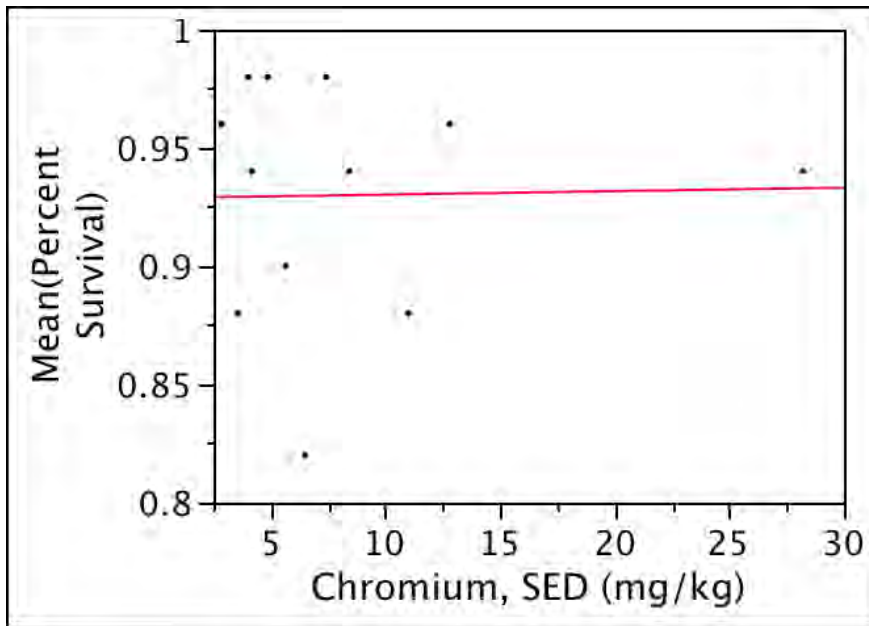

Figure E-1.4-34 Bivariate plot of plant survival in toxicity test versus chromium (COPEC) concentrations in soil sample used in test: $r^2 = 0.0004$; $n = 12$; $p = 0.949$

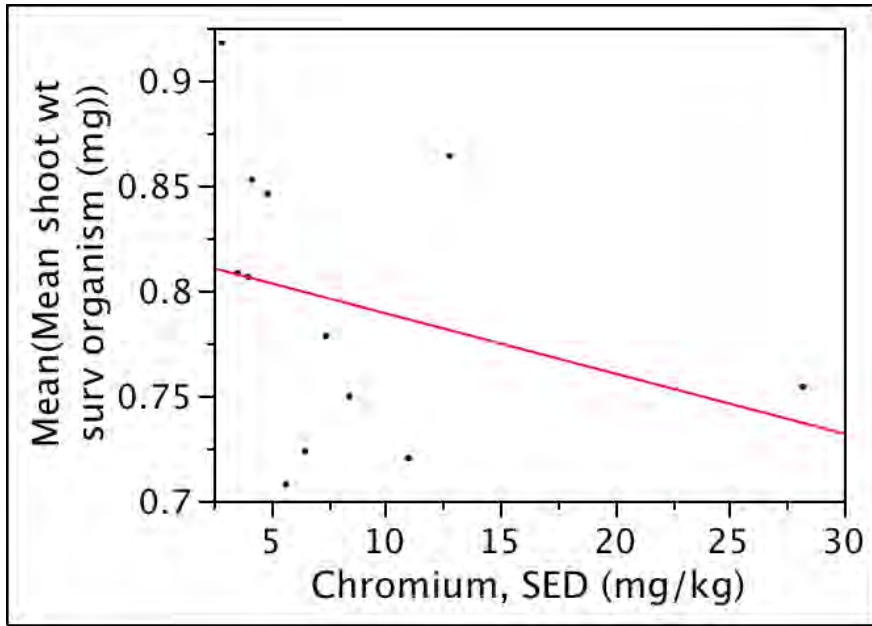

Figure E-1.4-35 Bivariate plot of plant mean shoot weight in toxicity test versus chromium (COPEC) concentrations in soil sample used in test: $r^2 = 0.091$; $n = 12$; $p = 0.342$

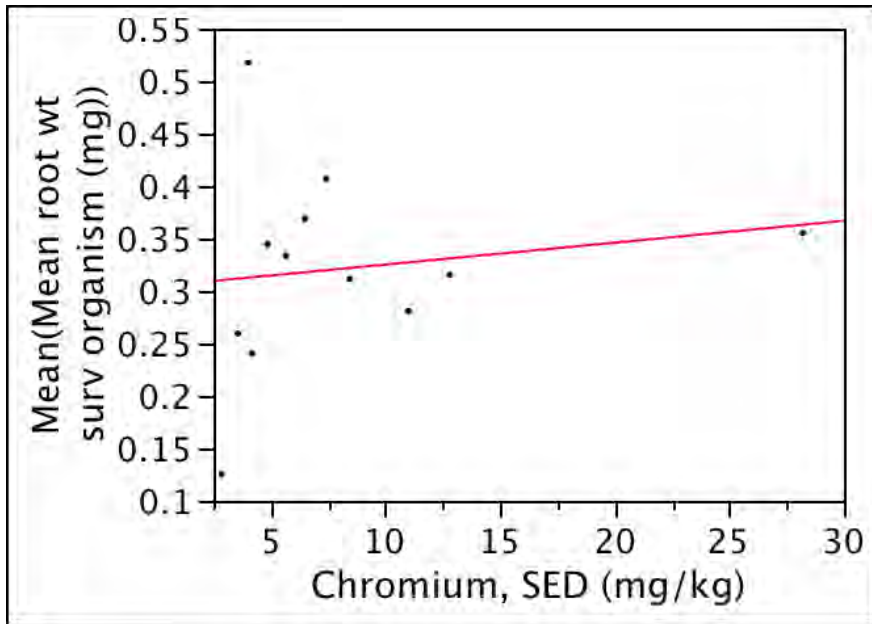

Figure E-1.4-36 Bivariate plot of plant mean root weight in toxicity test versus chromium (COPEC) concentrations in soil sample used in test: $r^2 = 0.023$; $n = 12$; $p = 0.637$

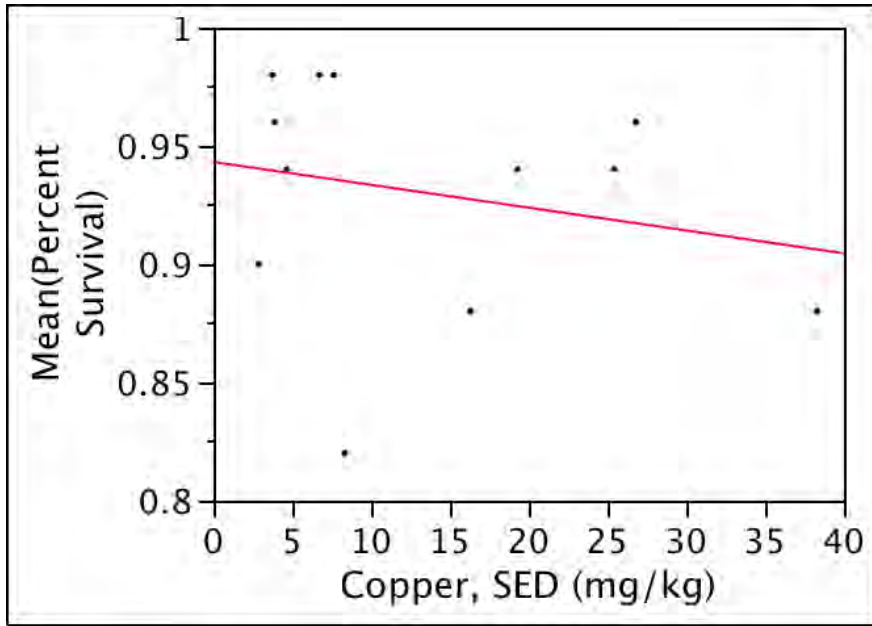

Figure E-1.4-37 Bivariate plot of plant survival in toxicity test versus copper (COPEC) concentrations in soil sample used in test: $r^2 = 0.049$; $n = 12$; $p = 0.488$

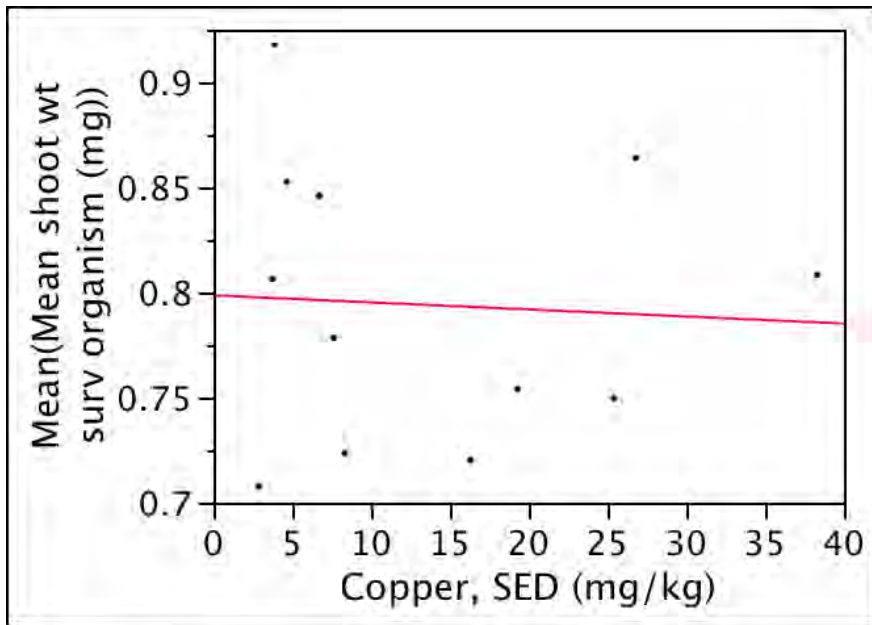

Figure E-1.4-38 Bivariate plot of plant mean shoot weight in toxicity test versus copper (COPEC) concentrations in soil sample used in test: $r^2 = 0.003$; $n = 12$; $p = 0.857$

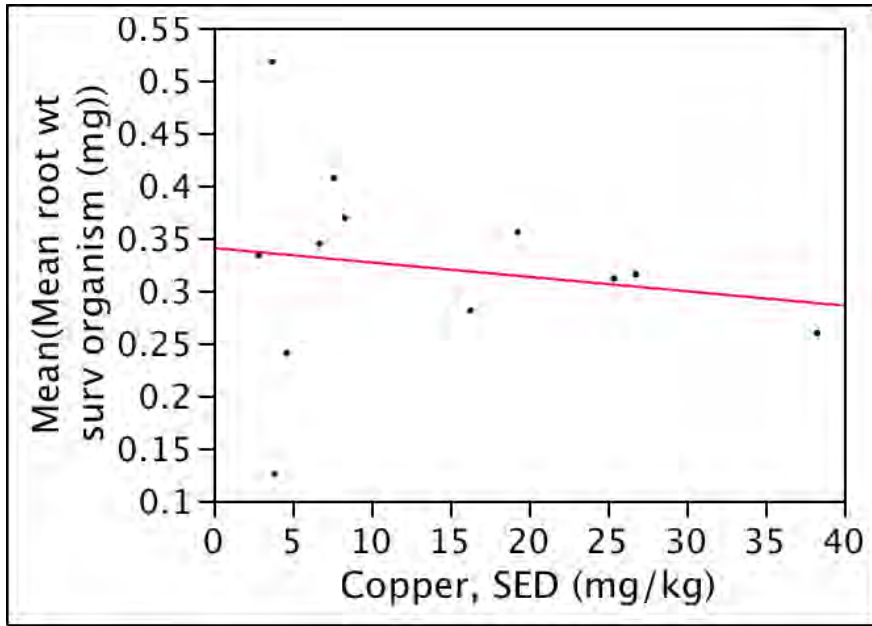

Figure E-1.4-39 Bivariate plot of plant mean root weight in toxicity test versus copper (COPEC) concentrations in soil sample used in test: $r^2 = 0.027$; $n = 12$; $p = 0.608$

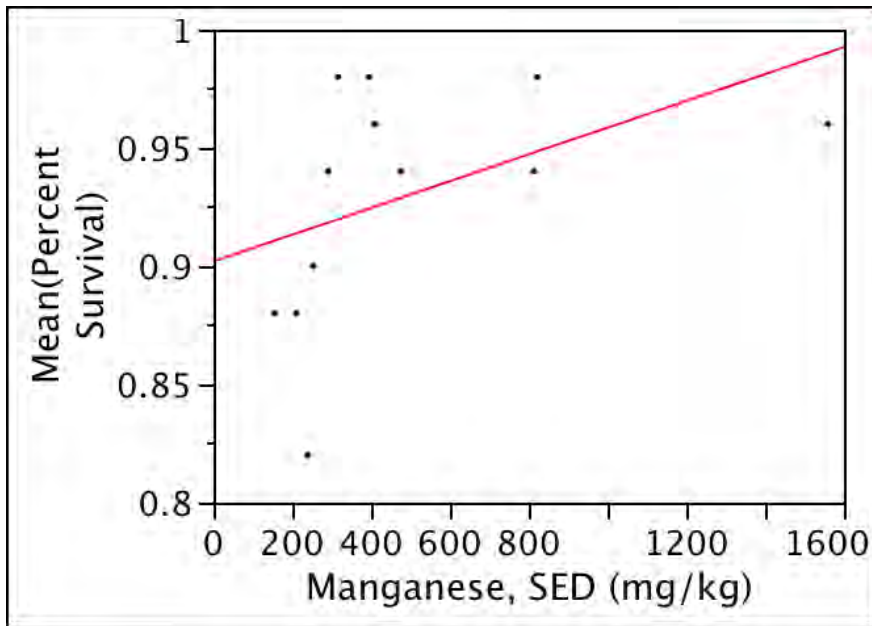

Figure E-1.4-40 Bivariate plot of plant survival in toxicity test versus manganese (COPEC) concentrations in soil sample used in test: $r^2 = 0.204$; $n = 12$; $p = 0.141$

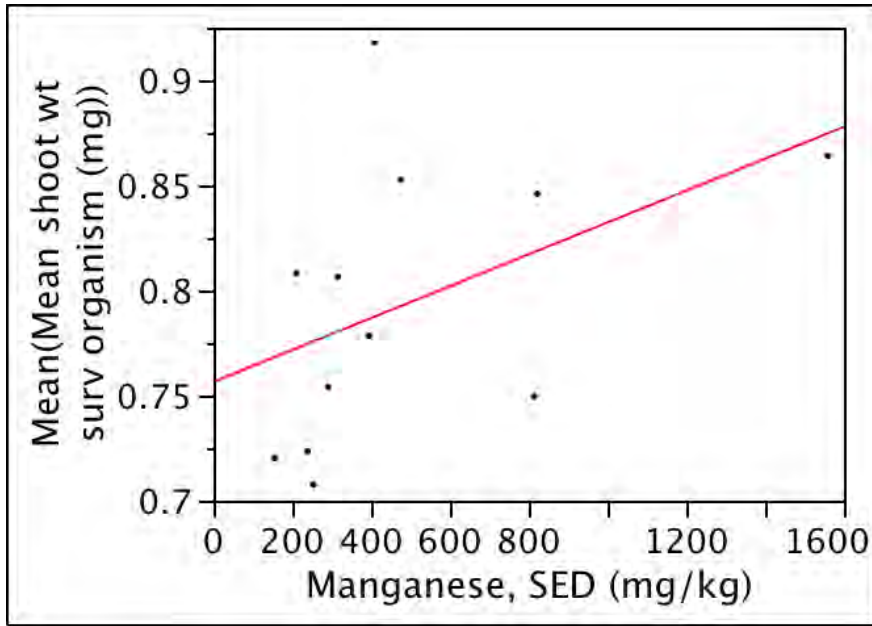

Figure E-1.4-41 Bivariate plot of plant mean shoot weight in toxicity test versus manganese (COPEC) concentrations in soil sample used in test: $r^2 = 0.208$; $n = 12$; $p = 0.136$

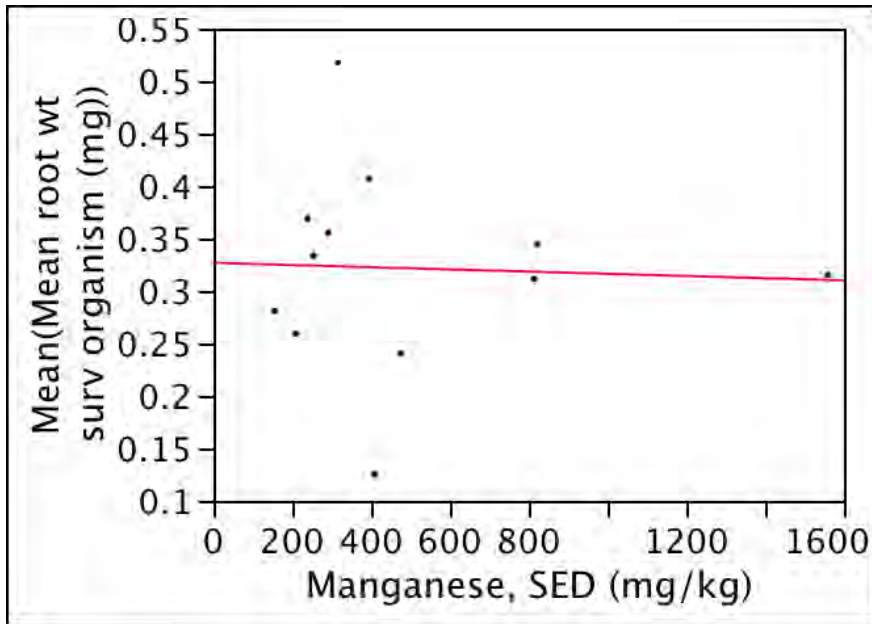

Figure E-1.4-42 Bivariate plot of plant mean root weight in toxicity test versus manganese (COPEC) concentrations in soil sample used in test: $r^2 = 0.002$; $n = 12$; $p = 0.893$

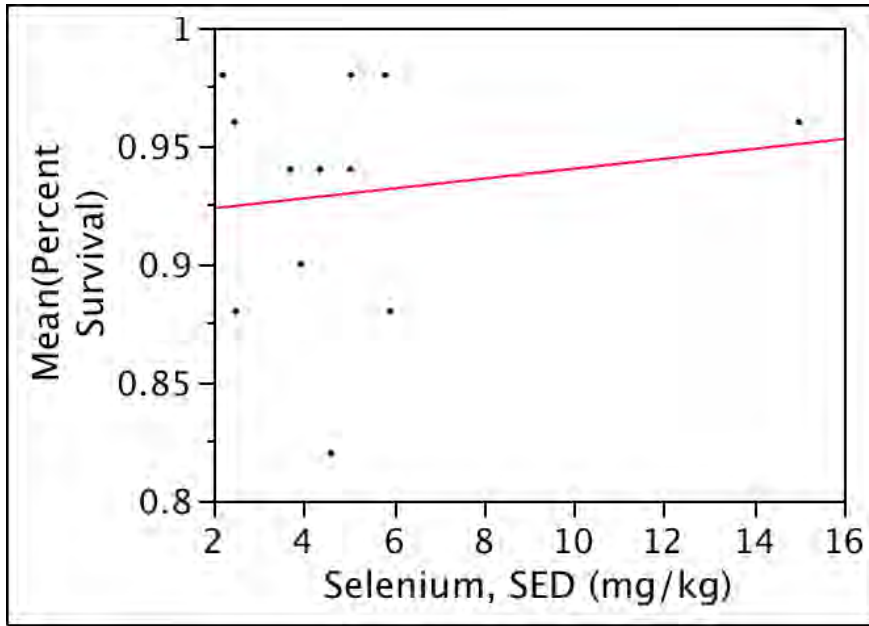

Figure E-1.4-43 Bivariate plot of plant survival in toxicity test versus selenium (COPEC) concentrations in soil sample used in test: $r^2=0.020$; $n=12$; $p=0.661$

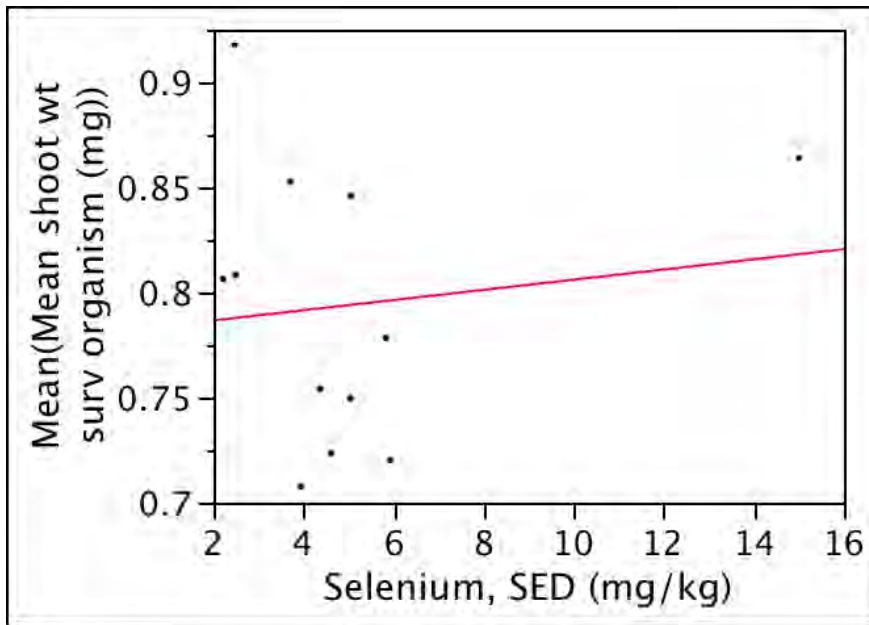

Figure E-1.4-44 Bivariate plot of plant mean shoot weight in toxicity test versus selenium (COPEC) concentrations in soil sample used in test: $r^2 = 0.015$; $n = 12$; $p = 0.703$

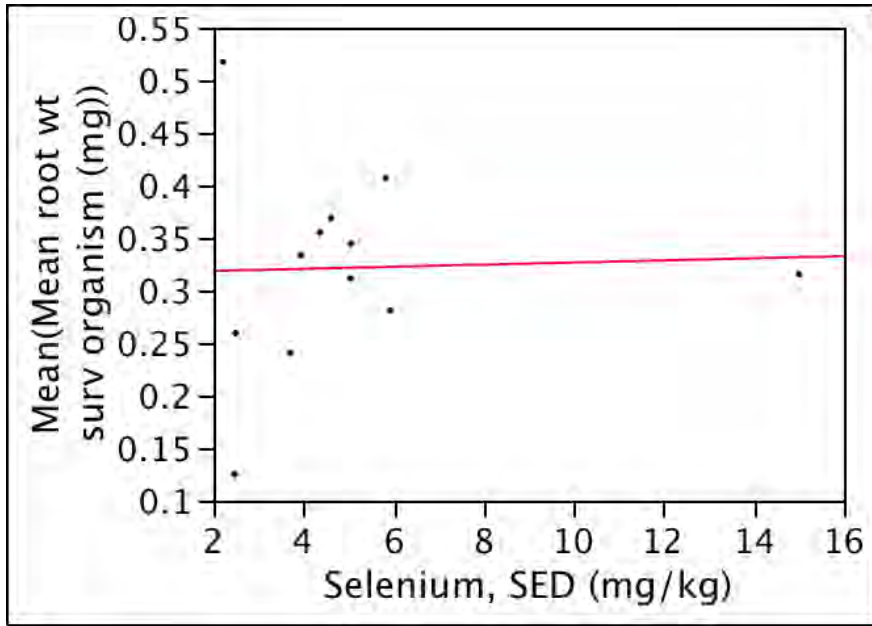

Figure E-1.4-45 Bivariate plot of plant mean root weight in toxicity test versus selenium (COPEC) concentrations in soil sample used in test: $r^2 = 0.001$; $n = 12$; $p = 0.912$

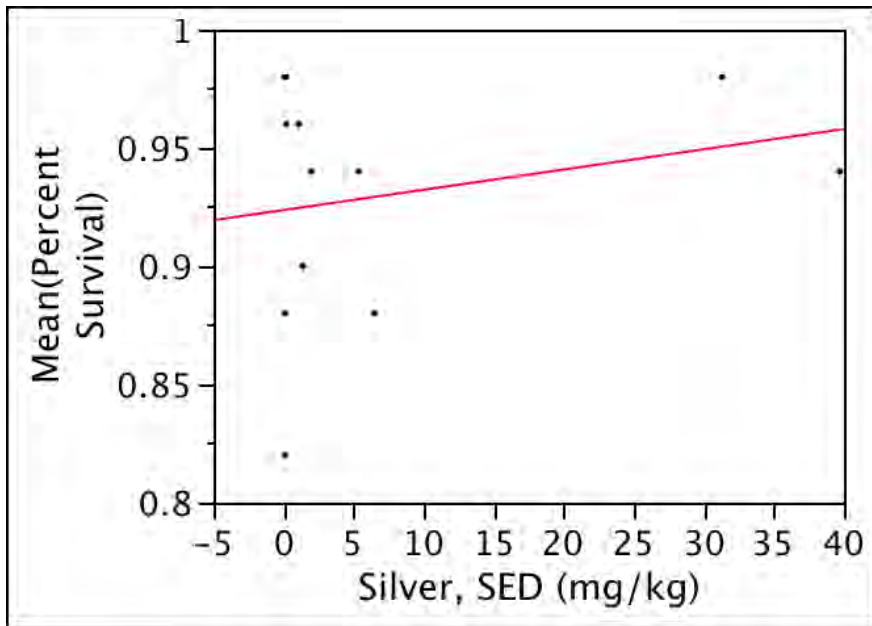

Figure E-1.4-46 Bivariate plot of plant survival in toxicity test versus silver (COPEC) concentrations in soil sample used in test: $r^2 = 0.053$; $n = 12$; $p = 0.472$

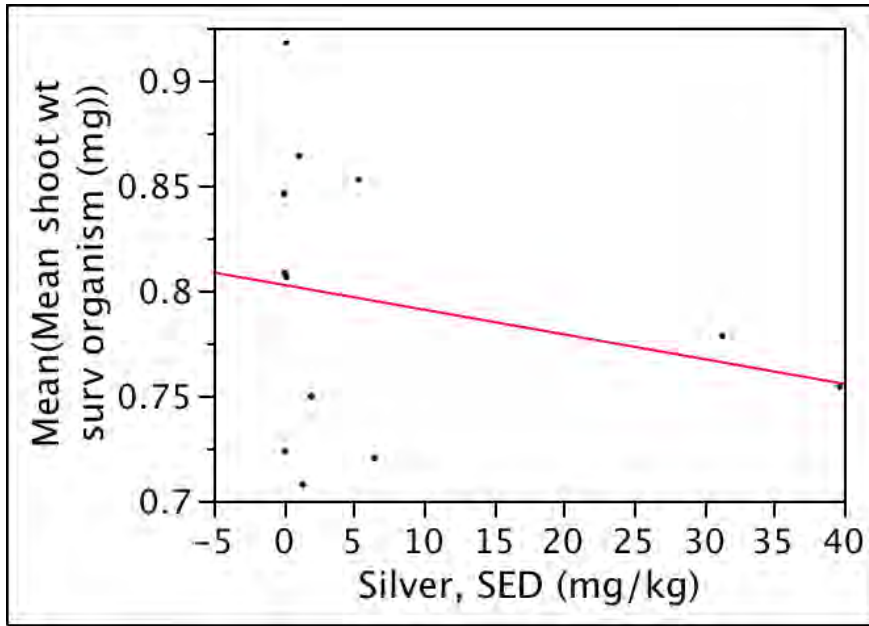

Figure E-1.4-47 Bivariate plot of plant mean shoot weight in toxicity test versus silver (COPEC) concentrations in soil sample used in test: $r^2 = 0.057$; $n = 12$; $p = 0.455$

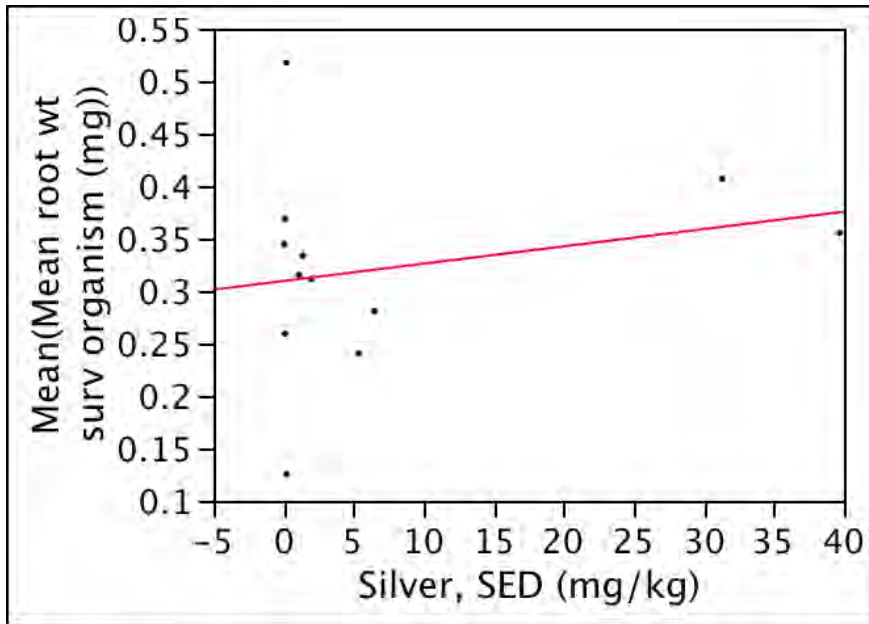

Figure E-1.4-48 Bivariate plot of plant mean root weight in toxicity test versus silver (COPEC) concentrations in soil sample used in test: $r^2 = 0.054$; $n = 12$; $p = 0.468$

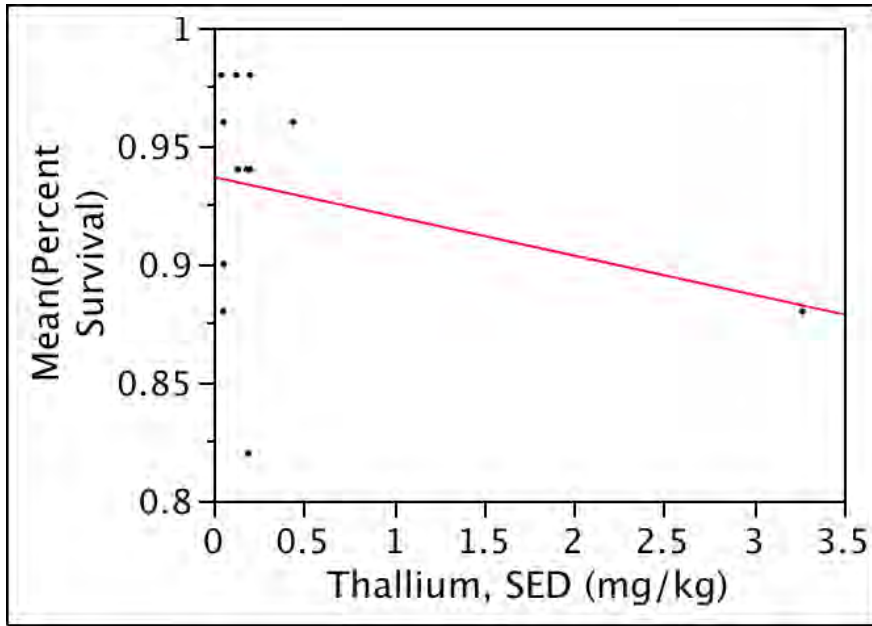

Figure E-1.4-49 Bivariate plot of plant survival in toxicity test versus thallium (COPEC) concentrations in soil sample used in test: $r^2 = 0.090$; $n = 12$; $p = 0.342$

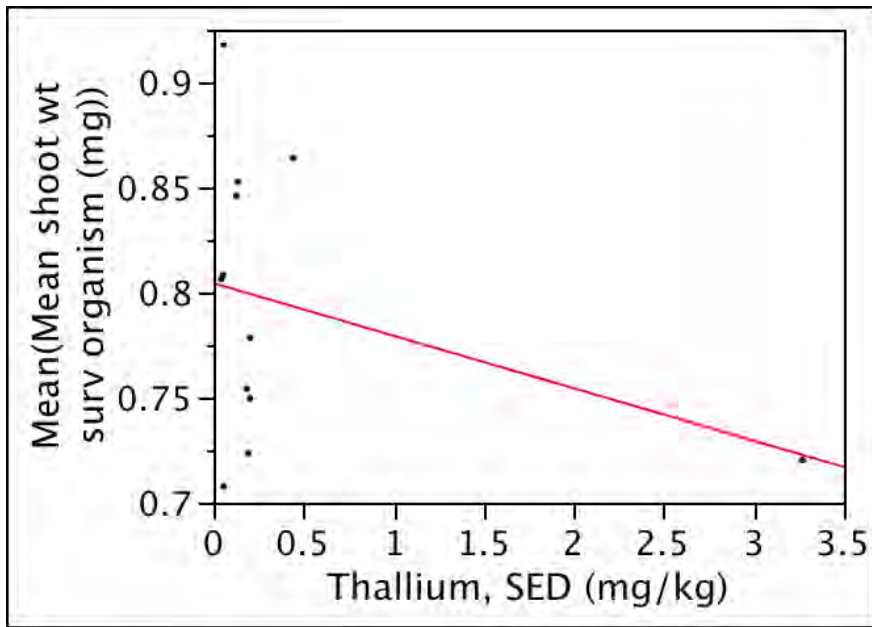

Figure E-1.4-50 Bivariate plot of plant mean shoot weight in toxicity test versus thallium (COPEC) concentrations in soil sample used in test: $r^2 = 0.117$; $n = 12$; $p = 0.278$

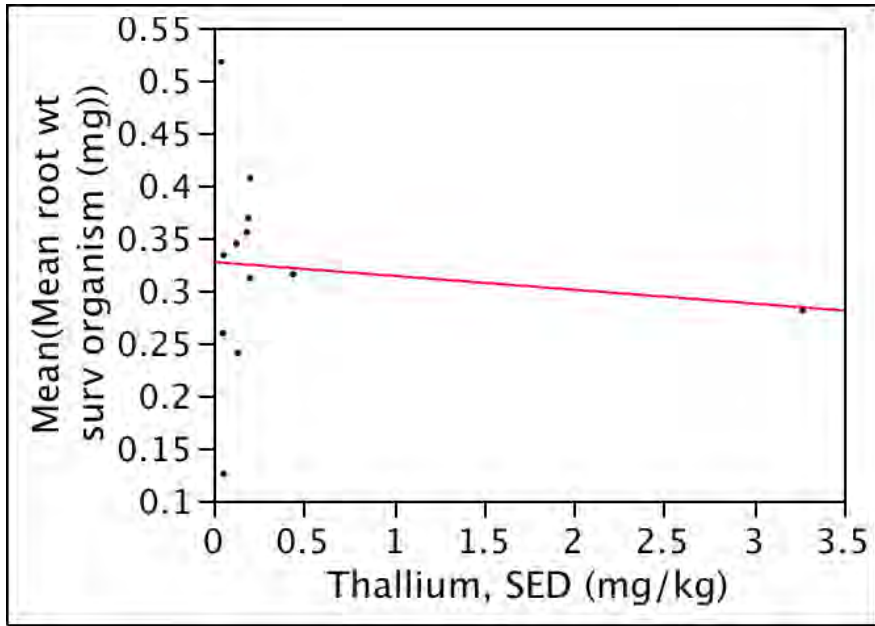

Figure E-1.4-51 Bivariate plot of plant mean root weight in toxicity test versus thallium (COPEC) concentrations in soil sample used in test: $r^2 = 0.016$; $n = 12$; $p = 0.699$

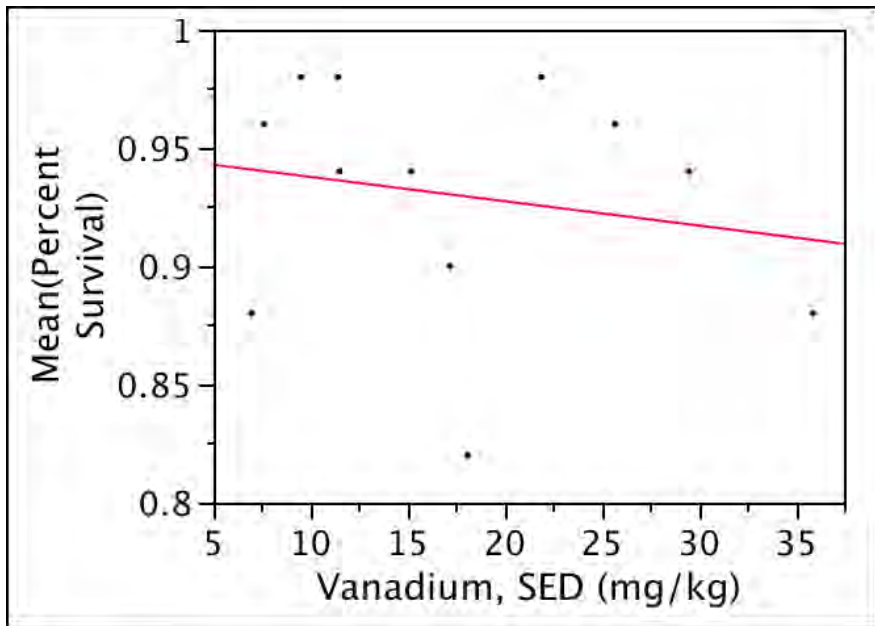

Figure E-1.4-52 Bivariate plot of plant survival in toxicity test versus vanadium (COPEC) concentrations in soil sample used in test: $r^2 = 0.035$; $n = 12$; $p = 0.559$

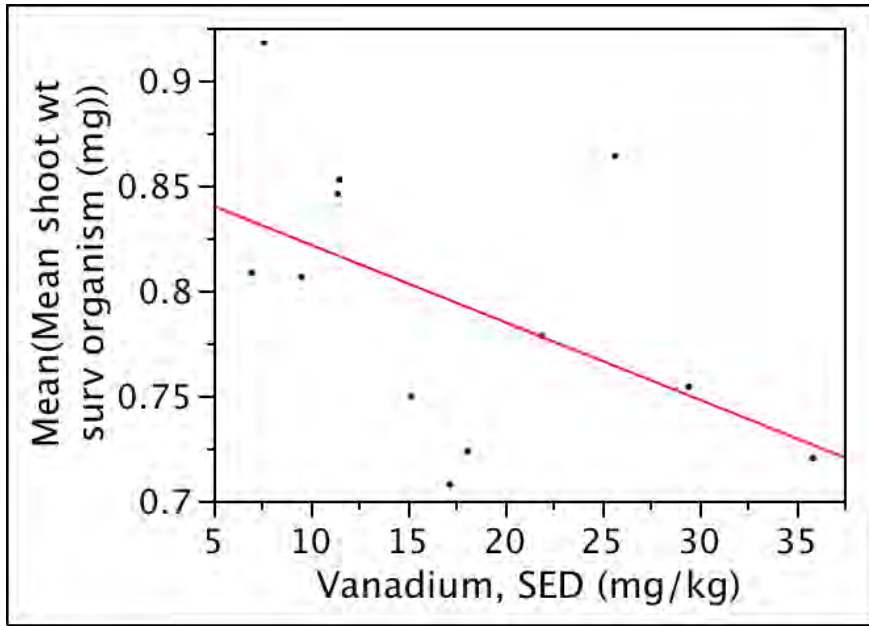

Figure E-1.4-53 Bivariate plot of plant mean shoot weight in toxicity test versus vanadium (COPEC) concentrations in soil sample used in test: $r^2 = 0.257$; $n = 12$; $p = 0.092$

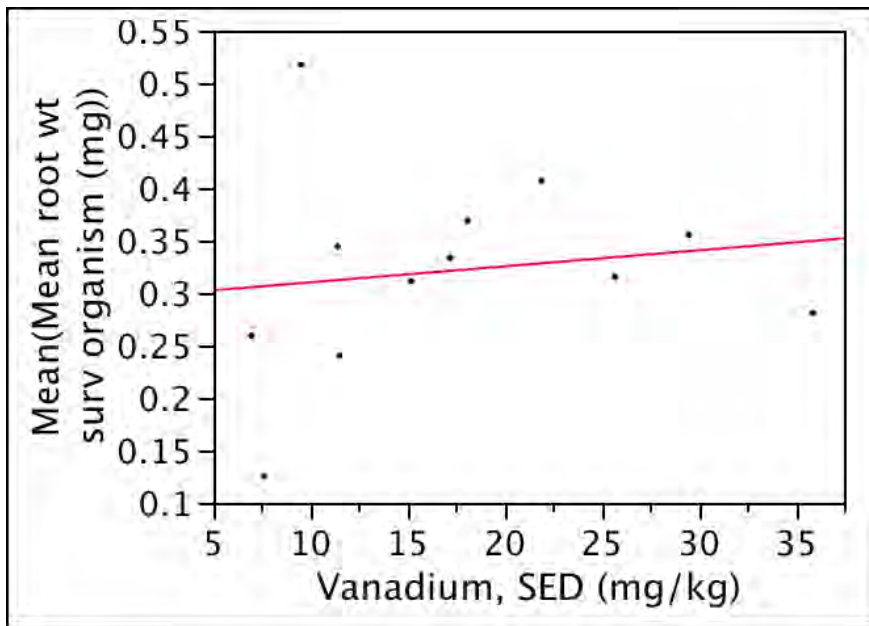

Figure E-1.4-54 Bivariate plot of plant mean root weight in toxicity test versus vanadium (COPEC) concentrations in soil sample used in test: $r^2 = 0.021$; $n = 12$; $p = 0.651$

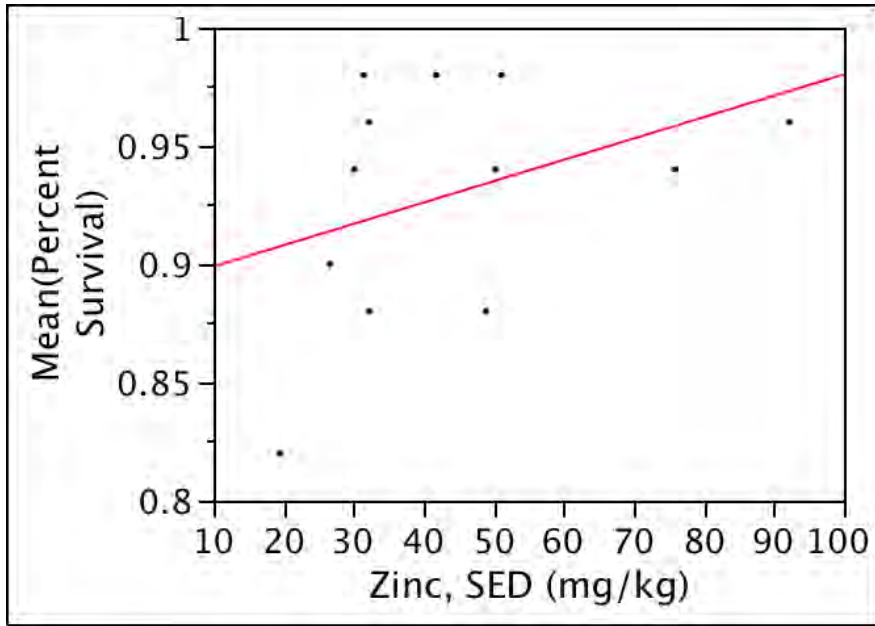

Figure E-1.4-55 Bivariate plot of plant survival in toxicity test versus zinc (COPEC) concentrations in soil sample used in test: $r^2 = 0.148$; $n = 12$; $p = 0.218$

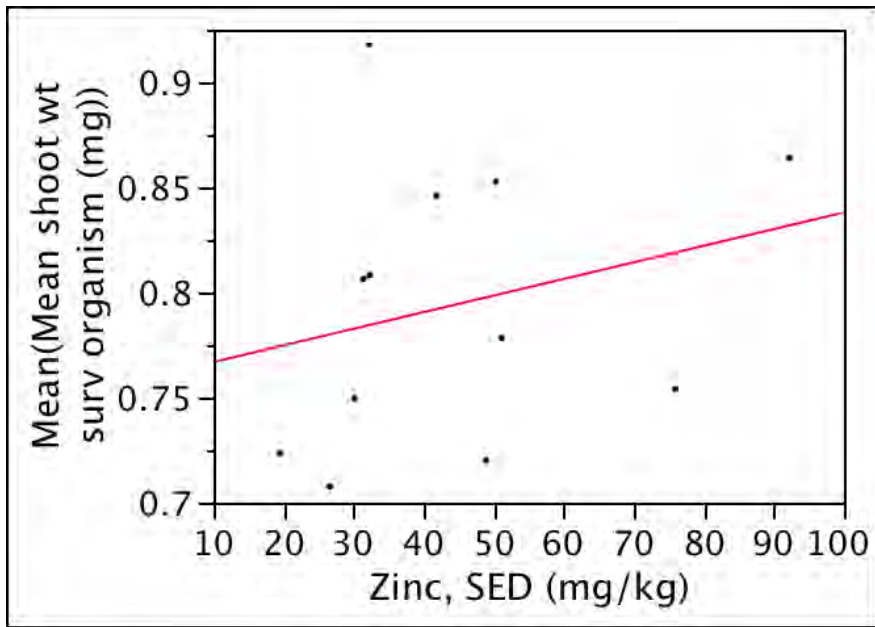

Figure E-1.4-56 Bivariate plot of plant mean shoot weight in toxicity test versus zinc (COPEC) concentrations in soil sample used in test: $r^2 = 0.064$; $n = 12$; $p = 0.426$

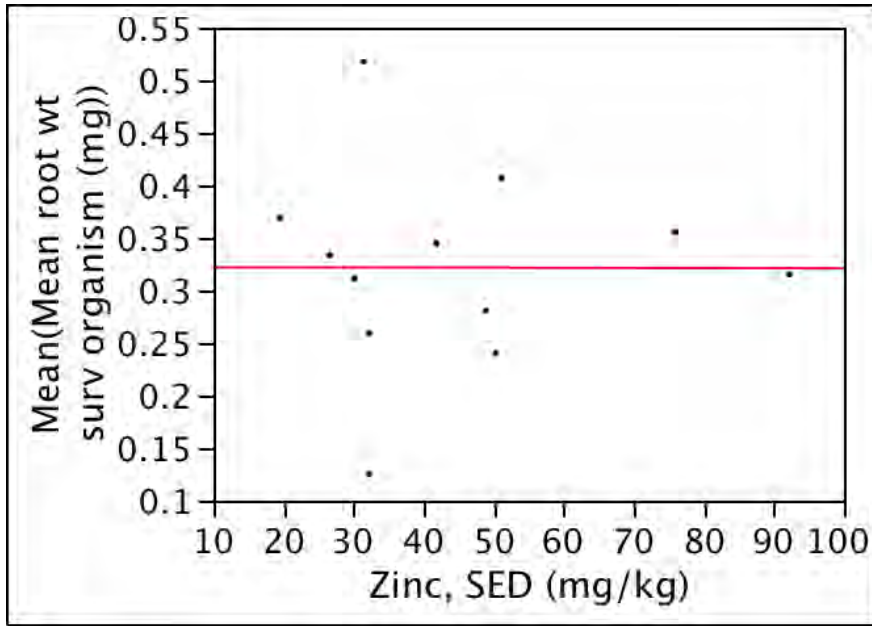

Figure E-1.4-57 Bivariate plot of plant mean root weight in toxicity test versus zinc (COPEC) concentrations in soil sample used in test: $r^2 < 0.0001$; $n = 12$; $p = 0.995$

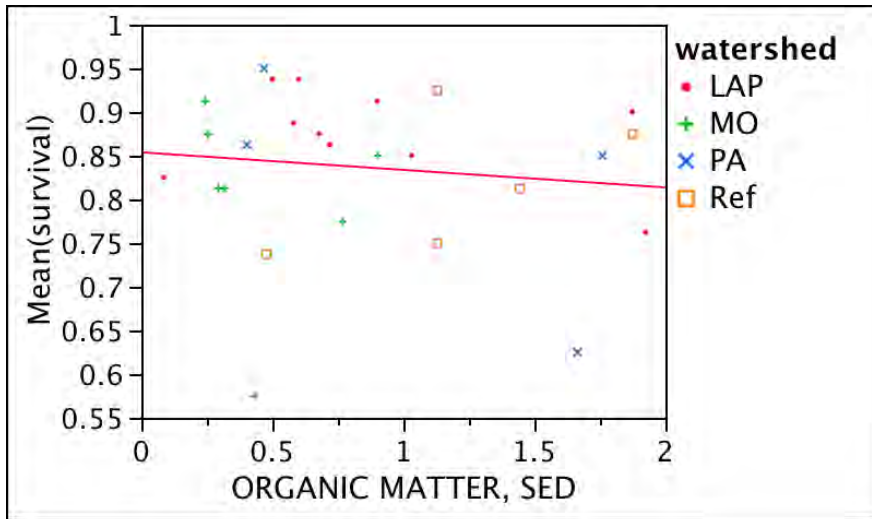

Figure E-1.5-1 Bivariate plot of chironomid survival versus organic matter (potential confounding factor): $r^2 = 0.016$; $n = 26$; $p = 0.539$

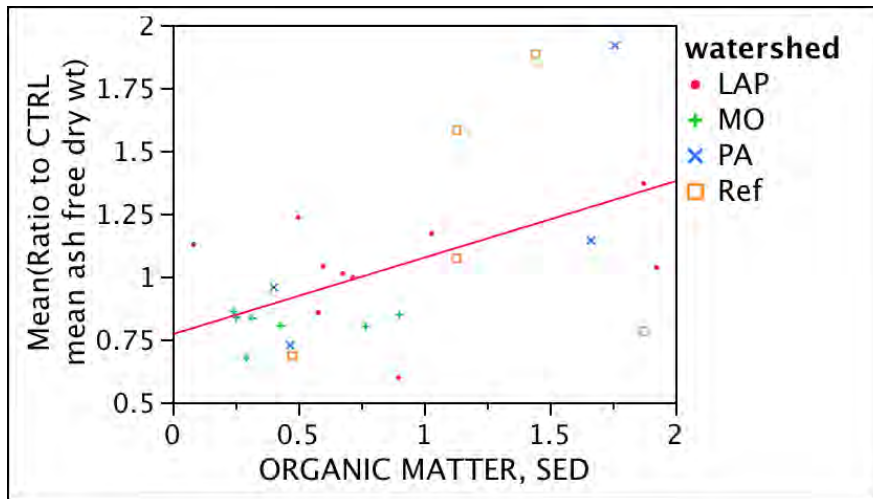

Figure E-1.5-2 Bivariate plot of chironomid growth versus organic matter (potential confounding factor): $r^2 = 0.262$; $n = 26$; $p = 0.008$

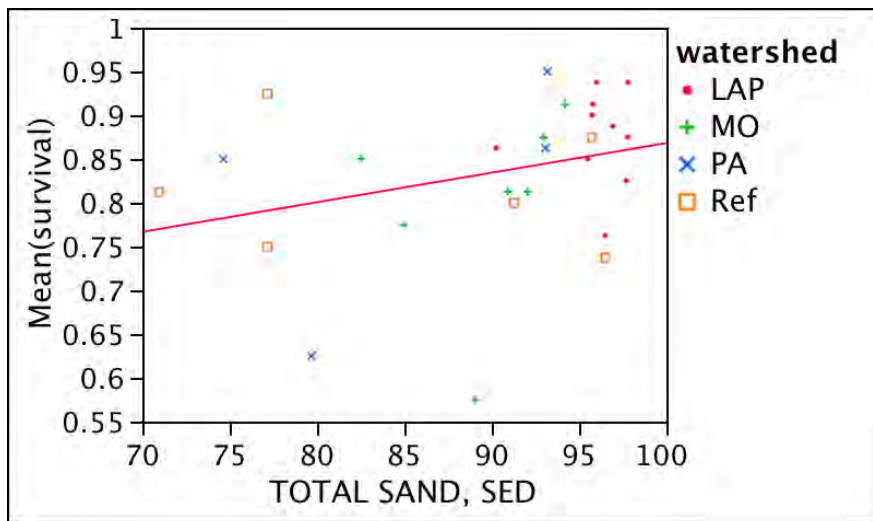

Figure E-1.5-3 Bivariate plot of chironomid survival versus sand-sized particle content (potential confounding factor): $r^2 = 0.090$; $n = 27$; $p = 0.128$

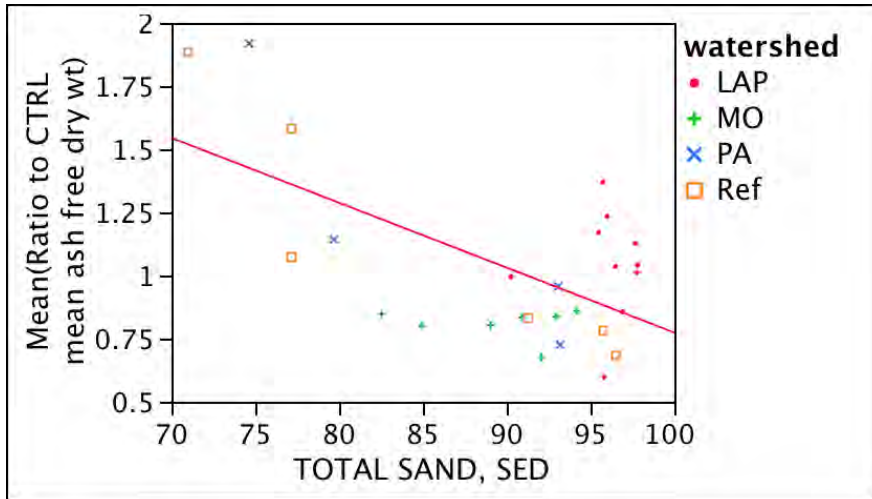

Figure E-1.5-4 Bivariate plot of chironomid growth versus sand-sized particle content (potential confounding factor): $r^2 = 0.372$; $n = 27$; $p = 0.0007$

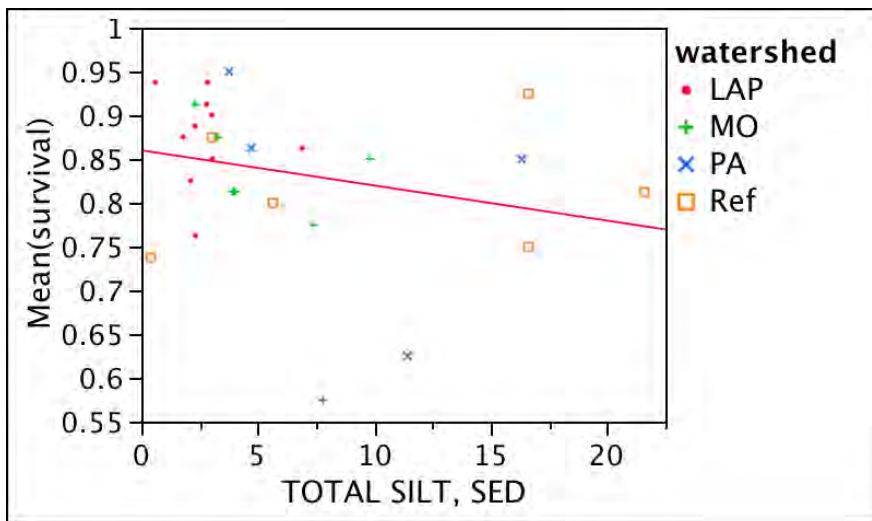

Figure E-1.5-5 Bivariate plot of chironomid survival versus silt-sized particle content (potential confounding factor): $r^2 = 0.064$; $n = 27$; $p = 0.203$

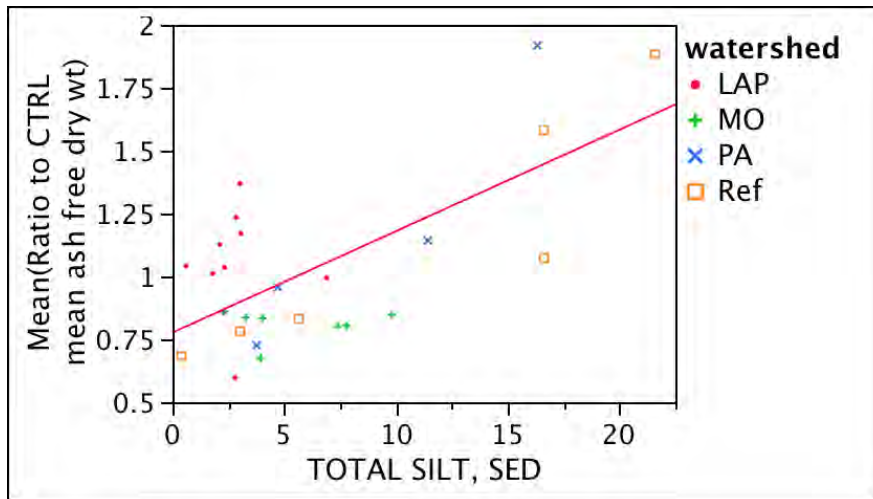

Figure E-1.5-6 Bivariate plot of chironomid growth versus silt-sized particle content (potential confounding factor): $r^2 = 0.460$; $n = 27$; $p = 0.0001$

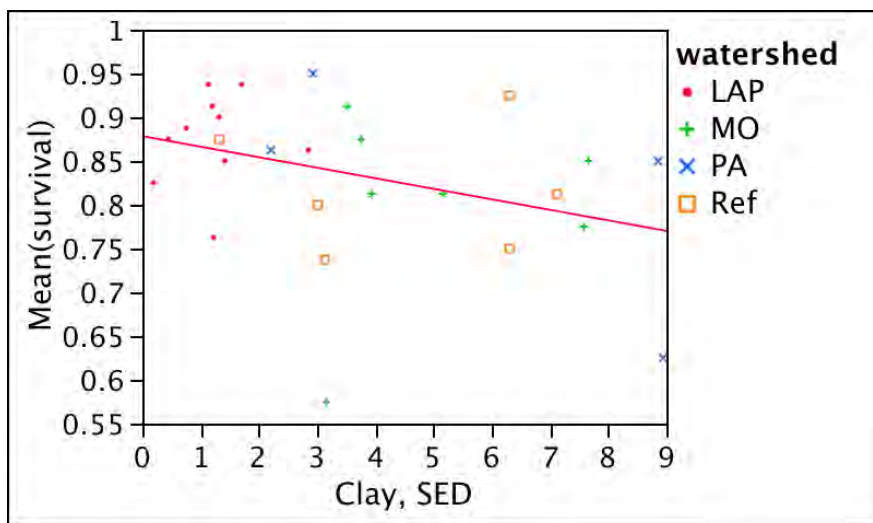

Figure E-1.5-7 Bivariate plot of chironomid survival versus clay-sized particle content (potential confounding factor): $r^2 = 0.131$; $n = 27$; $p = 0.064$.

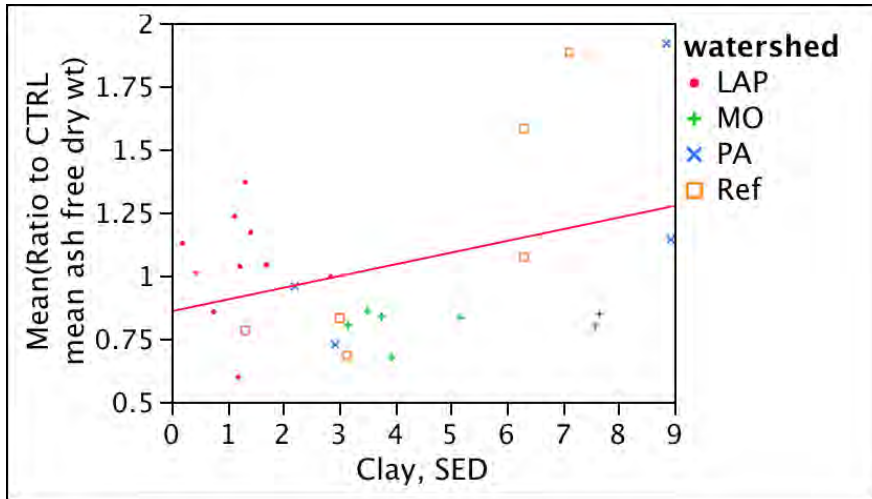

Figure E-1.5-8 Bivariate plot of chironomid growth versus clay-sized particle content (potential confounding factor): $r^2 = 0.138$; $n = 27$; $p = 0.057$

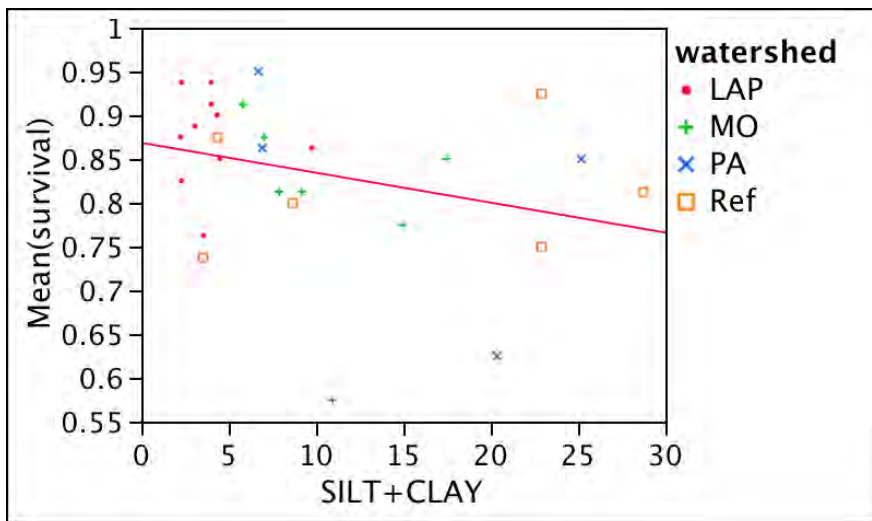

Figure E-1.5-9 Bivariate plot of chironomid survival versus silt+clay-sized particle content (potential confounding factor): $r^2 = 0.092$; $n = 27$; $p = 0.125$

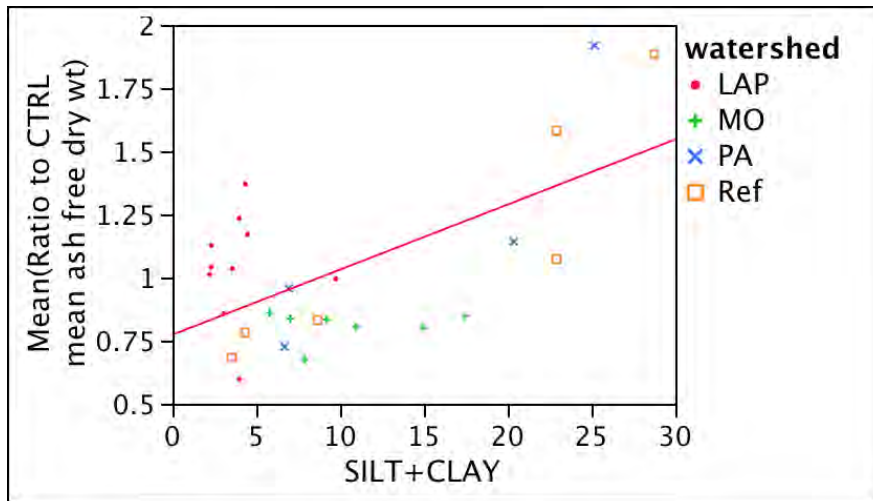

Figure E-1.5-10 Bivariate plot of chironomid growth versus silt+clay-sized particle content (potential confounding factor): $r^2 = 0.370$; $n = 27$; $p = 0.0008$

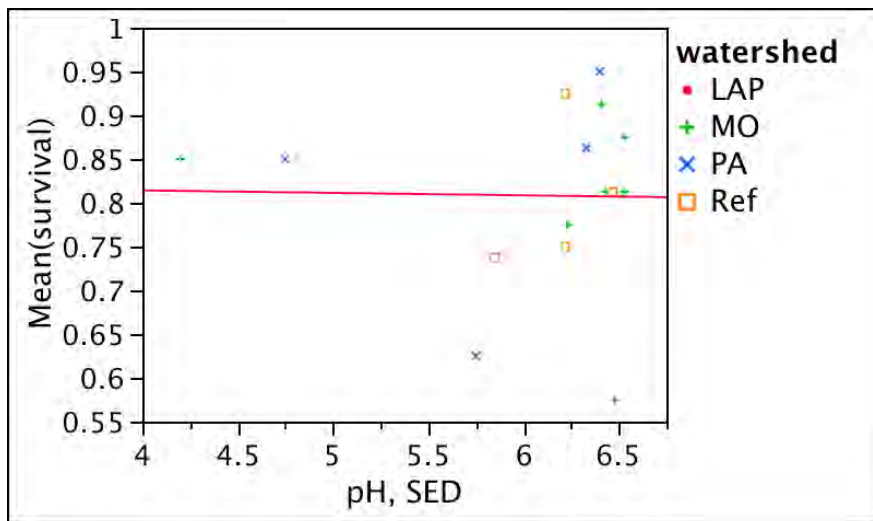

Figure E-1.5-11 Bivariate plot of chironomid survival versus pH (potential confounding factor): $r^2 = 0.0004$; $n = 15$; $p = 0.947$

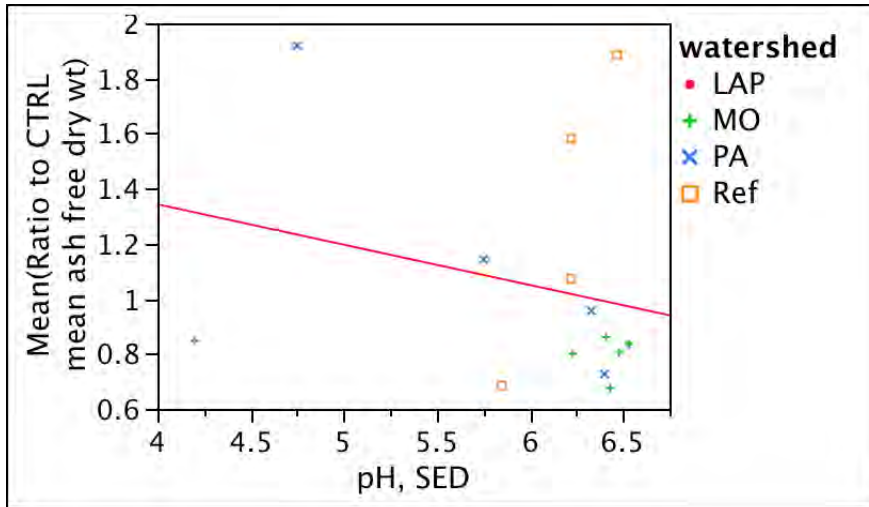

Figure E-1.5-12 Bivariate plot of chironomid growth versus pH (potential confounding factor): $r^2 = 0.059$; $n = 15$; $p = 0.384$

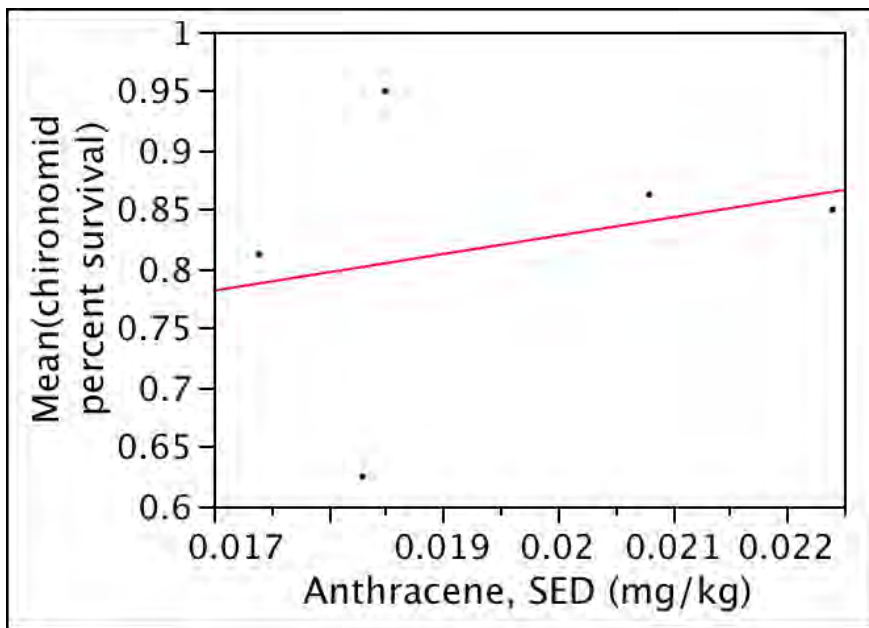

Figure E-1.5-13 Bivariate plot of chironomid survival versus anthracene (COPEC): $r^2 = 0.070$; $n = 5$; $p = 0.667$

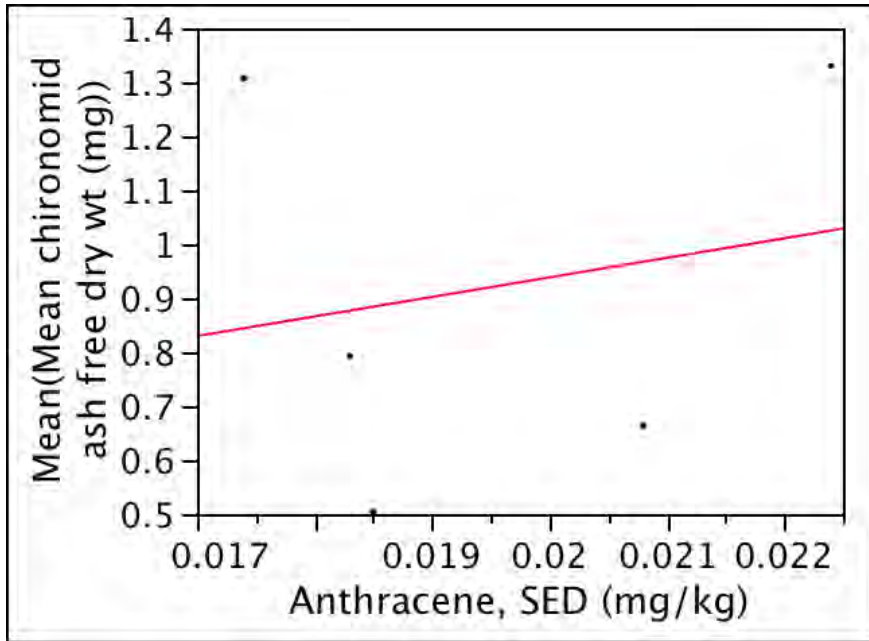

Figure E-1.5-14 Bivariate plot of chironomid growth versus anthracene (COPEC): $r^2 = 0.039$; $n = 5$; $p = 0.751$.

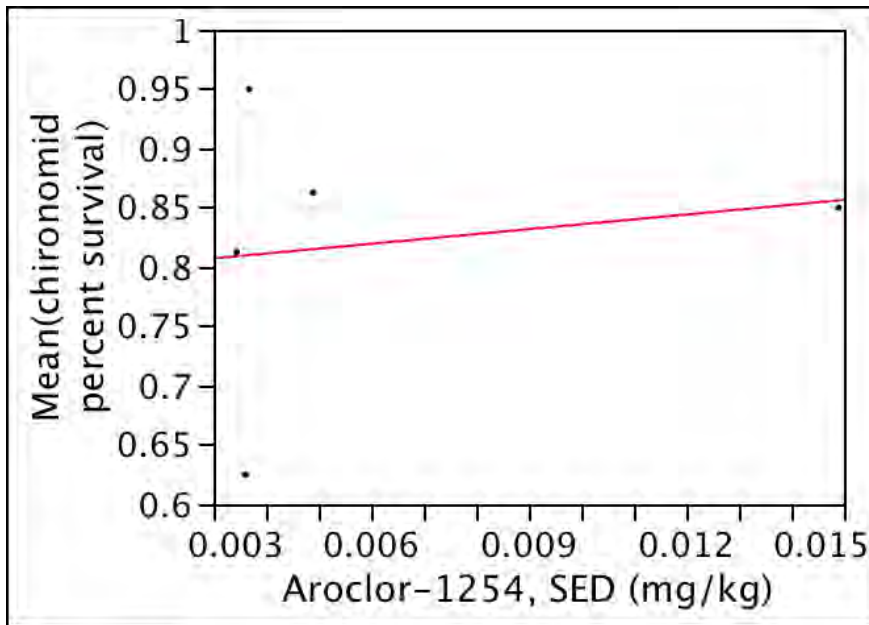

Figure E-1.5-15 Bivariate plot of chironomid survival versus Aroclor-1254 (COPEC): $r^2 = 0.029$; $n = 5$; $p = 0.785$

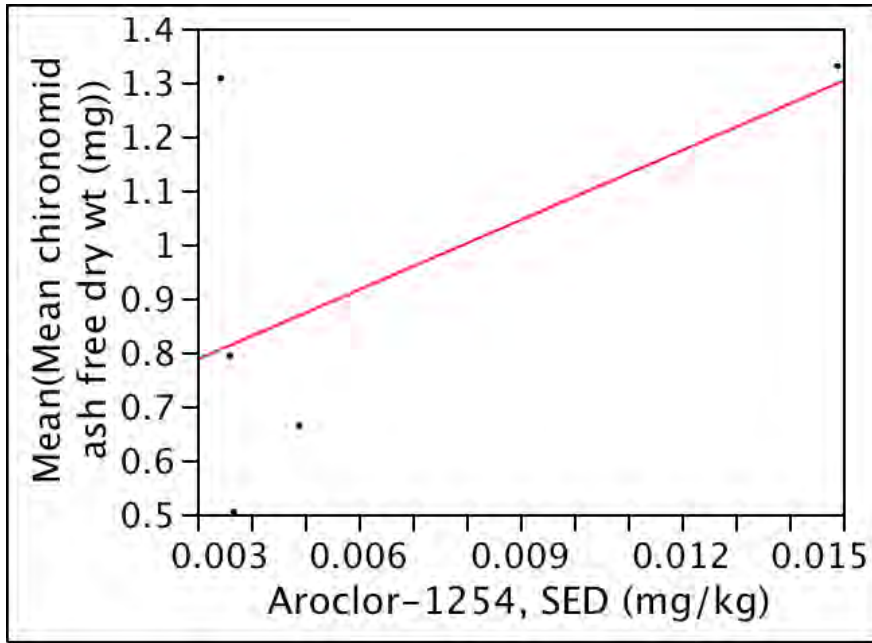

Figure E-1.5-16 Bivariate plot of chironomid growth versus Aroclor-1254 (COPEC): $r^2 = 0.316$; $n = 5$; $p = 0.324$

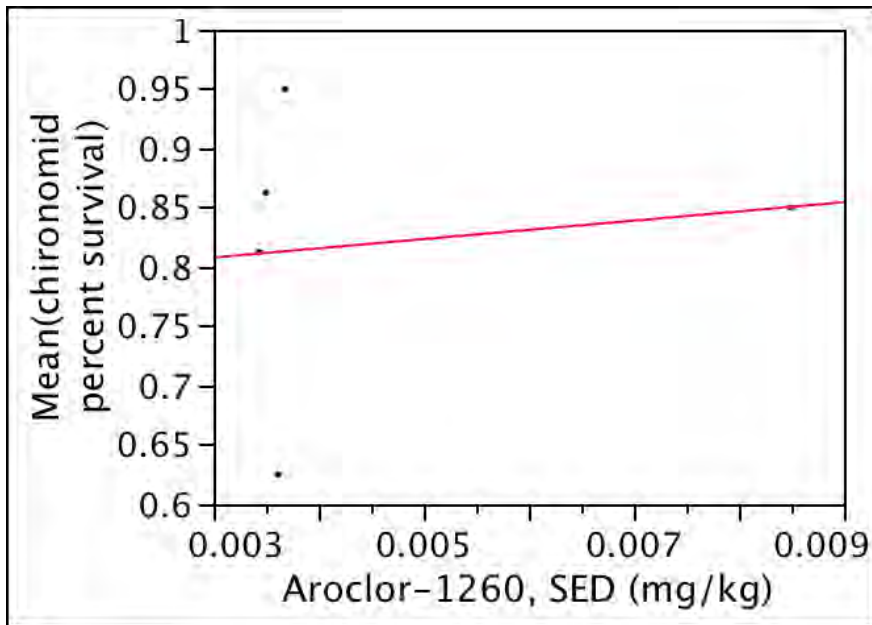

Figure E-1.5-17 Bivariate plot of chironomid survival versus Aroclor-1260 (COPEC): $r^2 = 0.021$; $n = 5$; $p = 0.818$

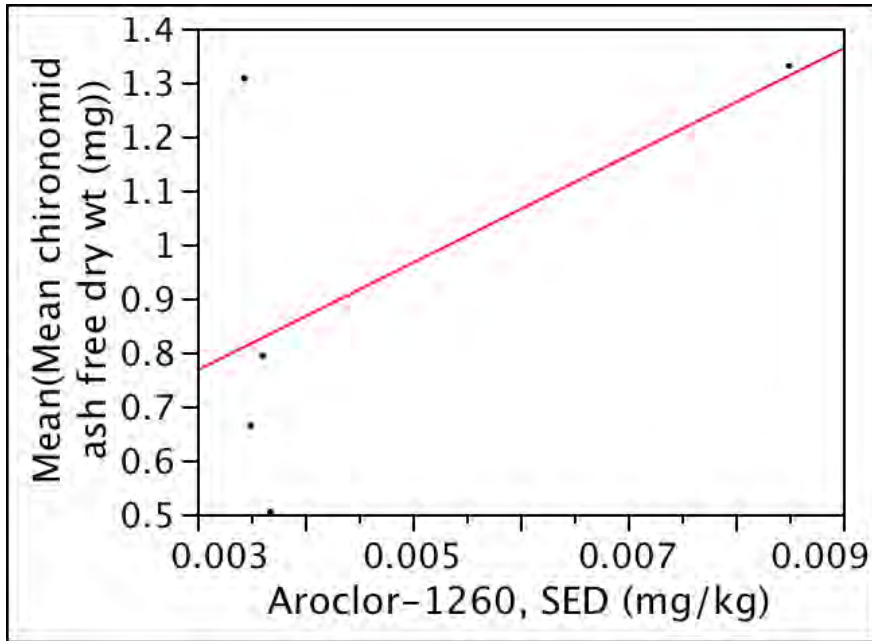

Figure E-1.5-18 Bivariate plot of chironomid growth versus Aroclor-1260 (COPEC): $r^2 = 0.336$; $n = 5$; $p = 0.306$

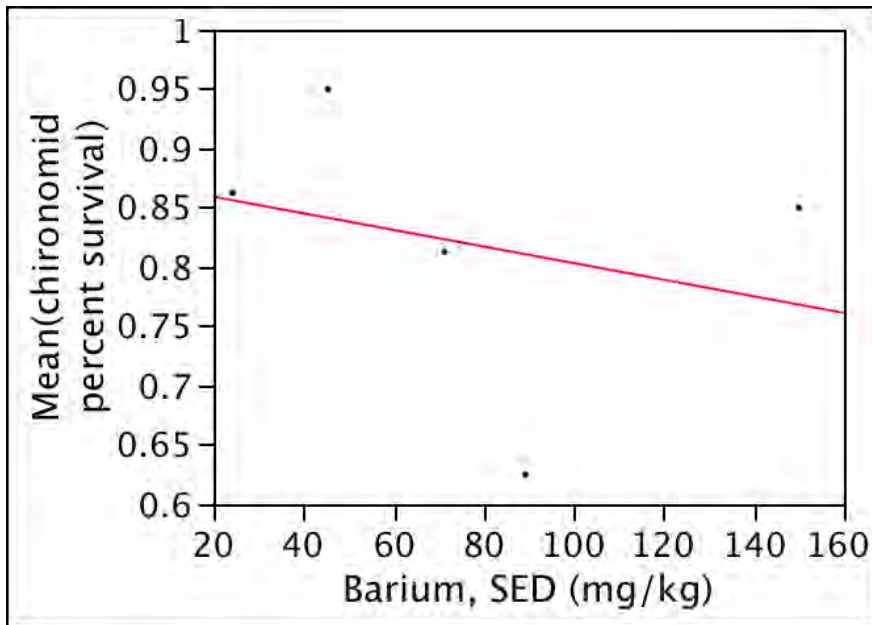

Figure E-1.5-19 Bivariate plot of chironomid survival versus barium (COPEC): $r^2 = 0.079$; $n = 5$; $p = 0.647$

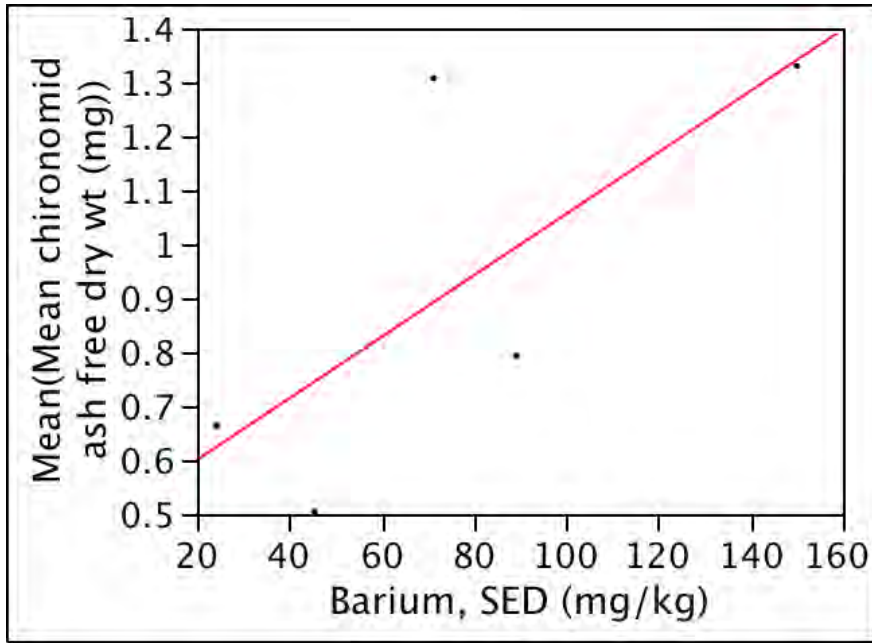

Figure E-1.5-20 Bivariate plot of chironomid growth versus barium (COPEC): $r^2 = 0.525$; $n = 5$; $p = 0.166$

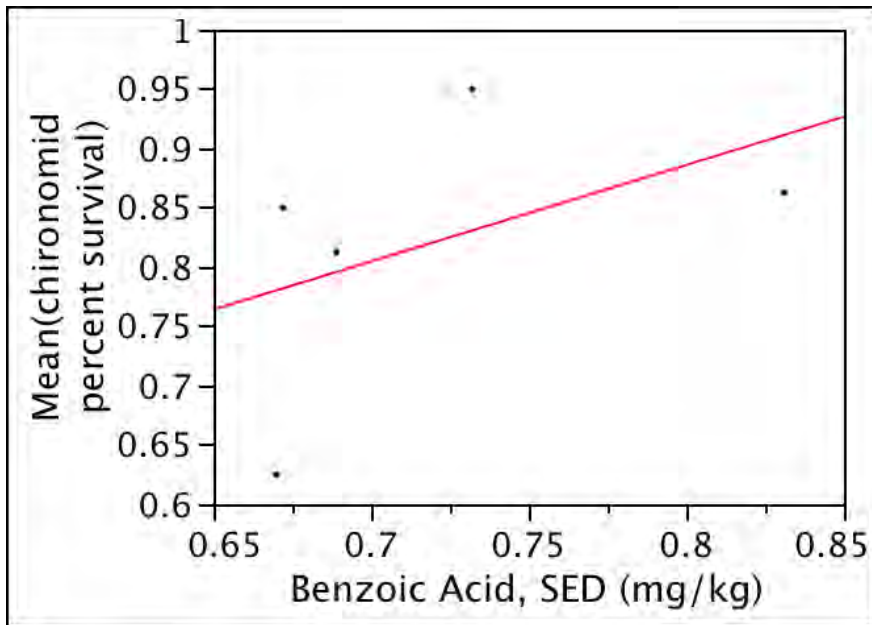

Figure E-1.5-21 Bivariate plot of chironomid survival versus benzoic acid (COPEC): $r^2 = 0.209$; $n = 5$; $p = 0.439$

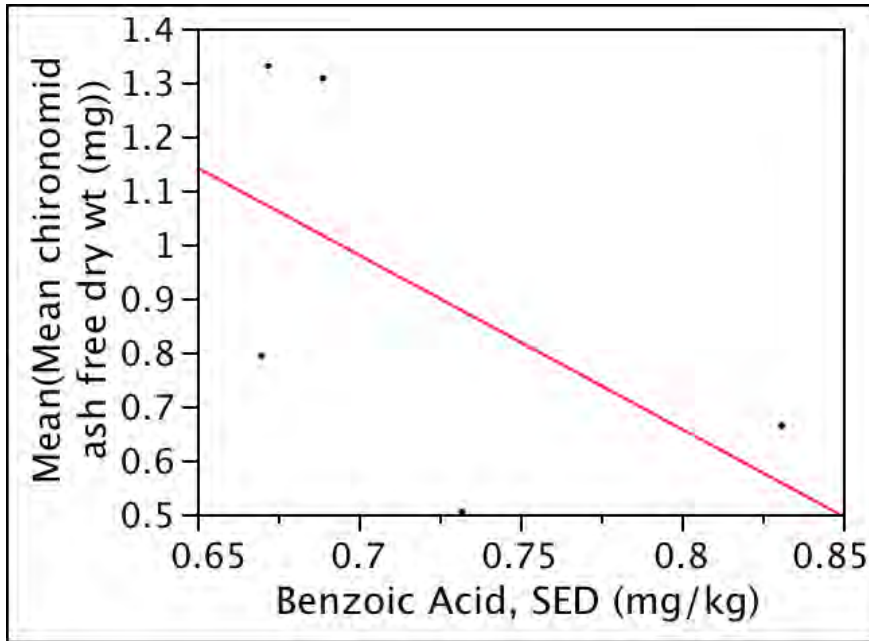

Figure E-1.5-22 Bivariate plot of chironomid growth versus benzoic acid (COPEC): $r^2 = 0.331$; $n = 5$; $p = 0.311$

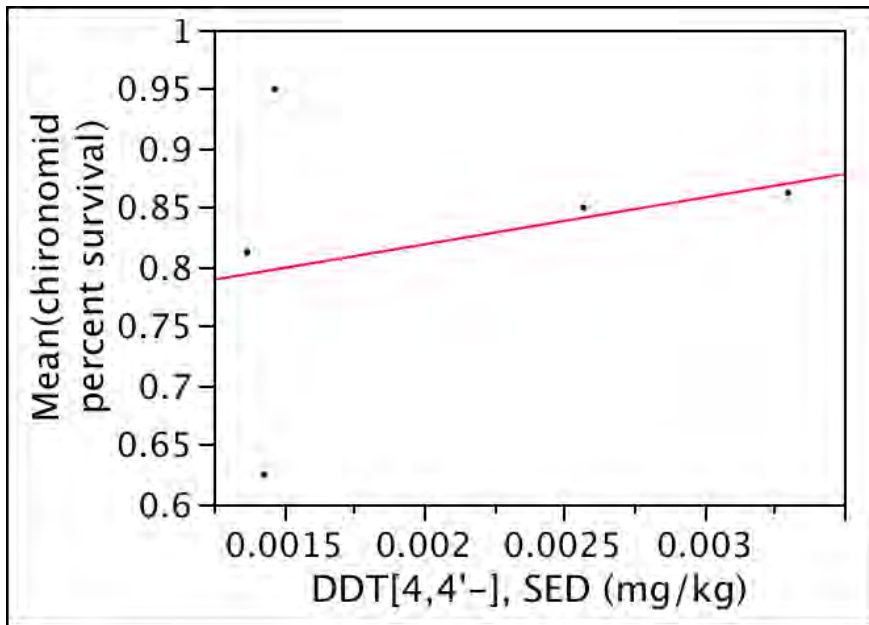

Figure E-1.5-23 Bivariate plot of chironomid survival versus 4,4'-DDT (COPEC): $r^2 = 0.082$; $n = 5$; $p = 0.641$

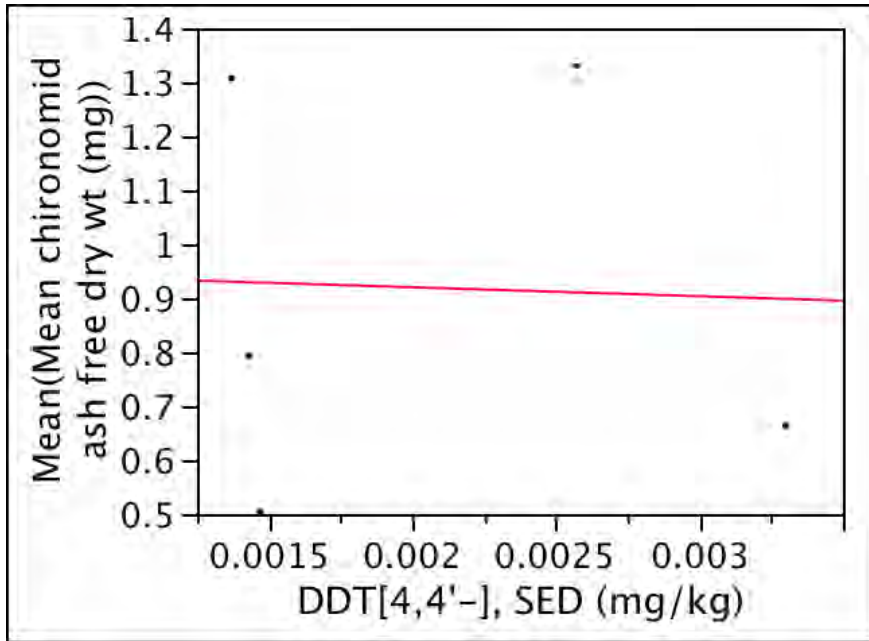

Figure E-1.5-24 Bivariate plot of chironomid growth versus 4,4'-DDT (COPEC): ; $r^2 = 0.001$; $n = 5$; $p = 0.952$

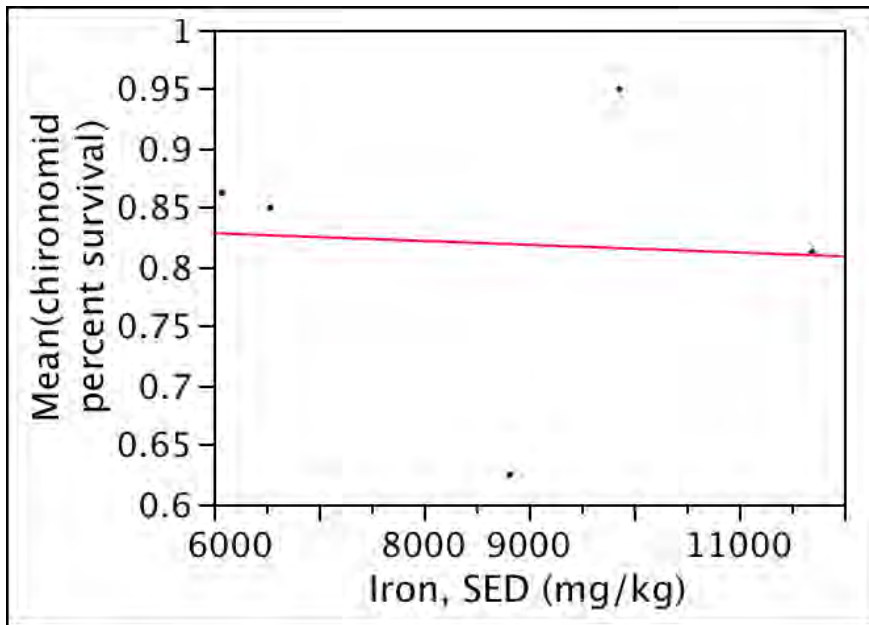

Figure E-1.5-25 Bivariate plot of chironomid survival versus iron (COPEC): $r^2 = 0.004$; $n = 5$; $p = 0.919$

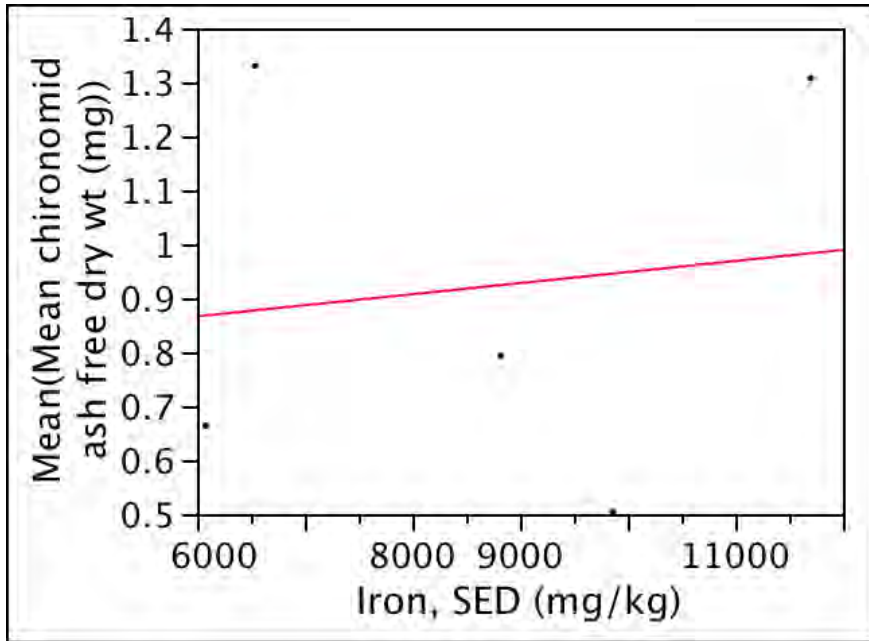

Figure E-1.5-26 Bivariate plot of chironomid growth versus iron (COPEC): $r^2 = 0.016$; $n = 5$; $p = 0.839$

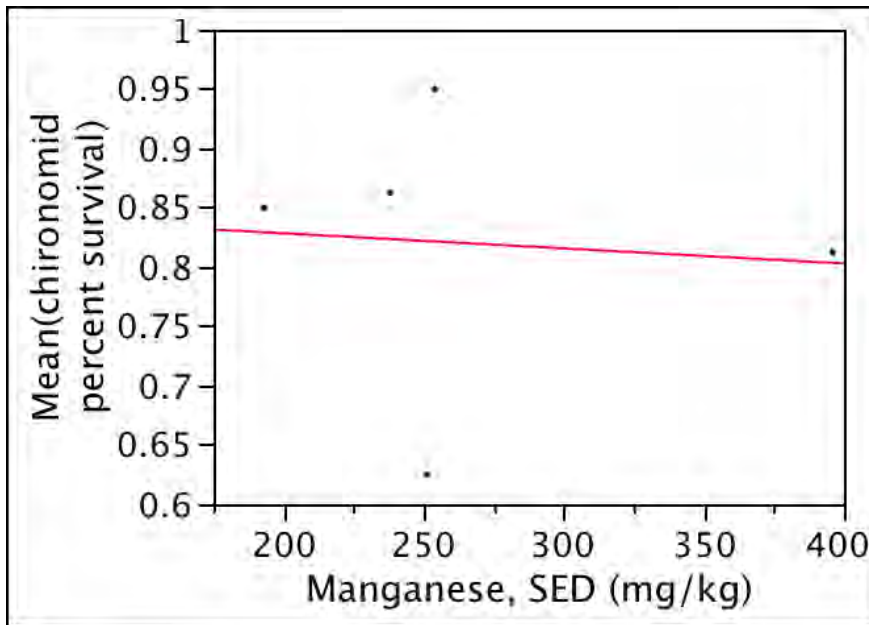

Figure E-1.5-27 Bivariate plot of chironomid survival versus manganese (COPEC): $r^2 = 0.007$; $n = 5$; $p = 0.897$

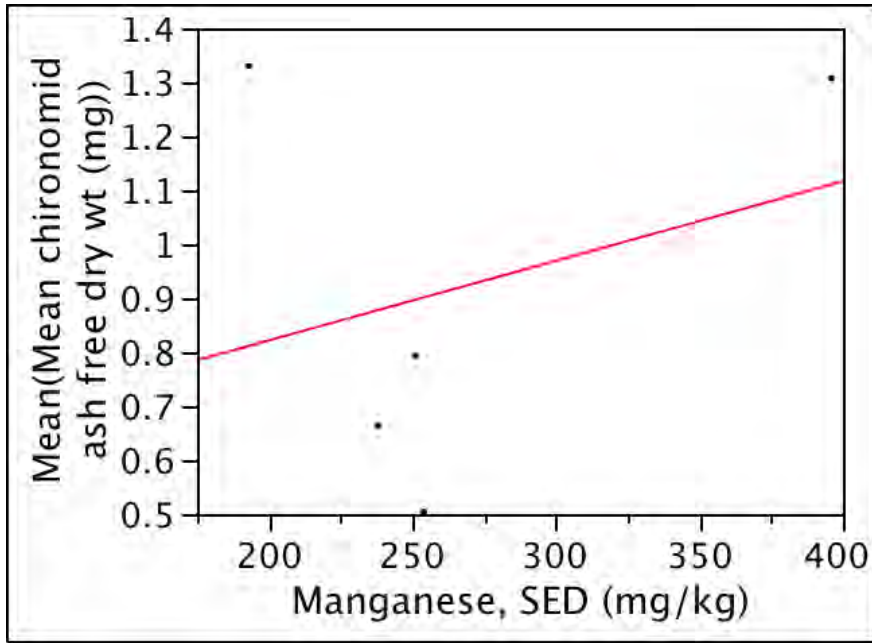

Figure E-1.5-28 Bivariate plot of chironomid growth versus manganese (COPEC): $r^2 = 0.089$; $n = 5$; $p = 0.627$

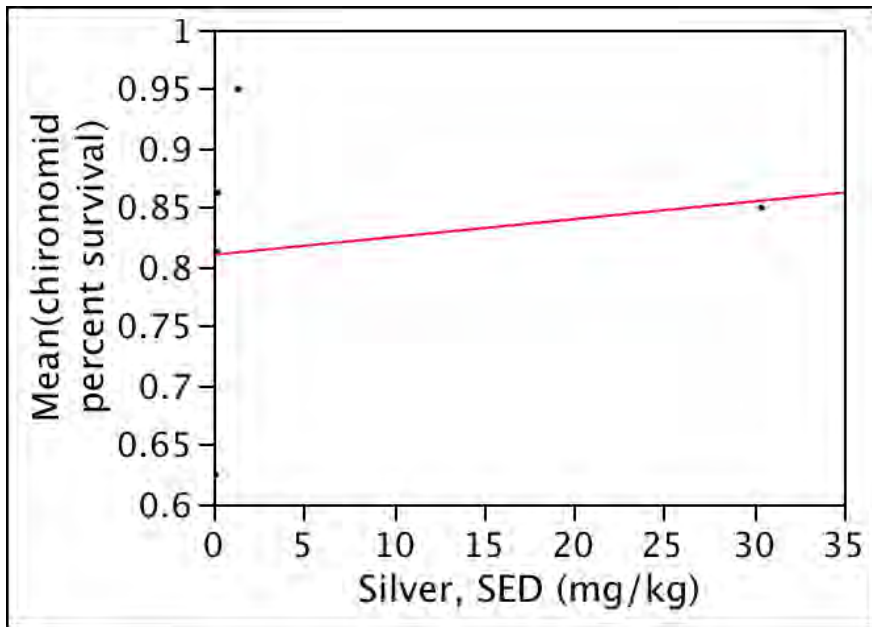

Figure E-1.5-29 Bivariate plot of chironomid survival versus silver (COPEC): $r^2 = 0.028$; $n = 5$; $p = 0.788$

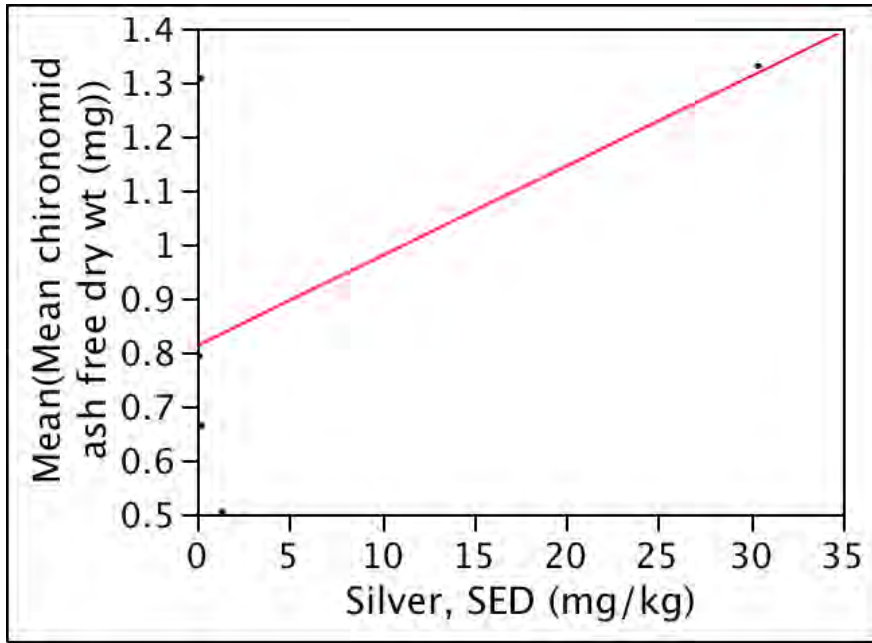

Figure E-1.5-30 Bivariate plot of chironomid growth versus silver (COPEC): $r^2 = 0.346$; $n = 5$; $p = 0.297$

**Table E-1.1-1
TRVs for the Ecological Exposure Evaluation**

COPEC	Avian TRV (mg/kg/d)	Mammalian TRV (mg/kg/d)
Aluminum	na*	na
Antimony	na	0.059
Aroclor-1248	0.1	0.0099
Aroclor-1254	0.1	0.611
Aroclor-1260	2.15	13.8
Barium	73.5	51.8
Bis[2-ethylhexyl]phthalate	1.1	18.3
Cadmium	1.7	0.77
Chromium	77	39.6
Copper	2.98	5.13
Cyanide [total]	0.04	68.7
Di-n-butylphthalate	0.14	1340
Iron	na	na
Lead	1.63	4.7
Mercury	0.019	1.41
Perchlorate	na	na
Silver	5.44	19
Tetrachlorodibenzodioxin[2,3,7,8-]	na	5.62E-07
Thallium	0.35	0.0071
Vanadium	0.344	4.16
Zinc	37.7	126

*na = No TRV is available for this receptor class.

**Table E-1.1-2
Parameters for the Ecological Exposure Evaluation**

Class	Receptor	Exposure Media	Body Weight (kg)	Intake (kg/d)	Normalized Intake (kg/kg/d)
Bird	Mexican spotted owl	EGGS	0.58	0.059	0.102
Bird	Mexican spotted owl	SED	0.58	0.00118	0.00203
Bird	Mexican spotted owl	INSECTS	0.58	–*	–
Bird	Mexican spotted owl	WORM	0.58	–	–
Bird	Robin	INSECTS	0.077	0.117	1.519
Bird	Robin	SED	0.077	0.0117	0.1519
Bird	Robin	EGGS	0.077	–	–
Bird	Robin	WORM	0.077	0.117	1.519
Bird	Southwestern willow flycatcher	INSECTS	0.0127	0.010033	0.79
Bird	Southwestern willow flycatcher	SED	0.0127	–	–
Bird	Southwestern willow flycatcher	EGGS	0.0127	–	–
Bird	Southwestern willow flycatcher	WORM	0.0127	0.010033	0.79
Mammal	Bat	INSECTS	0.0088	0.0036	0.409
Mammal	Bat	SED	0.0088	–	–
Mammal	Bat	EGGS	0.0088	–	–
Mammal	Bat	WORM	0.0088	0.0036	0.409
Mammal	Fox	EGGS	3.94	0.55	0.1396
Mammal	Fox	SED	3.94	0.0165	0.00419
Mammal	Fox	INSECTS	3.94	–	–
Mammal	Fox	WORM	3.94	–	–
Mammal	Shrew	INSECTS	0.015	0.0093	0.62
Mammal	Shrew	SED	0.015	0.00093	0.062
Mammal	Shrew	EGGS	0.015	–	–
Mammal	Shrew	WORM	0.015	0.0093	0.62

* – = Exposure media are not evaluated for this receptor.

Table E-1.2-1
Number of Nest Boxes Monitored by Year in
Pajarito Canyon Watershed, Other Canyons, and Reference Locations

Watershed	Reach	1997	1998	1999	2000	2001	2002	2003	2004	2005	2006	2007	2008	Grand Total
Pajarito	AW-1	0	0	0	0	0	0	0	0	0	0	2	5	7
	PA-2W	0	0	0	0	0	0	0	0	0	2	2	4	8
	PA-3E	0	0	0	0	0	0	0	0	0	1	1	4	6
	PA-4	0	0	0	0	0	0	0	0	0	1	0	0	1
	PAS-1E	0	0	0	0	0	0	0	0	0	0	4	5	9
	PAS-2W	0	0	0	0	0	0	0	0	0	0	1	3	4
	TWSE-1W	0	0	0	0	0	0	0	0	0	0	8	9	17
	No reach	0	7	2	0	5	2	2	3	6	5	3	3	38
Other	Other Canyon	33	81	86	64	66	73	145	94	102	70	89	96	999
Reference	Reference	7	9	4	7	11	24	31	25	31	27	30	39	245
Grand Total		40	97	92	71	82	99	178	122	139	106	140	168	1334

Table E-1.2-2
Number of Active Nest Locations by Year in
Pajarito Canyon Watershed, Other Canyons, and Reference Locations

Watershed	Reach	1997	1998	1999	2000	2001	2002	2003	2004	2005	2006	2007	2008	Grand Total
Pajarito	AW-1	0	0	0	0	0	0	0	0	0	0	1	0	1
	No reach	0	0	0	0	0	0	0	0	3	0	5	1	9
	PA-3E	0	0	0	0	0	0	0	0	0	0	0	2	2
	PAS-2W	0	0	0	0	0	0	0	0	0	0	0	1	1
Other	Other Canyon	28	47	43	13	32	24	30	22	35	11	27	36	348
Reference	Reference		9		10	6	3	14	4	17	2	1	5	71
Grand Total		28	56	43	23	38	27	44	26	55	13	34	45	432

**Table E-1.2-3
Nest Box Locations**

Watershed	Canyon Segment	Group	Reach
Pajarito	Lower Pajarito	Pajarito	PA-3E
Pajarito	Lower Pajarito	Pajarito	PA-4
Pajarito	Lower Pajarito	DX	No reach
Pajarito	Lower Pajarito	TA-51	No reach
Pajarito	Upper Pajarito	Pajarito	PA-2W
Pajarito	Upper Pajarito	PJDAM	PA-2W
Pajarito	Upper Pajarito	TA-8	AW-1
Pajarito	Upper Pajarito	TA-8	PAS-1E
Pajarito	Upper Pajarito	TA-8	PAS-2W
Pajarito	Upper Pajarito	TA-14	No reach
Twomile	Twomile	TA-22	TWSE-1W
Threemile	Threemile	DX	No reach
Ref ^a	Ref	Ref	Ref
Other ^b	Not Applicable	Other	Not Applicable

^a Nest boxes at the Los Alamos Golf Course, Guaje Pines Cemetery, and Cañada del Buey are reference locations.

^b Other locations include nest boxes in Los Alamos, Pueblo, Mortandad, and Sandia watersheds.

**Table E-2.1-1
Parameters Used to Calculate Chemical Soil-Screening Levels**

Parameters	Residential Values ^a	Recreational Values ^b
		(Adult Trail User)
Target HQ	1	1
Target cancer risk	5-Oct	5-Oct
Averaging time (carcinogen)	70 yr × 365 d	70 yr × 365 d
Averaging time (noncarcinogen)	ED ^c × 365 d	ED × 365 d
Skin absorption factor	SVOC = 0.1	SVOC = 0.1
	Chemical-specific	Chemical-specific
Adherence factor–child	0.2 mg/cm ²	n/a ^d
Body weight–child	15 kg (0–6 yr-old)	n/a
Cancer slope factor–oral (chemical-specific)	mg/kg-day ⁻¹	mg/kg-day ⁻¹
Cancer slope factor–inhalation (chemical-specific)	mg/kg-day ⁻¹	mg/kg-day ⁻¹
Exposure frequency	350 d/yr	200 event/yr
Exposure duration–child	6 yr (0–6 yr-old)	n/a
Age-adjusted ingestion factor	114 mg-yr/kg-d	n/a
Age-adjusted inhalation factor	11 m ³ -yr/kg-d	n/a

Table E-2.1-1 (continued)

Parameters	Residential Values ^a	Recreational Values ^b
		(Adult Trail User)
Inhalation rate–child	10 m ³ /d	n/a
Soil ingestion rate–child	200 mg/d	n/a
Particulate emission factor	6.61 × 10 ⁹ m ³ /kg	6.61 × 10 ⁹ m ³ /kg
Reference dose–oral (chemical-specific)	mg/kg-d	mg/kg-d
Reference dose–inhalation (chemical-specific)	mg/kg-d	mg/kg-d
Exposed surface area–child	2800 cm ² /d (head, hands, forearms, lower legs, feet)	n/a
Age-adjusted skin contact factor for carcinogens	361 mg-yr/kg-d	n/a
Volatilization factor for soil (chemical-specific)	m ³ /kg	m ³ /kg
Body weight–adult	70 kg	70 kg
Exposure duration	30 yr ^e	30 yr
Adherence factor–adult	0.07 mg/cm ²	0.2 mg/cm ²
Soil ingestion rate–adult	100 mg/d	25.6 mg/event
Exposed surface area–adult	5700 cm ² /d (head, hands, forearms, lower legs)	3525 cm ² (head, hands, forearms, lower legs)
Inhalation rate–adult	20 m ³ /d	1.6 m ³ /h
Event time	n/a	1 h

^a Parameter values from NMED (2006, 092513).

^b Parameter values from LANL (2007, 094496).

^c ED = Exposure duration.

^d n/a = Not applicable.

^e Exposure duration for lifetime resident is 30 yr. For carcinogens, the exposures are combined for child (6 yr) and adult (24 yr).

Table E-2.1-2
Parameters Used in the Screening-Level Calculations for
Radionuclides, Recreational (Adult Trail User)

Parameters	Construction Worker, Adult
Inhalation rate (m ³ /yr)	14,035 ^a
Mass loading (g/m ³)	1.5 × 10 ⁻⁷ ^b
Outdoor time fraction	0.0228 ^c
Indoor time fraction	0
Soil ingestion (g/yr)	225 ^d
Surface-water ingestion	0.2 l/event
Surface-water exposure frequency	20 event/yr

^a Calculated as $[1.6 \text{ m}^3/\text{h} \times 200 \text{ h/yr}] / [\text{indoor} + \text{outdoor time fractions}]$, where 1.6 m³/h is the adult inhalation rate for moderate activity (EPA 1997, 066596, Table 5-23).

^b Calculated as $(1/6.6 \times 10^9 \text{ m}^3/\text{kg}) \times 1000 \text{ g/kg}$, where $6.6 \times 10^9 \text{ m}^3/\text{kg}$ is the particulate emission factor used for residential and industrial scenarios (NMED 2006, 092513).

^c Calculated as $(1 \text{ h/d} \times 200 \text{ d/yr}) / 8766 \text{ h/yr}$, where 1 h/d is the exposure time for a recreational adult or child (LANL 2005, 088493).

^d Calculated as $[(0.1 \text{ g/d} / 3.9 \text{ h/d}) \times 200 \text{ h/yr}] / [\text{indoor} + \text{outdoor time fractions}]$, where 3.9 h/d is the time-weighted average for “doers” across ages 12–44 (EPA 1997, 066598, Table 15-10; data are from a key activity).

**Table E-2.1-3
Parameters Used to Calculate Chemical Surface-Water Screening Levels**

Parameters	Recreational (Adult Trail User) Values ^a
Target HQ	1
Target cancer risk	5-Oct
Averaging time (carcinogen)	70 yr × 365 d
Averaging time (noncarcinogen)	ED × 365 d
Skin absorption factor	SVOC = 0.1
	Chemical-specific
Cancer slope factor–oral (chemical-specific)	mg/kg-d ⁻¹
Cancer slope factor–inhalation (chemical-specific)	mg/kg-d ⁻¹
Reference dose–oral (chemical-specific)	mg/kg-d
Reference dose–inhalation (chemical-specific)	mg/kg-d
Body weight–adult	70 kg
Surface-water Ingestion	0.2 l/event
Exposure frequency	20 event/yr
Exposure duration	30 yr
Averaging time	30 yr
Exposed surface area	2130 cm ²
Exposure time	1 h/d
Exposure frequency	20 d/yr

^a Parameter values from LANL (2004, 087390).

^b ED = Exposure duration.

**Table E-2.1-4
Parameters Used in the Screening Level Calculations for Radionuclides, Residential**

Parameters	Residential, Child	Residential, Adult
Inhalation rate (m ³ /yr)	3652.5 ^a	7305 ^b
Mass loading (g/m ³)	1.5 × 10 ^{-7c}	1.5 × 10 ^{-7c}
Outdoor time fraction	0.2236 ^d	0.0599 ^e
Indoor time fraction	0.7347 ^f	0.8984 ^g
Soil ingestion (g/yr)	73 ^h	36.5 ⁱ

^a Calculated as $[10 \text{ m}^3/\text{d} \times 350 \text{ d/yr}] / [\text{indoor} + \text{outdoor time fractions}]$, where 10 m³/d is the daily inhalation rate of a child (NMED 2006, 092513).

^b Calculated as $[20 \text{ m}^3/\text{d} \times 350 \text{ d/yr}] / [\text{indoor} + \text{outdoor time fractions}]$, where 20 m³/d is the daily inhalation rate of an adult (NMED 2006, 092513).

^c Calculated as $[1 / 6.6 \times 10^{+9} \text{ m}^3/\text{kg}] \times 1000 \text{ g/kg}$, where 6.6 × 10⁺⁹ m³/kg is the particulate emission factor (NMED 2006, 092513).

^d Calculated as $[5.6 \text{ h/d} \times 350 \text{ d/yr}] / 8766 \text{ hr/yr}$, where 5.6 h/d is an estimate of time spent outdoors for a 3–11-yr-old child (EPA 1997, 066598, Section 15.4-1).

^e Calculated as $[1.5 \text{ h/d} \times 350 \text{ d/yr}] / 8766 \text{ h/yr}$, where 1.5 h/d is an estimate of time spent outdoors for an adult 12 yr and older (EPA 1997, 066598, Section 15.4-1).

^f Calculated as $[(24 - 5.6 \text{ h/d} \times 350 \text{ d/yr}) / 8766 \text{ h/yr}]$.

^g Calculated as $[(24 - 1.5 \text{ h/d} \times 350 \text{ d/yr}) / 8766 \text{ h/yr}]$.

^h Calculated as $[0.2 \text{ g/d} \times 350 \text{ d/yr}] / [\text{indoor} + \text{outdoor time fractions}]$, where 0.2 g/d is the child soil ingestion rate (NMED 2006, 092513).

ⁱ Calculated as $[0.1 \text{ g/d} \times 350 \text{ d/yr}] / [\text{indoor} + \text{outdoor time fractions}]$, where 0.1 g/d is the adult soil ingestion rate (NMED 2006, 092513).

**Table E-2.1-5
Toxicity Values for Chemical COPCs for
Which Surface-Water Chemical Screening Values Were Calculated**

Chemical	Oral Slope Factor (mg/kg-d) ⁻¹	Reference ^a	Reference Dose Oral (mg/kg-d)	Reference
Arsenic	1.50E+00	IRIS	3.00E-04	IRIS
DDD	2.40E-01	IRIS	na ^b	na
DDE	3.40E-01	IRIS	na	na
DDT	3.40E-01	IRIS	5.00E-04	IRIS
Dieldrin	1.60E+01	IRIS	5.00E-05	IRIS
Chloroform	8.05E-02	IRIS	na	na
RDX	1.10E-01	IRIS	na	na
Trichloroethene	4.00E-01	IRIS	na	na

^a IRIS = Integrated Risk Information System.

^b na = Not available.

**Table E-2.1-6
Toxicity Values for Radionuclide COPCs for Which Surface-Water
Chemical Screening Values Were Calculated**

Chemical	DCF	Reference
	Ingestion (mrem/pCi)	
Radium-226	1.32E-03	LANL (2006, 094161)
Radium-228	1.62E-03	Health Canada (HC), 1995. "Radiological Characteristics". http://www.hc-sc.gc.ca/ewh-semt/pubs/water-eau/radiological_characteristics/index-eng.php#Application .

**Table E-2.2-1
EPCs for Sediment COPCs**

Reach	COPC	End Point	Number of Samples	Number Detects	Frequency of Detection	Maximum Detected Concentration	Mean	Standard Deviation	Distribution	95% Upper Confidence Limit ¹	Exposure Point Concentration ²
AEN-1	Aluminum	nc	10	10	100%	21000	10462.000	4555.948	normal	13103	13103
AEN-1	Arsenic	ca	10	10	100%	6.56	3.64	1.30	normal	4.39	4.39
AEN-1	Benzo[a]pyrene	ca	10	4	40%	0.511	0.0731	0.157	logNormal	0.684	0.511
AEN-1	Cadmium	nc	10	10	100%	4.74	1.80	1.43	normal	2.63	2.63
AEN-1	Iron	nc	10	10	100%	16000	10729.000	2390.437	normal	12114	12114
AEN-1	Manganese	nc	10	10	100%	779	453	137	normal	532	532
AEN-1	TATB	nc	10	5	50%	4.37	1.36	1.48	logNormal	6.70	4.37
AEN-1	Thallium	nc	10	10	100%	1.71	0.89	0.57	normal	1.23	1.23
AEN-1	Uranium (Calculated Total)	nc	10	10	100%	8.63	4.86	1.81	normal	5.91	5.91
AEN-1	Vanadium	nc	10	10	100%	43.4	22.2	9.54	normal	27.7	27.7
AES-1	Aluminum	nc	10	10	100%	20100	12613	4156	normal	15022	15022
AES-1	Arsenic	ca	10	10	100%	5.75	3.50	0.908	logNormal	4.06	4.06
AES-1	Iron	nc	10	10	100%	15300	12630	1645	normal	13583	13583
AES-1	Manganese	nc	10	10	100%	791	487	156	normal	577	577
AES-1	Vanadium	nc	10	10	100%	31.1	22.8	4.06	normal	25.1	25.1
AW-1	Aluminum	nc	21	21	100%	34600.0	14671.9	8396.0	normal	17831	17831
AW-1	Aroclor-1254	ca&nc	21	18	86%	2.63	0.224	0.575	logNormal	0.748	0.748

Table E-2.2-1 (continued)

Reach	COPC	End Point	Number of Samples	Number Detects	Frequency of Detection	Maximum Detected Concentration	Mean	Standard Deviation	Distribution	95% Upper Confidence Limit ¹	Exposure Point Concentration ²
AW-1	Aroclor-1260	ca&nc	21	15	71%	0.804	0.0777	0.178	logNormal	0.283	0.283
AW-1	Arsenic	ca	21	21	100%	20.0	7.14	4.34	logNormal	8.95	8.95
AW-1	Benzo[a]anthracene	ca	21	14	67%	0.670	0.114	0.155	logNormal	0.314	0.314
AW-1	Benzo[a]pyrene	ca	21	13	62%	0.707	0.131	0.168	nonpar	0.360	0.360
AW-1	Benzo[b]fluoranthene	ca	21	8	38%	1.00	0.184	0.232	nonpar	0.404	0.404
AW-1	Iron	nc	21	21	100%	24700	14030	3781	normal	15453	15453
AW-1	Lead	nc	21	21	100%	77.2	32.3	17.1	normal	38.8	38.8
AW-1	Manganese	nc	21	21	100%	691	393	166	normal	455	455
AW-1	Silver	nc	21	21	100%	55.10	29.14	16.94	normal	35.5	35.5
AW-1	Uranium (Calculated Total)	nc	10	10	100%	10.2	3.97	2.32	logNormal	5.36	5.36
AW-1	Vanadium	nc	21	21	100%	86.1	37.0	15.5	logNormal	44.0	44.0
PA-0	Cesium-137	rad	11	11	100%	4.92	1.09	1.37	logNormal	3.16	3.16
PA-0	Plutonium-239/240	rad	11	7	64%	3.75	0.388	1.12	logNormal	34.0	3.75
PA-1E	Arsenic	ca	14	14	100%	4.30	2.51	0.800	normal	2.89	2.89
PA-2W	Aluminum	nc	18	18	100%	20700	7728	4336	logNormal	9953	9953
PA-2W	Iron	nc	18	18	100%	16000	10334	2620	normal	11409	11409
PA-2W	Manganese	nc	18	18	100%	653	421	157	normal	486	486
PA-2W	Uranium (Calculated Total)	nc	18	18	100%	9.23	4.67	1.84	normal	5.43	5.43

Table E-2.2-1 (continued)

Reach	COPC	End Point	Number of Samples	Number Detects	Frequency of Detection	Maximum Detected Concentration	Mean	Standard Deviation	Distribution	95% Upper Confidence Limit ¹	Exposure Point Concentration ²
PA-2W	Vanadium	nc	18	17	94%	26.0	15.7	5.27	normal	17.9	17.9
PA-3E	Aluminum	nc	12	12	100%	16700	9209	4399	normal	11490	11490
PA-3E	Lead	nc	12	12	100%	72.800	23.499	16.758	logNormal	33.974	33.974
PA-3E	Manganese	nc	12	12	100%	1460	545	372	nonpar	1013	1013
PA-3E	Vanadium	nc	12	12	100%	20.8	14.8	4.26	normal	17.0	17.0
PA-4	Aluminum	nc	14	14	100%	32300	13314	8946	normal	17548	17548
PA-4	Arsenic	ca	14	13	93%	7.50	3.41	1.81	normal	4.27	4.27
PA-4	Benzo[a]pyrene	ca	11	3	27%	0.138	0.0314	0.0462	nonpar	0.119	0.119
PA-4	Cesium-137	rad	13	10	77%	4.18	0.857	1.33	logNormal	5.37	4.18
PA-4	Iron	nc	14	14	100%	23600	14754	5815	normal	17506	17506
PA-4	Lead	nc	14	14	100%	48.3	17.8	12.7	logNormal	26.8	26.8
PA-4	Manganese	nc	14	14	100%	2310	699	681	logNormal	1572	1572
PA-4	Thorium-228	rad	10	10	100%	2.37	1.65	0.295	logNormal	1.82	1.82
PA-4	Vanadium	nc	14	14	100%	36.1	20.6	8.56	normal	24.6	24.6
PA-5W	Aluminum	nc	10	10	100%	34700	10381	9238	logNormal	19386	19386
PA-5W	Arsenic	ca	10	10	100%	5.79	2.21	1.42	logNormal	3.44	3.44
PA-5W	Benzo[a]pyrene	ca	10	1	10%	0.0912	0.0102	0.0285	nonpar	0.0912	0.0912
PA-5W	Iron	nc	10	10	100%	23900	11310	4942	logNormal	14427	14427
PA-5W	Manganese	nc	10	10	100%	1260	387	311	nonpar	817	817

Table E-2.2-1 (continued)

Reach	COPC	End Point	Number of Samples	Number Detects	Frequency of Detection	Maximum Detected Concentration	Mean	Standard Deviation	Distribution	95% Upper Confidence Limit ¹	Exposure Point Concentration ²
PA-5W	Vanadium	nc	10	10	100%	39.8	16.7	9.38	logNormal	24.0	24.0
PAS-1E	Aluminum	nc	10	10	100%	17900	11493	3879	normal	13742	13742
PAS-1E	Arsenic	ca	10	10	100%	7.68	3.41	1.61	nonpar	5.62	5.62
PAS-1E	Iron	nc	10	10	100%	23000	15127	3940	normal	17411	17411
PAS-1E	Manganese	nc	10	10	100%	829	444	162	normal	538	538
PAS-1E	Silver	nc	10	10	100%	44.9	20.6	16.7	logNormal	57.0	44.9
PAS-1E	Vanadium	nc	10	10	100%	41.3	24.8	8.17	normal	29.5	29.5
PAS-2W	Arsenic	ca	10	10	100%	4.16	3.42	0.47	normal	3.69	3.69
PAS-2W	Benzo[a]pyrene	ca	10	6	60%	0.209	0.070	0.063	logNormal	0.187	0.187
TH-1C	Arsenic	ca	10	9	90%	4.28	2.19	1.06	normal	2.81	2.81
TH-1C	Iron	nc	10	10	100%	19300	11862	4199	normal	14296	14296
TH-1C	Manganese	nc	10	10	100%	1860	426	519	nonpar	1141	1141
TH-1C	Uranium (Calculated Total)	nc	10	10	100%	14.4	7.88	4.17	normal	10.3	10.3
TH-1E	Aluminum	nc	10	10	100%	28600.0	16166.0	6721.4	normal	20062	20062
TH-1E	Arsenic	ca	10	10	100%	7.44	3.65	1.65	normal	4.61	4.61
TH-1E	Iron	nc	10	10	100%	23000	14470	4635	normal	17157	17157
TH-1E	Manganese	nc	10	10	100%	1500	447	389	logNormal	772	772
TH-1E	Uranium (Calculated Total)	nc	10	10	100%	19.7	9.35	6.08	logNormal	15.7	15.7
TH-1E	Vanadium	nc	10	10	100%	35.20	21.70	8.69	normal	26.7	26.7

Table E-2.2-1 (continued)

Reach	COPC	End Point	Number of Samples	Number Detects	Frequency of Detection	Maximum Detected Concentration	Mean	Standard Deviation	Distribution	95% Upper Confidence Limit ¹	Exposure Point Concentration ²
TH-3	Uranium (Calculated Total)	nc	6	6	100%	27.38	14.52	7.22	normal	20.46	20.46
THM-1	Iron	nc	10	10	100%	14100	11138	2647	normal	12673	12673
THM-1	Lead	nc	10	10	100%	84.6	26.6	29.2	logNormal	61.8	61.8
THM-1	Uranium (Calculated Total)	nc	10	10	100%	153	34.2	44.4	logNormal	142	142
THS-1E	Iron	nc	10	10	100%	15900	11688	3839	normal	13913	13913
THS-1E	Thorium-228	rad	10	10	100%	3.03	1.66	0.546	logNormal	1.99	1.99
THS-1E	Thorium-232	rad	10	10	100%	2.57	1.46	0.439	logNormal	1.73	1.73
THS-1E	Uranium (Calculated Total)	nc	10	10	100%	60.4	22.5	19.1	logNormal	54.0	54.0
THS-1E	Uranium-238	rad	10	10	100%	20.3	7.6	6.4	logNormal	18.1	18.1
THS-1W	Uranium (Calculated Total)	nc	10	10	100%	138	44.2	43.8	normal	69.6	69.6
THW-1	Aluminum	nc	10	10	100%	18700	13301	3459	normal	15306	15306
THW-1	Arsenic	ca	10	10	100%	4.31	2.84	0.798	normal	3.30	3.30
THW-1	Manganese	nc	10	10	100%	546	355	106	normal	416	416
THW-1	Uranium (Calculated Total)	nc	10	10	100%	23.8	11.0	6.36	normal	14.7	14.7
THW-1	Vanadium	nc	10	10	100%	26.9	17.5	5.38	normal	20.6	20.6
TW-2E	Aroclor-1248	nc	18	3	17%	0.304	0.0334	0.0807	nonpar	0.152	0.152
TW-2E	Iron	nc	18	18	100%	24600	10588	3919	nonpar	14614	14614
TW-2E	Manganese	nc	18	18	100%	606	347	97.3	logNormal	386	386
TW-2E	Vanadium	nc	18	17	94%	23.3	13.1	3.98	normal	14.7	14.7

Table E-2.2-1 (continued)

Reach	COPC	End Point	Number of Samples	Number Detects	Frequency of Detection	Maximum Detected Concentration	Mean	Standard Deviation	Distribution	95% Upper Confidence Limit ¹	Exposure Point Concentration ²
TW-3E	Arsenic	ca	10	10	100%	6.15	3.22	1.31	normal	3.98	3.98
TW-3E	Benzo[a]pyrene	ca	10	4	40%	0.149	0.0440	0.0484	nonpar	0.140	0.140
TWN-1E	Benzo[a]anthracene	ca	12	9	75%	39.4	3.55	11.3	logNormal	1146	39.4
TWN-1E	Benzo[a]pyrene	ca	12	10	83%	26.5	2.46	7.58	logNormal	352	26.5
TWN-1E	Benzo[b]fluoranthene	ca	12	6	50%	0.778	0.255	0.301	logNormal	1.19	0.778
TWN-1E	Manganese	nc	12	12	100%	1020	395	240	logNormal	575	575
TWN-1E	Naphthalene	nc	12	1	8%	42.7	3.59	12.3	nonpar	42.7	42.7
TWN-1W	Arsenic	ca	10	10	100%	4.39	2.77	1.16	normal	3.45	3.45
TWSE-1E	Aluminum	nc	11	11	100%	17800	6869	4900	logNormal	11056	11056
TWSE-1E	Arsenic	ca	11	11	100%	4.18	2.51	1.01	normal	3.06	3.06
TWSE-1E	Iron	nc	11	11	100%	17600	10556	3410	normal	12420	12420
TWSE-1E	Manganese	nc	11	11	100%	1200	423	289	logNormal	660	660
TWSE-1E	Vanadium	nc	11	11	100%	25.4	14.0	6.28	normal	17.5	17.5
TWSE-1W	Aluminum	nc	10	10	100%	20400	14263	4190	normal	16692	16692
TWSE-1W	Arsenic	ca	10	10	100%	6.00	3.20	1.16	logNormal	3.95	3.95
TWSE-1W	Iron	nc	10	10	100%	17100	12797	3395	normal	14765	14765
TWSE-1W	Vanadium	nc	10	10	100%	36.6	24.6	7.5	normal	29.0	29.0
TWSW-1E	Aluminum	nc	12	12	100%	16300	7394	4335	normal	9641	9641
TWSW-1E	Arsenic	ca	12	11	92%	4.75	3.26	0.77	normal	3.66	3.66

Table E-2.2-1 (continued)

Reach	COPC	End Point	Number of Samples	Number Detects	Frequency of Detection	Maximum Detected Concentration	Mean	Standard Deviation	Distribution	95% Upper Confidence Limit ¹	Exposure Point Concentration ²
TWSW-1E	Manganese	nc	12	12	100%	1460	484	390	logNormal	918	918
TWSW-1E	Uranium (Calculated Total)	nc	12	12	100%	11.2	4.55	2.78	logNormal	6.43	6.43
TWSW-1E	Vanadium	nc	12	12	100%	22.3	16.5	5.34	nonpar	23.2	22.3
TWSW-1W	Aluminum	nc	10	10	100%	20800	12438	6826	normal	16395	16395
TWSW-1W	Arsenic	ca	10	10	100%	5.36	3.96	1.01	normal	4.54	4.54
TWSW-1W	Iron	nc	10	10	100%	17200	11246	4124	normal	13636	13636
TWSW-1W	Vanadium	nc	10	10	100%	31.3	20.4	7.26	normal	24.6	24.6

Notes: The following abbreviations are used in this table: ca = carcinogen, nc = noncarcinogen, rad = radionuclide. Units of concentration for metals and organics are mg/kg; for radionuclides, pCi/kg (picocuries per kilogram).

**Table E-2.3-1
EPCs for Surface Water COPCs**

Location	COPC	End Point	Number of Samples	Number Detects	Frequency of Detection	Maximum Detected Concentration	Mean	Standard Deviation	Distribution	95% Upper Confidence Limit ^a	Exposure Point Concentration ^b
Anderson Spring	Aluminum	nc	14	10	71%	9200	2575	2765	logNormal	36167	9200
Anderson Spring	Ammonia as Nitrogen	nc	8	3	38%	115	32.9	36.7	logNormal	119	115
Anderson Spring	Arsenic	ca	14	2	14%	2.60	1.87	0.878	none	2.60	2.6
Anderson Spring	Chloroform	ca	7	5	71%	0.405	0.370	0.0255	normal	0.389	0.389
Anderson Spring	Fluoride	nc	9	9	100%	346	265	45.5	normal	293	293
Anderson Spring	Iron	nc	14	13	93%	5230	1416	1548	neither	5532	5230
Anderson Spring	Lead	nc	14	8	57%	3.40	1.50	1.12	logNormal	2.56	2.56
Anderson Spring	Thallium	nc	14	3	21%	0.560	0.335	0.107	normal	0.385	0.385
Bulldog Spring	Aluminum	nc	19	19	100%	9940	2819	3173	logNormal	6596	6596
Bulldog Spring	Ammonia as Nitrogen	nc	11	2	18%	83.0	21.8	23.3	none	41.4	41.40
Bulldog Spring	Arsenic	ca	19	1	5%	1.60	1.99	0.926	none	1.60	1.60
Bulldog Spring	Chloride	nc	12	12	100%	27500	17183	4971	neither	23439	23438
Bulldog Spring	DDD[4,4'-]	ca	10	1	10%	0.0233	0.0213	0.000877	none	0.0233	0.023
Bulldog Spring	DDE[4,4'-]	ca	10	1	10%	0.0220	0.0211	0.000589	none	0.0220	0.022
Bulldog Spring	DDT[4,4'-]	ca	10	1	10%	0.0173	0.0207	0.00128	none	0.0173	0.017
Bulldog Spring	Dieldrin	ca	10	1	10%	0.00767	0.0197	0.00425	none	0.00767	0.008
Bulldog Spring	Fluoride	nc	12	12	100%	338	259	54.0	normal	287	287

Table E-2.3-1 (continued)

Location	COPC	End Point	Number of Samples	Number Detects	Frequency of Detection	Maximum Detected Concentration	Mean	Standard Deviation	Distribution	95% Upper Confidence Limit ^a	Exposure Point Concentration ^b
Bulldog Spring	Iron	nc	19	19	100%	5120	1395	1608	logNormal	3381	3380
Bulldog Spring	Lead	nc	19	10	53%	3.30	0.985	1.03	logNormal	2.85	2.85
Bulldog Spring	RDX	ca	10	10	100%	6.42	3.32	1.69	normal	4.30	4.29
Bulldog Spring	Thallium	nc	19	3	16%	0.620	0.270	0.117	logNormal	0.322	0.322
Bulldog Spring	Trichloroethene	ca	9	1	11%	0.351	0.483	0.050	none	0.351	0.351
Charlie's Spring	Aluminum	nc	14	14	100%	12700	3074	3919	logNormal	12614	12614
Charlie's Spring	Arsenic	ca	14	3	21%	2.30	1.35	0.49	normal	1.58	1.58
Charlie's Spring	Chloride	nc	9	9	100%	25600	14861	8119	normal	19893	19893
Charlie's Spring	Iron	nc	14	14	100%	6070	1487	1919	logNormal	6841	6070
Charlie's Spring	Lead	nc	14	7	50%	4.50	1.14	1.27	logNormal	2.68	2.67
Charlie's Spring	Mercury	nc	14	1	7%	0.120	0.052	0.041	none	0.120	0.120
Charlie's Spring	Thallium	nc	14	1	7%	0.590	0.303	0.169	none	0.590	0.590
Homestead Spring	Aluminum	nc	19	19	100%	11400	3635	3589	logNormal	8968	8968
Homestead Spring	Ammonia as Nitrogen	nc	11	2	18%	174	40.5	56.4	none	47.0	47.0
Homestead Spring	Arsenic	ca	19	5	26%	5.00	2.08	0.914	logNormal	2.48	2.48
Homestead Spring	Iron	nc	19	19	100%	6090	1799	1923	logNormal	4960	4959
Homestead Spring	Lead	nc	19	12	63%	4.50	1.28	1.27	logNormal	2.63	2.63
Homestead Spring	Mercury	nc	19	1	5%	0.370	0.066	0.082	none	0.370	0.370
Homestead Spring	Radium-226	rad	2	2	100%	2.72	2.02	1.00	none	NA	2.72

Table E-2.3-1 (continued)

Location	COPC	End Point	Number of Samples	Number Detects	Frequency of Detection	Maximum Detected Concentration	Mean	Standard Deviation	Distribution	95% Upper Confidence Limit ^a	Exposure Point Concentration ^b
Homestead Spring	Radium-228	rad	1	1	100%	3.13	3.13	NA	none	NA	3.13
Homestead Spring	Thallium	nc	19	2	11%	0.680	0.319	0.164	none	0.680	0.680
Kieling Spring	Aluminum	nc	19	19	100%	13900	4471	4924	logNormal	30640	13900
Kieling Spring	Ammonia as Nitrogen	nc	11	1	9%	51.5	15.6	14.2	none	51.5	51.50
Kieling Spring	Arsenic	ca	19	3	16%	7.60	1.33	1.62	logNormal	1.91	1.90
Kieling Spring	Chloride	nc	12	12	100%	27500	15089	6728	normal	18577	18577
Kieling Spring	Iron	nc	19	18	95%	6920	2237	2542	logNormal	10955	6920
Kieling Spring	Lead	nc	19	11	58%	6.00	1.54	1.75	logNormal	3.51	3.50
Kieling Spring	Mercury	nc	19	4	21%	0.560	0.055	0.124	logNormal	0.103	0.103
Kieling Spring	Thallium	nc	19	2	11%	0.560	0.283	0.161	none	0.560	0.560
La Delfe above Pajarito	Aluminum	nc	4	4	100%	6680	2441	2884	normal	5834	5833
La Delfe above Pajarito	Arsenic	ca	4	1	25%	3.10	2.54	0.985	none	3.10	3.100
La Delfe above Pajarito	Iron	nc	4	4	100%	3220	1192	1380	normal	2816	2816
La Delfe above Pajarito	Lead	nc	4	2	50%	2.10	0.720	0.920	none	2.10	2.10
La Delfe above Pajarito	RDX	ca	3	2	67%	1.50	1.11	0.619	none	1.50	1.50
La Delfe above Pajarito	Thallium	nc	4	1	25%	0.470	0.236	0.167	none	0.470	0.470
Pajarito 0.5 mi above SR-501	Aluminum	nc	19	18	95%	5910	1500	1717	logNormal	6025	5910

Table E-2.3-1 (continued)

Location	COPC	End Point	Number of Samples	Number Detects	Frequency of Detection	Maximum Detected Concentration	Mean	Standard Deviation	Distribution	95% Upper Confidence Limit ^a	Exposure Point Concentration ^b
Pajarito 0.5 mi above SR-501	Ammonia as Nitrogen	nc	9	4	44%	141	64.1	48.4	neither	134	134.3
Pajarito 0.5 mi above SR-501	Arsenic	ca	19	2	11%	2.00	2.13	0.909	none	2.00	2.0
Pajarito 0.5 mi above SR-501	Iron	nc	19	16	84%	3000	655	813	logNormal	2686	2686
Pajarito 0.5 mi above SR-501	Lead	nc	19	7	37%	2.10	0.617	0.482	logNormal	0.890	0.890
Pajarito 0.5 mi above SR-501	Thallium	nc	19	3	16%	0.620	0.271	0.130	logNormal	0.333	0.333
Pajarito above SR-4	Arsenic	ca	3	1	33%	3.90	3.30	0.520	none	3.90	3.90
Pajarito above SR-4	Thallium	nc	3	1	33%	0.500	0.300	0.173	none	0.500	0.500
Pajarito above Starmers	Arsenic	ca	4	1	25%	2.30	2.28	1.02	none	2.30	2.30
Pajarito above Starmers	Manganese	nc	4	4	100%	276	102	117	logNormal	28075	276
Pajarito above TA-18	Aluminum	nc	3	3	100%	6670	3346	3000	none	14163	6670
Pajarito above TA-18	Iron	nc	3	3	100%	3610	1832	1637	none	7735	3610
Pajarito above TA-18	Lead	nc	3	3	100%	2.50	1.71	1.23	none	6.14	2.500
Pajarito above Threemile	Aluminum	nc	3	3	100%	7040	3076	3561	none	15915	7040
Pajarito above Threemile	Iron	nc	3	3	100%	3560	1582	1786	none	8022	3560
Pajarito above Threemile	Lead	nc	3	3	100%	2.90	1.48	1.31	none	6.20	2.900
Pajarito above Twomile	Aluminum	nc	19	19	100%	7400	2844	1987	normal	3634	3634

Table E-2.3-1 (continued)

Location	COPC	End Point	Number of Samples	Number Detects	Frequency of Detection	Maximum Detected Concentration	Mean	Standard Deviation	Distribution	95% Upper Confidence Limit ^a	Exposure Point Concentration ^b
Pajarito above Twomile	Ammonia as Nitrogen	nc	8	6	75%	74.0	38.2	18.7	normal	50.7	50.7
Pajarito above Twomile	Arsenic	ca	19	1	5%	1.60	1.63	0.902	none	1.60	1.60
Pajarito above Twomile	Chloride	nc	8	8	100%	26600	14255	6352	normal	18510	18509
Pajarito above Twomile	Fluoride	nc	8	8	100%	222	154	34.0	normal	177	176
Pajarito above Twomile	Iron	nc	19	19	100%	3570	1355	942	normal	1730	1729
Pajarito above Twomile	Lead	nc	19	14	74%	2.30	0.965	0.475	logNormal	1.20	1.202
Pajarito above Twomile	Thallium	nc	19	3	16%	0.850	0.228	0.195	logNormal	0.338	0.338
Pajarito at Rio Grande	Fluoride	nc	3	3	100%	471	423	75.2	none	612	471
Pajarito at Rio Grande	Thallium	nc	4	1	25%	0.460	0.174	0.210	none	0.460	0.460
Pajarito below confluences of South and North Anchor East Basin	Aluminum	nc	14	14	100%	11100	2777	3478	logNormal	9143	9143
Pajarito below confluences of South and North Anchor East Basin	Ammonia as Nitrogen	nc	7	4	57%	102	41.4	30.5	normal	63.8	63
Pajarito below confluences of South and North Anchor East Basin	Arsenic	ca	14	2	14%	2.30	2.06	0.94	none	2.30	2.30

Table E-2.3-1 (continued)

Location	COPC	End Point	Number of Samples	Number Detects	Frequency of Detection	Maximum Detected Concentration	Mean	Standard Deviation	Distribution	95% Upper Confidence Limit ^a	Exposure Point Concentration ^b
Pajarito below confluences of South and North Anchor East Basin	Iron	nc	14	14	100%	5760	1423	1850	logNormal	4932	4931
Pajarito below confluences of South and North Anchor East Basin	Lead	nc	14	7	50%	4.00	0.99	1.32	logNormal	3.90	3.89
Pajarito below confluences of South and North Anchor East Basin	RDX	ca	5	5	100%	0.833	0.489	0.236	normal	0.714	0.714
Pajarito below confluences of South and North Anchor East Basin	Thallium	nc	14	2	14%	0.530	0.324	0.157	none	0.530	0.530
PC Spring	Aluminum	nc	19	19	100%	3750	971	982	logNormal	2165	2165
PC Spring	Ammonia as Nitrogen	nc	11	1	9%	190	33.6	55.8	none	190	190
PC Spring	Arsenic	ca	19	5	26%	2.40	1.57	0.336	normal	1.71	1.70
PC Spring	Thallium	nc	19	2	11%	0.560	0.297	0.174	none	0.520	0.520
Spring 4	Arsenic	ca	12	6	50%	5.50	3.45	1.45	logNormal	4.49	4.48
Spring 4	Benzo(b)fluoranthene	ca	6	1	17%	7.20	1.66	2.72	none	7.20	7.20
Spring 4	Benzo(k)fluoranthene	ca	6	1	17%	0.500	0.541	0.053	none	0.500	0.500

Table E-2.3-1 (continued)

Location	COPC	End Point	Number of Samples	Number Detects	Frequency of Detection	Maximum Detected Concentration	Mean	Standard Deviation	Distribution	95% Upper Confidence Limit ^a	Exposure Point Concentration ^b
Spring 4	Fluoride	nc	8	6	75%	481	443	38.2	normal	469	468
Spring 4A	Arsenic	ca	12	5	42%	4.30	3.45	0.716	normal	3.82	3.81
Spring 4A	Fluoride	nc	9	7	78%	535	412	80.6	normal	462	461
Spring 4A	Thallium	nc	12	1	8%	0.430	0.283	0.132	none	0.430	0.430
Spring 4AA	Arsenic	ca	8	4	50%	4.50	3.81	0.567	normal	4.19	4.19
Spring 4AA	Fluoride	nc	7	7	100%	532	502	18.0	normal	515	515
Spring 4AA	Thallium	nc	8	1	13%	0.320	0.240	0.117	none	0.320	0.320
Spring 4B	Arsenic	ca	8	4	50%	4.50	2.66	1.05	normal	3.36	3.36
Spring 4B	Fluoride	nc	7	5	71%	510	463	27.3	normal	483	483
Spring 4B	Mercury	nc	8	1	13%	0.870	0.152	0.292	none	0.870	0.870
Spring 4B	Thallium	nc	8	1	13%	0.470	0.296	0.162	none	0.470	0.470
Spring 4C	Arsenic	ca	8	4	50%	6.10	3.09	1.43	normal	4.05	4.04
Spring 4C	Fluoride	nc	7	7	100%	491	473	16.0	normal	485	485
Starmer Spring	Aluminum	nc	19	19	100%	10800	2888	3000	logNormal	7212	7212
Starmer Spring	Ammonia as Nitrogen	nc	10	1	10%	86.0	21.1	24.4	none	86.0	86.0
Starmer Spring	Arsenic	ca	19	2	11%	2.00	1.93	0.920	none	2.00	2.00
Starmer Spring	Iron	nc	19	19	100%	5610	1415	1562	logNormal	3714	3714
Starmer Spring	Lead	nc	19	10	53%	3.70	1.08	1.08	logNormal	2.37	2.36
Starmer Spring	Thallium	nc	19	1	5%	0.590	0.288	0.169	none	0.590	0.590

Table E-2.3-1 (continued)

Location	COPC	End Point	Number of Samples	Number Detects	Frequency of Detection	Maximum Detected Concentration	Mean	Standard Deviation	Distribution	95% Upper Confidence Limit ^a	Exposure Point Concentration ^b
Starmers above Pajarito	Aluminum	nc	4	4	100%	5480	2180	2247	normal	4823	4823
Starmers above Pajarito	Arsenic	ca	4	1	25%	3.00	2.46	1.08	none	3.00	3.00
Starmers above Pajarito	Iron	nc	4	4	100%	2600	1030	1064	normal	2282	2282
Starmers above Pajarito	Lead	nc	4	2	50%	1.60	0.593	0.672	none	1.60	1.60
Starmers above Pajarito	Mercury	nc	5	1	20%	0.0760	0.0344	0.0233	none	0.0760	0.076
TA-18 Spring	Aluminum	nc	13	9	69%	4420	762	1373	logNormal	6259	4420
TA-18 Spring	Iron	nc	13	13	100%	3790	1922	907	normal	2370	2370
TA-18 Spring	Manganese	nc	13	13	100%	302	125	64.4	logNormal	170	170
TA-18 Spring	Sulfate	nc	7	7	100%	37100	15103	9921	logNormal	24576	24576
TA-18 Spring	Thallium	nc	13	2	15%	0.490	0.301	0.136	none	0.450	0.450
Threemile Spring	Thallium	nc	4	1	25%	0.430	0.258	0.115	none	0.430	0.430
TW-1.72 Spring	Aluminum	nc	4	4	100%	9090	5903	2966	normal	9392	9090
TW-1.72 Spring	Antimony	nc	4	2	50%	4.90	2.55	2.49	none	4.90	4.900
TW-1.72 Spring	Arsenic	ca	4	1	25%	1.50	2.06	1.13	none	1.50	1.50
TW-1.72 Spring	Chloride	nc	3	3	100%	93500	49833	37817	none	145004	93500
TW-1.72 Spring	Fluoride	nc	3	3	100%	237	221	13.8	none	256	237
TW-1.72 Spring	Iron	nc	4	4	100%	4720	3048	1492	normal	4803	4720
TW-1.72 Spring	Lead	nc	4	4	100%	2.70	1.76	0.806	normal	2.71	2.70
Two Mile below TA-59	Aluminum	nc	12	12	100%	10700	3505	3534	normal	5337	5336

Table E-2.3-1 (continued)

Location	COPC	End Point	Number of Samples	Number Detects	Frequency of Detection	Maximum Detected Concentration	Mean	Standard Deviation	Distribution	95% Upper Confidence Limit ^a	Exposure Point Concentration ^b
Two Mile below TA-59	Ammonia as Nitrogen	nc	7	5	71%	1960	503	826	logNormal	4033231	1960
Two Mile below TA-59	Arsenic	ca	12	4	33%	2.60	1.76	0.40	normal	1.96	1.96
Two Mile below TA-59	Chloride	nc	7	7	100%	164000	86243	53488	normal	125528	125527
Two Mile below TA-59	Fluoride	nc	7	7	100%	286	230	37.1	normal	257	256
Two Mile below TA-59	Iron	nc	12	12	100%	6120	1965	1994	logNormal	14094	6120
Two Mile below TA-59	Lead	nc	12	7	58%	4.40	1.55	1.21	normal	2.18	2.18
Two Mile below TA-59	Thallium	nc	12	2	17%	0.500	0.354	0.147	none	0.500	0.500

Note: The following abbreviations are used in this table: ca = carcinogen, nc = noncarcinogen. Units of concentration for metals and organics are ug/L (micrograms per liter); for radionuclides pCi/L (picocuries per liter).

^a Calculated based upon distribution.

^b Lesser of maximum detected value or 95% upper confidence limit.

**Table E-2.4-1
Screening Levels for the Residential Scenario**

Medium	COPC	CAS ID	Units	End Point	Target Adverse-Effect Level	Residential MSSL	Reference
Sediment	Aluminum	7429-90-5	mg/kg	nc	HQ=1	77800	NMED (2006, 092513)
Sediment	Aroclor-1248	12672-29-6	mg/kg	nc	HQ=1	1.12	NMED (2006, 092513)
Sediment	Aroclor-1254	11097-69-1	mg/kg	nc	HQ=1	1.12	NMED (2006, 092513)
Sediment	Aroclor-1254	11097-69-1	mg/kg	ca	risk=10-5	2.2	EPA (2007, 101002)
Sediment	Aroclor-1260	11096-82-5	mg/kg	nc	HQ=1	1.12	NMED (2006, 092513)
Sediment	Aroclor-1260	11096-82-5	mg/kg	ca	risk=10-5	2.2	EPA (2007, 101002)
Sediment	Arsenic	7440-38-2	mg/kg	ca	risk=10-5	3.9	NMED (2006, 092513)
Sediment	Benzo(a)anthracene	56-55-3	mg/kg	ca	risk=10-5	6.21	NMED (2006, 092513)
Sediment	Benzo(a)pyrene	50-32-8	mg/kg	ca	risk=10-5	0.621	NMED (2006, 092513)
Sediment	Benzo(b)fluoranthene	205-99-2	mg/kg	ca	risk=10-5	6.21	NMED (2006, 092513)
Sediment	Cadmium	7440-43-9	mg/kg	nc	HQ=1	39	NMED (2006, 092513)
Sediment	Cesium-137	10045-97-3	pCi/kg	rad	15 mrem/yr	5.6	LANL (2005, 088493)
Sediment	Iron	7439-89-6	mg/kg	nc	HQ=1	23500	NMED (2006, 092513)
Sediment	Lead	7439-92-1	mg/kg	nc	HQ=1	400	NMED (2006, 092513)
Sediment	Manganese	7439-96-5	mg/kg	nc	HQ=1	3590	NMED (2006, 092513)
Sediment	Naphthalene	91-20-3	mg/kg	nc	HQ=1	79.5	NMED (2006, 092513)
Sediment	Plutonium-239/240	15117-48-3	pCi/kg	rad	15 mrem/yr	33	LANL (2005, 088493)
Sediment	Silver	7440-22-4	mg/kg	nc	HQ=1	391	NMED (2006, 092513)
Sediment	TATB	3058-38-6	mg/kg	nc	HQ=1	30.6	NMED (2006, 092513) TNT Surrogate
Sediment	Thallium	7440-28-0	mg/kg	nc	HQ=1	5.16	NMED (2006, 092513)
Sediment	Thorium-228	14274-82-9	pCi/kg	rad	15 mrem/yr	2.3	LANL (2005, 088493)
Sediment	Thorium-232	7440-29-1	pCi/kg	rad	15 mrem/yr	5	LANL (2005, 088493)
Sediment	Uranium (Calculated Total)	7440-61-1	mg/kg	nc	HQ=1	230	EPA Region 9 (http://www.epa.gov/region09/waste/sfund/prg/files/04prgtable.pdf)
Sediment	Uranium-238	13981-16-3	pCi/kg	rad	15 mrem/yr	86	LANL (2005, 088493)
Sediment	Vanadium	7440-62-2	mg/kg	nc	HQ=1	78.2	NMED (2006, 092513)

Note: The following abbreviations are used in this table: MSSL = medium-specific screening level, nc = noncarcinogen, ca = carcinogen, and rad = radionuclide.

**Table E.2.4-2
Summary of Residential Risk Assessment Results**

Reach	Carcinogenic ILCR	Noncarcinogenic Hazard Index	Total Radionuclide Dose
AEN-1	2E-05	2.0	-*
AES-1	1E-05	1.3	-
AW-1	3E-05	3.0	-
PA-0	-	-	10
PA-1E	7E-06	-	-
PA-2W	-	1.3	-
PA-3E	-	0.7	-
PA-4	1E-05	1.8	23
PA-5W	1E-05	1.4	-
PAS-1E	1E-05	1.6	-
PAS-2W	1E-05	-	-
TH-1C	7E-06	1.6	-
TH-1E	1E-05	2.5	-
TH-3	-	1.3	-
THM-1	-	9.6	-
THS-1E	-	4.0	21
THS-1W	-	4.4	-
THW-1	8E-06	1.5	-
TW-2E	-	1.1	-
TW-3E	1E-05	-	-
TWN-1E	5E-04	0.7	-
TWN-1W	9E-06	-	-
TWSE-1E	8E-06	1.1	-
TWSE-1W	1E-05	1.2	-
TWSW-1E	9E-06	1.1	-
TWSW-1W	1E-05	1.1	-

Note: ICLR = Incremental lifetime cancer risk.

* = Incomplete pathway.

**Table E-2.4-3
Risk Ratios Based on EPCs for Sediment, Residential Scenario**

Carcinogens

Reach	Arsenic	Aroclor-1254 (1)	Aroclor-1260 (1)	Benzo[a]anthracene	Benzo[a]pyrene	Benzo[b]fluoranthene	Total Risk Ratio	Total Risk
Residential SSL (mg/kg)	3.9	2.2	2.2	6.21	0.621	6.21		
AEN-1	1.1	-*	-	-	0.82	-	1.9	2E-05
AES-1	1.0	-	-	-	-	-	1.0	1E-05
AW-1	2.3	0.34	0.13	0.05	0.58	0.07	3.5	3E-05
PA-0	-	-	-	-	-	-	-	-
PA-1E	0.74	-	-	-	-	-	0.74	7E-06
PA-2W	-	-	-	-	-	-	-	-
PA-3E	-	-	-	-	-	-	-	-
PA-4	1.1	-	-	-	0.19	-	1.3	1E-05
PA-5W	0.88	-	-	-	0.15	-	1.0	1E-05
PAS-1E	1.4	-	-	-	-	-	1.4	1E-05
PAS-2W	0.95	-	-	-	0.30	-	1.2	1E-05
TH-1C	0.72	-	-	-	-	-	0.72	7E-06
TH-1E	1.2	-	-	-	-	-	1.2	1E-05
TH-3	-	-	-	-	-	-	-	-
THM-1	-	-	-	-	-	-	-	-
THS-1E	-	-	-	-	-	-	-	-
THS-1W	-	-	-	-	-	-	-	-
THW-1	0.85	-	-	-	-	-	0.85	8E-06
TW-2E	-	-	-	-	-	-	-	-
TW-3E	1.0	-	-	-	0.22	-	1.2	1E-05
TWN-1E	-	-	-	6.3	43	0.13	49	5E-04
TWN-1W	0.88	-	-	-	-	-	0.88	9E-06
TWSE-1E	0.79	-	-	-	-	-	0.79	8E-06
TWSE-1W	1.0	-	-	-	-	-	1.0	1E-05
TWSW-1E	0.94	-	-	-	-	-	0.94	9E-06
TWSW-1W	1.2	-	-	-	-	-	1.2	1E-05

Notes: Residential SSLs are from NMED 2006, unless otherwise noted. All values from EPA Region 6 Human Health Medium-Specific Screening Levels (HHMSSLs) adjusted to TR 10⁻⁵. Bold/shaded cells: risk ratio for individual COPC and/or reach greater than 1. pCi = picocuries. 1= EPA Region 6 SSLs. All values from EPA Region 9 HHMSSLs adjusted to TR 10⁻⁵. EPA Region 6 SSLs (2007, 101002); NMED SSLs (2006, 092513).

*- = Incomplete pathway.

Table E-2.4-3 (continued)

Noncarcinogens

Reach	Aluminum	Aroclor-1248	Aroclor-1254	Aroclor-1260	Cadmium	Iron	Lead	Manganese	Naphthalene	Silver	TATB	Thallium	Uranium (Calculated Total)	Vanadium	Hazard Index
Residential SSL (mg/kg)	77800	1.12	1.12	1.12	39.0	23500	400	3590	79.5	391	30.6	5.16	16.0	78.2	
AEN-1	0.17	-*	-	-	0.067	0.52	-	0.15	-	-	0.14	0.24	0.37	0.35	2.0
AES-1	0.19	-	-	-	-	0.58	-	0.16	-	-	-	-	-	0.32	1.3
AW-1	0.23	-	0.67	0.25	-	0.66	0.097	0.13	-	0.091	-	-	0.33	0.56	3.0
PA-0	-	-	-	-	-	-	-	-	-	-	-	-	-	-	-
PA-1E	-	-	-	-	-	-	-	-	-	-	-	-	-	-	-
PA-2W	0.13	-	-	-	-	0.49	-	0.14	-	-	-	-	0.34	0.23	1.3
PA-3E	0.15	-	-	-	-	-	0.085	0.28	-	-	-	-	-	0.22	0.73
PA-4	0.23	-	-	-	-	0.74	0.067	0.44	-	-	-	-	-	0.32	1.8
PA-5W	0.25	-	-	-	-	0.61	-	0.23	-	-	-	-	-	0.31	1.4
PAS-1E	0.18	-	-	-	-	0.74	-	0.15	-	0.11	-	-	-	0.38	1.6
PAS-2W	-	-	-	-	-	-	-	-	-	-	-	-	-	-	-
TH-1C	-	-	-	-	-	0.61	-	0.32	-	-	-	-	0.64	-	1.6
TH-1E	0.26	-	-	-	-	0.73	-	0.22	-	-	-	-	0.98	0.34	2.5
TH-3	-	-	-	-	-	-	-	-	-	-	-	-	1.3	-	1.3
THM-1	-	-	-	-	-	0.54	0.15	-	-	-	-	-	8.9	-	9.6
THS-1E	-	-	-	-	-	0.59	-	-	-	-	-	-	3.4	-	4.0
THS-1W	-	-	-	-	-	-	-	-	-	-	-	-	4.4	-	4.4
THW-1	0.20	-	-	-	-	-	-	0.12	-	-	-	-	0.92	0.26	1.5
TW-2E	-	0.14	-	-	-	0.62	-	0.11	-	-	-	-	-	0.19	1.1

Table E-2.4-3 (continued)

Noncarcinogens

Reach	Aluminum	Aroclor-1248	Aroclor-1254	Aroclor-1260	Cadmium	Iron	Lead	Manganese	Naphthalene	Silver	TATB	Thallium	Uranium (Calculated Total)	Vanadium	Hazard Index
TW-3E	-	-	-	-	-	-	-	-	-	-	-	-	-	-	-
TWN-1E	-	-	-	-	-	-	-	0.16	0.537	-	-	-	-	-	0.70
TWN-1W	-	-	-	-	-	-	-	-	-	-	-	-	-	-	-
TWSE-1E	0.14	-	-	-	-	0.53	-	0.18	-	-	-	-	-	0.22	1.1
TWSE-1W	0.21	-	-	-	-	0.63	-	-	-	-	-	-	-	0.37	1.2
TWSW-1E	0.12	-	-	-	-	-	-	0.26	-	-	-	-	0.40	0.29	1.1
TWSW-1W	0.21	-	-	-	-	0.58	-	-	-	-	-	-	-	0.31	1.1

Notes: Residential SSL are from NMED 2006, unless otherwise noted. All values from EPA Region 6 HHMSSLs adjusted to TR 10^{-5} . Bold/shaded cells: risk ratio for individual COPC and/or reach greater than 1. pCi = picocuries; 1 = EPA Region 6 SSLs. All values from EPA Region 6 HHMSSLs adjusted to TR 10^{-5} . EPA Region 6 SSLs (2007, 101002); NMED SSLs (2006, 92513).

* — = Incomplete pathway.

Table E-2.4-3 (continued)

Radionuclides

Reach	Cesium-137	Plutonium-239/240	Thorium-228	Thorium-232	Uranium-238	Total Dose Ratio	Total Dose
Residential SSL (pCi/g)	5.6	33	2.3	5	86		
AEN-1	-	-	-	-	-	-	-
AES-1	-	-	-	-	-	-	-
AW-1	-	-	-	-	-	-	-
PA-0	0.56	0.11	-	-	-	0.68	10
PA-1E	-	-	-	-	-	-	-
PA-2W	-	-	-	-	-	-	-
PA-3E	-	-	-	-	-	-	-
PA-4	0.75	-	0.79	-	-	1.5	23
PA-5W	-	-	-	-	-	-	-
PAS-1E	-	-	-	-	-	-	-
PAS-2W	-	-	-	-	-	-	-
TH-1C	-	-	-	-	-	-	-
TH-1E	-	-	-	-	-	-	-
TH-3	-	-	-	-	-	-	-
THM-1	-	-	-	-	-	-	-
THS-1E	-	-	0.86	0.35	0.21	1.4	21
THS-1W	-	-	-	-	-	-	-
THW-1	-	-	-	-	-	-	-
TW-2E	-	-	-	-	-	-	-
TW-3E	-	-	-	-	-	-	-
TWN-1E	-	-	-	-	-	-	-
TWN-1W	-	-	-	-	-	-	-

Table E-2.4-3 (continued)

Radionuclides

Reach	Cesium-137	Plutonium-239/240	Thorium-228	Thorium-232	Uranium-238	Total Dose Ratio	Total Dose
TWSE-1E	-	-	-	-	-	-	-
TWSE-1W	-	-	-	-	-	-	-
TWSW-1E	-	-	-	-	-	-	-
TWSW-1W	-	-	-	-	-	-	-

Notes: Residential SSL are from NMED 2006, unless otherwise noted. All values from EPA Region 6 HHMSSLs adjusted to TR 10^{-5} . Bold/shaded cells: risk ratio for individual COPC and/or reach greater than 1. pCi = picocuries. 1= EPA Region 6 SSLs. All values from EPA Region 6 HHMSSLs adjusted to TR 10^{-5} . EPA Region 6 SSLs (2007, 101002); NMED SSLs (2006, 092513).

* — = Incomplete pathway.

Appendix F

*Stormwater Analytical Results Greater Than Water Screening
Action Levels, Summary for Potential
Laboratory-Derived Pollutants*

The surface water and groundwater investigation described in Section 3 focused on the characterization of the nature, extent, and concentration of contaminants in persistent surface water. Stormwater results were not included in that evaluation. This appendix presents a summary of the stormwater results collected within the Pajarito watershed at persistent surface water locations from 1997 to the present. The analytical concentrations are compared with water screening action level (wSAL) values. The classification of sampling locations is divided into persistent and ephemeral categories, consistent with directions in New Mexico Environment Department § 20.6.4 and sample values compared with the associated category of wSAL values.

The table in this appendix summarizes the stormwater results for each constituent at each sampling location by year and field preparation (filtered or nonfiltered). The counts of detected concentrations (detects) and nondetects are listed. The range and average of the detected concentrations are summarized. The location stream type (perennial or ephemeral) and wSAL value are listed along with the counts of sample values exceeding the wSAL.

Location ID	Year	Field Prep	RFI Class	Analyte Name	Number of Analyses	Detected	Nondetect	Count Detect > Wsal	Count Nd > Wsal	Total Analyses > Wsal	Average	Min	Max	Stream Type	Wsal	Units	Ever Detected?
Pajarito below SR-501	2000	UF	INORGANIC	Aluminum	3	3		3		3	185115.57	13400	375947	Ephemeral	750	µg/L	Y
Pajarito below SR-501	2000	UF	INORGANIC	Ammonia as Nitrogen	3	2	1	2	1	3	3260	2120	4400	Ephemeral	39.1	µg/L	Y
Pajarito below SR-501	2000	UF	INORGANIC	Antimony	2	1	1	1	1	2	0.197	0.197	0.197	Ephemeral	640	µg/L	Y
Pajarito below SR-501	2000	UF	INORGANIC	Arsenic	3	3		3		3	46.818667	4.66	99.896	Ephemeral	9	µg/L	Y
Pajarito below SR-501	2000	UF	INORGANIC	Boron	3	3		3		3	229.80533	32	600.416	Ephemeral	5000	µg/L	Y
Pajarito below SR-501	2000	UF	INORGANIC	Cadmium	3	3		3		3	4.326	0.37	6.678	Ephemeral	2.1	µg/L	Y
Pajarito below SR-501	2000	UF	INORGANIC	Chemical Oxygen Demand	3	3		3		3	266000	229000	304000	Ephemeral	120	µg/L	Y
Pajarito below SR-501	2000	UF	INORGANIC	Chromium	3	3		3		3	132.50467	6.94	301.874	Ephemeral	580	µg/L	Y
Pajarito below SR-501	2000	UF	INORGANIC	Cobalt	3	3		3		3	95.798	8.69	206.804	Ephemeral	1000	µg/L	Y
Pajarito below SR-501	2000	UF	INORGANIC	Copper	3	3		3		3	251.2	11.5	607.1	Ephemeral	14	µg/L	Y
Pajarito below SR-501	2000	UF	INORGANIC	Cyanide [Total]	4	4		4		4	48.085	7.24	146	Ephemeral	0.0636	µg/L	Y
Pajarito below SR-501	2000	UF	INORGANIC	Cyanide, Amenable to Chlorination	3		3		3	3				Ephemeral	0.0052	µg/L	N
Pajarito below SR-501	2000	UF	INORGANIC	Lead	3	3		3		3	366.758	21.4	851.874	Ephemeral	81.7	µg/L	Y
Pajarito below SR-501	2000	UF	INORGANIC	Magnesium	3	3		3		3	50503.867	7820	112792	Ephemeral	0.0636	µg/L	Y
Pajarito below SR-501	2000	UF	INORGANIC	Mercury	3	2	1	2	1	3	0.7955	0.258	1.333	Ephemeral	0.77	µg/L	Y
Pajarito below SR-501	2000	UF	INORGANIC	Nickel	3	3		3		3	118.75267	8.73	255.128	Ephemeral	469	µg/L	Y
Pajarito below SR-501	2000	UF	INORGANIC	Nitrate-Nitrite as Nitrogen	3	3		3		3	513.33333	310	850	Ephemeral	132	µg/L	Y
Pajarito below SR-501	2000	UF	INORGANIC	Selenium	3	1	2	1	2	3	41.671	41.671	41.671	Ephemeral	5	µg/L	Y
Pajarito below SR-501	2000	UF	INORGANIC	Silver	3	1	2	1	2	3	6.085	6.085	6.085	Ephemeral	3.8	µg/L	Y
Pajarito below SR-501	2000	UF	INORGANIC	Thallium	3	2	1	2	1	3	13.9185	1.48	26.357	Ephemeral	6.3	µg/L	Y
Pajarito below SR-501	2000	UF	INORGANIC	Vanadium	3	3		3		3	286.74667	17	654.24	Ephemeral	100	µg/L	Y
Pajarito below SR-501	2000	UF	INORGANIC	Zinc	3	3		3		3	830.10933	49.8	1883.53	Ephemeral	120	µg/L	Y
Pajarito below SR-501	2000	UF	ORGANIC	Aroclor-1016	3		3		3	3				Ephemeral	0.00064	µg/L	N
Pajarito below SR-501	2000	UF	ORGANIC	Aroclor-1221	3		3		3	3				Ephemeral	0.00064	µg/L	N
Pajarito below SR-501	2000	UF	ORGANIC	Aroclor-1232	3		3		3	3				Ephemeral	0.00064	µg/L	N
Pajarito below SR-501	2000	UF	ORGANIC	Aroclor-1242	3		3		3	3				Ephemeral	0.00064	µg/L	N
Pajarito below SR-501	2000	UF	ORGANIC	Aroclor-1248	3		3		3	3				Ephemeral	0.00064	µg/L	N
Pajarito below SR-501	2000	UF	ORGANIC	Aroclor-1254	3		3		3	3				Ephemeral	0.00064	µg/L	N

Location ID	Year	Field Prep	RFI Class	Analyte Name	Number of Analyses	Detected	Nondetect	Count Detect > Wsal	Count Nd > Wsal	Total Analyses > Wsal	Average	Min	Max	Stream Type	Wsal	Units	Ever Detected?
Pajarito below SR-501	2000	UF	ORGANIC	Aroclor-1260	3		3		3	3				Ephemeral	0.00064	µg/L	N
Pajarito below SR-501	2000	UF	ORGANIC	Benzo[a]pyrene	3		3		3	3				Ephemeral	0.18	µg/L	N
Pajarito below SR-501	2000	UF	ORGANIC	Hexachlorobenzene	3		3		3	3				Ephemeral	0.0029	µg/L	N
Pajarito below SR-501	2000	UF	ORGANIC	Pentachlorophenol	3		3		3	3				Ephemeral	19	µg/L	N
Pajarito below SR-501	2000	UF	ORGANIC	RDX	2		2		2	2				Ephemeral	200	µg/L	N
Pajarito below SR-501	2000	UF	ORGANIC	Tetrachlorodibenzodioxin[2,3,7,8-]	3		3		3	3				Ephemeral	5.1E-08	µg/L	N
Pajarito below SR-501	2000	UF	ORGANIC	Tetrachloroethene	2		2		2	2				Ephemeral	33	µg/L	N
Pajarito below SR-501	2000	UF	ORGANIC	Trinitrotoluene[2,4,6-]	2		2		2	2				Ephemeral	20	µg/L	N
Pajarito below SR-501	2000	UF	RAD	Gross alpha	3	2	1	2	1	3	117.2	13.4	221	Ephemeral	15	pCi/L	Y
Pajarito below SR-501	2000	UF	RAD	Radium-226	2	1	1	1	1	2	2.95	2.95	2.95	Ephemeral	30	pCi/L	Y
Pajarito below SR-501	2000	UF	RAD	Radium-228	2	1	1	1	1	2	3.91	3.91	3.91	Ephemeral	30	pCi/L	Y
Pajarito below SR-501	2000	UF	RAD	Tritium	3		3		3	3				Ephemeral	20000	pCi/L	N
Pajarito below SR-501	2001	UF	INORGANIC	Aluminum	1	1		1		1	498000	498000	498000	Ephemeral	750	µg/L	Y
Pajarito below SR-501	2001	UF	INORGANIC	Ammonia as Nitrogen	1	1		1		1	1400	1400	1400	Ephemeral	39.1	µg/L	Y
Pajarito below SR-501	2001	UF	INORGANIC	Arsenic	1	1		1		1	98.4	98.4	98.4	Ephemeral	9	µg/L	Y
Pajarito below SR-501	2001	UF	INORGANIC	Boron	1	1		1		1	161	161	161	Ephemeral	5000	µg/L	Y
Pajarito below SR-501	2001	UF	INORGANIC	Cadmium	1	1		1		1	10.2	10.2	10.2	Ephemeral	2.1	µg/L	Y
Pajarito below SR-501	2001	UF	INORGANIC	Chemical Oxygen Demand	1	1		1		1	188000	188000	188000	Ephemeral	120	µg/L	Y
Pajarito below SR-501	2001	UF	INORGANIC	Chromium	1	1		1		1	286	286	286	Ephemeral	580	µg/L	Y
Pajarito below SR-501	2001	UF	INORGANIC	Cobalt	1	1		1		1	197	197	197	Ephemeral	1000	µg/L	Y
Pajarito below SR-501	2001	UF	INORGANIC	Copper	1	1		1		1	380	380	380	Ephemeral	14	µg/L	Y
Pajarito below SR-501	2001	UF	INORGANIC	Lead	1	1		1		1	482	482	482	Ephemeral	81.7	µg/L	Y
Pajarito below SR-501	2001	UF	INORGANIC	Magnesium	1	1		1		1	81000	81000	81000	Ephemeral	0.0636	µg/L	Y
Pajarito below SR-501	2001	UF	INORGANIC	Mercury	1		1		1	1				Ephemeral	0.77	µg/L	N
Pajarito below SR-501	2001	UF	INORGANIC	Nickel	1	1		1		1	286	286	286	Ephemeral	469	µg/L	Y
Pajarito below SR-501	2001	UF	INORGANIC	Nitrate-Nitrite as Nitrogen	1	1		1		1	1000	1000	1000	Ephemeral	132	µg/L	Y
Pajarito below SR-501	2001	UF	INORGANIC	Selenium	1	1		1		1	29	29	29	Ephemeral	5	µg/L	Y
Pajarito below SR-501	2001	UF	INORGANIC	Silver	1		1		1	1				Ephemeral	3.8	µg/L	N
Pajarito below SR-501	2001	UF	INORGANIC	Thallium	1	1		1		1	4.28	4.28	4.28	Ephemeral	6.3	µg/L	Y

Location ID	Year	Field Prep	RFI Class	Analyte Name	Number of Analyses	Detected	Nondetect	Count Detect > Wsal	Count Nd > Wsal	Total Analyses > Wsal	Average	Min	Max	Stream Type	Wsal	Units	Ever Detected?
Pajarito below SR-501	2001	UF	INORGANIC	Vanadium	1	1		1		1	468	468	468	Ephemeral	100	µg/L	Y
Pajarito below SR-501	2001	UF	INORGANIC	Zinc	1	1		1		1	1600	1600	1600	Ephemeral	120	µg/L	Y
Pajarito below SR-501	2001	UF	RAD	Gross alpha	1	1		1		1	626	626	626	Ephemeral	15	pCi/L	Y
Pajarito below SR-501	2001	UF	RAD	Radium-226	1	1		1		1	22.5	22.5	22.5	Ephemeral	30	pCi/L	Y
Pajarito below SR-501	2001	UF	RAD	Radium-228	1	1		1		1	0.961	0.961	0.961	Ephemeral	30	pCi/L	Y
Pajarito below SR-501	2005	UF	INORGANIC	Aluminum	2	2		2		2	38950	37600	40300	Ephemeral	750	µg/L	Y
Pajarito below SR-501	2005	UF	INORGANIC	Antimony	2		2		2	2				Ephemeral	640	µg/L	N
Pajarito below SR-501	2005	UF	INORGANIC	Arsenic	2		2		2	2				Ephemeral	9	µg/L	N
Pajarito below SR-501	2005	UF	INORGANIC	Cadmium	2	2		2		2	1.365	0.43	2.3	Ephemeral	2.1	µg/L	Y
Pajarito below SR-501	2005	UF	INORGANIC	Chromium	2	2		2		2	22.05	21.1	23	Ephemeral	580	µg/L	Y
Pajarito below SR-501	2005	UF	INORGANIC	Cobalt	2	2		2		2	22.1	5.4	38.8	Ephemeral	1000	µg/L	Y
Pajarito below SR-501	2005	UF	INORGANIC	Copper	2	2		2		2	28.05	18.1	38	Ephemeral	14	µg/L	Y
Pajarito below SR-501	2005	UF	INORGANIC	Lead	2	2		2		2	59.15	21.1	97.2	Ephemeral	81.7	µg/L	Y
Pajarito below SR-501	2005	UF	INORGANIC	Magnesium	2	2		2		2	8415	5430	11400	Ephemeral	0.0636	µg/L	Y
Pajarito below SR-501	2005	UF	INORGANIC	Mercury	1	1		1		1	0.19	0.19	0.19	Ephemeral	0.77	µg/L	Y
Pajarito below SR-501	2005	UF	INORGANIC	Nickel	2	2		2		2	21.2	12.5	29.9	Ephemeral	469	µg/L	Y
Pajarito below SR-501	2005	UF	INORGANIC	Selenium	2		2		2	2				Ephemeral	5	µg/L	N
Pajarito below SR-501	2005	UF	INORGANIC	Silver	2		2		2	2				Ephemeral	3.8	µg/L	N
Pajarito below SR-501	2005	UF	INORGANIC	Thallium	2	1	1	1	1	2	0.42	0.42	0.42	Ephemeral	6.3	µg/L	Y
Pajarito below SR-501	2005	UF	INORGANIC	Vanadium	2	2		2		2	56.6	35.6	77.6	Ephemeral	100	µg/L	Y
Pajarito below SR-501	2005	UF	INORGANIC	Zinc	2	2		2		2	135.8	95.6	176	Ephemeral	120	µg/L	Y
Pajarito below SR-501	2005	UF	RAD	Gross alpha	2	2		2		2	172.65	68.3	277	Ephemeral	15	pCi/L	Y
Pajarito below SR-501	2005	UF	RAD	Tritium	1	1		1		1	226	226	226	Ephemeral	20000	pCi/L	Y
Pajarito below SR-501	2006	UF	INORGANIC	Aluminum	2	2		2		2	78000	41000	115000	Ephemeral	750	µg/L	Y
Pajarito below SR-501	2006	UF	INORGANIC	Antimony	2		2		2	2				Ephemeral	640	µg/L	N
Pajarito below SR-501	2006	UF	INORGANIC	Arsenic	2	1	1	1	1	2	25.2	25.2	25.2	Ephemeral	9	µg/L	Y
Pajarito below SR-501	2006	UF	INORGANIC	Cadmium	2	2		2		2	1.7	1.1	2.3	Ephemeral	2.1	µg/L	Y
Pajarito below SR-501	2006	UF	INORGANIC	Chromium	2	2		2		2	37.15	2	72.3	Ephemeral	580	µg/L	Y
Pajarito below SR-501	2006	UF	INORGANIC	Cobalt	2	2		2		2	35.9	27.9	43.9	Ephemeral	1000	µg/L	Y

Location ID	Year	Field Prep	RFI Class	Analyte Name	Number of Analyses	Detected	Nondetect	Count Detect > Wsal	Count Nd > Wsal	Total Analyses > Wsal	Average	Min	Max	Stream Type	Wsal	Units	Ever Detected?
Pajarito below SR-501	2006	UF	INORGANIC	Copper	2	2		2		2	59.7	27.3	92.1	Ephemeral	14	µg/L	Y
Pajarito below SR-501	2006	UF	INORGANIC	Cyanide [Total]	2		2		2	2				Ephemeral	0.0636	µg/L	N
Pajarito below SR-501	2006	UF	INORGANIC	Cyanide, Amenable to Chlorination	2		2		2	2				Ephemeral	0.0052	µg/L	N
Pajarito below SR-501	2006	UF	INORGANIC	Lead	2	2		2		2	116.85	46.7	187	Ephemeral	81.7	µg/L	Y
Pajarito below SR-501	2006	UF	INORGANIC	Magnesium	2	2		2		2	14515	8830	20200	Ephemeral	0.0636	µg/L	Y
Pajarito below SR-501	2006	UF	INORGANIC	Mercury	2	1	1	1	1	2	1.1	1.1	1.1	Ephemeral	0.77	µg/L	Y
Pajarito below SR-501	2006	UF	INORGANIC	Nickel	2	2		2		2	38.05	14.5	61.6	Ephemeral	469	µg/L	Y
Pajarito below SR-501	2006	UF	INORGANIC	Selenium	2		2		2	2				Ephemeral	5	µg/L	N
Pajarito below SR-501	2006	UF	INORGANIC	Silver	2	1	1	1	1	2	0.39	0.39	0.39	Ephemeral	3.8	µg/L	Y
Pajarito below SR-501	2006	UF	INORGANIC	Thallium	2		2		2	2				Ephemeral	6.3	µg/L	N
Pajarito below SR-501	2006	UF	INORGANIC	Vanadium	2	2		2		2	96.7	52.4	141	Ephemeral	100	µg/L	Y
Pajarito below SR-501	2006	UF	INORGANIC	Zinc	2	2		2		2	320	198	442	Ephemeral	120	µg/L	Y
Pajarito below SR-501	2006	UF	RAD	Gross alpha	2	2		2		2	50.5	29.6	71.4	Ephemeral	15	pCi/L	Y
Pajarito below SR-501	2006	UF	RAD	Radium-226	2	2		2		2	5.985	5.48	6.49	Ephemeral	30	pCi/L	Y
Pajarito below SR-501	2006	UF	RAD	Tritium	2	1	1	1	1	2	242	242	242	Ephemeral	20000	pCi/L	Y
Pajarito below SR-501	2007	UF	INORGANIC	Aluminum	4	4		4		4	36642.5	1560	120000	Ephemeral	750	µg/L	Y
Pajarito below SR-501	2007	UF	INORGANIC	Antimony	3		3		3	3				Ephemeral	640	µg/L	N
Pajarito below SR-501	2007	UF	INORGANIC	Arsenic	4	1	3	1	3	4	15.8	15.8	15.8	Ephemeral	9	µg/L	Y
Pajarito below SR-501	2007	UF	INORGANIC	Cadmium	4	4		4		4	0.75	0.15	1.7	Ephemeral	2.1	µg/L	Y
Pajarito below SR-501	2007	UF	INORGANIC	Chromium	4	4		4		4	34.925	5.8	75.6	Ephemeral	580	µg/L	Y
Pajarito below SR-501	2007	UF	INORGANIC	Cobalt	4	4		4		4	18.425	2.4	34.9	Ephemeral	1000	µg/L	Y
Pajarito below SR-501	2007	UF	INORGANIC	Copper	4	4		4		4	21.025	6.6	47.6	Ephemeral	14	µg/L	Y
Pajarito below SR-501	2007	UF	INORGANIC	Cyanide [Total]	2	1	1	1	1	2	4.11	4.11	4.11	Ephemeral	0.0636	µg/L	Y
Pajarito below SR-501	2007	UF	INORGANIC	Cyanide, Amenable to Chlorination	3		3		3	3				Ephemeral	0.0052	µg/L	N
Pajarito below SR-501	2007	UF	INORGANIC	Lead	4	4		4		4	56.325	9	109	Ephemeral	81.7	µg/L	Y
Pajarito below SR-501	2007	UF	INORGANIC	Magnesium	4	4		4		4	7940	2660	19000	Ephemeral	0.0636	µg/L	Y
Pajarito below SR-501	2007	UF	INORGANIC	Mercury	4	2	2	2	2	4	0.0835	0.082	0.085	Ephemeral	0.77	µg/L	Y
Pajarito below SR-501	2007	UF	INORGANIC	Nickel	4	4		4		4	28.975	5.1	59.1	Ephemeral	469	µg/L	Y
Pajarito below SR-501	2007	UF	INORGANIC	Selenium	4		4		4	4				Ephemeral	5	µg/L	N

Location ID	Year	Field Prep	RFI Class	Analyte Name	Number of Analyses	Detected	Nondetect	Count Detect > Wsal	Count Nd > Wsal	Total Analyses > Wsal	Average	Min	Max	Stream Type	Wsal	Units	Ever Detected?
Pajarito below SR-501	2007	UF	INORGANIC	Silver	4	2	2	2	2	4	0.275	0.26	0.29	Ephemeral	3.8	µg/L	Y
Pajarito below SR-501	2007	UF	INORGANIC	Thallium	4	1	3	1	3	4	1.2	1.2	1.2	Ephemeral	6.3	µg/L	Y
Pajarito below SR-501	2007	UF	INORGANIC	Vanadium	4	4		4		4	50.275	5.6	139	Ephemeral	100	µg/L	Y
Pajarito below SR-501	2007	UF	INORGANIC	Zinc	4	4		4		4	101.475	37.1	230	Ephemeral	120	µg/L	Y
Pajarito below SR-501	2007	UF	RAD	Gross alpha	4	3	1	3	1	4	32.89	9.67	76.1	Ephemeral	15	pCi/L	Y
Pajarito below SR-501	2007	UF	RAD	Tritium	1		1		1	1				Ephemeral	20000	pCi/L	N
Pajarito above Starmers	2000	UF	INORGANIC	Aluminum	1	1		1		1	70784.11	70784.1	70784.1	Ephemeral	750	µg/L	Y
Pajarito above Starmers	2000	UF	INORGANIC	Ammonia as Nitrogen	1	1		1		1	1900	1900	1900	Ephemeral	39.1	µg/L	Y
Pajarito above Starmers	2000	UF	INORGANIC	Arsenic	1	1		1		1	48.586	48.586	48.586	Ephemeral	9	µg/L	Y
Pajarito above Starmers	2000	UF	INORGANIC	Boron	1	1		1		1	274.583	274.583	274.583	Ephemeral	5000	µg/L	Y
Pajarito above Starmers	2000	UF	INORGANIC	Cadmium	1	1		1		1	3.568	3.568	3.568	Ephemeral	2.1	µg/L	Y
Pajarito above Starmers	2000	UF	INORGANIC	Chemical Oxygen Demand	1	1		1		1	332000	332000	332000	Ephemeral	120	µg/L	Y
Pajarito above Starmers	2000	UF	INORGANIC	Chromium	1	1		1		1	61.893	61.893	61.893	Ephemeral	580	µg/L	Y
Pajarito above Starmers	2000	UF	INORGANIC	Cobalt	1	1		1		1	32.055	32.055	32.055	Ephemeral	1000	µg/L	Y
Pajarito above Starmers	2000	UF	INORGANIC	Copper	1	1		1		1	106.374	106.374	106.374	Ephemeral	14	µg/L	Y
Pajarito above Starmers	2000	UF	INORGANIC	Cyanide [Total]	1	1		1		1	115	115	115	Ephemeral	0.0636	µg/L	Y
Pajarito above Starmers	2000	UF	INORGANIC	Cyanide, Amenable to Chlorination	1		1		1	1				Ephemeral	0.0052	µg/L	N
Pajarito above Starmers	2000	UF	INORGANIC	Lead	1	1		1		1	157.545	157.545	157.545	Ephemeral	81.7	µg/L	Y
Pajarito above Starmers	2000	UF	INORGANIC	Magnesium	1	1		1		1	24078.33	24078.3	24078.3	Ephemeral	0.0636	µg/L	Y
Pajarito above Starmers	2000	UF	INORGANIC	Mercury	1	1		1		1	0.452	0.452	0.452	Ephemeral	0.77	µg/L	Y
Pajarito above Starmers	2000	UF	INORGANIC	Nickel	1	1		1		1	76.38	76.38	76.38	Ephemeral	469	µg/L	Y
Pajarito above Starmers	2000	UF	INORGANIC	Nitrate-Nitrite as Nitrogen	1	1		1		1	1100	1100	1100	Ephemeral	132	µg/L	Y
Pajarito above Starmers	2000	UF	INORGANIC	Selenium	1	1		1		1	50.295	50.295	50.295	Ephemeral	5	µg/L	Y
Pajarito above Starmers	2000	UF	INORGANIC	Silver	1	1		1		1	12.049	12.049	12.049	Ephemeral	3.8	µg/L	Y
Pajarito above Starmers	2000	UF	INORGANIC	Thallium	1	1		1		1	47.595	47.595	47.595	Ephemeral	6.3	µg/L	Y
Pajarito above Starmers	2000	UF	INORGANIC	Vanadium	1	1		1		1	105.149	105.149	105.149	Ephemeral	100	µg/L	Y
Pajarito above Starmers	2000	UF	INORGANIC	Zinc	1	1		1		1	491.74	491.74	491.74	Ephemeral	120	µg/L	Y
Pajarito above Starmers	2000	UF	ORGANIC	Aroclor-1016	1		1		1	1				Ephemeral	0.00064	µg/L	N
Pajarito above Starmers	2000	UF	ORGANIC	Aroclor-1221	1		1		1	1				Ephemeral	0.00064	µg/L	N

Location ID	Year	Field Prep	RFI Class	Analyte Name	Number of Analyses	Detected	Nondetect	Count Detect > Wsal	Count Nd > Wsal	Total Analyses > Wsal	Average	Min	Max	Stream Type	Wsal	Units	Ever Detected?
Pajarito above Starmers	2000	UF	ORGANIC	Aroclor-1232	1		1		1	1				Ephemeral	0.00064	µg/L	N
Pajarito above Starmers	2000	UF	ORGANIC	Aroclor-1242	1		1		1	1				Ephemeral	0.00064	µg/L	N
Pajarito above Starmers	2000	UF	ORGANIC	Aroclor-1248	1		1		1	1				Ephemeral	0.00064	µg/L	N
Pajarito above Starmers	2000	UF	ORGANIC	Aroclor-1254	1		1		1	1				Ephemeral	0.00064	µg/L	N
Pajarito above Starmers	2000	UF	ORGANIC	Aroclor-1260	1		1		1	1				Ephemeral	0.00064	µg/L	N
Pajarito above Starmers	2000	UF	RAD	Gross alpha	1	1		1		1	56.5	56.5	56.5	Ephemeral	15	pCi/L	Y
Pajarito above Starmers	2000	UF	RAD	Tritium	1		1		1	1				Ephemeral	20000	pCi/L	N
Pajarito above Starmers	2002	UF	INORGANIC	Aluminum	1	1		1		1	44400	44400	44400	Ephemeral	750	µg/L	Y
Pajarito above Starmers	2002	UF	INORGANIC	Ammonia as Nitrogen	1	1		1		1	550	550	550	Ephemeral	39.1	µg/L	Y
Pajarito above Starmers	2002	UF	INORGANIC	Antimony	1	1		1		1	0.287	0.287	0.287	Ephemeral	640	µg/L	Y
Pajarito above Starmers	2002	UF	INORGANIC	Arsenic	1	1		1		1	9.13	9.13	9.13	Ephemeral	9	µg/L	Y
Pajarito above Starmers	2002	UF	INORGANIC	Boron	1	1		1		1	27.7	27.7	27.7	Ephemeral	5000	µg/L	Y
Pajarito above Starmers	2002	UF	INORGANIC	Cadmium	1	1		1		1	5.6	5.6	5.6	Ephemeral	2.1	µg/L	Y
Pajarito above Starmers	2002	UF	INORGANIC	Chemical Oxygen Demand	1	1		1		1	213000	213000	213000	Ephemeral	120	µg/L	Y
Pajarito above Starmers	2002	UF	INORGANIC	Chromium	1	1		1		1	5.67	5.67	5.67	Ephemeral	580	µg/L	Y
Pajarito above Starmers	2002	UF	INORGANIC	Cobalt	1	1		1		1	102	102	102	Ephemeral	1000	µg/L	Y
Pajarito above Starmers	2002	UF	INORGANIC	Copper	1	1		1		1	21.8	21.8	21.8	Ephemeral	14	µg/L	Y
Pajarito above Starmers	2002	UF	INORGANIC	Cyanide [Total]	1	1		1		1	6.92	6.92	6.92	Ephemeral	0.0636	µg/L	Y
Pajarito above Starmers	2002	UF	INORGANIC	Cyanide, Amenable to Chlorination	1		1		1	1				Ephemeral	0.0052	µg/L	N
Pajarito above Starmers	2002	UF	INORGANIC	Lead	1	1		1		1	36.9	36.9	36.9	Ephemeral	81.7	µg/L	Y
Pajarito above Starmers	2002	UF	INORGANIC	Mercury	1	1		1		1	0.184	0.184	0.184	Ephemeral	0.77	µg/L	Y
Pajarito above Starmers	2002	UF	INORGANIC	Nickel	1	1		1		1	42.6	42.6	42.6	Ephemeral	469	µg/L	Y
Pajarito above Starmers	2002	UF	INORGANIC	Nitrate-Nitrite as Nitrogen	1	1		1		1	1450	1450	1450	Ephemeral	132	µg/L	Y
Pajarito above Starmers	2002	UF	INORGANIC	Selenium	1	1		1		1	3	3	3	Ephemeral	5	µg/L	Y
Pajarito above Starmers	2002	UF	INORGANIC	Silver	1	1		1		1	1.81	1.81	1.81	Ephemeral	3.8	µg/L	Y
Pajarito above Starmers	2002	UF	INORGANIC	Thallium	1	1		1		1	0.381	0.381	0.381	Ephemeral	6.3	µg/L	Y
Pajarito above Starmers	2002	UF	INORGANIC	Vanadium	1	1		1		1	58.9	58.9	58.9	Ephemeral	100	µg/L	Y
Pajarito above Starmers	2002	UF	INORGANIC	Zinc	1	1		1		1	393	393	393	Ephemeral	120	µg/L	Y
Pajarito above Starmers	2002	UF	RAD	Gross alpha	1	1		1		1	1630	1630	1630	Ephemeral	15	pCi/L	Y

Location ID	Year	Field Prep	RFI Class	Analyte Name	Number of Analyses	Detected	Nondetect	Count Detect > Wsal	Count Nd > Wsal	Total Analyses > Wsal	Average	Min	Max	Stream Type	Wsal	Units	Ever Detected?
Pajarito above Starmers	2002	UF	RAD	Radium-226	1	1		1		1	6.98	6.98	6.98	Ephemeral	30	pCi/L	Y
Pajarito above Starmers	2002	UF	RAD	Radium-228	1	1		1		1	30.5	30.5	30.5	Ephemeral	30	pCi/L	Y
Pajarito above Starmers	2002	UF	RAD	Tritium	2		2		2	2				Ephemeral	20000	pCi/L	N
Pajarito above Starmers	2001	UF	INORGANIC	Aluminum	2	2		2		2	153950	97900	210000	Ephemeral	750	µg/L	Y
Pajarito above Starmers	2001	UF	INORGANIC	Ammonia as Nitrogen	2	2		2		2	305	140	470	Ephemeral	39.1	µg/L	Y
Pajarito above Starmers	2001	UF	INORGANIC	Antimony	1	1		1		1	1.46	1.46	1.46	Ephemeral	640	µg/L	Y
Pajarito above Starmers	2001	UF	INORGANIC	Arsenic	2	2		2		2	29.9	17	42.8	Ephemeral	9	µg/L	Y
Pajarito above Starmers	2001	UF	INORGANIC	Boron	2	2		2		2	43.65	42.4	44.9	Ephemeral	5000	µg/L	Y
Pajarito above Starmers	2001	UF	INORGANIC	Cadmium	2	2		2		2	4.795	2.64	6.95	Ephemeral	2.1	µg/L	Y
Pajarito above Starmers	2001	UF	INORGANIC	Chemical Oxygen Demand	2	2		2		2	59550	58800	60300	Ephemeral	120	µg/L	Y
Pajarito above Starmers	2001	UF	INORGANIC	Chromium	2	2		2		2	80.15	54.3	106	Ephemeral	580	µg/L	Y
Pajarito above Starmers	2001	UF	INORGANIC	Cobalt	2	2		2		2	55.2	32.4	78	Ephemeral	1000	µg/L	Y
Pajarito above Starmers	2001	UF	INORGANIC	Copper	2	2		2		2	105.75	63.5	148	Ephemeral	14	µg/L	Y
Pajarito above Starmers	2001	UF	INORGANIC	Cyanide [Total]	2	1	1	1	1	2	9.95	9.95	9.95	Ephemeral	0.0636	µg/L	Y
Pajarito above Starmers	2001	UF	INORGANIC	Cyanide, Amenable to Chlorination	2		2		2	2				Ephemeral	0.0052	µg/L	N
Pajarito above Starmers	2001	UF	INORGANIC	Lead	2	2		2		2	212.5	107	318	Ephemeral	81.7	µg/L	Y
Pajarito above Starmers	2001	UF	INORGANIC	Magnesium	2	2		2		2	25400	15200	35600	Ephemeral	0.0636	µg/L	Y
Pajarito above Starmers	2001	UF	INORGANIC	Mercury	2		2		2	2				Ephemeral	0.77	µg/L	N
Pajarito above Starmers	2001	UF	INORGANIC	Nickel	2	2		2		2	79	47	111	Ephemeral	469	µg/L	Y
Pajarito above Starmers	2001	UF	INORGANIC	Nitrate-Nitrite as Nitrogen	2	2		2		2	1075	860	1290	Ephemeral	132	µg/L	Y
Pajarito above Starmers	2001	UF	INORGANIC	Selenium	2	2		2		2	5.985	2.99	8.98	Ephemeral	5	µg/L	Y
Pajarito above Starmers	2001	UF	INORGANIC	Silver	2		2		2	2				Ephemeral	3.8	µg/L	N
Pajarito above Starmers	2001	UF	INORGANIC	Thallium	2	2		2		2	1.775	1.02	2.53	Ephemeral	6.3	µg/L	Y
Pajarito above Starmers	2001	UF	INORGANIC	Vanadium	2	2		2		2	149.5	100	199	Ephemeral	100	µg/L	Y
Pajarito above Starmers	2001	UF	INORGANIC	Zinc	2	2		2		2	504.5	281	728	Ephemeral	120	µg/L	Y
Pajarito above Starmers	2001	UF	RAD	Gross alpha	3	3		3		3	127.03333	89.1	150	Ephemeral	15	pCi/L	Y
Pajarito above Starmers	2001	UF	RAD	Radium-226	3	3		3		3	6.1766667	2.86	8.11	Ephemeral	30	pCi/L	Y
Pajarito above Starmers	2001	UF	RAD	Radium-228	3	3		3		3	4.4133333	2.04	6.53	Ephemeral	30	pCi/L	Y
Pajarito above Starmers	2001	UF	RAD	Tritium	1	1		1		1	449	449	449	Ephemeral	20000	pCi/L	Y

Location ID	Year	Field Prep	RFI Class	Analyte Name	Number of Analyses	Detected	Nondetect	Count Detect > Wsal	Count Nd > Wsal	Total Analyses > Wsal	Average	Min	Max	Stream Type	Wsal	Units	Ever Detected?
Pajarito above Starmers	2003	F	INORGANIC	Chemical Oxygen Demand	2	2		2		2	63350	56300	70400	Ephemeral	120	µg/L	Y
Pajarito above Starmers	2003	F	INORGANIC	Nitrate-Nitrite as Nitrogen	2	2		2		2	840	670	1010	Ephemeral	132	µg/L	Y
Pajarito above Starmers	2003	UF	INORGANIC	Aluminum	1	1		1		1	385000	385000	385000	Ephemeral	750	µg/L	Y
Pajarito above Starmers	2003	UF	INORGANIC	Antimony	1		1		1	1				Ephemeral	640	µg/L	N
Pajarito above Starmers	2003	UF	INORGANIC	Arsenic	1	1		1		1	70.9	70.9	70.9	Ephemeral	9	µg/L	Y
Pajarito above Starmers	2003	UF	INORGANIC	Boron	1	1		1		1	120	120	120	Ephemeral	5000	µg/L	Y
Pajarito above Starmers	2003	UF	INORGANIC	Cadmium	1	1		1		1	7.63	7.63	7.63	Ephemeral	2.1	µg/L	Y
Pajarito above Starmers	2003	UF	INORGANIC	Chromium	1	1		1		1	234	234	234	Ephemeral	580	µg/L	Y
Pajarito above Starmers	2003	UF	INORGANIC	Cobalt	1	1		1		1	159	159	159	Ephemeral	1000	µg/L	Y
Pajarito above Starmers	2003	UF	INORGANIC	Copper	1	1		1		1	252	252	252	Ephemeral	14	µg/L	Y
Pajarito above Starmers	2003	UF	INORGANIC	Cyanide [Total]	2	1	1	1	1	2	11.8	11.8	11.8	Ephemeral	0.0636	µg/L	Y
Pajarito above Starmers	2003	UF	INORGANIC	Cyanide, Amenable to Chlorination	2		2		2	2				Ephemeral	0.0052	µg/L	N
Pajarito above Starmers	2003	UF	INORGANIC	Lead	1	1		1		1	299	299	299	Ephemeral	81.7	µg/L	Y
Pajarito above Starmers	2003	UF	INORGANIC	Nickel	1	1		1		1	225	225	225	Ephemeral	469	µg/L	Y
Pajarito above Starmers	2003	UF	INORGANIC	Selenium	1		1		1	1				Ephemeral	5	µg/L	N
Pajarito above Starmers	2003	UF	INORGANIC	Silver	1		1		1	1				Ephemeral	3.8	µg/L	N
Pajarito above Starmers	2003	UF	INORGANIC	Thallium	1	1		1		1	3.34	3.34	3.34	Ephemeral	6.3	µg/L	Y
Pajarito above Starmers	2003	UF	INORGANIC	Vanadium	1	1		1		1	396	396	396	Ephemeral	100	µg/L	Y
Pajarito above Starmers	2003	UF	INORGANIC	Zinc	1	1		1		1	1370	1370	1370	Ephemeral	120	µg/L	Y
Pajarito above Starmers	2003	UF	RAD	Gross alpha	2	2		2		2	56.4	43.6	69.2	Ephemeral	15	pCi/L	Y
Pajarito above Starmers	2003	UF	RAD	Radium-226	2	2		2		2	15.65	12.9	18.4	Ephemeral	30	pCi/L	Y
Pajarito above Starmers	2003	UF	RAD	Radium-228	2	2		2		2	17.15	16.4	17.9	Ephemeral	30	pCi/L	Y
Pajarito above Starmers	2005	UF	INORGANIC	Aluminum	4	4		4		4	39825	17700	92700	Ephemeral	750	µg/L	Y
Pajarito above Starmers	2005	UF	INORGANIC	Antimony	4	2	2	2	2	4	1.395	0.59	2.2	Ephemeral	640	µg/L	Y
Pajarito above Starmers	2005	UF	INORGANIC	Arsenic	4	2	2	2	2	4	11.95	6.8	17.1	Ephemeral	9	µg/L	Y
Pajarito above Starmers	2005	UF	INORGANIC	Cadmium	4	4		4		4	1.6	0.5	3.5	Ephemeral	2.1	µg/L	Y
Pajarito above Starmers	2005	UF	INORGANIC	Chromium	4	4		4		4	23.675	10.2	56.1	Ephemeral	580	µg/L	Y
Pajarito above Starmers	2005	UF	INORGANIC	Cobalt	4	4		4		4	24.95	16.5	47.8	Ephemeral	1000	µg/L	Y
Pajarito above Starmers	2005	UF	INORGANIC	Copper	4	3	1	3	1	4	33.833333	21.3	57.6	Ephemeral	14	µg/L	Y

Location ID	Year	Field Prep	RFI Class	Analyte Name	Number of Analyses	Detected	Nondetect	Count Detect > Wsal	Count Nd > Wsal	Total Analyses > Wsal	Average	Min	Max	Stream Type	Wsal	Units	Ever Detected?
Pajarito above Starmers	2005	UF	INORGANIC	Lead	4	4		4		4	78.325	32.5	171	Ephemeral	81.7	µg/L	Y
Pajarito above Starmers	2005	UF	INORGANIC	Magnesium	4	4		4		4	9740	5210	18500	Ephemeral	0.0636	µg/L	Y
Pajarito above Starmers	2005	UF	INORGANIC	Mercury	4	4		4		4	0.16	0.11	0.22	Ephemeral	0.77	µg/L	Y
Pajarito above Starmers	2005	UF	INORGANIC	Nickel	4	4		4		4	35.4	12.7	88.4	Ephemeral	469	µg/L	Y
Pajarito above Starmers	2005	UF	INORGANIC	Selenium	4		4		4	4				Ephemeral	5	µg/L	N
Pajarito above Starmers	2005	UF	INORGANIC	Silver	4		4		4	4				Ephemeral	3.8	µg/L	N
Pajarito above Starmers	2005	UF	INORGANIC	Thallium	4	2	2	2	2	4	1.645	0.69	2.6	Ephemeral	6.3	µg/L	Y
Pajarito above Starmers	2005	UF	INORGANIC	Vanadium	4	4		4		4	63	33.3	134	Ephemeral	100	µg/L	Y
Pajarito above Starmers	2005	UF	INORGANIC	Zinc	4	4		4		4	240	116	492	Ephemeral	120	µg/L	Y
Pajarito above Starmers	2006	UF	INORGANIC	Aluminum	2	2		2		2	61250	37900	84600	Ephemeral	750	µg/L	Y
Pajarito above Starmers	2006	UF	INORGANIC	Arsenic	2	2		2		2	9.95	8.1	11.8	Ephemeral	9	µg/L	Y
Pajarito above Starmers	2006	UF	INORGANIC	Cadmium	2	2		2		2	0.64	0.55	0.73	Ephemeral	2.1	µg/L	Y
Pajarito above Starmers	2006	UF	INORGANIC	Chromium	2	2		2		2	25.85	15.7	36	Ephemeral	580	µg/L	Y
Pajarito above Starmers	2006	UF	INORGANIC	Copper	2	2		2		2	34.85	25	44.7	Ephemeral	14	µg/L	Y
Pajarito above Starmers	2006	UF	INORGANIC	Cyanide [Total]	2		2		2	2				Ephemeral	0.0636	µg/L	N
Pajarito above Starmers	2006	UF	INORGANIC	Cyanide, Amenable to Chlorination	2		2		2	2				Ephemeral	0.0052	µg/L	N
Pajarito above Starmers	2006	UF	INORGANIC	Lead	2	1	1	1	1	2	66.3	66.3	66.3	Ephemeral	81.7	µg/L	Y
Pajarito above Starmers	2006	UF	INORGANIC	Magnesium	2	2		2		2	12675	8950	16400	Ephemeral	0.0636	µg/L	Y
Pajarito above Starmers	2006	UF	INORGANIC	Selenium	2		2		2	2				Ephemeral	5	µg/L	N
Pajarito above Starmers	2006	UF	INORGANIC	Silver	2		2		2	2				Ephemeral	3.8	µg/L	N
Pajarito above Starmers	2006	UF	INORGANIC	Thallium	2	1	1	1	1	2	0.42	0.42	0.42	Ephemeral	6.3	µg/L	Y
Pajarito above Starmers	2006	UF	INORGANIC	Vanadium	2	2		2		2	80.35	50.7	110	Ephemeral	100	µg/L	Y
Pajarito above Starmers	2006	UF	INORGANIC	Zinc	2	2		2		2	220	161	279	Ephemeral	120	µg/L	Y
Pajarito above Starmers	2004	UF	INORGANIC	Aluminum	1	1		1		1	8590	8590	8590	Ephemeral	750	µg/L	Y
Pajarito above Starmers	2004	UF	INORGANIC	Antimony	1		1		1	1				Ephemeral	640	µg/L	N
Pajarito above Starmers	2004	UF	INORGANIC	Arsenic	1		1		1	1				Ephemeral	9	µg/L	N
Pajarito above Starmers	2004	UF	INORGANIC	Boron	1	1		1		1	16.3	16.3	16.3	Ephemeral	5000	µg/L	Y
Pajarito above Starmers	2004	UF	INORGANIC	Cadmium	1	1		1		1	2.9	2.9	2.9	Ephemeral	2.1	µg/L	Y
Pajarito above Starmers	2004	UF	INORGANIC	Chromium	1	1		1		1	1.7	1.7	1.7	Ephemeral	580	µg/L	Y

Location ID	Year	Field Prep	RFI Class	Analyte Name	Number of Analyses	Detected	Nondetect	Count Detect > Wsal	Count Nd > Wsal	Total Analyses > Wsal	Average	Min	Max	Stream Type	Wsal	Units	Ever Detected?
Pajarito above Starmers	2004	UF	INORGANIC	Cobalt	1	1		1		1	28.9	28.9	28.9	Ephemeral	1000	µg/L	Y
Pajarito above Starmers	2004	UF	INORGANIC	Copper	1	1		1		1	25.8	25.8	25.8	Ephemeral	14	µg/L	Y
Pajarito above Starmers	2004	UF	INORGANIC	Lead	1	1		1		1	76	76	76	Ephemeral	81.7	µg/L	Y
Pajarito above Starmers	2004	UF	INORGANIC	Magnesium	1	1		1		1	10300	10300	10300	Ephemeral	0.0636	µg/L	Y
Pajarito above Starmers	2004	UF	INORGANIC	Mercury	1	1		1		1	0.13	0.13	0.13	Ephemeral	0.77	µg/L	Y
Pajarito above Starmers	2004	UF	INORGANIC	Nickel	1	1		1		1	24	24	24	Ephemeral	469	µg/L	Y
Pajarito above Starmers	2004	UF	INORGANIC	Selenium	1		1		1	1				Ephemeral	5	µg/L	N
Pajarito above Starmers	2004	UF	INORGANIC	Silver	1		1		1	1				Ephemeral	3.8	µg/L	N
Pajarito above Starmers	2004	UF	INORGANIC	Thallium	1	1		1		1	0.99	0.99	0.99	Ephemeral	6.3	µg/L	Y
Pajarito above Starmers	2004	UF	INORGANIC	Vanadium	1	1		1		1	46.9	46.9	46.9	Ephemeral	100	µg/L	Y
Pajarito above Starmers	2004	UF	INORGANIC	Zinc	1	1		1		1	193	193	193	Ephemeral	120	µg/L	Y
Pajarito above Starmers	2007	UF	INORGANIC	Aluminum	4	4		4		4	33507.5	4630	69300	Ephemeral	750	µg/L	Y
Pajarito above Starmers	2007	UF	INORGANIC	Antimony	4		4		4	4				Ephemeral	640	µg/L	N
Pajarito above Starmers	2007	UF	INORGANIC	Arsenic	4	2	2	2	2	4	10.4	6.5	14.3	Ephemeral	9	µg/L	Y
Pajarito above Starmers	2007	UF	INORGANIC	Cadmium	4	3	1	3	1	4	1.7166667	0.85	2.2	Ephemeral	2.1	µg/L	Y
Pajarito above Starmers	2007	UF	INORGANIC	Chromium	4	4		4		4	26.925	2.4	51.3	Ephemeral	580	µg/L	Y
Pajarito above Starmers	2007	UF	INORGANIC	Cobalt	4	3	1	3	1	4	28.633333	13.6	47	Ephemeral	1000	µg/L	Y
Pajarito above Starmers	2007	UF	INORGANIC	Copper	4	3	1	3	1	4	40.766667	39.4	42.9	Ephemeral	14	µg/L	Y
Pajarito above Starmers	2007	UF	INORGANIC	Cyanide [Total]	4	3	1	3	1	4	2.7933333	1.81	4.35	Ephemeral	0.0636	µg/L	Y
Pajarito above Starmers	2007	UF	INORGANIC	Cyanide, Amenable to Chlorination	4		4		4	4				Ephemeral	0.0052	µg/L	N
Pajarito above Starmers	2007	UF	INORGANIC	Lead	4	4		4		4	78.475	1.8	157	Ephemeral	81.7	µg/L	Y
Pajarito above Starmers	2007	UF	INORGANIC	Magnesium	4	4		4		4	9037.5	3550	11500	Ephemeral	0.0636	µg/L	Y
Pajarito above Starmers	2007	UF	INORGANIC	Mercury	4	3	1	3	1	4	0.12	0.034	0.28	Ephemeral	0.77	µg/L	Y
Pajarito above Starmers	2007	UF	INORGANIC	Nickel	4	4		4		4	29.225	2	47.1	Ephemeral	469	µg/L	Y
Pajarito above Starmers	2007	UF	INORGANIC	Selenium	4	1	3	1	3	4	1.6	1.6	1.6	Ephemeral	5	µg/L	Y
Pajarito above Starmers	2007	UF	INORGANIC	Silver	4	1	3	1	3	4	0.39	0.39	0.39	Ephemeral	3.8	µg/L	Y
Pajarito above Starmers	2007	UF	INORGANIC	Thallium	4	1	3	1	3	4	0.34	0.34	0.34	Ephemeral	6.3	µg/L	Y
Pajarito above Starmers	2007	UF	INORGANIC	Vanadium	4	4		4		4	55.075	4.4	90.3	Ephemeral	100	µg/L	Y
Pajarito above Starmers	2007	UF	INORGANIC	Zinc	4	4		4		4	267.45	18.8	430	Ephemeral	120	µg/L	Y

Location ID	Year	Field Prep	RFI Class	Analyte Name	Number of Analyses	Detected	Nondetect	Count Detect > Wsal	Count Nd > Wsal	Total Analyses > Wsal	Average	Min	Max	Stream Type	Wsal	Units	Ever Detected?
Pajarito above Starmers	2007	UF	RAD	Gross alpha	4	4		4		4	48.9125	2.15	89.6	Ephemeral	15	pCi/L	Y
Starmers above Pajarito	2000	UF	INORGANIC	Aluminum	1	1		1		1	64574.17	64574.2	64574.2	Perennial	87	µg/L	Y
Starmers above Pajarito	2000	UF	INORGANIC	Ammonia as Nitrogen	1	1		1		1	2700	2700	2700	Perennial	8.19	µg/L	Y
Starmers above Pajarito	2000	UF	INORGANIC	Arsenic	1	1		1		1	35.229	35.229	35.229	Perennial	9	µg/L	Y
Starmers above Pajarito	2000	UF	INORGANIC	Boron	1	1		1		1	252.356	252.356	252.356	Perennial	5000	µg/L	Y
Starmers above Pajarito	2000	UF	INORGANIC	Cadmium	1	1		1		1	2.954	2.954	2.954	Perennial	0.28	µg/L	Y
Starmers above Pajarito	2000	UF	INORGANIC	Chemical Oxygen Demand	1	1		1		1	346000	346000	346000	Perennial	120	µg/L	Y
Starmers above Pajarito	2000	UF	INORGANIC	Chromium	1	1		1		1	41.393	41.393	41.393	Perennial	77	µg/L	Y
Starmers above Pajarito	2000	UF	INORGANIC	Cobalt	1	1		1		1	47.86	47.86	47.86	Perennial	1000	µg/L	Y
Starmers above Pajarito	2000	UF	INORGANIC	Copper	1	1		1		1	99.783	99.783	99.783	Perennial	9.4	µg/L	Y
Starmers above Pajarito	2000	UF	INORGANIC	Cyanide [Total]	1	1		1		1	84	84	84	Perennial	0.0636	µg/L	Y
Starmers above Pajarito	2000	UF	INORGANIC	Cyanide, Amenable to Chlorination	1		1		1	1				Perennial	0.0052	µg/L	N
Starmers above Pajarito	2000	UF	INORGANIC	Lead	1	1		1		1	135.885	135.885	135.885	Perennial	3.2	µg/L	Y
Starmers above Pajarito	2000	UF	INORGANIC	Magnesium	1	1		1		1	26717.28	26717.3	26717.3	Perennial	0.0636	µg/L	Y
Starmers above Pajarito	2000	UF	INORGANIC	Mercury	1	1		1		1	0.184	0.184	0.184	Perennial	0.77	µg/L	Y
Starmers above Pajarito	2000	UF	INORGANIC	Nickel	1	1		1		1	56.272	56.272	56.272	Perennial	52	µg/L	Y
Starmers above Pajarito	2000	UF	INORGANIC	Nitrate-Nitrite as Nitrogen	1	1		1		1	520	520	520	Perennial	132	µg/L	Y
Starmers above Pajarito	2000	UF	INORGANIC	Selenium	1	1		1		1	22.336	22.336	22.336	Perennial	5	µg/L	Y
Starmers above Pajarito	2000	UF	INORGANIC	Silver	1	1		1		1	6.759	6.759	6.759	Perennial	3.8	µg/L	Y
Starmers above Pajarito	2000	UF	INORGANIC	Thallium	1	1		1		1	17.228	17.228	17.228	Perennial	6.3	µg/L	Y
Starmers above Pajarito	2000	UF	INORGANIC	Vanadium	1	1		1		1	101.669	101.669	101.669	Perennial	100	µg/L	Y
Starmers above Pajarito	2000	UF	INORGANIC	Zinc	1	1		1		1	588.097	588.097	588.097	Perennial	120	µg/L	Y
Starmers above Pajarito	2000	UF	ORGANIC	Acenaphthene	1		1		1	1				Perennial	990	µg/L	N
Starmers above Pajarito	2000	UF	ORGANIC	Anthracene	1		1		1	1				Perennial	40000	µg/L	N
Starmers above Pajarito	2000	UF	ORGANIC	Aroclor-1016	1		1		1	1				Perennial	0.00064	µg/L	N
Starmers above Pajarito	2000	UF	ORGANIC	Aroclor-1221	1		1		1	1				Perennial	0.00064	µg/L	N
Starmers above Pajarito	2000	UF	ORGANIC	Aroclor-1232	1		1		1	1				Perennial	0.00064	µg/L	N
Starmers above Pajarito	2000	UF	ORGANIC	Aroclor-1242	1		1		1	1				Perennial	0.00064	µg/L	N
Starmers above Pajarito	2000	UF	ORGANIC	Aroclor-1248	1		1		1	1				Perennial	0.00064	µg/L	N

Location ID	Year	Field Prep	RFI Class	Analyte Name	Number of Analyses	Detected	Nondetect	Count Detect > Wsal	Count Nd > Wsal	Total Analyses > Wsal	Average	Min	Max	Stream Type	Wsal	Units	Ever Detected?
Starmers above Pajarito	2000	UF	ORGANIC	Aroclor-1254	1		1		1	1				Perennial	0.00064	µg/L	N
Starmers above Pajarito	2000	UF	ORGANIC	Aroclor-1260	1		1		1	1				Perennial	0.00064	µg/L	N
Starmers above Pajarito	2000	UF	ORGANIC	Benzo[a]anthracene	1		1		1	1				Perennial	0.18	µg/L	N
Starmers above Pajarito	2000	UF	ORGANIC	Benzo[a]pyrene	1		1		1	1				Perennial	0.18	µg/L	N
Starmers above Pajarito	2000	UF	ORGANIC	Benzo[b]fluoranthene	1		1		1	1				Perennial	0.18	µg/L	N
Starmers above Pajarito	2000	UF	ORGANIC	Benzo[k]fluoranthene	1		1		1	1				Perennial	0.18	µg/L	N
Starmers above Pajarito	2000	UF	ORGANIC	Bis[2-chloroethyl]ether	1		1		1	1				Perennial	5.3	µg/L	N
Starmers above Pajarito	2000	UF	ORGANIC	Bis[2-ethylhexyl]phthalate	1		1		1	1				Perennial	22	µg/L	N
Starmers above Pajarito	2000	UF	ORGANIC	Butylbenzylphthalate	1		1		1	1				Perennial	1900	µg/L	N
Starmers above Pajarito	2000	UF	ORGANIC	Chloronaphthalene[2-]	1		1		1	1				Perennial	1600	µg/L	N
Starmers above Pajarito	2000	UF	ORGANIC	Chlorophenol[2-]	1		1		1	1				Perennial	150	µg/L	N
Starmers above Pajarito	2000	UF	ORGANIC	Chrysene	1		1		1	1				Perennial	0.18	µg/L	N
Starmers above Pajarito	2000	UF	ORGANIC	Dibenz[a,h]anthracene	1		1		1	1				Perennial	0.18	µg/L	N
Starmers above Pajarito	2000	UF	ORGANIC	Dichlorobenzene[1,2-]	1		1		1	1				Perennial	17000	µg/L	N
Starmers above Pajarito	2000	UF	ORGANIC	Dichlorobenzene[1,3-]	1		1		1	1				Perennial	960	µg/L	N
Starmers above Pajarito	2000	UF	ORGANIC	Dichlorobenzene[1,4-]	1		1		1	1				Perennial	2600	µg/L	N
Starmers above Pajarito	2000	UF	ORGANIC	Dichlorobenzidine[3,3'-]	1		1		1	1				Perennial	0.28	µg/L	N
Starmers above Pajarito	2000	UF	ORGANIC	Dichlorophenol[2,4-]	1		1		1	1				Perennial	290	µg/L	N
Starmers above Pajarito	2000	UF	ORGANIC	Diethylphthalate	1		1		1	1				Perennial	44000	µg/L	N
Starmers above Pajarito	2000	UF	ORGANIC	Dimethyl Phthalate	1		1		1	1				Perennial	1100000	µg/L	N
Starmers above Pajarito	2000	UF	ORGANIC	Dimethylphenol[2,4-]	1		1		1	1				Perennial	850	µg/L	N
Starmers above Pajarito	2000	UF	ORGANIC	Di-n-butylphthalate	1		1		1	1				Perennial	4500	µg/L	N
Starmers above Pajarito	2000	UF	ORGANIC	Dinitro-2-methylphenol[4,6-]	1		1		1	1				Perennial	280	µg/L	N
Starmers above Pajarito	2000	UF	ORGANIC	Dinitrophenol[2,4-]	1		1		1	1				Perennial	5300	µg/L	N
Starmers above Pajarito	2000	UF	ORGANIC	Dinitrotoluene[2,4-]	1		1		1	1				Perennial	34	µg/L	N
Starmers above Pajarito	2000	UF	ORGANIC	Fluoranthene	1		1		1	1				Perennial	140	µg/L	N
Starmers above Pajarito	2000	UF	ORGANIC	Fluorene	1		1		1	1				Perennial	5300	µg/L	N
Starmers above Pajarito	2000	UF	ORGANIC	Hexachlorobenzene	1		1		1	1				Perennial	0.0029	µg/L	N
Starmers above Pajarito	2000	UF	ORGANIC	Hexachlorobutadiene	1		1		1	1				Perennial	180	µg/L	N

Location ID	Year	Field Prep	RFI Class	Analyte Name	Number of Analyses	Detected	Nondetect	Count Detect > Wsal	Count Nd > Wsal	Total Analyses > Wsal	Average	Min	Max	Stream Type	Wsal	Units	Ever Detected?
Starmers above Pajarito	2000	UF	ORGANIC	Hexachlorocyclopentadiene	1		1		1	1				Perennial	17000	µg/L	N
Starmers above Pajarito	2000	UF	ORGANIC	Hexachloroethane	1		1		1	1				Perennial	33	µg/L	N
Starmers above Pajarito	2000	UF	ORGANIC	Indeno[1,2,3-cd]pyrene	1		1		1	1				Perennial	0.18	µg/L	N
Starmers above Pajarito	2000	UF	ORGANIC	Isophorone	1		1		1	1				Perennial	9600	µg/L	N
Starmers above Pajarito	2000	UF	ORGANIC	Nitrobenzene	1		1		1	1				Perennial	690	µg/L	N
Starmers above Pajarito	2000	UF	ORGANIC	Nitrosodimethylamine[N-]	1		1		1	1				Perennial	30	µg/L	N
Starmers above Pajarito	2000	UF	ORGANIC	Nitroso-di-n-propylamine[N-]	1		1		1	1				Perennial	5.1	µg/L	N
Starmers above Pajarito	2000	UF	ORGANIC	Nitrosodiphenylamine[N-]	1		1		1	1				Perennial	60	µg/L	N
Starmers above Pajarito	2000	UF	ORGANIC	Oxybis[1-chloropropane][2,2'-]	1		1		1	1				Perennial	65000	µg/L	N
Starmers above Pajarito	2000	UF	ORGANIC	Pentachlorophenol	1		1		1	1				Perennial	15	µg/L	N
Starmers above Pajarito	2000	UF	ORGANIC	Phenol	1		1		1	1				Perennial	1700000	µg/L	N
Starmers above Pajarito	2000	UF	ORGANIC	Pyrene	1		1		1	1				Perennial	4000	µg/L	N
Starmers above Pajarito	2000	UF	ORGANIC	Trichlorobenzene[1,2,4-]	1		1		1	1				Perennial	940	µg/L	N
Starmers above Pajarito	2000	UF	ORGANIC	Trichlorophenol[2,4,6-]	1		1		1	1				Perennial	24	ug/L	N
Starmers above Pajarito	2000	UF	RAD	Gross alpha	1	1		1		1	95.7	95.7	95.7	Perennial	15	pCi/L	Y
Starmers above Pajarito	2000	UF	RAD	Tritium	1		1		1	1				Perennial	20000	pCi/L	N
Starmers above Pajarito	2002	UF	INORGANIC	Arsenic	1	1		1		1	12	12	12	Perennial	9	µg/L	Y
Starmers above Pajarito	2002	UF	INORGANIC	Cadmium	1	1		1		1	7.14	7.14	7.14	Perennial	0.28	µg/L	Y
Starmers above Pajarito	2002	UF	INORGANIC	Cyanide [Total]	1	1		1		1	6.28	6.28	6.28	Perennial	0.0636	µg/L	Y
Starmers above Pajarito	2002	UF	INORGANIC	Lead	1	1		1		1	85	85	85	Perennial	3.2	µg/L	Y
Starmers above Pajarito	2002	UF	INORGANIC	Magnesium	1	1		1		1	18900	18900	18900	Perennial	0.0636	µg/L	Y
Starmers above Pajarito	2002	UF	INORGANIC	Mercury	1		1		1	1				Perennial	0.77	µg/L	N
Starmers above Pajarito	2002	UF	INORGANIC	Selenium	1	1		1		1	2.44	2.44	2.44	Perennial	5	µg/L	Y
Starmers above Pajarito	2002	UF	INORGANIC	Silver	1	1		1		1	5.72	5.72	5.72	Perennial	3.8	µg/L	Y
Starmers above Pajarito	2003	F	INORGANIC	Chemical Oxygen Demand	1	1		1		1	54000	54000	54000	Perennial	120	µg/L	Y
Starmers above Pajarito	2003	F	INORGANIC	Nitrate-Nitrite as Nitrogen	1	1		1		1	930	930	930	Perennial	132	µg/L	Y
Starmers above Pajarito	2003	UF	INORGANIC	Cyanide [Total]	2	2		2		2	7.785	3.37	12.2	Perennial	0.0636	µg/L	Y
Starmers above Pajarito	2003	UF	INORGANIC	Cyanide, Amenable to Chlorination	1		1		1	1				Perennial	0.0052	µg/L	N
Starmers above Pajarito	2005	UF	INORGANIC	Aluminum	1	1		1		1	58600	58600	58600	Perennial	87	µg/L	Y

Location ID	Year	Field Prep	RFI Class	Analyte Name	Number of Analyses	Detected	Nondetect	Count Detect > Wsal	Count Nd > Wsal	Total Analyses > Wsal	Average	Min	Max	Stream Type	Wsal	Units	Ever Detected?
Starmers above Pajarito	2005	UF	INORGANIC	Antimony	1	1		1		1	1.1	1.1	1.1	Perennial	640	µg/L	Y
Starmers above Pajarito	2005	UF	INORGANIC	Arsenic	1	1		1		1	13.7	13.7	13.7	Perennial	9	µg/L	Y
Starmers above Pajarito	2005	UF	INORGANIC	Cadmium	1	1		1		1	3.6	3.6	3.6	Perennial	0.28	µg/L	Y
Starmers above Pajarito	2005	UF	INORGANIC	Chromium	1	1		1		1	37.4	37.4	37.4	Perennial	77	µg/L	Y
Starmers above Pajarito	2005	UF	INORGANIC	Cobalt	1	1		1		1	43	43	43	Perennial	1000	µg/L	Y
Starmers above Pajarito	2005	UF	INORGANIC	Copper	1	1		1		1	53.4	53.4	53.4	Perennial	9.4	µg/L	Y
Starmers above Pajarito	2005	UF	INORGANIC	Lead	1	1		1		1	86.1	86.1	86.1	Perennial	3.2	µg/L	Y
Starmers above Pajarito	2005	UF	INORGANIC	Magnesium	1	1		1		1	12000	12000	12000	Perennial	0.0636	µg/L	Y
Starmers above Pajarito	2005	UF	INORGANIC	Mercury	1	1		1		1	0.13	0.13	0.13	Perennial	0.77	µg/L	Y
Starmers above Pajarito	2005	UF	INORGANIC	Nickel	1	1		1		1	37.4	37.4	37.4	Perennial	52	µg/L	Y
Starmers above Pajarito	2005	UF	INORGANIC	Selenium	1		1		1	1				Perennial	5	µg/L	N
Starmers above Pajarito	2005	UF	INORGANIC	Silver	1	1		1		1	121	121	121	Perennial	3.8	µg/L	Y
Starmers above Pajarito	2005	UF	INORGANIC	Thallium	1	1		1		1	0.69	0.69	0.69	Perennial	6.3	µg/L	Y
Starmers above Pajarito	2005	UF	INORGANIC	Vanadium	1	1		1		1	110	110	110	Perennial	100	µg/L	Y
Starmers above Pajarito	2005	UF	INORGANIC	Zinc	1	1		1		1	443	443	443	Perennial	120	µg/L	Y
Starmers above Pajarito	2006	UF	INORGANIC	Aluminum	1	1		1		1	38000	38000	38000	Perennial	87	µg/L	Y
Starmers above Pajarito	2006	UF	INORGANIC	Ammonia as Nitrogen	1	1		1		1	70	70	70	Perennial	8.19	µg/L	Y
Starmers above Pajarito	2006	UF	INORGANIC	Arsenic	1	1		1		1	8.8	8.8	8.8	Perennial	9	µg/L	Y
Starmers above Pajarito	2006	UF	INORGANIC	Cadmium	1	1		1		1	1	1	1	Perennial	0.28	µg/L	Y
Starmers above Pajarito	2006	UF	INORGANIC	Chemical Oxygen Demand	1	1		1		1	178000	178000	178000	Perennial	120	µg/L	Y
Starmers above Pajarito	2006	UF	INORGANIC	Chromium	1	1		1		1	16.2	16.2	16.2	Perennial	77	µg/L	Y
Starmers above Pajarito	2006	UF	INORGANIC	Copper	1	1		1		1	24.6	24.6	24.6	Perennial	9.4	µg/L	Y
Starmers above Pajarito	2006	UF	INORGANIC	Cyanide [Total]	1		1		1	1				Perennial	0.0636	µg/L	N
Starmers above Pajarito	2006	UF	INORGANIC	Cyanide, Amenable to Chlorination	1		1		1	1				Perennial	0.0052	µg/L	N
Starmers above Pajarito	2006	UF	INORGANIC	Lead	1	1		1		1	36.2	36.2	36.2	Perennial	3.2	µg/L	Y
Starmers above Pajarito	2006	UF	INORGANIC	Magnesium	1	1		1		1	6900	6900	6900	Perennial	0.0636	µg/L	Y
Starmers above Pajarito	2006	UF	INORGANIC	Mercury	1		1		1	1				Perennial	0.77	µg/L	N
Starmers above Pajarito	2006	UF	INORGANIC	Selenium	1		1		1	1				Perennial	5	µg/L	N
Starmers above Pajarito	2006	UF	INORGANIC	Silver	1	1		1		1	16.6	16.6	16.6	Perennial	3.8	µg/L	Y

Location ID	Year	Field Prep	RFI Class	Analyte Name	Number of Analyses	Detected	Nondetect	Count Detect > Wsal	Count Nd > Wsal	Total Analyses > Wsal	Average	Min	Max	Stream Type	Wsal	Units	Ever Detected?
Starmers above Pajarito	2006	UF	INORGANIC	Thallium	1		1		1	1				Perennial	6.3	µg/L	N
Starmers above Pajarito	2006	UF	INORGANIC	Vanadium	1	1		1		1	50.2	50.2	50.2	Perennial	100	µg/L	Y
Starmers above Pajarito	2006	UF	INORGANIC	Zinc	1	1		1		1	149	149	149	Perennial	120	µg/L	Y
Starmers above Pajarito	2004	UF	INORGANIC	Aluminum	2	2		2		2	77350	70800	83900	Perennial	87	µg/L	Y
Starmers above Pajarito	2004	UF	INORGANIC	Ammonia as Nitrogen	2	2		2		2	214	127	301	Perennial	8.19	µg/L	Y
Starmers above Pajarito	2004	UF	INORGANIC	Antimony	2		2		2	2				Perennial	640	µg/L	N
Starmers above Pajarito	2004	UF	INORGANIC	Arsenic	2	1	1	1	1	2	12.3	12.3	12.3	Perennial	9	µg/L	Y
Starmers above Pajarito	2004	UF	INORGANIC	Boron	2	2		2		2	29.65	29.2	30.1	Perennial	5000	µg/L	Y
Starmers above Pajarito	2004	UF	INORGANIC	Cadmium	2	2		2		2	1.64	1.6	1.68	Perennial	0.28	µg/L	Y
Starmers above Pajarito	2004	UF	INORGANIC	Chemical Oxygen Demand	2	2		2		2	100450	86900	114000	Perennial	120	µg/L	Y
Starmers above Pajarito	2004	UF	INORGANIC	Chromium	2	2		2		2	40.55	38.1	43	Perennial	77	µg/L	Y
Starmers above Pajarito	2004	UF	INORGANIC	Cobalt	2	2		2		2	19.15	17.3	21	Perennial	1000	µg/L	Y
Starmers above Pajarito	2004	UF	INORGANIC	Copper	2	2		2		2	40.45	36.9	44	Perennial	9.4	µg/L	Y
Starmers above Pajarito	2004	UF	INORGANIC	Cyanide [Total]	2	1	1	1	1	2	1.91	1.91	1.91	Perennial	0.0636	µg/L	Y
Starmers above Pajarito	2004	UF	INORGANIC	Cyanide, Amenable to Chlorination	2		2		2	2				Perennial	0.0052	µg/L	N
Starmers above Pajarito	2004	UF	INORGANIC	Lead	2	2		2		2	69.9	65	74.8	Perennial	3.2	µg/L	Y
Starmers above Pajarito	2004	UF	INORGANIC	Magnesium	2	2		2		2	12300	12000	12600	Perennial	0.0636	µg/L	Y
Starmers above Pajarito	2004	UF	INORGANIC	Mercury	2	2		2		2	0.1875	0.175	0.2	Perennial	0.77	µg/L	Y
Starmers above Pajarito	2004	UF	INORGANIC	Nickel	2	2		2		2	33.55	32.6	34.5	Perennial	52	µg/L	Y
Starmers above Pajarito	2004	UF	INORGANIC	Selenium	2		2		2	2				Perennial	5	µg/L	N
Starmers above Pajarito	2004	UF	INORGANIC	Silver	2	2		2		2	11.4	10.1	12.7	Perennial	3.8	µg/L	Y
Starmers above Pajarito	2004	UF	INORGANIC	Thallium	2	2		2		2	1.1825	0.965	1.4	Perennial	6.3	µg/L	Y
Starmers above Pajarito	2004	UF	INORGANIC	Vanadium	2	2		2		2	86.9	80.7	93.1	Perennial	100	µg/L	Y
Starmers above Pajarito	2004	UF	INORGANIC	Zinc	2	2		2		2	250.5	217	284	Perennial	120	µg/L	Y
Starmers above Pajarito	2007	UF	INORGANIC	Aluminum	4	4		4		4	37127.5	6620	69700	Perennial	87	µg/L	Y
Starmers above Pajarito	2007	UF	INORGANIC	Antimony	4		4		4	4				Perennial	640	µg/L	N
Starmers above Pajarito	2007	UF	INORGANIC	Arsenic	4	2	2	2	2	4	10.25	6.8	13.7	Perennial	9	µg/L	Y
Starmers above Pajarito	2007	UF	INORGANIC	Cadmium	4	4		4		4	0.765	0.5	1.3	Perennial	0.28	µg/L	Y
Starmers above Pajarito	2007	UF	INORGANIC	Chromium	4	4		4		4	22.025	3.8	35.2	Perennial	77	µg/L	Y

Location ID	Year	Field Prep	RFI Class	Analyte Name	Number of Analyses	Detected	Nondetect	Count Detect > Wsal	Count Nd > Wsal	Total Analyses > Wsal	Average	Min	Max	Stream Type	Wsal	Units	Ever Detected?
Starmers above Pajarito	2007	UF	INORGANIC	Cobalt	4	4		4		4	15.875	6.2	27.6	Perennial	1000	µg/L	Y
Starmers above Pajarito	2007	UF	INORGANIC	Copper	4	3	1	3	1	4	30.366667	27.2	35.3	Perennial	9.4	µg/L	Y
Starmers above Pajarito	2007	UF	INORGANIC	Cyanide [Total]	3	1	2	1	2	3	3.39	3.39	3.39	Perennial	0.0636	µg/L	Y
Starmers above Pajarito	2007	UF	INORGANIC	Cyanide, Amenable to Chlorination	4		4		4	4				Perennial	0.0052	µg/L	N
Starmers above Pajarito	2007	UF	INORGANIC	Lead	4	4		4		4	40.65	31.3	54.8	Perennial	3.2	µg/L	Y
Starmers above Pajarito	2007	UF	INORGANIC	Magnesium	4	4		4		4	7287.5	3720	10300	Perennial	0.0636	µg/L	Y
Starmers above Pajarito	2007	UF	INORGANIC	Mercury	4	3	1	3	1	4	0.061	0.037	0.09	Perennial	0.77	µg/L	Y
Starmers above Pajarito	2007	UF	INORGANIC	Nickel	4	4		4		4	20.45	13.2	27.6	Perennial	52	µg/L	Y
Starmers above Pajarito	2007	UF	INORGANIC	Selenium	4		4		4	4				Perennial	5	µg/L	N
Starmers above Pajarito	2007	UF	INORGANIC	Silver	4	4		4		4	17.85	4.6	49.1	Perennial	3.8	µg/L	Y
Starmers above Pajarito	2007	UF	INORGANIC	Thallium	4	2	2	2	2	4	0.64	0.47	0.81	Perennial	6.3	µg/L	Y
Starmers above Pajarito	2007	UF	INORGANIC	Vanadium	4	4		4		4	53.175	19.6	76.3	Perennial	100	µg/L	Y
Starmers above Pajarito	2007	UF	INORGANIC	Zinc	4	4		4		4	135.6	67.4	172	Perennial	120	µg/L	Y
Starmers above Pajarito	2007	UF	RAD	Gross alpha	4	4		4		4	41	23.2	62.5	Perennial	15	pCi/L	Y
La Delfe above Pajarito	2002	UF	INORGANIC	Ammonia as Nitrogen	2	1	1	1	1	2	40	40	40	Ephemeral	39.1	µg/L	Y
La Delfe above Pajarito	2002	UF	INORGANIC	Arsenic	2	2		2		2	4.395	2.94	5.85	Ephemeral	9	µg/L	Y
La Delfe above Pajarito	2002	UF	INORGANIC	Cadmium	2	2		2		2	4.425	3.11	5.74	Ephemeral	2.1	µg/L	Y
La Delfe above Pajarito	2002	UF	INORGANIC	Chemical Oxygen Demand	2	2		2		2	276500	177000	376000	Ephemeral	120	µg/L	Y
La Delfe above Pajarito	2002	UF	INORGANIC	Cyanide [Total]	2	2		2		2	12.655	2.41	22.9	Ephemeral	0.0636	µg/L	Y
La Delfe above Pajarito	2002	UF	INORGANIC	Lead	2	2		2		2	37.25	32	42.5	Ephemeral	81.7	µg/L	Y
La Delfe above Pajarito	2002	UF	INORGANIC	Magnesium	2	2		2		2	5885	4670	7100	Ephemeral	0.0636	µg/L	Y
La Delfe above Pajarito	2002	UF	INORGANIC	Mercury	2	1	1	1	1	2	0.183	0.183	0.183	Ephemeral	0.77	µg/L	Y
La Delfe above Pajarito	2002	UF	INORGANIC	Selenium	2		2		2	2				Ephemeral	5	µg/L	N
La Delfe above Pajarito	2002	UF	INORGANIC	Silver	2	1	1	1	1	2	0.818	0.818	0.818	Ephemeral	3.8	µg/L	Y
La Delfe above Pajarito	2002	UF	ORGANIC	RDX	1	1		1		1	1.1	1.1	1.1	Ephemeral	200	µg/L	Y
La Delfe above Pajarito	2002	UF	ORGANIC	Trinitrotoluene[2,4,6-]	1		1		1	1				Ephemeral	20	µg/L	N
La Delfe above Pajarito	2002	UF	RAD	Tritium	1		1		1	1				Ephemeral	20000	pCi/L	N
La Delfe above Pajarito	2005	UF	INORGANIC	Aluminum	4	4		4		4	26317.5	6770	51700	Ephemeral	750	µg/L	Y
La Delfe above Pajarito	2005	UF	INORGANIC	Antimony	4	2	2	2	2	4	0.535	0.52	0.55	Ephemeral	640	µg/L	Y

Location ID	Year	Field Prep	RFI Class	Analyte Name	Number of Analyses	Detected	Nondetect	Count Detect > Wsal	Count Nd > Wsal	Total Analyses > Wsal	Average	Min	Max	Stream Type	Wsal	Units	Ever Detected?
La Delfe above Pajarito	2005	UF	INORGANIC	Arsenic	4	1	3	1	3	4	12.5	12.5	12.5	Ephemeral	9	µg/L	Y
La Delfe above Pajarito	2005	UF	INORGANIC	Cadmium	4	4		4		4	2.9725	0.19	5.8	Ephemeral	2.1	µg/L	Y
La Delfe above Pajarito	2005	UF	INORGANIC	Chromium	4	4		4		4	17.325	3.5	32.9	Ephemeral	580	µg/L	Y
La Delfe above Pajarito	2005	UF	INORGANIC	Cobalt	4	3	1	3	1	4	12.033333	7.1	14.8	Ephemeral	1000	µg/L	Y
La Delfe above Pajarito	2005	UF	INORGANIC	Copper	4	4		4		4	23.975	4.2	43	Ephemeral	14	µg/L	Y
La Delfe above Pajarito	2005	UF	INORGANIC	Lead	4	4		4		4	34.4	5.7	59.8	Ephemeral	81.7	µg/L	Y
La Delfe above Pajarito	2005	UF	INORGANIC	Magnesium	4	4		4		4	5672.5	2030	8640	Ephemeral	0.0636	µg/L	Y
La Delfe above Pajarito	2005	UF	INORGANIC	Mercury	4	4		4		4	0.5075	0.24	0.79	Ephemeral	0.77	µg/L	Y
La Delfe above Pajarito	2005	UF	INORGANIC	Nickel	4	4		4		4	12.75	2.7	20.5	Ephemeral	469	µg/L	Y
La Delfe above Pajarito	2005	UF	INORGANIC	Selenium	4		4		4	4				Ephemeral	5	µg/L	N
La Delfe above Pajarito	2005	UF	INORGANIC	Silver	4	3	1	3	1	4	3.3166667	0.25	5.2	Ephemeral	3.8	µg/L	Y
La Delfe above Pajarito	2005	UF	INORGANIC	Thallium	4	3	1	3	1	4	1.65	0.95	2.3	Ephemeral	6.3	µg/L	Y
La Delfe above Pajarito	2005	UF	INORGANIC	Vanadium	4	4		4		4	38.9	7.1	65.9	Ephemeral	100	µg/L	Y
La Delfe above Pajarito	2005	UF	INORGANIC	Zinc	4	4		4		4	85.65	17.1	137	Ephemeral	120	µg/L	Y
La Delfe above Pajarito	2005	UF	ORGANIC	RDX	4	3	1	3	1	4	1.14	0.6	2.1	Ephemeral	200	µg/L	Y
La Delfe above Pajarito	2005	UF	ORGANIC	Trinitrotoluene[2,4,6-]	4		4		4	4				Ephemeral	20	µg/L	N
La Delfe above Pajarito	2006	UF	INORGANIC	Aluminum	3	3		3		3	26000	18300	38400	Ephemeral	750	µg/L	Y
La Delfe above Pajarito	2006	UF	INORGANIC	Ammonia as Nitrogen	3	3		3		3	74	69	78	Ephemeral	39.1	µg/L	Y
La Delfe above Pajarito	2006	UF	INORGANIC	Arsenic	3	2	1	2	1	3	6.85	6.3	7.4	Ephemeral	9	µg/L	Y
La Delfe above Pajarito	2006	UF	INORGANIC	Cadmium	3	3		3		3	7.8333333	1.9	18.6	Ephemeral	2.1	µg/L	Y
La Delfe above Pajarito	2006	UF	INORGANIC	Chemical Oxygen Demand	3	3		3		3	190333.33	176000	198000	Ephemeral	120	µg/L	Y
La Delfe above Pajarito	2006	UF	INORGANIC	Chromium	3	3		3		3	12.366667	9.7	16	Ephemeral	580	µg/L	Y
La Delfe above Pajarito	2006	UF	INORGANIC	Copper	3	3		3		3	42.166667	17.2	86.9	Ephemeral	14	µg/L	Y
La Delfe above Pajarito	2006	UF	INORGANIC	Cyanide [Total]	3	1	2	1	2	3	2.5	2.5	2.5	Ephemeral	0.0636	µg/L	Y
La Delfe above Pajarito	2006	UF	INORGANIC	Cyanide, Amenable to Chlorination	2		2		2	2				Ephemeral	0.0052	µg/L	N
La Delfe above Pajarito	2006	UF	INORGANIC	Lead	3	3		3		3	50.733333	26.8	93.4	Ephemeral	81.7	µg/L	Y
La Delfe above Pajarito	2006	UF	INORGANIC	Magnesium	3	3		3		3	7153.3333	5090	10400	Ephemeral	0.0636	µg/L	Y
La Delfe above Pajarito	2006	UF	INORGANIC	Mercury	3	1	2	1	2	3	2.2	2.2	2.2	Ephemeral	0.77	µg/L	Y
La Delfe above Pajarito	2006	UF	INORGANIC	Selenium	3		3		3	3				Ephemeral	5	µg/L	N

Location ID	Year	Field Prep	RFI Class	Analyte Name	Number of Analyses	Detected	Nondetect	Count Detect > Wsal	Count Nd > Wsal	Total Analyses > Wsal	Average	Min	Max	Stream Type	Wsal	Units	Ever Detected?
La Delfe above Pajarito	2006	UF	INORGANIC	Silver	3	3		3		3	2.6333333	2	3	Ephemeral	3.8	µg/L	Y
La Delfe above Pajarito	2006	UF	INORGANIC	Thallium	3	1	2	1	2	3	1.1	1.1	1.1	Ephemeral	6.3	µg/L	Y
La Delfe above Pajarito	2006	UF	INORGANIC	Vanadium	3	3		3		3	67.733333	24.4	143	Ephemeral	100	µg/L	Y
La Delfe above Pajarito	2006	UF	INORGANIC	Zinc	3	3		3		3	139.3	69.7	254	Ephemeral	120	µg/L	Y
La Delfe above Pajarito	2006	UF	ORGANIC	RDX	3	2	1	2	1	3	0.89	0.68	1.1	Ephemeral	200	µg/L	Y
La Delfe above Pajarito	2006	UF	ORGANIC	Trinitrotoluene[2,4,6-]	2		2		2	2				Ephemeral	20	µg/L	N
La Delfe above Pajarito	2004	UF	INORGANIC	Aluminum	1	1		1		1	18300	18300	18300	Ephemeral	750	µg/L	Y
La Delfe above Pajarito	2004	UF	INORGANIC	Ammonia as Nitrogen	1	1		1		1	284	284	284	Ephemeral	39.1	µg/L	Y
La Delfe above Pajarito	2004	UF	INORGANIC	Antimony	1		1		1	1				Ephemeral	640	µg/L	N
La Delfe above Pajarito	2004	UF	INORGANIC	Arsenic	1		1		1	1				Ephemeral	9	µg/L	N
La Delfe above Pajarito	2004	UF	INORGANIC	Boron	1	1		1		1	27.4	27.4	27.4	Ephemeral	5000	µg/L	Y
La Delfe above Pajarito	2004	UF	INORGANIC	Cadmium	1	1		1		1	5.03	5.03	5.03	Ephemeral	2.1	µg/L	Y
La Delfe above Pajarito	2004	UF	INORGANIC	Chemical Oxygen Demand	1	1		1		1	336000	336000	336000	Ephemeral	120	µg/L	Y
La Delfe above Pajarito	2004	UF	INORGANIC	Chromium	1		1		1	1				Ephemeral	580	µg/L	N
La Delfe above Pajarito	2004	UF	INORGANIC	Cobalt	1	1		1		1	13.5	13.5	13.5	Ephemeral	1000	µg/L	Y
La Delfe above Pajarito	2004	UF	INORGANIC	Copper	1	1		1		1	26.9	26.9	26.9	Ephemeral	14	µg/L	Y
La Delfe above Pajarito	2004	UF	INORGANIC	Cyanide [Total]	1	1		1		1	3.7	3.7	3.7	Ephemeral	0.0636	µg/L	Y
La Delfe above Pajarito	2004	UF	INORGANIC	Cyanide, Amenable to Chlorination	1		1		1	1				Ephemeral	0.0052	µg/L	N
La Delfe above Pajarito	2004	UF	INORGANIC	Lead	1	1		1		1	64.7	64.7	64.7	Ephemeral	81.7	µg/L	Y
La Delfe above Pajarito	2004	UF	INORGANIC	Magnesium	1	1		1		1	5170	5170	5170	Ephemeral	0.0636	µg/L	Y
La Delfe above Pajarito	2004	UF	INORGANIC	Mercury	1	1		1		1	0.183	0.183	0.183	Ephemeral	0.77	µg/L	Y
La Delfe above Pajarito	2004	UF	INORGANIC	Nickel	1	1		1		1	13.2	13.2	13.2	Ephemeral	469	µg/L	Y
La Delfe above Pajarito	2004	UF	INORGANIC	Selenium	1		1		1	1				Ephemeral	5	µg/L	N
La Delfe above Pajarito	2004	UF	INORGANIC	Silver	1		1		1	1				Ephemeral	3.8	µg/L	N
La Delfe above Pajarito	2004	UF	INORGANIC	Thallium	1	1		1		1	0.596	0.596	0.596	Ephemeral	6.3	µg/L	Y
La Delfe above Pajarito	2004	UF	INORGANIC	Vanadium	1	1		1		1	38	38	38	Ephemeral	100	µg/L	Y
La Delfe above Pajarito	2004	UF	INORGANIC	Zinc	1	1		1		1	128	128	128	Ephemeral	120	µg/L	Y
La Delfe above Pajarito	2004	UF	ORGANIC	RDX	1		1		1	1				Ephemeral	200	µg/L	N
La Delfe above Pajarito	2004	UF	ORGANIC	Trinitrotoluene[2,4,6-]	1		1		1	1				Ephemeral	20	µg/L	N

Location ID	Year	Field Prep	RFI Class	Analyte Name	Number of Analyses	Detected	Nondetect	Count Detect > Wsal	Count Nd > Wsal	Total Analyses > Wsal	Average	Min	Max	Stream Type	Wsal	Units	Ever Detected?
La Delfe above Pajarito	2007	UF	INORGANIC	Aluminum	4	4		4		4	25272.5	3490	40900	Ephemeral	750	µg/L	Y
La Delfe above Pajarito	2007	UF	INORGANIC	Antimony	4		4		4	4				Ephemeral	640	µg/L	N
La Delfe above Pajarito	2007	UF	INORGANIC	Arsenic	4	2	2	2	2	4	10.9	10.1	11.7	Ephemeral	9	µg/L	Y
La Delfe above Pajarito	2007	UF	INORGANIC	Cadmium	4	4		4		4	2.775	1.2	4	Ephemeral	2.1	µg/L	Y
La Delfe above Pajarito	2007	UF	INORGANIC	Chromium	4	4		4		4	14.025	1.3	22.2	Ephemeral	580	µg/L	Y
La Delfe above Pajarito	2007	UF	INORGANIC	Cobalt	4	4		4		4	9.45	5	15.1	Ephemeral	1000	µg/L	Y
La Delfe above Pajarito	2007	UF	INORGANIC	Copper	4	4		4		4	22.875	11.6	32.2	Ephemeral	14	µg/L	Y
La Delfe above Pajarito	2007	UF	INORGANIC	Cyanide [Total]	2		2		2	2				Ephemeral	0.0636	µg/L	N
La Delfe above Pajarito	2007	UF	INORGANIC	Cyanide, Amenable to Chlorination	3		3		3	3				Ephemeral	0.0052	µg/L	N
La Delfe above Pajarito	2007	UF	INORGANIC	Lead	4	4		4		4	42	16.1	57.1	Ephemeral	81.7	µg/L	Y
La Delfe above Pajarito	2007	UF	INORGANIC	Magnesium	4	4		4		4	6122.5	3330	8070	Ephemeral	0.0636	µg/L	Y
La Delfe above Pajarito	2007	UF	INORGANIC	Mercury	4	4		4		4	0.37875	0.035	0.66	Ephemeral	0.77	µg/L	Y
La Delfe above Pajarito	2007	UF	INORGANIC	Nickel	4	4		4		4	13.075	3.6	18.9	Ephemeral	469	µg/L	Y
La Delfe above Pajarito	2007	UF	INORGANIC	Selenium	4	2	2	2	2	4	1.45	1.3	1.6	Ephemeral	5	µg/L	Y
La Delfe above Pajarito	2007	UF	INORGANIC	Silver	4	3	1	3	1	4	3.3	2.6	3.9	Ephemeral	3.8	µg/L	Y
La Delfe above Pajarito	2007	UF	INORGANIC	Thallium	4	2	2	2	2	4	1.65	1.5	1.8	Ephemeral	6.3	µg/L	Y
La Delfe above Pajarito	2007	UF	INORGANIC	Vanadium	4	4		4		4	35.575	13.4	55.9	Ephemeral	100	µg/L	Y
La Delfe above Pajarito	2007	UF	INORGANIC	Zinc	4	4		4		4	92.475	38.2	133	Ephemeral	120	µg/L	Y
La Delfe above Pajarito	2007	UF	ORGANIC	RDX	4	2	2	2	2	4	1.0195	0.899	1.14	Ephemeral	200	µg/L	Y
La Delfe above Pajarito	2007	UF	ORGANIC	Trinitrotoluene[2,4,6-]	4		4		4	4				Ephemeral	20	µg/L	N
La Delfe above Pajarito	2007	UF	RAD	Gross alpha	4	4		4		4	36.85	12.3	63	Ephemeral	15	pCi/L	Y
Pajarito above Twomile	2002	UF	INORGANIC	Ammonia as Nitrogen	1	1		1		1	550	550	550	Ephemeral	39.1	µg/L	Y
Pajarito above Twomile	2002	UF	INORGANIC	Arsenic	1	1		1		1	9.86	9.86	9.86	Ephemeral	9	µg/L	Y
Pajarito above Twomile	2002	UF	INORGANIC	Cadmium	1	1		1		1	23.9	23.9	23.9	Ephemeral	2.1	µg/L	Y
Pajarito above Twomile	2002	UF	INORGANIC	Chemical Oxygen Demand	1	1		1		1	438000	438000	438000	Ephemeral	120	µg/L	Y
Pajarito above Twomile	2002	UF	INORGANIC	Cyanide [Total]	1	1		1		1	9.76	9.76	9.76	Ephemeral	0.0636	µg/L	Y
Pajarito above Twomile	2002	UF	INORGANIC	Lead	1	1		1		1	224	224	224	Ephemeral	81.7	µg/L	Y
Pajarito above Twomile	2002	UF	INORGANIC	Magnesium	1	1		1		1	16100	16100	16100	Ephemeral	0.0636	µg/L	Y
Pajarito above Twomile	2002	UF	INORGANIC	Mercury	1		1		1	1				Ephemeral	0.77	µg/L	N

Location ID	Year	Field Prep	RFI Class	Analyte Name	Number of Analyses	Detected	Nondetect	Count Detect > Wsal	Count Nd > Wsal	Total Analyses > Wsal	Average	Min	Max	Stream Type	Wsal	Units	Ever Detected?
Pajarito above Twomile	2002	UF	INORGANIC	Selenium	1	1		1		1	5.72	5.72	5.72	Ephemeral	5	µg/L	Y
Pajarito above Twomile	2002	UF	INORGANIC	Silver	1	1		1		1	0.912	0.912	0.912	Ephemeral	3.8	µg/L	Y
Pajarito above Twomile	2005	UF	INORGANIC	Aluminum	2	2		2		2	181400	12800	350000	Ephemeral	750	µg/L	Y
Pajarito above Twomile	2005	UF	INORGANIC	Antimony	2	1	1	1	1	2	0.84	0.84	0.84	Ephemeral	640	µg/L	Y
Pajarito above Twomile	2005	UF	INORGANIC	Arsenic	2	1	1	1	1	2	67.1	67.1	67.1	Ephemeral	9	µg/L	Y
Pajarito above Twomile	2005	UF	INORGANIC	Cadmium	2	2		2		2	19.95	11	28.9	Ephemeral	2.1	µg/L	Y
Pajarito above Twomile	2005	UF	INORGANIC	Chromium	2	2		2		2	146.85	11.7	282	Ephemeral	580	µg/L	Y
Pajarito above Twomile	2005	UF	INORGANIC	Cobalt	2	2		2		2	94.4	50.8	138	Ephemeral	1000	µg/L	Y
Pajarito above Twomile	2005	UF	INORGANIC	Copper	2	2		2		2	358.3	74.6	642	Ephemeral	14	µg/L	Y
Pajarito above Twomile	2005	UF	INORGANIC	Lead	2	2		2		2	197.35	76.7	318	Ephemeral	81.7	µg/L	Y
Pajarito above Twomile	2005	UF	INORGANIC	Magnesium	2	2		2		2	32850	10400	55300	Ephemeral	0.0636	µg/L	Y
Pajarito above Twomile	2005	UF	INORGANIC	Mercury	2	2		2		2	0.188	0.066	0.31	Ephemeral	0.77	µg/L	Y
Pajarito above Twomile	2005	UF	INORGANIC	Nickel	2	2		2		2	303.5	118	489	Ephemeral	469	µg/L	Y
Pajarito above Twomile	2005	UF	INORGANIC	Selenium	2	1	1	1	1	2	3.8	3.8	3.8	Ephemeral	5	µg/L	Y
Pajarito above Twomile	2005	UF	INORGANIC	Silver	2	1	1	1	1	2	74.3	74.3	74.3	Ephemeral	3.8	µg/L	Y
Pajarito above Twomile	2005	UF	INORGANIC	Thallium	2	1	1	1	1	2	4.8	4.8	4.8	Ephemeral	6.3	µg/L	Y
Pajarito above Twomile	2005	UF	INORGANIC	Vanadium	2	2		2		2	270.95	88.9	453	Ephemeral	100	µg/L	Y
Pajarito above Twomile	2005	UF	INORGANIC	Zinc	2	2		2		2	811	392	1230	Ephemeral	120	µg/L	Y
Pajarito above Twomile	2005	UF	RAD	Gross alpha	3	3		3		3	84.233333	37.6	119	Ephemeral	15	pCi/L	Y
Pajarito above Twomile	2005	UF	RAD	Tritium	1		1		1	1				Ephemeral	20000	pCi/L	N
Pajarito above Twomile	2006	UF	INORGANIC	Aluminum	3	3		3		3	174533.33	75600	295000	Ephemeral	750	µg/L	Y
Pajarito above Twomile	2006	UF	INORGANIC	Ammonia as Nitrogen	3	3		3		3	405.333333	229	581	Ephemeral	39.1	µg/L	Y
Pajarito above Twomile	2006	UF	INORGANIC	Arsenic	3	3		3		3	55.3	19.5	113	Ephemeral	9	µg/L	Y
Pajarito above Twomile	2006	UF	INORGANIC	Cadmium	3	3		3		3	14.733333	11	20.8	Ephemeral	2.1	µg/L	Y
Pajarito above Twomile	2006	UF	INORGANIC	Chemical Oxygen Demand	3	3		3		3	420333.33	190000	715000	Ephemeral	120	µg/L	Y
Pajarito above Twomile	2006	UF	INORGANIC	Chromium	3	3		3		3	96.266667	21.7	196	Ephemeral	580	µg/L	Y
Pajarito above Twomile	2006	UF	INORGANIC	Copper	3	3		3		3	501.66667	307	797	Ephemeral	14	µg/L	Y
Pajarito above Twomile	2006	UF	INORGANIC	Cyanide [Total]	3	3		3		3	3.3166667	2.11	4.7	Ephemeral	0.0636	µg/L	Y
Pajarito above Twomile	2006	UF	INORGANIC	Lead	3	3		3		3	256.333333	122	423	Ephemeral	81.7	µg/L	Y

Location ID	Year	Field Prep	RFI Class	Analyte Name	Number of Analyses	Detected	Nondetect	Count Detect > Wsal	Count Nd > Wsal	Total Analyses > Wsal	Average	Min	Max	Stream Type	Wsal	Units	Ever Detected?
Pajarito above Twomile	2006	UF	INORGANIC	Magnesium	3	3		3		3	31333.333	17600	48800	Ephemeral	0.0636	µg/L	Y
Pajarito above Twomile	2006	UF	INORGANIC	Mercury	3		3		3	3				Ephemeral	0.77	µg/L	N
Pajarito above Twomile	2006	UF	INORGANIC	Selenium	3	1	2	1	2	3	4.2	4.2	4.2	Ephemeral	5	µg/L	Y
Pajarito above Twomile	2006	UF	INORGANIC	Silver	3	3		3		3	41.333333	5.9	88.6	Ephemeral	3.8	µg/L	Y
Pajarito above Twomile	2006	UF	INORGANIC	Thallium	3	2	1	2	1	3	2.71	0.62	4.8	Ephemeral	6.3	µg/L	Y
Pajarito above Twomile	2006	UF	INORGANIC	Vanadium	3	3		3		3	229.66667	127	354	Ephemeral	100	µg/L	Y
Pajarito above Twomile	2006	UF	INORGANIC	Zinc	3	3		3		3	828.66667	636	1130	Ephemeral	120	µg/L	Y
Pajarito above Twomile	2006	UF	ORGANIC	RDX	1		1		1	1				Ephemeral	200	µg/L	N
Pajarito above Twomile	2006	UF	ORGANIC	Trinitrotoluene[2,4,6-]	2		2		2	2				Ephemeral	20	µg/L	N
Pajarito above Twomile	2006	UF	RAD	Gross alpha	3	3		3		3	2302.3333	152	6420	Ephemeral	15	pCi/L	Y
Pajarito above Twomile	2006	UF	RAD	Radium-226	3	3		3		3	11.05	5.18	19.6	Ephemeral	30	pCi/L	Y
Pajarito above Twomile	2007	UF	INORGANIC	Aluminum	4	4		4		4	94575	11300	250000	Ephemeral	750	µg/L	Y
Pajarito above Twomile	2007	UF	INORGANIC	Antimony	4		4		4	4				Ephemeral	640	µg/L	N
Pajarito above Twomile	2007	UF	INORGANIC	Arsenic	4	4		4		4	20.575	6	47.1	Ephemeral	9	µg/L	Y
Pajarito above Twomile	2007	UF	INORGANIC	Cadmium	4	4		4		4	10.375	2.6	18.4	Ephemeral	2.1	µg/L	Y
Pajarito above Twomile	2007	UF	INORGANIC	Chromium	4	4		4		4	84.925	33.4	179	Ephemeral	580	µg/L	Y
Pajarito above Twomile	2007	UF	INORGANIC	Cobalt	4	4		4		4	40.25	8.9	91.7	Ephemeral	1000	µg/L	Y
Pajarito above Twomile	2007	UF	INORGANIC	Copper	4	4		4		4	229.375	58.5	454	Ephemeral	14	µg/L	Y
Pajarito above Twomile	2007	UF	INORGANIC	Cyanide [Total]	2	1	1	1	1	2	3.08	3.08	3.08	Ephemeral	0.0636	µg/L	Y
Pajarito above Twomile	2007	UF	INORGANIC	Cyanide, Amenable to Chlorination	3		3		3	3				Ephemeral	0.0052	µg/L	N
Pajarito above Twomile	2007	UF	INORGANIC	Lead	4	4		4		4	127.875	50	231	Ephemeral	81.7	µg/L	Y
Pajarito above Twomile	2007	UF	INORGANIC	Magnesium	4	4		4		4	18087.5	5470	41900	Ephemeral	0.0636	µg/L	Y
Pajarito above Twomile	2007	UF	INORGANIC	Mercury	4	3	1	3	1	4	0.22	0.11	0.3	Ephemeral	0.77	µg/L	Y
Pajarito above Twomile	2007	UF	INORGANIC	Nickel	4	4		4		4	177.65	54.2	339	Ephemeral	469	µg/L	Y
Pajarito above Twomile	2007	UF	INORGANIC	Selenium	4	1	3	1	3	4	3.3	3.3	3.3	Ephemeral	5	µg/L	Y
Pajarito above Twomile	2007	UF	INORGANIC	Silver	4	4		4		4	44.35	12.7	114	Ephemeral	3.8	µg/L	Y
Pajarito above Twomile	2007	UF	INORGANIC	Thallium	4	3	1	3	1	4	2.066667	0.8	3.6	Ephemeral	6.3	µg/L	Y
Pajarito above Twomile	2007	UF	INORGANIC	Vanadium	4	4		4		4	124.475	23.3	294	Ephemeral	100	µg/L	Y
Pajarito above Twomile	2007	UF	INORGANIC	Zinc	4	4		4		4	360.875	74.5	893	Ephemeral	120	µg/L	Y

Location ID	Year	Field Prep	RFI Class	Analyte Name	Number of Analyses	Detected	Nondetect	Count Detect > Wsal	Count Nd > Wsal	Total Analyses > Wsal	Average	Min	Max	Stream Type	Wsal	Units	Ever Detected?
Pajarito above Twomile	2007	UF	ORGANIC	RDX	3		3		3	3				Ephemeral	200	µg/L	N
Pajarito above Twomile	2007	UF	ORGANIC	Trinitrotoluene[2,4,6-]	3		3		3	3				Ephemeral	20	µg/L	N
Pajarito above Twomile	2007	UF	RAD	Gross alpha	4	4		4		4	203.4	55.6	323	Ephemeral	15	pCi/L	Y
Pajarito above Twomile	2007	UF	RAD	Radium-226	1	1		1		1	10.3	10.3	10.3	Ephemeral	30	pCi/L	Y
Pajarito above Twomile	2007	UF	RAD	Tritium	1		1		1	1				Ephemeral	20000	pCi/L	N
Twomile above Pajarito	2005	UF	INORGANIC	Aluminum	4	4		4		4	139200	24400	364000	Ephemeral	750	µg/L	Y
Twomile above Pajarito	2005	UF	INORGANIC	Antimony	4	2	2	2	2	4	1.035	0.97	1.1	Ephemeral	640	µg/L	Y
Twomile above Pajarito	2005	UF	INORGANIC	Arsenic	4	4		4		4	37.225	8.8	96.1	Ephemeral	9	µg/L	Y
Twomile above Pajarito	2005	UF	INORGANIC	Cadmium	4	4		4		4	6.35	1.1	13	Ephemeral	2.1	µg/L	Y
Twomile above Pajarito	2005	UF	INORGANIC	Chromium	4	4		4		4	100.925	23.8	262	Ephemeral	580	µg/L	Y
Twomile above Pajarito	2005	UF	INORGANIC	Cobalt	4	4		4		4	58.6	9.7	127	Ephemeral	1000	µg/L	Y
Twomile above Pajarito	2005	UF	INORGANIC	Copper	4	4		4		4	136.5	31.3	313	Ephemeral	14	µg/L	Y
Twomile above Pajarito	2005	UF	INORGANIC	Lead	4	4		4		4	263.5	70	552	Ephemeral	81.7	µg/L	Y
Twomile above Pajarito	2005	UF	INORGANIC	Magnesium	4	4		4		4	25572.5	6490	62800	Ephemeral	0.0636	µg/L	Y
Twomile above Pajarito	2005	UF	INORGANIC	Mercury	4	4		4		4	0.155	0.08	0.2	Ephemeral	0.77	µg/L	Y
Twomile above Pajarito	2005	UF	INORGANIC	Nickel	4	4		4		4	75.5	17.8	190	Ephemeral	469	µg/L	Y
Twomile above Pajarito	2005	UF	INORGANIC	Selenium	4	1	3	1	3	4	5.4	5.4	5.4	Ephemeral	5	µg/L	Y
Twomile above Pajarito	2005	UF	INORGANIC	Silver	4	3	1	3	1	4	2.3166667	0.55	5.1	Ephemeral	3.8	µg/L	Y
Twomile above Pajarito	2005	UF	INORGANIC	Thallium	4	3	1	3	1	4	2.14	0.42	4.4	Ephemeral	6.3	µg/L	Y
Twomile above Pajarito	2005	UF	INORGANIC	Vanadium	4	4		4		4	188.625	42.7	453	Ephemeral	100	µg/L	Y
Twomile above Pajarito	2005	UF	INORGANIC	Zinc	4	4		4		4	994	178	2000	Ephemeral	120	µg/L	Y
Twomile above Pajarito	2005	UF	ORGANIC	Aroclor-1016	2		2		2	2				Ephemeral	0.00064	µg/L	N
Twomile above Pajarito	2005	UF	ORGANIC	Aroclor-1221	2		2		2	2				Ephemeral	0.00064	µg/L	N
Twomile above Pajarito	2005	UF	ORGANIC	Aroclor-1232	2		2		2	2				Ephemeral	0.00064	µg/L	N
Twomile above Pajarito	2005	UF	ORGANIC	Aroclor-1242	2		2		2	2				Ephemeral	0.00064	µg/L	N
Twomile above Pajarito	2005	UF	ORGANIC	Aroclor-1248	2		2		2	2				Ephemeral	0.00064	µg/L	N
Twomile above Pajarito	2005	UF	ORGANIC	Aroclor-1254	2		2		2	2				Ephemeral	0.00064	µg/L	N
Twomile above Pajarito	2005	UF	ORGANIC	Aroclor-1260	2		2		2	2				Ephemeral	0.00064	µg/L	N
Twomile above Pajarito	2005	UF	ORGANIC	Aroclor-1262	1		1		1	1				Ephemeral	0.00064	µg/L	N

Location ID	Year	Field Prep	RFI Class	Analyte Name	Number of Analyses	Detected	Nondetect	Count Detect > Wsal	Count Nd > Wsal	Total Analyses > Wsal	Average	Min	Max	Stream Type	Wsal	Units	Ever Detected?
Twomile above Pajarito	2005	UF	ORGANIC	RDX	1		1		1	1				Ephemeral	200	µg/L	N
Twomile above Pajarito	2005	UF	ORGANIC	Tetrachlorodibenzodioxin[2,3,7,8-]	2		2		2	2				Ephemeral	5.1E-08	µg/L	N
Twomile above Pajarito	2005	UF	ORGANIC	Trinitrotoluene[2,4,6-]	1		1		1	1				Ephemeral	20	µg/L	N
Twomile above Pajarito	2006	UF	INORGANIC	Aluminum	4	4		4		4	63825	43000	95200	Ephemeral	750	µg/L	Y
Twomile above Pajarito	2006	UF	INORGANIC	Ammonia as Nitrogen	4	4		4		4	282.5	87	647	Ephemeral	39.1	µg/L	Y
Twomile above Pajarito	2006	UF	INORGANIC	Arsenic	4	4		4		4	21.4	11.3	31.6	Ephemeral	9	µg/L	Y
Twomile above Pajarito	2006	UF	INORGANIC	Cadmium	4	4		4		4	4.375	2.8	6.6	Ephemeral	2.1	µg/L	Y
Twomile above Pajarito	2006	UF	INORGANIC	Chemical Oxygen Demand	4	4		4		4	673750	116000	1650000	Ephemeral	120	µg/L	Y
Twomile above Pajarito	2006	UF	INORGANIC	Chromium	4	3	1	3	1	4	41	17.6	67.4	Ephemeral	580	µg/L	Y
Twomile above Pajarito	2006	UF	INORGANIC	Copper	4	4		4		4	75.975	45.2	104	Ephemeral	14	µg/L	Y
Twomile above Pajarito	2006	UF	INORGANIC	Cyanide [Total]	4	3	1	3	1	4	6.7666667	4.9	10.3	Ephemeral	0.0636	µg/L	Y
Twomile above Pajarito	2006	UF	INORGANIC	Cyanide, Amenable to Chlorination	3		3		3	3				Ephemeral	0.0052	µg/L	N
Twomile above Pajarito	2006	UF	INORGANIC	Lead	4	4		4		4	201.225	85.9	283	Ephemeral	81.7	µg/L	Y
Twomile above Pajarito	2006	UF	INORGANIC	Magnesium	4	4		4		4	14300	8800	21000	Ephemeral	0.0636	µg/L	Y
Twomile above Pajarito	2006	UF	INORGANIC	Mercury	4	1	3	1	3	4	0.1	0.1	0.1	Ephemeral	0.77	µg/L	Y
Twomile above Pajarito	2006	UF	INORGANIC	Selenium	4		4		4	4				Ephemeral	5	µg/L	N
Twomile above Pajarito	2006	UF	INORGANIC	Silver	4	3	1	3	1	4	0.6766667	0.23	1.1	Ephemeral	3.8	µg/L	Y
Twomile above Pajarito	2006	UF	INORGANIC	Thallium	4	2	2	2	2	4	1.235	0.47	2	Ephemeral	6.3	µg/L	Y
Twomile above Pajarito	2006	UF	INORGANIC	Vanadium	4	4		4		4	93.6	61.7	133	Ephemeral	100	µg/L	Y
Twomile above Pajarito	2006	UF	INORGANIC	Zinc	4	4		4		4	482.75	280	677	Ephemeral	120	µg/L	Y
Twomile above Pajarito	2006	UF	ORGANIC	Aroclor-1016	4		4		4	4				Ephemeral	0.00064	µg/L	N
Twomile above Pajarito	2006	UF	ORGANIC	Aroclor-1221	4		4		4	4				Ephemeral	0.00064	µg/L	N
Twomile above Pajarito	2006	UF	ORGANIC	Aroclor-1232	4		4		4	4				Ephemeral	0.00064	µg/L	N
Twomile above Pajarito	2006	UF	ORGANIC	Aroclor-1242	4		4		4	4				Ephemeral	0.00064	µg/L	N
Twomile above Pajarito	2006	UF	ORGANIC	Aroclor-1248	4		4		4	4				Ephemeral	0.00064	µg/L	N
Twomile above Pajarito	2006	UF	ORGANIC	Aroclor-1254	4		4		4	4				Ephemeral	0.00064	µg/L	N
Twomile above Pajarito	2006	UF	ORGANIC	Aroclor-1260	4		4		4	4				Ephemeral	0.00064	µg/L	N
Twomile above Pajarito	2006	UF	ORGANIC	Aroclor-1262	4		4		4	4				Ephemeral	0.00064	µg/L	N
Twomile above Pajarito	2006	UF	ORGANIC	RDX	2		2		2	2				Ephemeral	200	µg/L	N

Location ID	Year	Field Prep	RFI Class	Analyte Name	Number of Analyses	Detected	Nondetect	Count Detect > Wsal	Count Nd > Wsal	Total Analyses > Wsal	Average	Min	Max	Stream Type	Wsal	Units	Ever Detected?
Twomile above Pajarito	2006	UF	ORGANIC	Tetrachlorodibenzodioxin[2,3,7,8-]	1		1		1	1				Ephemeral	5.1E-08	µg/L	N
Twomile above Pajarito	2006	UF	ORGANIC	Trinitrotoluene[2,4,6-]	2		2		2	2				Ephemeral	20	µg/L	N
Twomile above Pajarito	2006	UF	RAD	Gross alpha	3	3		3		3	225.6	59.8	507	Ephemeral	15	pCi/L	Y
Twomile above Pajarito	2006	UF	RAD	Radium-226	3	3		3		3	9.61	4.83	13.5	Ephemeral	30	pCi/L	Y
Twomile above Pajarito	2006	UF	RAD	Tritium	2		2		2	2				Ephemeral	20000	pCi/L	N
Twomile above Pajarito	2004	UF	INORGANIC	Aluminum	2	2		2		2	118350	75700	161000	Ephemeral	750	µg/L	Y
Twomile above Pajarito	2004	UF	INORGANIC	Ammonia as Nitrogen	2	2		2		2	832.5	722	943	Ephemeral	39.1	µg/L	Y
Twomile above Pajarito	2004	UF	INORGANIC	Antimony	2		2		2	2				Ephemeral	640	µg/L	N
Twomile above Pajarito	2004	UF	INORGANIC	Arsenic	2	2		2		2	36	26.1	45.9	Ephemeral	9	µg/L	Y
Twomile above Pajarito	2004	UF	INORGANIC	Boron	2	2		2		2	53.75	39.4	68.1	Ephemeral	5000	µg/L	Y
Twomile above Pajarito	2004	UF	INORGANIC	Cadmium	2	2		2		2	5.795	4.3	7.29	Ephemeral	2.1	µg/L	Y
Twomile above Pajarito	2004	UF	INORGANIC	Chemical Oxygen Demand	2	2		2		2	1370000	1170000	1570000	Ephemeral	120	µg/L	Y
Twomile above Pajarito	2004	UF	INORGANIC	Chromium	2	2		2		2	66.95	37.7	96.2	Ephemeral	580	µg/L	Y
Twomile above Pajarito	2004	UF	INORGANIC	Cobalt	2	2		2		2	47.35	41.1	53.6	Ephemeral	1000	µg/L	Y
Twomile above Pajarito	2004	UF	INORGANIC	Copper	2	2		2		2	102.75	78.5	127	Ephemeral	14	µg/L	Y
Twomile above Pajarito	2004	UF	INORGANIC	Cyanide [Total]	1	1		1		1	4.12	4.12	4.12	Ephemeral	0.0636	µg/L	Y
Twomile above Pajarito	2004	UF	INORGANIC	Cyanide, Amenable to Chlorination	1		1		1	1				Ephemeral	0.0052	µg/L	N
Twomile above Pajarito	2004	UF	INORGANIC	Lead	2	2		2		2	206.5	154	259	Ephemeral	81.7	µg/L	Y
Twomile above Pajarito	2004	UF	INORGANIC	Magnesium	2	2		2		2	23250	15500	31000	Ephemeral	0.0636	µg/L	Y
Twomile above Pajarito	2004	UF	INORGANIC	Mercury	1	1		1		1	0.38	0.38	0.38	Ephemeral	0.77	µg/L	Y
Twomile above Pajarito	2004	UF	INORGANIC	Nickel	2	2		2		2	70.45	51.2	89.7	Ephemeral	469	µg/L	Y
Twomile above Pajarito	2004	UF	INORGANIC	Selenium	2	1	1	1	1	2	6.23	6.23	6.23	Ephemeral	5	µg/L	Y
Twomile above Pajarito	2004	UF	INORGANIC	Silver	2		2		2	2				Ephemeral	3.8	µg/L	N
Twomile above Pajarito	2004	UF	INORGANIC	Thallium	2	2		2		2	1.37	0.77	1.97	Ephemeral	6.3	µg/L	Y
Twomile above Pajarito	2004	UF	INORGANIC	Vanadium	2	2		2		2	152.5	101	204	Ephemeral	100	µg/L	Y
Twomile above Pajarito	2004	UF	INORGANIC	Zinc	2	2		2		2	790.5	595	986	Ephemeral	120	µg/L	Y
Twomile above Pajarito	2004	UF	RAD	Gross alpha	2	2		2		2	657.5	235	1080	Ephemeral	15	pCi/L	Y
Twomile above Pajarito	2007	UF	INORGANIC	Aluminum	4	4		4		4	61300	12000	117000	Ephemeral	750	µg/L	Y
Twomile above Pajarito	2007	UF	INORGANIC	Antimony	4	1	3	1	3	4	1.9	1.9	1.9	Ephemeral	640	µg/L	Y

Location ID	Year	Field Prep	RFI Class	Analyte Name	Number of Analyses	Detected	Nondetect	Count Detect > Wsal	Count Nd > Wsal	Total Analyses > Wsal	Average	Min	Max	Stream Type	Wsal	Units	Ever Detected?
Twomile above Pajarito	2007	UF	INORGANIC	Arsenic	4	3	1	3	1	4	22.833333	15.4	33.7	Ephemeral	9	µg/L	Y
Twomile above Pajarito	2007	UF	INORGANIC	Cadmium	4	4		4		4	4.4825	0.13	9.6	Ephemeral	2.1	µg/L	Y
Twomile above Pajarito	2007	UF	INORGANIC	Chromium	4	4		4		4	59.15	5.8	101	Ephemeral	580	µg/L	Y
Twomile above Pajarito	2007	UF	INORGANIC	Cobalt	4	3	1	3	1	4	55.466667	25.7	88.5	Ephemeral	1000	µg/L	Y
Twomile above Pajarito	2007	UF	INORGANIC	Copper	4	4		4		4	93.65	7.1	182	Ephemeral	14	µg/L	Y
Twomile above Pajarito	2007	UF	INORGANIC	Cyanide [Total]	4	1	3	1	3	4	7.59	7.59	7.59	Ephemeral	0.0636	µg/L	Y
Twomile above Pajarito	2007	UF	INORGANIC	Cyanide, Amenable to Chlorination	3		3		3	3				Ephemeral	0.0052	µg/L	N
Twomile above Pajarito	2007	UF	INORGANIC	Lead	4	4		4		4	217.55	8.2	364	Ephemeral	81.7	µg/L	Y
Twomile above Pajarito	2007	UF	INORGANIC	Magnesium	4	4		4		4	17042.5	5170	30700	Ephemeral	0.0636	µg/L	Y
Twomile above Pajarito	2007	UF	INORGANIC	Mercury	4	3	1	3	1	4	0.2256667	0.077	0.41	Ephemeral	0.77	µg/L	Y
Twomile above Pajarito	2007	UF	INORGANIC	Nickel	4	4		4		4	56.125	6.3	95.7	Ephemeral	469	µg/L	Y
Twomile above Pajarito	2007	UF	INORGANIC	Selenium	4	2	2	2	2	4	3.4	2.6	4.2	Ephemeral	5	µg/L	Y
Twomile above Pajarito	2007	UF	INORGANIC	Silver	4	3	1	3	1	4	2.1533333	0.86	2.9	Ephemeral	3.8	µg/L	Y
Twomile above Pajarito	2007	UF	INORGANIC	Thallium	4	2	2	2	2	4	1.44	0.88	2	Ephemeral	6.3	µg/L	Y
Twomile above Pajarito	2007	UF	INORGANIC	Vanadium	4	4		4		4	107.825	10.4	208	Ephemeral	100	µg/L	Y
Twomile above Pajarito	2007	UF	INORGANIC	Zinc	4	4		4		4	674.125	32.5	1440	Ephemeral	120	µg/L	Y
Twomile above Pajarito	2007	UF	ORGANIC	Aroclor-1016	3		3		3	3				Ephemeral	0.00064	µg/L	N
Twomile above Pajarito	2007	UF	ORGANIC	Aroclor-1221	3		3		3	3				Ephemeral	0.00064	µg/L	N
Twomile above Pajarito	2007	UF	ORGANIC	Aroclor-1232	3		3		3	3				Ephemeral	0.00064	µg/L	N
Twomile above Pajarito	2007	UF	ORGANIC	Aroclor-1242	3		3		3	3				Ephemeral	0.00064	µg/L	N
Twomile above Pajarito	2007	UF	ORGANIC	Aroclor-1248	3		3		3	3				Ephemeral	0.00064	µg/L	N
Twomile above Pajarito	2007	UF	ORGANIC	Aroclor-1254	3	2	1	2	1	3	0.13	0.12	0.14	Ephemeral	0.00064	µg/L	Y
Twomile above Pajarito	2007	UF	ORGANIC	Aroclor-1260	3	2	1	2	1	3	0.099	0.068	0.13	Ephemeral	0.00064	µg/L	Y
Twomile above Pajarito	2007	UF	ORGANIC	Aroclor-1262	3		3		3	3				Ephemeral	0.00064	µg/L	N
Twomile above Pajarito	2007	UF	ORGANIC	RDX	2		2		2	2				Ephemeral	200	µg/L	N
Twomile above Pajarito	2007	UF	ORGANIC	Tetrachlorodibenzodioxin[2,3,7,8-]	3		3		3	3				Ephemeral	5.1E-08	µg/L	N
Twomile above Pajarito	2007	UF	ORGANIC	Trinitrotoluene[2,4,6-]	3		3		3	3				Ephemeral	20	µg/L	N
Twomile above Pajarito	2007	UF	RAD	Gross alpha	4	4		4		4	203.975	57.9	288	Ephemeral	15	pCi/L	Y
Twomile above Pajarito	2007	UF	RAD	Tritium	1		1		1	1				Ephemeral	20000	pCi/L	N

Location ID	Year	Field Prep	RFI Class	Analyte Name	Number of Analyses	Detected	Nondetect	Count Detect > Wsal	Count Nd > Wsal	Total Analyses > Wsal	Average	Min	Max	Stream Type	Wsal	Units	Ever Detected?
Pajarito above TA-18	2001	UF	INORGANIC	Aluminum	2	2		2		2	108900	55800	162000	Ephemeral	750	µg/L	Y
Pajarito above TA-18	2001	UF	INORGANIC	Antimony	1	1		1		1	1.65	1.65	1.65	Ephemeral	640	µg/L	Y
Pajarito above TA-18	2001	UF	INORGANIC	Arsenic	2	1	1	1	1	2	45	45	45	Ephemeral	9	µg/L	Y
Pajarito above TA-18	2001	UF	INORGANIC	Boron	2	1	1	1	1	2	27.1	27.1	27.1	Ephemeral	5000	µg/L	Y
Pajarito above TA-18	2001	UF	INORGANIC	Cadmium	2	2		2		2	4.06	1.74	6.38	Ephemeral	2.1	µg/L	Y
Pajarito above TA-18	2001	UF	INORGANIC	Chromium	2	2		2		2	59.05	28.2	89.9	Ephemeral	580	µg/L	Y
Pajarito above TA-18	2001	UF	INORGANIC	Cobalt	2	2		2		2	32.8	13.8	51.8	Ephemeral	1000	µg/L	Y
Pajarito above TA-18	2001	UF	INORGANIC	Copper	2	2		2		2	102.85	50.7	155	Ephemeral	14	µg/L	Y
Pajarito above TA-18	2001	UF	INORGANIC	Lead	2	2		2		2	185.25	84.5	286	Ephemeral	81.7	µg/L	Y
Pajarito above TA-18	2001	UF	INORGANIC	Magnesium	2	2		2		2	19800	10400	29200	Ephemeral	0.0636	µg/L	Y
Pajarito above TA-18	2001	UF	INORGANIC	Mercury	2		2		2	2				Ephemeral	0.77	µg/L	N
Pajarito above TA-18	2001	UF	INORGANIC	Nickel	2	2		2		2	60.45	26.9	94	Ephemeral	469	µg/L	Y
Pajarito above TA-18	2001	UF	INORGANIC	Selenium	2	1	1	1	1	2	8.89	8.89	8.89	Ephemeral	5	µg/L	Y
Pajarito above TA-18	2001	UF	INORGANIC	Silver	2	1	1	1	1	2	1.81	1.81	1.81	Ephemeral	3.8	µg/L	Y
Pajarito above TA-18	2001	UF	INORGANIC	Thallium	2	1	1	1	1	2	2.1	2.1	2.1	Ephemeral	6.3	µg/L	Y
Pajarito above TA-18	2001	UF	INORGANIC	Vanadium	2	2		2		2	115.6	56.2	175	Ephemeral	100	µg/L	Y
Pajarito above TA-18	2001	UF	INORGANIC	Zinc	2	2		2		2	559.5	306	813	Ephemeral	120	µg/L	Y
Pajarito above TA-18	2001	UF	RAD	Gross alpha	1	1		1		1	170	170	170	Ephemeral	15	pCi/L	Y
Pajarito above TA-18	2001	UF	RAD	Radium-226	1	1		1		1	2.33	2.33	2.33	Ephemeral	30	pCi/L	Y
Pajarito above TA-18	2001	UF	RAD	Radium-228	1	1		1		1	2.38	2.38	2.38	Ephemeral	30	pCi/L	Y
Pajarito above TA-18	2001	UF	RAD	Tritium	1		1		1	1				Ephemeral	20000	pCi/L	N
Pajarito above TA-18	2005	UF	INORGANIC	Aluminum	4	4		4		4	87975	40600	174000	Ephemeral	750	µg/L	Y
Pajarito above TA-18	2005	UF	INORGANIC	Antimony	4	1	3	1	3	4	1.6	1.6	1.6	Ephemeral	640	µg/L	Y
Pajarito above TA-18	2005	UF	INORGANIC	Arsenic	4	4		4		4	17.125	9.4	33.5	Ephemeral	9	µg/L	Y
Pajarito above TA-18	2005	UF	INORGANIC	Cadmium	4	4		4		4	2.775	1.2	5.9	Ephemeral	2.1	µg/L	Y
Pajarito above TA-18	2005	UF	INORGANIC	Chromium	4	4		4		4	56.675	25	116	Ephemeral	580	µg/L	Y
Pajarito above TA-18	2005	UF	INORGANIC	Cobalt	4	4		4		4	22.55	9.1	48.1	Ephemeral	1000	µg/L	Y
Pajarito above TA-18	2005	UF	INORGANIC	Copper	4	4		4		4	73.975	36.7	155	Ephemeral	14	µg/L	Y
Pajarito above TA-18	2005	UF	INORGANIC	Lead	4	4		4		4	103.3	34.6	209	Ephemeral	81.7	µg/L	Y

Location ID	Year	Field Prep	RFI Class	Analyte Name	Number of Analyses	Detected	Nondetect	Count Detect > Wsal	Count Nd > Wsal	Total Analyses > Wsal	Average	Min	Max	Stream Type	Wsal	Units	Ever Detected?
Pajarito above TA-18	2005	UF	INORGANIC	Magnesium	4	4		4		4	14130	7350	27600	Ephemeral	0.0636	µg/L	Y
Pajarito above TA-18	2005	UF	INORGANIC	Mercury	4	3	1	3	1	4	0.29	0.06	0.5	Ephemeral	0.77	µg/L	Y
Pajarito above TA-18	2005	UF	INORGANIC	Nickel	4	4		4		4	51.125	20.5	117	Ephemeral	469	µg/L	Y
Pajarito above TA-18	2005	UF	INORGANIC	Selenium	4		4		4	4				Ephemeral	5	µg/L	N
Pajarito above TA-18	2005	UF	INORGANIC	Silver	4	4		4		4	6.6	2.6	11.7	Ephemeral	3.8	µg/L	Y
Pajarito above TA-18	2005	UF	INORGANIC	Thallium	4	4		4		4	1.31	0.49	2.7	Ephemeral	6.3	µg/L	Y
Pajarito above TA-18	2005	UF	INORGANIC	Vanadium	4	4		4		4	101.975	41.4	211	Ephemeral	100	µg/L	Y
Pajarito above TA-18	2005	UF	INORGANIC	Zinc	4	4		4		4	311.75	142	593	Ephemeral	120	µg/L	Y
Pajarito above TA-18	2005	UF	ORGANIC	Aroclor-1016	3		3		3	3				Ephemeral	0.00064	µg/L	N
Pajarito above TA-18	2005	UF	ORGANIC	Aroclor-1221	3		3		3	3				Ephemeral	0.00064	µg/L	N
Pajarito above TA-18	2005	UF	ORGANIC	Aroclor-1232	3		3		3	3				Ephemeral	0.00064	µg/L	N
Pajarito above TA-18	2005	UF	ORGANIC	Aroclor-1242	3		3		3	3				Ephemeral	0.00064	µg/L	N
Pajarito above TA-18	2005	UF	ORGANIC	Aroclor-1248	3		3		3	3				Ephemeral	0.00064	µg/L	N
Pajarito above TA-18	2005	UF	ORGANIC	Aroclor-1254	3		3		3	3				Ephemeral	0.00064	µg/L	N
Pajarito above TA-18	2005	UF	ORGANIC	Aroclor-1260	3		3		3	3				Ephemeral	0.00064	µg/L	N
Pajarito above TA-18	2005	UF	ORGANIC	RDX	3		3		3	3				Ephemeral	200	µg/L	N
Pajarito above TA-18	2005	UF	ORGANIC	Trinitrotoluene[2,4,6-]	3		3		3	3				Ephemeral	20	µg/L	N
Pajarito above TA-18	2005	UF	RAD	Gross alpha	3	3		3		3	43.966667	22.5	77.3	Ephemeral	15	pCi/L	Y
Pajarito above TA-18	2005	UF	RAD	Tritium	4	1	3	1	3	4	198	198	198	Ephemeral	20000	pCi/L	Y
Pajarito above TA-18	2006	UF	INORGANIC	Aluminum	3	3		3		3	16736.667	4610	23300	Ephemeral	750	µg/L	Y
Pajarito above TA-18	2006	UF	INORGANIC	Arsenic	3	2	1	2	1	3	10.1	6.3	13.9	Ephemeral	9	µg/L	Y
Pajarito above TA-18	2006	UF	INORGANIC	Cadmium	3	3		3		3	1.5766667	0.19	3.6	Ephemeral	2.1	µg/L	Y
Pajarito above TA-18	2006	UF	INORGANIC	Chromium	3	3		3		3	7.1	3.4	9.7	Ephemeral	580	µg/L	Y
Pajarito above TA-18	2006	UF	INORGANIC	Copper	3	3		3		3	18.7	5.7	31.9	Ephemeral	14	µg/L	Y
Pajarito above TA-18	2006	UF	INORGANIC	Cyanide [Total]	3	1	2	1	2	3	2.12	2.12	2.12	Ephemeral	0.0636	µg/L	Y
Pajarito above TA-18	2006	UF	INORGANIC	Cyanide, Amenable to Chlorination	3		3		3	3				Ephemeral	0.0052	µg/L	N
Pajarito above TA-18	2006	UF	INORGANIC	Lead	3	3		3		3	50.966667	3.5	126	Ephemeral	81.7	µg/L	Y
Pajarito above TA-18	2006	UF	INORGANIC	Magnesium	3	3		3		3	7073.3333	4640	9980	Ephemeral	0.0636	µg/L	Y
Pajarito above TA-18	2006	UF	INORGANIC	Selenium	3		3		3	3				Ephemeral	5	µg/L	N

Location ID	Year	Field Prep	RFI Class	Analyte Name	Number of Analyses	Detected	Nondetect	Count Detect > Wsal	Count Nd > Wsal	Total Analyses > Wsal	Average	Min	Max	Stream Type	Wsal	Units	Ever Detected?
Pajarito above TA-18	2006	UF	INORGANIC	Silver	3	2	1	2	1	3	0.695	0.57	0.82	Ephemeral	3.8	µg/L	Y
Pajarito above TA-18	2006	UF	INORGANIC	Thallium	3		3		3	3				Ephemeral	6.3	µg/L	N
Pajarito above TA-18	2006	UF	INORGANIC	Vanadium	3	3		3		3	37.833333	5.6	85.2	Ephemeral	100	µg/L	Y
Pajarito above TA-18	2006	UF	INORGANIC	Zinc	3	3		3		3	215.46667	28.3	534	Ephemeral	120	µg/L	Y
Pajarito above TA-18	2006	UF	ORGANIC	Aroclor-1016	1		1		1	1				Ephemeral	0.00064	µg/L	N
Pajarito above TA-18	2006	UF	ORGANIC	Aroclor-1221	1		1		1	1				Ephemeral	0.00064	µg/L	N
Pajarito above TA-18	2006	UF	ORGANIC	Aroclor-1232	1		1		1	1				Ephemeral	0.00064	µg/L	N
Pajarito above TA-18	2006	UF	ORGANIC	Aroclor-1242	1		1		1	1				Ephemeral	0.00064	µg/L	N
Pajarito above TA-18	2006	UF	ORGANIC	Aroclor-1248	1		1		1	1				Ephemeral	0.00064	µg/L	N
Pajarito above TA-18	2006	UF	ORGANIC	Aroclor-1254	1		1		1	1				Ephemeral	0.00064	µg/L	N
Pajarito above TA-18	2006	UF	ORGANIC	Aroclor-1260	1		1		1	1				Ephemeral	0.00064	µg/L	N
Pajarito above TA-18	2006	UF	ORGANIC	Aroclor-1262	1		1		1	1				Ephemeral	0.00064	µg/L	N
Pajarito above TA-18	2006	UF	ORGANIC	RDX	1	1		1		1	0.332	0.332	0.332	Ephemeral	200	µg/L	Y
Pajarito above TA-18	2006	UF	ORGANIC	Trinitrotoluene[2,4,6-]	1		1		1	1				Ephemeral	20	µg/L	N
Pajarito above TA-18	2006	UF	RAD	Gross alpha	3	3		3		3	97.61	3.23	242	Ephemeral	15	pCi/L	Y
Pajarito above TA-18	2006	UF	RAD	Radium-226	3	2	1	2	1	3	21.195	1.79	40.6	Ephemeral	30	pCi/L	Y
Pajarito above TA-18	2004	UF	INORGANIC	Aluminum	2	2		2		2	73450	60700	86200	Ephemeral	750	µg/L	Y
Pajarito above TA-18	2004	UF	INORGANIC	Antimony	2		2		2	2				Ephemeral	640	µg/L	N
Pajarito above TA-18	2004	UF	INORGANIC	Arsenic	2	1	1	1	1	2	17.4	17.4	17.4	Ephemeral	9	µg/L	Y
Pajarito above TA-18	2004	UF	INORGANIC	Boron	2	2		2		2	35.4	32	38.8	Ephemeral	5000	µg/L	Y
Pajarito above TA-18	2004	UF	INORGANIC	Cadmium	2	2		2		2	1.8	1.5	2.1	Ephemeral	2.1	µg/L	Y
Pajarito above TA-18	2004	UF	INORGANIC	Chromium	2	2		2		2	41.4	33.1	49.7	Ephemeral	580	µg/L	Y
Pajarito above TA-18	2004	UF	INORGANIC	Cobalt	2	2		2		2	15.7	13.4	18	Ephemeral	1000	µg/L	Y
Pajarito above TA-18	2004	UF	INORGANIC	Copper	2	2		2		2	47	39.2	54.8	Ephemeral	14	µg/L	Y
Pajarito above TA-18	2004	UF	INORGANIC	Lead	2	2		2		2	82.1	60.2	104	Ephemeral	81.7	µg/L	Y
Pajarito above TA-18	2004	UF	INORGANIC	Magnesium	2	2		2		2	13050	11600	14500	Ephemeral	0.0636	µg/L	Y
Pajarito above TA-18	2004	UF	INORGANIC	Mercury	2	2		2		2	0.135	0.13	0.14	Ephemeral	0.77	µg/L	Y
Pajarito above TA-18	2004	UF	INORGANIC	Nickel	2	2		2		2	34.15	28.2	40.1	Ephemeral	469	µg/L	Y
Pajarito above TA-18	2004	UF	INORGANIC	Selenium	2	1	1	1	1	2	2.3	2.3	2.3	Ephemeral	5	µg/L	Y

Location ID	Year	Field Prep	RFI Class	Analyte Name	Number of Analyses	Detected	Nondetect	Count Detect > Wsal	Count Nd > Wsal	Total Analyses > Wsal	Average	Min	Max	Stream Type	Wsal	Units	Ever Detected?
Pajarito above TA-18	2004	UF	INORGANIC	Silver	2	1	1	1	1	2	1.2	1.2	1.2	Ephemeral	3.8	µg/L	Y
Pajarito above TA-18	2004	UF	INORGANIC	Thallium	2	2		2		2	0.955	0.81	1.1	Ephemeral	6.3	µg/L	Y
Pajarito above TA-18	2004	UF	INORGANIC	Vanadium	2	2		2		2	80.35	64.2	96.5	Ephemeral	100	µg/L	Y
Pajarito above TA-18	2004	UF	INORGANIC	Zinc	2	2		2		2	306	244	368	Ephemeral	120	µg/L	Y
Pajarito above TA-18	2004	UF	ORGANIC	Aroclor-1016	2		2		2	2				Ephemeral	0.00064	µg/L	N
Pajarito above TA-18	2004	UF	ORGANIC	Aroclor-1221	2		2		2	2				Ephemeral	0.00064	µg/L	N
Pajarito above TA-18	2004	UF	ORGANIC	Aroclor-1232	2		2		2	2				Ephemeral	0.00064	µg/L	N
Pajarito above TA-18	2004	UF	ORGANIC	Aroclor-1242	2		2		2	2				Ephemeral	0.00064	µg/L	N
Pajarito above TA-18	2004	UF	ORGANIC	Aroclor-1248	2		2		2	2				Ephemeral	0.00064	µg/L	N
Pajarito above TA-18	2004	UF	ORGANIC	Aroclor-1254	2		2		2	2				Ephemeral	0.00064	µg/L	N
Pajarito above TA-18	2004	UF	ORGANIC	Aroclor-1260	2		2		2	2				Ephemeral	0.00064	µg/L	N
Pajarito above TA-18	2004	UF	RAD	Gross alpha	1	1		1		1	29.7	29.7	29.7	Ephemeral	15	pCi/L	Y
Pajarito above TA-18	2004	UF	RAD	Tritium	2		2		2	2				Ephemeral	20000	pCi/L	N
Pajarito above TA-18	2007	UF	INORGANIC	Aluminum	4	4		4		4	66297.5	1790	111000	Ephemeral	750	µg/L	Y
Pajarito above TA-18	2007	UF	INORGANIC	Antimony	4	1	3	1	3	4	0.53	0.53	0.53	Ephemeral	640	µg/L	Y
Pajarito above TA-18	2007	UF	INORGANIC	Arsenic	4	3	1	3	1	4	18.766667	14.6	23.6	Ephemeral	9	µg/L	Y
Pajarito above TA-18	2007	UF	INORGANIC	Cadmium	4	4		4		4	3.875	1.2	6.8	Ephemeral	2.1	µg/L	Y
Pajarito above TA-18	2007	UF	INORGANIC	Chromium	4	4		4		4	37.175	14.2	69.1	Ephemeral	580	µg/L	Y
Pajarito above TA-18	2007	UF	INORGANIC	Cobalt	4	4		4		4	27.4	3.8	43.1	Ephemeral	1000	µg/L	Y
Pajarito above TA-18	2007	UF	INORGANIC	Copper	4	4		4		4	93.8	15.5	198	Ephemeral	14	µg/L	Y
Pajarito above TA-18	2007	UF	INORGANIC	Cyanide [Total]	4	1	3	1	3	4	2.51	2.51	2.51	Ephemeral	0.0636	µg/L	Y
Pajarito above TA-18	2007	UF	INORGANIC	Cyanide, Amenable to Chlorination	3		3		3	3				Ephemeral	0.0052	µg/L	N
Pajarito above TA-18	2007	UF	INORGANIC	Lead	4	4		4		4	114.2	34.7	176	Ephemeral	81.7	µg/L	Y
Pajarito above TA-18	2007	UF	INORGANIC	Magnesium	4	4		4		4	14202.5	4910	19300	Ephemeral	0.0636	µg/L	Y
Pajarito above TA-18	2007	UF	INORGANIC	Mercury	4	1	3	1	3	4	0.14	0.14	0.14	Ephemeral	0.77	µg/L	Y
Pajarito above TA-18	2007	UF	INORGANIC	Nickel	4	4		4		4	51.65	13.6	107	Ephemeral	469	µg/L	Y
Pajarito above TA-18	2007	UF	INORGANIC	Selenium	4	1	3	1	3	4	1.4	1.4	1.4	Ephemeral	5	µg/L	Y
Pajarito above TA-18	2007	UF	INORGANIC	Silver	4	4		4		4	18.515	0.96	64.7	Ephemeral	3.8	µg/L	Y
Pajarito above TA-18	2007	UF	INORGANIC	Thallium	4	2	2	2	2	4	1.35	0.7	2	Ephemeral	6.3	µg/L	Y

Location ID	Year	Field Prep	RFI Class	Analyte Name	Number of Analyses	Detected	Nondetect	Count Detect > Wsal	Count Nd > Wsal	Total Analyses > Wsal	Average	Min	Max	Stream Type	Wsal	Units	Ever Detected?
Pajarito above TA-18	2007	UF	INORGANIC	Vanadium	4	4		4		4	93.625	7.3	153	Ephemeral	100	µg/L	Y
Pajarito above TA-18	2007	UF	INORGANIC	Zinc	4	4		4		4	363.425	55.7	556	Ephemeral	120	µg/L	Y
Pajarito above TA-18	2007	UF	ORGANIC	RDX	4		4		4	4				Ephemeral	200	µg/L	N
Pajarito above TA-18	2007	UF	ORGANIC	Trinitrotoluene[2,4,6-]	4		4		4	4				Ephemeral	20	µg/L	N
Pajarito above TA-18	2007	UF	RAD	Gross alpha	4	4		4		4	132.3	33.8	206	Ephemeral	15	pCi/L	Y
Pajarito above TA-18	2007	UF	RAD	Tritium	1		1		1	1				Ephemeral	20000	pCi/L	N
Pajarito above TA-18	2008	UF	INORGANIC	Aluminum	1	1		1		1	4640	4640	4640	Ephemeral	750	µg/L	Y
Pajarito above TA-18	2008	UF	INORGANIC	Antimony	1		1		1	1				Ephemeral	640	µg/L	N
Pajarito above TA-18	2008	UF	INORGANIC	Arsenic	1		1		1	1				Ephemeral	9	µg/L	N
Pajarito above TA-18	2008	UF	INORGANIC	Cadmium	1		1		1	1				Ephemeral	2.1	µg/L	N
Pajarito above TA-18	2008	UF	INORGANIC	Chromium	1		1		1	1				Ephemeral	580	µg/L	N
Pajarito above TA-18	2008	UF	INORGANIC	Cobalt	1		1		1	1				Ephemeral	1000	µg/L	N
Pajarito above TA-18	2008	UF	INORGANIC	Copper	1		1		1	1				Ephemeral	14	µg/L	N
Pajarito above TA-18	2008	UF	INORGANIC	Cyanide [Total]	1		1		1	1				Ephemeral	0.0636	µg/L	N
Pajarito above TA-18	2008	UF	INORGANIC	Cyanide, Amenable to Chlorination	1		1		1	1				Ephemeral	0.0052	µg/L	N
Pajarito above TA-18	2008	UF	INORGANIC	Lead	1	1		1		1	1.6	1.6	1.6	Ephemeral	81.7	µg/L	Y
Pajarito above TA-18	2008	UF	INORGANIC	Magnesium	1	1		1		1	4250	4250	4250	Ephemeral	0.0636	µg/L	Y
Pajarito above TA-18	2008	UF	INORGANIC	Nickel	1	1		1		1	2.3	2.3	2.3	Ephemeral	469	µg/L	Y
Pajarito above TA-18	2008	UF	INORGANIC	Selenium	1		1		1	1				Ephemeral	5	µg/L	N
Pajarito above TA-18	2008	UF	INORGANIC	Silver	1	1		1		1	0.39	0.39	0.39	Ephemeral	3.8	µg/L	Y
Pajarito above TA-18	2008	UF	INORGANIC	Thallium	1		1		1	1				Ephemeral	6.3	µg/L	N
Pajarito above TA-18	2008	UF	INORGANIC	Vanadium	1	1		1		1	5	5	5	Ephemeral	100	µg/L	Y
Pajarito above TA-18	2008	UF	INORGANIC	Zinc	1	1		1		1	15.3	15.3	15.3	Ephemeral	120	µg/L	Y
Pajarito above TA-18	2008	UF	RAD	Gross alpha	1	1		1		1	2.43	2.43	2.43	Ephemeral	15	pCi/L	Y
Pajarito above TA-18	2008	UF	RAD	Radium-226	1		1		1	1				Ephemeral	30	pCi/L	N
Pajarito above Threemile	2002	UF	INORGANIC	Aluminum	2	2		2		2	100000	86000	114000	Ephemeral	750	µg/L	Y
Pajarito above Threemile	2002	UF	INORGANIC	Ammonia as Nitrogen	1	1		1		1	184	184	184	Ephemeral	39.1	µg/L	Y
Pajarito above Threemile	2002	UF	INORGANIC	Antimony	2	1	1	1	1	2	0.967	0.967	0.967	Ephemeral	640	µg/L	Y
Pajarito above Threemile	2002	UF	INORGANIC	Arsenic	2	2		2		2	22	16.3	27.7	Ephemeral	9	µg/L	Y

Location ID	Year	Field Prep	RFI Class	Analyte Name	Number of Analyses	Detected	Nondetect	Count Detect > Wsal	Count Nd > Wsal	Total Analyses > Wsal	Average	Min	Max	Stream Type	Wsal	Units	Ever Detected?
Pajarito above Threemile	2002	UF	INORGANIC	Boron	2	2		2		2	32.35	11.8	52.9	Ephemeral	5000	µg/L	Y
Pajarito above Threemile	2002	UF	INORGANIC	Cadmium	2	2		2		2	6.015	1.53	10.5	Ephemeral	2.1	µg/L	Y
Pajarito above Threemile	2002	UF	INORGANIC	Chemical Oxygen Demand	2	1	1	1	1	2	408000	408000	408000	Ephemeral	120	µg/L	Y
Pajarito above Threemile	2002	UF	INORGANIC	Chromium	2	2		2		2	43.35	42.9	43.8	Ephemeral	580	µg/L	Y
Pajarito above Threemile	2002	UF	INORGANIC	Cobalt	2	2		2		2	88.45	15.9	161	Ephemeral	1000	µg/L	Y
Pajarito above Threemile	2002	UF	INORGANIC	Copper	2	2		2		2	68.9	61	76.8	Ephemeral	14	µg/L	Y
Pajarito above Threemile	2002	UF	INORGANIC	Cyanide [Total]	2	1	1	1	1	2	16.9	16.9	16.9	Ephemeral	0.0636	µg/L	Y
Pajarito above Threemile	2002	UF	INORGANIC	Cyanide, Amenable to Chlorination	2		2		2	2				Ephemeral	0.0052	µg/L	N
Pajarito above Threemile	2002	UF	INORGANIC	Lead	2	2		2		2	84.9	77.2	92.6	Ephemeral	81.7	µg/L	Y
Pajarito above Threemile	2002	UF	INORGANIC	Mercury	2		2		2	2				Ephemeral	0.77	µg/L	N
Pajarito above Threemile	2002	UF	INORGANIC	Nickel	2	2		2		2	80.65	35.3	126	Ephemeral	469	µg/L	Y
Pajarito above Threemile	2002	UF	INORGANIC	Nitrate-Nitrite as Nitrogen	2	1	1	1	1	2	250	250	250	Ephemeral	132	µg/L	Y
Pajarito above Threemile	2002	UF	INORGANIC	Selenium	2		2		2	2				Ephemeral	5	µg/L	N
Pajarito above Threemile	2002	UF	INORGANIC	Silver	2	2		2		2	1.689	0.878	2.5	Ephemeral	3.8	µg/L	Y
Pajarito above Threemile	2002	UF	INORGANIC	Thallium	2	2		2		2	1.1255	0.911	1.34	Ephemeral	6.3	µg/L	Y
Pajarito above Threemile	2002	UF	INORGANIC	Vanadium	2	2		2		2	112.85	80.7	145	Ephemeral	100	µg/L	Y
Pajarito above Threemile	2002	UF	INORGANIC	Zinc	2	2		2		2	632.5	309	956	Ephemeral	120	µg/L	Y
Pajarito above Threemile	2002	UF	RAD	Gross alpha	1	1		1		1	964	964	964	Ephemeral	15	pCi/L	Y
Pajarito above Threemile	2002	UF	RAD	Radium-226	1		1		1	1				Ephemeral	30	pCi/L	N
Pajarito above Threemile	2002	UF	RAD	Radium-228	1		1		1	1				Ephemeral	30	pCi/L	N
Pajarito above Threemile	2002	UF	RAD	Tritium	2		2		2	2				Ephemeral	20000	pCi/L	N
Pajarito above Threemile	1999	UF	INORGANIC	Aluminum	2	2		2		2	29400	6900	51900	Ephemeral	750	µg/L	Y
Pajarito above Threemile	1999	UF	INORGANIC	Ammonia	1	1		1		1	500	500	500	Ephemeral	39.1	µg/L	Y
Pajarito above Threemile	1999	UF	INORGANIC	Antimony	1		1		1	1				Ephemeral	640	µg/L	N
Pajarito above Threemile	1999	UF	INORGANIC	Arsenic	2	1	1	1	1	2	4	4	4	Ephemeral	9	µg/L	Y
Pajarito above Threemile	1999	UF	INORGANIC	Boron	1	1		1		1	37	37	37	Ephemeral	5000	µg/L	Y
Pajarito above Threemile	1999	UF	INORGANIC	Cadmium	2	1	1	1	1	2	7	7	7	Ephemeral	2.1	µg/L	Y
Pajarito above Threemile	1999	UF	INORGANIC	Chemical Oxygen Demand	1	1		1		1	231000	231000	231000	Ephemeral	120	µg/L	Y
Pajarito above Threemile	1999	UF	INORGANIC	Chromium	1		1		1	1				Ephemeral	580	µg/L	N

Location ID	Year	Field Prep	RFI Class	Analyte Name	Number of Analyses	Detected	Nondetect	Count Detect > Wsal	Count Nd > Wsal	Total Analyses > Wsal	Average	Min	Max	Stream Type	Wsal	Units	Ever Detected?
Pajarito above Threemile	1999	UF	INORGANIC	Cobalt	1	1		1		1	15	15	15	Ephemeral	1000	µg/L	Y
Pajarito above Threemile	1999	UF	INORGANIC	Copper	2	2		2		2	82	64	100	Ephemeral	14	µg/L	Y
Pajarito above Threemile	1999	UF	INORGANIC	Cyanide [Total]	1		1		1	1				Ephemeral	0.0636	µg/L	N
Pajarito above Threemile	1999	UF	INORGANIC	Lead	2	1	1	1	1	2	120	120	120	Ephemeral	81.7	µg/L	Y
Pajarito above Threemile	1999	UF	INORGANIC	Magnesium	1	1		1		1	15900	15900	15900	Ephemeral	0.0636	µg/L	Y
Pajarito above Threemile	1999	UF	INORGANIC	Mercury	2	2		2		2	0.87	0.24	1.5	Ephemeral	0.77	µg/L	Y
Pajarito above Threemile	1999	UF	INORGANIC	Nickel	1	1		1		1	36	36	36	Ephemeral	469	µg/L	Y
Pajarito above Threemile	1999	UF	INORGANIC	Selenium	2	1	1	1	1	2	50	50	50	Ephemeral	5	µg/L	Y
Pajarito above Threemile	1999	UF	INORGANIC	Silver	2	1	1	1	1	2	17	17	17	Ephemeral	3.8	µg/L	Y
Pajarito above Threemile	1999	UF	INORGANIC	Thallium	1		1		1	1				Ephemeral	6.3	µg/L	N
Pajarito above Threemile	1999	UF	INORGANIC	Vanadium	1	1		1		1	29	29	29	Ephemeral	100	µg/L	Y
Pajarito above Threemile	1999	UF	INORGANIC	Zinc	2	2		2		2	335	160	510	Ephemeral	120	µg/L	Y
Pajarito above Threemile	1999	UF	ORGANIC	Aroclor-1016	1		1		1	1				Ephemeral	0.00064	µg/L	N
Pajarito above Threemile	1999	UF	ORGANIC	Aroclor-1221	1		1		1	1				Ephemeral	0.00064	µg/L	N
Pajarito above Threemile	1999	UF	ORGANIC	Aroclor-1232	1		1		1	1				Ephemeral	0.00064	µg/L	N
Pajarito above Threemile	1999	UF	ORGANIC	Aroclor-1242	1		1		1	1				Ephemeral	0.00064	µg/L	N
Pajarito above Threemile	1999	UF	ORGANIC	Aroclor-1248	1		1		1	1				Ephemeral	0.00064	µg/L	N
Pajarito above Threemile	1999	UF	ORGANIC	Aroclor-1254	1		1		1	1				Ephemeral	0.00064	µg/L	N
Pajarito above Threemile	1999	UF	ORGANIC	Aroclor-1260	1		1		1	1				Ephemeral	0.00064	µg/L	N
Pajarito above Threemile	1999	UF	ORGANIC	Benzo[a]pyrene	1		1		1	1				Ephemeral	0.18	µg/L	N
Pajarito above Threemile	1999	UF	ORGANIC	Hexachlorobenzene	1		1		1	1				Ephemeral	0.0029	µg/L	N
Pajarito above Threemile	1999	UF	ORGANIC	Pentachlorophenol	1		1		1	1				Ephemeral	19	µg/L	N
Pajarito above Threemile	1999	UF	RAD	Gross alpha	1	1		1		1	52.1	52.1	52.1	Ephemeral	15	pCi/L	Y
Pajarito above Threemile	2003	F	INORGANIC	Chemical Oxygen Demand	1	1		1		1	39900	39900	39900	Ephemeral	120	µg/L	Y
Pajarito above Threemile	2003	F	INORGANIC	Nitrate-Nitrite as Nitrogen	1	1		1		1	420	420	420	Ephemeral	132	µg/L	Y
Pajarito above Threemile	2003	UF	INORGANIC	Aluminum	1	1		1		1	4580	4580	4580	Ephemeral	750	µg/L	Y
Pajarito above Threemile	2003	UF	INORGANIC	Antimony	1		1		1	1				Ephemeral	640	µg/L	N
Pajarito above Threemile	2003	UF	INORGANIC	Arsenic	1	1		1		1	2.32	2.32	2.32	Ephemeral	9	µg/L	Y
Pajarito above Threemile	2003	UF	INORGANIC	Boron	1	1		1		1	26.1	26.1	26.1	Ephemeral	5000	µg/L	Y

Location ID	Year	Field Prep	RFI Class	Analyte Name	Number of Analyses	Detected	Nondetect	Count Detect > Wsal	Count Nd > Wsal	Total Analyses > Wsal	Average	Min	Max	Stream Type	Wsal	Units	Ever Detected?
Pajarito above Threemile	2003	UF	INORGANIC	Cadmium	1	1		1		1	3.92	3.92	3.92	Ephemeral	2.1	µg/L	Y
Pajarito above Threemile	2003	UF	INORGANIC	Chromium	1	1		1		1	1.84	1.84	1.84	Ephemeral	580	µg/L	Y
Pajarito above Threemile	2003	UF	INORGANIC	Cobalt	1	1		1		1	16.6	16.6	16.6	Ephemeral	1000	µg/L	Y
Pajarito above Threemile	2003	UF	INORGANIC	Copper	1	1		1		1	9.06	9.06	9.06	Ephemeral	14	µg/L	Y
Pajarito above Threemile	2003	UF	INORGANIC	Cyanide [Total]	1		1		1	1				Ephemeral	0.0636	µg/L	N
Pajarito above Threemile	2003	UF	INORGANIC	Lead	1	1		1		1	14.7	14.7	14.7	Ephemeral	81.7	µg/L	Y
Pajarito above Threemile	2003	UF	INORGANIC	Nickel	1	1		1		1	24.2	24.2	24.2	Ephemeral	469	µg/L	Y
Pajarito above Threemile	2003	UF	INORGANIC	Selenium	1		1		1	1				Ephemeral	5	µg/L	N
Pajarito above Threemile	2003	UF	INORGANIC	Silver	1		1		1	1				Ephemeral	3.8	µg/L	N
Pajarito above Threemile	2003	UF	INORGANIC	Thallium	1	1		1		1	0.069	0.069	0.069	Ephemeral	6.3	µg/L	Y
Pajarito above Threemile	2003	UF	INORGANIC	Vanadium	1	1		1		1	13.9	13.9	13.9	Ephemeral	100	µg/L	Y
Pajarito above Threemile	2003	UF	INORGANIC	Zinc	1	1		1		1	354	354	354	Ephemeral	120	µg/L	Y
Pajarito above Threemile	2003	UF	RAD	Gross alpha	1	1		1		1	311	311	311	Ephemeral	15	pCi/L	Y
Pajarito above Threemile	2003	UF	RAD	Radium-226	1	1		1		1	11.1	11.1	11.1	Ephemeral	30	pCi/L	Y
Pajarito above Threemile	2003	UF	RAD	Radium-228	1	1		1		1	13.1	13.1	13.1	Ephemeral	30	pCi/L	Y
Pajarito above Threemile	2005	UF	INORGANIC	Aluminum	4	4		4		4	98725	33400	155000	Ephemeral	750	µg/L	Y
Pajarito above Threemile	2005	UF	INORGANIC	Antimony	4	2	2	2	2	4	1.1	0.6	1.6	Ephemeral	640	µg/L	Y
Pajarito above Threemile	2005	UF	INORGANIC	Arsenic	4	4		4		4	21.2	9	30.7	Ephemeral	9	µg/L	Y
Pajarito above Threemile	2005	UF	INORGANIC	Cadmium	4	3	1	3	1	4	3.4666667	2.2	5.2	Ephemeral	2.1	µg/L	Y
Pajarito above Threemile	2005	UF	INORGANIC	Chromium	4	4		4		4	63.025	21.8	91.8	Ephemeral	580	µg/L	Y
Pajarito above Threemile	2005	UF	INORGANIC	Cobalt	4	3	1	3	1	4	34.133333	26	41	Ephemeral	1000	µg/L	Y
Pajarito above Threemile	2005	UF	INORGANIC	Copper	4	4		4		4	74.075	33	113	Ephemeral	14	µg/L	Y
Pajarito above Threemile	2005	UF	INORGANIC	Lead	4	4		4		4	132.9	46.6	202	Ephemeral	81.7	µg/L	Y
Pajarito above Threemile	2005	UF	INORGANIC	Magnesium	4	4		4		4	17355	8420	25300	Ephemeral	0.0636	µg/L	Y
Pajarito above Threemile	2005	UF	INORGANIC	Mercury	4	3	1	3	1	4	0.1236667	0.051	0.21	Ephemeral	0.77	µg/L	Y
Pajarito above Threemile	2005	UF	INORGANIC	Nickel	4	4		4		4	48.425	21.2	61.5	Ephemeral	469	µg/L	Y
Pajarito above Threemile	2005	UF	INORGANIC	Selenium	4		4		4	4				Ephemeral	5	µg/L	N
Pajarito above Threemile	2005	UF	INORGANIC	Silver	4	4		4		4	2.85	2.3	3.7	Ephemeral	3.8	µg/L	Y
Pajarito above Threemile	2005	UF	INORGANIC	Thallium	4	4		4		4	1.3475	0.49	2.3	Ephemeral	6.3	µg/L	Y

Location ID	Year	Field Prep	RFI Class	Analyte Name	Number of Analyses	Detected	Nondetect	Count Detect > Wsal	Count Nd > Wsal	Total Analyses > Wsal	Average	Min	Max	Stream Type	Wsal	Units	Ever Detected?
Pajarito above Threemile	2005	UF	INORGANIC	Vanadium	4	4		4		4	114.25	40	161	Ephemeral	100	µg/L	Y
Pajarito above Threemile	2005	UF	INORGANIC	Zinc	4	4		4		4	443.25	135	782	Ephemeral	120	µg/L	Y
Pajarito above Threemile	2005	UF	ORGANIC	Aroclor-1016	4		4		4	4				Ephemeral	0.00064	µg/L	N
Pajarito above Threemile	2005	UF	ORGANIC	Aroclor-1221	4		4		4	4				Ephemeral	0.00064	µg/L	N
Pajarito above Threemile	2005	UF	ORGANIC	Aroclor-1232	4		4		4	4				Ephemeral	0.00064	µg/L	N
Pajarito above Threemile	2005	UF	ORGANIC	Aroclor-1242	4		4		4	4				Ephemeral	0.00064	µg/L	N
Pajarito above Threemile	2005	UF	ORGANIC	Aroclor-1248	4		4		4	4				Ephemeral	0.00064	µg/L	N
Pajarito above Threemile	2005	UF	ORGANIC	Aroclor-1254	4		4		4	4				Ephemeral	0.00064	µg/L	N
Pajarito above Threemile	2005	UF	ORGANIC	Aroclor-1260	4		4		4	4				Ephemeral	0.00064	µg/L	N
Pajarito above Threemile	2005	UF	ORGANIC	RDX	4		4		4	4				Ephemeral	200	µg/L	N
Pajarito above Threemile	2005	UF	ORGANIC	Trinitrotoluene[2,4,6-]	4		4		4	4				Ephemeral	20	µg/L	N
Pajarito above Threemile	2005	UF	RAD	Gross alpha	4	4		4		4	89.7	34.2	218	Ephemeral	15	pCi/L	Y
Pajarito above Threemile	2005	UF	RAD	Tritium	4		4		4	4				Ephemeral	20000	pCi/L	N
Pajarito above Threemile	2006	UF	INORGANIC	Aluminum	3	3		3		3	129900	67700	208000	Ephemeral	750	µg/L	Y
Pajarito above Threemile	2006	UF	INORGANIC	Arsenic	3	3		3		3	30.466667	9.7	47.2	Ephemeral	9	µg/L	Y
Pajarito above Threemile	2006	UF	INORGANIC	Cadmium	3	3		3		3	5.6	2.5	11.4	Ephemeral	2.1	µg/L	Y
Pajarito above Threemile	2006	UF	INORGANIC	Chromium	3	3		3		3	61.833333	28	107	Ephemeral	580	µg/L	Y
Pajarito above Threemile	2006	UF	INORGANIC	Copper	3	3		3		3	129.83333	40.5	242	Ephemeral	14	µg/L	Y
Pajarito above Threemile	2006	UF	INORGANIC	Cyanide [Total]	2	1	1	1	1	2	3.61	3.61	3.61	Ephemeral	0.0636	µg/L	Y
Pajarito above Threemile	2006	UF	INORGANIC	Cyanide, Amenable to Chlorination	1		1		1	1				Ephemeral	0.0052	µg/L	N
Pajarito above Threemile	2006	UF	INORGANIC	Lead	3	3		3		3	166.66667	134	189	Ephemeral	81.7	µg/L	Y
Pajarito above Threemile	2006	UF	INORGANIC	Magnesium	3	3		3		3	23296.667	9590	38500	Ephemeral	0.0636	µg/L	Y
Pajarito above Threemile	2006	UF	INORGANIC	Selenium	3		3		3	3				Ephemeral	5	µg/L	N
Pajarito above Threemile	2006	UF	INORGANIC	Silver	3	3		3		3	7.9866667	0.76	20.7	Ephemeral	3.8	µg/L	Y
Pajarito above Threemile	2006	UF	INORGANIC	Thallium	3	2	1	2	1	3	2.1	1.6	2.6	Ephemeral	6.3	µg/L	Y
Pajarito above Threemile	2006	UF	INORGANIC	Vanadium	3	3		3		3	165.33333	67	278	Ephemeral	100	µg/L	Y
Pajarito above Threemile	2006	UF	INORGANIC	Zinc	3	3		3		3	684.66667	199	1150	Ephemeral	120	µg/L	Y
Pajarito above Threemile	2006	UF	RAD	Gross alpha	3	3		3		3	557	127	1300	Ephemeral	15	pCi/L	Y
Pajarito above Threemile	2006	UF	RAD	Radium-226	3	3		3		3	9.08	3.75	17.3	Ephemeral	30	pCi/L	Y

Location ID	Year	Field Prep	RFI Class	Analyte Name	Number of Analyses	Detected	Nondetect	Count Detect > Wsal	Count Nd > Wsal	Total Analyses > Wsal	Average	Min	Max	Stream Type	Wsal	Units	Ever Detected?
Pajarito above Threemile	2004	UF	INORGANIC	Aluminum	3	3		3		3	113166.67	11500	173000	Ephemeral	750	µg/L	Y
Pajarito above Threemile	2004	UF	INORGANIC	Antimony	3	1	2	1	2	3	0.22	0.22	0.22	Ephemeral	640	µg/L	Y
Pajarito above Threemile	2004	UF	INORGANIC	Arsenic	3	2	1	2	1	3	42.8	42.5	43.1	Ephemeral	9	µg/L	Y
Pajarito above Threemile	2004	UF	INORGANIC	Boron	3	3		3		3	47.733333	22.7	62.1	Ephemeral	5000	µg/L	Y
Pajarito above Threemile	2004	UF	INORGANIC	Cadmium	3	3		3		3	3.7	2.2	4.7	Ephemeral	2.1	µg/L	Y
Pajarito above Threemile	2004	UF	INORGANIC	Chromium	3	3		3		3	60.433333	3.1	89.1	Ephemeral	580	µg/L	Y
Pajarito above Threemile	2004	UF	INORGANIC	Cobalt	3	3		3		3	38.733333	29.5	44.9	Ephemeral	1000	µg/L	Y
Pajarito above Threemile	2004	UF	INORGANIC	Copper	3	3		3		3	91.566667	33.7	121	Ephemeral	14	µg/L	Y
Pajarito above Threemile	2004	UF	INORGANIC	Lead	3	3		3		3	173.4	81.2	230	Ephemeral	81.7	µg/L	Y
Pajarito above Threemile	2004	UF	INORGANIC	Magnesium	3	3		3		3	20383.333	7850	27600	Ephemeral	0.0636	µg/L	Y
Pajarito above Threemile	2004	UF	INORGANIC	Mercury	2	2		2		2	0.185	0.12	0.25	Ephemeral	0.77	µg/L	Y
Pajarito above Threemile	2004	UF	INORGANIC	Nickel	3	3		3		3	65.133333	29.9	82.8	Ephemeral	469	µg/L	Y
Pajarito above Threemile	2004	UF	INORGANIC	Selenium	3		3		3	3				Ephemeral	5	µg/L	N
Pajarito above Threemile	2004	UF	INORGANIC	Silver	3		3		3	3				Ephemeral	3.8	µg/L	N
Pajarito above Threemile	2004	UF	INORGANIC	Thallium	3	2	1	2	1	3	1.9	1.4	2.4	Ephemeral	6.3	µg/L	Y
Pajarito above Threemile	2004	UF	INORGANIC	Vanadium	3	3		3		3	138	50	189	Ephemeral	100	µg/L	Y
Pajarito above Threemile	2004	UF	INORGANIC	Zinc	3	3		3		3	544	173	808	Ephemeral	120	µg/L	Y
Pajarito above Threemile	2004	UF	ORGANIC	Aroclor-1016	1		1		1	1				Ephemeral	0.00064	µg/L	N
Pajarito above Threemile	2004	UF	ORGANIC	Aroclor-1221	1		1		1	1				Ephemeral	0.00064	µg/L	N
Pajarito above Threemile	2004	UF	ORGANIC	Aroclor-1232	1		1		1	1				Ephemeral	0.00064	µg/L	N
Pajarito above Threemile	2004	UF	ORGANIC	Aroclor-1242	1		1		1	1				Ephemeral	0.00064	µg/L	N
Pajarito above Threemile	2004	UF	ORGANIC	Aroclor-1248	1		1		1	1				Ephemeral	0.00064	µg/L	N
Pajarito above Threemile	2004	UF	ORGANIC	Aroclor-1254	1		1		1	1				Ephemeral	0.00064	µg/L	N
Pajarito above Threemile	2004	UF	ORGANIC	Aroclor-1260	1		1		1	1				Ephemeral	0.00064	ug/L	N
Pajarito above Threemile	2004	UF	RAD	Gross alpha	2	2		2		2	227.5	221	234	Ephemeral	15	pCi/L	Y
Pajarito above Threemile	2004	UF	RAD	Tritium	1		1		1	1				Ephemeral	20000	pCi/L	N
Pajarito above Threemile	2007	UF	INORGANIC	Aluminum	4	4		4		4	69382.5	6730	107000	Ephemeral	750	µg/L	Y
Pajarito above Threemile	2007	UF	INORGANIC	Antimony	4	2	2	2	2	4	1.735	0.77	2.7	Ephemeral	640	µg/L	Y
Pajarito above Threemile	2007	UF	INORGANIC	Arsenic	4	3	1	3	1	4	16.966667	5.7	27.8	Ephemeral	9	µg/L	Y

Location ID	Year	Field Prep	RFI Class	Analyte Name	Number of Analyses	Detected	Nondetect	Count Detect > Wsal	Count Nd > Wsal	Total Analyses > Wsal	Average	Min	Max	Stream Type	Wsal	Units	Ever Detected?
Pajarito above Threemile	2007	UF	INORGANIC	Cadmium	4	4		4		4	4.375	2.6	8.8	Ephemeral	2.1	µg/L	Y
Pajarito above Threemile	2007	UF	INORGANIC	Chromium	4	4		4		4	64.775	28.1	108	Ephemeral	580	µg/L	Y
Pajarito above Threemile	2007	UF	INORGANIC	Cobalt	4	4		4		4	29.7	17.3	44.4	Ephemeral	1000	µg/L	Y
Pajarito above Threemile	2007	UF	INORGANIC	Copper	4	4		4		4	126.35	38.4	277	Ephemeral	14	µg/L	Y
Pajarito above Threemile	2007	UF	INORGANIC	Cyanide [Total]	4		4		4	4				Ephemeral	0.0636	µg/L	N
Pajarito above Threemile	2007	UF	INORGANIC	Cyanide, Amenable to Chlorination	4		4		4	4				Ephemeral	0.0052	µg/L	N
Pajarito above Threemile	2007	UF	INORGANIC	Lead	4	4		4		4	155.875	97.5	211	Ephemeral	81.7	µg/L	Y
Pajarito above Threemile	2007	UF	INORGANIC	Magnesium	4	4		4		4	14267.5	6870	20500	Ephemeral	0.0636	µg/L	Y
Pajarito above Threemile	2007	UF	INORGANIC	Mercury	4	3	1	3	1	4	0.1296667	0.099	0.16	Ephemeral	0.77	µg/L	Y
Pajarito above Threemile	2007	UF	INORGANIC	Nickel	4	4		4		4	82.05	34.4	160	Ephemeral	469	µg/L	Y
Pajarito above Threemile	2007	UF	INORGANIC	Selenium	4		4		4	4				Ephemeral	5	µg/L	N
Pajarito above Threemile	2007	UF	INORGANIC	Silver	4	4		4		4	19.7	2.7	41.9	Ephemeral	3.8	µg/L	Y
Pajarito above Threemile	2007	UF	INORGANIC	Thallium	4	2	2	2	2	4	1.75	1.6	1.9	Ephemeral	6.3	µg/L	Y
Pajarito above Threemile	2007	UF	INORGANIC	Vanadium	4	4		4		4	95.525	30.8	138	Ephemeral	100	µg/L	Y
Pajarito above Threemile	2007	UF	INORGANIC	Zinc	4	4		4		4	358.25	178	577	Ephemeral	120	µg/L	Y
Pajarito above Threemile	2007	UF	ORGANIC	Aroclor-1016	3		3		3	3				Ephemeral	0.00064	µg/L	N
Pajarito above Threemile	2007	UF	ORGANIC	Aroclor-1221	3		3		3	3				Ephemeral	0.00064	µg/L	N
Pajarito above Threemile	2007	UF	ORGANIC	Aroclor-1232	3		3		3	3				Ephemeral	0.00064	µg/L	N
Pajarito above Threemile	2007	UF	ORGANIC	Aroclor-1242	3		3		3	3				Ephemeral	0.00064	µg/L	N
Pajarito above Threemile	2007	UF	ORGANIC	Aroclor-1248	3		3		3	3				Ephemeral	0.00064	µg/L	N
Pajarito above Threemile	2007	UF	ORGANIC	Aroclor-1254	3	1	2	1	2	3	0.076	0.076	0.076	Ephemeral	0.00064	µg/L	Y
Pajarito above Threemile	2007	UF	ORGANIC	Aroclor-1260	3	1	2	1	2	3	0.06	0.06	0.06	Ephemeral	0.00064	µg/L	Y
Pajarito above Threemile	2007	UF	ORGANIC	Aroclor-1262	3		3		3	3				Ephemeral	0.00064	µg/L	N
Pajarito above Threemile	2007	UF	ORGANIC	RDX	3		3		3	3				Ephemeral	200	µg/L	N
Pajarito above Threemile	2007	UF	ORGANIC	Trinitrotoluene[2,4,6-]	3		3		3	3				Ephemeral	20	µg/L	N
Pajarito above Threemile	2007	UF	RAD	Gross alpha	3	3		3		3	210	190	249	Ephemeral	15	pCi/L	Y
Pajarito above Threemile	2007	UF	RAD	Radium-226	1	1		1		1	18.9	18.9	18.9	Ephemeral	30	pCi/L	Y
Pajarito above Threemile	2008	UF	INORGANIC	Aluminum	1	1		1		1	5180	5180	5180	Ephemeral	750	µg/L	Y
Pajarito above Threemile	2008	UF	INORGANIC	Antimony	1		1		1	1				Ephemeral	640	µg/L	N

Location ID	Year	Field Prep	RFI Class	Analyte Name	Number of Analyses	Detected	Nondetect	Count Detect > Wsal	Count Nd > Wsal	Total Analyses > Wsal	Average	Min	Max	Stream Type	Wsal	Units	Ever Detected?
Pajarito above Threemile	2008	UF	INORGANIC	Arsenic	1		1		1	1				Ephemeral	9	µg/L	N
Pajarito above Threemile	2008	UF	INORGANIC	Cadmium	1	1		1		1	0.14	0.14	0.14	Ephemeral	2.1	µg/L	Y
Pajarito above Threemile	2008	UF	INORGANIC	Chromium	1	1		1		1	2.8	2.8	2.8	Ephemeral	580	µg/L	Y
Pajarito above Threemile	2008	UF	INORGANIC	Cobalt	1		1		1	1				Ephemeral	1000	µg/L	N
Pajarito above Threemile	2008	UF	INORGANIC	Copper	1		1		1	1				Ephemeral	14	µg/L	N
Pajarito above Threemile	2008	UF	INORGANIC	Cyanide [Total]	1		1		1	1				Ephemeral	0.0636	µg/L	N
Pajarito above Threemile	2008	UF	INORGANIC	Cyanide, Amenable to Chlorination	1		1		1	1				Ephemeral	0.0052	µg/L	N
Pajarito above Threemile	2008	UF	INORGANIC	Lead	1	1		1		1	2.2	2.2	2.2	Ephemeral	81.7	µg/L	Y
Pajarito above Threemile	2008	UF	INORGANIC	Magnesium	1	1		1		1	3690	3690	3690	Ephemeral	0.0636	µg/L	Y
Pajarito above Threemile	2008	UF	INORGANIC	Nickel	1	1		1		1	2.9	2.9	2.9	Ephemeral	469	µg/L	Y
Pajarito above Threemile	2008	UF	INORGANIC	Selenium	1		1		1	1				Ephemeral	5	µg/L	N
Pajarito above Threemile	2008	UF	INORGANIC	Silver	1	1		1		1	0.47	0.47	0.47	Ephemeral	3.8	µg/L	Y
Pajarito above Threemile	2008	UF	INORGANIC	Thallium	1		1		1	1				Ephemeral	6.3	µg/L	N
Pajarito above Threemile	2008	UF	INORGANIC	Vanadium	1	1		1		1	5.4	5.4	5.4	Ephemeral	100	µg/L	Y
Pajarito above Threemile	2008	UF	INORGANIC	Zinc	1	1		1		1	14.9	14.9	14.9	Ephemeral	120	µg/L	Y
Pajarito above Threemile	2008	UF	RAD	Gross alpha	1	1		1		1	2.62	2.62	2.62	Ephemeral	15	pCi/L	Y
Pajarito above Threemile	2008	UF	RAD	Radium-226	1		1		1	1				Ephemeral	30	pCi/L	N
Threemile above Pajarito	2003	UF	INORGANIC	Ammonia as Nitrogen	1	1		1		1	1480	1480	1480	Ephemeral	39.1	µg/L	Y
Threemile above Pajarito	2003	UF	INORGANIC	Arsenic	1	1		1		1	14.4	14.4	14.4	Ephemeral	9	µg/L	Y
Threemile above Pajarito	2003	UF	INORGANIC	Cadmium	1	1		1		1	5.9	5.9	5.9	Ephemeral	2.1	µg/L	Y
Threemile above Pajarito	2003	UF	INORGANIC	Chemical Oxygen Demand	1	1		1		1	80400	80400	80400	Ephemeral	120	µg/L	Y
Threemile above Pajarito	2003	UF	INORGANIC	Cyanide [Total]	1	1		1		1	9.87	9.87	9.87	Ephemeral	0.0636	µg/L	Y
Threemile above Pajarito	2003	UF	INORGANIC	Lead	1	1		1		1	124	124	124	Ephemeral	81.7	µg/L	Y
Threemile above Pajarito	2003	UF	INORGANIC	Magnesium	1	1		1		1	15100	15100	15100	Ephemeral	0.0636	µg/L	Y
Threemile above Pajarito	2003	UF	INORGANIC	Mercury	1		1		1	1				Ephemeral	0.77	µg/L	N
Threemile above Pajarito	2003	UF	INORGANIC	Selenium	1	1		1		1	1.07	1.07	1.07	Ephemeral	5	µg/L	Y
Threemile above Pajarito	2003	UF	INORGANIC	Silver	1	1		1		1	0.424	0.424	0.424	Ephemeral	3.8	µg/L	Y
Threemile above Pajarito	2006	UF	INORGANIC	Aluminum	1	1		1		1	69600	69600	69600	Ephemeral	750	µg/L	Y
Threemile above Pajarito	2006	UF	INORGANIC	Ammonia as Nitrogen	1	1		1		1	740	740	740	Ephemeral	39.1	µg/L	Y

Location ID	Year	Field Prep	RFI Class	Analyte Name	Number of Analyses	Detected	Nondetect	Count Detect > Wsal	Count Nd > Wsal	Total Analyses > Wsal	Average	Min	Max	Stream Type	Wsal	Units	Ever Detected?
Threemile above Pajarito	2006	UF	INORGANIC	Antimony	1		1		1	1				Ephemeral	640	µg/L	N
Threemile above Pajarito	2006	UF	INORGANIC	Arsenic	1	1		1		1	19.7	19.7	19.7	Ephemeral	9	µg/L	Y
Threemile above Pajarito	2006	UF	INORGANIC	Cadmium	1	1		1		1	7.3	7.3	7.3	Ephemeral	2.1	µg/L	Y
Threemile above Pajarito	2006	UF	INORGANIC	Chemical Oxygen Demand	1	1		1		1	2400000	2400000	2400000	Ephemeral	120	µg/L	Y
Threemile above Pajarito	2006	UF	INORGANIC	Chromium	1	1		1		1	24.7	24.7	24.7	Ephemeral	580	µg/L	Y
Threemile above Pajarito	2006	UF	INORGANIC	Cobalt	1	1		1		1	62.1	62.1	62.1	Ephemeral	1000	µg/L	Y
Threemile above Pajarito	2006	UF	INORGANIC	Copper	1	1		1		1	138	138	138	Ephemeral	14	µg/L	Y
Threemile above Pajarito	2006	UF	INORGANIC	Cyanide [Total]	1	1		1		1	5.4	5.4	5.4	Ephemeral	0.0636	µg/L	Y
Threemile above Pajarito	2006	UF	INORGANIC	Cyanide, Amenable to Chlorination	1		1		1	1				Ephemeral	0.0052	µg/L	N
Threemile above Pajarito	2006	UF	INORGANIC	Lead	1	1		1		1	151	151	151	Ephemeral	81.7	µg/L	Y
Threemile above Pajarito	2006	UF	INORGANIC	Magnesium	1	1		1		1	17300	17300	17300	Ephemeral	0.0636	µg/L	Y
Threemile above Pajarito	2006	UF	INORGANIC	Mercury	1		1		1	1				Ephemeral	0.77	µg/L	N
Threemile above Pajarito	2006	UF	INORGANIC	Nickel	1	1		1		1	56.6	56.6	56.6	Ephemeral	469	µg/L	Y
Threemile above Pajarito	2006	UF	INORGANIC	Selenium	1		1		1	1				Ephemeral	5	µg/L	N
Threemile above Pajarito	2006	UF	INORGANIC	Silver	1	1		1		1	0.36	0.36	0.36	Ephemeral	3.8	µg/L	Y
Threemile above Pajarito	2006	UF	INORGANIC	Thallium	1		1		1	1				Ephemeral	6.3	µg/L	N
Threemile above Pajarito	2006	UF	INORGANIC	Vanadium	1	1		1		1	114	114	114	Ephemeral	100	µg/L	Y
Threemile above Pajarito	2006	UF	INORGANIC	Zinc	1	1		1		1	565	565	565	Ephemeral	120	µg/L	Y
Threemile above Pajarito	2006	UF	ORGANIC	Aroclor-1016	1		1		1	1				Ephemeral	0.00064	µg/L	N
Threemile above Pajarito	2006	UF	ORGANIC	Aroclor-1221	1		1		1	1				Ephemeral	0.00064	µg/L	N
Threemile above Pajarito	2006	UF	ORGANIC	Aroclor-1232	1		1		1	1				Ephemeral	0.00064	µg/L	N
Threemile above Pajarito	2006	UF	ORGANIC	Aroclor-1242	1		1		1	1				Ephemeral	0.00064	µg/L	N
Threemile above Pajarito	2006	UF	ORGANIC	Aroclor-1248	1		1		1	1				Ephemeral	0.00064	µg/L	N
Threemile above Pajarito	2006	UF	ORGANIC	Aroclor-1254	1		1		1	1				Ephemeral	0.00064	µg/L	N
Threemile above Pajarito	2006	UF	ORGANIC	Aroclor-1260	1		1		1	1				Ephemeral	0.00064	µg/L	N
Threemile above Pajarito	2006	UF	ORGANIC	Aroclor-1262	1		1		1	1				Ephemeral	0.00064	µg/L	N
Threemile above Pajarito	2006	UF	ORGANIC	RDX	1		1		1	1				Ephemeral	200	µg/L	N
Threemile above Pajarito	2006	UF	ORGANIC	Trinitrotoluene[2,4,6-]	1		1		1	1				Ephemeral	20	µg/L	N
Threemile above Pajarito	2006	UF	RAD	Gross alpha	1	1		1		1	240	240	240	Ephemeral	15	pCi/L	Y

Location ID	Year	Field Prep	RFI Class	Analyte Name	Number of Analyses	Detected	Nondetect	Count Detect > Wsal	Count Nd > Wsal	Total Analyses > Wsal	Average	Min	Max	Stream Type	Wsal	Units	Ever Detected?
Threemile above Pajarito	2006	UF	RAD	Radium-226	1	1		1		1	15.1	15.1	15.1	Ephemeral	30	pCi/L	Y
Threemile above Pajarito	2006	UF	RAD	Tritium	1		1		1	1				Ephemeral	20000	pCi/L	N
Threemile above Pajarito	2004	UF	INORGANIC	Aluminum	2	2		2		2	67150	8300	126000	Ephemeral	750	µg/L	Y
Threemile above Pajarito	2004	UF	INORGANIC	Ammonia as Nitrogen	2	2		2		2	658	327	989	Ephemeral	39.1	µg/L	Y
Threemile above Pajarito	2004	UF	INORGANIC	Antimony	2		2		2	2				Ephemeral	640	µg/L	N
Threemile above Pajarito	2004	UF	INORGANIC	Arsenic	2	1	1	1	1	2	30.5	30.5	30.5	Ephemeral	9	µg/L	Y
Threemile above Pajarito	2004	UF	INORGANIC	Boron	2	2		2		2	43.85	22.5	65.2	Ephemeral	5000	µg/L	Y
Threemile above Pajarito	2004	UF	INORGANIC	Cadmium	2	2		2		2	4	1.6	6.4	Ephemeral	2.1	µg/L	Y
Threemile above Pajarito	2004	UF	INORGANIC	Chemical Oxygen Demand	2	2		2		2	369950	45900	694000	Ephemeral	120	µg/L	Y
Threemile above Pajarito	2004	UF	INORGANIC	Chromium	2	2		2		2	32.95	3.3	62.6	Ephemeral	580	µg/L	Y
Threemile above Pajarito	2004	UF	INORGANIC	Cobalt	2	2		2		2	33.65	15.4	51.9	Ephemeral	1000	µg/L	Y
Threemile above Pajarito	2004	UF	INORGANIC	Copper	2	2		2		2	117	64	170	Ephemeral	14	µg/L	Y
Threemile above Pajarito	2004	UF	INORGANIC	Cyanide [Total]	1	1		1		1	2.24	2.24	2.24	Ephemeral	0.0636	µg/L	Y
Threemile above Pajarito	2004	UF	INORGANIC	Cyanide, Amenable to Chlorination	1		1		1	1				Ephemeral	0.0052	µg/L	N
Threemile above Pajarito	2004	UF	INORGANIC	Lead	2	2		2		2	164.3	88.6	240	Ephemeral	81.7	µg/L	Y
Threemile above Pajarito	2004	UF	INORGANIC	Magnesium	2	2		2		2	13845	4490	23200	Ephemeral	0.0636	µg/L	Y
Threemile above Pajarito	2004	UF	INORGANIC	Mercury	1	1		1		1	0.12	0.12	0.12	Ephemeral	0.77	µg/L	Y
Threemile above Pajarito	2004	UF	INORGANIC	Nickel	2	2		2		2	43.3	12.1	74.5	Ephemeral	469	µg/L	Y
Threemile above Pajarito	2004	UF	INORGANIC	Selenium	2		2		2	2				Ephemeral	5	µg/L	N
Threemile above Pajarito	2004	UF	INORGANIC	Silver	2		2		2	2				Ephemeral	3.8	µg/L	N
Threemile above Pajarito	2004	UF	INORGANIC	Thallium	2	1	1	1	1	2	1.1	1.1	1.1	Ephemeral	6.3	µg/L	Y
Threemile above Pajarito	2004	UF	INORGANIC	Vanadium	2	2		2		2	100.45	23.9	177	Ephemeral	100	µg/L	Y
Threemile above Pajarito	2004	UF	INORGANIC	Zinc	2	2		2		2	306.95	79.9	534	Ephemeral	120	µg/L	Y
Threemile above Pajarito	2004	UF	ORGANIC	Aroclor-1016	1		1		1	1				Ephemeral	0.00064	µg/L	N
Threemile above Pajarito	2004	UF	ORGANIC	Aroclor-1221	1		1		1	1				Ephemeral	0.00064	µg/L	N
Threemile above Pajarito	2004	UF	ORGANIC	Aroclor-1232	1		1		1	1				Ephemeral	0.00064	µg/L	N
Threemile above Pajarito	2004	UF	ORGANIC	Aroclor-1242	1		1		1	1				Ephemeral	0.00064	µg/L	N
Threemile above Pajarito	2004	UF	ORGANIC	Aroclor-1248	1		1		1	1				Ephemeral	0.00064	µg/L	N
Threemile above Pajarito	2004	UF	ORGANIC	Aroclor-1254	1		1		1	1				Ephemeral	0.00064	µg/L	N

Location ID	Year	Field Prep	RFI Class	Analyte Name	Number of Analyses	Detected	Nondetect	Count Detect > Wsal	Count Nd > Wsal	Total Analyses > Wsal	Average	Min	Max	Stream Type	Wsal	Units	Ever Detected?
Threemile above Pajarito	2004	UF	ORGANIC	Aroclor-1260	1		1		1	1				Ephemeral	0.00064	µg/L	N
Threemile above Pajarito	2004	UF	ORGANIC	RDX	1		1		1	1				Ephemeral	200	µg/L	N
Threemile above Pajarito	2004	UF	ORGANIC	Trinitrotoluene[2,4,6-]	1		1		1	1				Ephemeral	20	µg/L	N
Threemile above Pajarito	2004	UF	RAD	Gross alpha	2	2		2		2	206	148	264	Ephemeral	15	pCi/L	Y
Threemile above Pajarito	2004	UF	RAD	Tritium	1	1		1		1	160	160	160	Ephemeral	20000	pCi/L	Y
Threemile above Pajarito	2007	UF	INORGANIC	Aluminum	3	3		3		3	4359	347	7190	Ephemeral	750	µg/L	Y
Threemile above Pajarito	2007	UF	INORGANIC	Antimony	3		3		3	3				Ephemeral	640	µg/L	N
Threemile above Pajarito	2007	UF	INORGANIC	Arsenic	3		3		3	3				Ephemeral	9	µg/L	N
Threemile above Pajarito	2007	UF	INORGANIC	Cadmium	3	2	1	2	1	3	0.3	0.19	0.41	Ephemeral	2.1	µg/L	Y
Threemile above Pajarito	2007	UF	INORGANIC	Chromium	3	2	1	2	1	3	2.9	2.9	2.9	Ephemeral	580	µg/L	Y
Threemile above Pajarito	2007	UF	INORGANIC	Cobalt	3	2	1	2	1	3	10.75	1.2	20.3	Ephemeral	1000	µg/L	Y
Threemile above Pajarito	2007	UF	INORGANIC	Copper	2	2		2		2	8.75	5.9	11.6	Ephemeral	14	µg/L	Y
Threemile above Pajarito	2007	UF	INORGANIC	Cyanide [Total]	2	1	1	1	1	2	3	3	3	Ephemeral	0.0636	µg/L	Y
Threemile above Pajarito	2007	UF	INORGANIC	Cyanide, Amenable to Chlorination	2		2		2	2				Ephemeral	0.0052	µg/L	N
Threemile above Pajarito	2007	UF	INORGANIC	Lead	3	2	1	2	1	3	7.45	5.7	9.2	Ephemeral	81.7	µg/L	Y
Threemile above Pajarito	2007	UF	INORGANIC	Magnesium	3	3		3		3	4770	4460	5160	Ephemeral	0.0636	µg/L	Y
Threemile above Pajarito	2007	UF	INORGANIC	Mercury	3		3		3	3				Ephemeral	0.77	µg/L	N
Threemile above Pajarito	2007	UF	INORGANIC	Nickel	3	3		3		3	7.1666667	1.3	17.1	Ephemeral	469	µg/L	Y
Threemile above Pajarito	2007	UF	INORGANIC	Selenium	3		3		3	3				Ephemeral	5	µg/L	N
Threemile above Pajarito	2007	UF	INORGANIC	Silver	3		3		3	3				Ephemeral	3.8	µg/L	N
Threemile above Pajarito	2007	UF	INORGANIC	Thallium	3		3		3	3				Ephemeral	6.3	µg/L	N
Threemile above Pajarito	2007	UF	INORGANIC	Vanadium	3	3		3		3	5.8	1.1	10.5	Ephemeral	100	µg/L	Y
Threemile above Pajarito	2007	UF	INORGANIC	Zinc	3	2	1	2	1	3	62	51.4	72.6	Ephemeral	120	µg/L	Y
Threemile above Pajarito	2007	UF	ORGANIC	Aroclor-1016	2		2		2	2				Ephemeral	0.00064	µg/L	N
Threemile above Pajarito	2007	UF	ORGANIC	Aroclor-1221	2		2		2	2				Ephemeral	0.00064	µg/L	N
Threemile above Pajarito	2007	UF	ORGANIC	Aroclor-1232	2		2		2	2				Ephemeral	0.00064	µg/L	N
Threemile above Pajarito	2007	UF	ORGANIC	Aroclor-1242	2		2		2	2				Ephemeral	0.00064	µg/L	N
Threemile above Pajarito	2007	UF	ORGANIC	Aroclor-1248	2		2		2	2				Ephemeral	0.00064	µg/L	N
Threemile above Pajarito	2007	UF	ORGANIC	Aroclor-1254	2		2		2	2				Ephemeral	0.00064	µg/L	N

Location ID	Year	Field Prep	RFI Class	Analyte Name	Number of Analyses	Detected	Nondetect	Count Detect > Wsal	Count Nd > Wsal	Total Analyses > Wsal	Average	Min	Max	Stream Type	Wsal	Units	Ever Detected?
Threemile above Pajarito	2007	UF	ORGANIC	Aroclor-1260	2		2		2	2				Ephemeral	0.00064	µg/L	N
Threemile above Pajarito	2007	UF	ORGANIC	Aroclor-1262	2		2		2	2				Ephemeral	0.00064	µg/L	N
Threemile above Pajarito	2007	UF	ORGANIC	RDX	1		1		1	1				Ephemeral	200	µg/L	N
Threemile above Pajarito	2007	UF	ORGANIC	Trinitrotoluene[2,4,6-]	2		2		2	2				Ephemeral	20	µg/L	N
Threemile above Pajarito	2007	UF	RAD	Gross alpha	2	2		2		2	18.605	3.01	34.2	Ephemeral	15	pCi/L	Y
Threemile above Pajarito	2007	UF	RAD	Radium-226	1	1		1		1	0.337	0.337	0.337	Ephemeral	30	pCi/L	Y
Threemile above Pajarito	2007	UF	RAD	Tritium	1		1		1	1				Ephemeral	20000	pCi/L	N
Threemile above Pajarito	2008	UF	INORGANIC	Aluminum	1	1		1		1	3080	3080	3080	Ephemeral	750	µg/L	Y
Threemile above Pajarito	2008	UF	INORGANIC	Antimony	1		1		1	1				Ephemeral	640	µg/L	N
Threemile above Pajarito	2008	UF	INORGANIC	Arsenic	1		1		1	1				Ephemeral	9	µg/L	N
Threemile above Pajarito	2008	UF	INORGANIC	Cadmium	1		1		1	1				Ephemeral	2.1	µg/L	N
Threemile above Pajarito	2008	UF	INORGANIC	Chromium	1		1		1	1				Ephemeral	580	µg/L	N
Threemile above Pajarito	2008	UF	INORGANIC	Cobalt	1		1		1	1				Ephemeral	1000	µg/L	N
Threemile above Pajarito	2008	UF	INORGANIC	Copper	1		1		1	1				Ephemeral	14	µg/L	N
Threemile above Pajarito	2008	UF	INORGANIC	Cyanide [Total]	1	1		1		1	4.32	4.32	4.32	Ephemeral	0.0636	µg/L	Y
Threemile above Pajarito	2008	UF	INORGANIC	Cyanide, Amenable to Chlorination	1	1		1		1	3.1	3.1	3.1	Ephemeral	0.0052	µg/L	Y
Threemile above Pajarito	2008	UF	INORGANIC	Lead	1	1		1		1	1	1	1	Ephemeral	81.7	µg/L	Y
Threemile above Pajarito	2008	UF	INORGANIC	Magnesium	1	1		1		1	3930	3930	3930	Ephemeral	0.0636	µg/L	Y
Threemile above Pajarito	2008	UF	INORGANIC	Mercury	1		1		1	1				Ephemeral	0.77	µg/L	N
Threemile above Pajarito	2008	UF	INORGANIC	Nickel	1	1		1		1	1.4	1.4	1.4	Ephemeral	469	µg/L	Y
Threemile above Pajarito	2008	UF	INORGANIC	Selenium	1		1		1	1				Ephemeral	5	µg/L	N
Threemile above Pajarito	2008	UF	INORGANIC	Silver	1		1		1	1				Ephemeral	3.8	µg/L	N
Threemile above Pajarito	2008	UF	INORGANIC	Thallium	1		1		1	1				Ephemeral	6.3	µg/L	N
Threemile above Pajarito	2008	UF	INORGANIC	Vanadium	1	1		1		1	3.1	3.1	3.1	Ephemeral	100	µg/L	Y
Threemile above Pajarito	2008	UF	INORGANIC	Zinc	1	1		1		1	7.7	7.7	7.7	Ephemeral	120	µg/L	Y
Threemile above Pajarito	2008	UF	RAD	Gross alpha	1	1		1		1	1.64	1.64	1.64	Ephemeral	15	pCi/L	Y
Threemile above Pajarito	2008	UF	RAD	Radium-226	1		1		1	1				Ephemeral	30	pCi/L	N
Threemile above Pajarito	2008	UF	RAD	Tritium	1		1		1	1				Ephemeral	20000	pCi/L	N
Pajarito above SR-4	2000	UF	INORGANIC	Aluminum	3	3		3		3	57022.947	43300	80068.8	Ephemeral	750	µg/L	Y

Location ID	Year	Field Prep	RFI Class	Analyte Name	Number of Analyses	Detected	Nondetect	Count Detect > Wsal	Count Nd > Wsal	Total Analyses > Wsal	Average	Min	Max	Stream Type	Wsal	Units	Ever Detected?
Pajarito above SR-4	2000	UF	INORGANIC	Ammonia as Nitrogen	3	2	1	2	1	3	1705	110	3300	Ephemeral	39.1	µg/L	Y
Pajarito above SR-4	2000	UF	INORGANIC	Antimony	2	1	1	1	1	2	0.621	0.621	0.621	Ephemeral	640	µg/L	Y
Pajarito above SR-4	2000	UF	INORGANIC	Arsenic	3	3		3		3	21.196	11.2	40.488	Ephemeral	9	µg/L	Y
Pajarito above SR-4	2000	UF	INORGANIC	Boron	2	2		2		2	235.0665	63	407.133	Ephemeral	5000	µg/L	Y
Pajarito above SR-4	2000	UF	INORGANIC	Cadmium	3	3		3		3	2.1333333	1.56	3.17	Ephemeral	2.1	µg/L	Y
Pajarito above SR-4	2000	UF	INORGANIC	Chemical Oxygen Demand	3	3		3		3	264666.67	131000	357000	Ephemeral	120	µg/L	Y
Pajarito above SR-4	2000	UF	INORGANIC	Chromium	3	3		3		3	34.199	20	61.997	Ephemeral	580	µg/L	Y
Pajarito above SR-4	2000	UF	INORGANIC	Cobalt	3	3		3		3	24.290333	9.39	52.381	Ephemeral	1000	µg/L	Y
Pajarito above SR-4	2000	UF	INORGANIC	Copper	3	3		3		3	69.963667	27.7	150.891	Ephemeral	14	µg/L	Y
Pajarito above SR-4	2000	UF	INORGANIC	Cyanide [Total]	3	2	1	2	1	3	46.085	7.17	85	Ephemeral	0.0636	µg/L	Y
Pajarito above SR-4	2000	UF	INORGANIC	Cyanide, Amenable to Chlorination	3		3		3	3				Ephemeral	0.0052	µg/L	N
Pajarito above SR-4	2000	UF	INORGANIC	Lead	3	3		3		3	13881.147	55	41523.3	Ephemeral	81.7	µg/L	Y
Pajarito above SR-4	2000	UF	INORGANIC	Magnesium	3	3		3		3	24338.443	9570	52945.3	Ephemeral	0.0636	µg/L	Y
Pajarito above SR-4	2000	UF	INORGANIC	Mercury	3	1	2	1	2	3	0.199	0.199	0.199	Ephemeral	0.77	µg/L	Y
Pajarito above SR-4	2000	UF	INORGANIC	Nickel	3	3		3		3	43.859	20	88.977	Ephemeral	469	µg/L	Y
Pajarito above SR-4	2000	UF	INORGANIC	Nitrate-Nitrite as Nitrogen	3	3		3		3	486.66667	110	940	Ephemeral	132	µg/L	Y
Pajarito above SR-4	2000	UF	INORGANIC	Selenium	3	2	1	2	1	3	10.8685	4.23	17.507	Ephemeral	5	µg/L	Y
Pajarito above SR-4	2000	UF	INORGANIC	Silver	3	3		3		3	3.096	1.35	6.198	Ephemeral	3.8	µg/L	Y
Pajarito above SR-4	2000	UF	INORGANIC	Thallium	3	1	2	1	2	3	0.561	0.561	0.561	Ephemeral	6.3	µg/L	Y
Pajarito above SR-4	2000	UF	INORGANIC	Vanadium	3	3		3		3	69.230667	40.6	125.692	Ephemeral	100	µg/L	Y
Pajarito above SR-4	2000	UF	INORGANIC	Zinc	3	3		3		3	295.96233	163	540.887	Ephemeral	120	µg/L	Y
Pajarito above SR-4	2000	UF	ORGANIC	Aroclor-1016	2		2		2	2				Ephemeral	0.00064	µg/L	N
Pajarito above SR-4	2000	UF	ORGANIC	Aroclor-1221	2		2		2	2				Ephemeral	0.00064	µg/L	N
Pajarito above SR-4	2000	UF	ORGANIC	Aroclor-1232	2		2		2	2				Ephemeral	0.00064	µg/L	N
Pajarito above SR-4	2000	UF	ORGANIC	Aroclor-1242	2		2		2	2				Ephemeral	0.00064	µg/L	N
Pajarito above SR-4	2000	UF	ORGANIC	Aroclor-1248	2		2		2	2				Ephemeral	0.00064	µg/L	N
Pajarito above SR-4	2000	UF	ORGANIC	Aroclor-1254	2		2		2	2				Ephemeral	0.00064	µg/L	N
Pajarito above SR-4	2000	UF	ORGANIC	Aroclor-1260	2		2		2	2				Ephemeral	0.00064	µg/L	N
Pajarito above SR-4	2000	UF	ORGANIC	Aroclor-1262	1		1		1	1				Ephemeral	0.00064	µg/L	N

Location ID	Year	Field Prep	RFI Class	Analyte Name	Number of Analyses	Detected	Nondetect	Count Detect > Wsal	Count Nd > Wsal	Total Analyses > Wsal	Average	Min	Max	Stream Type	Wsal	Units	Ever Detected?
Pajarito above SR-4	2000	UF	ORGANIC	Benzo[a]pyrene	2		2		2	2				Ephemeral	0.18	µg/L	N
Pajarito above SR-4	2000	UF	ORGANIC	Hexachlorobenzene	2		2		2	2				Ephemeral	0.0029	µg/L	N
Pajarito above SR-4	2000	UF	ORGANIC	Pentachlorophenol	2		2		2	2				Ephemeral	19	µg/L	N
Pajarito above SR-4	2000	UF	ORGANIC	RDX	2		2		2	2				Ephemeral	200	µg/L	N
Pajarito above SR-4	2000	UF	ORGANIC	Tetrachlorodibenzodioxin[2,3,7,8-]	2		2		2	2				Ephemeral	5.1E-08	µg/L	N
Pajarito above SR-4	2000	UF	ORGANIC	Tetrachloroethene	1		1		1	1				Ephemeral	33	µg/L	N
Pajarito above SR-4	2000	UF	ORGANIC	Trinitrotoluene[2,4,6-]	2		2		2	2				Ephemeral	20	µg/L	N
Pajarito above SR-4	2000	UF	RAD	Gross alpha	3	3		3		3	48.4	14.4	71.5	Ephemeral	15	pCi/L	Y
Pajarito above SR-4	2000	UF	RAD	Radium-226	2	1	1	1	1	2	0.6	0.6	0.6	Ephemeral	30	pCi/L	Y
Pajarito above SR-4	2000	UF	RAD	Radium-228	2	1	1	1	1	2	2.14	2.14	2.14	Ephemeral	30	pCi/L	Y
Pajarito above SR-4	2000	UF	RAD	Tritium	3	1	2	1	2	3	-148	-148	-148	Ephemeral	20000	pCi/L	Y
Pajarito above SR-4	2002	UF	INORGANIC	Ammonia as Nitrogen	1	1		1		1	180	180	180	Ephemeral	39.1	µg/L	Y
Pajarito above SR-4	2002	UF	INORGANIC	Arsenic	1	1		1		1	13.7	13.7	13.7	Ephemeral	9	µg/L	Y
Pajarito above SR-4	2002	UF	INORGANIC	Cadmium	1	1		1		1	3.85	3.85	3.85	Ephemeral	2.1	µg/L	Y
Pajarito above SR-4	2002	UF	INORGANIC	Chemical Oxygen Demand	1	1		1		1	129000	129000	129000	Ephemeral	120	µg/L	Y
Pajarito above SR-4	2002	UF	INORGANIC	Cyanide [Total]	1		1		1	1				Ephemeral	0.0636	µg/L	N
Pajarito above SR-4	2002	UF	INORGANIC	Lead	1	1		1		1	66.6	66.6	66.6	Ephemeral	81.7	µg/L	Y
Pajarito above SR-4	2002	UF	INORGANIC	Magnesium	1	1		1		1	11100	11100	11100	Ephemeral	0.0636	µg/L	Y
Pajarito above SR-4	2002	UF	INORGANIC	Mercury	1		1		1	1				Ephemeral	0.77	µg/L	N
Pajarito above SR-4	2002	UF	INORGANIC	Selenium	1	1		1		1	2	2	2	Ephemeral	5	µg/L	Y
Pajarito above SR-4	2002	UF	INORGANIC	Silver	1	1		1		1	2.71	2.71	2.71	Ephemeral	3.8	µg/L	Y
Pajarito above SR-4	2002	UF	ORGANIC	Aroclor-1016	1		1		1	1				Ephemeral	0.00064	µg/L	N
Pajarito above SR-4	2002	UF	ORGANIC	Aroclor-1221	1		1		1	1				Ephemeral	0.00064	µg/L	N
Pajarito above SR-4	2002	UF	ORGANIC	Aroclor-1232	1		1		1	1				Ephemeral	0.00064	µg/L	N
Pajarito above SR-4	2002	UF	ORGANIC	Aroclor-1242	1		1		1	1				Ephemeral	0.00064	µg/L	N
Pajarito above SR-4	2002	UF	ORGANIC	Aroclor-1248	1		1		1	1				Ephemeral	0.00064	µg/L	N
Pajarito above SR-4	2002	UF	ORGANIC	Aroclor-1254	1		1		1	1				Ephemeral	0.00064	µg/L	N
Pajarito above SR-4	2002	UF	ORGANIC	Aroclor-1260	1		1		1	1				Ephemeral	0.00064	µg/L	N
Pajarito above SR-4	2002	UF	ORGANIC	Aroclor-1262	1		1		1	1				Ephemeral	0.00064	µg/L	N

Location ID	Year	Field Prep	RFI Class	Analyte Name	Number of Analyses	Detected	Nondetect	Count Detect > Wsal	Count Nd > Wsal	Total Analyses > Wsal	Average	Min	Max	Stream Type	Wsal	Units	Ever Detected?
Pajarito above SR-4	2002	UF	ORGANIC	Benzo[a]pyrene	1		1		1	1				Ephemeral	0.18	µg/L	N
Pajarito above SR-4	2002	UF	ORGANIC	Hexachlorobenzene	1		1		1	1				Ephemeral	0.0029	µg/L	N
Pajarito above SR-4	2002	UF	ORGANIC	Trinitrotoluene[2,4,6-]	1		1		1	1				Ephemeral	20	µg/L	N
Pajarito above SR-4	1999	UF	INORGANIC	Aluminum	2	2		2		2	53542	23584	83500	Ephemeral	750	µg/L	Y
Pajarito above SR-4	1999	UF	INORGANIC	Ammonia	1	1		1		1	200	200	200	Ephemeral	39.1	µg/L	Y
Pajarito above SR-4	1999	UF	INORGANIC	Antimony	1	1		1		1	2649	2649	2649	Ephemeral	640	µg/L	Y
Pajarito above SR-4	1999	UF	INORGANIC	Arsenic	2	1	1	1	1	2	7	7	7	Ephemeral	9	µg/L	Y
Pajarito above SR-4	1999	UF	INORGANIC	Boron	1	1		1		1	30	30	30	Ephemeral	5000	µg/L	Y
Pajarito above SR-4	1999	UF	INORGANIC	Cadmium	2		2		2	2				Ephemeral	2.1	µg/L	N
Pajarito above SR-4	1999	UF	INORGANIC	Chemical Oxygen Demand	1	1		1		1	51800	51800	51800	Ephemeral	120	µg/L	Y
Pajarito above SR-4	1999	UF	INORGANIC	Chromium	1		1		1	1				Ephemeral	580	µg/L	N
Pajarito above SR-4	1999	UF	INORGANIC	Cobalt	1		1		1	1				Ephemeral	1000	µg/L	N
Pajarito above SR-4	1999	UF	INORGANIC	Copper	2	2		2		2	39	18	60	Ephemeral	14	µg/L	Y
Pajarito above SR-4	1999	UF	INORGANIC	Cyanide [Total]	1		1		1	1				Ephemeral	0.0636	µg/L	N
Pajarito above SR-4	1999	UF	INORGANIC	Lead	1		1		1	1				Ephemeral	81.7	µg/L	N
Pajarito above SR-4	1999	UF	INORGANIC	Magnesium	2	2		2		2	13479	7258	19700	Ephemeral	0.0636	µg/L	Y
Pajarito above SR-4	1999	UF	INORGANIC	Mercury	2	1	1	1	1	2	0.2	0.2	0.2	Ephemeral	0.77	µg/L	Y
Pajarito above SR-4	1999	UF	INORGANIC	Nickel	1		1		1	1				Ephemeral	469	µg/L	N
Pajarito above SR-4	1999	UF	INORGANIC	Selenium	2	1	1	1	1	2	50	50	50	Ephemeral	5	µg/L	Y
Pajarito above SR-4	1999	UF	INORGANIC	Silver	2		2		2	2				Ephemeral	3.8	µg/L	N
Pajarito above SR-4	1999	UF	INORGANIC	Thallium	1		1		1	1				Ephemeral	6.3	µg/L	N
Pajarito above SR-4	1999	UF	INORGANIC	Vanadium	1	1		1		1	30	30	30	Ephemeral	100	µg/L	Y
Pajarito above SR-4	1999	UF	INORGANIC	Zinc	2	2		2		2	179.5	109	250	Ephemeral	120	µg/L	Y
Pajarito above SR-4	1999	UF	ORGANIC	Aroclor-1016	1		1		1	1				Ephemeral	0.00064	µg/L	N
Pajarito above SR-4	1999	UF	ORGANIC	Aroclor-1221	1		1		1	1				Ephemeral	0.00064	µg/L	N
Pajarito above SR-4	1999	UF	ORGANIC	Aroclor-1232	1		1		1	1				Ephemeral	0.00064	µg/L	N
Pajarito above SR-4	1999	UF	ORGANIC	Aroclor-1242	1		1		1	1				Ephemeral	0.00064	µg/L	N
Pajarito above SR-4	1999	UF	ORGANIC	Aroclor-1248	1		1		1	1				Ephemeral	0.00064	µg/L	N
Pajarito above SR-4	1999	UF	ORGANIC	Aroclor-1254	1		1		1	1				Ephemeral	0.00064	µg/L	N

Location ID	Year	Field Prep	RFI Class	Analyte Name	Number of Analyses	Detected	Nondetect	Count Detect > Wsal	Count Nd > Wsal	Total Analyses > Wsal	Average	Min	Max	Stream Type	Wsal	Units	Ever Detected?
Pajarito above SR-4	1999	UF	ORGANIC	Aroclor-1260	1		1		1	1				Ephemeral	0.00064	µg/L	N
Pajarito above SR-4	1999	UF	ORGANIC	Benzo[a]pyrene	1		1		1	1				Ephemeral	0.18	µg/L	N
Pajarito above SR-4	1999	UF	ORGANIC	Hexachlorobenzene	1		1		1	1				Ephemeral	0.0029	µg/L	N
Pajarito above SR-4	1999	UF	ORGANIC	Pentachlorophenol	1		1		1	1				Ephemeral	19	µg/L	N
Pajarito above SR-4	1999	UF	ORGANIC	RDX	1		1		1	1				Ephemeral	200	µg/L	N
Pajarito above SR-4	1999	UF	ORGANIC	Trinitrotoluene[2,4,6-]	1		1		1	1				Ephemeral	20	µg/L	N
Pajarito above SR-4	1999	UF	RAD	Gross alpha	1	1		1		1	56.22	56.22	56.22	Ephemeral	15	pCi/L	Y
Pajarito above SR-4	1999	UF	RAD	Tritium	1	1		1		1	140	140	140	Ephemeral	20000	pCi/L	Y
Pajarito above SR-4	2001	UF	INORGANIC	Aluminum	4	4		4		4	155550	60800	265000	Ephemeral	750	µg/L	Y
Pajarito above SR-4	2001	UF	INORGANIC	Ammonia as Nitrogen	4	4		4		4	202.5	40	340	Ephemeral	39.1	µg/L	Y
Pajarito above SR-4	2001	UF	INORGANIC	Antimony	1		1		1	1				Ephemeral	640	µg/L	N
Pajarito above SR-4	2001	UF	INORGANIC	Arsenic	4	3	1	3	1	4	36.9	19.4	48	Ephemeral	9	µg/L	Y
Pajarito above SR-4	2001	UF	INORGANIC	Boron	4	3	1	3	1	4	60.233333	33.4	83	Ephemeral	5000	µg/L	Y
Pajarito above SR-4	2001	UF	INORGANIC	Cadmium	4	4		4		4	3.765	1.41	5.8	Ephemeral	2.1	µg/L	Y
Pajarito above SR-4	2001	UF	INORGANIC	Chemical Oxygen Demand	4	4		4		4	175350	58500	404000	Ephemeral	120	µg/L	Y
Pajarito above SR-4	2001	UF	INORGANIC	Chromium	4	4		4		4	78.775	29.8	134	Ephemeral	580	µg/L	Y
Pajarito above SR-4	2001	UF	INORGANIC	Cobalt	4	4		4		4	36.3	11.2	59.9	Ephemeral	1000	µg/L	Y
Pajarito above SR-4	2001	UF	INORGANIC	Copper	4	4		4		4	92.3	40.9	141	Ephemeral	14	µg/L	Y
Pajarito above SR-4	2001	UF	INORGANIC	Cyanide [Total]	4	2	2	2	2	4	10.365	7.63	13.1	Ephemeral	0.0636	µg/L	Y
Pajarito above SR-4	2001	UF	INORGANIC	Cyanide, Amenable to Chlorination	4		4		4	4				Ephemeral	0.0052	µg/L	N
Pajarito above SR-4	2001	UF	INORGANIC	Lead	4	4		4		4	165.875	83.1	271	Ephemeral	81.7	µg/L	Y
Pajarito above SR-4	2001	UF	INORGANIC	Magnesium	4	4		4		4	25575	12200	38900	Ephemeral	0.0636	µg/L	Y
Pajarito above SR-4	2001	UF	INORGANIC	Mercury	4		4		4	4				Ephemeral	0.77	µg/L	N
Pajarito above SR-4	2001	UF	INORGANIC	Nickel	4	4		4		4	79.625	26.8	132	Ephemeral	469	µg/L	Y
Pajarito above SR-4	2001	UF	INORGANIC	Nitrate-Nitrite as Nitrogen	4	4		4		4	857.5	420	1070	Ephemeral	132	µg/L	Y
Pajarito above SR-4	2001	UF	INORGANIC	Selenium	4	1	3	1	3	4	11.1	11.1	11.1	Ephemeral	5	µg/L	Y
Pajarito above SR-4	2001	UF	INORGANIC	Silver	4	3	1	3	1	4	24.488333	0.965	46.5	Ephemeral	3.8	µg/L	Y
Pajarito above SR-4	2001	UF	INORGANIC	Thallium	4	4		4		4	1.7595	0.696	2.94	Ephemeral	6.3	µg/L	Y
Pajarito above SR-4	2001	UF	INORGANIC	Vanadium	4	4		4		4	144.5	58.9	243	Ephemeral	100	µg/L	Y

Location ID	Year	Field Prep	RFI Class	Analyte Name	Number of Analyses	Detected	Nondetect	Count Detect > Wsal	Count Nd > Wsal	Total Analyses > Wsal	Average	Min	Max	Stream Type	Wsal	Units	Ever Detected?
Pajarito above SR-4	2001	UF	INORGANIC	Zinc	4	4		4		4	601.5	223	817	Ephemeral	120	µg/L	Y
Pajarito above SR-4	2001	UF	RAD	Gross alpha	4	4		4		4	116.225	42.9	147	Ephemeral	15	pCi/L	Y
Pajarito above SR-4	2001	UF	RAD	Radium-226	4	4		4		4	4.4175	1.41	6.24	Ephemeral	30	pCi/L	Y
Pajarito above SR-4	2001	UF	RAD	Radium-228	4	3	1	3	1	4	5.43	3.2	6.64	Ephemeral	30	pCi/L	Y
Pajarito above SR-4	2001	UF	RAD	Tritium	4	1	3	1	3	4	186	186	186	Ephemeral	20000	pCi/L	Y
Pajarito above SR-4	2005	UF	INORGANIC	Aluminum	1	1		1		1	17300	17300	17300	Ephemeral	750	µg/L	Y
Pajarito above SR-4	2005	UF	INORGANIC	Antimony	1	1		1		1	0.8	0.8	0.8	Ephemeral	640	µg/L	Y
Pajarito above SR-4	2005	UF	INORGANIC	Arsenic	1	1		1		1	6.1	6.1	6.1	Ephemeral	9	µg/L	Y
Pajarito above SR-4	2005	UF	INORGANIC	Cadmium	1		1		1	1				Ephemeral	2.1	µg/L	N
Pajarito above SR-4	2005	UF	INORGANIC	Chromium	1		1		1	1				Ephemeral	580	µg/L	N
Pajarito above SR-4	2005	UF	INORGANIC	Cobalt	1		1		1	1				Ephemeral	1000	µg/L	N
Pajarito above SR-4	2005	UF	INORGANIC	Copper	1		1		1	1				Ephemeral	14	µg/L	N
Pajarito above SR-4	2005	UF	INORGANIC	Lead	1	1		1		1	12.2	12.2	12.2	Ephemeral	81.7	µg/L	Y
Pajarito above SR-4	2005	UF	INORGANIC	Magnesium	1	1		1		1	6180	6180	6180	Ephemeral	0.0636	µg/L	Y
Pajarito above SR-4	2005	UF	INORGANIC	Mercury	1		1		1	1				Ephemeral	0.77	µg/L	N
Pajarito above SR-4	2005	UF	INORGANIC	Nickel	1	1		1		1	7.5	7.5	7.5	Ephemeral	469	µg/L	Y
Pajarito above SR-4	2005	UF	INORGANIC	Selenium	1		1		1	1				Ephemeral	5	µg/L	N
Pajarito above SR-4	2005	UF	INORGANIC	Silver	1	1		1		1	0.6	0.6	0.6	Ephemeral	3.8	µg/L	Y
Pajarito above SR-4	2005	UF	INORGANIC	Thallium	1		1		1	1				Ephemeral	6.3	µg/L	N
Pajarito above SR-4	2005	UF	INORGANIC	Vanadium	1	1		1		1	17.9	17.9	17.9	Ephemeral	100	µg/L	Y
Pajarito above SR-4	2005	UF	INORGANIC	Zinc	1	1		1		1	48.8	48.8	48.8	Ephemeral	120	µg/L	Y
Pajarito above SR-4	2005	UF	ORGANIC	Tetrachlorodibenzodioxin[2,3,7,8-]	1		1		1	1				Ephemeral	5.1E-08	µg/L	N
Pajarito above SR-4	2006	UF	INORGANIC	Aluminum	1	1		1		1	62300	62300	62300	Ephemeral	750	µg/L	Y
Pajarito above SR-4	2006	UF	INORGANIC	Ammonia as Nitrogen	1	1		1		1	261	261	261	Ephemeral	39.1	µg/L	Y
Pajarito above SR-4	2006	UF	INORGANIC	Antimony	1		1		1	1				Ephemeral	640	µg/L	N
Pajarito above SR-4	2006	UF	INORGANIC	Arsenic	1	1		1		1	11.7	11.7	11.7	Ephemeral	9	µg/L	Y
Pajarito above SR-4	2006	UF	INORGANIC	Cadmium	1	1		1		1	1.9	1.9	1.9	Ephemeral	2.1	µg/L	Y
Pajarito above SR-4	2006	UF	INORGANIC	Chemical Oxygen Demand	1	1		1		1	173000	173000	173000	Ephemeral	120	µg/L	Y
Pajarito above SR-4	2006	UF	INORGANIC	Chromium	1	1		1		1	27	27	27	Ephemeral	580	µg/L	Y

Location ID	Year	Field Prep	RFI Class	Analyte Name	Number of Analyses	Detected	Nondetect	Count Detect > Wsal	Count Nd > Wsal	Total Analyses > Wsal	Average	Min	Max	Stream Type	Wsal	Units	Ever Detected?
Pajarito above SR-4	2006	UF	INORGANIC	Cobalt	1	1		1		1	18.8	18.8	18.8	Ephemeral	1000	µg/L	Y
Pajarito above SR-4	2006	UF	INORGANIC	Copper	1	1		1		1	53.8	53.8	53.8	Ephemeral	14	µg/L	Y
Pajarito above SR-4	2006	UF	INORGANIC	Cyanide [Total]	1		1		1	1				Ephemeral	0.0636	µg/L	N
Pajarito above SR-4	2006	UF	INORGANIC	Cyanide, Amenable to Chlorination	1		1		1	1				Ephemeral	0.0052	µg/L	N
Pajarito above SR-4	2006	UF	INORGANIC	Lead	1	1		1		1	96.2	96.2	96.2	Ephemeral	81.7	µg/L	Y
Pajarito above SR-4	2006	UF	INORGANIC	Magnesium	1	1		1		1	11300	11300	11300	Ephemeral	0.0636	µg/L	Y
Pajarito above SR-4	2006	UF	INORGANIC	Mercury	1		1		1	1				Ephemeral	0.77	µg/L	N
Pajarito above SR-4	2006	UF	INORGANIC	Nickel	1	1		1		1	31.1	31.1	31.1	Ephemeral	469	µg/L	Y
Pajarito above SR-4	2006	UF	INORGANIC	Selenium	1		1		1	1				Ephemeral	5	µg/L	N
Pajarito above SR-4	2006	UF	INORGANIC	Silver	1	1		1		1	1.3	1.3	1.3	Ephemeral	3.8	µg/L	Y
Pajarito above SR-4	2006	UF	INORGANIC	Thallium	1	1		1		1	0.76	0.76	0.76	Ephemeral	6.3	µg/L	Y
Pajarito above SR-4	2006	UF	INORGANIC	Vanadium	1	1		1		1	71.5	71.5	71.5	Ephemeral	100	µg/L	Y
Pajarito above SR-4	2006	UF	INORGANIC	Zinc	1	1		1		1	251	251	251	Ephemeral	120	µg/L	Y
Pajarito above SR-4	2006	UF	RAD	Gross alpha	1	1		1		1	86.4	86.4	86.4	Ephemeral	15	pCi/L	Y
Pajarito above SR-4	2006	UF	RAD	Radium-226	1	1		1		1	3.65	3.65	3.65	Ephemeral	30	pCi/L	Y
Pajarito above SR-4	2004	UF	INORGANIC	Aluminum	1	1		1		1	8130	8130	8130	Ephemeral	750	µg/L	Y
Pajarito above SR-4	2004	UF	INORGANIC	Ammonia as Nitrogen	1	1		1		1	245	245	245	Ephemeral	39.1	µg/L	Y
Pajarito above SR-4	2004	UF	INORGANIC	Antimony	1		1		1	1				Ephemeral	640	µg/L	N
Pajarito above SR-4	2004	UF	INORGANIC	Arsenic	2	1	1	1	1	2	2.8	2.8	2.8	Ephemeral	9	µg/L	Y
Pajarito above SR-4	2004	UF	INORGANIC	Boron	1	1		1		1	36.4	36.4	36.4	Ephemeral	5000	µg/L	Y
Pajarito above SR-4	2004	UF	INORGANIC	Cadmium	2	2		2		2	0.2125	0.182	0.243	Ephemeral	2.1	µg/L	Y
Pajarito above SR-4	2004	UF	INORGANIC	Chemical Oxygen Demand	1	1		1		1	66400	66400	66400	Ephemeral	120	µg/L	Y
Pajarito above SR-4	2004	UF	INORGANIC	Chromium	1	1		1		1	2.25	2.25	2.25	Ephemeral	580	µg/L	Y
Pajarito above SR-4	2004	UF	INORGANIC	Cobalt	1	1		1		1	1.79	1.79	1.79	Ephemeral	1000	µg/L	Y
Pajarito above SR-4	2004	UF	INORGANIC	Copper	1	1		1		1	7.93	7.93	7.93	Ephemeral	14	µg/L	Y
Pajarito above SR-4	2004	UF	INORGANIC	Cyanide [Total]	1	1		1		1	4.28	4.28	4.28	Ephemeral	0.0636	µg/L	Y
Pajarito above SR-4	2004	UF	INORGANIC	Lead	2	2		2		2	4.895	2.86	6.93	Ephemeral	81.7	µg/L	Y
Pajarito above SR-4	2004	UF	INORGANIC	Magnesium	2	2		2		2	6675	6300	7050	Ephemeral	0.0636	µg/L	Y
Pajarito above SR-4	2004	UF	INORGANIC	Mercury	1		1		1	1				Ephemeral	0.77	µg/L	N

Location ID	Year	Field Prep	RFI Class	Analyte Name	Number of Analyses	Detected	Nondetect	Count Detect > Wsal	Count Nd > Wsal	Total Analyses > Wsal	Average	Min	Max	Stream Type	Wsal	Units	Ever Detected?
Pajarito above SR-4	2004	UF	INORGANIC	Nickel	1	1		1		1	5.08	5.08	5.08	Ephemeral	469	µg/L	Y
Pajarito above SR-4	2004	UF	INORGANIC	Selenium	2	1	1	1	1	2	1.23	1.23	1.23	Ephemeral	5	µg/L	Y
Pajarito above SR-4	2004	UF	INORGANIC	Silver	2		2		2	2				Ephemeral	3.8	µg/L	N
Pajarito above SR-4	2004	UF	INORGANIC	Thallium	1		1		1	1				Ephemeral	6.3	µg/L	N
Pajarito above SR-4	2004	UF	INORGANIC	Vanadium	1	1		1		1	7.87	7.87	7.87	Ephemeral	100	µg/L	Y
Pajarito above SR-4	2004	UF	INORGANIC	Zinc	1	1		1		1	33.1	33.1	33.1	Ephemeral	120	µg/L	Y
Pajarito above SR-4	2004	UF	ORGANIC	Aroclor-1016	1		1		1	1				Ephemeral	0.00064	µg/L	N
Pajarito above SR-4	2004	UF	ORGANIC	Aroclor-1221	1		1		1	1				Ephemeral	0.00064	µg/L	N
Pajarito above SR-4	2004	UF	ORGANIC	Aroclor-1232	1		1		1	1				Ephemeral	0.00064	µg/L	N
Pajarito above SR-4	2004	UF	ORGANIC	Aroclor-1242	1		1		1	1				Ephemeral	0.00064	µg/L	N
Pajarito above SR-4	2004	UF	ORGANIC	Aroclor-1248	1		1		1	1				Ephemeral	0.00064	µg/L	N
Pajarito above SR-4	2004	UF	ORGANIC	Aroclor-1254	1		1		1	1				Ephemeral	0.00064	µg/L	N
Pajarito above SR-4	2004	UF	ORGANIC	Aroclor-1260	1		1		1	1				Ephemeral	0.00064	µg/L	N
Pajarito above SR-4	2004	UF	ORGANIC	Aroclor-1262	1		1		1	1				Ephemeral	0.00064	µg/L	N
Pajarito above SR-4	2004	UF	ORGANIC	RDX	1		1		1	1				Ephemeral	200	µg/L	N
Pajarito above SR-4	2004	UF	ORGANIC	Tetrachlorodibenzodioxin[2,3,7,8-]	1		1		1	1				Ephemeral	5.1E-08	µg/L	N
Pajarito above SR-4	2004	UF	ORGANIC	Trinitrotoluene[2,4,6-]	1		1		1	1				Ephemeral	20	µg/L	N
Pajarito above SR-4	2004	UF	RAD	Gross alpha	1	1		1		1	1.5	1.5	1.5	Ephemeral	15	pCi/L	Y
Pajarito above SR-4	2004	UF	RAD	Tritium	1	1		1		1	209	209	209	Ephemeral	20000	pCi/L	Y
Pajarito above SR-4	2007	UF	INORGANIC	Aluminum	2	2		2		2	7335	5490	9180	Ephemeral	750	ug/L	Y
Pajarito above SR-4	2007	UF	INORGANIC	Antimony	2	1	1	1	1	2	0.8	0.8	0.8	Ephemeral	640	µg/L	Y
Pajarito above SR-4	2007	UF	INORGANIC	Arsenic	2	2		2		2	13.05	5.7	20.4	Ephemeral	9	µg/L	Y
Pajarito above SR-4	2007	UF	INORGANIC	Cadmium	2	2		2		2	0.42	0.34	0.5	Ephemeral	2.1	µg/L	Y
Pajarito above SR-4	2007	UF	INORGANIC	Chromium	2	2		2		2	10.45	1.9	19	Ephemeral	580	µg/L	Y
Pajarito above SR-4	2007	UF	INORGANIC	Cobalt	2	2		2		2	2.8	2.4	3.2	Ephemeral	1000	µg/L	Y
Pajarito above SR-4	2007	UF	INORGANIC	Copper	2	2		2		2	8.45	7.1	9.8	Ephemeral	14	µg/L	Y
Pajarito above SR-4	2007	UF	INORGANIC	Cyanide [Total]	2		2		2	2				Ephemeral	0.0636	µg/L	N
Pajarito above SR-4	2007	UF	INORGANIC	Cyanide, Amenable to Chlorination	2		2		2	2				Ephemeral	0.0052	µg/L	N
Pajarito above SR-4	2007	UF	INORGANIC	Lead	2	2		2		2	23.85	9.8	37.9	Ephemeral	81.7	µg/L	Y

Location ID	Year	Field Prep	RFI Class	Analyte Name	Number of Analyses	Detected	Nondetect	Count Detect > Wsal	Count Nd > Wsal	Total Analyses > Wsal	Average	Min	Max	Stream Type	Wsal	Units	Ever Detected?
Pajarito above SR-4	2007	UF	INORGANIC	Magnesium	2	2		2		2	8470	6240	10700	Ephemeral	0.0636	µg/L	Y
Pajarito above SR-4	2007	UF	INORGANIC	Mercury	2		2		2	2				Ephemeral	0.77	µg/L	N
Pajarito above SR-4	2007	UF	INORGANIC	Nickel	2	2		2		2	10.1	4.7	15.5	Ephemeral	469	µg/L	Y
Pajarito above SR-4	2007	UF	INORGANIC	Selenium	2		2		2	2				Ephemeral	5	µg/L	N
Pajarito above SR-4	2007	UF	INORGANIC	Silver	2	1	1	1	1	2	0.58	0.58	0.58	Ephemeral	3.8	µg/L	Y
Pajarito above SR-4	2007	UF	INORGANIC	Thallium	2		2		2	2				Ephemeral	6.3	µg/L	N
Pajarito above SR-4	2007	UF	INORGANIC	Vanadium	2	2		2		2	11.85	7.9	15.8	Ephemeral	100	µg/L	Y
Pajarito above SR-4	2007	UF	INORGANIC	Zinc	2	2		2		2	45.25	38.1	52.4	Ephemeral	120	µg/L	Y
Pajarito above SR-4	2007	UF	ORGANIC	Aroclor-1016	2		2		2	2				Ephemeral	0.00064	µg/L	N
Pajarito above SR-4	2007	UF	ORGANIC	Aroclor-1221	2		2		2	2				Ephemeral	0.00064	µg/L	N
Pajarito above SR-4	2007	UF	ORGANIC	Aroclor-1232	2		2		2	2				Ephemeral	0.00064	µg/L	N
Pajarito above SR-4	2007	UF	ORGANIC	Aroclor-1242	2		2		2	2				Ephemeral	0.00064	µg/L	N
Pajarito above SR-4	2007	UF	ORGANIC	Aroclor-1248	2		2		2	2				Ephemeral	0.00064	µg/L	N
Pajarito above SR-4	2007	UF	ORGANIC	Aroclor-1254	2		2		2	2				Ephemeral	0.00064	µg/L	N
Pajarito above SR-4	2007	UF	ORGANIC	Aroclor-1260	2		2		2	2				Ephemeral	0.00064	µg/L	N
Pajarito above SR-4	2007	UF	ORGANIC	Aroclor-1262	2		2		2	2				Ephemeral	0.00064	µg/L	N
Pajarito above SR-4	2007	UF	ORGANIC	RDX	2		2		2	2				Ephemeral	200	µg/L	N
Pajarito above SR-4	2007	UF	ORGANIC	Tetrachlorodibenzodioxin[2,3,7,8-]	2		2		2	2				Ephemeral	5.1E-08	µg/L	N
Pajarito above SR-4	2007	UF	ORGANIC	Trinitrotoluene[2,4,6-]	2		2		2	2				Ephemeral	20	µg/L	N
Pajarito above SR-4	2007	UF	RAD	Tritium	1		1		1	1				Ephemeral	20000	pCi/L	N
Pajarito above SR-4	2008	UF	INORGANIC	Aluminum	1	1		1		1	4060	4060	4060	Ephemeral	750	µg/L	Y
Pajarito above SR-4	2008	UF	INORGANIC	Antimony	1		1		1	1				Ephemeral	640	µg/L	N
Pajarito above SR-4	2008	UF	INORGANIC	Arsenic	1		1		1	1				Ephemeral	9	µg/L	N
Pajarito above SR-4	2008	UF	INORGANIC	Cadmium	1		1		1	1				Ephemeral	2.1	µg/L	N
Pajarito above SR-4	2008	UF	INORGANIC	Chromium	1		1		1	1				Ephemeral	580	µg/L	N
Pajarito above SR-4	2008	UF	INORGANIC	Cobalt	1		1		1	1				Ephemeral	1000	µg/L	N
Pajarito above SR-4	2008	UF	INORGANIC	Copper	1		1		1	1				Ephemeral	14	µg/L	N
Pajarito above SR-4	2008	UF	INORGANIC	Cyanide [Total]	1	1		1		1	2.78	2.78	2.78	Ephemeral	0.0636	µg/L	Y
Pajarito above SR-4	2008	UF	INORGANIC	Cyanide, Amenable to Chlorination	1		1		1	1				Ephemeral	0.0052	µg/L	N

Location ID	Year	Field Prep	RFI Class	Analyte Name	Number of Analyses	Detected	Nondetect	Count Detect > Wsal	Count Nd > Wsal	Total Analyses > Wsal	Average	Min	Max	Stream Type	Wsal	Units	Ever Detected?
Pajarito above SR-4	2008	UF	INORGANIC	Lead	1	1		1		1	1.7	1.7	1.7	Ephemeral	81.7	µg/L	Y
Pajarito above SR-4	2008	UF	INORGANIC	Magnesium	1	1		1		1	5570	5570	5570	Ephemeral	0.0636	µg/L	Y
Pajarito above SR-4	2008	UF	INORGANIC	Nickel	1	1		1		1	2	2	2	Ephemeral	469	µg/L	Y
Pajarito above SR-4	2008	UF	INORGANIC	Selenium	1		1		1	1				Ephemeral	5	µg/L	N
Pajarito above SR-4	2008	UF	INORGANIC	Silver	1	1		1		1	0.23	0.23	0.23	Ephemeral	3.8	µg/L	Y
Pajarito above SR-4	2008	UF	INORGANIC	Thallium	1		1		1	1				Ephemeral	6.3	µg/L	N
Pajarito above SR-4	2008	UF	INORGANIC	Vanadium	1	1		1		1	4	4	4	Ephemeral	100	µg/L	Y
Pajarito above SR-4	2008	UF	INORGANIC	Zinc	1	1		1		1	11.2	11.2	11.2	Ephemeral	120	µg/L	Y
Pajarito above SR-4	2008	UF	RAD	Gross alpha	1		1		1	1				Ephemeral	15	pCi/L	N
Pajarito above SR-4	2008	UF	RAD	Radium-226	1	1		1		1	0.995	0.995	0.995	Ephemeral	30	pCi/L	Y
Pajarito above SR-4	2008	UF	RAD	Tritium	1		1		1	1				Ephemeral	20000	pCi/L	N
Pajarito Retention Pond	2000	F	INORGANIC	Nitrate-Nitrite as Nitrogen	1		1		1	1				Perennial	132	µg/L	N
Pajarito Retention Pond	2000	UF	INORGANIC	Aluminum	1	1		1		1	14900	14900	14900	Perennial	87	µg/L	Y
Pajarito Retention Pond	2000	UF	INORGANIC	Ammonia as Nitrogen	1	1		1		1	80	80	80	Perennial	8.19	µg/L	Y
Pajarito Retention Pond	2000	UF	INORGANIC	Antimony	1		1		1	1				Perennial	640	µg/L	N
Pajarito Retention Pond	2000	UF	INORGANIC	Arsenic	1	1		1		1	9.07	9.07	9.07	Perennial	9	µg/L	Y
Pajarito Retention Pond	2000	UF	INORGANIC	Boron	1	1		1		1	47.3	47.3	47.3	Perennial	5000	µg/L	Y
Pajarito Retention Pond	2000	UF	INORGANIC	Cadmium	1	1		1		1	0.393	0.393	0.393	Perennial	0.28	µg/L	Y
Pajarito Retention Pond	2000	UF	INORGANIC	Chemical Oxygen Demand	1	1		1		1	172000	172000	172000	Perennial	120	µg/L	Y
Pajarito Retention Pond	2000	UF	INORGANIC	Chromium	1	1		1		1	6.64	6.64	6.64	Perennial	77	µg/L	Y
Pajarito Retention Pond	2000	UF	INORGANIC	Cobalt	1	1		1		1	6.77	6.77	6.77	Perennial	1000	µg/L	Y
Pajarito Retention Pond	2000	UF	INORGANIC	Copper	1	1		1		1	14	14	14	Perennial	9.4	µg/L	Y
Pajarito Retention Pond	2000	UF	INORGANIC	Cyanide [Total]	1	1		1		1	7.97	7.97	7.97	Perennial	0.0636	µg/L	Y
Pajarito Retention Pond	2000	UF	INORGANIC	Cyanide, Amenable to Chlorination	1	1		1		1	4.55	4.55	4.55	Perennial	0.0052	µg/L	Y
Pajarito Retention Pond	2000	UF	INORGANIC	Lead	1	1		1		1	23.7	23.7	23.7	Perennial	3.2	µg/L	Y
Pajarito Retention Pond	2000	UF	INORGANIC	Magnesium	1	1		1		1	8870	8870	8870	Perennial	0.0636	µg/L	Y
Pajarito Retention Pond	2000	UF	INORGANIC	Mercury	1	1		1		1	0.136	0.136	0.136	Perennial	0.77	µg/L	Y
Pajarito Retention Pond	2000	UF	INORGANIC	Nickel	1	1		1		1	8.45	8.45	8.45	Perennial	52	µg/L	Y
Pajarito Retention Pond	2000	UF	INORGANIC	Nitrate-Nitrite as Nitrogen	1		1		1	1				Perennial	132	µg/L	N

Location ID	Year	Field Prep	RFI Class	Analyte Name	Number of Analyses	Detected	Nondetect	Count Detect > Wsal	Count Nd > Wsal	Total Analyses > Wsal	Average	Min	Max	Stream Type	Wsal	Units	Ever Detected?
Pajarito Retention Pond	2000	UF	INORGANIC	Selenium	1	1		1		1	2.41	2.41	2.41	Perennial	5	µg/L	Y
Pajarito Retention Pond	2000	UF	INORGANIC	Silver	1		1		1	1				Perennial	3.8	µg/L	N
Pajarito Retention Pond	2000	UF	INORGANIC	Thallium	1	1		1		1	0.13	0.13	0.13	Perennial	6.3	µg/L	Y
Pajarito Retention Pond	2000	UF	INORGANIC	Vanadium	1	1		1		1	19.6	19.6	19.6	Perennial	100	µg/L	Y
Pajarito Retention Pond	2000	UF	INORGANIC	Zinc	1	1		1		1	49.5	49.5	49.5	Perennial	120	µg/L	Y
Pajarito Retention Pond	2000	UF	RAD	Gross alpha	1	1		1		1	16.9	16.9	16.9	Perennial	15	pCi/L	Y
Pajarito Retention Pond	2000	UF	RAD	Tritium	1	1		1		1	-116	-116	-116	Perennial	20000	pCi/L	Y
Starmer's Gulch above SR-501	2000	UF	INORGANIC	Aluminum	1	1		1		1	63700	63700	63700	Ephemeral	750	µg/L	Y
Starmer's Gulch above SR-501	2000	UF	INORGANIC	Ammonia as Nitrogen	1	1		1		1	720	720	720	Ephemeral	39.1	µg/L	Y
Starmer's Gulch above SR-501	2000	UF	INORGANIC	Antimony	1		1		1	1				Ephemeral	640	µg/L	N
Starmer's Gulch above SR-501	2000	UF	INORGANIC	Arsenic	1	1		1		1	14.2	14.2	14.2	Ephemeral	9	µg/L	Y
Starmer's Gulch above SR-501	2000	UF	INORGANIC	Boron	1	1		1		1	71	71	71	Ephemeral	5000	µg/L	Y
Starmer's Gulch above SR-501	2000	UF	INORGANIC	Cadmium	1	1		1		1	4.27	4.27	4.27	Ephemeral	2.1	µg/L	Y
Starmer's Gulch above SR-501	2000	UF	INORGANIC	Chemical Oxygen Demand	1	1		1		1	851000	851000	851000	Ephemeral	120	µg/L	Y
Starmer's Gulch above SR-501	2000	UF	INORGANIC	Chromium	1	1		1		1	22	22	22	Ephemeral	580	µg/L	Y
Starmer's Gulch above SR-501	2000	UF	INORGANIC	Cobalt	1	1		1		1	65.6	65.6	65.6	Ephemeral	1000	µg/L	Y
Starmer's Gulch above SR-501	2000	UF	INORGANIC	Copper	1	1		1		1	26.3	26.3	26.3	Ephemeral	14	µg/L	Y
Starmer's Gulch above SR-501	2000	UF	INORGANIC	Cyanide [Total]	1	1		1		1	10.3	10.3	10.3	Ephemeral	0.0636	µg/L	Y
Starmer's Gulch above SR-501	2000	UF	INORGANIC	Cyanide, Amenable to Chlorination	1		1		1	1				Ephemeral	0.0052	µg/L	N
Starmer's Gulch above SR-501	2000	UF	INORGANIC	Lead	1	1		1		1	64.9	64.9	64.9	Ephemeral	81.7	µg/L	Y
Starmer's Gulch above SR-501	2000	UF	INORGANIC	Magnesium	1	1		1		1	19400	19400	19400	Ephemeral	0.0636	µg/L	Y
Starmer's Gulch above SR-501	2000	UF	INORGANIC	Mercury	1		1		1	1				Ephemeral	0.77	µg/L	N
Starmer's Gulch above SR-501	2000	UF	INORGANIC	Nickel	1	1		1		1	44.6	44.6	44.6	Ephemeral	469	µg/L	Y
Starmer's Gulch above SR-501	2000	UF	INORGANIC	Nitrate-Nitrite as Nitrogen	1	1		1		1	100	100	100	Ephemeral	132	µg/L	Y
Starmer's Gulch above SR-501	2000	UF	INORGANIC	Selenium	1		1		1	1				Ephemeral	5	µg/L	N
Starmer's Gulch above SR-501	2000	UF	INORGANIC	Silver	1		1		1	1				Ephemeral	3.8	µg/L	N
Starmer's Gulch above SR-501	2000	UF	INORGANIC	Thallium	1	1		1		1	0.288	0.288	0.288	Ephemeral	6.3	µg/L	Y
Starmer's Gulch above SR-501	2000	UF	INORGANIC	Vanadium	1	1		1		1	66.4	66.4	66.4	Ephemeral	100	µg/L	Y
Starmer's Gulch above SR-501	2000	UF	INORGANIC	Zinc	1	1		1		1	454	454	454	Ephemeral	120	µg/L	Y

Location ID	Year	Field Prep	RFI Class	Analyte Name	Number of Analyses	Detected	Nondetect	Count Detect > Wsal	Count Nd > Wsal	Total Analyses > Wsal	Average	Min	Max	Stream Type	Wsal	Units	Ever Detected?
Starmer's Gulch above SR-501	2000	UF	ORGANIC	Benzo[a]pyrene	1		1		1	1				Ephemeral	0.18	µg/L	N
Starmer's Gulch above SR-501	2000	UF	ORGANIC	Hexachlorobenzene	1		1		1	1				Ephemeral	0.0029	µg/L	N
Starmer's Gulch above SR-501	2000	UF	ORGANIC	Pentachlorophenol	1		1		1	1				Ephemeral	19	µg/L	N
Starmer's Gulch above SR-501	2000	UF	ORGANIC	Tetrachlorodibenzodioxin[2,3,7,8-]	1		1		1	1				Ephemeral	5.1E-08	µg/L	N
Starmer's Gulch above SR-501	2000	UF	ORGANIC	Tetrachloroethene	1		1		1	1				Ephemeral	33	µg/L	N
Starmer's Gulch above SR-501	2000	UF	RAD	Gross alpha	1	1		1		1	161	161	161	Ephemeral	15	pCi/L	Y
Starmer's Gulch above SR-501	2000	UF	RAD	Radium-226	1	1		1		1	9.2	9.2	9.2	Ephemeral	30	pCi/L	Y
Starmer's Gulch above SR-501	2000	UF	RAD	Radium-228	1		1		1	1				Ephemeral	30	pCi/L	N
Starmer's Gulch above SR-501	2000	UF	RAD	Tritium	1		1		1	1				Ephemeral	20000	pCi/L	N
TA-18 Culvert	2000	UF	INORGANIC	Aluminum	1	1		1		1	241784	241784	241784	Ephemeral	750	µg/L	Y
TA-18 Culvert	2000	UF	INORGANIC	Ammonia as Nitrogen	1	1		1		1	5100	5100	5100	Ephemeral	39.1	µg/L	Y
TA-18 Culvert	2000	UF	INORGANIC	Arsenic	1	1		1		1	74.902	74.902	74.902	Ephemeral	9	µg/L	Y
TA-18 Culvert	2000	UF	INORGANIC	Boron	1	1		1		1	495.422	495.422	495.422	Ephemeral	5000	µg/L	Y
TA-18 Culvert	2000	UF	INORGANIC	Cadmium	1	1		1		1	10.396	10.396	10.396	Ephemeral	2.1	µg/L	Y
TA-18 Culvert	2000	UF	INORGANIC	Chemical Oxygen Demand	1	1		1		1	385000	385000	385000	Ephemeral	120	µg/L	Y
TA-18 Culvert	2000	UF	INORGANIC	Chromium	1	1		1		1	194.18	194.18	194.18	Ephemeral	580	µg/L	Y
TA-18 Culvert	2000	UF	INORGANIC	Cobalt	1	1		1		1	140.884	140.884	140.884	Ephemeral	1000	µg/L	Y
TA-18 Culvert	2000	UF	INORGANIC	Copper	1	1		1		1	455.433	455.433	455.433	Ephemeral	14	µg/L	Y
TA-18 Culvert	2000	UF	INORGANIC	Cyanide [Total]	1	1		1		1	175	175	175	Ephemeral	0.0636	µg/L	Y
TA-18 Culvert	2000	UF	INORGANIC	Cyanide, Amenable to Chlorination	1		1		1	1				Ephemeral	0.0052	µg/L	N
TA-18 Culvert	2000	UF	INORGANIC	Lead	1	1		1		1	689.883	689.883	689.883	Ephemeral	81.7	µg/L	Y
TA-18 Culvert	2000	UF	INORGANIC	Magnesium	1	1		1		1	81088.87	81088.9	81088.9	Ephemeral	0.0636	µg/L	Y
TA-18 Culvert	2000	UF	INORGANIC	Mercury	1	1		1		1	1.188	1.188	1.188	Ephemeral	0.77	µg/L	Y
TA-18 Culvert	2000	UF	INORGANIC	Nickel	1	1		1		1	240.849	240.849	240.849	Ephemeral	469	µg/L	Y
TA-18 Culvert	2000	UF	INORGANIC	Nitrate-Nitrite as Nitrogen	1	1		1		1	520	520	520	Ephemeral	132	µg/L	Y
TA-18 Culvert	2000	UF	INORGANIC	Selenium	1	1		1		1	56.693	56.693	56.693	Ephemeral	5	µg/L	Y
TA-18 Culvert	2000	UF	INORGANIC	Silver	1	1		1		1	13.121	13.121	13.121	Ephemeral	3.8	µg/L	Y
TA-18 Culvert	2000	UF	INORGANIC	Thallium	1	1		1		1	20.24	20.24	20.24	Ephemeral	6.3	µg/L	Y
TA-18 Culvert	2000	UF	INORGANIC	Vanadium	1	1		1		1	408.127	408.127	408.127	Ephemeral	100	µg/L	Y

Location ID	Year	Field Prep	RFI Class	Analyte Name	Number of Analyses	Detected	Nondetect	Count Detect > Wsal	Count Nd > Wsal	Total Analyses > Wsal	Average	Min	Max	Stream Type	Wsal	Units	Ever Detected?
TA-18 Culvert	2000	UF	INORGANIC	Zinc	1	1		1		1	1574.933	1574.93	1574.93	Ephemeral	120	µg/L	Y
TA-18 Culvert	2000	UF	ORGANIC	Aroclor-1016	1		1		1	1				Ephemeral	0.00064	µg/L	N
TA-18 Culvert	2000	UF	ORGANIC	Aroclor-1221	1		1		1	1				Ephemeral	0.00064	µg/L	N
TA-18 Culvert	2000	UF	ORGANIC	Aroclor-1232	1		1		1	1				Ephemeral	0.00064	µg/L	N
TA-18 Culvert	2000	UF	ORGANIC	Aroclor-1242	1		1		1	1				Ephemeral	0.00064	µg/L	N
TA-18 Culvert	2000	UF	ORGANIC	Aroclor-1248	1		1		1	1				Ephemeral	0.00064	µg/L	N
TA-18 Culvert	2000	UF	ORGANIC	Aroclor-1254	1		1		1	1				Ephemeral	0.00064	µg/L	N
TA-18 Culvert	2000	UF	ORGANIC	Aroclor-1260	1		1		1	1				Ephemeral	0.00064	µg/L	N
TA-18 Culvert	2000	UF	ORGANIC	Benzo[a]pyrene	1		1		1	1				Ephemeral	0.18	µg/L	N
TA-18 Culvert	2000	UF	ORGANIC	Hexachlorobenzene	1		1		1	1				Ephemeral	0.0029	µg/L	N
TA-18 Culvert	2000	UF	ORGANIC	Pentachlorophenol	1		1		1	1				Ephemeral	19	µg/L	N
TA-18 Culvert	2000	UF	RAD	Gross alpha	1	1		1		1	203	203	203	Ephemeral	15	pCi/L	Y
TA-18 Culvert	2000	UF	RAD	Tritium	1		1		1	1				Ephemeral	20000	pCi/L	N
Flood Water Over Bank Pajarito at G-1	2000	UF	RAD	Gross alpha	1	1		1		1	48.2	48.2	48.2	Ephemeral	15	pCi/L	Y
Flood Water Over Bank Pajarito at G-1	2000	UF	RAD	Tritium	1		1		1	1				Ephemeral	20000	pCi/L	N
Pajarito SR-4 Culvert	2000	UF	INORGANIC	Aluminum	1	1		1		1	252358.8	252359	252359	Ephemeral	750	ug/L	Y
Pajarito SR-4 Culvert	2000	UF	INORGANIC	Ammonia as Nitrogen	1	1		1		1	3400	3400	3400	Ephemeral	39.1	µg/L	Y
Pajarito SR-4 Culvert	2000	UF	INORGANIC	Arsenic	1	1		1		1	90.049	90.049	90.049	Ephemeral	9	µg/L	Y
Pajarito SR-4 Culvert	2000	UF	INORGANIC	Boron	1	1		1		1	480.018	480.018	480.018	Ephemeral	5000	µg/L	Y
Pajarito SR-4 Culvert	2000	UF	INORGANIC	Cadmium	1	1		1		1	12.908	12.908	12.908	Ephemeral	2.1	µg/L	Y
Pajarito SR-4 Culvert	2000	UF	INORGANIC	Chemical Oxygen Demand	1	1		1		1	519000	519000	519000	Ephemeral	120	µg/L	Y
Pajarito SR-4 Culvert	2000	UF	INORGANIC	Chromium	1	1		1		1	187.484	187.484	187.484	Ephemeral	580	µg/L	Y
Pajarito SR-4 Culvert	2000	UF	INORGANIC	Cobalt	1	1		1		1	143.905	143.905	143.905	Ephemeral	1000	µg/L	Y
Pajarito SR-4 Culvert	2000	UF	INORGANIC	Copper	1	1		1		1	446.974	446.974	446.974	Ephemeral	14	µg/L	Y
Pajarito SR-4 Culvert	2000	UF	INORGANIC	Cyanide [Total]	1	1		1		1	97	97	97	Ephemeral	0.0636	µg/L	Y
Pajarito SR-4 Culvert	2000	UF	INORGANIC	Cyanide, Amenable to Chlorination	1		1		1	1				Ephemeral	0.0052	µg/L	N
Pajarito SR-4 Culvert	2000	UF	INORGANIC	Lead	1	1		1		1	629.891	629.891	629.891	Ephemeral	81.7	µg/L	Y
Pajarito SR-4 Culvert	2000	UF	INORGANIC	Magnesium	1	1		1		1	73362.82	73362.8	73362.8	Ephemeral	0.0636	µg/L	Y
Pajarito SR-4 Culvert	2000	UF	INORGANIC	Mercury	1	1		1		1	0.38	0.38	0.38	Ephemeral	0.77	µg/L	Y

Location ID	Year	Field Prep	RFI Class	Analyte Name	Number of Analyses	Detected	Nondetect	Count Detect > Wsal	Count Nd > Wsal	Total Analyses > Wsal	Average	Min	Max	Stream Type	Wsal	Units	Ever Detected?
Pajarito SR-4 Culvert	2000	UF	INORGANIC	Nickel	1	1		1		1	245.789	245.789	245.789	Ephemeral	469	µg/L	Y
Pajarito SR-4 Culvert	2000	UF	INORGANIC	Nitrate-Nitrite as Nitrogen	1	1		1		1	670	670	670	Ephemeral	132	µg/L	Y
Pajarito SR-4 Culvert	2000	UF	INORGANIC	Selenium	1	1		1		1	48.317	48.317	48.317	Ephemeral	5	µg/L	Y
Pajarito SR-4 Culvert	2000	UF	INORGANIC	Silver	1	1		1		1	16.937	16.937	16.937	Ephemeral	3.8	µg/L	Y
Pajarito SR-4 Culvert	2000	UF	INORGANIC	Thallium	1	1		1		1	20.228	20.228	20.228	Ephemeral	6.3	µg/L	Y
Pajarito SR-4 Culvert	2000	UF	INORGANIC	Vanadium	1	1		1		1	385.018	385.018	385.018	Ephemeral	100	µg/L	Y
Pajarito SR-4 Culvert	2000	UF	INORGANIC	Zinc	1	1		1		1	1592.923	1592.92	1592.92	Ephemeral	120	µg/L	Y
Pajarito SR-4 Culvert	2000	UF	ORGANIC	Aroclor-1016	1		1		1	1				Ephemeral	0.00064	µg/L	N
Pajarito SR-4 Culvert	2000	UF	ORGANIC	Aroclor-1221	1		1		1	1				Ephemeral	0.00064	µg/L	N
Pajarito SR-4 Culvert	2000	UF	ORGANIC	Aroclor-1232	1		1		1	1				Ephemeral	0.00064	µg/L	N
Pajarito SR-4 Culvert	2000	UF	ORGANIC	Aroclor-1242	1		1		1	1				Ephemeral	0.00064	µg/L	N
Pajarito SR-4 Culvert	2000	UF	ORGANIC	Aroclor-1248	1		1		1	1				Ephemeral	0.00064	µg/L	N
Pajarito SR-4 Culvert	2000	UF	ORGANIC	Aroclor-1254	1		1		1	1				Ephemeral	0.00064	µg/L	N
Pajarito SR-4 Culvert	2000	UF	ORGANIC	Aroclor-1260	1		1		1	1				Ephemeral	0.00064	µg/L	N
Pajarito SR-4 Culvert	2000	UF	ORGANIC	Benzo[a]pyrene	1		1		1	1				Ephemeral	0.18	µg/L	N
Pajarito SR-4 Culvert	2000	UF	ORGANIC	Hexachlorobenzene	1		1		1	1				Ephemeral	0.0029	µg/L	N
Pajarito SR-4 Culvert	2000	UF	ORGANIC	Pentachlorophenol	1		1		1	1				Ephemeral	19	µg/L	N
Pajarito SR-4 Culvert	2000	UF	ORGANIC	RDX	1		1		1	1				Ephemeral	200	µg/L	N
Pajarito SR-4 Culvert	2000	UF	ORGANIC	Tetrachlorodibenzodioxin[2,3,7,8-]	1		1		1	1				Ephemeral	5.1E-08	µg/L	N
Pajarito SR-4 Culvert	2000	UF	ORGANIC	Trinitrotoluene[2,4,6-]	1		1		1	1				Ephemeral	20	µg/L	N
Pajarito SR-4 Culvert	2000	UF	RAD	Gross alpha	1	1		1		1	125.1	125.1	125.1	Ephemeral	15	pCi/L	Y
Pajarito SR-4 Culvert	2000	UF	RAD	Tritium	1		1		1	1				Ephemeral	20000	pCi/L	N
Twomile above SR-501	2000	UF	INORGANIC	Aluminum	1	1		1		1	82500	82500	82500	Ephemeral	750	µg/L	Y
Twomile above SR-501	2000	UF	INORGANIC	Ammonia as Nitrogen	1	1		1		1	1200	1200	1200	Ephemeral	39.1	µg/L	Y
Twomile above SR-501	2000	UF	INORGANIC	Antimony	1	1		1		1	0.385	0.385	0.385	Ephemeral	640	µg/L	Y
Twomile above SR-501	2000	UF	INORGANIC	Arsenic	1	1		1		1	23	23	23	Ephemeral	9	µg/L	Y
Twomile above SR-501	2000	UF	INORGANIC	Boron	1	1		1		1	90.5	90.5	90.5	Ephemeral	5000	µg/L	Y
Twomile above SR-501	2000	UF	INORGANIC	Cadmium	1	1		1		1	4.68	4.68	4.68	Ephemeral	2.1	µg/L	Y
Twomile above SR-501	2000	UF	INORGANIC	Chemical Oxygen Demand	1	1		1		1	392000	392000	392000	Ephemeral	120	µg/L	Y

Location ID	Year	Field Prep	RFI Class	Analyte Name	Number of Analyses	Detected	Nondetect	Count Detect > Wsal	Count Nd > Wsal	Total Analyses > Wsal	Average	Min	Max	Stream Type	Wsal	Units	Ever Detected?
Twomile above SR-501	2000	UF	INORGANIC	Chromium	1	1		1		1	35.2	35.2	35.2	Ephemeral	580	µg/L	Y
Twomile above SR-501	2000	UF	INORGANIC	Cobalt	1	1		1		1	53.3	53.3	53.3	Ephemeral	1000	µg/L	Y
Twomile above SR-501	2000	UF	INORGANIC	Copper	1	1		1		1	51.6	51.6	51.6	Ephemeral	14	µg/L	Y
Twomile above SR-501	2000	UF	INORGANIC	Cyanide [Total]	1	1		1		1	11.1	11.1	11.1	Ephemeral	0.0636	µg/L	Y
Twomile above SR-501	2000	UF	INORGANIC	Cyanide, Amenable to Chlorination	1		1		1	1				Ephemeral	0.0052	µg/L	N
Twomile above SR-501	2000	UF	INORGANIC	Lead	1	1		1		1	124	124	124	Ephemeral	81.7	µg/L	Y
Twomile above SR-501	2000	UF	INORGANIC	Magnesium	1	1		1		1	19400	19400	19400	Ephemeral	0.0636	µg/L	Y
Twomile above SR-501	2000	UF	INORGANIC	Mercury	1		1		1	1				Ephemeral	0.77	µg/L	N
Twomile above SR-501	2000	UF	INORGANIC	Nickel	1	1		1		1	50.2	50.2	50.2	Ephemeral	469	µg/L	Y
Twomile above SR-501	2000	UF	INORGANIC	Nitrate-Nitrite as Nitrogen	1	1		1		1	140	140	140	Ephemeral	132	µg/L	Y
Twomile above SR-501	2000	UF	INORGANIC	Selenium	1		1		1	1				Ephemeral	5	µg/L	N
Twomile above SR-501	2000	UF	INORGANIC	Silver	1		1		1	1				Ephemeral	3.8	µg/L	N
Twomile above SR-501	2000	UF	INORGANIC	Thallium	1	1		1		1	0.808	0.808	0.808	Ephemeral	6.3	µg/L	Y
Twomile above SR-501	2000	UF	INORGANIC	Vanadium	1	1		1		1	83.3	83.3	83.3	Ephemeral	100	µg/L	Y
Twomile above SR-501	2000	UF	INORGANIC	Zinc	1	1		1		1	538	538	538	Ephemeral	120	µg/L	Y
Twomile above SR-501	2000	UF	ORGANIC	Aroclor-1016	1		1		1	1				Ephemeral	0.00064	µg/L	N
Twomile above SR-501	2000	UF	ORGANIC	Aroclor-1221	1		1		1	1				Ephemeral	0.00064	µg/L	N
Twomile above SR-501	2000	UF	ORGANIC	Aroclor-1232	1		1		1	1				Ephemeral	0.00064	µg/L	N
Twomile above SR-501	2000	UF	ORGANIC	Aroclor-1242	1		1		1	1				Ephemeral	0.00064	µg/L	N
Twomile above SR-501	2000	UF	ORGANIC	Aroclor-1248	1		1		1	1				Ephemeral	0.00064	µg/L	N
Twomile above SR-501	2000	UF	ORGANIC	Aroclor-1254	1		1		1	1				Ephemeral	0.00064	µg/L	N
Twomile above SR-501	2000	UF	ORGANIC	Aroclor-1260	1		1		1	1				Ephemeral	0.00064	µg/L	N
Twomile above SR-501	2000	UF	ORGANIC	Benzo[a]pyrene	1		1		1	1				Ephemeral	0.18	µg/L	N
Twomile above SR-501	2000	UF	ORGANIC	Hexachlorobenzene	1		1		1	1				Ephemeral	0.0029	µg/L	N
Twomile above SR-501	2000	UF	ORGANIC	Pentachlorophenol	1		1		1	1				Ephemeral	19	µg/L	N
Twomile above SR-501	2000	UF	ORGANIC	Tetrachlorodibenzodioxin[2,3,7,8-]	1		1		1	1				Ephemeral	5.1E-08	µg/L	N
Twomile above SR-501	2000	UF	ORGANIC	Tetrachloroethene	1		1		1	1				Ephemeral	33	µg/L	N
Twomile above SR-501	2000	UF	RAD	Gross alpha	1	1		1		1	246	246	246	Ephemeral	15	pCi/L	Y
Twomile above SR-501	2000	UF	RAD	Radium-226	1	1		1		1	7.05	7.05	7.05	Ephemeral	30	pCi/L	Y

Location ID	Year	Field Prep	RFI Class	Analyte Name	Number of Analyses	Detected	Nondetect	Count Detect > Wsal	Count Nd > Wsal	Total Analyses > Wsal	Average	Min	Max	Stream Type	Wsal	Units	Ever Detected?
Twomile above SR-501	2000	UF	RAD	Radium-228	1		1		1	1				Ephemeral	30	pCi/L	N
Twomile above SR-501	2000	UF	RAD	Tritium	1		1		1	1				Ephemeral	20000	pCi/L	N
Pajarito Canyon	1997	F	INORGANIC	Cyanide [Total]	1		1		1	1				Ephemeral	0.0636	ug/L	N
Pajarito Canyon	1997	UF	INORGANIC	Aluminum	1	1		1		1	5046.2	5046.2	5046.2	Ephemeral	750	µg/L	Y
Pajarito Canyon	1997	UF	INORGANIC	Antimony	1		1		1	1				Ephemeral	640	µg/L	N
Pajarito Canyon	1997	UF	INORGANIC	Arsenic	1		1		1	1				Ephemeral	9	µg/L	N
Pajarito Canyon	1997	UF	INORGANIC	Boron	1		1		1	1				Ephemeral	5000	µg/L	N
Pajarito Canyon	1997	UF	INORGANIC	Cadmium	1		1		1	1				Ephemeral	2.1	µg/L	N
Pajarito Canyon	1997	UF	INORGANIC	Chromium	1		1		1	1				Ephemeral	580	µg/L	N
Pajarito Canyon	1997	UF	INORGANIC	Cobalt	1		1		1	1				Ephemeral	1000	µg/L	N
Pajarito Canyon	1997	UF	INORGANIC	Copper	1		1		1	1				Ephemeral	14	µg/L	N
Pajarito Canyon	1997	UF	INORGANIC	Cyanide [Total]	1		1		1	1				Ephemeral	0.0636	µg/L	N
Pajarito Canyon	1997	UF	INORGANIC	Lead	1		1		1	1				Ephemeral	81.7	µg/L	N
Pajarito Canyon	1997	UF	INORGANIC	Magnesium	1	1		1		1	2900	2900	2900	Ephemeral	0.0636	µg/L	Y
Pajarito Canyon	1997	UF	INORGANIC	Nickel	1		1		1	1				Ephemeral	469	µg/L	N
Pajarito Canyon	1997	UF	INORGANIC	Selenium	1		1		1	1				Ephemeral	5	µg/L	N
Pajarito Canyon	1997	UF	INORGANIC	Silver	1		1		1	1				Ephemeral	3.8	µg/L	N
Pajarito Canyon	1997	UF	INORGANIC	Thallium	1		1		1	1				Ephemeral	6.3	µg/L	N
Pajarito Canyon	1997	UF	INORGANIC	Vanadium	1		1		1	1				Ephemeral	100	µg/L	N
Pajarito Canyon	1997	UF	INORGANIC	Zinc	1		1		1	1				Ephemeral	120	ug/L	N
Pajarito Canyon	1997	UF	RAD	Gross alpha	1	1		1		1	2.1	2.1	2.1	Ephemeral	15	pCi/L	Y
Pajarito Canyon	1997	UF	RAD	Tritium	1	1		1		1	-93	-93	-93	Ephemeral	20000	pCi/L	Y

Appendix G

*Monitoring Well Reports
(on CD included with this document)*

Appendix H

*Core Moisture and Anion-Leachate and Tritium Data for
Pajarito Canyon Deep Core Holes*

H-1.0 INTRODUCTION

Core samples were collected at drill sites R-17, R-20, and R-32 in Pajarito Canyon (Figure 3.2-1). At R-17, the planned core depth of 91 m (300 ft) was attained; at R-20 and R-32 depth was limited as anticipated by difficulty in coring into Cerros del Rio lavas. Figure H-1.0-1 shows moisture and deionized-water leach anion-pore water data profiles for these three core holes, at a common scale and adjusted to elevation. Tritium data are also indicated in this figure, showing concentrations as detected and location of samples where tritium was not detected. The moisture and leachate data for each core hole are summarized below.

H-2.0 R-17

The R-17 site is approximately 460 m (1500 ft) downcanyon from the Pajarito Canyon Flood Retention Structure. Core was collected at R-17 using a 9.9-cm (3.9-in.) inside diameter (I.D.) HQ core barrel to a depth of 71 m (232.9 ft), where difficulty in advancing the core barrel and poor recovery prompted transition to a 5.1-cm (2-in.) outside diameter (O.D.) split spoon. Total core depth was 91.7 m (300.9 ft). The American Society for Testing and Materials (ASTM) gravimetric moisture profile (percent moisture/dry basis; Figure H-1) in R-17 core samples is relatively uniform ($20\% \pm 3\%$) throughout Tshirege unit Qbt 1g and the upper Otowi ash flows (Qbo). Pore-water concentrations of F, Cl, NO_3 , and SO_4 are relatively low but all show a general decrease in concentration with increasing depth. Tritium analyses were collected from core at R-17 to a depth of 91.4 m (300 ft) (Figure-H-1.0-1), but the results provided are so high (ranging from 539,370 to 1,380,117 pCi/L) that they are presently considered suspect. These results and the problems with them are discussed in more detail in Section 7.2.2.3.

H-3.0 R-20

Three initial coring attempts at the R-20 site using auger methods failed to reach a depth greater than 22.1 m (72.5 ft) but did provide five core samples from alluvium, the deepest at 19.93–19.99 m (65.4–65.6-ft) depth. Core from suballuvial units was collected at a later date, following drilling of the regional borehole to 416-m (1365-ft) depth. The suballuvial core samples were collected using a DR-24 drill rig and a 6.4-cm (2.5-in.) I.D. core barrel. Total core depth was 133 m (436 ft). The ASTM moisture profile for alluvium is somewhat variable at $14\% \pm 5\%$, with the highest moisture content an outlier (23%) at the base of alluvium. In core samples from Tshirege unit Qbt 1g and the Otowi ash flows (Qbo), moisture content is $17\% \pm 5\%$ (Figure H-1.0-1). The SO_4 concentration of the deepest alluvial sample is exceptionally high (1332 mg/L), with corresponding elevated pore-water concentrations of F, Cl, and NO_3 . In contrast, a high NO_3 value (58 mg/L) within Tshirege unit Qbt 1g is not associated with elevated concentrations of other solutes. Pore-water concentrations for these solutes are low through the Otowi ash flows but are elevated in the lower of two samples from the Guaje Pumice Bed. It should be noted however that the moisture content measured from the lower Guaje sample is exceptionally low (2% vs. 18% in the other Guaje sample), and the calculated pore-water concentrations based on adjustment to measured moisture may be artifacts of this anomalously low moisture. Figure H-1.0-1 also shows that the only detections of tritium from core leachate at R-20 are within the alluvium.

H-4.0 R-32

Core was collected at R-32 using a universal drill rig-1000 drill rig with a 6.4-cm (2.5-in.) I.D. core barrel. Caving problems were persistent to 20.1-m (66-ft) depth, attributed to substantial alluvial water encountered at 6.7-m (22-ft) depth. A second hole was located 3.0 m (10 ft) to the east and cased off to 18.0-m (59.1-ft) depth; deeper core samples were collected in this second hole with the deepest core collected from Cerros del Rio lava in a long core interval at 88.7–92.0-m (291–302-ft) depth. The ASTM gravimetric moisture contents of the two alluvial core samples (Figure H-1.0-1) are 12-14%; the six core samples from Tshirege unit Qbt 1g have highly variable moisture content ($19\% \pm 8\%$). Only one core sample was collected from the Cerro Toledo interval, and this core had exceptionally low moisture content (4%). Note that this is the only core sample of Cerro Toledo obtained from the three coreholes in Pajarito Canyon and thus representation for this unit is poor. At R-32, the two core samples from the Otowi Member provide only single values, one representing ash flow (12% moisture) and one from the Guaje Pumice Bed (34% moisture). Pore-water concentrations of Cl and SO₄ are relatively elevated in uppermost alluvial sample and in the Cerro Toledo, but the data from the Cerro Toledo may be artifacts of the exceptionally low moisture content in this sample (4%), leading to overestimation in calculated concentrations. A similar concern could affect the high Cl concentration shown for the Cerros del Rio sample where measured core moisture was only 3%. Figure H-1.0-1 shows that the only detection of tritium from core pore water at R-32 is within the alluvium.

H-5.0 DISCUSSION

Core pore-water anion and tritium data available from R-17, R-20, and R-32 indicate that most leachate concentrations decrease with depth, suggesting limited migration of groundwater in the subsurface at these locations. Some specific solute signatures point to contaminant effects. Based on the R-20 data, most prominently in the high nitrate concentrations in the upper alluvium and in Tshirege unit Qbt 1g at 19.8-m (65-ft) depth, there has been some downcanyon migration of sanitary waste contaminants from septic fields associated with Technical Area 18 (TA-18). Before 1992, most of the main building sewage from TA-18 was passed through sewer lines to the inactive and remediated lagoons 1.4 km (0.84 mi) downcanyon (near alluvial well 18-MW-18). These lagoons were located between R-20 and R-32. The absence of any significant nitrate in the core samples from R-32 (Figure H-1.0-1) indicates that either the lagoon system was not a significant source of sewage releases or nitrate did not infiltrate significantly at R-32. Although most of the main building sewage went to the lagoons, some of the central facilities and several outlier buildings at TA-18 had their own septic systems. Seven such septic systems with associated leach fields were active over various periods between 1944 and 1995 (LANL 1998, 059577). Several of these leach fields are close to the Pajarito or Threemile stream channels upcanyon from R-20; leach field communication with these streams is the likeliest source of nitrate observed in the upper vadose zone at R-20.

Sulfate concentrations in pore water follow a declining trend with depth at R-17 that likely represents infiltration of surface water with somewhat elevated sulfate. Sulfate concentrations in pore water within alluvium farther downcanyon at R-20 that are exceptionally high in the deepest alluvium imply either a sulfate discharge from the TA-18 area or a possible sulfate-bearing soil zone; correlation with a nitrate spike at this depth suggests TA-18 as the likely sulfate source. As discussed above, the rise in sulfate abundance shown within the lowermost Gauje Pumice Bed (Qbog) at R-20 and in the Cerro Toledo sediments (Qct) and Cerros del Rio lavas at R-32 are interpreted as artifacts of exceptionally low measured moisture contents in core samples that do not produce accurate pore-water concentrations for this analyte.

Halogens are generally of low abundance in R-17; the small Cl abundance, declining with depth, parallels the moisture content and likely represents infiltration of alluvial water with a small road salt contribution. Spikes in Cl abundance occur in the alluvium at R-20 and R-32; these high Cl abundances are likely caused by heavy use of road salt along this portion of Pajarito Canyon. As discussed above, the rise in Cl abundance shown within the lowermost Guaje Pumice Bed (Qbog) at R-20, and in the Cerro Toledo sediments (Qct) and Cerros del Rio lavas at R-32, are interpreted as artifacts of exceptionally low measured moisture contents that do not produce realistic recalculation of leached Cl concentration in pore water.

Tritium data are shown in Figure H-1.0-1 for core from R-17, R-20, and R-32. The only measurable tritium in core from R-20 and R-32 is within alluvium; all deeper core samples at these two localities show no detectable tritium. This calls in question the exceptionally high tritium detections reported in analyses of all core samples at R-17, to 91.4-m (300-ft) depth. These results are currently being reevaluated by the analytical laboratory for verification. Further discussion of the R-17 core tritium data is provided in Section 7.2.2.3.

H-6.0 REFERENCE

The following list includes all documents cited in this appendix. Parenthetical information following each reference provides the author(s), publication date, and ER ID number. This information is also included in text citations. ER ID numbers are assigned by the Environmental Programs Directorate's Records Processing Facility (RPF) and are used to locate the document at the RPF and, where applicable, in the master reference set.

Copies of the master reference set are maintained at the New Mexico Environment Department Hazardous Waste Bureau; the U.S. Department of Energy—Los Alamos Site Office; the U.S. Environmental Protection Agency, Region 6; and the Directorate. The set was developed to ensure that the administrative authority has all material needed to review this document, and it is updated with every document submitted to the administrative authority. Documents previously submitted to the administrative authority are not included.

LANL (Los Alamos National Laboratory), September 1998. "Work Plan for Pajarito Canyon," Los Alamos National Laboratory document LA-UR-98-2550, Los Alamos, New Mexico. (LANL 1998, 059577)

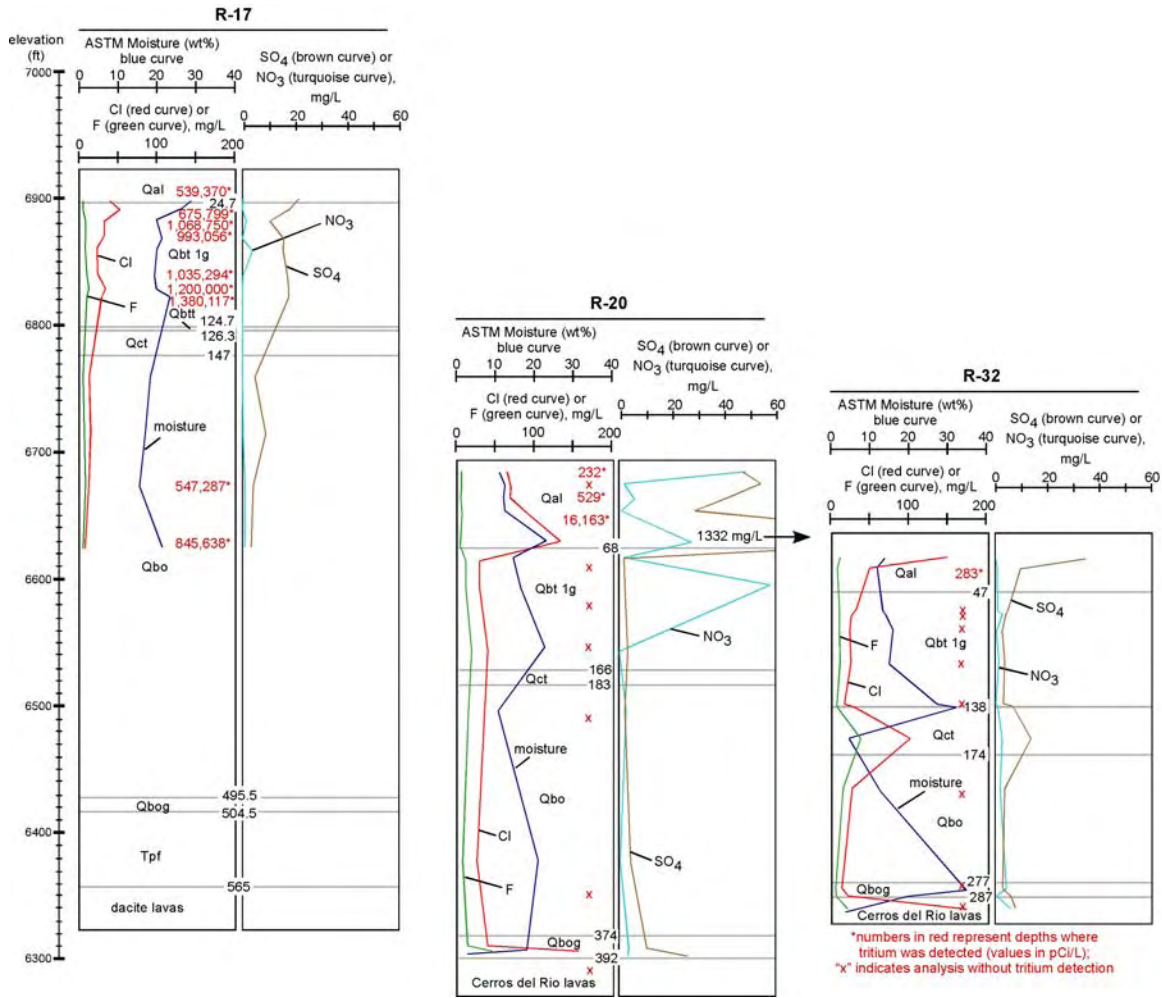

Figure H-1.0-1 Core moisture and deionized-water anion-leachate concentrations for R-17, R-20 and R-32. All horizontal and vertical scales are constant and core profiles are adjusted to a fixed elevation. Depths to stratigraphic contacts are in feet; stratigraphic symbols are alluvium (Qal), glassy nonwelded lower ash flows of the Tshirege Member, Bandelier Tuff (Qbt 1g), Tsankawi Pumice Bed (Qbtt), Cerro Toledo Formation (Qct), ash flows of the Otowi Member, Bandelier Tuff (Qbo), Guaje Pumice Bed (Qbog), and Puye Formation (Tpf).

Appendix I

*Analysis of Transient Water Levels Observed at Regional
Aquifer Monitoring Wells near Pajarito Canyon*

I-1.0 INTRODUCTION

Analysis of transient water levels observed in the regional aquifer at the monitoring wells near Pajarito Canyon provides information about the magnitude of pumping drawdowns caused by the water-supply wells in the vicinity. The analysis also provides information about the hydrogeologic properties of the regional aquifer, the potential effect of local infiltration recharging the aquifer beneath Pajarito Canyon, and water-supply pumping on groundwater-flow directions. The complex hydrogeology evident at the Los Alamos National Laboratory site and the relatively small magnitude of the observed water-level transients in the shallow portion of the regional aquifer present particular challenges for this analysis. This appendix discusses a hydraulic survey of transients observed at monitoring wells R-18, R-17, R-19, R-20, R-21, R-32, R-22, and R-23 using an analytical flow model.

I-2.0 WATER-LEVEL DATA

The observation wells in and near Pajarito Canyon monitor water-level elevations in the shallow and the deep portions of the regional aquifer. The shallow portion of the aquifer is predominantly under phreatic (unconfined) conditions. Water-supply wells in the vicinity pump from the deeper portion of the aquifer, which is predominantly under confined conditions (e.g., PM-2, PM-4, and PM-5). The drawdown at the supply wells varies from 10 to 25 m. The gradients and flow directions in the phreatic zone exhibit a predominant influence from ambient flow, with a less pronounced influence from water-supply pumping. The ambient flow is controlled by areas of recharge (flanks of the Sierra de los Valles and along segments of some of the canyons on the plateau) and discharge to the east (the Rio Grande and the White Rock Canyon Springs).

Figure I-2.0-1 presents groundwater levels (as absolute water-level elevations above sea level) for the observation wells near Pajarito Canyon. The wells are ordered based on their location along the canyon from west to east. The figure presents the complete data record since 2003. Note that the water levels at R-20 were measured until summer 2006; since then the well was rehabilitated. There is a short data record of water levels since the rehabilitation. The water levels of R-18, R-17, R-21, and R-23 are corrected to remove barometric pressure fluctuations, assuming 100% barometric efficiency. The water levels of some of the wells (R-18, R-17 screen 1, R-21, and R-23) show sharp water-level declines when water-quality samples are collected (represented as almost vertical lines in Figure I-2.0-1). The magnitude of drawdown depends on the aquifer and well properties as well as the pumping rate during sampling. The total fluctuation in groundwater levels over the period of record is relatively small (excluding the sampling events). The largest water-level fluctuations are observed in deep screens: R-20 screen 3 and R-32 screens 2 and 3. Figure I-2.0-1 also presents the daily pumping (production) volumes at the water-supply wells on the Pajarito Plateau. Note that the pumping at all the wells, except PM-4, is cycled on a daily basis. PM-4 is pumped continuously when in operation during the summer season.

A visual comparison between the fluctuations in the groundwater levels and in the pumping volumes does not demonstrate clear correlations, except between data for R-19 screens 4 to 7, R-20 screens 2 and 3, R-32 screens 2 and 3, and PM-4. In February 2005, a pumping test was conducted at PM-4 and the water levels at these screens show a distinct response to the PM-4 pumping. However, during the test, water-level data were not collected at the other monitoring wells presented in Figure I-2.0-1. The visual comparison between the fluctuations in the groundwater levels also suggests correlation between data observed at (1) R-19 (screens 4 to 7), R-20 (screen 3), and R-32 (screens 2 and 3) (due to pumping influences); (2) R-18 and R-23 (a general trend of water-level decline), (3) R-17 (screen 2) and R-21 (low water levels in summer 2007). It is important to note that the deep screens of R-22 do not show any response to pumping. This is somewhat surprising considering that the elevations of R-22 screens

(elevations range from 5778 to 5198 ft) are in the range of the PM-2 louvers (elevation from 5711 to 4445 ft) (see also Figure 7.2-1).

Influences that may be present in the water-level records include (1) pumping effects, (2) measurement errors, (3) barometric effects (the total effect of barometric pressure fluctuations may not have been completely removed by the correction calculations), (4) variability in the ambient flux, (5) variability in local recharge beneath Pajarito Canyon or other canyons (identification of such transients typically require much longer observation periods than the existing almost 5-yr water-level record), and (6) subsidence (pore-elastic effects) from water-supply pumping.

The following discussion analyzes transient water levels by estimating pumping drawdown using simple analytical techniques that account for pumping influences. This approach allows fingerprinting of pumping influences at observation well locations, given contrasting pumping records, estimation of potential drawdown effects associated with individual pumping wells, and estimation of effective hydraulic properties of the aquifer between pumping and observation wells. While the use of a simple analytical model does not allow the accurate estimation of the spatial properties of aquifer heterogeneity, it can provide information about the aquifer properties, for example, nonuniform aquifer properties or aquifer anisotropy.

I-3.0 ANALYTICAL ESTIMATION OF POTENTIAL PUMPING EFFECTS

Pumping drawdown effects have been simulated using the Theis solution (Freeze and Cherry 1979, 088742, p. 317) defined as

$$s = \frac{Q}{4\pi T} W(u) = \frac{Q}{4\pi T} W\left(\frac{r^2 S}{4Tt}\right), \quad \text{Equation 1}$$

where s is the transient drawdown (L); Q is the discharge from the well (L^3T^{-1}); T is the transmissivity (L^2T^{-1}); $W(u)$ is the well function where $u = r^2 S/4Tt$, where r is the distance to the pumping well (L); S is the specific storage coefficient; and t is time since pumping commenced (T). The Theis solution is intended for homogeneous formations, precluding its ability to characterize spatial variation of hydraulic properties. Nevertheless, the equation can provide estimates for the pumping effects in heterogeneous formations if the effective properties of the aquifer are known.

The principle of superposition is used for the analysis to represent transient effects in pumping rates and to combine drawdown contributions from multiple water-supply wells in order to predict observed drawdown at a given monitoring well. In this way, the predicted drawdown at a monitoring well is a sum of drawdowns created by each production well during each pumping period:

$$s = \sum_{i=1}^N \sum_{j=1}^{M_i} \frac{Q_{ij} - Q_{ij-1}}{4\pi T_i} W\left(\frac{r_i^2 S_i}{4T_i(t - t_{Qij})}\right), \quad \text{Equation 2}$$

where N is the number of pumping wells, M_i is the number of pumping periods (i.e., number of pumping rate changes), Q_{ij} is the pumping rate of well i during pumping period j , and t_{Qij} is the time when the pumping rate changed at well i during pumping period j . In these analyses, seven pumping wells are considered, and the maximum number of pumping rate changes (M_i) is 2035 (for O-4). The principle of superposition allows for different effective hydraulic properties between different water supply/observation well pairs (T_i , S_i). In this way, it is possible to estimate to what extent the heterogeneity affects the observed drawdowns in the monitoring wells. Furthermore, discrepancies between the simulated and

observed pressures may suggest additional transients or heterogeneities that are currently not included in this model (e.g., transients in the ambient fluxes).

Inverse modeling is employed to identify effective hydraulic properties (transmissivity T and specific storage S), resulting in model predictions that are consistent with observed water-level elevations (calibration targets). The daily variations in the water-supply production record, which include the daily pumping and recovery periods, are explicitly represented in the model.

This inverse analysis is similar to the analysis of pumping tests. However, in this case, the pumping test includes multiple pumping wells that have transient pumping records. The benefits of this approach are twofold. (1) There is no need to perform specially designed field tests (which should include a prolonged cessation of pumping at all the production wells before the test, although this may not be feasible). (2) The effects of measurement errors may be mitigated given long water-level and pumping records.

I-4.0 RESULTS AND DISCUSSION

Figure I-4.0-1 presents results from inversions where a model is calibrated (as closely as possible) to simulate the water-level fluctuations observed at a particular monitoring location based on the production rate changes at the production wells. This analysis determines the extent to which water-level fluctuations at a particular (single) monitoring location can be characterized by drawdown caused by the pumping at the production wells. The drawdowns at R-19 (screens 4 to 7), R-20 (all screens), R-21 and R-32 (screens 2 and 3) are given in Figure I-4.0-1, and the model-predicted drawdown matches the data quite well. The model predicts that drawdown at these locations is caused by PM-2 and PM-4 pumping; no other pumping wells affect their drawdowns. Table I-4.0-1 provides information about pumping responses at all monitoring locations considered in this study. The water levels of the top regional-aquifer screens of R-19 (screen 3), R-17 (screen 1) and R-32 (screen 1) do not seem to be affected by the water-supply pumping. However, the water levels of the deeper screen of R-19 (screens 4 to 7), R-17 (screen 2) and R-32 (screens 2 and 3) are affected by the water-supply pumping. A preliminary analysis of the R-17 data suggests that PM-4 and potentially PM-2, but not PM-5, impact the R-17 screen 2 water levels. A longer water-level record will help to resolve this uncertainty. The modeling analysis confirms that the water levels at all the R-22 screens are not influenced by the PM-2 pumping. In addition, R-18 and R-23 show no apparent response to production-well pumping.

For each inversion model, the effective properties of the aquifer between the observation and pumping wells (PM-2 and PM-4) are estimated (Table I-4.0-1). The transmissivity estimates and specific storage estimates for R-20 screen 3 are similar to the previous estimates obtained through pumping tests at PM-2 and PM-4 (Table I-4.0-2) (2005, 090073; McLin 2006, 092218; McLin 2006, 093670).

I-5.0 CONCLUSIONS

A simple analytical model was used to extract groundwater information from production and water-level records about the properties of the regional aquifer beneath the Pajarito Canyon area. The inverse analysis of pressure responses from pumping suggests that there may be large-scale hydrogeologic structures (e.g., faults or troughs) with properties that are different from the rest of the aquifer. For example, the lack of apparent pressure response at R-22 to PM-2 pumping may suggest the existence of a hydraulic barrier between the wells. Further analyses may address these issues.

It is important to note that during the PM-2 and PM-4 pumping tests (McLin 2005, 090073, p. 7), aquifer properties were estimated using only R-20 screen 3 water-level data. In those studies, the water-level data from R-20 (screens 1 and 2), R-19, R-21, and R-32 were not explicitly analyzed to estimate the aquifer properties. However, the modeling and analysis presented here demonstrate that it is feasible to

analyze these data. This is because of the long water-level and pumping records that help substantially to constrain the model. The aquifer properties of R-20 screen 3 estimated by McLin (2005, 090073; 2006, 092218) are consistent with the estimates provided here. In this way, the presented analyses are consistent with, and improve on, existing work.

I-6.0 REFERENCES

The following list includes all documents cited in this appendix. Parenthetical information following each reference provides the author(s), publication date, and ER ID number. This information is also included in text citations. ER ID numbers are assigned by the Environmental Programs Directorate's Records Processing Facility (RPF) and are used to locate the document at the RPF and, where applicable, in the master reference set.

Copies of the master reference set are maintained at the New Mexico Environment Department Hazardous Waste Bureau; the U.S. Department of Energy–Los Alamos Site Office; the U.S. Environmental Protection Agency, Region 6; and the Directorate. The set was developed to ensure that the administrative authority has all material needed to review this document, and it is updated with every document submitted to the administrative authority. Documents previously submitted to the administrative authority are not included.

Freeze, R.A., and J.A. Cherry, January 1979. *Groundwater*, Prentice-Hall, Inc., Englewood Cliffs, New Jersey. (Freeze and Cherry 1979, 088742)

McLin, S., July 2005. "Analyses of the PM-2 Aquifer Test Using Multiple Observation Wells," Los Alamos National Laboratory report LA-14225-MS, Los Alamos, New Mexico. (McLin 2005, 090073)

McLin, S., January 2006. "Analyses of the PM-4 Aquifer Test Using Multiple Observation Wells," Los Alamos National Laboratory report LA-14252-MS, Los Alamos, New Mexico. (McLin 2006, 092218)

McLin, S.G., May 2006. "A Catalog of Historical Aquifer Tests on Pajarito Plateau," Los Alamos National Laboratory document LA-UR-06-3789, Los Alamos, New Mexico. (McLin 2006, 093670)

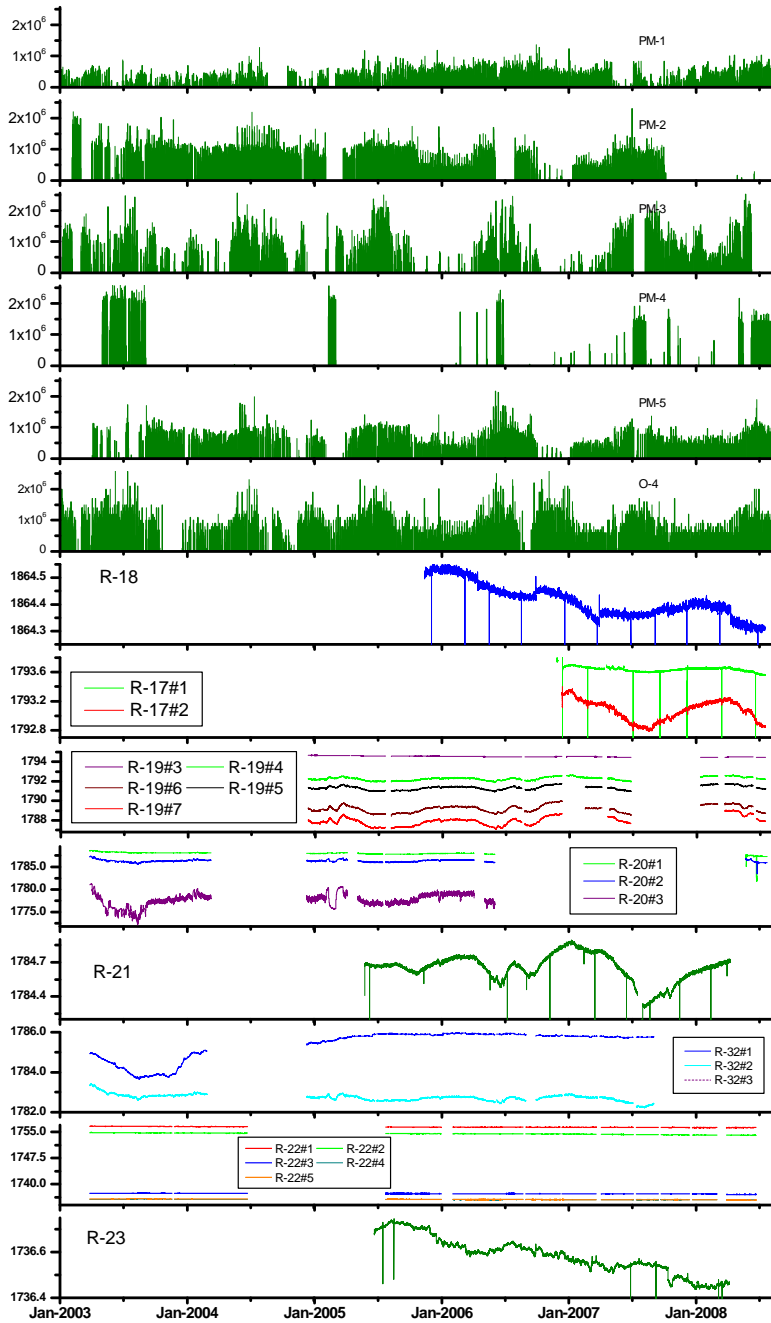

Figure I-2.0-1 Supply-well daily pumping volumes [gal.] for production wells and water-level elevations [m] at observation wells near Pajarito Canyon

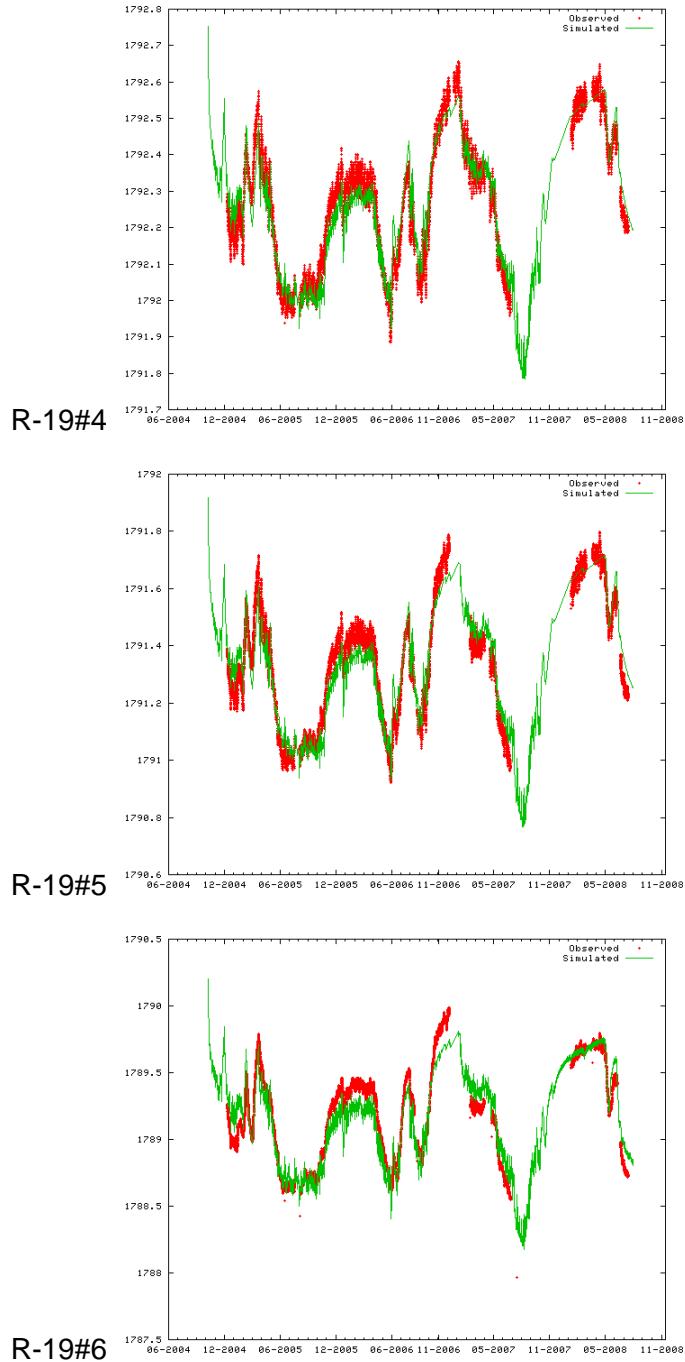
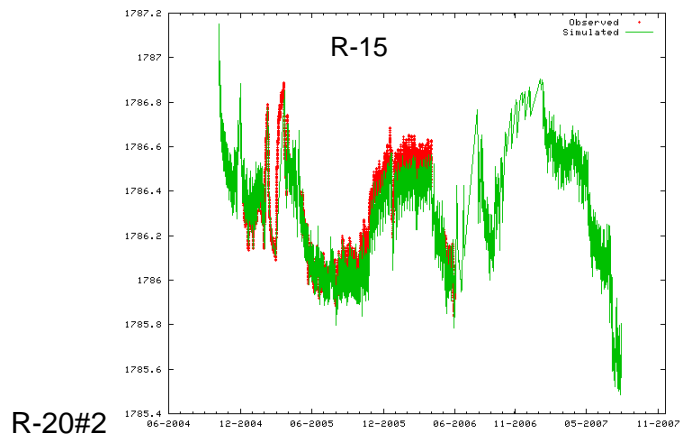
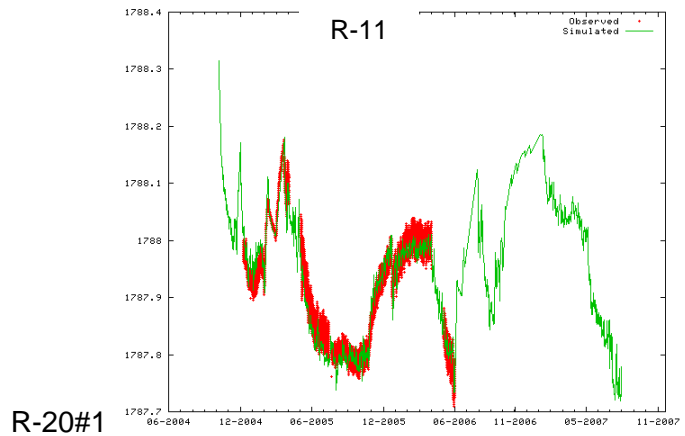
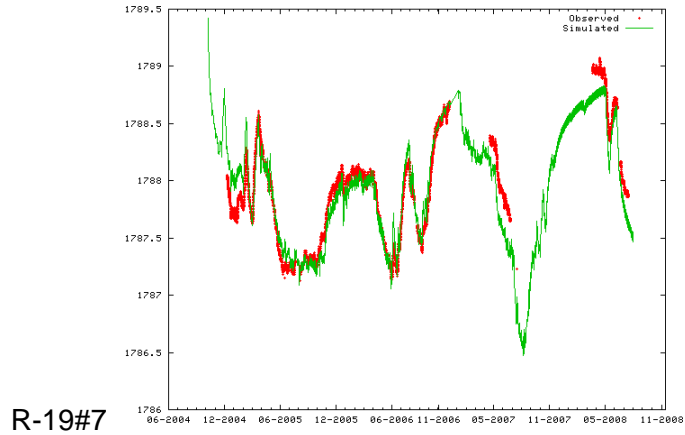

Figure I-4.0-1 Observed (red dots) and model-predicted (green line) water-level elevations [m] at individual monitoring wells. Each plot presents the results from a separate model inversion in response to water-supply pumping at PM-2 and PM-4 (the other production wells on the Pajarito Plateau do not appear to influence the observed water-levels at these monitoring wells). Note differences in the y-axis scales on each plot.



R-28

Figure I-4.0-1 (continued)

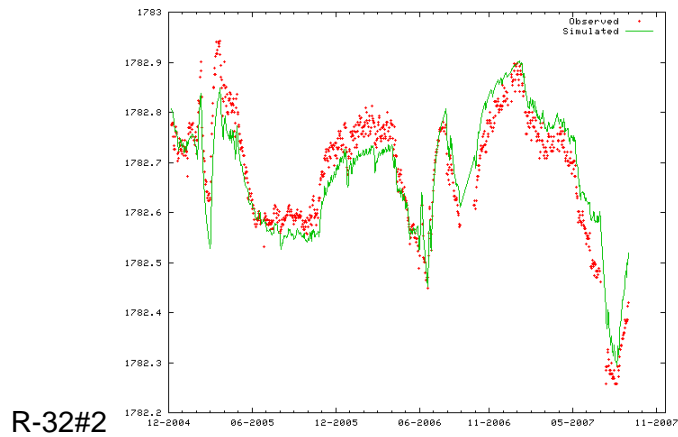
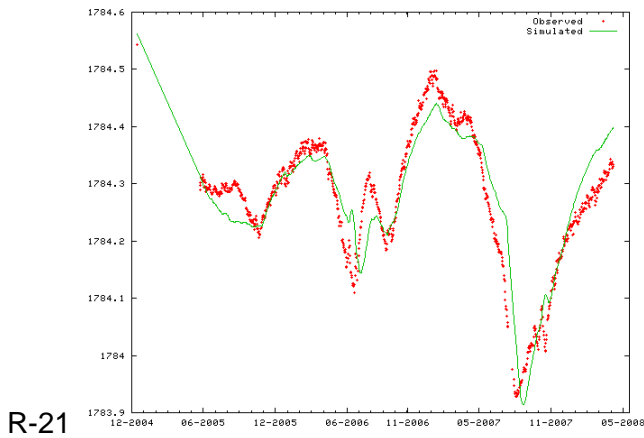
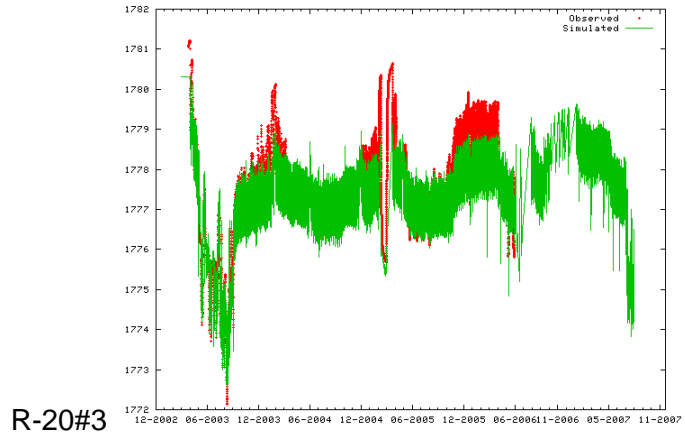

Figure I-4.0-1 (continued)

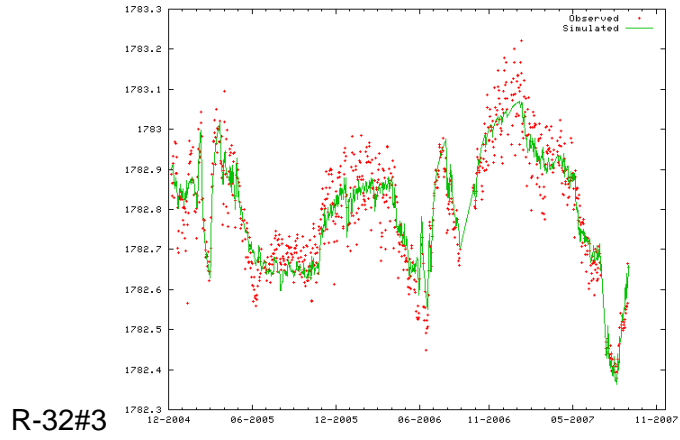

Figure I-4.0-1 (continued)

Table I-4.0-1
Estimates of Effective Aquifer Hydraulic Properties Based on Model Calibration

Well Screen	PM-2		PM-4		Comment
	T [m ² /d]	S [-]	T [m ² /d]	S [-]	
R-18	-*	-	-	-	No apparent pumping response to any production well
R-17#1	-	-	-	-	No apparent pumping response to any production well
R-17#2	-	-	-	-	Potential pumping responses to PM-2 and PM-4 but not PM-5; more data are needed
R-19#3	-	-	-	-	No apparent pumping response to any production well
R-19#4	2.6E+03	8.9E-04	2.9E+03	5.5E-03	Responses to PM-2 and PM-4; response to PM-5 pumping is small; more data are needed
R-19#5	2.1E+03	7.8E-04	2.6E+03	4.1E-03	Responses to PM-2 and PM-4; response to PM-5 pumping is small; more data are needed
R-19#6	1.3E+03	4.7E-04	1.4E+03	1.7E-03	Responses to PM-2 and PM-4; response to PM-5 pumping is small; more data are needed
R-19#7	7.6E+02	6.3E-04	8.7E+02	1.6E-03	Responses to PM-2 and PM-4; response to PM-5 pumping is small; more data are needed
R-20#1	4.2E+03	3.9E-02	8.5E+03	1.5E-02	Responses to PM-2 and PM-4 only
R-20#2	1.9E+03	6.2E-03	3.2E+03	8.9E-04	Responses to PM-2 and PM-4 only
R-20#3	4.5E+02	9.1E-04	7.9E+02	2.2E-05	Responses to PM-2 and PM-4 only
R-21	1.7E+03	2.9E-02	1.1E+03	9.3E-03	Responses to PM-2 and PM-4 only
R-32#1	-	-	-	-	No apparent pumping response to any production well
R-32#2	3.1E+03	6.0E-03	3.8E+03	2.5E-03	Responses to PM-2 and PM-4 only
R-32#3	3.1E+03	2.9E-03	4.0E+03	1.5E-03	Responses to PM-2 and PM-4 only
R-22#1	-	-	-	-	No apparent pumping response to any production well
R-22#2	-	-	-	-	No apparent pumping response to any production well
R-22#3	-	-	-	-	No apparent pumping response to any production well
R-22#4	-	-	-	-	No apparent pumping response to any production well
R-22#5	-	-	-	-	No apparent pumping response to any production well
R-23	-	-	-	-	No apparent pumping response to any production well

*— = Not estimated during calibration.

Table I-4.0-2
Estimates of Effective Aquifer Hydraulic Properties at
R-20 Screen 3 Based on Pumping Test Data

Parameter	PM-2	PM-4
Transmissivity [ft ² /d]	4312	2769
Transmissivity [m ² /d]	4.0E+02	2.6E+02
Storage [-]*	1.8E-03	1.5E-04

Sources: McLin (2005, 090073, p. 7) and McLin (2006, 092218).

*— = Dimensionless parameter.

Appendix J

Summary of the Spinner Test Conducted at PM-2

J-1.0 INTRODUCTION

Pajarito Mesa water-supply well 2 (PM-2) was constructed in 1965. The ground surface elevation at the well is 6715 ft, and the well extends to a total depth of 2300 ft below ground surface (bgs). It is screened from 1004 to 2280 ft bgs with a 14-in. × 0.040-in. louvered screen (McLin 2005, 090073). The top of the regional aquifer is expected to be about 845 ft bgs, based on an analysis of the elevation of the regional water table (equivalent elevation of ~5870 ft) (LANL 2007, 095364). The static (nonpumping) water level at PM-2 is about 5840 ft (~875 ft bgs). Because of observed hydraulic separation of the shallow and the deep sections of the regional aquifer (Vesselinov 2004, 090040), the elevation of the regional water table and the static nonpumping water level at PM-2 are not expected to be the same. For example, the water-level elevation at the top regional screen (1) of R-20 is about 5866 ft (Allen and Koch 2007, 095268). R-20 is the closest monitoring well to PM-2, located about 500 m due east.

During pumping, the water level at PM-2 declines to about 5760 ft (~955 ft bgs); the resultant pumping drawdown is about 80 ft (Koch and Rogers 2003, 088425). An unknown fraction of the drawdown is a head loss (based on the well parameters, the head loss might be on the order of 10 ft or more) (Freeze and Cherry 1979, 088742). Because of deteriorating hydraulic conditions, the pumping rate has progressively declined from about 1430 gpm in 1966 to about 1030 gpm in 2008, which indicates a progressive increase of the head losses during pumping. The well began pumping coarse sand and fine gravel in 2007. The material is believed to be gravel pack from around the well screen and casing (METRIC Corporation 2008, 102728). The well is equipped with a turbine pump with an inlet at 1011 ft bgs, which is about 7 ft below the top of the screen. It was speculated that the screen openings near the inlet (in the 1011-ft interval) may have eroded by water falling back down the column pipe when the pump is turned off. The well is also equipped with two-gage (access) lines with a diameter of 2 in. that enter the casing at a depth of about 995 ft.

To better characterize the hydrogeological properties of the well and identify the origin of the sediments pumped by the well, Los Alamos County in collaboration with Los Alamos National Laboratory (the Laboratory) performed testing of PM-2 in June 2008. The test included video, temperature, and spinner logging. The work was performed by pulling the pump, and the casing screen was cleaned with a wire brush.

J-2.0 RESULTS AND DISCUSSION

Video logs were conducted before and after the wire brushing procedure and during well pumping at rate of 1041 gpm. The videos do not reveal any apparent enlargement of the screen openings at the 1011-ft interval or at any other level (METRIC Corporation 2008, 102728). Additional analysis of the video logs suggests that the sand pumped by the well is probably entering the casing along one of the gage lines (METRIC Corporation 2008, 102728). One of the gage lines is not usable because a pressure transducer is stuck in it. The other gage line is used to collect water levels.

Spinner and temperature logs of PM-2 were conducted by Pacific Surveys in June 2008. Collected data are presented in Figures J-2.0-1, J-2.0-2, and J-2.0-3, which are the original plates produced by Pacific Survey. Figure J-2.0-4 is also produced by Pacific Surveys.

The collected data are also presented in a concise form in Figure J-2.0-5. Figure J-2.0-5 also includes (1) the hydrostratigraphy along the well based on a current update of the three-dimensional geological model of the Laboratory site and (2) the natural gamma log obtained in 1965 (Cooper et al. 1965, 008582).

The gamma log responds principally to uranium, thorium, and potassium concentrations in the subsurface lithologies, and it is useful for making cross-hole comparisons for identifying major hydrostratigraphic units. For example, the gamma log reveals the location of Miocene basalts in Figure J-2.0-5(a), based on their characteristic low gamma activities. (This identification is supported by cuttings obtained during drilling at PM-2 and by comparative gamma-log analysis of other wells in the vicinity.) Variations in gamma-log response for the Chamita Formation probably reflects the stratified nature of the sands and gravels (Cooper et al. 1965, 008582) that make up these riverine deposits in Figure J-2.0-5(a).

The spinner testing was conducted during well pumping at a rate of 1029 gpm; this pumping rate is representative of the pumping rate during water-supply production. The spinner test is used to approximate the locations of sections of the screened interval that produce water during pumping. The vertical distribution of groundwater production is estimated based on the vertical distribution of water velocity in the casing during pumping. The water velocity in the well is measured using a spinner tool. In well sections where the water is constant, there is little or no water production. In well sections where the water velocity increases substantially, water is produced approximately in proportion to spinner response. During the test, the spinner tool was run three times from the top to the bottom of the casing using three different velocities; the tool velocity (in feet per minute; [fpm]) is plotted in Figure J-2.0-5(c). A constant tool velocity is preferred because the water velocity is estimated relative to the tool velocity. The first run (Run 1, with an average velocity of about 30 fpm) failed at about 1850 ft bgs, as depicted in Figure J-2.0-5(b), when the spinner tool stopped spinning. However, the tool velocity was relatively uniform before the stoppage, as shown in Figure J-2.0-5(c). The other runs were successful but the tool velocity was less uniform. Typically, the higher the tool velocity, the better the resolution of the spinner log. The information from the three runs is jointly interpreted, and the result is presented in Figure J-2.0-5(b) (shown as a black line). The interpretative line characterizes the major changes in the slope (gradient) of the observed water velocity profiles; the line represents only the relative changes in the water velocity rather than the actual magnitude of water velocity.

Figure J-2.0-5(e) presents the estimated vertical distribution of the production from the aquifer based on the interpreted water velocity. It should be noted that the production distribution depends on the pumping rate. Higher or lower pumping rates will change the production distribution in a nonlinear fashion. Based on analysis of the spinner test, it appears that most production occurs in the upper section of the aquifer from about 1000 to 1820 ft bgs (or from about 160 to 975 ft below the regional water table). The Puye Formation and upper half of the Chamita Formation riverine deposits are the most productive water-bearing units. Miocene pumiceous beds and Miocene basalts appear to be nonproductive.

Variations in spinner velocities suggest that the Chamita Formation is hydraulically stratified, consistent with the lithological stratification inferred from the gamma log. Here this unit is divided into four subunits with different hydrogeologic properties based on the spinner test (A, B, C, and D from top to bottom). The top subunit (A) is highly productive and very permeable; it is marked by a sharp change in the water velocity below the Miocene nonproductive pumiceous beds, as seen in Figure J-2.0-5(b). This subunit appears to correlate to riverine gravels that were originally assigned to the Pliocene Totavi Lentil by Cooper et al. (1965, 008582). These riverine deposits

are now known to be older than the Totavi Lentil (Broxton and Vaniman 2005, 090038), but their lithological characteristics are generally similar. Subunit B is a sandy unit with some interbedded gravels (Cooper et al. 1965, 008582) and appears to be less permeable than subunit A. There might be a second interval of relative coarse sediments within subunit C, followed by slightly less permeable subunit D. The lower section of Chamita Formation below the Miocene basalts also produces groundwater, albeit at very low rate (2%). Because it is deeper (i.e., farther from the pump), it is not as stressed as the upper section of Chamita Formation. As a result, there is not much information about the vertical heterogeneity of the lower section of Chamita Formation. Low production from the lower section of Chamita Formation does not necessarily indicate that it has low permeability.

The analysis of the spinner data is summarized in Table J-2.0-1. The reported production rates are based on the pumping rate during the spinner tests, 1029 ppm. The table also lists the estimated production from the individual hydrostratigraphic units divided by their thickness; these estimates are proportional to the transmissivity (permeability) of the respective aquifer units. The table demonstrates that subunit A of Chamita Formation is the most permeable unit tapped by PM-2; it is about an order of magnitude more permeable than the Puye Formation and the other subunits of Chamita Formation.

It is interesting to note that the poorly transmissive Miocene pumiceous beds at PM-2 appear to be more transmissive where penetrated by wells to the north and to the west (e.g., at R-11 and R-28). X-ray diffraction analyses of hand-picked pumice separates from this interval at R-20, which is located next to PM-2, had about 13%–15% smectite, which is a fairly high clay mineral content for this interval (e.g., 0%–4.6% at R-7, Table 10.0-2, in Stone et al. 2002, 072717). Perhaps the thinner southern and eastern exposures of Miocene pumiceous beds are generally finer, more clay-rich, and very different in hydrogeologic properties relative to more transmissive pumiceous strata to the north and west.

Static and dynamic temperature logs are presented in Figure J-2.0-5(d). The static test was conducted when the pump was not being operated. The dynamic test was conducted during pumping at a rate of 1029 gpm. The logs show a strong increase of temperature below the Miocene basalts that may indicate inactive groundwater flow in the deep section of the well screen. Similar high temperatures in deep sections of the regional aquifer are observed at other water-supply wells (e.g., David Schafer & Associates 2006, 094699; Kleinfelder 2006, 092487). Normally, in a case of inactive groundwater flow, the temperature gradient linearly increases with depth, as shown in Figure J-2.0-5(d). However, the static log is not expected to represent ambient conditions because PM-2 was actively used for water supply before the testing took place (the last production was October 5, 2007, 8 mo before testing). Typically, active groundwater flow (ambient or caused by pumping) will decrease subsurface temperatures below the expected linear temperature gradient. In this case, pumping-influenced groundwater flow (as indicated by the spinner data) or ambient groundwater flow through the upper section of the aquifer effectively lowers the temperature to a relatively uniform value of about 75°F, as shown in Figure J-2.0-5(d). The temperature rapidly increases below the zone of active groundwater flow. The dynamic temperature log indicates that the temperature of the groundwater in the well generally increases during pumping. The most pronounced difference between the static and dynamic temperature logs is observed below the Miocene basalts, suggesting that some warmer groundwater is pumped from the deeper (and warmer) section of the aquifer. A longer pumping period is expected to further increase the temperature of water in the well. Additional analyses may be needed to address the effects of water-supply pumping on the vertical temperature gradients in the subsurface.

J-3.0 CONCLUSIONS

In summary, the water-supply pumping of PM-2 predominantly stresses the shallow section of the regional aquifer. Water is mostly produced from about 1000 to 1820 ft bgs (or from about 160 to 975 ft below the top of the regional aquifer, i.e., the regional water table). Most of the produced water originates from the upper Chamita Formation riverine deposits (~70%; below the Miocene pumiceous beds and above the Miocene basalt). In the uppermost section, the Puye Formation provides about 30% of the pumped water.

J-4.0 REFERENCES

The following list includes all documents cited in this appendix. Parenthetical information following each reference provides the author(s), publication date, and ER ID number. This information is also included in text citations. ER ID numbers are assigned by the Environmental Programs Directorate's Records Processing Facility (RPF) and are used to locate the document at the RPF and, where applicable, in the master reference set.

Copies of the master reference set are maintained at the New Mexico Environment Department Hazardous Waste Bureau; the U.S. Department of Energy–Los Alamos Site Office; the U.S. Environmental Protection Agency, Region 6; and the Directorate. The set was developed to ensure that the administrative authority has all material needed to review this document, and it is updated with every document submitted to the administrative authority. Documents previously submitted to the administrative authority are not included.

Allen, S.P., and R.J. Koch, March 2007. "Groundwater Level Status Report for Fiscal Year 2006, Los Alamos National Laboratory," Los Alamos National Laboratory report LA-14331-PR, Los Alamos, New Mexico. (Allen and Koch 2007, 095268)

Broxton, D.E., and D.T. Vaniman, August 2005. "Geologic Framework of a Groundwater System on the Margin of a Rift Basin, Pajarito Plateau, North-Central New Mexico," *Vadose Zone Journal*, Vol. 4, No. 3, pp. 522–550. (Broxton and Vaniman 2005, 090038)

Cooper, J.B., W.D. Purtymun, and E.C. John, July 1965. "Records of Water-Supply Wells Guaje Canyon 6, Pajarito Mesa 1, and Pajarito Mesa 2, Los Alamos, New Mexico, Basic Data Report," U.S. Geological Survey, Albuquerque, New Mexico. (Cooper et al. 1965, 008582)

David Schafer & Associates, December 2006. "Otowi 1 Assessment," report prepared for Los Alamos National Laboratory, Los Alamos, New Mexico. (David Schafer & Associates 2006, 094699)

Freeze, R.A., and J.A. Cherry, January 1979. *Groundwater*, Prentice-Hall, Inc., Englewood Cliffs, New Jersey. (Freeze and Cherry 1979, 088742)

Kleinfelder, May 2006. "Final Flow, Temperature, Fluid Resistivity and Water Quality Testing Report, Otowi-1 Water Supply Well, Los Alamos National Laboratory, Los Alamos County, New Mexico," report prepared for the U.S. Army Corps of Engineers, Project No. 49436, Albuquerque, New Mexico. (Kleinfelder 2006, 092487)

Koch, R.J., and D.B. Rogers, March 2003. "Water Supply at Los Alamos, 1998–2001," Los Alamos National Laboratory report LA-13985-PR, Los Alamos, New Mexico. (Koch and Rogers 2003, 088425)

LANL (Los Alamos National Laboratory), March 2007. "2007 General Facility Information," Los Alamos National Laboratory document LA-UR-07-1839, Los Alamos, New Mexico. (LANL 2007, 095364)

McLin, S., July 2005. "Analyses of the PM-2 Aquifer Test Using Multiple Observation Wells," Los Alamos National Laboratory report LA-14225-MS, Los Alamos, New Mexico. (McLin 2005, 090073)

METRIC Corporation, June 2008. "Testing and Evaluation of Pajarito Well No. 2," report prepared for Los Alamos County Utilities in Los Alamos, New Mexico, Los Lunas, New Mexico. (METRIC Corporation 2008, 102728)

Stone, W., D. Vaniman, P. Longmire, D. Broxton, M. Everett, R. Lawrence, and D. Larssen, April 2002. "Characterization Well R-7 Completion Report," Los Alamos National Laboratory report LA-13932-MS, Los Alamos, New Mexico. (Stone et al. 2002, 072717)

Vesselinov, V.V., 2004. "An Alternative Conceptual Model of Groundwater Flow and Transport in Saturated Zone beneath the Pajarito Plateau," Los Alamos National Laboratory document LA-UR-05-6741, Los Alamos, New Mexico. (Vesselinov 2004, 090040)



		SPINNER DOWN RUNS PUMPING CONDITION			
Job No. 13801	Company LAYNE CHRISTENSEN				
	Well PW-2				
File No.	Field LOS ALAMOS				
	County LOS ALAMOS	State NM			
Location: LOS ALAMOS NATIONAL LAB.			Other Services: STATIC TEMP DYNAMIC TEMP STOP COUNTS		
Sec.	Twp.	Rge.	Elevation 6715' above perm. datum	Elevation C.O.K. C.O.K. C.O.K.	
Permanent Datum	G.L.				
Log Measured From	G.L.	0'			
Drilling Measured From	G.L.				
Date	4-16-08				
Run Number	ONE				
Depth Driller	2300'				
Depth Logger	2278'				
Bottom Logged Interval	2278'				
Top Log Interval	980'				
Pump Set @	968'				
Time Pumping Prior to Survey	2 HR				
Pumping Water Level	933'				
Max. Recorded Temp.	96.8 F				
Pump Rate (GPM)	1029 GPM				
Time Well Ready	8:00 AM				
Time Logger on Bottom	9:00 AM				
Equipment Number	PS-4				
Location	L.A.				
Recorded By	LAPORTE				
Witnessed By	R. COOK				
Perforation Record			Perforation Record		
Type	Slot Size	From	To	Type	Slot Size
Louvers	N/A	1004'	2280'	2"	PVC
				From	To
				0	999'
Casing Record			Casing Record		
Surface String	Size	Wgt/Ft	Top	Bottom	
Camera Tube					
Production String	14"	CSG	0	2300'	
Liner					
<<< Fold Here >>>					
<p>All interpretations are opinions based on inferences from electrical or other measurements and Pacific Surveys cannot and do not guarantee the accuracy or correctness of any interpretation, and we shall not, except in the case of gross or willful negligence on our part, be liable or responsible for any loss, costs, damages, or expenses incurred or sustained by anyone resulting from any interpretation made by any of our officers, agents or employees. These interpretations are also subject to Pacific Surveys' general terms and conditions set out in our current Price Schedule.</p>					
Comments					
UNABLE TO GET SLOWRUN TO BOTTOM.					
Sensor	Offset (ft)	Schematic		Description	Len (ft)
					

Figure J-2.0-1 Tool velocity and spinner logs during three test runs



Database File:	13801.db
Dataset Pathname:	Layne/LosAlimo/run1/Spn
Presentation Format:	spin
Dataset Creation:	Wed Apr 16 14:24:04 2008 by Log Open-Cased 071220
Charted by:	Depth in Feet scaled 1:240

0	LS (ft/min) 150	CSG SCHDL (ft)	dspn	0	Spinner Down Run (cps)
0	LS (ft/min) 150		(cps)	0	Spinner Down Run (cps)
0	LS (ft/min) 150		-0.1 -0.8	0	Spinner Down Run (cps)

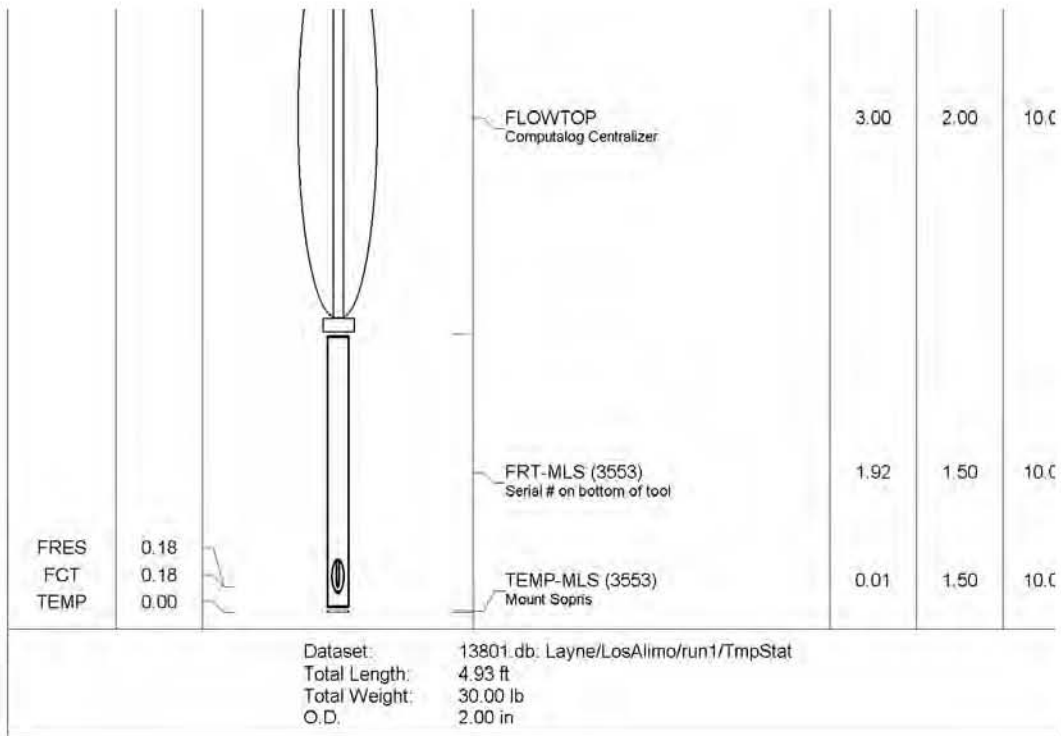
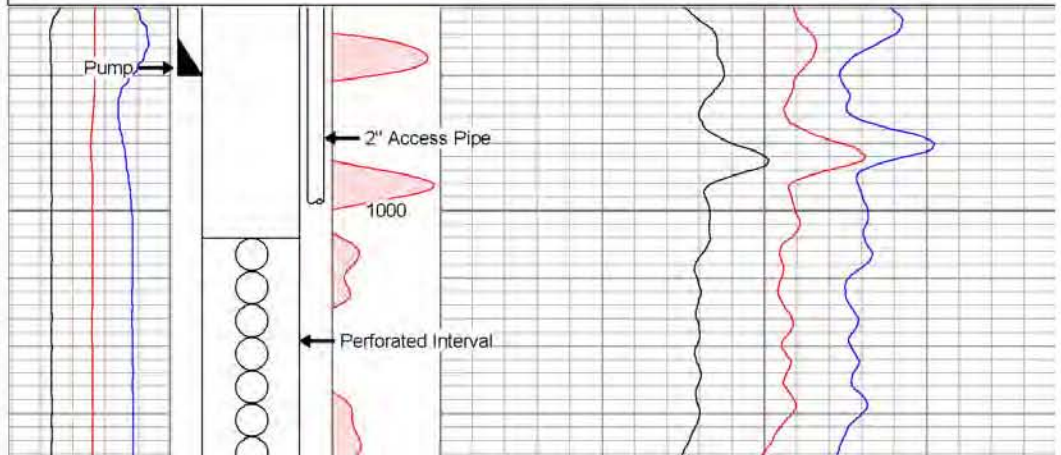

Figure J-2.0-1 (continued)

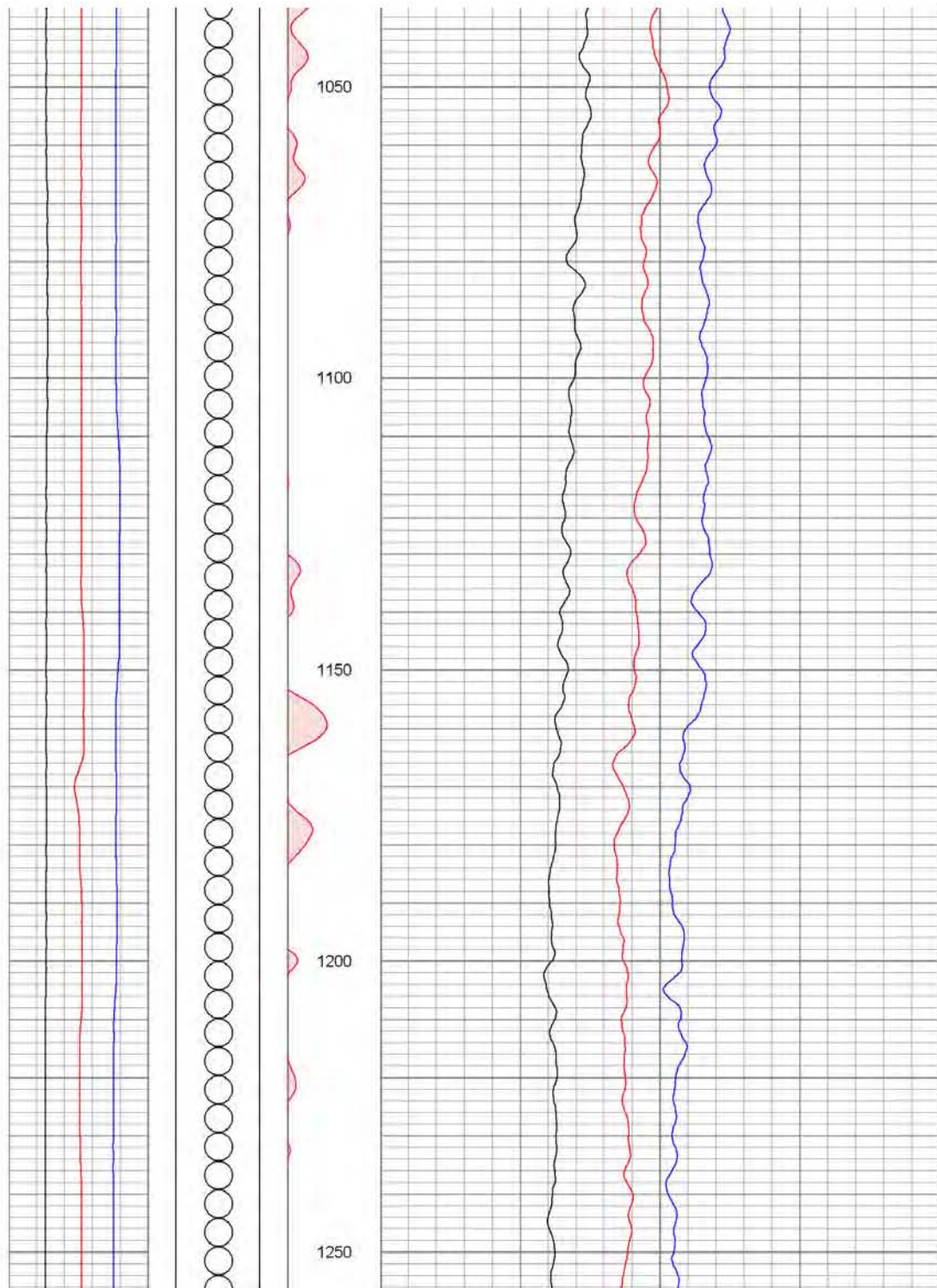

Figure J-2.0-1 (continued)

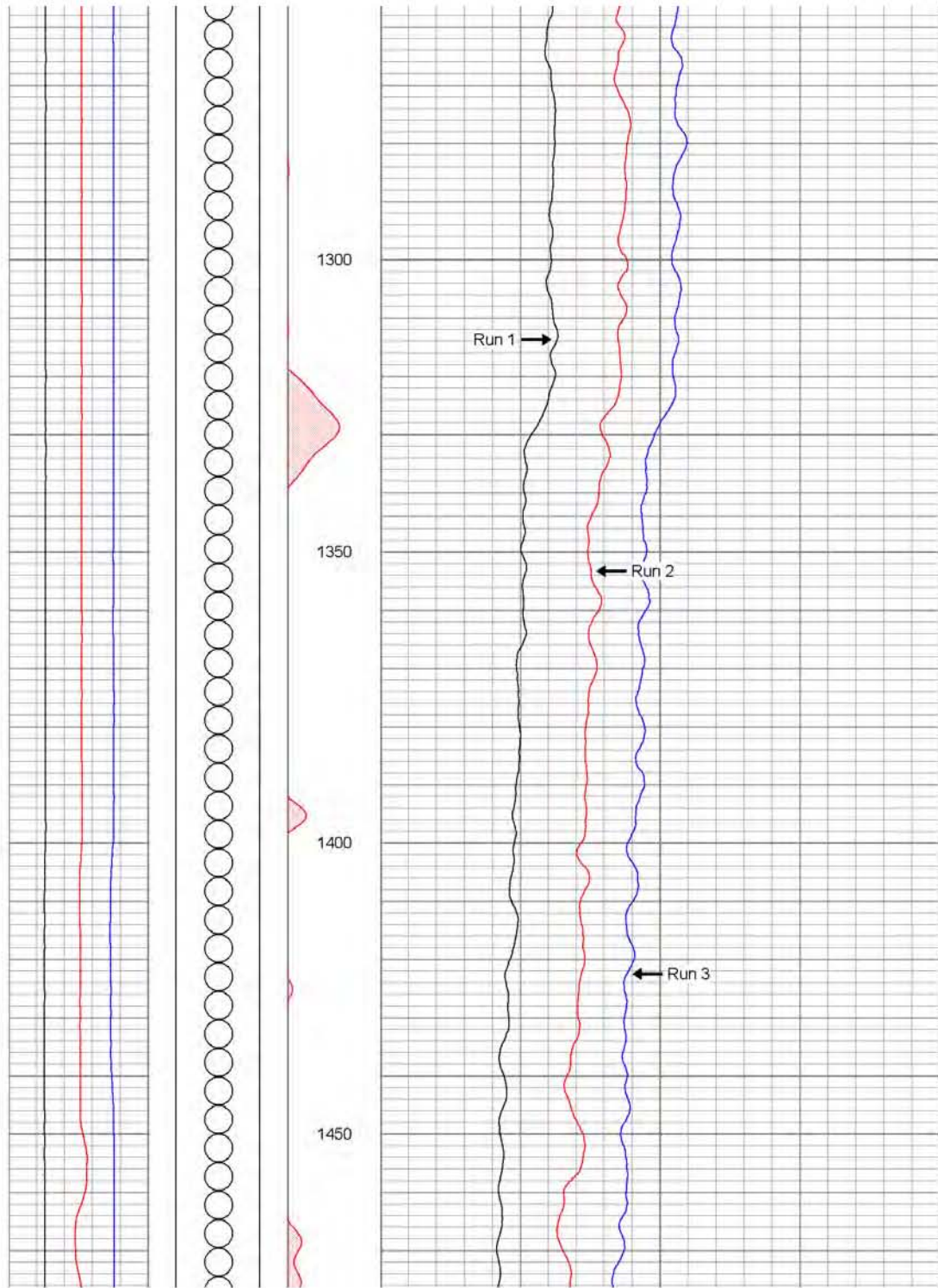

Figure J-2.0-1 (continued)

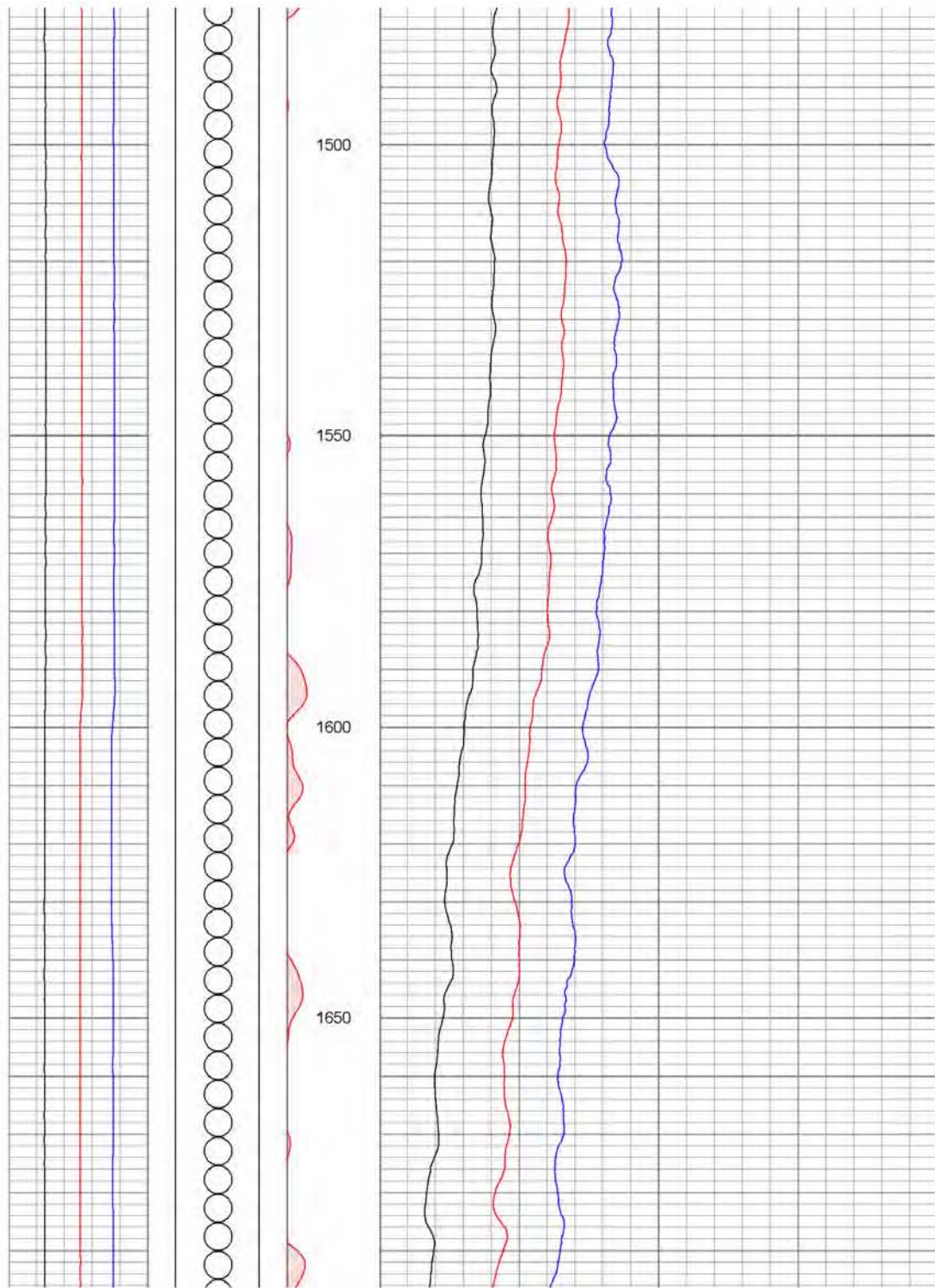

Figure J-2.0-1 (continued)

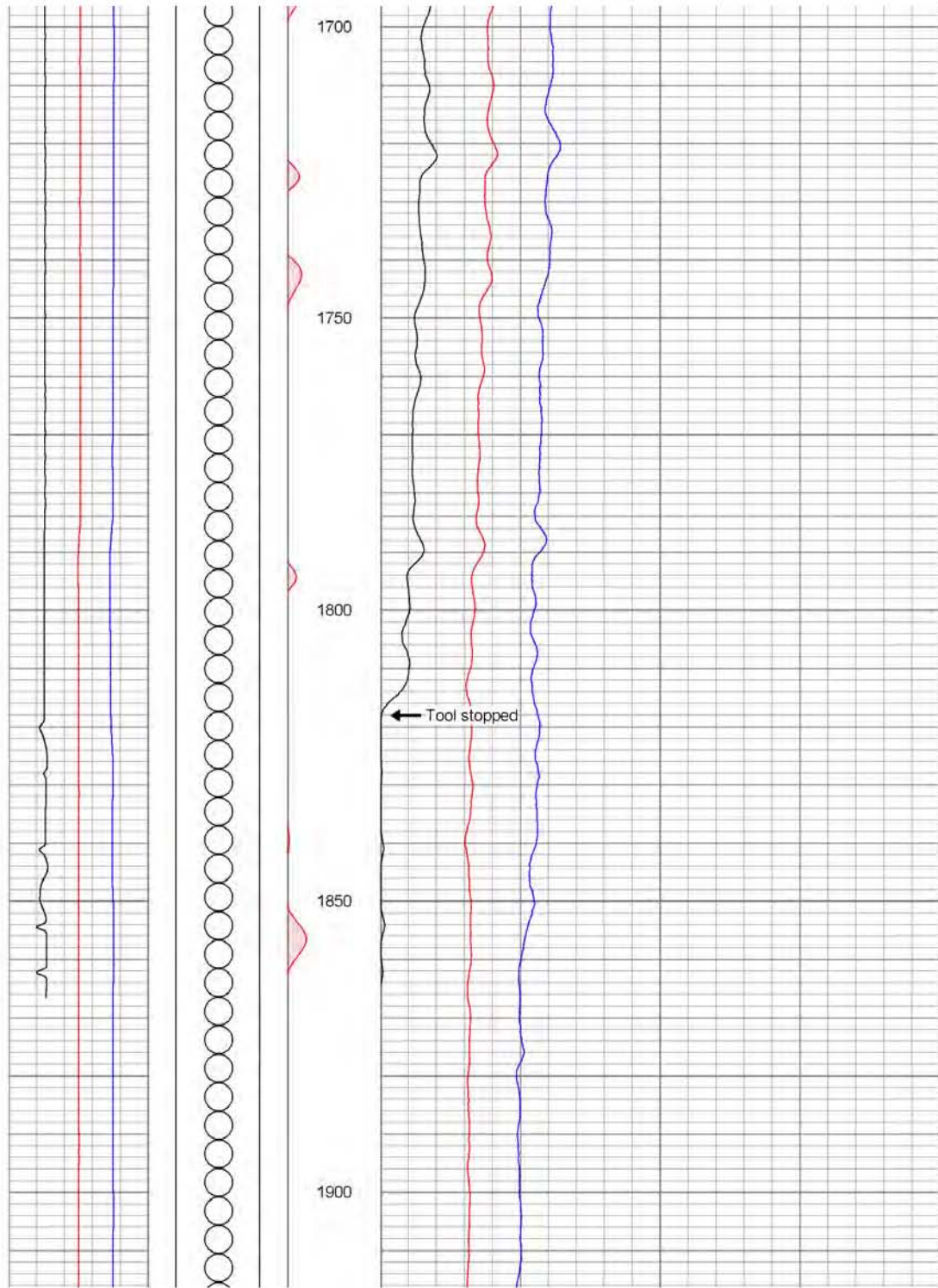

Figure J-2.0-1 (continued)

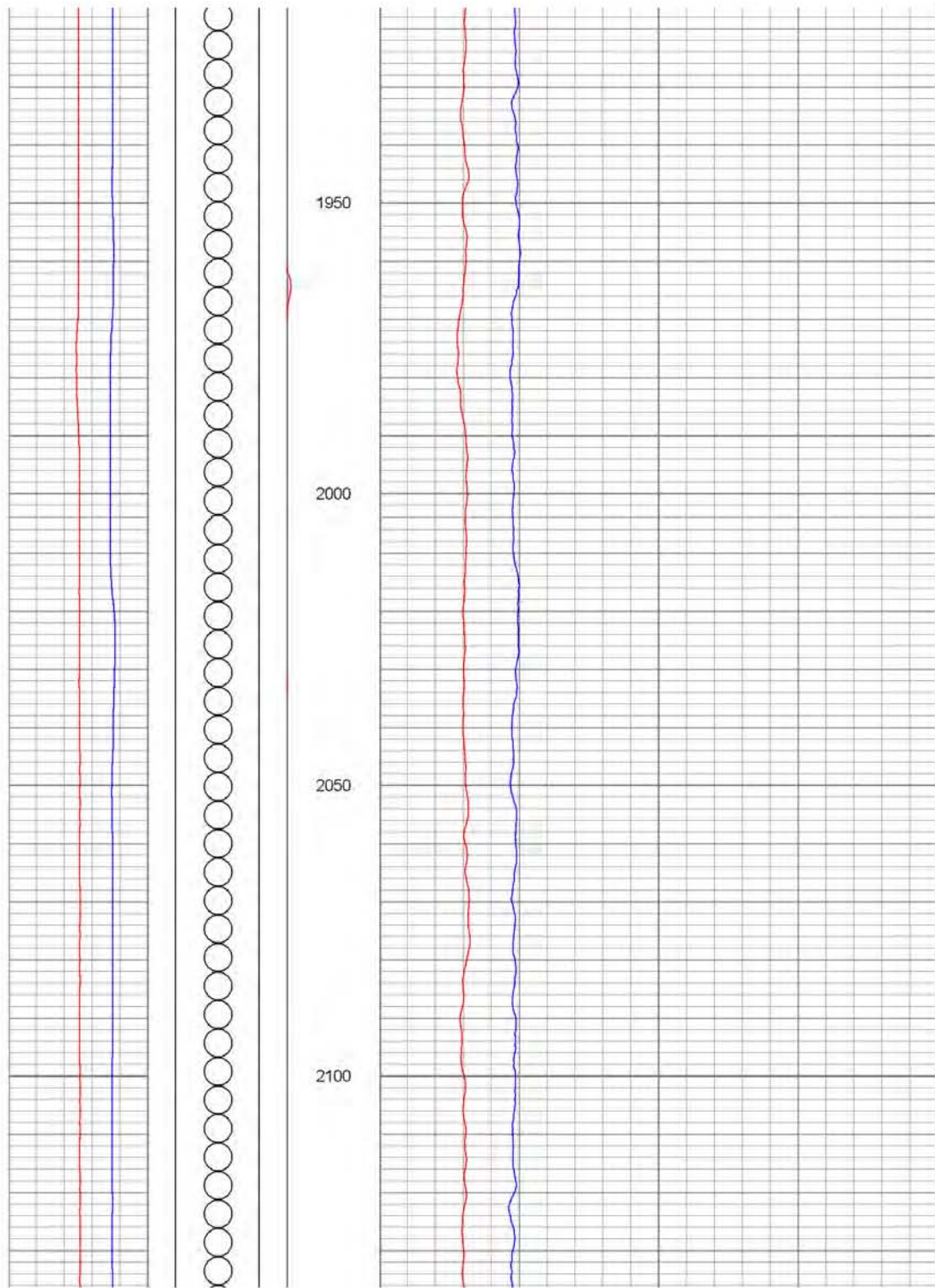

Figure J-2.0-1 (continued)

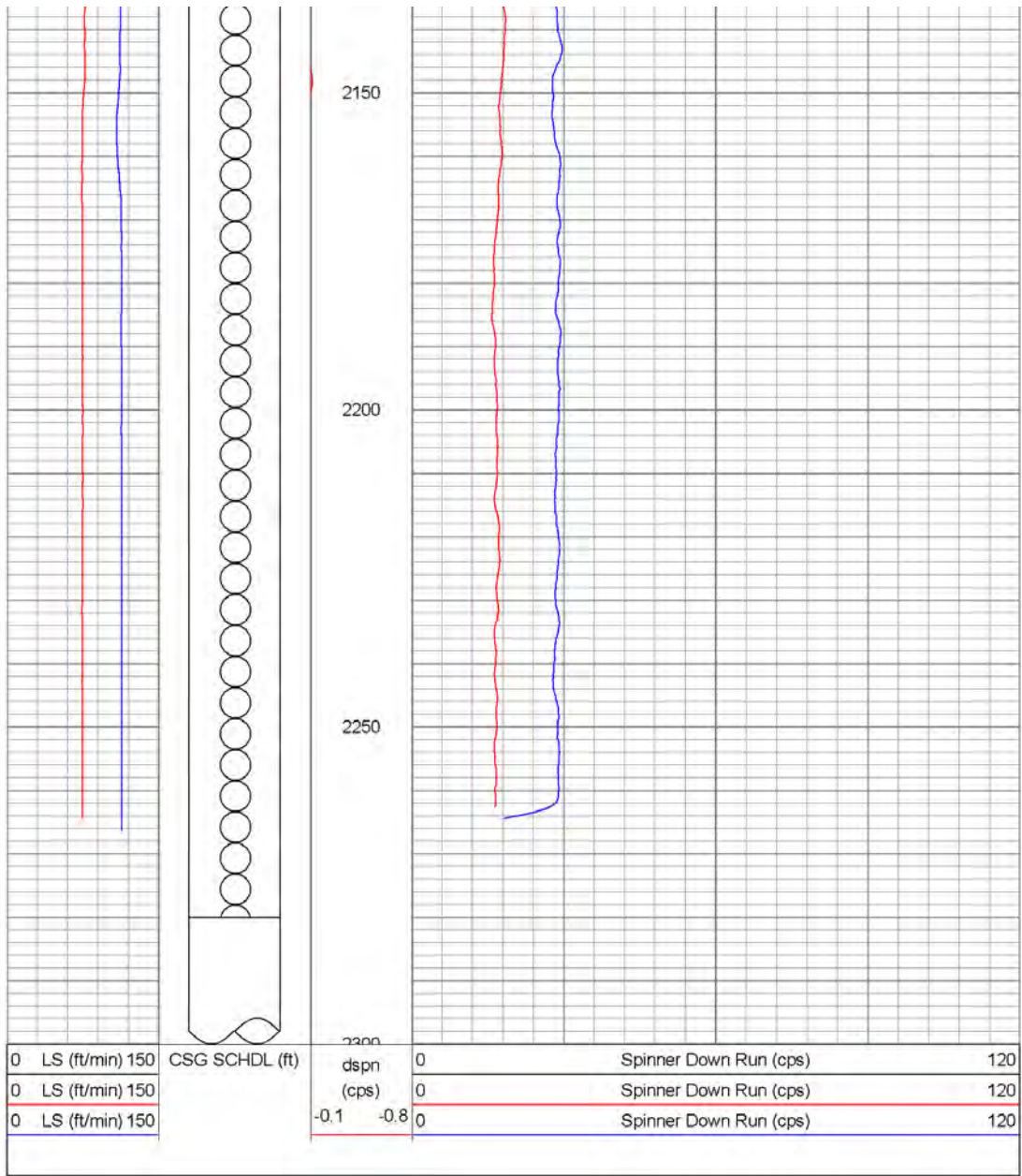

Figure J-2.0-1 (continued)

PACIFIC SURVEYS		STATIC TEMPERATURE DYNAMIC TEMPERATURE					
Job No. 13801	Company LAYNE CHRISTENSEN Well PW-2 Field LOS ALAMOS County LOS ALAMOS State NM						
Location: LOS ALAMOS NATIONAL LAB.			Other Services: DYNAMIC TEMP DYNAMIC SPINNER STOP COUNTS				
Sec.	Twp.	Rge.	Permanent Datum G.L. Elevation 6715'		Elevation		
			Log Measured From G.L. 0' above perm. datum		K.D.B. G.L.		
			Drilling Measured From G.L.				
Date	4-16-08		4-16-08				
Run Number	ONE		TWO				
Depth Driller	2300'		2300'				
Depth Logger	2278'		2278'				
Bottom Logged Interval	2278'		2278'				
Top Log Interval	980'		980'				
Pump Set @	968'		968'				
Time Pumping Prior to Survey	STATIC		1 HR.				
Density / Viscosity	N/A		N/A				
Max. Recorded Temp.	96.8 F		97.4 F				
Pump Rate (GPM)	STATIC		1100 GPM				
Time Well Ready	8:00 AM		2:00 PM				
Time Logger on Bottom	9:00 AM		3:00 PM				
Equipment Number	PS-4		PS-4				
Location	L.A.		L.A.				
Recorded By	LAPORTE		LAPORTE				
Witnessed By	R. COOK		R. COOK				
Borehole Record			Tubing Record				
Run Number	Bit	From	To	Size	Weight	From	To
				2"	PVC	0	999'
Casing Record		Size	Wgt/Ft	Top	Bottom		
Surface String							
Prot. String							
Production String		14"	CSG	0	2300'		
Liner							

<<< Fold Here >>>

All interpretations are opinions based on inferences from electrical or other measurements and Pacific Surveys cannot and do not guarantee the accuracy or correctness of any interpretation, and we shall not, except in the case of gross or willful negligence on our part, be liable or responsible for any loss, costs, damages, or expenses incurred or sustained by anyone resulting from any interpretation made by any of our officers, agents or employees. These interpretations are also subject to Pacific Surveys' general terms and conditions set out in our current Price Schedule.

Comments

LOUVERS: 1004'-2280'

Sensor	Offset (ft)	Schematic	Description	Len (ft)	OD (in)	Wt (lb)
						

Figure J-2.0-2 Static and dynamic temperature logs



Database File: 13801.db
 Dataset Pathname: Layne/LosAlimo/run1/TmpStat.1
 Presentation Format: temp4
 Dataset Creation: Wed Apr 16 07:43:55 2008 by Calc Open-Cased 071220
 Charted by: Depth in Feet scaled 1:240

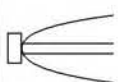
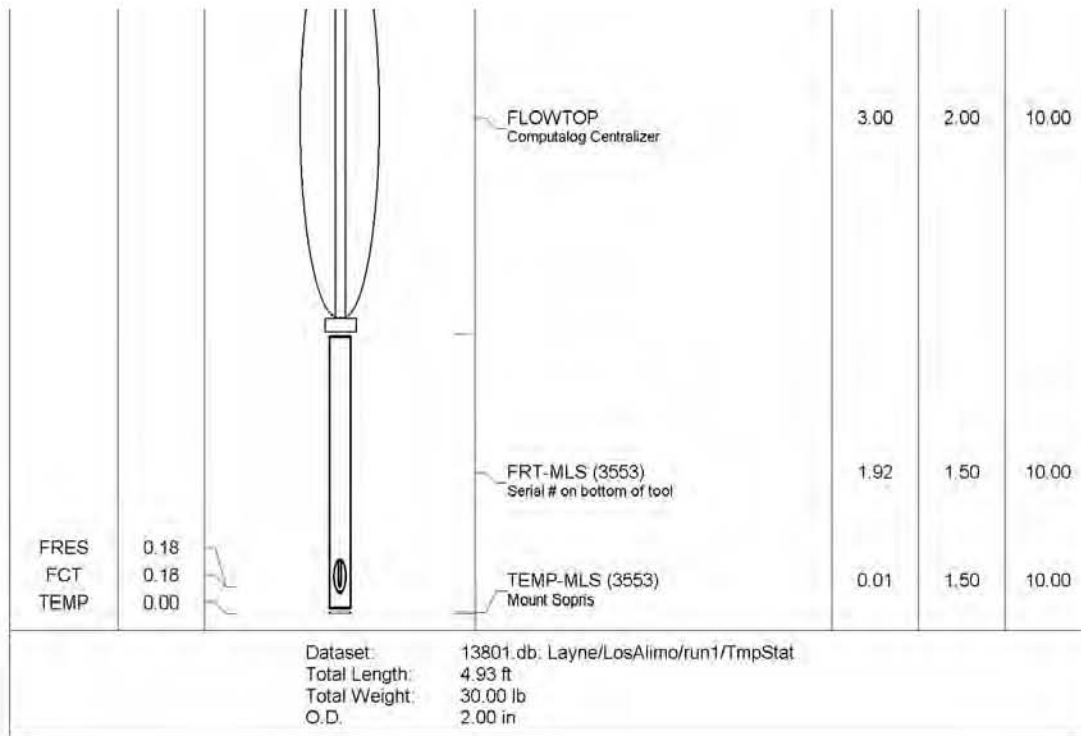
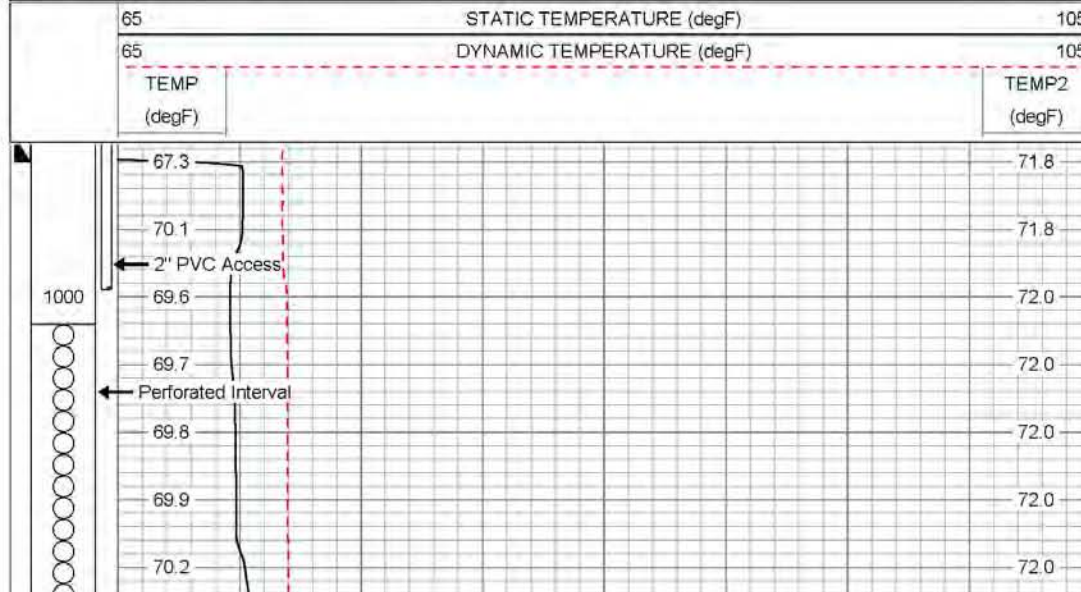

Figure J-2.0-2 (continued)

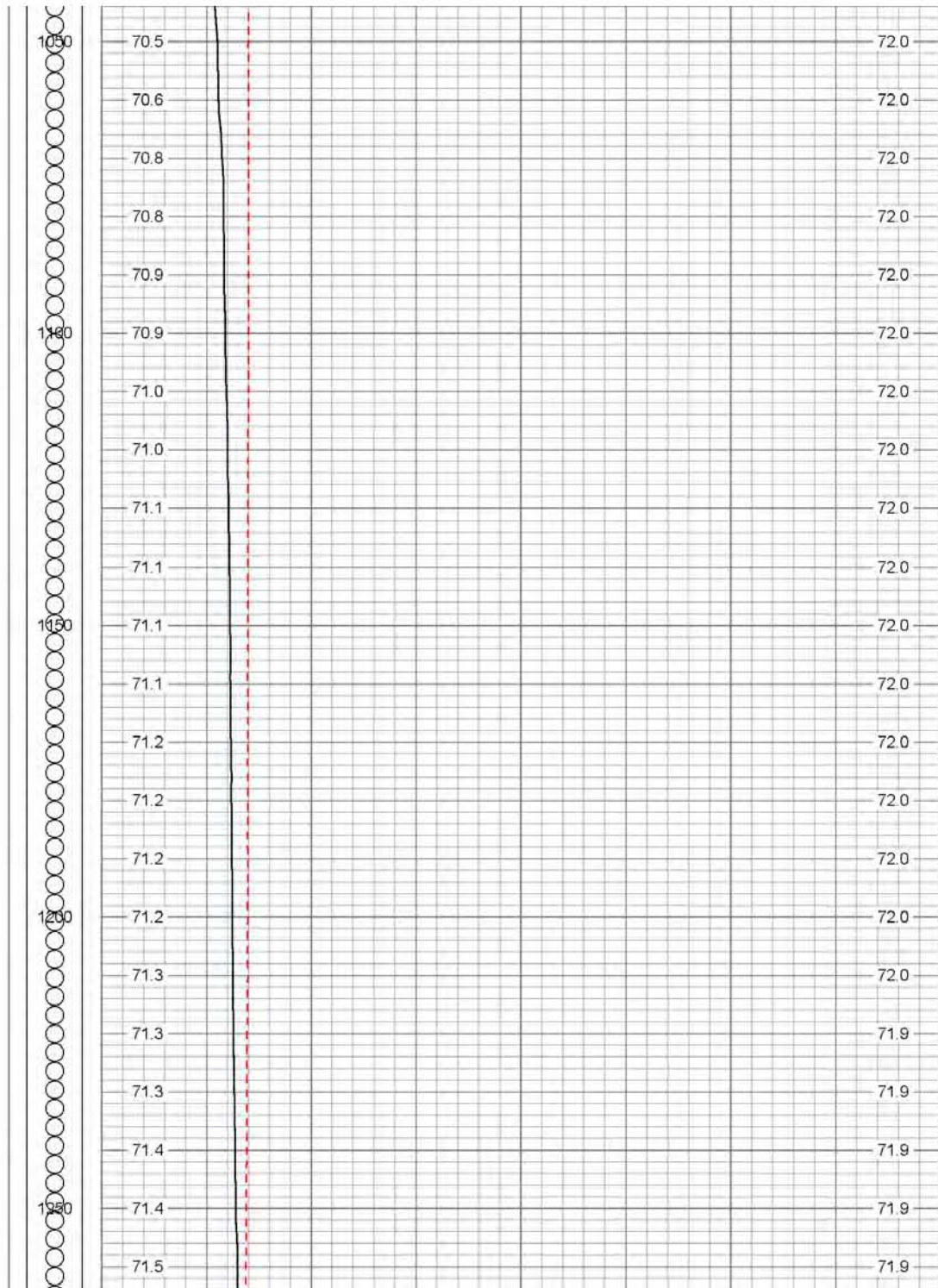

Figure J-2.0-2 (continued)

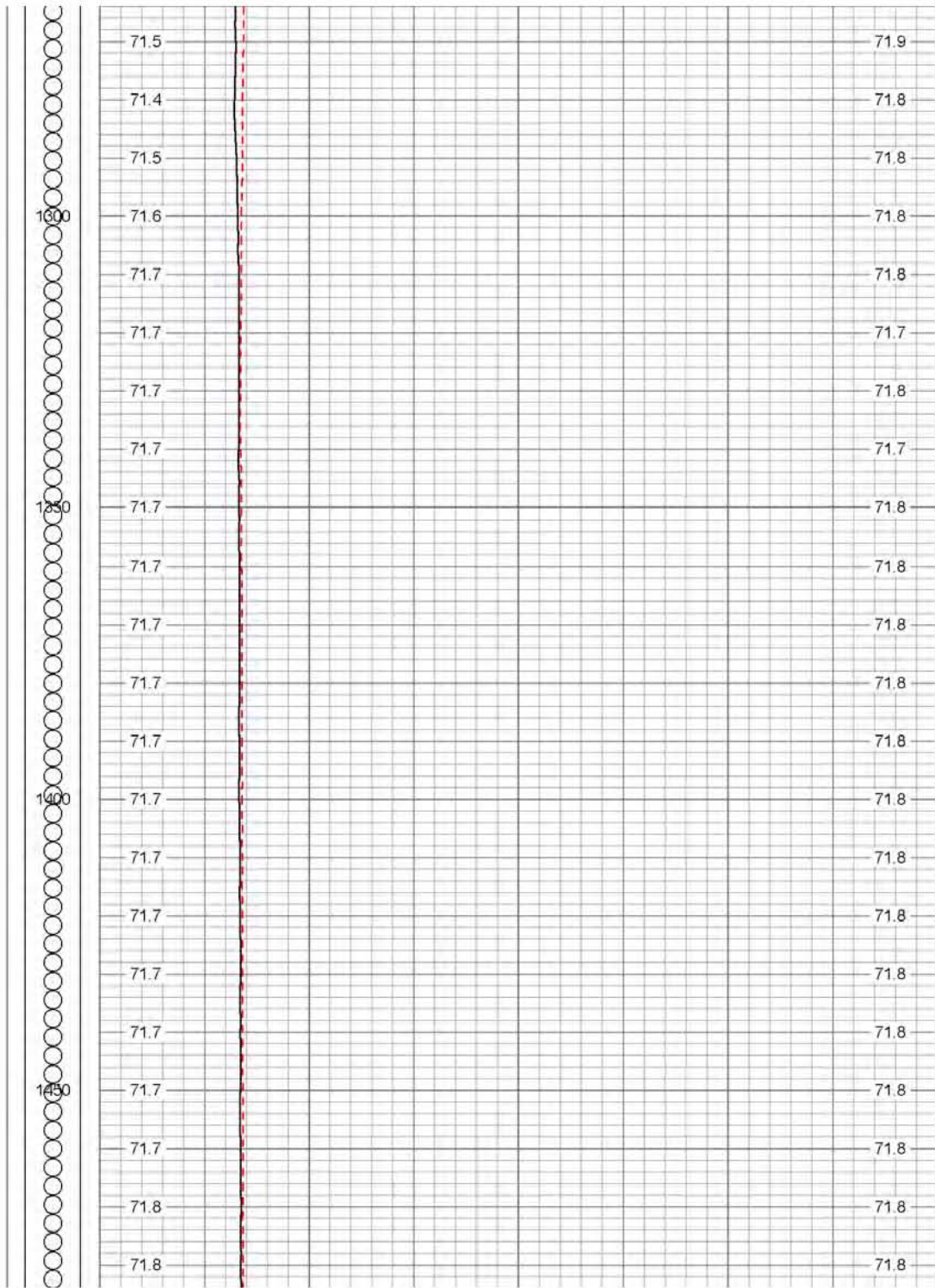

Figure J-2.0-2 (continued)

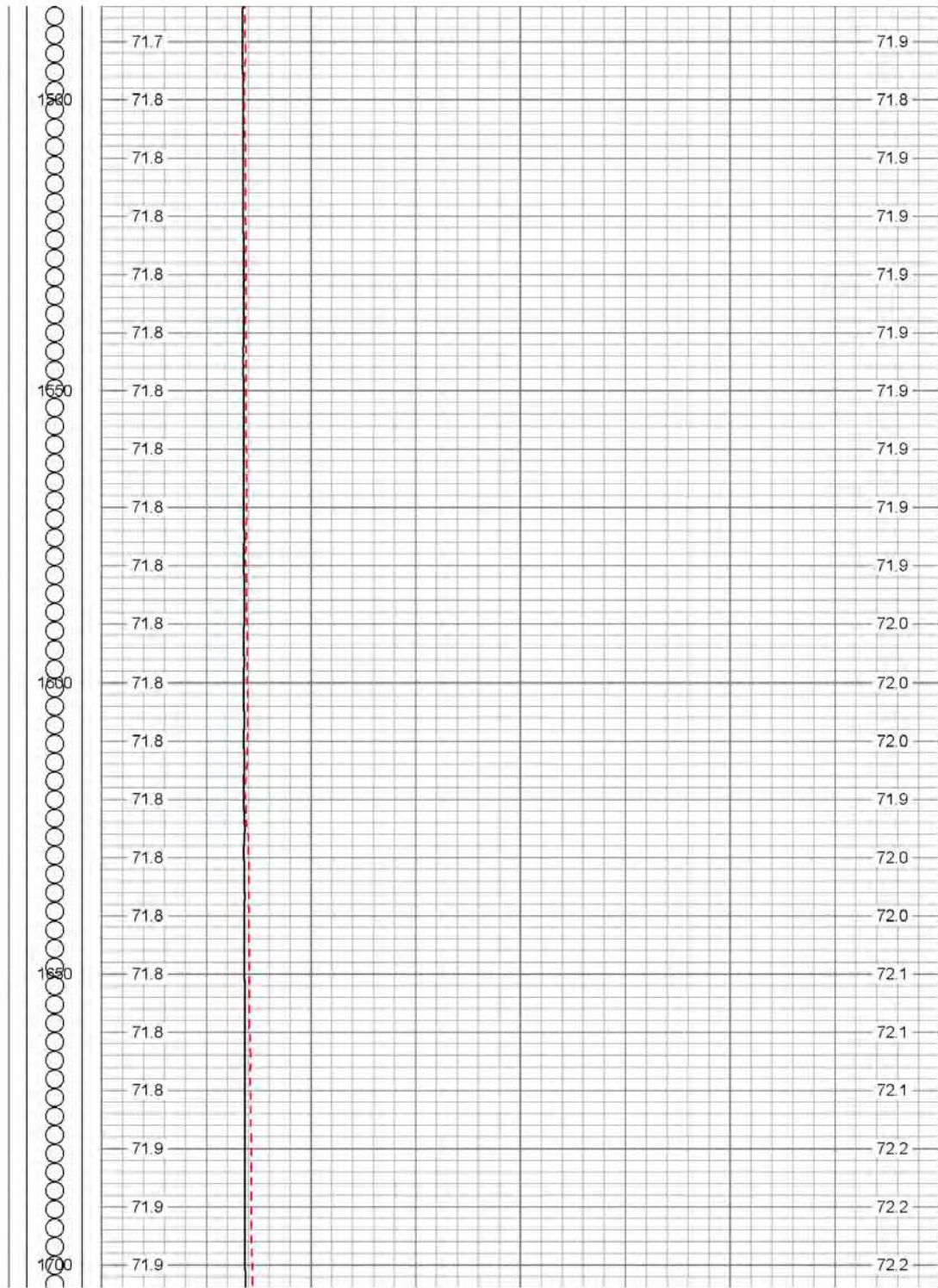

Figure J-2.0-2 (continued)

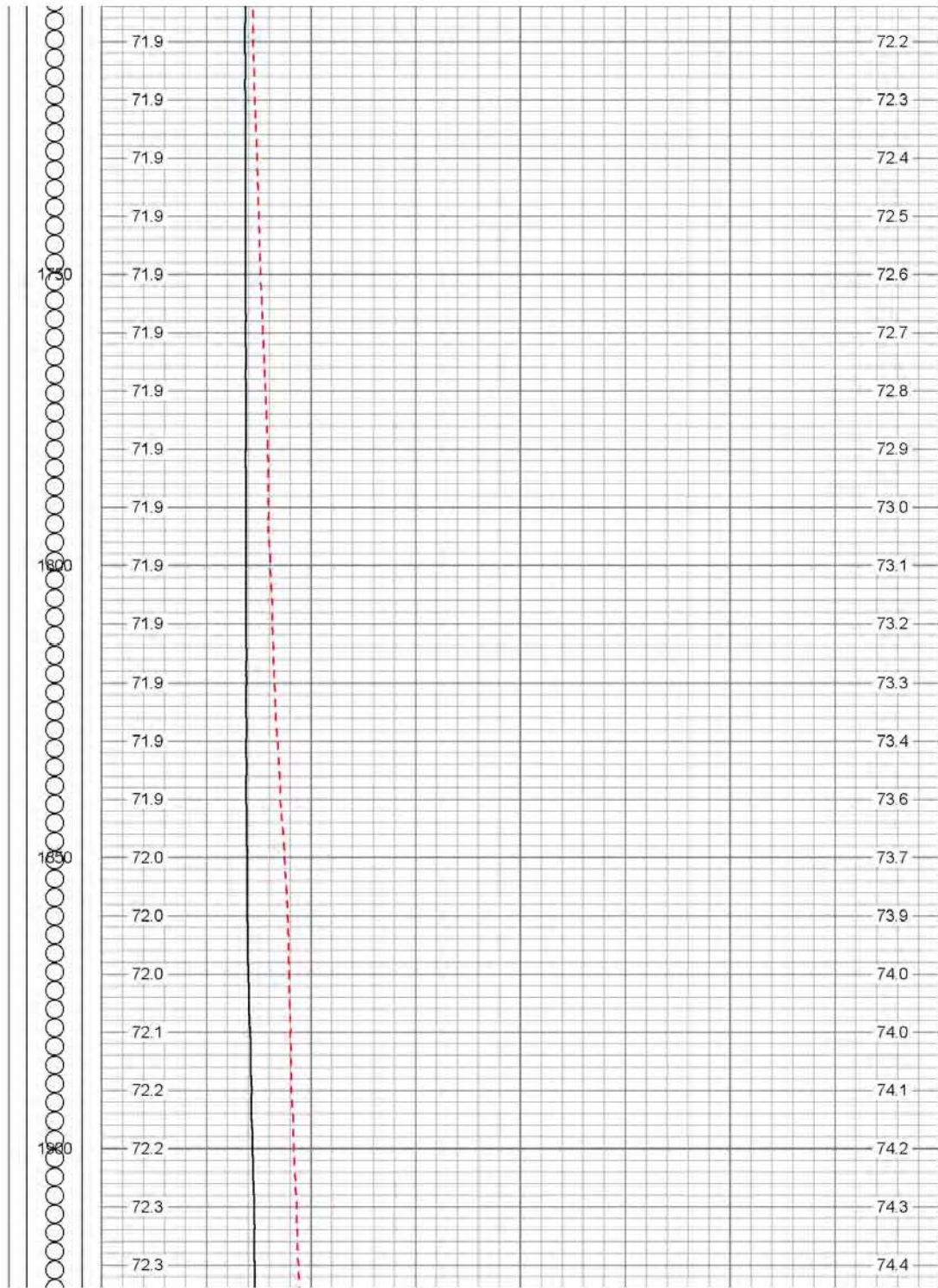

Figure J-2.0-2 (continued)

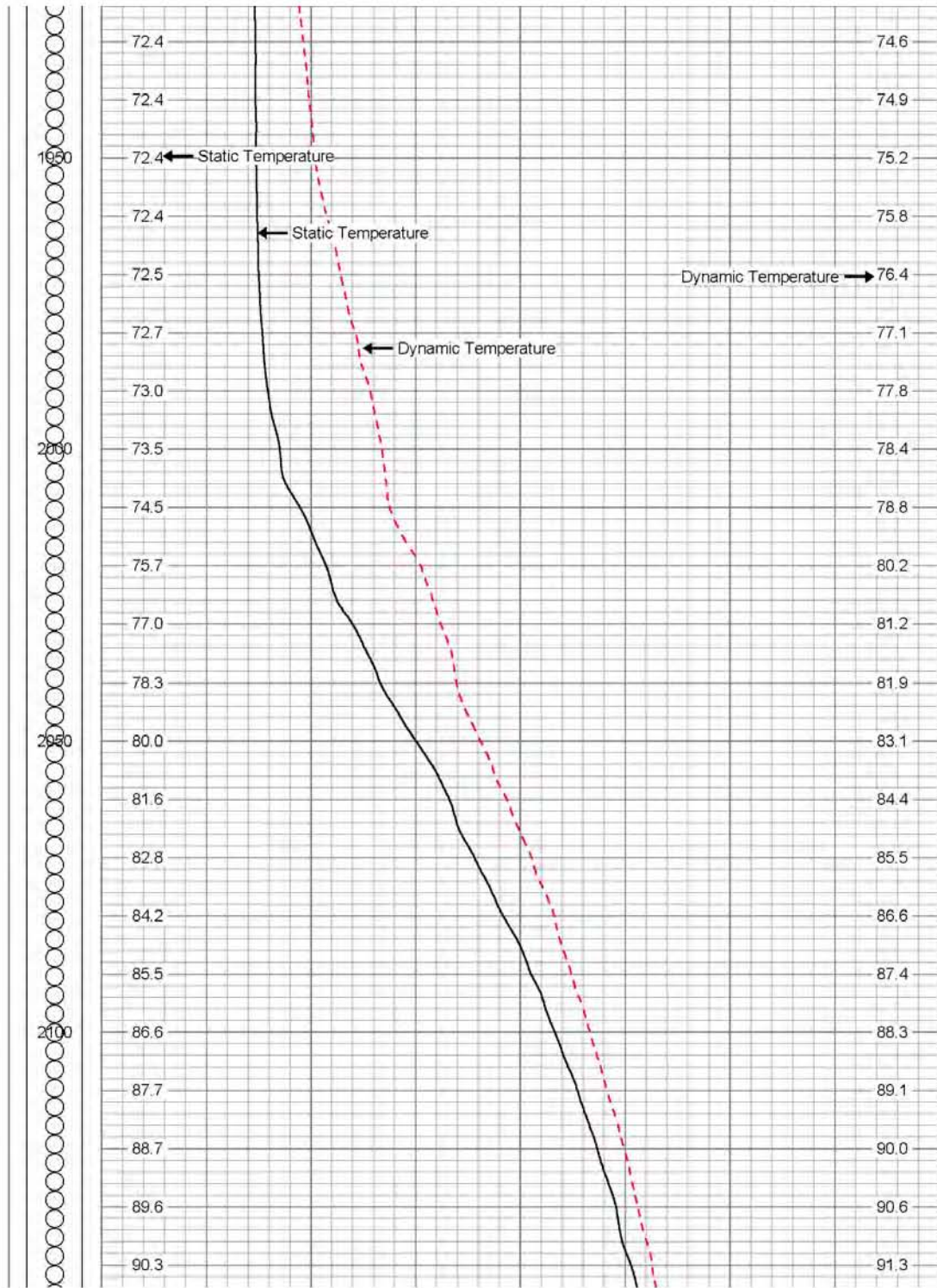

Figure J-2.0-2 (continued)



Figure J-2.0-2 (continued)

PACIFIC SURVEYS		TEMPERATURE DIFFERENTIAL TEMPERATURE NON-PUMPING CONDITION					
Job No. 13801	Company LAYNE CHRISTENSEN						
	Well PW-2						
	Field LOS ALAMOS						
	County LOS ALAMOS			State NM			
Location: LOS ALAMOS NATIONAL LAB.				Other Services: DYNAMIC TEMP DYNAMIC SPINNER STOP COUNTS			
Sec.	Twp.	Rge.	Permanent Datum G.L. Elevation 6715'		Elevation		
			Log Measured From G.L. 0' above perm. datum		K.D.B. G.L.		
			Drilling Measured From G.L.				
Date	4-16-08						
Run Number	ONE						
Depth Driller	2300'						
Depth Logger	2278'						
Bottom Logged Interval	2278'						
Top Log Interval	980'						
Pump Set @	968'						
Time Pumping Prior to Survey	STATIC						
Density / Viscosity	N/A						
Max. Recorded Temp.	96.8 F						
Pump Rate (GPM)	STATIC						
Time Well Ready	8:00 AM						
Time Logger on Bottom	9:00 AM						
Equipment Number	PS-4						
Location	L.A.						
Recorded By	LAPORTE						
Witnessed By	R. COOK						
Borehole Record			Tubing Record				
Run Number	Bit	From	To	Size 2"	Weight PVC	From 0	To 999'
Casing Record		Size	Wg/VFt	Top	Bottom		
Surface String							
Prot. String							
Production String		14"	CSG	0	2300'		
Liner							

<<< Fold Here >>>

All interpretations are opinions based on inferences from electrical or other measurements and Pacific Surveys cannot and do not guarantee the accuracy or correctness of any interpretation, and we shall not, except in the case of gross or willful negligence on our part, be liable or responsible for any loss, costs, damages, or expenses incurred or sustained by anyone resulting from any interpretation made by any of our officers, agents or employees. These interpretations are also subject to Pacific Surveys' general terms and conditions set out in our current Price Schedule.

Comments

LOUVERS: 1004'-2280'

Sensor	Offset (ft)	Schematic	Description	Len (ft)	OD (in)	Wt (lb)
						

Figure J-2.0-3 Temperature differential between static and dynamic temperature logs



Database File: 13801.db
 Dataset Pathname: Layne/LosAlimo/run1/TmpStat.1
 Presentation Format: temp4
 Dataset Creation: Wed Apr 16 07:43:55 2008 by Calc Open-Cased 071220
 Charted by: Depth in Feet scaled 1:240

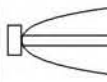
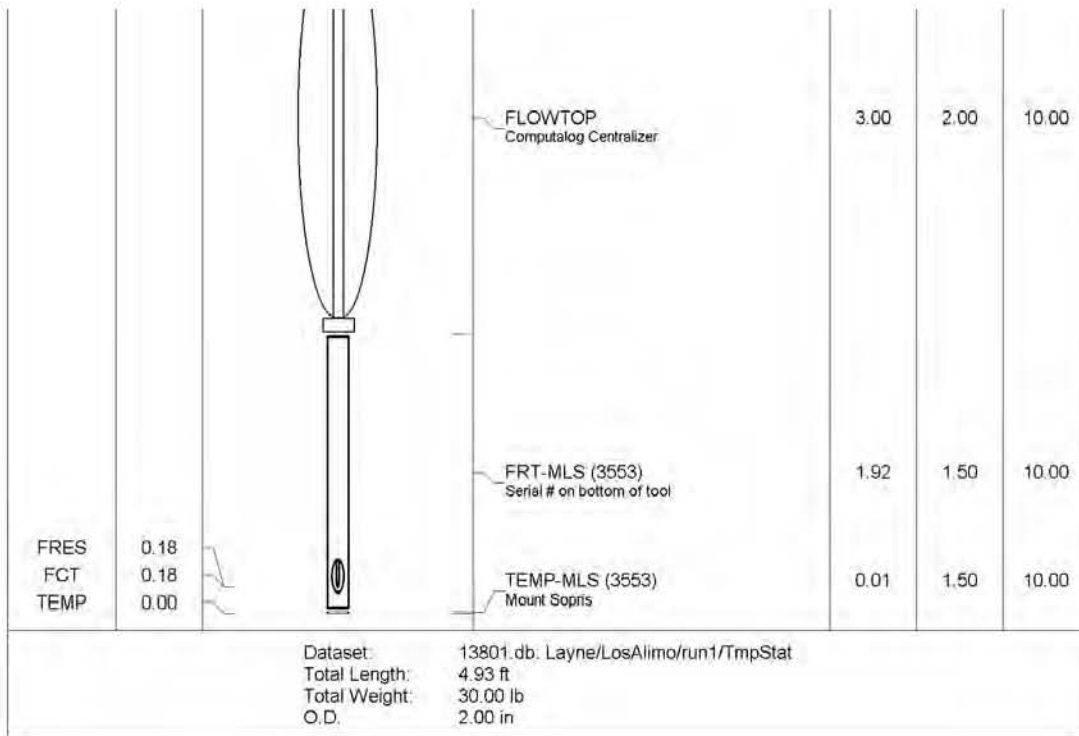
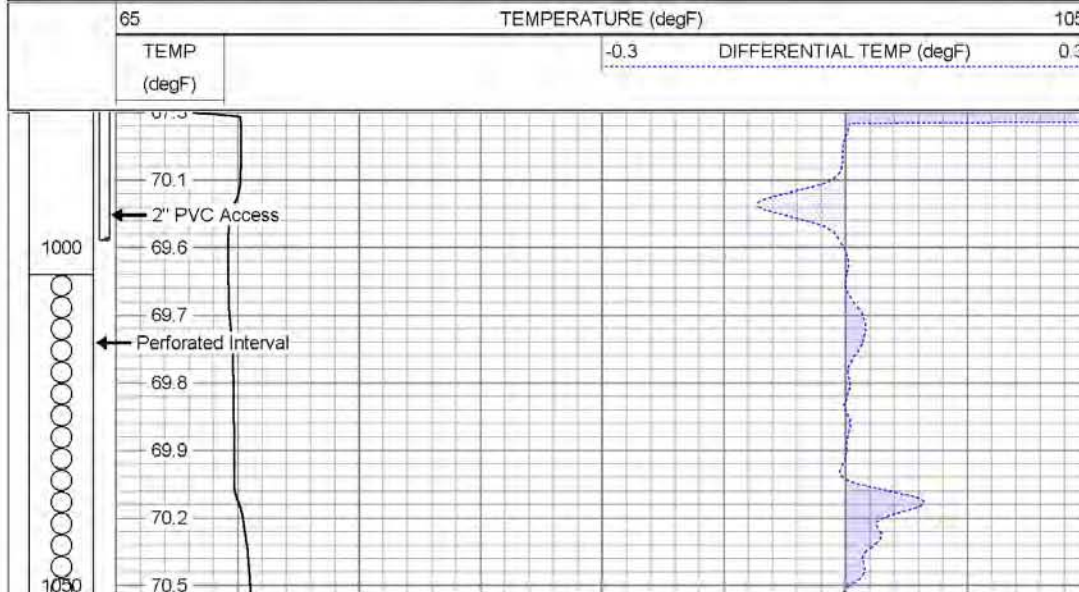

Figure J-2.0-3 (continued)

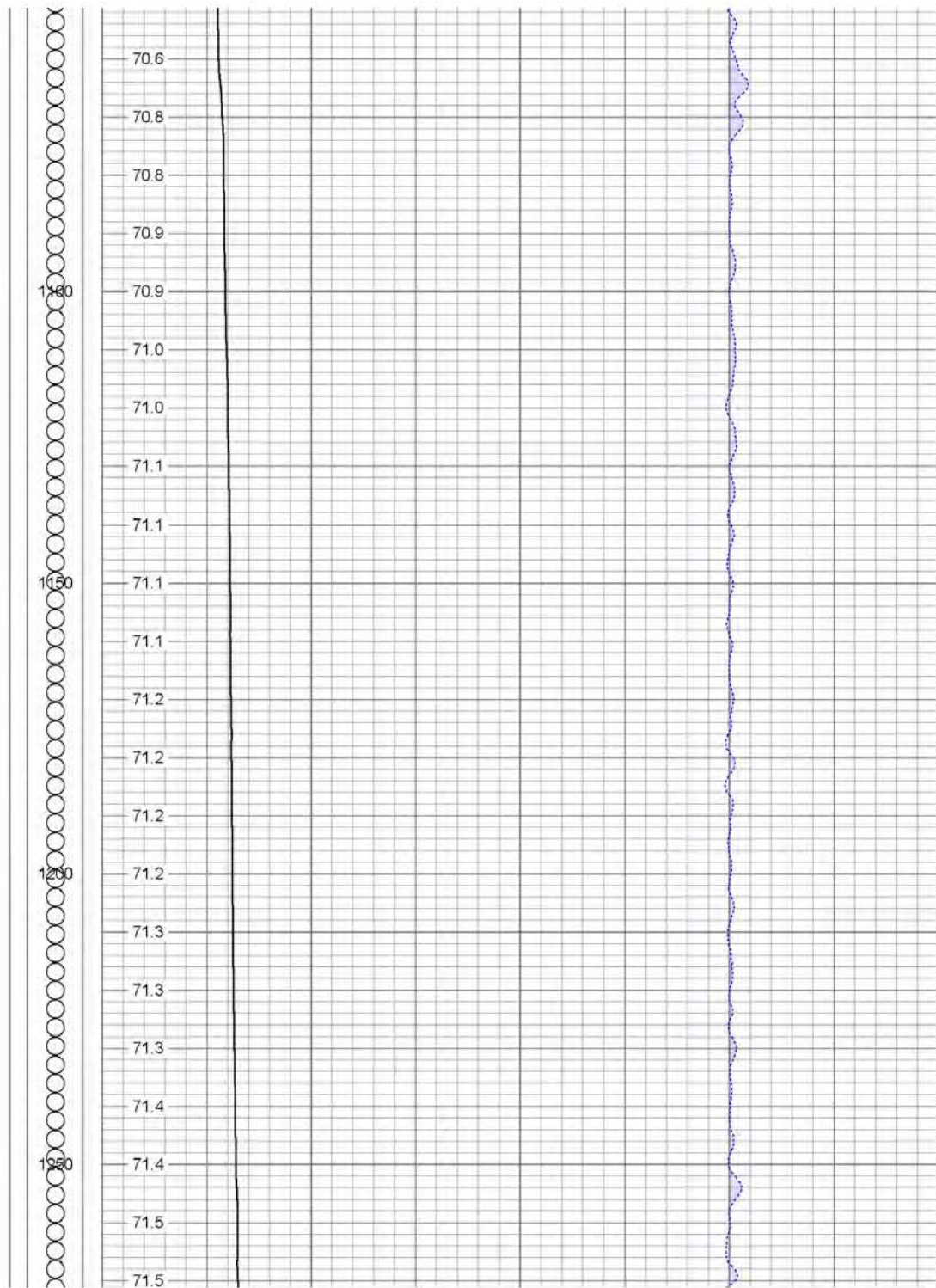

Figure J-2.0-3 (continued)

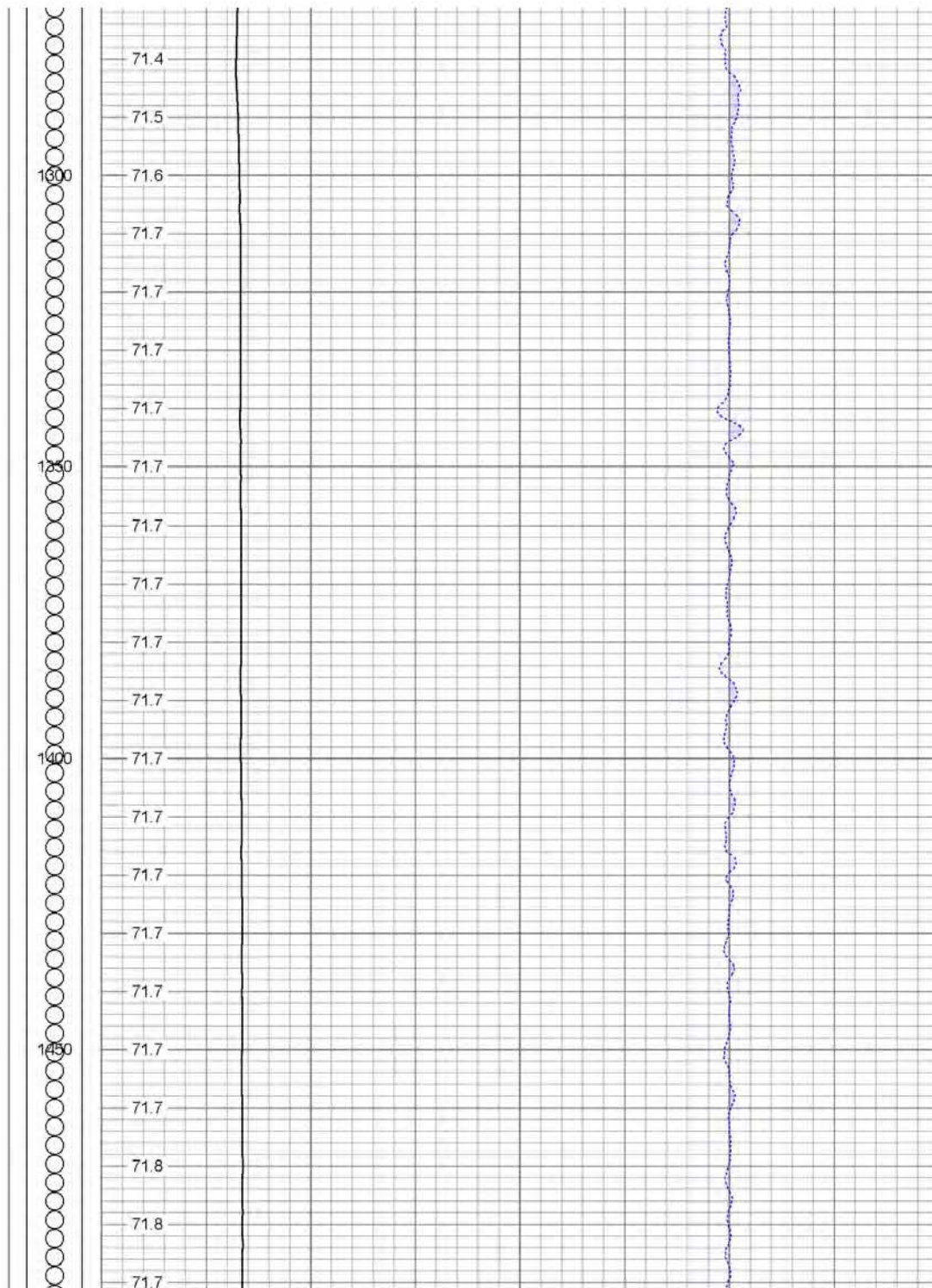

Figure J-2.0-3 (continued)

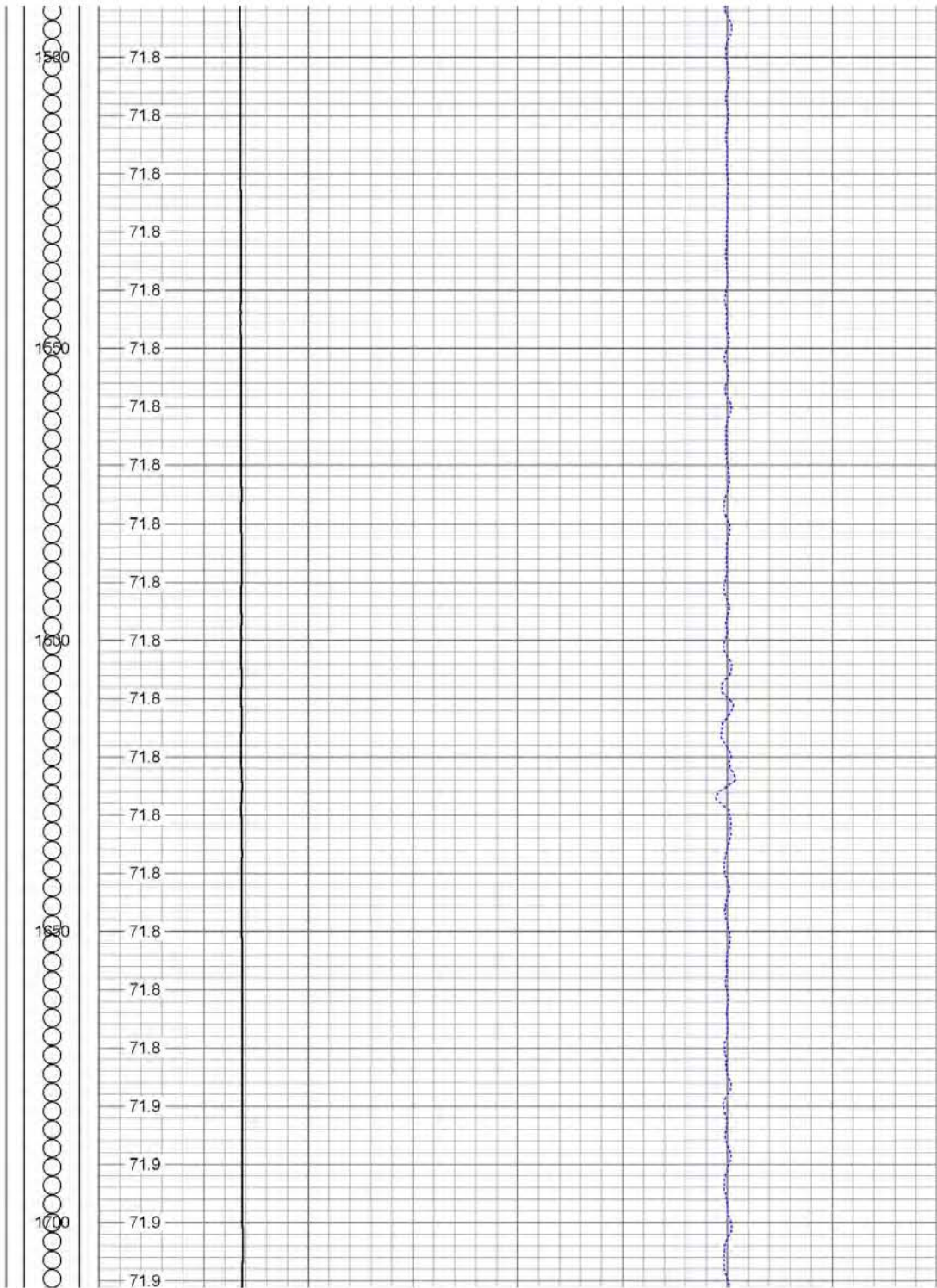

Figure J-2.0-3 (continued)

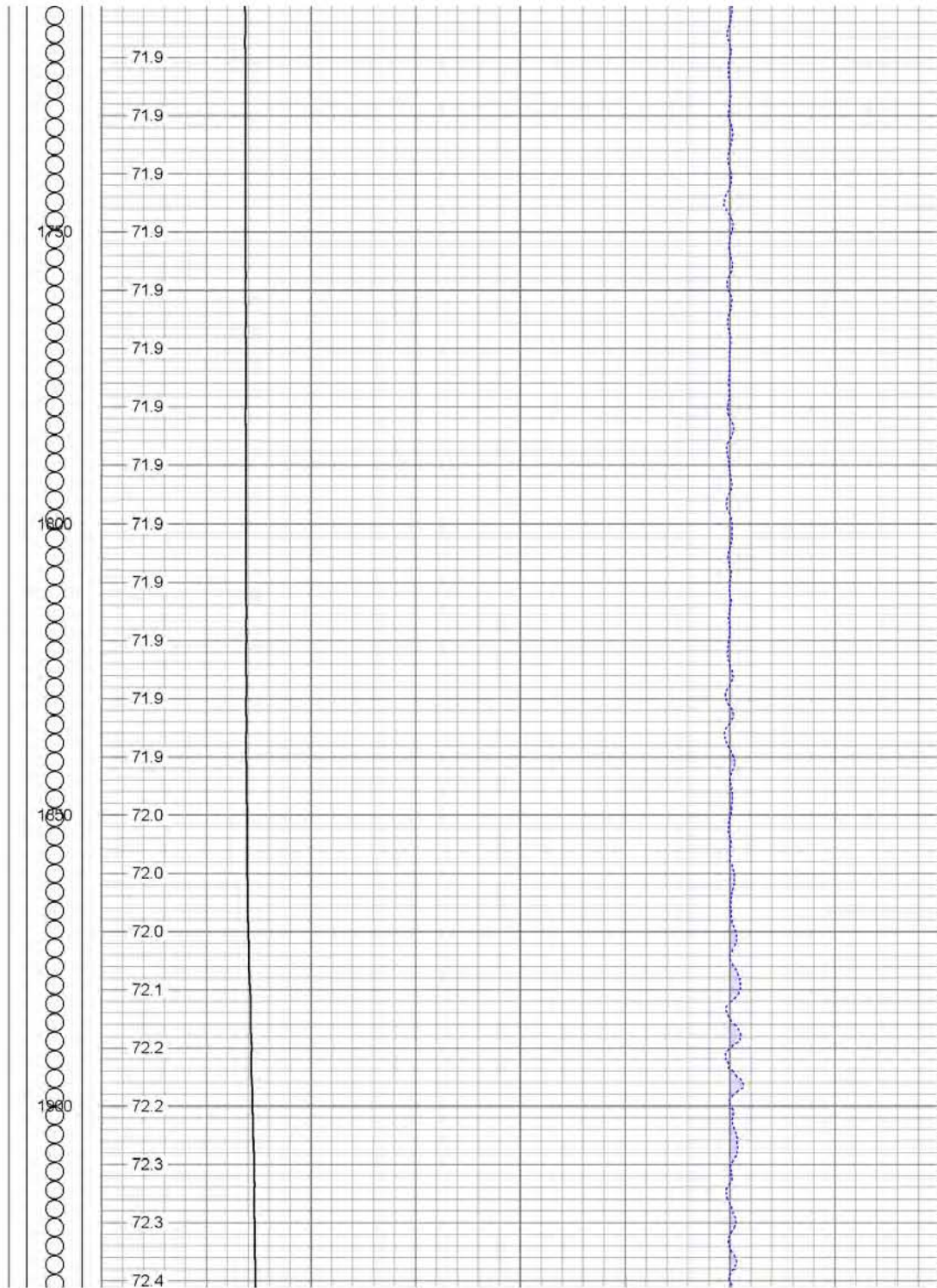

Figure J-2.0-3 (continued)

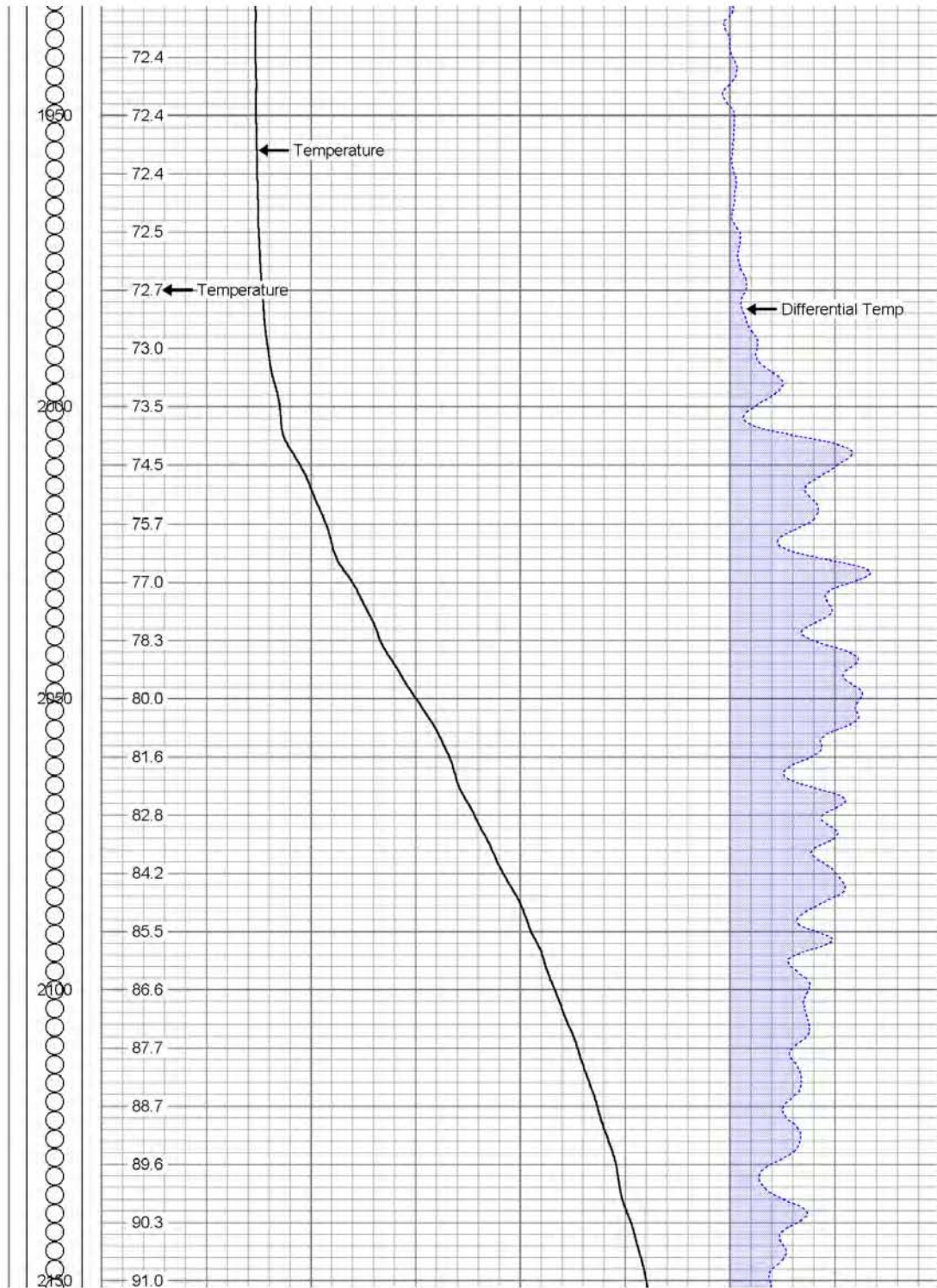

Figure J-2.0-3 (continued)

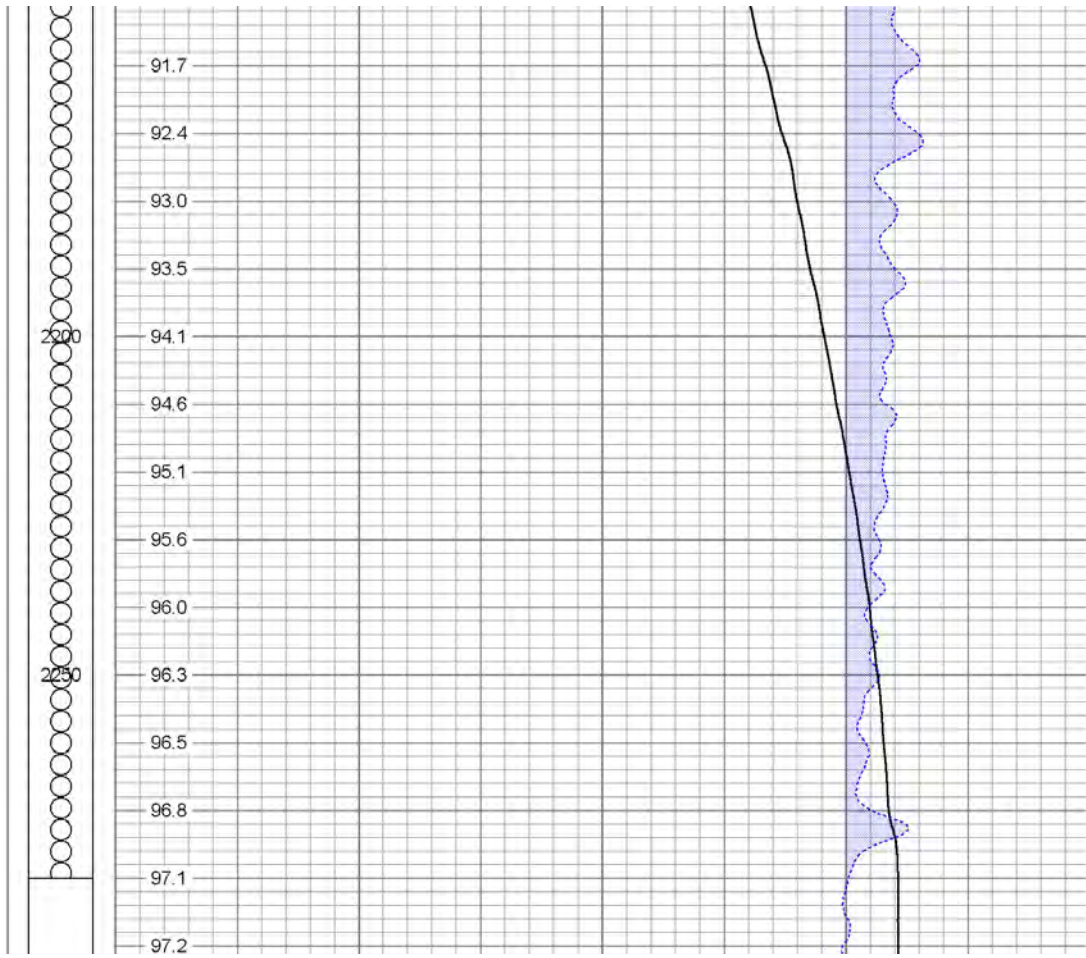

Figure J-2.0-3 (continued)

		FLUID VELOCITY SPINNER ANALYSIS PUMPING CONDITION			
Job No. 13801	Company LAYNE CHRISTENSEN				
	Well PW-2				
File No.	Field LOS ALAMOS		State NM		
Location: LOS ALAMOS NATIONAL LAB.			Other Services: STATIC TEMP DYNAMIC TEMP DYNAMIC SPINNER STOP COUNTS		
Sec.	Twp.	Rge.	Elevation 6715'	Elevation	
Permanent Datum	G.L.		0'	above perm. datum	
Log Measured From	G.L.				
Drilling Measured From	G.L.				
Date	4-16-08				
Run Number	ONE				
Depth Driller	2300'				
Depth Logger	2278'				
Bottom Logged Interval	2278'				
Top Log Interval	960'				
Pump Set @	960'				
Time Pumping Prior to Survey	2 HRS.				
Pumping Water Level	933'				
Max. Recorded Temp.	96.8 F				
Pump Rate (GPM)	1029 GPM				
Time Well Ready	8:00 AM				
Time Logger on Bottom	9:00 AM				
Equipment Number	PS-4				
Location	L.A.				
Recorded By	LAPORTE				
Witnessed By	R. COOK				
Perforation Record		Perforation Record			
Type	Slot Size	From	To	Type	
Louvers	N/A	1004'	2280'	2"	
				Slot Size	
				PVC	
				From	
				0	
				To	
				999'	
Casing Record		Size			
Surface String		Wgt/Ft			
Camera Tube		Top			
Production String		Bottom			
Liner		14"			
		CSG			
		0			
		2300'			
<<< Fold Here >>>					
All interpretations are opinions based on inferences from electrical or other measurements and Pacific Surveys cannot and do not guarantee the accuracy or correctness of any interpretation, and we shall not, except in the case of gross or willful negligence on our part, be liable or responsible for any loss, costs, damages, or expenses incurred or sustained by anyone resulting from any interpretation made by any of our officers, agents or employees. These interpretations are also subject to Pacific Surveys' general terms and conditions set out in our current Price Schedule.					
Comments					
Database File: 13801.db Dataset Pathname: Layne/LosAlamo/turn1/13801fld Presentation Format: spin Dataset Creation: Sun May 11 10:54:04 2008 Charted by: Depth in Feet scaled 1:240					

Figure J-2.0-4 Estimated fluid velocity

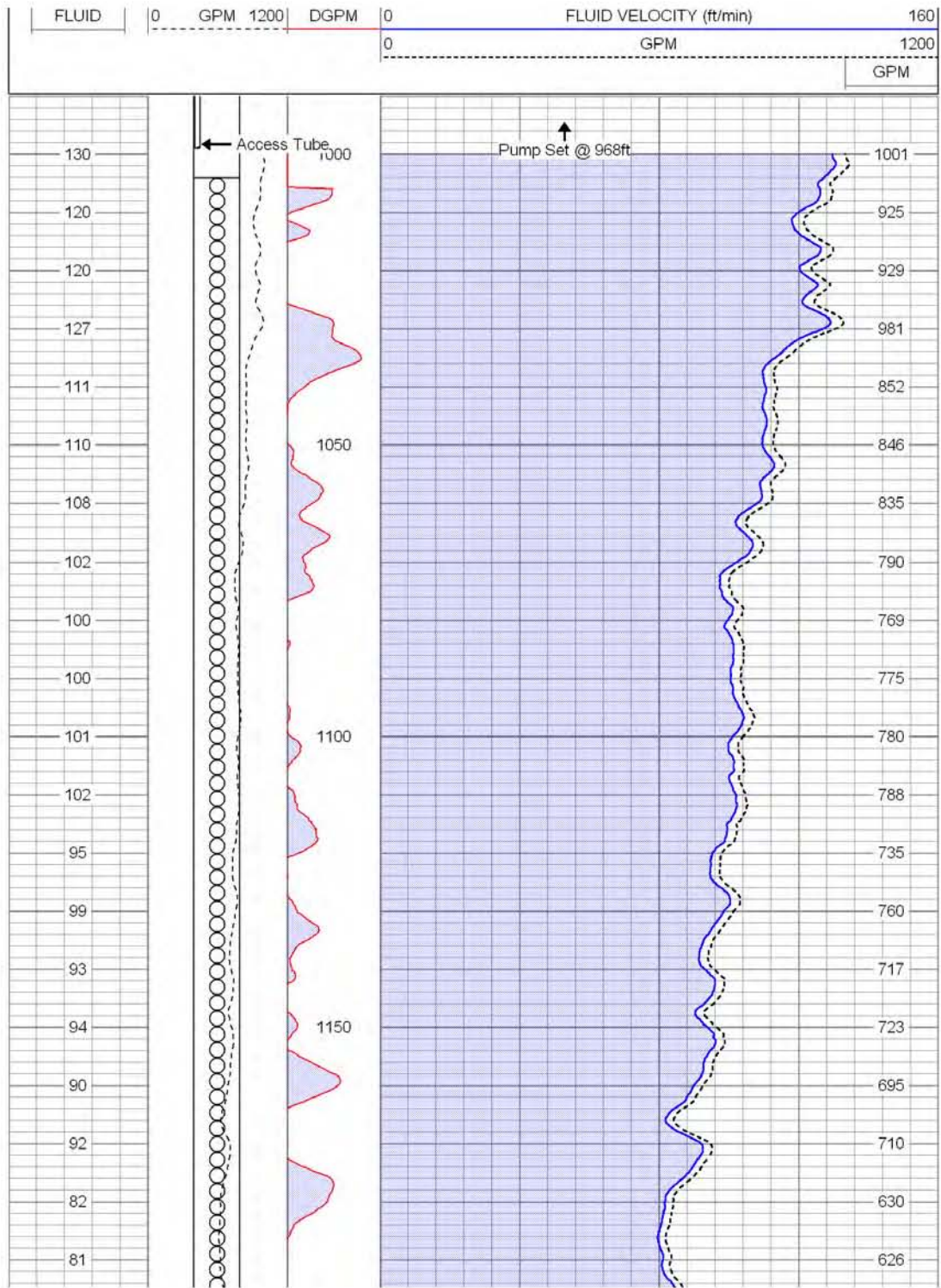

Figure J-2.0-4 (continued)

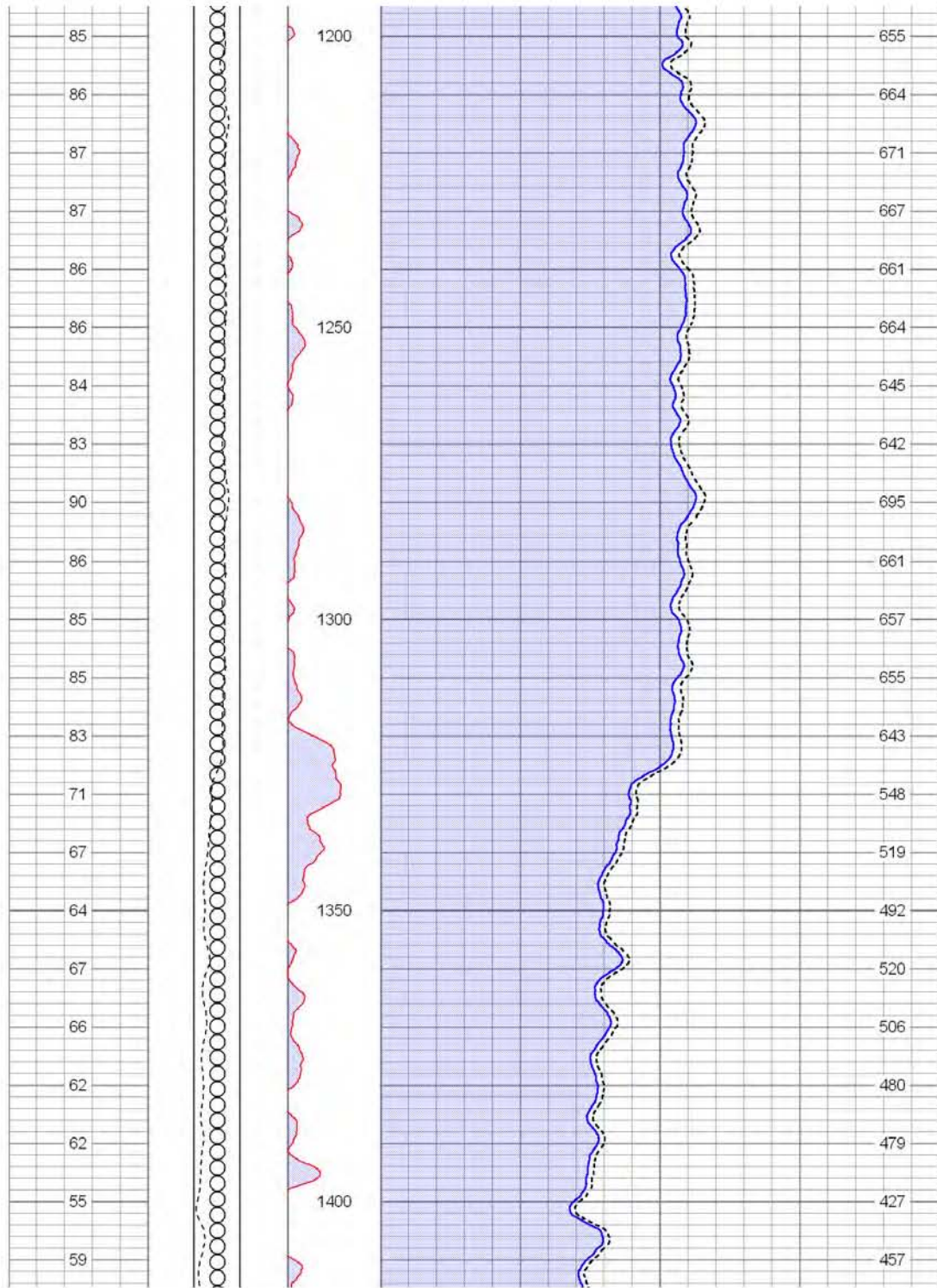

Figure J-2.0-4 (continued)

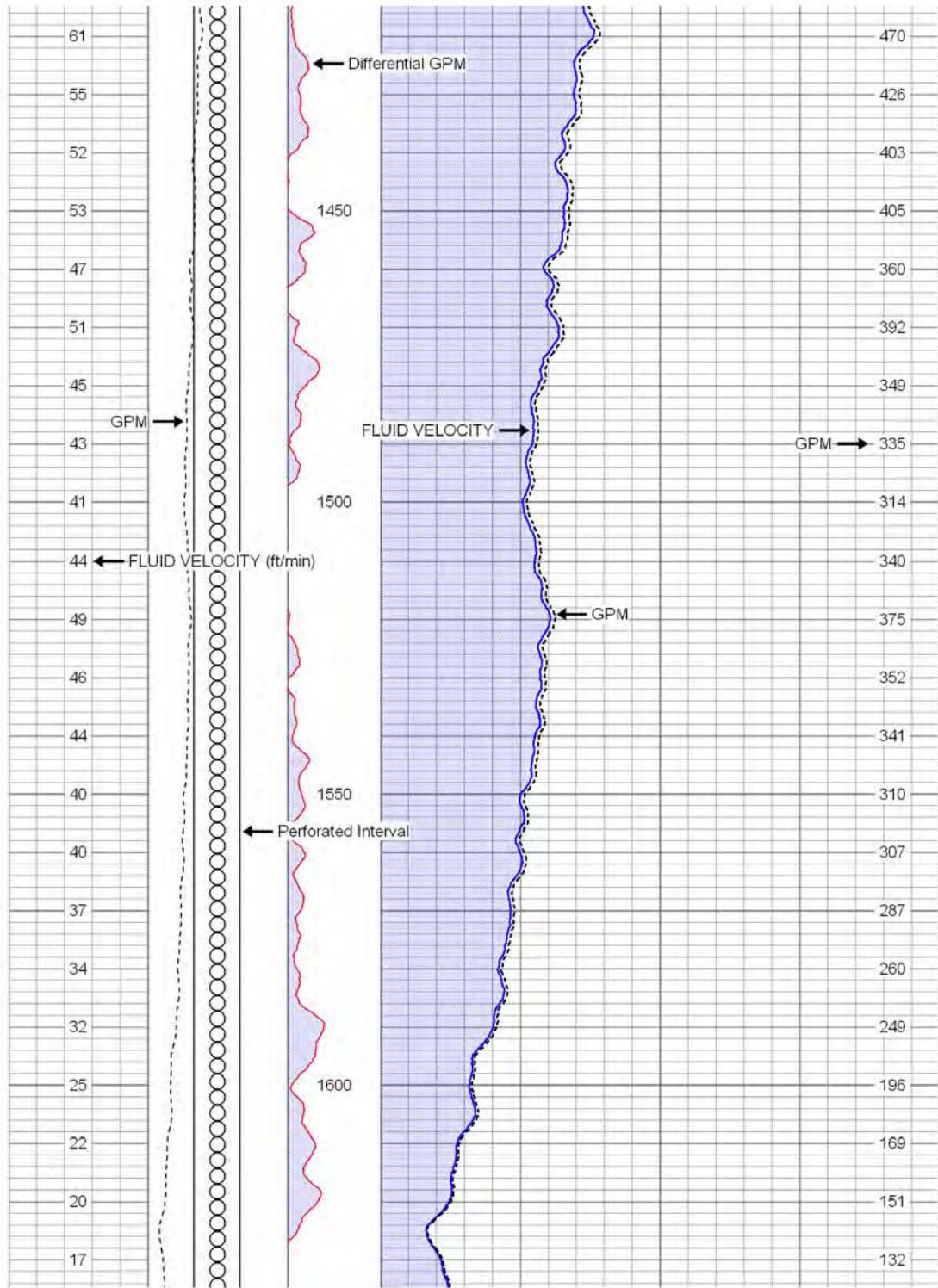

Figure J-2.0-4 (continued)

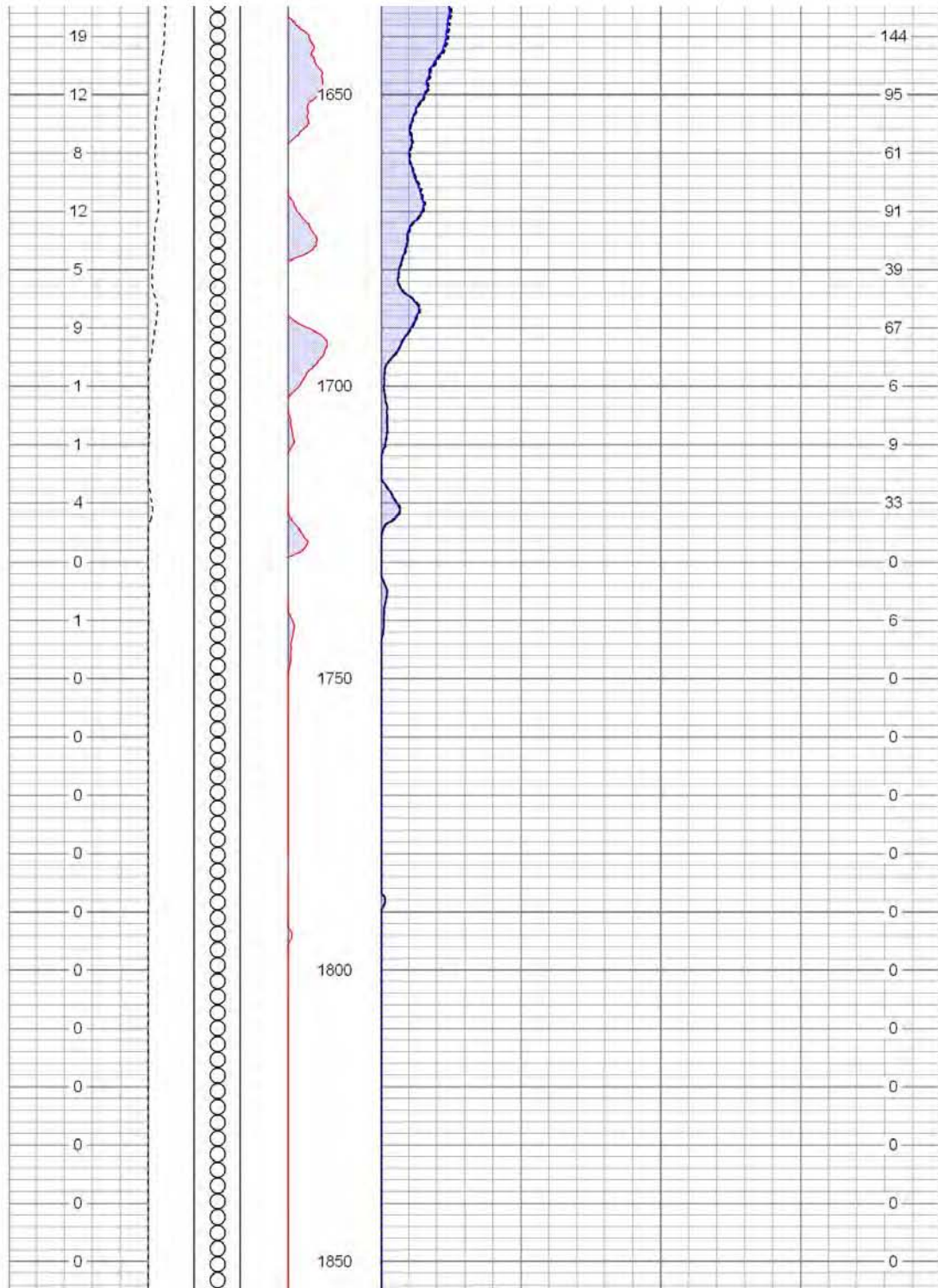

Figure J-2.0-4 (continued)

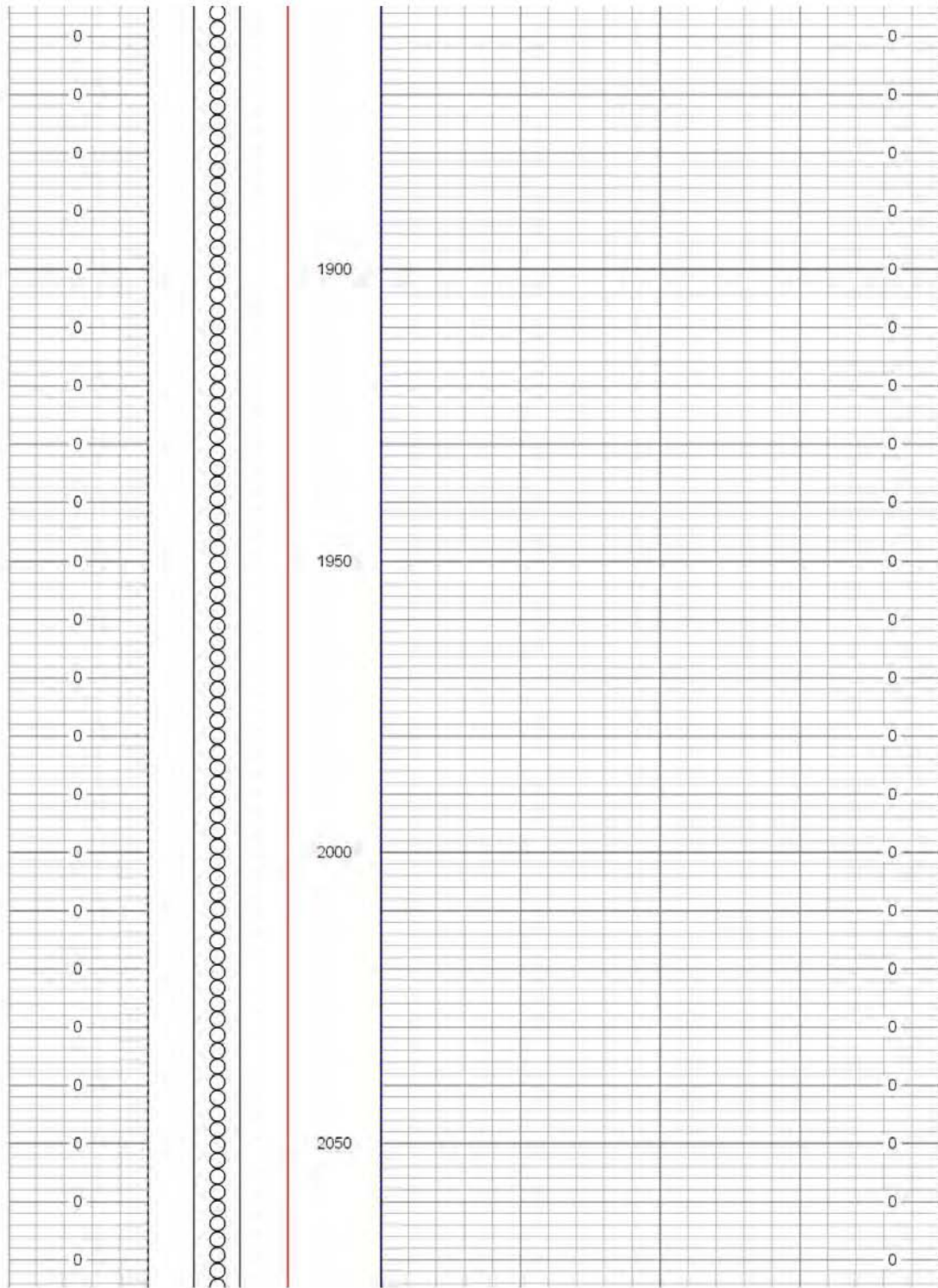

Figure J-2.0-4 (continued)

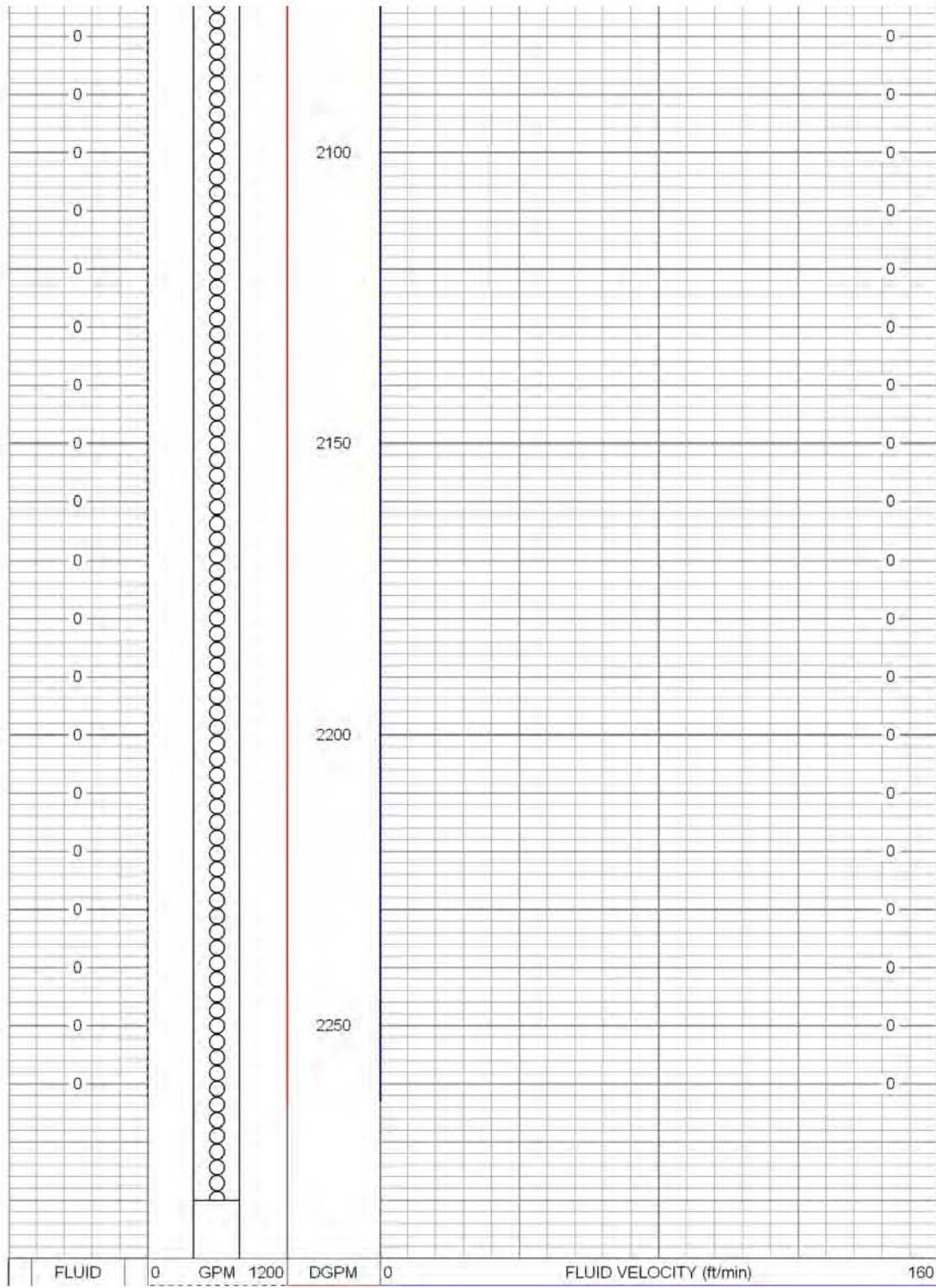
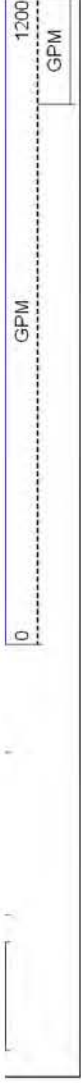

Figure J-2.0-4 (continued)



SPINNER LOG ANALYSIS					Pacific Surveys
MAX FLOW RATE					1008.63 GPM
PERFS DEPTHS	PRODUCTION GPM	% OF FLOW ZONES	GPM/FT	THICKNESS ft	
1004-1100	218.61	22%	2.28	96	
1100-1300	119.32	12%	0.60	200	
1300-1500	295.38	29%	1.48	200	
1500-1700	333.97	33%	1.67	200	
1700-1900	41.35	4%	0.21	200	
1900-2260	0.00	0%	0.00	360	

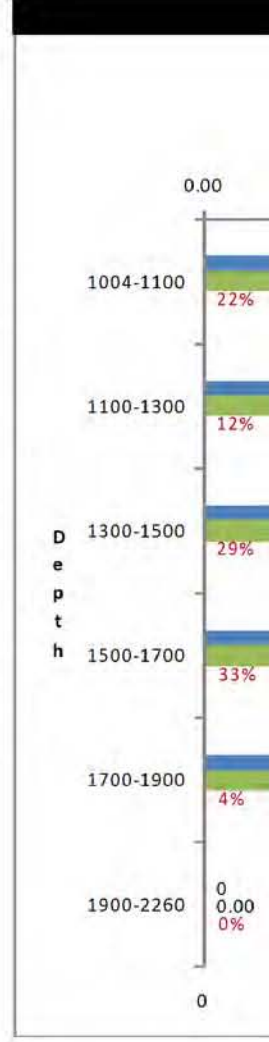

Figure J-2.0-4 (continued)

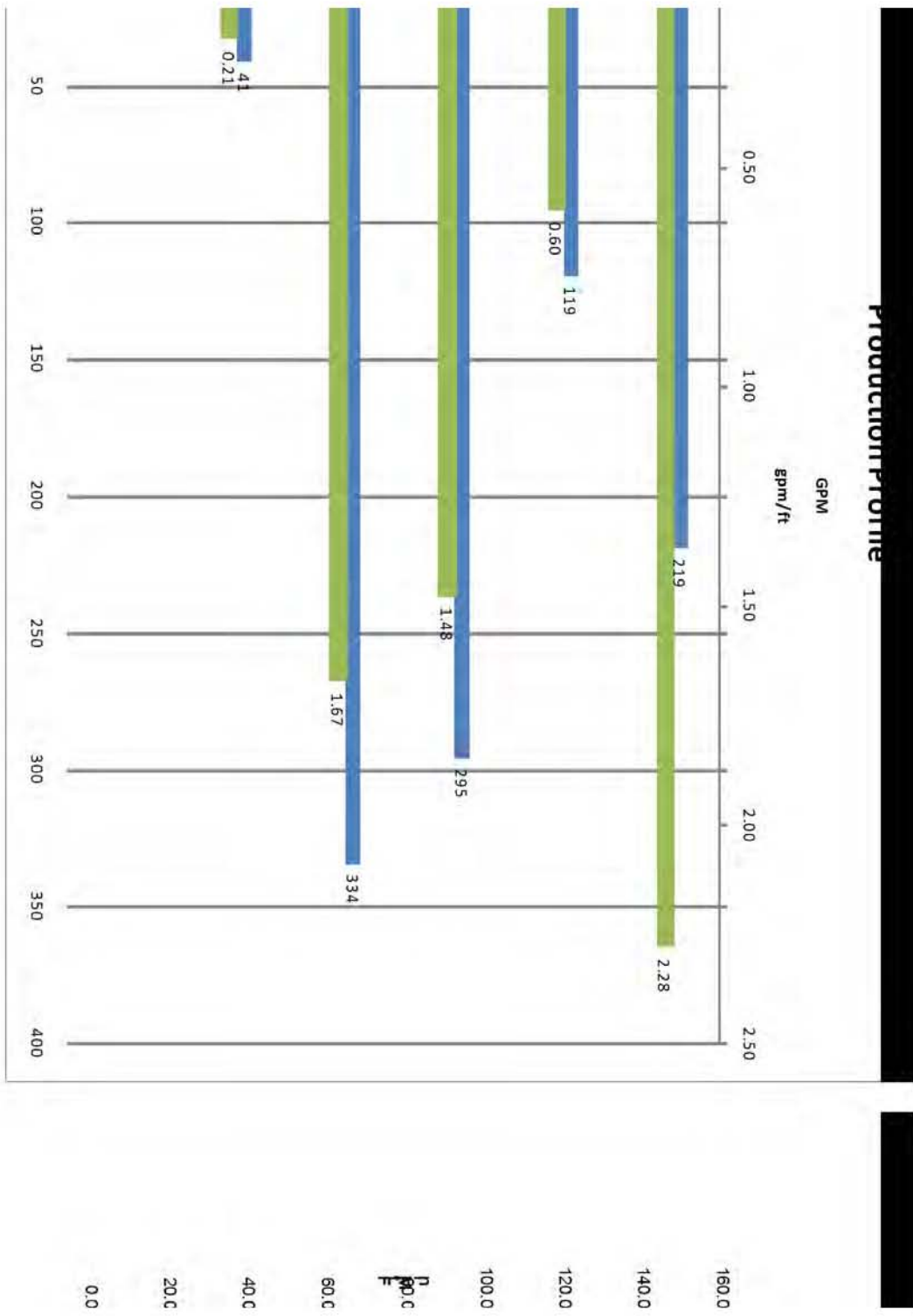

Figure J-2.0-4 (continued)

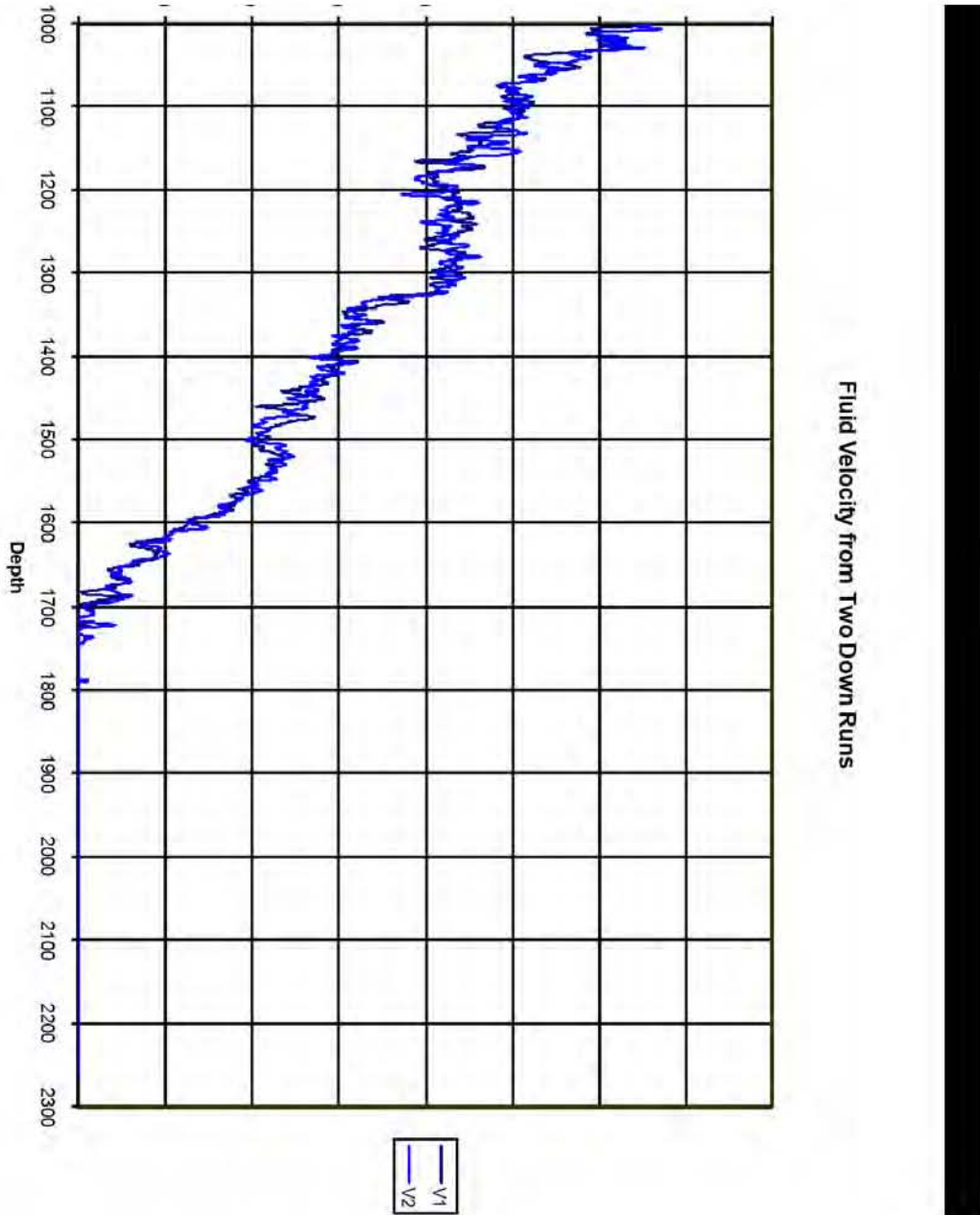

Figure J-2.0-4 (continued)

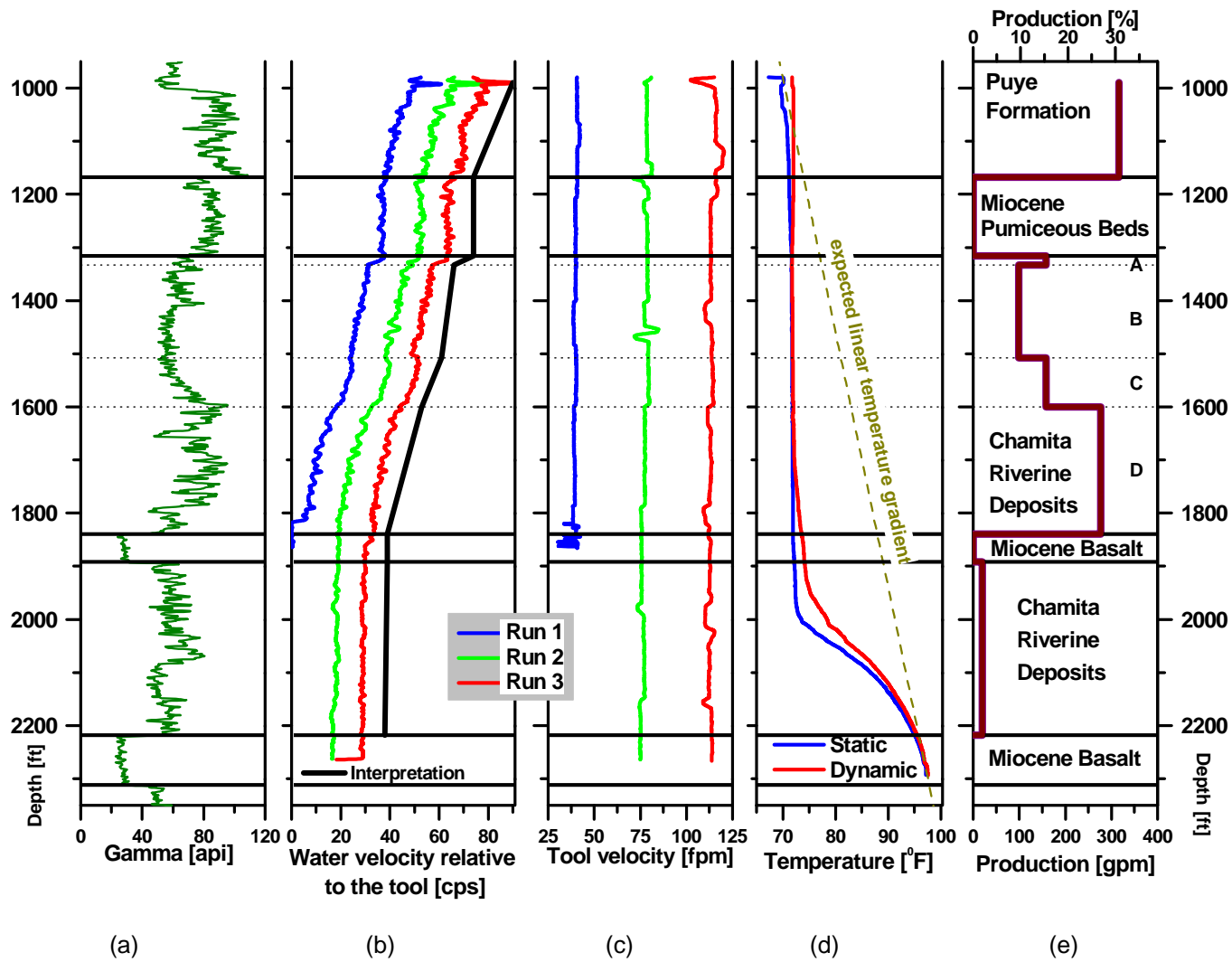

Figure J-2.0-5 Log data and analyses of log data collected at PM-2: (a) gamma log, (b) spinner log (cps = count [revolutions of the tool] per second), (c) tool velocity, (d) temperature log, and (e) production summary

**Table J-2.0-1
Summary of the Spinner Log Conducted in PM-2**

Unit	Subunit	Interval (ft bgs)			Velocity Change (cps)	% of Total Production	Production (gpm)	Production per Screen Length (gpm/ft)
		Top	Bottom	Length				
Puye Formation	n/a*	1004	1168	164	16	31%	317	1.93
Miocene Pumiceous Beds	n/a	1168	1316	148	0	0%	0	0.00
Chamita Formation Riverine Deposits	A	1316	1333	17	8	15%	158	9.29
	B	1333	1508	175	5	10%	99	0.57
	C	1508	1600	92	8	15%	158	1.72
	D	1600	1840	240	14	27%	277	1.15
Miocene Basalt	n/a	1840	1892	52	0	0%	0	0.00
Chamita Formation Riverine Deposits	n/a	1892	2218	326	1	2%	20	0.06

*n/a = Not applicable.

Appendix K

*Hydrogeological Information about Selected Springs in the
Pajarito Canyon Watershed*

K-1.0 UPPER PAJARITO CANYON SPRINGS

A group of springs discharge to the floor of upper Pajarito Canyon and two of its tributaries, south fork of Pajarito Canyon (“Starmer Gulch”) and north Anchor East basin (“Arroyo de la Delfe”), in the vicinity of Technical Area 09 (TA-09) and TA-22 (Figure K-1.0-1). These springs cluster within an area of 0.24 km² and are the source of perennial surface-water flow that extends about 2 km downcanyon. Table K-1.0-1 summarizes the characteristics and locations of these springs.

All of the springs issue between elevations of 2259 and 2276 m (7412 and 7467 ft) within Tshirege Member unit Qbt 3t. Qbt 3t appears to be an important perching horizon for other canyons in the western part of Los Alamos National Laboratory (the Laboratory) as well. For example, Hanlon and Anderson Springs in Twomile Canyon (elevations 2263–2281 m [7423–7482 ft]), Peter Canyon, sanitary wastewater system, and Burning Ground Springs in Cañon de Valle (elevations 2261–2268 m [7417–7440 ft]) discharge at about the same elevations and issue from the same geologic unit as those in upper Pajarito Canyon.

Qbt 3t is a stack of strongly welded ignimbrites that were deposited over the western part of the Pajarito Plateau (Lewis et al. 2002, 073785). This unit is 0–20 m thick, and it pinches out a short distance east of the north Anchor East basin/Pajarito Canyon confluence. The “t” in the name Qbt 3t refers to the transitional nature of this unit, which has chemical and petrographic characteristics that fill compositional gaps between the more widespread units of Qbt 4 above and Qbt 3 below. Qbt 3t becomes progressively thicker westward toward the Pajarito fault zone.

Groundwater pathways within Qbt 3t are likely associated with horizontal bedding features between individual ignimbrites and vertical structural features, such as fractures and joints. Because Qbt 3t is commonly moderately to densely welded from top to bottom, the massive interiors of individual ignimbrite deposits have low porosities and probably behave as aquitards. The boundaries between these individual ignimbrites are commonly separated by partings (horizontal fractures) that locally grade laterally into and out of sandy pyroclastic surge deposits. More extensive surge deposits occur at the unit contacts with overlying Qbt 4 and underlying Qbt 3. Although local variations are likely, the dips of partings and surge deposits within Qbt 3t are probably predominantly toward the east-southeast, similar to the dip of the unit as a whole. However, local dips in the vicinity of the upper Pajarito springs are controlled by a small north-trending syncline mapped by Lewis et al. (2002, 073785), with most springs located on the east-dipping limb of the syncline or near the syncline axis. Thus lateral movement of perched groundwater in Qbt 3t is probably controlled by a combination of horizontal fracture flow along partings and porous flow in sandy pyroclastic surge deposits, with flow generally toward the east or east-southeast. The discharge points tend to be located where the partings and surge deposits intersect drainages incised into Qbt 3t. Diversion and vertical stair-stepping of perched zones probably occur along fractures and faults. Detailed mapping by Lewis et al. (2002, 073785) indicates that fault traces are short and have little displacement (<1.5 m [<5 ft]) in the area of the upper Pajarito springs (Figure K-1.0-1), and none of the spring discharge points appear to be directly related to faults.

Groundwater in Qbt 3t is probably recharged by infiltration of surface water and by deeper percolation of perched water along the Pajarito fault zone (Dale et al. 2005, 102785), particularly where crossed by large drainages. Qbt 3t underlies the floor of Pajarito Canyon between the Pajarito fault zone and the confluence with the south fork of Pajarito Canyon. Fractures and faults in these brittle tuffs near the fault zone and along related tectonic structures to the east provide vertical pathways for recharging perched groundwater within Qbt 3t. In the vicinity of TA-09 and TA-22, local infiltration of surface water along fractures and faults is an additional minor source of recharge but is probably responsible for the detection

of Laboratory contaminants, such as tritium, perchlorate, RDX, and/or nitrate at Bulldog, Charlie's, Homestead, Kieling, and Starmer Springs.

The flow rate of the springs estimated by Dale et al. (2005, 102780) is listed in Table K-1.0-1. The total flow rate of all the springs ranges from 90 to 192 liters per minute (L/min). Flow rates for springs, inferred from the recessional limbs of stream gages E242 and E242.5 hydrographs (Appendix L), are seasonally variable, indicating enhanced recharge of the perched zone during snow-melting and monsoon seasons.

K.2.0 SPRINGS IN THREEMILE CANYON

Threemile Canyon and TA-18 Springs discharge to the floor of Threemile Canyon west of TA-18 (Figure K-2.0-1). These springs are probably the source of intermittent surface water that flows past gage E246 near the western TA-18 boundary in Threemile Canyon (Figure 7.2-1.). Discharge rates range from 0 to 29 L/min at Threemile Spring and from 6 to 22 L/min at TA-18 Springs (Dale et al. 2005, 102780).

Threemile Spring discharges from the active stream channel at an elevation of 2087 m [6846 ft]. There is uncertainty about the source of water at the spring. Because the spring is located in the active channel, it might represent alluvial groundwater that daylights in the active channel. However, the small size of the Threemile drainage basin makes it unlikely that snow melt and storm runoff is sufficient to support a long-lived alluvial groundwater system. Therefore, it is likely that the spring (and the alluvial groundwater in the canyon, particularly farther to the east) is probably recharged by perched groundwater from bedrock sources.

Unit Qbt 1vc (lower colonnade part of Qbt 1v) of the Tshirege Member of the Bandelier Tuff underlies thin alluvial deposits on the floor of Threemile Canyon in the vicinity of Threemile Spring, and it is the suballuvial bedrock unit as far east as alluvial well 3MAO-2 (Figure K-2.0-1). Where exposed in nearby outcrops, Qbt 1vc is a resistant tuff that has characteristic fracture-bound vertical columns that distinguish it from sparsely fractured units Qbt 1vu above and Qbt 1g below. Although typically nonwelded, Qbt 1vc is strongly consolidated and forms a prominent cliff between the softer tuffs above and below. Qbt 1vc is 5 to 10 m thick in the vicinity of Threemile Canyon. It contains few horizontal bedding features to act as lateral pathways for flow of perched groundwater. Thus the network of interconnected vertical fractures forms the likely groundwater pathway. Most of the fractures terminate near the bottom of the unit, favoring lateral flow rather than drainage to deeper units. Although the source of recharge for Threemile Spring is not well understood, the east-southeast dip of Tshirege tuffs suggests that surface water may infiltrate Qbt 1vc where it subcrops alluvium in Pajarito Canyon near the Twomile Canyon confluence. The perched groundwater in the recharge zone beneath Pajarito Canyon could then flow through fractures in Qbt 1vc toward the east-southeast before the unit intersects the incised channel in Threemile Canyon. Delayed response to precipitation events at stream gage E246 (Appendix L) supports the conceptual model that a significant portion of the surface and alluvial water in Threemile Canyon is derived from bedrock springs, possibly recharged by infiltration beneath Pajarito Canyon.

TA-18 spring discharges from a buried pipe on the north slope of Threemile Canyon. A geophysical survey traced the pipe 150 m (496.9 ft) upcanyon to a cistern constructed in canyon floor alluvium (Figure K-2.0-1). Water-level data from nearby alluvial wells 18-BG-4 and 18-MW-18 indicate that this part of Threemile Canyon supports an alluvial groundwater system most times of the year. Therefore, the "TA-18 Spring" probably represents alluvial groundwater rather than a discrete spring discharge point. However, the alluvial system is probably recharged by Threemile Spring and possibly by other locations beneath the canyon floor where perched groundwater enters alluvium from buried Qbt 1vc bedrock (Figure K-2.0-1).

The flow rate of the springs estimated by Dale et al. (2005, 102780) is listed in Table K-2.0-1. The total flow rate of the two springs in Threemile Canyon ranges from 6 to 51 L/min. The flow rate at stream gage E246 is seasonally variable, indicating enhanced recharge of the perched zone during snow-melting and monsoon seasons.

K-3.0 4-SERIES SPRINGS

A group of springs referred as the “4-series springs” discharge in and near lower Pajarito Canyon where the drainage descends the west side of White Rock Canyon. These springs cluster within an area of 0.4 km², and some of these are the source of perennial surface water that flows about 0.8 km to the Rio Grande. Six of these springs have been named and sampled. Table K-3.0-1 summarizes the characteristics, locations, and flow rates of these springs.

The springs can be divided into two groups, based on their discharge elevation and location. Springs 4A and 4AA issue between elevations of 1712 and 1717 m (5617 and 5634 ft) and drain into the main channel of Pajarito Canyon, supporting the perennial flow in the lower canyon. Springs 4, 4B, 4C, and 4D issue between elevations of 1651 and 1678 m (5416 and 5506 ft) closer to the Rio Grande but away from the Pajarito Canyon channel (Figure K-3.0-1). All of the springs are discharged within a massive landslide complex that covers the slopes of White Rock Canyon.

The landslide complex consists mostly of large slumps or “Toreva-block” slides made up of coherent masses of basalt caprock and underlying sediments detached from the canyon wall that descended along curved fault planes before coming to rest as back-tilted blocks on the lower slopes of the canyon (Reneau et al. 1995, 054405; Reneau and McDonald 1996, 055538). The landslide complex in the vicinity of the Pajarito drainage is over 0.65 km wide (2153 ft) and consists of overlapping Toreva blocks (Figure-K-3.0-1). Individual Toreva blocks are as much as 0.7 km (2319 ft) long parallel to the canyon wall and 0.3 km (994 ft) wide. Failure planes are rarely exposed, but the lower parts are probably mainly within the sedimentary rocks of the Santa Fe Group (Figure K-3.0-1). Troughs and depressions formed behind individual slump blocks are typically filled with relatively fine-grained slopewash and eolian deposits (Reneau et al. 1995, 054405). Other deposits associated with the landslide complex include small-scale rock falls and rocky colluvium, alluvium in the stream channel, and lacustrine deposits near the Rio Grande (Reneau et al. 1995, 054405; Reneau and McDonald 1996, 055538).

Groundwater pathways within the landslide deposits are likely to be complex because of heterogeneous lithologies of the displaced rock masses, ranging from massive basalt to porous sedimentary deposits. Superimposed on the diverse lithologies are numerous structural features, such as low-angle detachment faults, faults internal to individual slump blocks, cooling and slide-induced fractures in the basalts, and rubblized rock masses. Primary bedding in the sedimentary units and interflow breccias in the basalts dip westward because of the rotation of the Toreva blocks during their emplacement.

Springs 4A and 4AA discharge within the Pajarito drainage at an elevation below the regional water table based on water levels observed in nearby monitoring wells. The elevation of the regional water table in well R-16r, located 2.7 km (8944 ft) to the north-northeast, is about 1735 m (5693 ft), or about 18 to 23 m (59 to 76 ft) higher than the springs. The elevation of the regional water table is similar in well R-23 (1737 m [5698 ft]), located about 3 km (99337 ft) to the east-northeast. In addition, the water chemistry and temperature of Springs 4A and 4AA are similar to regional groundwater in the area. Groundwater temperatures measured at the source of the two springs range from 18.3°C to 21.1°C, with temperatures slightly higher at Spring 4A (from 19.6°C to 21.1°C) (Longmire et al. 2007, 096660). Major ion chemistries are very similar at both springs, suggesting that they are closely related in terms of geochemical processes controlling their composition (Ca-Na-HCO₃ type water). Springs 4A and 4AA also contain

elevated above-background concentrations of nitrate(N) (0.84 to 1.21 ppm) (Longmire et al. 2007, 096660). Contaminants observed at the 4-series springs are discussed in more detail in Section 7.2.2.2 of this report. Together, the discharge elevations and water chemistry of the springs suggest that Springs 4A and 4AA are fed by regional groundwater derived from the regional aquifer in the undisturbed hydrostratigraphic units under the Pajarito Plateau. The presence of elevated nitrate indicates there is a component of recharge that includes pathways from Laboratory release sites. The similar elevations of the water table at the two regional wells R-23 and R-16r suggest that the groundwater flow in the regional aquifer may be perpendicular to the line connecting the wells. As a result, the groundwater flow in the regional aquifer is expected to have a dominant southeastern component. Contours of the regional water-table elevations presented in Figure K-3.0-1 are extrapolated from regional water-level maps and take into account the discharge elevations of some of the White Rock Canyon springs. Nonetheless, the water-table contours near the Rio Grande are uncertain because of the lack of additional wells or control points between R-16r and R-23. Based on the water-table map, the regional groundwater discharged at the springs could originate to the north of the Pajarito Canyon watershed. Groundwater from the regional aquifer moves downgradient into the landslide complex before daylighting in the Pajarito drainage.

Springs 4, 4B, 4C, and 4D discharge on the east side of the landslide complex near the Rio Grande. Although these springs also discharge at lower elevations than those of the regional water table west of the Rio Grande, their water chemistry and temperature more closely resemble perched intermediate groundwater that occurs beneath the Pajarito Plateau (Longmire et al. 2007, 096660). Concentrations of nitrate, nitrate plus nitrite, chloride, perchlorate, and/or tritium are higher at Springs 4, 4B, and 4C than at Springs 4A and 4AA. In addition, waters from these springs are 2980 to 4360 yr younger than Springs 4A and 4AA (Longmire et al. 2007, 096660). These results are consistent with the interpretation that these springs represent regional groundwater mixed with a greater proportion of young recharge than at Springs 4A and 4AA. Components of the young recharge could include surface water from the Pajarito Canyon watershed and/or perched intermediate groundwater beneath the plateau. Some of the young recharge may be in the form of snowmelt and storm runoff that collects in the depressions formed behind individual slump blocks that infiltrates the slide complex and mingles with groundwater before discharging at the springs.

K-4.0 REFERENCES

The following list includes all documents cited in this appendix. Parenthetical information following each reference provides the author(s), publication date, and ER ID number. This information is also included in text citations. ER ID numbers are assigned by the Environmental Programs Directorate's Records Processing Facility (RPF) and are used to locate the document at the RPF and, where applicable, in the master reference set.

Copies of the master reference set are maintained at the NMED Hazardous Waste Bureau; the U.S. Department of Energy—Los Alamos Site Office; the U.S. Environmental Protection Agency, Region 6; and the Directorate. The set was developed to ensure that the administrative authority has all material needed to review this document, and it is updated with every document submitted to the administrative authority. Documents previously submitted to the administrative authority are not included.

Dale, M.R., F. Goff, K. Granzow, P. Longmire, and D. Counce, October 16–19, 2005. "Assessing Groundwater Recharge through the Pajarito Fault Zone, Upper Pajarito Canyon, Los Alamos, New Mexico," poster presented at the Annual Meeting of the Geological Society, October 16–19, 2005, Salt Lake City, Utah. (Dale et al. 2005, 102785)

- Dale, M.R., K. Granzow, D. Englert, S. Yanicak, R. Ford-Schmid, P. Longmire, and D. Counce, April 15, 2005. "An Update on the Surficial Water Resources in the Los Alamos Area, New Mexico," poster presented at the New Mexico Geological Society Annual Spring Meeting, April 15, 2005, Socorro, New Mexico. (Dale et al. 2005, 102780)
- Lewis, C.J., A. Lavine, S.L. Reneau, J.N. Gardner, R. Channell, and C.W. Criswell, December 2002. "Geology of the Western Part of Los Alamos National Laboratory (TA-3 to TA-16), Rio Grande Rift, New Mexico," Los Alamos National Laboratory report LA-13960-MS, Los Alamos, New Mexico. (Lewis et al. 2002, 073785)
- Longmire, P., M. Dale, D. Counce, A. Manning, T. Larson, K. Granzow, R. Gray, and B. Newman, July 2007. "Radiogenic and Stable Isotope and Hydrogeochemical Investigation of Groundwater, Pajarito Plateau and Surrounding Areas, New Mexico," Los Alamos National Laboratory report LA-14333, Los Alamos, New Mexico. (Longmire et al. 2007, 096660)
- Reneau, S.L., D.P. Dethier, and J.S. Carney, 1995. "Landslides and Other Mass Movements near Technical Area 33, Los Alamos National Laboratory," Los Alamos National Laboratory report LA-12955-MS, Los Alamos, New Mexico. (Reneau et al. 1995, 054405)
- Reneau, S.L., and E.V. McDonald, LA-UR-96-3035. "Landscape History and Processes on the Pajarito Plateau, Northern New Mexico," in *Friends of the Pleistocene Field Trip Guidebook*, Rocky Mountain Cell, Los Alamos National Laboratory document LA-UR-96-3035, Los Alamos, New Mexico. (Reneau and McDonald 1996, 055538)

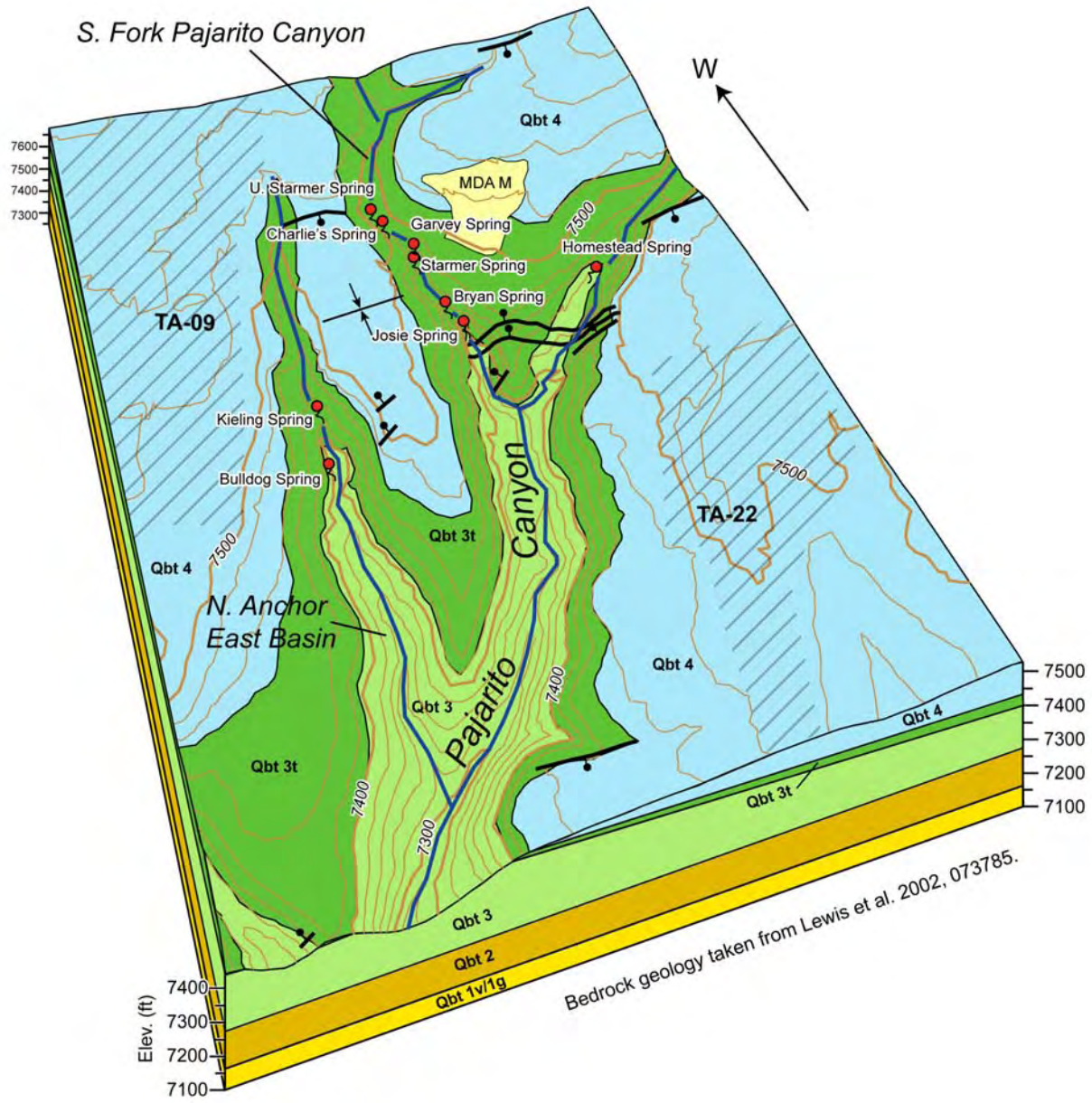

Figure K-1.0-1 Hydrogeologic block diagram showing the relationship between spring discharge points in upper Pajarito Canyon and bedrock geology

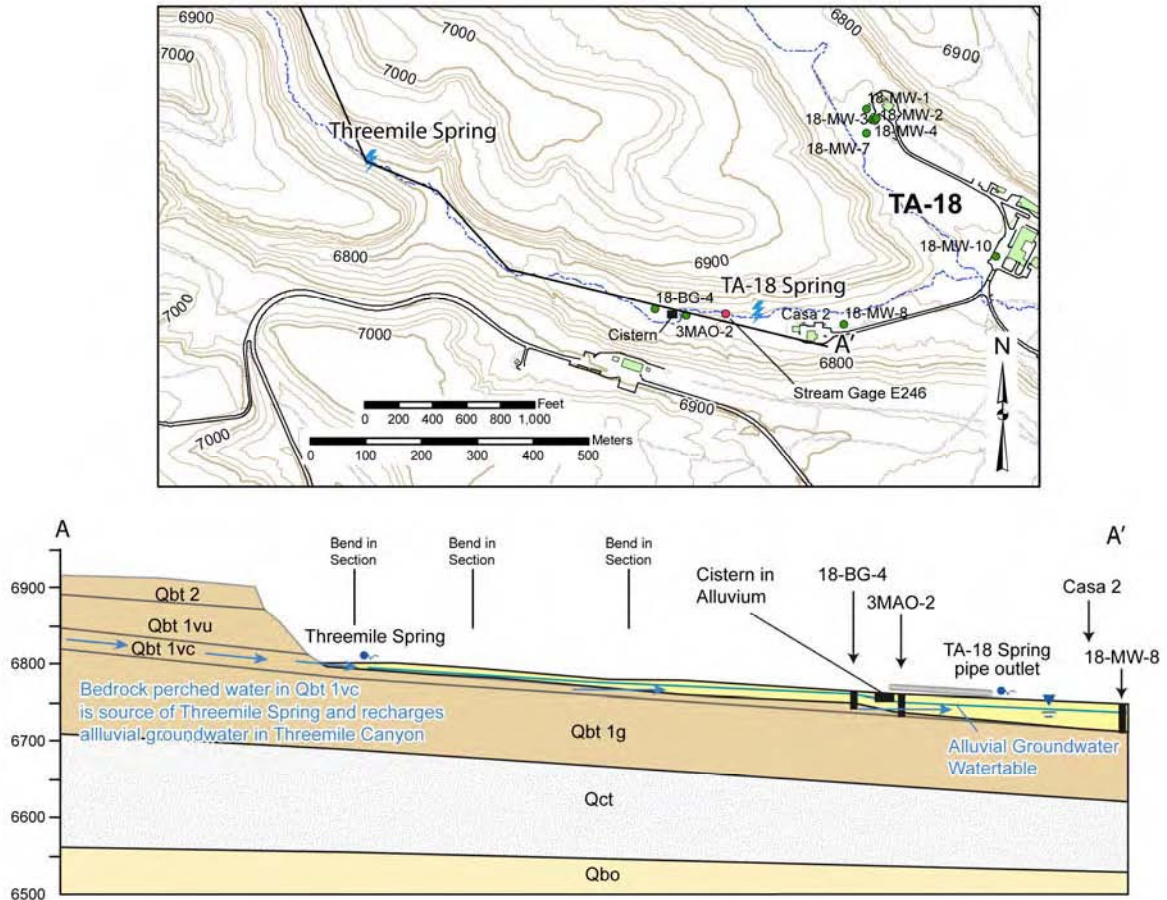

Figure K-2.0-1 Conceptual geologic cross section showing the relationship between spring discharge points in Threemile Canyon and bedrock geology

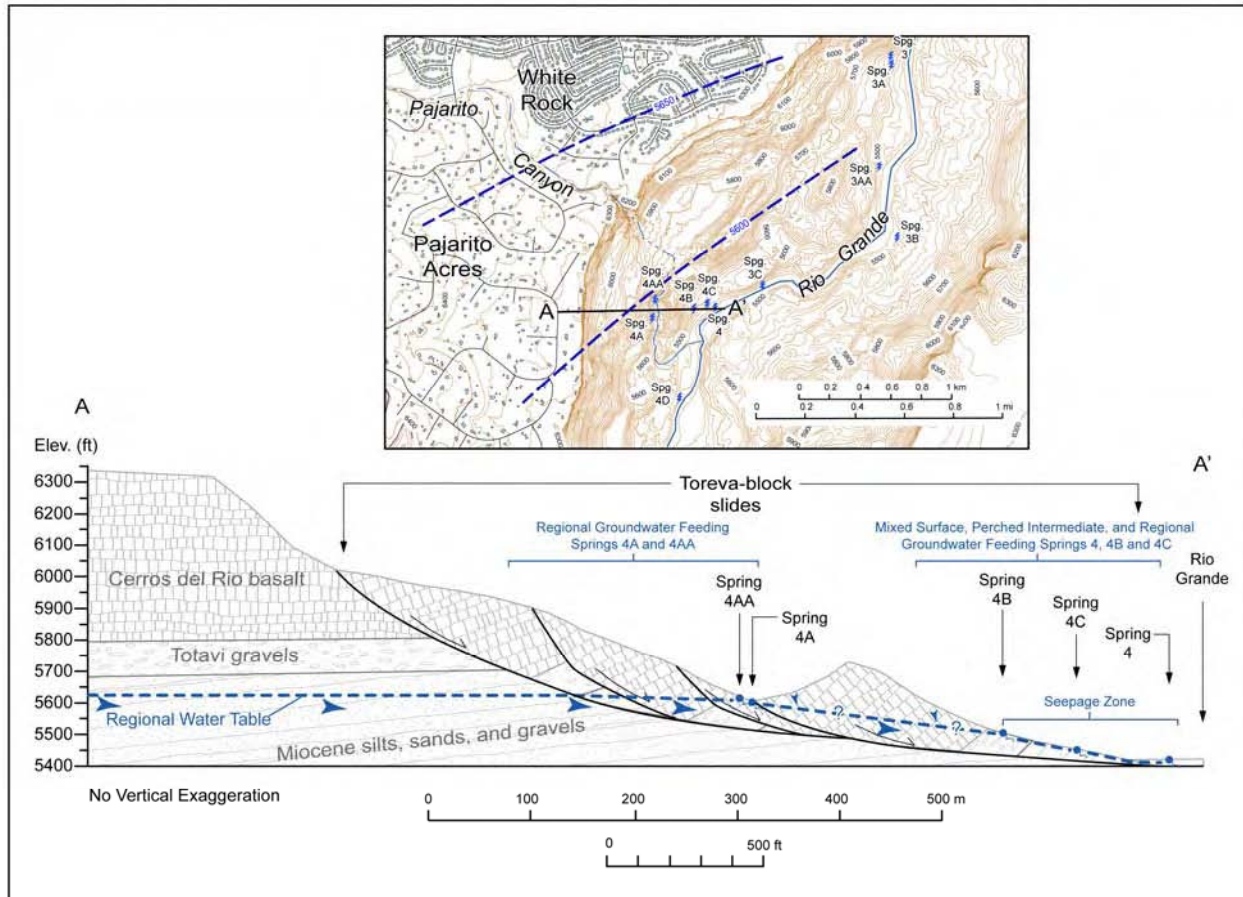

Figure K-3.0-1 Map and east-west conceptual geologic cross section of the 4-series springs in White Rock Canyon. Regional water table contours shown as blue dashed lines in map view.

Table K-1.0-1
Hydrogeologic Characteristics of the Upper Pajarito Springs

Name	Elevation (m) with (ft) in brackets	Location	Estimated Flow (L/min) ^a	Comments ^b
Homestead Spring	2268 [7440]	Pajarito Canyon	10–30	Contact between Qbt 3t and Qbt 3; discharges from south slope of canyon about 1 m above active channel.
Upper Starmers Spring	2276 [7467]	South Fork Pajarito Canyon	0–15	Qal over middle of Qbt 3t; discharges from active channel.
Charlie's Spring	2273 [7456]	South Fork Pajarito Canyon	4–5	Middle of Qbt 3t; Discharges from north slope of canyon about 1 m above active channel.
Perkins Spring	2270 [7446]	South Fork Pajarito Canyon	0–4	Middle of Qbt 3t; discharges from north slope of canyon about 1 m above active channel.
Garvey Spring	2271 [7451]	South Fork Pajarito Canyon	<2	Middle of Qbt 3t; discharges from south wall of canyon about 1 m above active channel.
Starmer Spring	2270 [7447]	South Fork Pajarito Canyon	20–50	Middle of Qbt 3t; discharges from south wall of canyon about 0.5 m above active channel.
Bryan Spring	2259 [7412]	South Fork Pajarito Canyon	8–12	Qal over lower part of Qbt 3t; discharges from active channel/bank.
Josie Spring	2259 [7412]	South Fork Pajarito Canyon	0–4	Lower part of Qbt 3t; discharges from north wall of canyon about 12 m above active channel.
Kieling Spring	2261 [7418]	North Anchor East Basin	8–20	Lower part of Qbt 3t; discharges from north and south slopes of canyon about 1 m above active channel.
Bulldog Spring	2254 [7395]	North Anchor East Basin	40–50	Contact between Qbt 3t and Qbt 3; discharges from south slope of canyon about 3 m above active channel.
Total Flow Rate:			90–192	

^a Estimated discharge rates from Dale et al. (2005, 102780).

^b Descriptions of discharge physical settings from Dale et al. (2005, 102780).

Table K-2.-0.1
Hydrogeologic Characteristics of the Threemile Canyon Springs

Name	Elevation (m) with (ft) in brackets	Location	Estimated Flow (L/min) ^a	Comments ^b
Threemile Spring	2087 [6846]	Threemile Canyon	0–29	Discharges from active channel/bank; flow measured by U.S. Department of Energy (DOE) Oversight Bureau
TA-18 Spring	2062 [6764]	Threemile Canyon	6–22	Discharges from a pipe on the north slope of the canyon about 2 m above the active channel; flow measured by DOE Oversight Bureau.
Total Flow Rate:			6–51	

^a Estimated discharge rates from Dale et al. (2005, 102780).

^b Descriptions of discharge physical settings from Dale et al. (2005, 102780).

Table K-3.0-1
Hydrogeologic Characteristics of the 4-Series Springs

Name	Elevation (m) with (ft) in brackets	Location	Estimated Flow (L/min) ^a	Comments ^b
4AA	1717 [5634]	Pajarito Canyon	10–20	Discharges from west slope of drainage about 2 m above active channel
4A	1712 [5617]	Pajarito Canyon	924	Discharges from west slope of drainage at several locations; highest discharge point is about 15 m above active channel; flow measured by DOE Oversight Bureau
4B	1709 [5506]	East side of landslide complex, next to river	10	Discharges along slope at several locations; highest discharge point is about 27 m above the river
4C	1665 [5464]	East side of landslide complex, next to river	80	Discharges along slope about 14 m above the river
4	1654 [5427]	East side of landslide complex, next to river	184	Discharges next to river; flow measured by DOE Oversight Bureau
4D	1651 [5416]	East side of landslide complex, 0.4 km south of the mouth of Pajarito Canyon	<2	Discharges next to river
Total Flow Rate:			~1210	

^a Estimated discharge rates from Dale et al. (2005, 102780).

^b Descriptions of discharge physical settings from Dale et al. (2005, 102780).

Appendix L

Analysis of Stream Flow and Alluvial Water Levels

L-1.0 PAJARITO CANYON STREAM CHARACTERISTICS

Pajarito Canyon contains an interrupted stream fed by several perennial springs in the upper portion of the canyon. Perennial flow from PC Spring in the upper reaches of the canyon is followed by an intermittent reach that extends to approximately 0.8 km (0.5 mi) west of Los Alamos National Laboratory (Laboratory) boundary (Plate 1). Pajarito Canyon then has an ephemeral reach extending downstream to a point approximately 1.6 km (1 mi) east of the western Laboratory boundary. At this point, Homestead Spring supports another perennial reach for approximately 1 mi (1.6 km), followed by an intermittent and/or ephemeral reach that at times may extend as far as the confluence with Threemile Canyon.

Both Twomile Canyon and Threemile Canyon contain ephemeral and/or intermittent streams. Seasonal springs in Twomile Canyon and perennial springs in Threemile Canyon support short reaches of ephemeral and perennial flow, respectively. East of the confluence with Threemile Canyon, Pajarito Canyon is ephemeral across Laboratory property to a point approximately 0.64 km (0.4 mi) upstream from the confluence with the Rio Grande. The 4-series springs in White Rock Canyon (Springs 4A and 4AA) are located at this point and support perennial flow to the confluence with the Rio Grande. In some years, snowmelt runoff extends onto Laboratory property downstream to near the confluence with Threemile Canyon. Local storm runoff from seasonal rainstorms occasionally extends downstream as far as the Rio Grande.

The south fork of Pajarito Canyon, the lower portion of which has been informally referred to as "Starmer Gulch," is a tributary to upper Pajarito Canyon at Technical Area 08 (TA-08) and TA-09 (see Plate 1). The south fork of Pajarito Canyon parallels Pajarito Canyon for approximately 3.8 km (2.4 mi) and has a drainage area of approximately 0.4 km² (0.15 mi²). Several springs discharge to the lower portion (Starmer Gulch), including Starmer, upper Starmer, Brian, Charlie's, Garvey, Josie, and Perkins. In this report, the informal name "Starmer Gulch" is used when relating previously printed information about this tributary. A diagram showing the location of the springs and a summary of spring discharges in upper Pajarito Canyon are presented in Appendix K.

A small tributary to the south fork of Pajarito Canyon drains most of TA-08, which is known as Anchor West Site. In this report, this small tributary to the south fork of Pajarito Canyon is referred to informally as "Anchor West basin."

A small tributary to Pajarito Canyon drains the northern portion of TA-09 (Anchor East Site). In this report, this small tributary is referred to informally as "north Anchor East basin" (Plate 1). The lower portion of Anchor East basin forms a small canyon that has previously been referred to informally as "Arroyo de la Delfe." The north Anchor East basin is approximately 1.3 km (0.8 mi) long. Bulldog Spring and Kieling Spring discharge into the lower portion of north Anchor East basin (Arroyo de la Delfe).

A small tributary to Pajarito Canyon drains the southern portion of TA-09 (Anchor East Site). This small tributary is informally referred to as "south Anchor East basin." This basin is approximately 0.6 km (1 mi) long and has a maximum width of approximately 450 m (1500 ft). This small tributary has not been formally named.

The Twomile Canyon drainage basin is north of Pajarito Canyon and parallels upper Pajarito Canyon for approximately 8 km (5 mi). Twomile Canyon heads on the flanks of the Sierra de los Valles at an elevation of approximately 2988 m (9800 ft), which is approximately 1.6 km (1 mi) east and 180 m (600 ft) lower than the head of adjacent Pajarito Canyon. Twomile Canyon joins Pajarito Canyon at TA-66 and contains a total area of 8.1 km² (3.13 mi²), comprising approximately 23% of the area of the Pajarito Canyon watershed.

Twomile Canyon consists of several tributaries, herein referred to as the north fork of Twomile Canyon, the main fork of Twomile Canyon, the southwest fork of Twomile Canyon, and the southeast fork of Twomile Canyon (see Plate 1). The north fork of Twomile Canyon is the largest tributary canyon (1.6 km² [0.62 mi²]); it forms the western border of TA-03 and is south of upper Los Alamos Canyon west of TA-03. Twomile Canyon also forms the south border of TA-59, TA-48, and TA-55. Springs located within the Twomile Canyon watershed include Anderson, Hanlon, SM-30, and TW 1.72 (Plate 1 and Figure 3.2-1).

After the Cerro Grande fire in 2000, a stormwater retention structure was constructed in middle Pajarito Canyon below the confluence with Twomile Canyon. The structure was designed to prevent flooding of TA-18 in case of high runoff from the upper part of the canyon by slowing down surface flow.

Threemile Canyon joins Pajarito Canyon at TA-18 and is the second largest tributary to Pajarito Canyon after Twomile Canyon. Threemile Canyon parallels Pajarito Canyon on the south and extends for a distance of approximately 5.28 km (3.3 mi). Threemile Canyon heads at TA-14 and includes portions of TA-67, TA-15, TA-36, and TA-18. Threemile Canyon has several unnamed tributaries; the largest is the south fork of Threemile Canyon, which has a total drainage area of approximately 4.3 km² (1.67 mi²) (Plate 1). Other tributaries to Threemile Canyon are informally referred to as the middle fork of Threemile Canyon and the west fork of Threemile Canyon. Springs that discharge to Threemile Canyon include Threemile Spring and TA-18 Spring.

L-2.0 STREAM FLOW CHARACTERISTICS IN PAJARITO CANYON

PC Spring is located in upper Pajarito Canyon on national forest land, approximately 2.6 km (1.6 mi) west (upstream) of the Laboratory boundary at an elevation of approximately 2640 m (8660 ft). The discharge from the spring is not gaged. On July 9, 1948, the spring flow volume was estimated to be 25 gpm from seeps issuing from a contact in volcanic rocks of the Tschicoma Formation to the alluvium and colluvium in the floor of the canyon (Stearns 1948, 011871, p. 11; John et al. 1966, 008796, p. 120). Griggs (1964, 092516, p. 91) reported that the spring “emerges from alluvium and talus in the floor of the canyon.” During a sampling event on May 22, 1991, the stream below the spring was reported to be flowing approximately 32 gpm (120 liters per minute [L/min]) (Blake et al. 1995, 049931, p. 8).

The spring supports perennial flow for a distance of about 1.6 km (1 mi), but flow does not typically extend to SR-501 and stream gage E240 near the eastern Laboratory boundary. The spring-fed flow infiltrates into thin alluvium and bedrock volcanic units along the Pajarito Fault zone. New Mexico Environment Department (NMED) personnel estimated the stream loss in the Pajarito fault zone to range from 114 to 134 L/min (30 to 35 gpm) (Dale et al. 2005, 102785). A spring-supported flow of 30 gpm (0.067 cfs [cubic foot per second]) is used to estimate the infiltration of surface water in upper Pajarito Canyon at the Pajarito Fault to be about 48 acre-ft/yr.

Stream flow and runoff in Pajarito Canyon and its tributaries are measured at the stream gages listed in Table L-2.0-1 and are shown in Figure 3.2-1. Stream-flow monitoring at gage E245.5 in Pajarito Canyon above Threemile Canyon was discontinued in April 2006. Gage E240 was located above SR-501 until it was damaged by flooding after the Cerro Grande fire, after which the gage was reconstructed below SR-501. Runoff and stream recovery associated with the Cerro Grande fire were summarized by Gallaher and Koch (2004, 088747). At both locations, this gage was downstream from the Pajarito Fault zone.

Figure L-2.0-1 summarizes the stream flow at each gage for the period from June 2005 to mid-2008. Each gage shows no flow at times, although for gages in perennial reaches, this results from freezing of the gage during winter months. The highest maximum flows for the period were observed in lower Twomile Canyon and middle Pajarito Canyon at gages E244, E245, and E245.5; the peak flows were in response to a summer thunderstorm runoff event on August 25, 2006. The highest average stream flows

are observed at E242 in Starmer Gulch where the stream is perennial from spring discharges. Peak flows at gage E240 below SR-501 and downstream E241 Pajarito above Starmer may be buffered by road culverts; flows in Starmer Gulch are often higher than in Pajarito Canyon.

Stream flow in upper Pajarito Canyon and local tributaries is shown in Figure L-2.0-2. This figure shows the mean daily discharge at gages E240, E241, E242, and E242.5 for the period from January 2006 to May 2008, and the daily precipitation recorded at the TA-06 meteorological station. Snowmelt runoff was minimal in spring 2006, but several large summer storm events caused runoff primarily at gages E241 and E242.5. The peak mean daily runoff in 2006 at the upper Pajarito Canyon gages was less than 1 cfs.

A large snowmelt runoff occurred from the flanks of the Sierra de los Valles in spring 2007. The runoff at gage E240 occurred for about 75 d, from mid-March to May, with a peak mean daily flow of 2.7 cfs, and totaled about 43 acre-ft. The runoff at gage E241 was significantly less with a peak flow of 0.8 cfs and a total flow of about 12 acre-ft. This indicates a significant loss of runoff between gages E240 and E241 in the upper part of the canyon. Table L-2.0-2 summarizes the spring snowmelt and summer storm runoff volumes at the stream gages in Pajarito Canyon for years 2006, 2007, and spring 2008.

Even more responsive to snowmelt runoff in 2007 than the stream flow at gages E240 and E241 were the spring discharges in Starmer Gulch and Arroyo de la Delfe, as indicated by the flows measured at gages E242 and E242.5, respectively (Figure L-2.0-2). Spring discharges associated with snowmelt runoff in these tributaries began in early March and lasted through June. The maximum mean daily flow in Starmer Gulch was 2.6 cfs, with a total of about 195 acre-ft of flow. It appears that a significant amount of runoff and stream flow from the upper part of Pajarito Canyon west of SR-501 infiltrates into bedrock tuff units along the Pajarito fault zone and issues from downgradient springs in tributaries to Pajarito Canyon. This assumption is also confirmed by comparing chemical and isotopic compositions of surface water collected in Pajarito Canyon above the Pajarito fault zone with discharges at Homestead, Starmer, and Bulldog Springs. The comparison indicates that Homestead and Starmer Springs have a direct link to this surface-water source, while Bulldog Spring may have some connection but is recharged by different sources as well (Dale et al. 2005, 102785).

Figure L-2.0-3 shows the stream flow in middle Pajarito Canyon at gages E243 (Pajarito above Twomile), E244 (Twomile above Pajarito), and E245 (Pajarito above TA-18). The responses to summer storm runoff events are similar at these locations, with flow volumes depending on where runoff occurs within the watersheds. However, much more snowmelt runoff occurred at gages E243 and E245 in Pajarito Canyon than at gage E244 in Twomile Canyon. In 2007, snowmelt runoff occurred at gage E243 from March 1 to the 3rd week in June, with a peak mean daily flow of 2.5 cfs and a total runoff of about 123 acre-ft. In comparison, maximum mean daily snowmelt runoff in Twomile Canyon was less than 1 cfs with a total runoff of about 7 acre-ft.

Peaks flows observed at E243 Pajarito above Twomile and at E244 Twomile above Pajarito are likely buffered by the flood retention structure (FRS) in upper-middle Pajarito Canyon that was constructed after the Cerro Grande fire. Combined peaks from gages E243 and E244 do not typically extend downstream to E245 Pajarito above TA-18. Ponded surface water above the flood retention structure likely provides additional infiltration into the alluvium and bedrock units after large runoff events.

Figure L-2.0-4 shows the stream flow in middle and lower Pajarito Canyon at gages E245 (Pajarito above TA-18), E246 (Threemile above Pajarito), and E250 (Pajarito above SR-4). In spring 2007, snowmelt runoff occurred at gage E245 for 101 d, with a maximum mean daily flow of 4.5 cfs and a total runoff of about 156 acre-ft. A small amount of snowmelt runoff occurred in Threemile Canyon for a total runoff of about 23 acre-ft. Snowmelt runoff did not occur in lower Pajarito Canyon at gage E250 above SR-4 in 2007, indicating that all snowmelt runoff infiltrated in 2007 in middle and lower Pajarito Canyon.

Snowmelt runoff again occurred throughout Pajarito Canyon in spring 2008. As a result of unusual storm runoff events during the winter on November 30 and December 1, 2007, and on January 27 and January 28, 2008, when runoff occurred throughout the canyon, including at E250, the canyon sediments were apparently saturated when the spring snowmelt occurred, and runoff at gage E250 occurred from mid-February through May 2008.

L-3.0 INFILTRATION OF SURFACE WATER

Surface water enters the canyon from springs and runoff. Most of the surface water normally infiltrates into the alluvium and recharges a body of perched alluvial groundwater in the middle and lower canyon. As the groundwater moves through the alluvium, a portion is probably lost to evapotranspiration (ET) because the alluvial groundwater is very near the surface and wetlands form in the lower canyon. The remaining alluvial groundwater seeps into the underlying bedrock or continues to flow downgradient in the alluvium. A small amount of runoff occasionally flows downstream past SR-4 at the Laboratory boundary.

Table L-3.0-1 summarizes the estimated surface-water gains and losses in reaches of Pajarito Canyon during spring snowmelt runoff and summer storm runoff for 2006 and 2007 and spring snowmelt runoff for 2008; Figure L-3.0-1 shows the total estimated surface-water gain/loss for each year. The reaches where gain/loss is calculated are

- below gages E241, E242, E242.5, and above gage E243—upper Pajarito Canyon;
- below gages E243 and E244 and above gage E245—middle Pajarito Canyon; and
- below gages E245 and E246 and above gage E250—lower Pajarito Canyon.

In 2006, almost all runoff was from summer storms, and infiltration losses in each canyon reach were similar and increased in downstream reaches from 62 to 87 to 99 acre-ft, for a total stream loss of 248 acre-ft.

In 2007, a significant amount of snowmelt runoff (107 acre-ft) and storm runoff (379 acre-ft) was lost to infiltration in upper Pajarito Canyon, for a total of 486 acre-ft. However, in middle Pajarito Canyon, due to storm runoff events in the middle canyon in 2007, there was an apparent gain of 72 acre-ft in that reach. In 2007, an estimated 308 acre-ft of runoff was lost in lower Pajarito Canyon, for a total stream loss of 721 acre-ft in 2007.

The snowmelt runoff in the spring of 2008 indicated an estimated stream loss of 146 acre-ft in middle Pajarito Canyon and 81 acre-ft in lower Pajarito Canyon, for a total loss of 166 acre-ft of snowmelt runoff in the spring of 2008.

L-4.0 ALLUVIAL GROUNDWATER

The shallow alluvial groundwater body in Pajarito Canyon extends from below the confluence with Twomile Canyon to the eastern Laboratory boundary at SR-4, a distance of approximately 7 km. The principal source of recharge to the shallow groundwater is infiltration of stream flow from the upper reaches of the canyon supplemented by infiltration of local precipitation. Near TA-18, the canyon widens and the alluvium thickens. At this location, the alluvium is primarily recharged from underflow in the alluvium from upcanyon, ephemeral stream flow in the channel, and spring flow from Threemile Canyon. During heavy snowmelt and summer rainstorms, the stream front occasionally extends down the canyon as far as the Rio Grande.

The abandoned gravel excavations in lower Pajarito Canyon provide ponding areas for surface water and are points of recharge to the alluvial groundwater. Alternately, at times of high groundwater levels, the alluvial groundwater intersects the bottom of the excavations where wetlands are formed. In the summer and fall of 1949, water for use in road construction was obtained from the alluvial groundwater via a pit in lower Pajarito Canyon that was located north of test hole PCTH-6 (see Plate 1). The pit was approximately 30 m (100 ft) long × 11 m (35 ft) wide × 4.5 m (15 ft) deep. Water was pumped from the pit at the rate of 50,000 to 100,000 gpd (190,000 to 3,800,000 L/d) (Black and Veatch 1950, 057575, p. 3). No other use of alluvial groundwater in Pajarito Canyon has been reported.

The only known groundwater discharges in Pajarito Canyon are the springs, the wetlands, a former sump that collected groundwater beneath building TA-18-30, and any losses from ET (Purtymun and Kennedy 1971, 004798, p. 8; LANL 1995, 055527, p. 2-4). A seasonally and yearly variable volume of alluvial groundwater presumably seeps downward into subsurface units through the bedrock at the base of the alluvium. The depth to the regional aquifer near TA-18 is approximately 240 m (800 ft).

Alluvial groundwater levels have been monitored at 11 wells in Pajarito Canyon since mid-2005. Monitoring well 18-BG-1 is located in middle Pajarito Canyon about 1 mi downstream of stream gage E245; this is the farthest upstream alluvial well for which continuous water-level data are available. Monitoring wells 18-BG-4 and 18-MW-8 are located in lower Threemile Canyon; 18-BG-4 is located about 500 ft upstream of stream gage E246, and 18-MW-18 is located about 600 ft downstream of the gage (Plate 1).

Monitoring wells 18-MW-7, 18-MW-7-8, 18-MW-7-9, and 18-MW-7-11 are located at the main TA-18 facility area (Plate 1). Monitoring wells 18-MW-17 and PCO-1 are located about 0.3 mi. downstream from TA-18 in lower Pajarito Canyon, and 18-MW-18 is located another 0.5 mi downstream from 18-MW-17. PCO-2 and PCO-3 are located in lower Pajarito Canyon; PCO-3 is about 900 ft upstream of stream gage E250.

New alluvial monitoring wells were installed in Pajarito Canyon in the summer of 2008, as described in Section 3.2 of this report. Table L-4.0-1 summarizes the construction information for the new and existing alluvial wells in Pajarito Canyon (Appendix G) and Table L-4.0-2 summarizes the recent water-level data from alluvial groundwater monitoring wells in Pajarito Canyon since January 1, 2007.

Monitoring well TMO-1 was installed in lower Twomile Canyon above Pajarito Canyon to a depth of 6.5 ft. The well was dry when installed on June 9 and when checked on July 17, 2008.

Monitoring well PCAO-5 was installed in middle Pajarito Canyon about 100 ft upstream of the FRS. Alluvial groundwater was encountered about 2 ft below ground surface (bgs), and the well was completed through the alluvium (base at 24.7 ft) to a depth of 30 ft. When the well was completed on May 3, 2008, the water level was 6.4 ft bgs at an elevation of 2094 m (6936.9 ft). The water level declined to 10.9 ft bgs at an elevation of 2093 m (6932.4 ft) by July 10, 2008, when a transducer was installed.

Monitoring well PCAO-6 was installed immediately downstream of the FRS in middle Pajarito Canyon. This well encountered bedrock at 17.9.5 ft and was completed to a depth of 20 ft. The well was dry when completed on June 5, 2008, and when a transducer was installed on July 10, 2008.

Monitoring well 3MAO-2 was installed in lower Threemile Canyon downstream from well 18-BG-4. The base of alluvium was encountered at a depth of 24.5 ft. The well was completed to a depth of 30 ft on June 4, 2008, with a water level 18.3 ft bgs at an elevation of 6741.4 ft. The well was bailed dry during well development on June 20. A transducer was installed on July 16, 2008, when the water level was 10.6 ft bgs at an elevation of 6748.79 ft.

PCAO-7a was drilled as part of a transect of monitoring wells immediately downstream of TA-18 facilities; this well is the northernmost well in the transect. The original borehole was drilled to a total depth (TD) of 35 ft with the alluvium/tuff interface at 19.5 ft, and the final well was completed in a second boring to a depth of 25 ft. The well did not encounter groundwater when drilled and was dry at completion of the well on May 30, 2008, but before well development on June 12, 2008, the water level was 10.89 ft bgs. A transducer was installed on July 10, 2008, when the water level was 8.9 ft bgs at an elevation of 6703.05 ft.

PCAO-7b1 (TD of 65 ft bgs) and PCAO-7b2 (TD of 25 ft bgs) were completed as monitoring wells on May 21, 2008 and May 27, 2008, respectively, about 10 ft apart. PCAO-7b1 is screened from 44 to 54 ft bgs, and PCAO-7b2 is screened from 10 to 20 ft bgs. The groundwater level was 56.28 ft bgs in the sump (well dry) at PCAO-7(b1) and at 11.05 ft bgs at PCAO-7b2 on May 28, 2008. Well development began on June 13, 2008, at PCAO-7b1 when it was bailed dry, and it remained dry. PCAO-7b2 was developed on June 16, 2008, and was also bailed dry; however, the well displayed consistent slow recovery. Transducers were installed on July 11, 2008, in each well when PCAO-7b1 was dry with water in the sump, and PCAO-7b2 contained water at 13.6 ft bgs at an elevation of 6699.8 ft.

PCAO-7c is located on the south side of Pajarito Road near the stream channel. The initial borehole was drilled to a TD of 66 ft bgs, 8 ft below the alluvium/tuff interface at 58.1 ft bgs. Because of completion problems, a replacement borehole was drilled 23 ft upstream (west) of the original location and the original borehole was abandoned. The second PCAO-7c boring was drilled to 25 ft. A well was constructed on May 16, 2008, with a screened interval from 9.7 to 19.7 ft bgs. Water was encountered during drilling at 6.3 ft bgs. Well development began on May 21, 2008, and was completed on June 11, 2008. The water level was measured after development at 10.56 ft bgs. A transducer was installed on July 10 when the water level was 8 ft bgs at an elevation of 6706.5 ft.

PCAO-8 is located on the south side of Pajarito Road in lower Pajarito Canyon between monitoring wells PCO-2 and PCO-3. The borehole was drilled to a TD of 45 ft bgs; the alluvium/tuff contact was encountered at 41.2 ft bgs, and a monitoring well was installed on June 02, 2008, with a screen from 9.7 to 19.7 ft bgs. The water level was 5.75 ft bgs when the well was completed. Well development began on June 19, 2008, when the water level was 9.2 ft bgs, but the well bailed dry during development. A transducer was installed on July 17, 2008, when the water level was 12.15 ft bgs at an elevation of 6572.3 ft.

PCAO-9 is located on the south side of Pajarito Road about 0.25 mi west of the security check point and about 100 ft upstream of monitor well PCO-3. The borehole was drilled to a TD of 25 ft bgs, and the alluvium/tuff contact was encountered at 16.2 ft bgs. The well was installed on June 12, 2008, with a screen from 6 to 16 ft bgs. After well development on June 19, 2008, the water level was 7.75 ft bgs. A transducer was installed on July 15, 2008, when the water level was 7.67 ft bgs at an elevation of 6550.93 ft.

Alluvium in upper Pajarito Canyon above Twomile Canyon and in Twomile Canyon is generally narrow and sparse in the canyon bottom with no significant perched alluvial groundwater present. The alluvium in lower Twomile Canyon at monitoring well TMO-1 was cobbles and difficult to penetrate with hand auger tools. Below the confluence of Twomile Canyon at PCAO-5, the alluvium is at least 25 ft thick, but at PCAO-6 a few hundred feet downstream, the alluvium was found to be about 17.7 ft thick.

Alluvium is thickest in wells R-20 (68 ft), PCO-7c (58.1 ft), and R-32 (47 ft). The alluvium is approximately 35 to 40 ft thick at TA-18, 11 ft thick at PCO-1, 9 ft thick at PCO-2, and 12 ft thick at PCO-3. The alluvium thickness appears to be asymmetric relative to the surface axis of the canyon. For example, alluvium thickens from north (19.5 ft) to south (66 ft) along the PCOA-7 well transect. Similarly, alluvium thickens from north to south at PCO-1 (11 ft) and R-20 (68 ft), respectively. The alluvium is widest in the lower part

of the canyon south of TA-54. Eastward from well R-32, the alluvium thins until the stream channel rests directly on basalt bedrock east of SR-4.

L-5.0 ALLUVIAL GROUNDWATER RESPONSE TO RUNOFF

Middle Pajarito Canyon

Figure L-5.0-1 shows the mean daily stream flow at gages E243 (Pajarito above Twomile), E244 (Twomile above Pajarito), and E245 (Pajarito above TA-18) and the alluvial groundwater levels in monitoring wells 18-BG-1 above TA-18 and 18-MW-9 and 18-MW-11 (at TA-18) for 2007 and spring 2008. Alluvial groundwater fluctuations in response to runoff events are greatest at 18-BG-1 where the canyon is narrow; responses are less in downstream wells as the canyon widens. The response at 18-BG-1 occurs within a few days, depending on runoff volume at stream gage E245, with responses of up to 15 ft when runoff is present at the gage. Because of the narrow canyon at this location, alluvial storage is less, which leads to large water-level changes in response to infiltrating surface water. Groundwater-level decline at 18-BG-1 is more gradual and can take over a month to return to prestorm water levels. Water loss from the alluvium at this location may be a combination of lateral flow to downcanyon alluvium and infiltration into bedrock units.

Figure L-5.0-2 shows the runoff and alluvial groundwater levels in middle Pajarito Canyon during the spring and summer of 2007. Monitoring well 18-BG-1 is the westernmost monitoring well for which data are available in middle Pajarito Canyon and is located about 1200 ft downstream from stream gage E245. In 2007, snowmelt runoff began at gage E245 on February 28 and mean daily runoff peaked at 4.5 cfs on March 24. The water level at 18-BG-1 began to rise on March 20 in response to the runoff and rose about 14 ft from March 20 to March 25.

The water level in monitoring well 18-MW-9 shows an apparent response to early snowmelt runoff beginning on February 11 when the water level rose about 2 ft even before runoff was measured at stream gage E245 (Figure L-5.0-2). The water level in 18-MW-9 rose about 4.5 ft in response to the high snowmelt runoff on March 22 when runoff extended downcanyon in the channel through TA-18. This well is about 50 ft from the stream channel and responded quickly to runoff in the channel. Monitoring well 18-MW-11 is located about 300 ft from the stream channel. The water level in this well gradually rose about 1.4 ft on February 11 in apparent response to early snowmelt runoff; in response to the high runoff, the water level rose about 6 ft on March 27, about 5 d after the response was observed at well 18-MW-9.

Monitoring wells 18-MW-9 and 18-MW-11 are located in Pajarito Canyon at TA-18 just below the confluence with Threemile Canyon. The alluvial water levels here respond fairly rapidly (within 1–2 d) to large flow events at E245 but can take over a week to reach full response levels. For large storm runoff events that extend downstream to gage E250, the response in alluvial groundwater response is initiated the same day, with 18-MW-9 (closer to channel) having a more rapid response than 18-MW-11. The lag in water-level response at 18-MW-11 probably indicates that water is infiltrating from the stream channel, and the alluvial water levels propagate laterally from the channel. Water-level declines are more gradual in wells at TA-18 than at 18-BG-1. The alluvium here is deeper and wider, which provides additional storage. Water loss from the alluvium is likely a combination of lateral flow to downcanyon alluvium and infiltration into bedrock units. Because of the wider alluvium at TA-18, the potential for infiltration into bedrock units is likely greater than in the reaches upstream.

Monitoring well 18-BG-4 is located in Threemile Canyon about 500 ft upstream of gage E246; monitoring well 18-MW-8 is located about 600 ft downstream from the gage (Plate 1). In April 2007, the alluvial groundwater at 18-BG-4 rose about 1 wk before snowmelt runoff was recorded at E246 (Figure L-5.0-3). The water level at 18-MW-8 began rising about 1 wk after runoff began at gage E246 and about 2 wk

after the increased water level was observed in 18-BG-4. The groundwater responses in Threemile Canyon are not associated with the high runoff observed in Pajarito Canyon in March 2007. Similarly, summer storm runoff in September 2007 in Pajarito Canyon is reflected in higher groundwater levels in 18-BG-1 and 18-MW-9 in Pajarito Canyon, but no response is observed in the Threemile Canyon alluvial groundwater.

The observed responses to spring snowmelt runoff in Threemile Canyon in 2007 might indicate alluvial groundwater response in Threemile Canyon related to subsurface flow and spring discharges that may originate from middle Pajarito Canyon (see Threemile spring discussion in Appendix K-2.0). In this case, the alluvial water level in Threemile Canyon may rise in response to alluvial groundwater head increases in middle Pajarito Canyon and provide emergence for the springs in Threemile Canyon. The groundwater elevation at 18-BG-4 in Threemile Canyon is similar to the elevation of the groundwater at 18-BG-1 in middle Pajarito Canyon, between 6760 and 6770 ft. The rising water level at 18-BG-4 in April 2007 occurred about 16 d after the water level rose in response to snowmelt runoff in Pajarito Canyon.

The alluvial groundwater levels in middle Pajarito Canyon are generally lowest from November to February because snowfall precipitation during this time is not available for infiltration, and recharge from upstream areas is at a minimum. Water levels are highly variable during the spring and summer months, primarily because of the variability in seasonal runoff. The amount of fluctuation in alluvial groundwater levels decreases downcanyon, probably because of widening of the canyon and an associated increase in the volume and storage of the alluvial groundwater.

Lower Pajarito Canyon

Alluvial water level changes in lower Pajarito Canyon downstream of TA-18 (Figure L-5.0-4) are more subdued than in middle Pajarito Canyon. Water-level fluctuations in the lower part of the canyon are typically less than 5 ft, possibly because of the volume of storage in the alluvium. In response to large storm runoff events in the stream channel between gages E245 and E250, the water level in monitoring well 18-MW-17 rises quickly (about the same day) and declines slowly over several weeks. When large runoff events extend to E250, the groundwater levels at 18-MW-18 and PCO-2 rise quickly and decline slowly over several months. During snowmelt runoff in 2007 and 2008, the water level at PCO-2 remained elevated as long as runoff occurred but declined as soon as runoff ceased, indicating that the water level is recharged, at least in part, from the stream channel. The alluvial groundwater at 18-MW-18 and PCO-2 does not dry up during prolonged lack of runoff, indicating that the alluvial groundwater is perched with probable lateral flow occurring in the alluvium and smaller volumes infiltrating into deeper bedrock units. The alluvial groundwater levels indicate that flow reaches these wells both by stream flow and by lateral flow in the alluvium, with the stream flow yielding rapid rise/fall and the alluvial flow occurring over longer time scales. The slow declines following runoff and the flatter floor of the alluvium canyon (see Figure 7.2-1) indicate potential infiltration here.

The water level at 18-MW-18 is much less responsive because of distance to the active stream channel. The groundwater distal from the channel does not appear to be affected by stream flow or lateral flow; only the large snowmelt runoff in spring 2007 produced a slow water-level rise of about 1 ft that dissipated quickly when runoff ceased.

The alluvial groundwater level at PCO-3 in lower Pajarito Canyon is relatively constant except during prolonged periods without runoff in the lower canyon. For example, the groundwater level declined about 14 ft over a period of approximately 4 wk during June 2007 and again during October and November 2007. The alluvial groundwater at PCO-3 recovers quickly when runoff occurs at E250 and in January 2008 responded to a large winter storm runoff event. After snowmelt runoff ceased at gage E250 in spring 2008, the alluvial groundwater level began to decline at PCO-3 within a few days. The alluvial

groundwater responses at PCO-3 indicate that groundwater is infiltrating into deeper bedrock units (Cerros del Rio basalt) in this section of the canyon. The alluvium recharges from the channel and possibly from lateral flow from upstream alluvium in response to runoff, but alluvial groundwater then drains away within about 1 mo. Figure 7.2-1 shows thin alluvium in the lower part of Pajarito Canyon, which thins downstream at the Laboratory boundary where the stream channel flows on basalt bedrock. Fractures in the basalt may facilitate the rapid drainage observed at PCO-3.

L-6.0 POTENTIAL DEEP INFILTRATION FROM ALLUVIAL GROUNDWATER TO UNDERLYING BEDROCK

Alluvial groundwater-level responses in monitoring wells in middle and lower Pajarito Canyon show seasonal responses to snowmelt and storm runoff. The alluvial groundwater levels in all sections of the canyon rise quickly in response to runoff in the stream channel. Alluvial groundwater levels in the middle canyon and lower canyon downstream to PCO-2 show slow declines in water levels after runoff events, which suggests that lateral flow of alluvial groundwater downcanyon and/or relatively slow infiltration into deeper bedrock units occurs. In lower Pajarito Canyon at PCO-3, the alluvial groundwater is present during times of runoff, both locally, and runoff in the upper part of the canyon, indicating lateral flow of alluvial groundwater downcanyon to that point. However, the alluvial groundwater at PCO-3 quickly declines 10 or more ft during prolonged periods of no runoff. This suggests relatively rapid recharge of the alluvial groundwater into the deeper bedrock unit, which at this location is Cerros del Rio basalts under a thinning alluvium on the flanks of a basalt high (Figure 7.2-1). Alluvial groundwater disappears eastwards in lower Pajarito Canyon where basalt forms a bedrock channel. Presumably alluvial groundwater infiltrates bedrock as far east as PCO-3 or R-23. Some of the shallow alluvial groundwater is also lost through ET in wetland areas of lower Pajarito Canyon.

Two methods are used to estimate infiltration rates from the alluvial groundwater body into the underlying bedrock, a calibration technique and a water balance comparison.

For the first method, infiltration rates are calculated by applying the measured vadose-zone gravimetric moisture contents in an equation that describes vadose-zone hydrologic properties. Gravimetric moisture contents were measured on core samples collected from the vadose zone during drilling of monitoring wells R-17, R-20 and R-32 (Appendix H). Between Twomile Canyon and gage E250, unit Qbt 1g underlies the alluvium in much of the canyon floor, and the gravimetric moisture content ranges from approximately 13% to 25% in that unit (Figure H-1.0-1). Mualem's empirical formula describes the variation in the unsaturated hydraulic conductivity (K_{eff}) as a function of moisture content (Mualem 1976, 063543; Van Genuchten 1980, 063542). If recharge is considered to be nearly steady, a calculated value of K_{eff} , using field moisture contents and Mualem's formulation for the particular rock type, is assumed equivalent to the infiltration rate. Springer (2005, 098534) determined the parameters used in Mualem's formula for a number of Bandelier Tuff core samples at different locations across the Laboratory. Here, mean values of hydrologic properties measured on Qbt 1g core samples collected from Canada del Buey (Springer 2005, 098534) were used to estimate the range of infiltration rates of between 15 and 900 mm/yr in middle and lower Pajarito Canyon.

For the second method, a volumetric water balance approach compares stream flow volumes and the extents of the alluvial groundwater bodies in Pajarito and Sandia Canyons to approximate infiltration rates from the alluvial groundwater into the underlying bedrock. Infiltration rates estimated for recharge areas in lower Sandia Canyon ranged between 1,000 and 6,000 mm/yr based on calibration to measured vadose-zone moisture contents and contaminant profiles, and based on an alluvial water-balance study (LANL 2008, 102996).

Average stream flow to the middle and lower portions of Pajarito Canyon, based on combined stream gages E245 and E246, is 0.36 cfs (Figure L-2.0-1), while average effluent discharges to Sandia Canyon

range between 0.5 and 0.6 cfs with surface water flow contributing an additional 20-25% more water (LANL 2008, 102996). Pajarito Canyon receives less stream flow (roughly half) than does Sandia Canyon; in both canyons, stream flow recharges alluvial groundwater, which in turn (largely) infiltrates to underlying bedrock.

The extent of alluvial groundwater in Pajarito Canyon is much greater (approximately 7 km along the length of the canyon) than in Sandia Canyon (approximately 1.8 km along the length of the canyon). Based on the observed wetlands in Pajarito Canyon (Plate 1), the lateral (cross canyon) extent of alluvial groundwater is also likely to be greater there than in Sandia Canyon. The contact area between the alluvial groundwater body and the underlying bedrock determines the aerial extent over which deep infiltration can occur, which is greater in Pajarito Canyon than in Sandia Canyon, and the relative ratio can be approximated as (7 km/1.8 km), or roughly 4.

On average, lower deep infiltration rates likely occur in Pajarito Canyon than in Sandia Canyon because less water infiltrates over a greater area in Pajarito Canyon. A simple comparison between the volumetric flow rates to the canyons and the aerial extent of alluvial groundwater yields a prediction for infiltration rates in Pajarito Canyon of 1/8th to 1/10th those in Sandia Canyon. Based on the estimated 1000 to 6000 mm/yr infiltration rates for Sandia Canyon, this simple comparison predicts infiltration rates of 100 to 750 mm/yr.

These two approaches yield similar ranges for infiltration rates (15 to 900 mm/yr and 100 to 750 mm/yr) for middle and lower Pajarito Canyon. Infiltration patterns may be quite steady (temporally) where unit Qbt 1g is present (Figure 7.2-1) because alluvial groundwater levels there are nearly constant (Figures L-5.0-1 and L-5.0-4), although preferential flow paths may be present and still maintain steady water levels. These averaged rates likely do not apply near wells R-23 and PCO-3 where infiltration is likely to be more transient and may be more focused and quite rapid through the fractured basalt, as indicated by water-level fluctuations measured at well PCO-3 (Figure L-5.0-4).

L-7.0 PERCHED INTERMEDIATE GROUNDWATER

Perched-intermediate groundwater is present beneath Pajarito Canyon at R-19 (screen 2), R-17, and R-23i. Figure L-7.0-1 shows the time series of intermediate groundwater levels observed at R-19 screen 2. The water level shows a seasonal rise of about 1 ft over 4 yr. The water-level rise could be associated with a long-term recovery of a very limited intermediate groundwater zone following installation of the Westbay sampling system after the intermediate well screen had been open to other screens. This could indicate either a very limited areal extent of the intermediate zone, a low permeability zone, or a long-term recharge of the intermediate zone.

During drilling of regional aquifer monitoring well R-17, an intermediate perched zone was encountered (Figure 7.2-1) in dacitic lavas and in the Puye Formation. There is no well installed in the intermediate groundwater at this location, and the water level cannot be monitored.

Figure L-7.0-2 shows the R-23i intermediate groundwater levels at screens 2 and 3, after the water-level data are corrected for atmospheric pressure fluctuations. The perched-intermediate water levels in screen 2 show a slow constant decline from early 2006 to April 2008 of about 2 ft. Starting in April 2008, the water levels at both zones rise, which may be associated with infiltration of snowmelt runoff in the lower part of Pajarito Canyon (or may be associated with lateral flow in the Cerros del Rio basalts from runoff infiltration in lower Los Alamos Canyon). Runoff at gage E250 in lower Pajarito Canyon is also shown in Figure L-7.0-2. The runoff began in late February 2008 and continued until the end of May or early June. The increased water levels in R-23i appear to occur about 40 d after the start of snowmelt runoff. Additional monitoring of R-23i groundwater may help establish whether the perched-intermediate

groundwater is recharged from runoff or infiltration of alluvial groundwater in Pajarito Canyon or comes from some other water source.

L-8.0 REFERENCES

The following list includes all documents cited in this appendix. Parenthetical information following each reference provides the author(s), publication date, and ER ID number. This information is also included in text citations. ER ID numbers are assigned by the Environmental Programs Directorate's Records Processing Facility (RPF) and are used to locate the document at the RPF and, where applicable, in the master reference set.

Copies of the master reference set are maintained at the New Mexico Environment Department Hazardous Waste Bureau; the U.S. Department of Energy–Los Alamos Site Office; the U.S. Environmental Protection Agency, Region 6; and the Directorate. The set was developed to ensure that the administrative authority has all material needed to review this document, and it is updated with every document submitted to the administrative authority. Documents previously submitted to the administrative authority are not included.

- Black and Veatch, 1950. "Report on Water Supply Investigation in Pajarito Canyon, Los Alamos, New Mexico," Kansas City, Missouri. (Black and Veatch 1950, 057575)
- Blake, W.D., F.E. Goff, A.I. Adams, and D. Counce, May 1, 1995. "Environmental Geochemistry for Surface and Subsurface Waters in the Pajarito Plateau and Outlying Areas, New Mexico," Los Alamos National Laboratory report LA-12912-MS, Los Alamos, New Mexico. (Blake et al. 1995, 049931)
- Dale, M.R., F. Goff, K. Granzow, P. Longmire, and D. Counce, October 16–19, 2005. "Assessing Ground-Water Recharge through the Pajarito Fault Zone, Upper Pajarito Canyon, Los Alamos, New Mexico," poster presented at the Annual Meeting of the Geological Society, October 16–19, 2005, Salt Lake City, Utah. (Dale et al. 2005, 102785)
- Gallaher, B.M., and R.J. Koch, September 2004. "Cerro Grande Fire Impacts to Water Quality and Stream Flow near Los Alamos National Laboratory: Results of Four Years of Monitoring," Los Alamos National Laboratory report LA-14177, Los Alamos, New Mexico. (Gallaher and Koch 2004, 088747)
- Griggs, R.L., and J.D. Hem, 1964. "Geology and Ground-Water Resources of the Los Alamos Area, New Mexico," U.S. Geological Survey Water Supply Paper 1753, Washington, D.C. (Griggs and Hem 1964, 092516)
- John, E.C., E.A. Enyart, and W.D. Purtymun (Comps.), October 1966. "Records of Wells, Test Holes, Springs, and Surface-Water Stations in the Los Alamos Area, New Mexico," U.S. Geological Survey Open-File Report, Albuquerque, New Mexico. (John et al. 1966, 008796)
- LANL (Los Alamos National Laboratory), November 2, 1995. "RFI Report for Potential Release Sites 18-002(a–c), 18-003(a–h), 18-004(a,b), 18-005(a), 18-008, 18-010(b–f), 18-011, 18-012(a–c), 18-013, 27-002, PCO Wells, LACEF Monitoring Wells, Wetlands (located in former Operable Unit 1093)," Los Alamos National Laboratory, Los Alamos, New Mexico. (LANL 1995, 055527)
- LANL (Los Alamos National Laboratory), July 2008. "Fate and Transport Investigations Update for Chromium Contamination from Sandia Canyon," Los Alamos National Laboratory document LA-UR-08-4702, Los Alamos, New Mexico. (LANL 2008, 102996)

- Mualem, Y., June 1976. "A New Model for Predicting the Hydraulic Conductivity of Unsaturated Porous Media," *Water Resources Research*, Vol. 12, No. 3, pp. 513-522. (Mualem 1976, 063543)
- Purtymun, W.D., and W.R. Kennedy, May 1971. "Geology and Hydrology of Mesita del Buey," Los Alamos Scientific Laboratory report LA-4660, Los Alamos, New Mexico. (Purtymun and Kennedy 1971, 004798)
- Springer, E.P., 2005. "Statistical Exploration of Matrix Hydrologic Properties for the Bandelier Tuff, Los Alamos, New Mexico," *Vadose Zone Journal*, Vol. 4, pp. 505-521. (Springer 2005, 098534)
- Stearns, H.T., July 15, 1948. "Ground-water Supplies for Los Alamos, New Mexico," Los Alamos Scientific Laboratory, Los Alamos, New Mexico. (Stearns 1948, 011871)
- Van Genuchten, M.T., 1980. "A Closed-Form Equation for Predicting the Hydraulic Conductivity of Unsaturated Soils," *Soil Science Society of America Journal*, Vol. 44, pp. 892-898. (van Genuchten 1980, 063542)

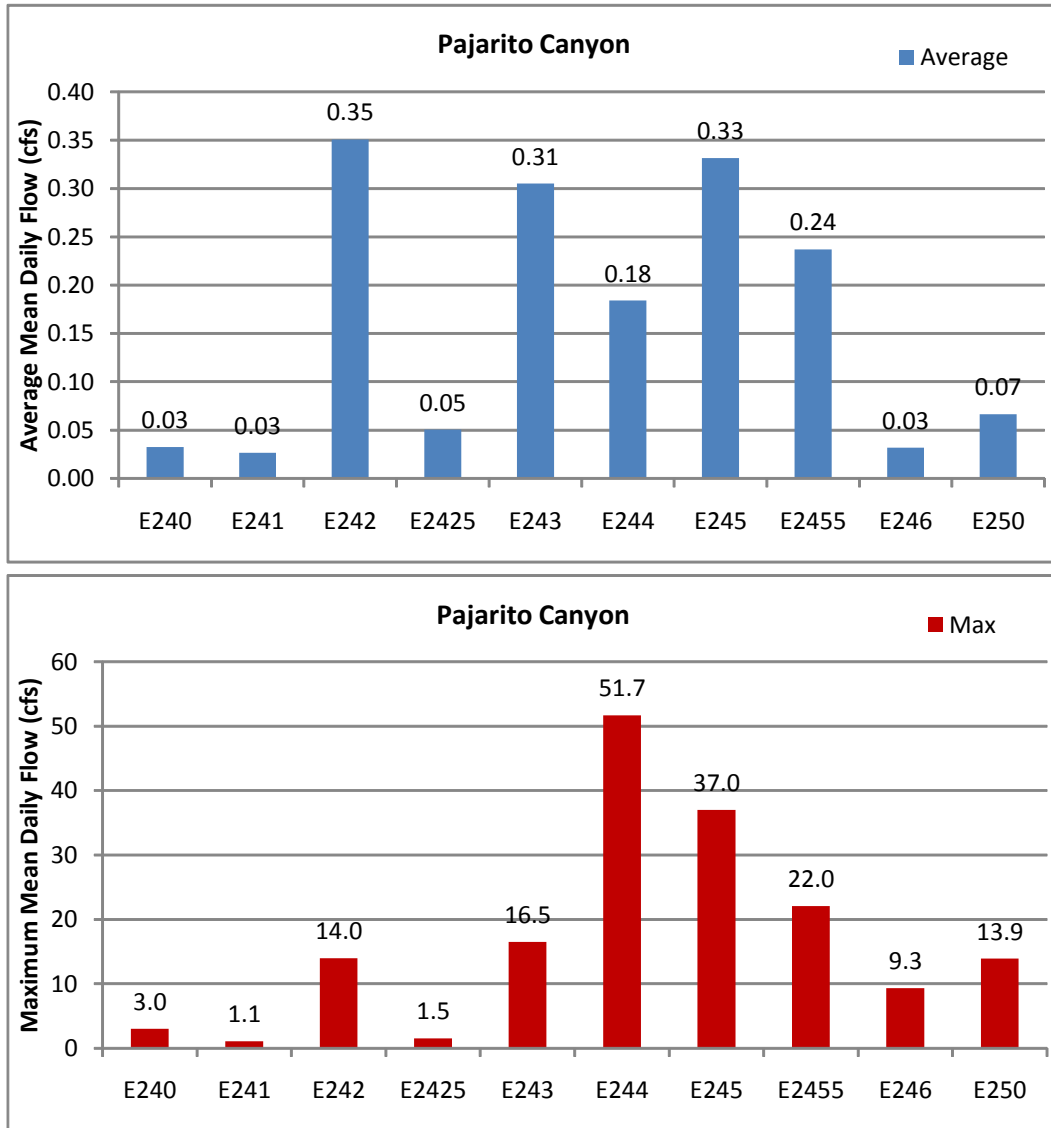

Figure L-2.0-1 Summary of average and maximum mean daily flows at stream gages in Pajarito Canyon from June 2005 to June 2008

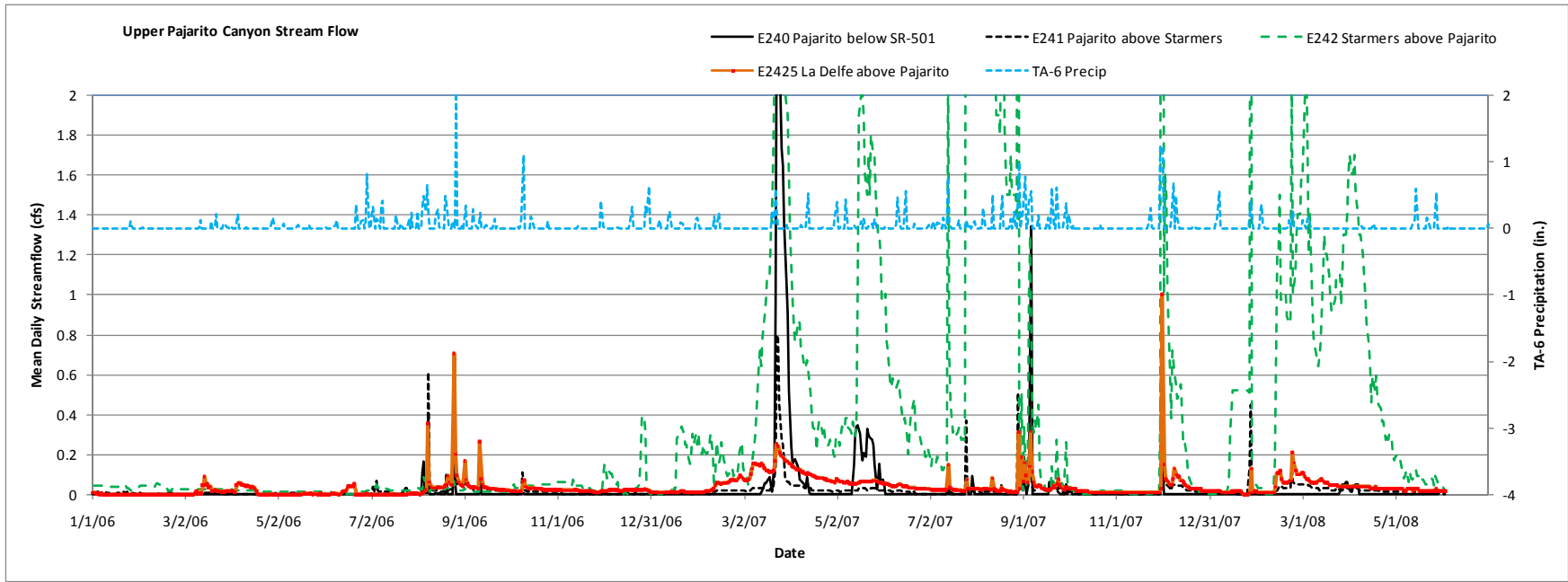

Figure L-2.0-2 Stream flow in upper Pajarito Canyon from January 2006 to June 2008

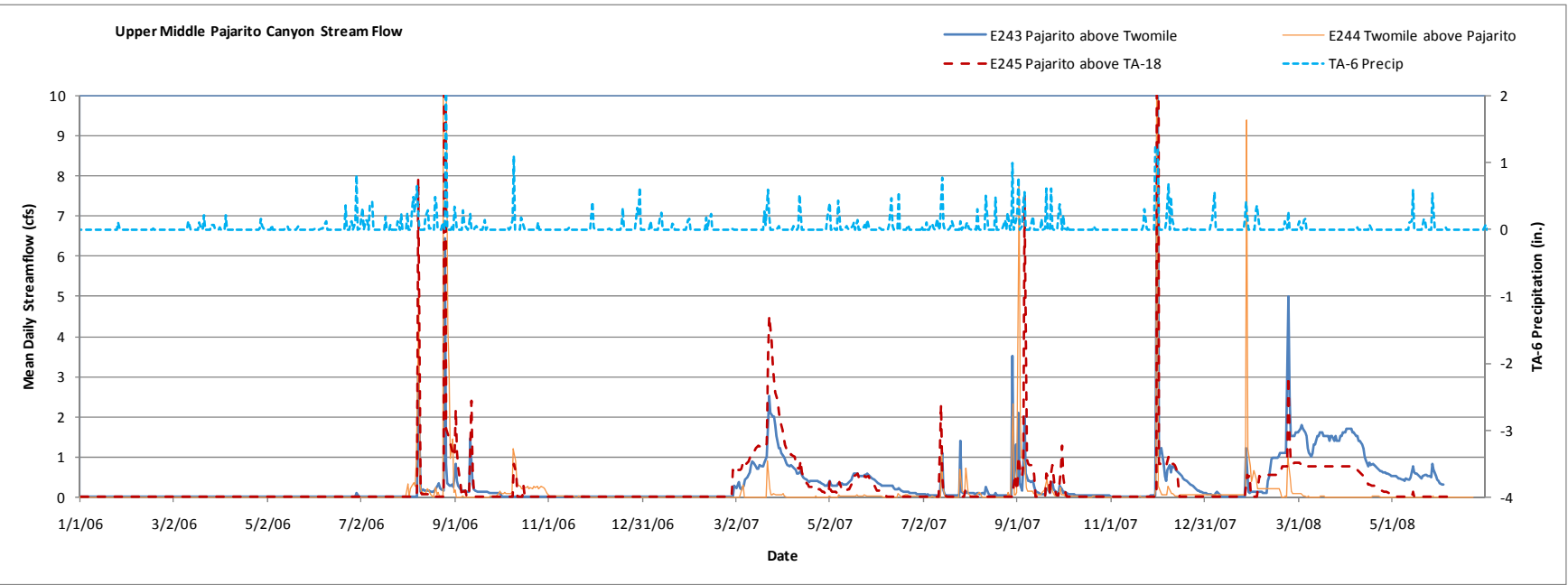

Figure L-2.0-3 Stream flow in middle Pajarito Canyon from January 2006 to June 2008

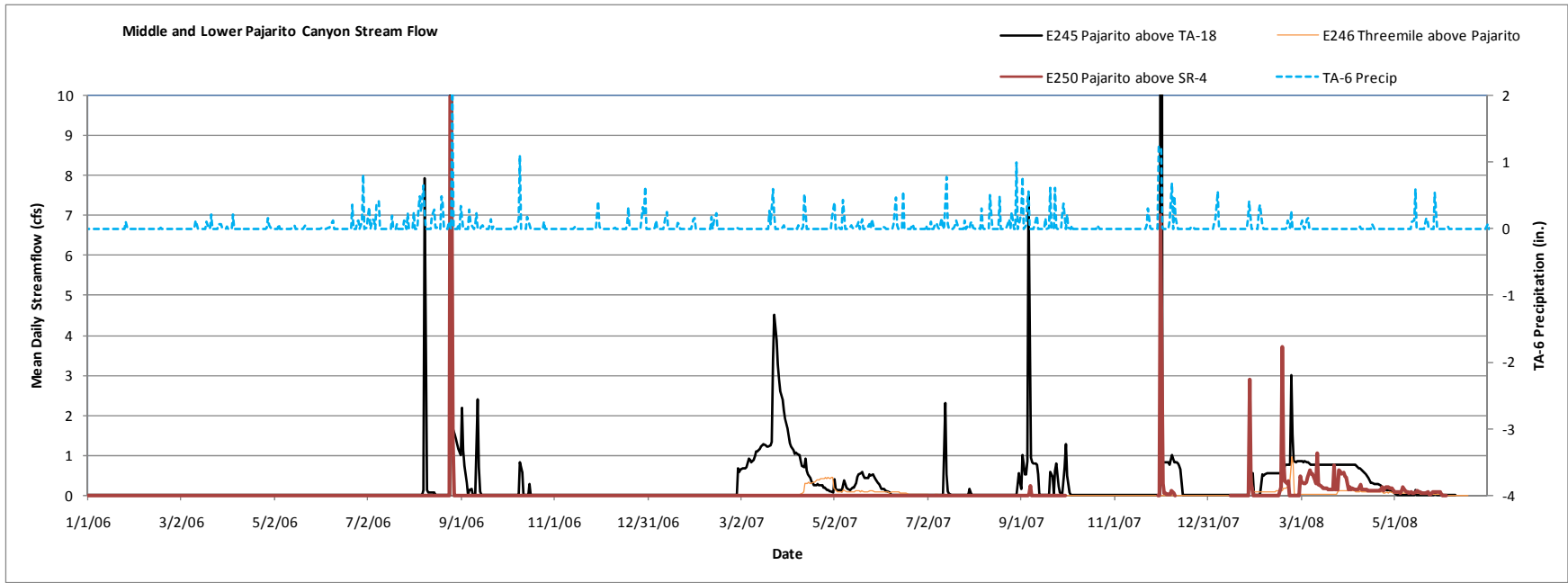

Figure L-2.0-4 Stream flow in middle and lower Pajarito Canyon from January 2006 to June 2008

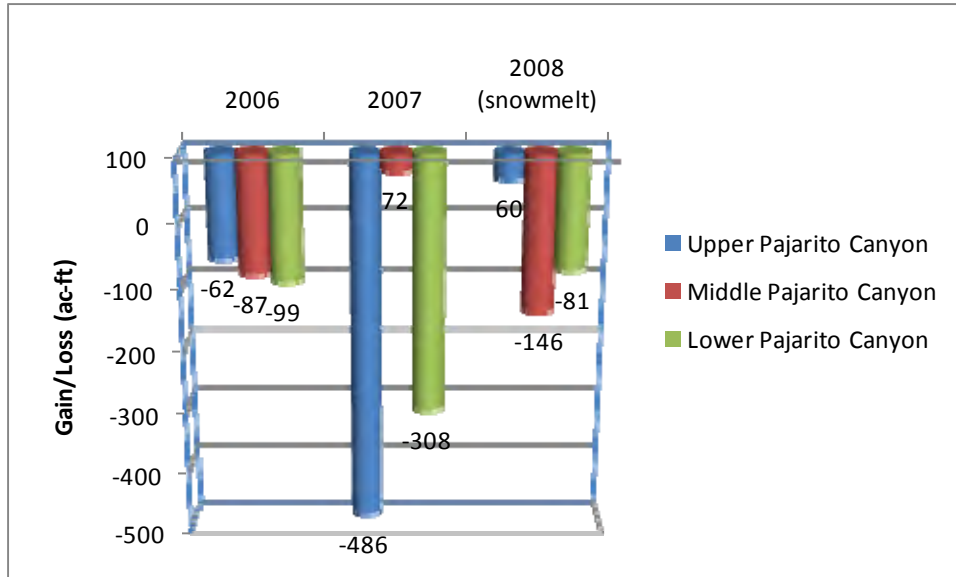

Figure L-3.0-1 Estimated total stream gain/loss in Pajarito Canyon reaches from 2006 to 2008

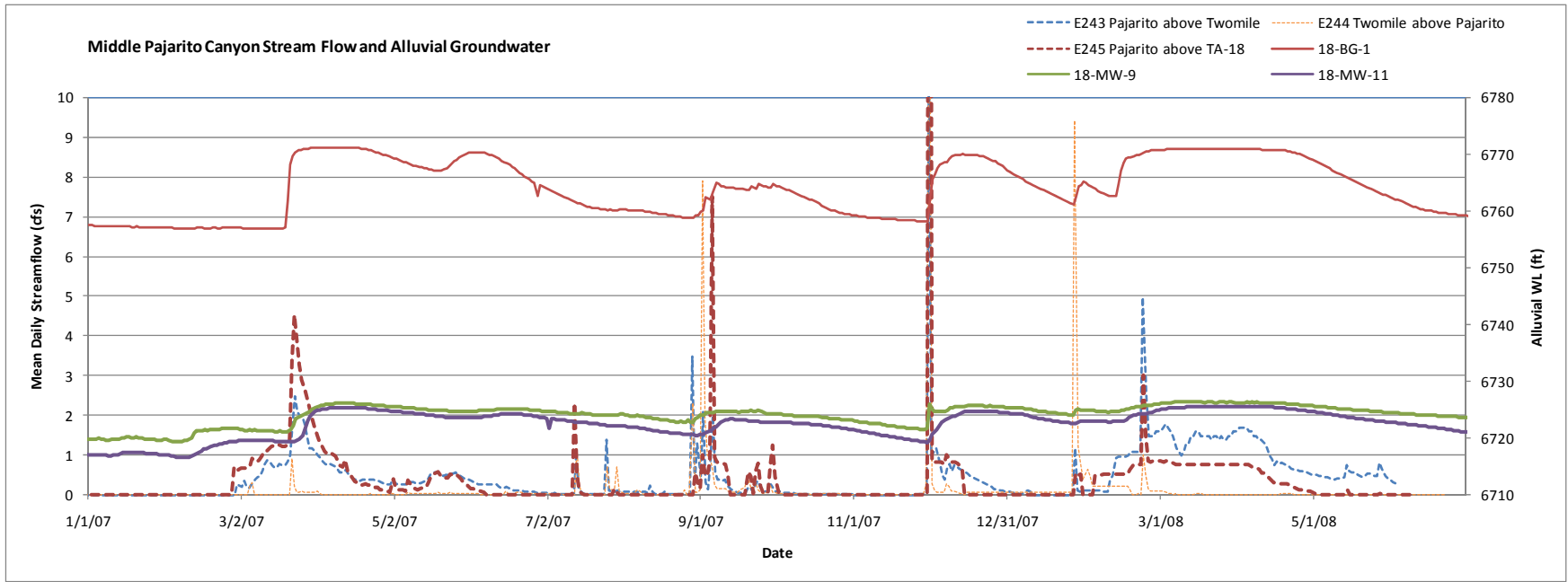

Figure L-5.0-1 Stream flow and alluvial groundwater levels in middle Pajarito Canyon

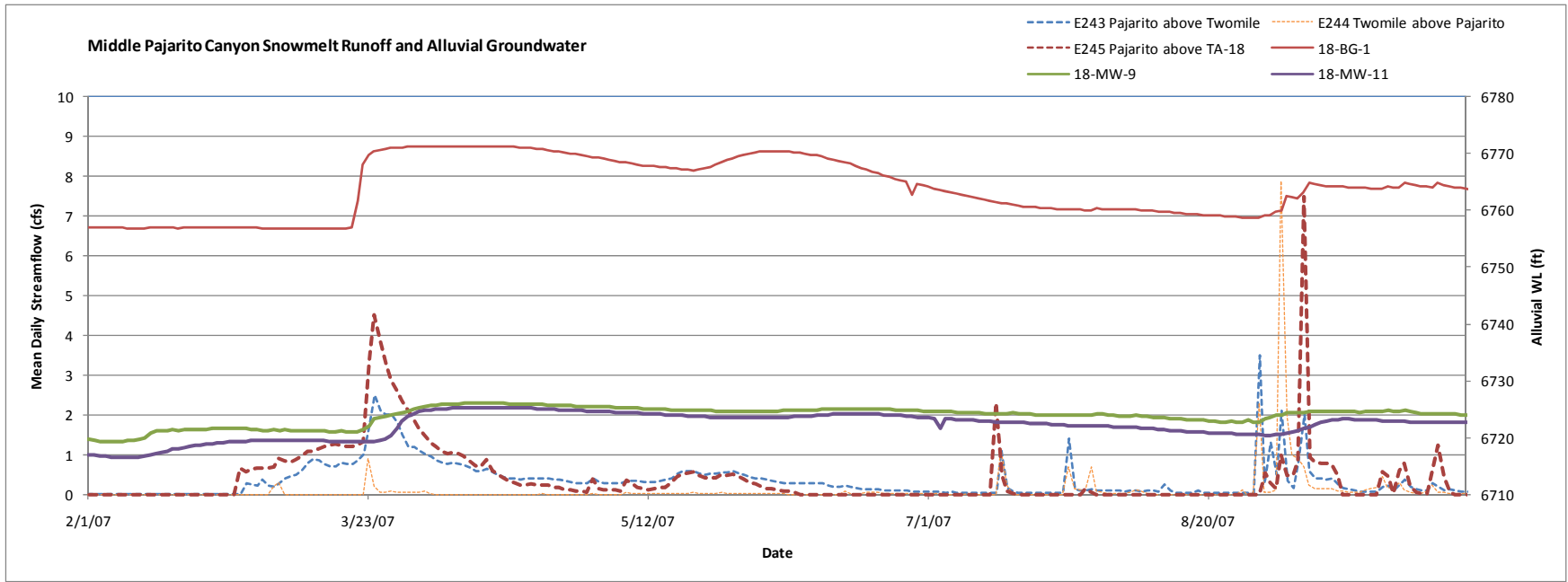

Figure L-5.0-2 Snowmelt runoff and alluvial groundwater levels in middle Pajarito Canyon in spring 2007

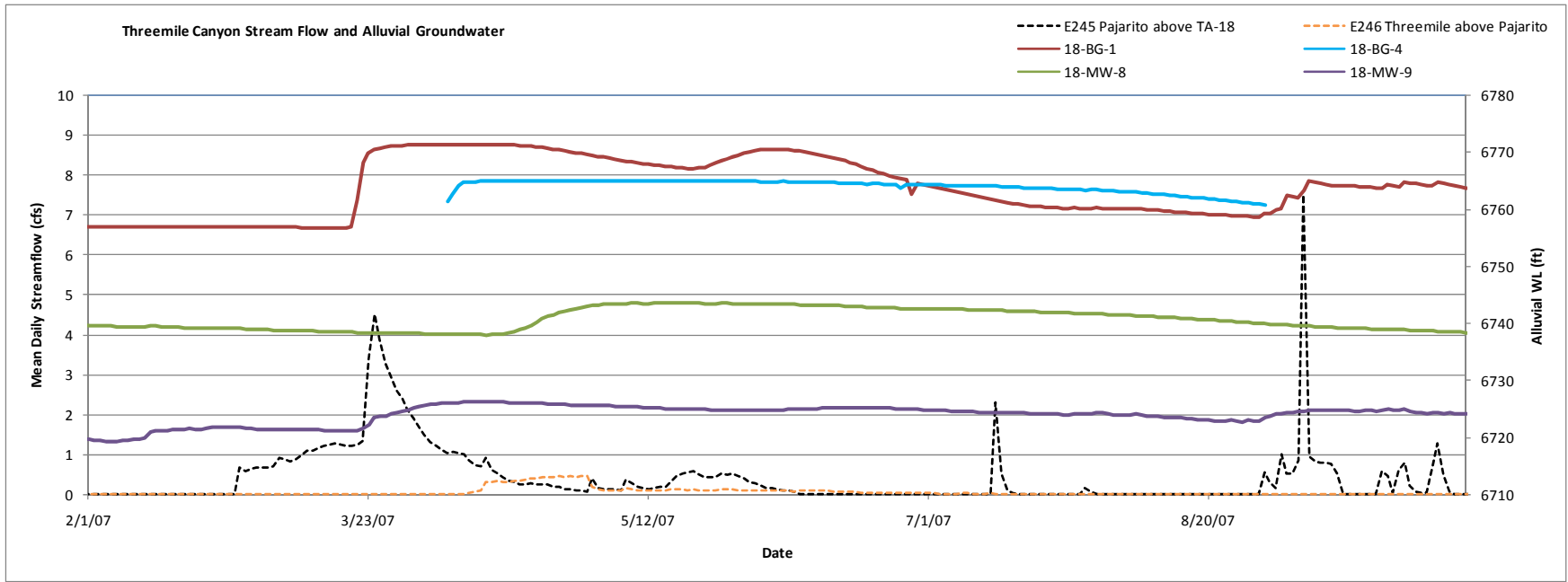

Figure L-5.0-3 Runoff and alluvial groundwater levels in Threemile Canyon and Pajarito Canyon in 2007

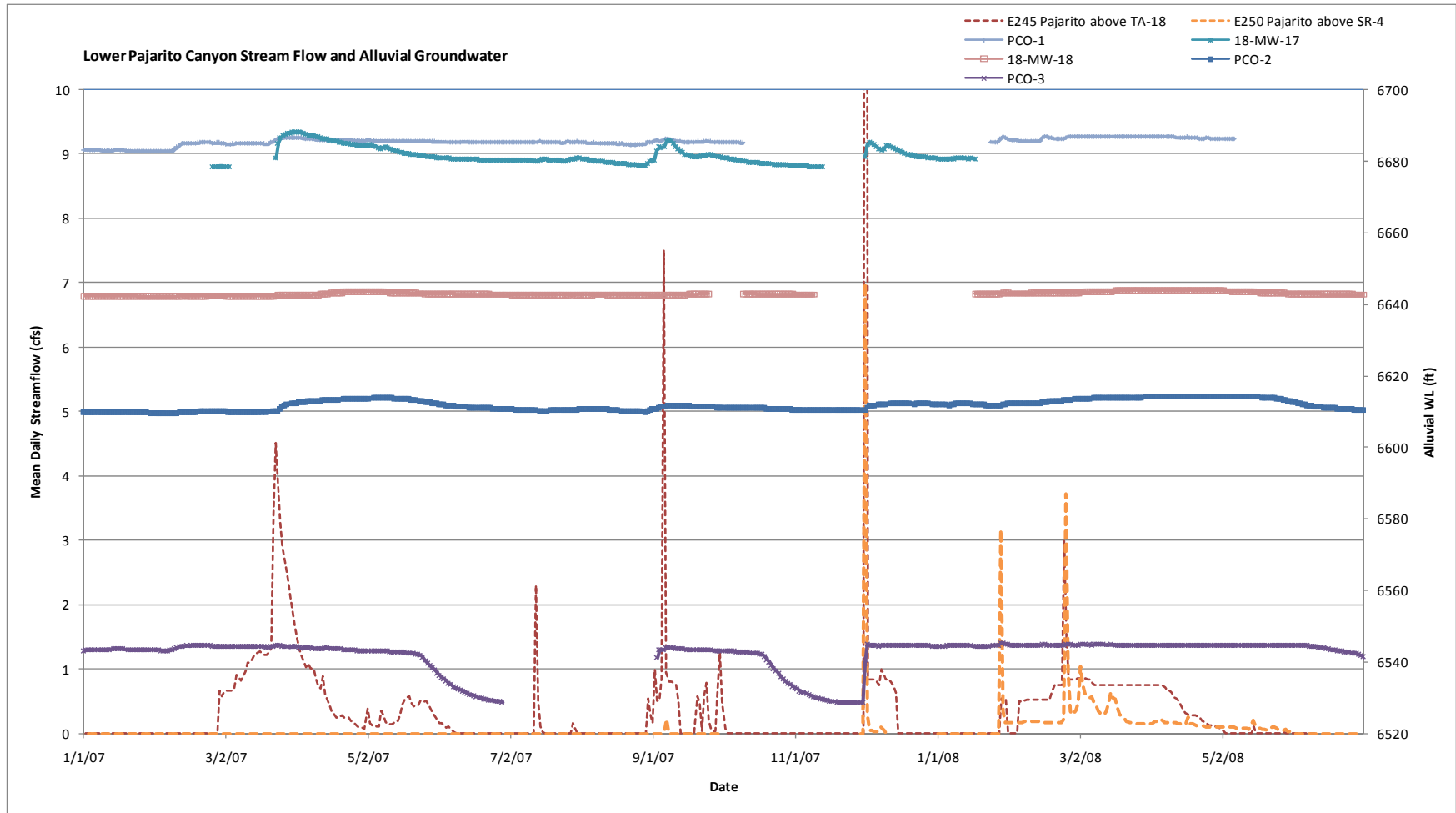

Figure L-5.0-4 Runoff and alluvial groundwater in lower Pajarito Canyon in 2007 and 2008

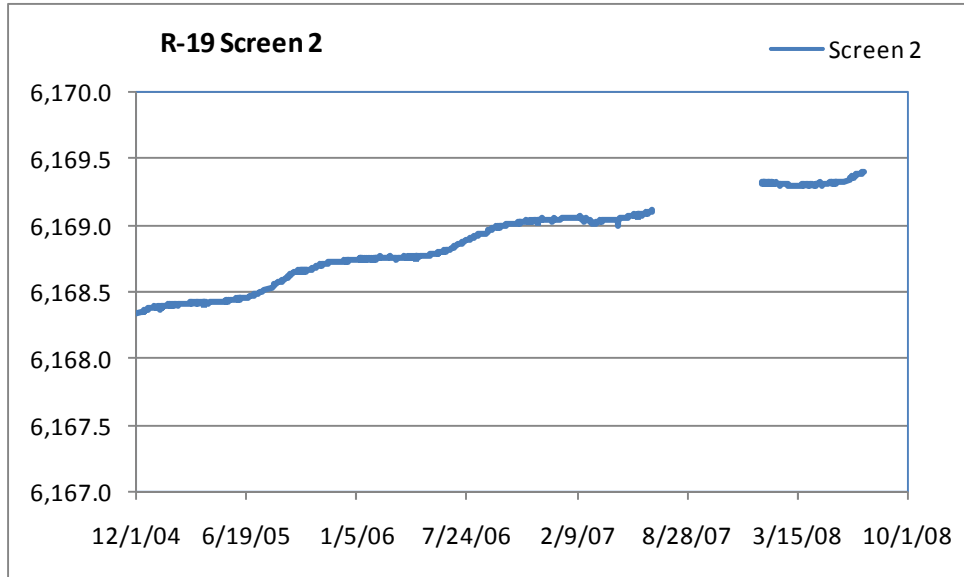

Figure L-7.0-1 Intermediate groundwater level at R-19 screen 2

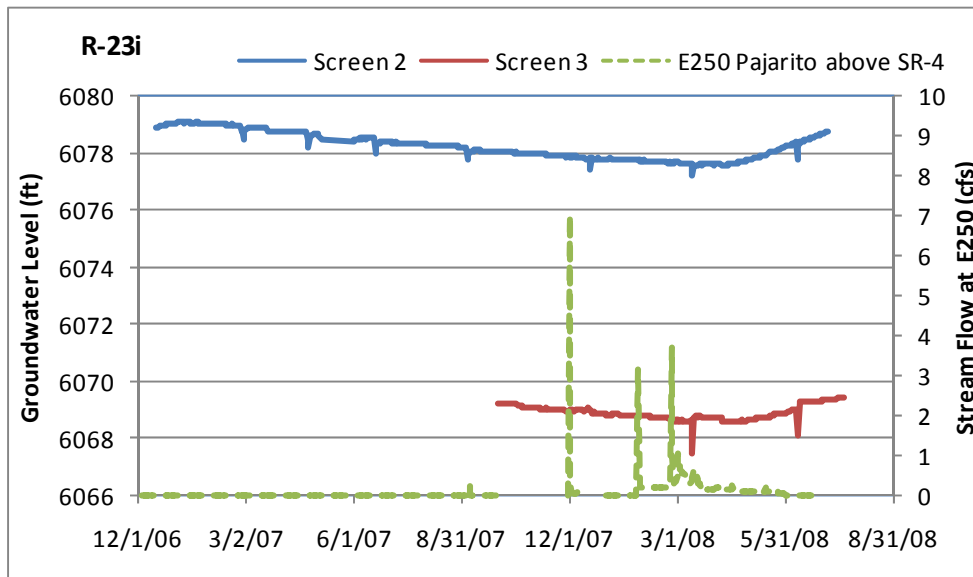

Figure L-7.0-2 Runoff at gage E250 in lower Pajarito Canyon and intermediate groundwater levels at R-23i

**Table L-2.0-1
Stream Gages in Pajarito Canyon**

Gage Number	Gage Name
E240	Pajarito below SR-501
E241	Pajarito above Starmer
E242	Starmer above Pajarito
E2425	La Delfe above Pajarito
E243	Pajarito above Twomile
E244	Twomile above Pajarito
E245	Pajarito above TA-18
E2455	Pajarito above Threemile
E246	Threemile above Pajarito
E250	Pajarito above SR-4

**Table L-2.0-2
Summary of Stream Flow in Pajarito Canyon 2006 to 2008**

Year	Ac-ft	E240	E241	E242	E2425	E243	E244	E245	E246	E250
2006	Snowmelt	0	1	7	3	0	0	0	0	0
	Storm	2	7	15	41	13	184	111	19	30
	Total	2	8	22	45	13	185	111	19	30
2007	Snowmelt	43	12	195	24	123	7	156	23	0
	Storm	5	10	284	101	16	80	143	2	16
	Total	48	22	479	124	139	87	298	25	16
2008	Snowmelt	1	5	165	11	241	14	110	21	50
	Storm	—*	—	—	—	—	—	—	—	—
	Total	—	—	—	—	—	—	—	—	—

* — = No data.

**Table L-3.0-1
Summary of Estimated Stream Gain/Loss in Pajarito Canyon Reaches 2006 to 2008**

Year	Ac-ft	Flow into Upper Pajarito Canyon	Flow above Twomile Canyon	Gain/Loss in Upper Pajarito Canyon	Flow into Middle Pajarito Canyon	Flow above TA-18 at E245	Gain/Loss in Middle PC	Flow into Lower Pajarito Canyon	Flow at E250 above SR-4	Gain/Loss in Lower Pajarito Canyon
2006	Snowmelt	11	0	-11	1	0	-1	0	0	0
	Storm	63	13	-51	197	111	-86	130	30	-99
	Total	74	13	-62	198	111	-87	130	30	-99
2007	Snowmelt	230	123	-107	130	156	26	179	0	-179
	Storm	395	16	-379	96	143	47	144	16	-129
	Total	625	139	-486	226	298	72	323	16	-308
2008	Snowmelt	181	241	60	256	110	-146	131	50	-81
	Storm	—*	—	—	—	—	—	—	—	—
	Total	—	—	—	—	—	—	—	—	—

Note: Calculated losses from stream gage data include ET losses.

* — = No data.

Table L-4.0-1
Summary of Well Completion Information for Alluvial Wells in Pajarito Canyon

Well Name	Surface Elevation (ft)	Depth Completed (ft bags)	Casing/ Screen Material	Top of Screen Depth (ft bags)	Bottom of Screen (ft bags)	Screen Length (ft)	Screen Top Elevation (ft)	Screen Bottom Elevation (ft)	Sump Length (ft)	Casing Inside Diameter (in.)	Screen Slot Size (in.)	Well Completion Date
18-BG-1	6776.5	35	PVC	10.0	35.0	25.0	6766.5	6741.5	0.0	2.0	0.01	08/01/94
18-BG-4	6768.0	6.5	PVC	2.5	6.5	4.0	6765.5	6761.5	0.0	4.0	0.01	02/18/98
18-MW-11	6740.1	47	PVC	27.0	47.0	20.0	6713.1	6693.1	0.0	2.0	0.01	08/11/94
18-MW-17	6695.2	22	PVC	12.0	22.0	10.0	6883.2	6673.2	0.0	2.0	0.01	08/01/95
18-MW-18	6654.7	23	PVC	12.5	23.0	10.5	6642.2	6631.7	0.0	2.0	0.01	07/31/95
18-MW-7	6755.5	30	PVC	10.0	30.0	20.0	6745.5	6725.5	0.0	2.0	0.01	07/06/94
18-MW-8	6747.8	38	PVC	8.0	38.0	30.0	6739.8	6709.8	0.0	2.0	0.01	08/04/94
18-MW-9	6732.9	21	PVC	6.0	21.0	25.0	6726.9	6711.9	0.0	2.0	0.01	07/21/94
3MAO-2	6759.4	30	PVC	14.7	24.7	10.0	6744.7	6734.7	5.3	4.0	0.01	06/04/08
PCAO-5	6943.3	30	PVC	14.7	24.7	10.0	6928.6	6918.6	5.3	4.0	0.01	05/03/08
PCAO-6	6921.4	20	PVC	8.0	15.0	7.0	6913.4	6906.4	5.0	4.0	0.01	05/05/08
PCAO-7a	6712.0	25	PVC	9.7	19.7	10.0	6702.3	6692.3	5.3	4.0	0.01	05/30/08
PCAO-7b1	6713.6	60	PVC	44.0	54.0	10.0	6669.6	6659.3	6.0	4.0	0.01	05/21/08
PCAO-7c	6714.6	25	PVC	9.7	19.7	10.0	6704.9	6694.0	5.3	4.0	0.01	05/16/08
PCAO-8	6584.5	25	PVC	9.7	19.7	10.0	6574.8	6564.8	5.3	4.0	0.01	06/02/08
PCAO-9	6558.6	21	PVC	6.0	16.0	10.0	6552.6	6542.6	5.0	4.0	0.01	06/12/08
PCO-1	6687.0	12	PVC	4.0	12.0	8.0	6683.0	6675.0	0.0	4.0	0.02	06/30/85
PCO-2	6618.3	9.5	PVC	15.	9.5	8.0	6616.8	6608.8	0.0	4.0	0.02	06/30/85
PCO-3	6546.3	17.7	PVC	5.7	17.7	12.0	6540.6	6528.6	0.0	4.0	0.02	06/30/85
TMO-1	6945.2	6.5	PVC	3.5	6.5	3.0	6941.7	6968.7	0.0	1.5	0.01	06/09/08

**Table L-4.0-2
Summary of Water Levels for Alluvial Wells in
Pajarito Canyon Since January 1, 2007**

Well Name	Max Water Level (Ft)	Min Water Level (ft)	Water Level Range (ft)	Comment
18-BG-1	6771.2	6748.3	22.9	
18-BG-4	6765.7	6760.6	5.0	Threemile Canyon
18-MW-11	6725.6	6702.0	23.6	
18-MW-17	6688.3	6678.4	9.9	
18-MW-18	6643.9	6642.0	1.9	
18-MW-8	6745.2	6736.9	8.3	Threemile Canyon
18-MW-9	6726.4	6719.3	7.1	
3MAO-2	6748.8	6734.6	14.2	Initial well development
PCAO-5	6936.9	6932.4	4.6	Initial well development
PCAO-6	0.0	0.0	0.0	Well dry
PCAO-7a	6703.1	6701.1	2.0	Initial well development
PCAO-7b1	0.0	0.0	0.0	Well dry
PCAO-7b2	6702.3	6699.8	2.6	Initial well development
PCAO-7c	6708.3	6704.0	4.3	Initial well development
PCAO-8	6575.2	6564.5	10.8	Initial well development
PCAO-9	6550.9	6550.9	0.1	Initial well development
PCAO-1	6687.0	6682.7	4.2	
PCAO-2	6614.3	6609.5	4.8	
PCAO-3	6546.0	6528.5	17.5	
TMO-1	0.0	0.0	0.0	Well dry

Appendix M

*Evaluation of Existing Monitoring Well Locations for the
Purpose of Detecting Potential Contaminants from the
Pajarito Canyon Watershed*

M-1.0 INTRODUCTION

This appendix describes an assessment of the regional monitoring well network with respect to its ability to detect contaminant plumes from potential contaminant sources within the Pajarito Canyon watershed. The network consists of the existing and soon-to-be-drilled regional monitoring wells.

Contaminant transport through the vadose zone is not explicitly considered in the applied numerical models. Instead, potential contaminants are assumed to migrate predominantly vertically from their original source locations before reaching the regional aquifer. Lateral spreading of the contaminants during their transport through the vadose zone is not taken into account. Thus, modeling of contaminant transport begins at the regional water table.

M-2.0 MONITORING WELL NETWORK EVALUATION

A major objective of the numerical simulations is to analyze flow and contaminant transport directions from specific locations in the regional aquifer beneath the Pajarito Canyon. Uncertainties in the flow directions are estimated as well. Through this analysis, monitoring wells network efficiency is evaluated.

Contaminant transport in the regional aquifer is modeled from 10 potential breakthrough locations (Figure M-2.0-1). The breakthrough areas at the regional aquifer are elongated along the length of the canyon to address potential linear recharge associated with surface-water or alluvial groundwater loss. Note that to make the analyses more comprehensive and to address potential uncertainties, the 10 potential breakthrough locations cover much of the length of the watershed. Subdivision into multiple breakthrough locations allows for better delineated analysis of monitoring network detection efficiencies. The simulated plumes migrate in the regional aquifer from these breakthrough locations. The analyses incorporate all the production wells on the Pajarito Plateau.

The site-scale model LGM2D (e.g., LANL 2008, 102910) is used for these analyses. Laterally, the model domain extends from the flanks of the Sierra de los Valles on the west to the Rio Grande on the east. The entire Laboratory lies within this domain, as do all of the Los Alamos County water-supply wells. The top of the model domain is defined by the shape of the regional water table. The computational grid is uniform (structured) with horizontal grid spacing of 25 m × 25 m (82 ft × 82 ft).

The explicit simulation of the phreatic zone in the numerical model generally requires a complex representation of both the saturated and unsaturated zones in a single three-dimensional numerical model. However, because the water-table elevations do not exhibit pronounced transients, and the flow directions in the phreatic zone are almost at steady state (LANL 2006, 094161), the development of such a complex model is not necessary in this case. A simpler approach is used to simulate contaminant transport in the shallow phreatic zone. It is assumed that the water-table gradients are known and defined by the water-table alternative map presented in Figure M-2.0-1. It also is assumed that limited vertical mixing of contaminants occurs below the phreatic zone, and therefore, the model is reduced to a relatively thin zone along the water table. As a result, the two-dimensional model becomes pseudo-three-dimensional, with a uniform thickness of 100 m (328 ft).

Flow directions and magnitudes that control contaminant transport in the aquifer are generally dictated by the shape of the regional water table (Freeze and Cherry 1979, 088742, Chapter 5; Vesselinov 2005, 090040). Transport velocities are a function of the hydraulic gradients and the permeability and porosity of the hydrostratigraphic units. Permeability and porosity values of the hydrostratigraphic units are uncertain and represented as random variables, as defined in Table M-2.0-1; probability distribution functions are presented in Figures M-2.0-2 and M-2.0-3. The permeability ranges are based on site-

specific field hydraulic tests reported in McLin (2006, 093670) and literature data (Freeze and Cherry 1979, 088742). The ranges of porosity values for the regional aquifer units are defined based on data from the literature (Freeze and Cherry 1979, 088742). The only site-specific data available are for the Cerros del Rio basalt (Tb 4) and Puye Fonglomerate (Tpf), and these data are considered in developing the distributions for those two units (Keating et al. 2001, 095399). The parameter ranges include high-permeability values and low-porosity values that are expected to occur in the case of fracture flow within massive basalts.

To represent the dispersion of the potential contaminant plumes, an axisymmetric form of the dispersion tensor is used (cf., Lichtner et al. 2002, 095397); the longitudinal and transverse dispersivities are defined to characterize the tensor. It is assumed that longitudinal and transverse dispersivities are random variables with statistical parameters presented in Table M-2.0-2. Site-specific data supporting these values are not available. Based on data from literature, the selected range of values is reasonable for the spatial scale of simulated contaminant transport (on the order of kilometers, (Neuman 1990, 090184) and the properties of the flow medium.

To estimate uncertainty in the model predictions, a Monte Carlo analysis is performed. A set of 1000 uncorrelated, equally probable random realizations are generated using a Latin Hypercube sampling technique with the software Crystal Ball. Each realization includes 26 random variables, representing various model parameters that include the permeability and the porosity of the hydrostratigraphic units and the longitudinal and transverse dispersivities. The units are assumed to be uniform, and the dispersivities are the same for all of the hydrostratigraphic units. Because the parameter range includes high-permeability values and low-porosity values characteristic of fracture flow, a fraction (about one-tenth) of the realizations simulate fast preferential flow paths. Therefore, the probability that potential contaminant plumes might be affected by fracture flow is accounted for.

The numerical simulation of contaminant transport in the regional aquifer is performed using random-walk particle-tracking techniques (Lichtner et al. 2002, 095397). For each realization, a series of particles are released within areas at the top of the regional aquifer within the 10 potential source areas, as shown in Figure M-2.0-1. The results consist of 1000 possible contaminant plume distributions in the regional aquifer for each of the 10 breakthrough windows. The number of particles is selected to be large enough for sufficient characterization of contaminant dispersion in the numerical model. The particles' movement is tracked through the model domain to estimate potential spatial migration of contaminants. The numerical simulations are performed using particle-tracking capabilities of FEHM (Zyvoloski et al. 1996, 054421) and specially developed codes for numerical convolution (PointConvolute, PlumeStat). The saturated-zone analyses are computationally intensive; the simulations were performed using the Laboratory's multiprocessor clusters. The code MPRUN is used, which efficiently executes a series of Monte Carlo runs in a parallel environment. Because of the independent nature of the individual Monte Carlo runs, the parallelization efficiency scales well with the number of applied processors.

The hydraulic gradients in the model are constrained based on the water-table map (Figure M-2.0-1). As a result, it is possible that the permeability variation in the 1000 stochastic runs might produce groundwater flow (Darcy) velocities that exceed ranges expected based on previous information about the total amount of water flowing through the regional aquifer. Groundwater velocity is equal to hydraulic gradient times permeability, but the velocity can also be computed by dividing the total groundwater flow rate by the flow area (Freeze and Cherry 1979, 088742, Chapter 5). However, the transport velocities simulated in the model are considered to be characteristic only of the fraction of the groundwater flow medium where a dominant portion of contaminant transport occurs. As a result, the total amount of groundwater flowing through the aquifer will be consistent with existing hydrogeological information.

Therefore, the simulations target potential uncertainties associated with contaminant transport velocities rather than groundwater flow velocities.

The shape of the water table presented in Figure M-2.0-1 is not expected to be affected by water-supply pumping that occurs at depth within the aquifer. However, the potential effects of pumping on contaminant transport are simulated by mimicking a cone of depression around each pumping well. (Note, however, that no such cones of depression are known to be present.) In the simulations, the node that represents a particular pumping well is assigned a low pressure head consistent with water levels measured during pumping, and it is assigned a much higher permeability than the surrounding medium. This yields a gradient toward the pumping well, and the extent of the gradient varies in size depending on the permeability of the surrounding medium for a given realization. The pumping-well node is also defined as a sink that removes particles from the simulation domain and counts them as arriving at the water-supply well. Thus, while the hydraulic effects of pumping are not explicitly stated in this model, the potential for pumping wells to capture potential contaminant particles is included.

In the numerical simulations, the spatial distribution of the hydrostratigraphic units is defined using the Laboratory fiscal year 2005 geologic framework model (GFM) (Cole et al. 2006, 095079). The properties of various hydrostratigraphic units are assumed to be spatially uniform. In reality, the aquifer is expected to be highly heterogeneous. As a result, the real contaminant plumes are expected to be more spatially heterogeneous than represented in the model. Spatial heterogeneity may affect the ability of any monitoring network to detect potential contaminant plumes, depending on the distance between the potential source locations and the monitoring wells as well as the properties of aquifer heterogeneity. In general, the impact of aquifer heterogeneity on the network efficiency decreases with an increase of the distance between the potential source locations and the monitoring wells and a decrease of the spatial dimensions of heterogeneity structures. Based on the existing knowledge about the aquifer heterogeneity of Puye formation and Santa Fe Group (lateral sizes on the order of tens of meters) and the distances between the potential source locations and the monitoring wells (on the order of hundreds of meters and more), it can be expected that the aquifer heterogeneity has a small effect on the estimated network efficiencies.

Simulated plumes are based on a unit concentration released at each of the two source areas. Therefore, the model produces concentrations relative to the original source concentration at monitoring and production wells. The movement of a nonsorbing conservative tracer is simulated. No analytical detection limit or regulatory limits are used in this analysis because the predicted concentrations are relative, not absolute concentrations. Therefore, the modeling results do not indicate whether any of the plumes are associated with concentrations that exceed regulatory standards or detection limits. However, the simulations yield information about flow directions and about relative magnitudes of concentrations at pumping and monitoring wells that can be used to define the efficiency of the network.

M-3.0 MONITORING METRICS

An efficient monitoring location must intercept a contaminant plume before arrival at the production wells or before crossing the Los Alamos National Laboratory (the Laboratory) boundary. There are a number of possible scenarios for each simulation (or plume).

- *Successful* detections are plumes that are detected at a monitoring well.
- *Successful protections* are plumes that are first detected at a monitoring well and after that reach, a production well or the Laboratory boundary.
- *Failed protections* are plumes that first reach a production well or the Laboratory boundary and then later arrive at a monitoring well.

- *Nondetects* are plumes that reach either a production well or the Laboratory boundary but are not detected by any monitoring well.
- *False-positive detections* are plumes that are detected by the monitoring wells but never reach either a production well or the Laboratory boundary.
- *Detected plumes* are plumes that arrive at the monitoring wells. They include successful detections and failed detections.
- *Plumes of concern* are plumes that reach either a production well or the Laboratory boundary. In the network-efficiency analysis, it is important to demonstrate that high percentage (above 95%) of the plumes of concern are detected by the monitoring network before they reach either a production well or the Laboratory boundary.

Finally, detection efficiency is computed as the number of detected plumes divided by the number of simulated plumes (1000 plumes). Protection efficiency is computed as the number of successful detections divided by the number of plumes of concern. (In general, the number of plumes of concern can be different for each potential source; here, however, all the plumes are of concern because all of them reach either a production well or the Laboratory boundary.)

To estimate successful protection, the model-predicted contaminant travel times from the source area to the monitoring wells are compared with travel times to the water-supply wells and the Laboratory boundary. If the contaminant arrives first at a monitoring well, it is considered that the monitoring well provides successful protection.

There are multiple approaches that can be applied to estimate the travel times to the wells. For example, they can be based on the (1) first-particle arrival, (2) peak-mass arrival, or (3) arrival of some fraction of the released contaminant mass. As described above, a particle-tracking technique is used to simulate contaminant transport. Arrival of the first particle in such simulations is sporadic and often not statistically significant. To resolve this problem, a test that compares the arrival times for the first 10% of the peak contaminant (relative) concentration arriving at the locations of interest was previously applied in similar network efficiency analyses (LANL 2007, 098548; LANL 2007, 099128). This approach allows for better definition of the rising limb of a breakthrough curve at a given location and proved to be a successful test for this assessment. However, the results presented in previous reports using this metric seem to be conservative. This is because the comparisons are performed only in terms of whether the travel times are faster or slower to the monitoring wells when compared, for example, with the production wells. To better assess the network efficiency, the analyses are expanded to estimate statistical significance of differences in the travel times. In this case, the number of particles detected by the wells and the variance in the particle-travel times are also considered. The statistical comparison is based on standard t-test, which takes into account statistical properties of the particle-travel times associated with the compared wells. A comprehensive review of the application of t-test and related equations is given by Ruxton (2006, 099109). In this case, if the particles' travel times to a given production well are statistically smaller with 95% confidence from the travel times to a given monitoring well, then it is considered that the monitoring well does not provide successful protection. This approach provides more adequate estimation of protection efficiency.

The major assumption of this approach is that the analyzed random variables (log-transformed particle travel times) are normally distributed. The probabilistic distributions of arrival times generated as realizations of particle tracking simulations are tested for normality and log-normality using the Lilliefors test (Henderson 2006, 100331) at the 95% confidence level. Log-normality is tested by log-transforming the arrival times. The test case considers a contaminant source, a monitoring well, and a boundary segment to be protected by the monitoring wells. The monitoring well and the boundary segment are

located downgradient from the source. The test problem is designed based on prior network efficiency work related to TA-54 (LANL 2007, 098548). The analyses are computationally intensive and are not feasible to perform for each network efficiency evaluation. However, since the network-efficiency analyses use equivalent parameter distributions, it is expected that the conclusions made below will be valid as well. The source area is rectangular with a size of about $80 \times 80 \text{ m}^2$. The distances from the source to the monitoring well and the boundary segment are approximately 600 and 800 m, respectively. The length of the boundary segment is about 150 m. In the test, 1522 particles are released evenly distributed within the source area. The particle movement through the aquifer is simulated using FEHM, and times of particle arrival at the monitoring well and the boundary segment are recorded. In total, 1000 realizations are simulated using the parameter ranges discussed in the report. The analysis resulted in 92.4% of the realizations passing the Lilliefors test for log normality for arrival times to the monitoring well. For the boundary segment, 70.9% passed for log-normality. The analysis also demonstrated that a small fraction of the distributions passed the normality test when the data is not log transformed. The plots in Figure M-3.0-1 present the empirical cumulative distribution function (ECDF) for one of the realizations (from a total of 1000), plotted along normal cumulative distribution functions (CDFs) for reference. Visual inspection of the data suggests that all four distributions do not substantially deviate from the theoretical normal curves. Nevertheless, the only population to pass the normality Lilliefors test is the log-transformed monitoring-well population, even though the log-transformed boundary-segment population appears to follow the normal CDF very closely. This is due to the fact that the boundary-segment population is much larger, with 1204 particles arriving at various times, compared with 234 for the monitoring-well population. The larger sample size makes it more difficult to accept the null hypothesis that the population could come from a normal distribution. Therefore, the assumption that the log-transformed travel times are normally distributed is justifiable.

M-4.0 RESULTS

The protection efficiency (%) of the regional monitoring network to detect potential plumes originating at all the 10 breakthrough windows before their arrival at production wells is shown in Table M-4.0-1. The monitoring network provides efficient protection for all the considered cases except for potential breakthrough windows P3, P4, P5, and P6 (Table M-4.0-1). Potential breakthrough window P3 may cause unacceptably high percentage of detections at PM-4, PM-5, and the Laboratory boundary before the monitoring network will detect the plumes. Potential breakthrough window P4 could also allow for potential contaminant arrival at PM-4 only that may not be detected in a timely manner. Potential breakthrough windows P5 and P6 could allow for potential contaminant arrival at PM-2 without timely detection. However, it is important to note that these results are highly dependent on the specific direction of the flow as defined by the regional water table. Significant potential exists that updates to the water-table map for key areas beneath the Pajarito watershed will be necessary, based on data derived from the current drilling projects in the vicinity of TA-54. For example, the preliminary water-level data from R-37 indicate that the water-table map in that area may be significantly different than currently depicted on existing maps. The new water-level data from the new regional monitoring wells should be incorporated into the water-table analysis before additional network efficiency analysis or decisions are made. In addition, the applied model assumes that the capture zone of the water-supply wells partially extends to the regional water table. Additional analyses of the capture zone of the water-supply wells near Pajarito Canyon are expected to constrain this conceptual uncertainty. These analyses will utilize the spinner test that was recently performed at PM-2 (Appendix K) and the new hydrogeologic information collected at R-40 and other new regional monitoring wells close by i.e., R-38, R-39, and R-41).

Table M-4.0-2 lists the percentage of the potential plumes that might be observed at the water-supply wells.

The detection efficiencies (probability of detection in %) of the individual monitoring wells as well as the entire regional monitoring network to detect potential plumes from each of the 10 breakthrough locations are shown in Table M-4.0-3. The table shows that the monitoring network provides detection efficiency above 95% for all potential source areas, except for p3.

M-5.0 REFERENCES

The following list includes all documents cited in this appendix. Parenthetical information following each reference provides the author(s), publication date, and ER ID number. This information is also included in text citations. ER ID numbers are assigned by the Environmental Programs Directorate's Records Processing Facility (RPF) and are used to locate the document at the RPF and, where applicable, in the master reference set.

Copies of the master reference set are maintained at the NMED Hazardous Waste Bureau; the U.S. Department of Energy—Los Alamos Site Office; the U.S. Environmental Protection Agency, Region 6; and the Directorate. The set was developed to ensure that the administrative authority has all material needed to review this document, and it is updated with every document submitted to the administrative authority. Documents previously submitted to the administrative authority are not included.

Cole, G., J.W. Carey, L. Burnette, and T. Miller, 2006. "The 2005 Three-Dimensional Geologic Model of the Pajarito Plateau," Los Alamos National Laboratory document LA-UR-06-3060, Los Alamos, New Mexico. (Cole et al. 2006, 095079)

Freeze, R.A., and J.A. Cherry, January 1979. *Groundwater*, Prentice-Hall, Inc., Englewood Cliffs, New Jersey. (Freeze and Cherry 1979, 088742)

Henderson, A.R., 2006. "Testing Experimental Data for Univariate Normality," *Clinica Chimica Acta*, Vol. 366, pp. 112-129. (Henderson 2006, 100331)

Keating, E.H., V.V. Vesselinov, Z. Lu, and E. Kwicklis, 2001. "Annual Report on Regional Aquifer Modeling and Data Analysis," Los Alamos National Laboratory document LA-UR-04-1420, Los Alamos, New Mexico. (Keating et al. 2001, 095399)

LANL (Los Alamos National Laboratory), October 2006. "Mortandad Canyon Investigation Report," Los Alamos National Laboratory document LA-UR-06-6752, Los Alamos, New Mexico. (LANL 2006, 094161)

LANL (Los Alamos National Laboratory), September 2007. "Mortandad Canyon Groundwater Monitoring Well Network Evaluation, Revision 1," Los Alamos National Laboratory document LA-UR-07-6435, Los Alamos, New Mexico. (LANL 2007, 099128)

LANL (Los Alamos National Laboratory), October 2007. "Technical Area 54 Well Evaluation and Network Recommendations, Revision 1," Los Alamos National Laboratory document LA-UR-07-6436, Los Alamos, New Mexico. (LANL 2007, 098548)

LANL (Los Alamos National Laboratory), September 2008. "Los Alamos National Laboratory Update on the Chromium Project, August 2008," Los Alamos National Laboratory document LA-UR-08-5584, Los Alamos, New Mexico. (LANL 2008, 102910)

Lichtner, P.C., S. Kelkar, and B. Robinson, August 17, 2002. "New Form of Dispersion Tensor for Axisymmetric Porous Media with Implementation in Particle Tracking," *Water Resources Research*, Vol. 38, No. 8, pp. 21-1–21-16. (Lichtner et al. 2002, 095397)

- McLin, S.G., May 2006. "A Catalog of Historical Aquifer Tests on Pajarito Plateau," Los Alamos National Laboratory document LA-UR-06-3789, Los Alamos, New Mexico. (McLin 2006, 093670)
- Neuman, S.P., August 1990. "Universal Scaling of Hydraulic Conductivities and Dispersivities in Geologic Media," *Water Resources Research*, Vol. 26, No. 8, pp. 1749-1758. (Neuman 1990, 090184)
- Ruxton, G.D., July 2006. "The Unequal Variance *t*-test is an Underused Alternative to Student's *t*-test and the Mann-Whitney *U* test," *Behavioral Ecology*, Vol. 17, pp. 688-690. (Ruxton 2006, 099109)
- Vesselinov, V.V., 2005. "An Alternative Conceptual Model of Groundwater Flow and Transport in Saturated Zone Beneath the Pajarito Plateau," Los Alamos National Laboratory document LA-UR-05-6741, Los Alamos, New Mexico. (Vesselinov 2005, 090040)
- Zyvoloski, G.A., B.A. Robinson, Z.V. Dash, and L.L. Trease, May 20, 1996. "Users Manual for the FEHMN Application," Rev. 1, Los Alamos National Laboratory document LA-UR-94-3788, Los Alamos, New Mexico. (Zyvoloski et al. 1996, 054421)

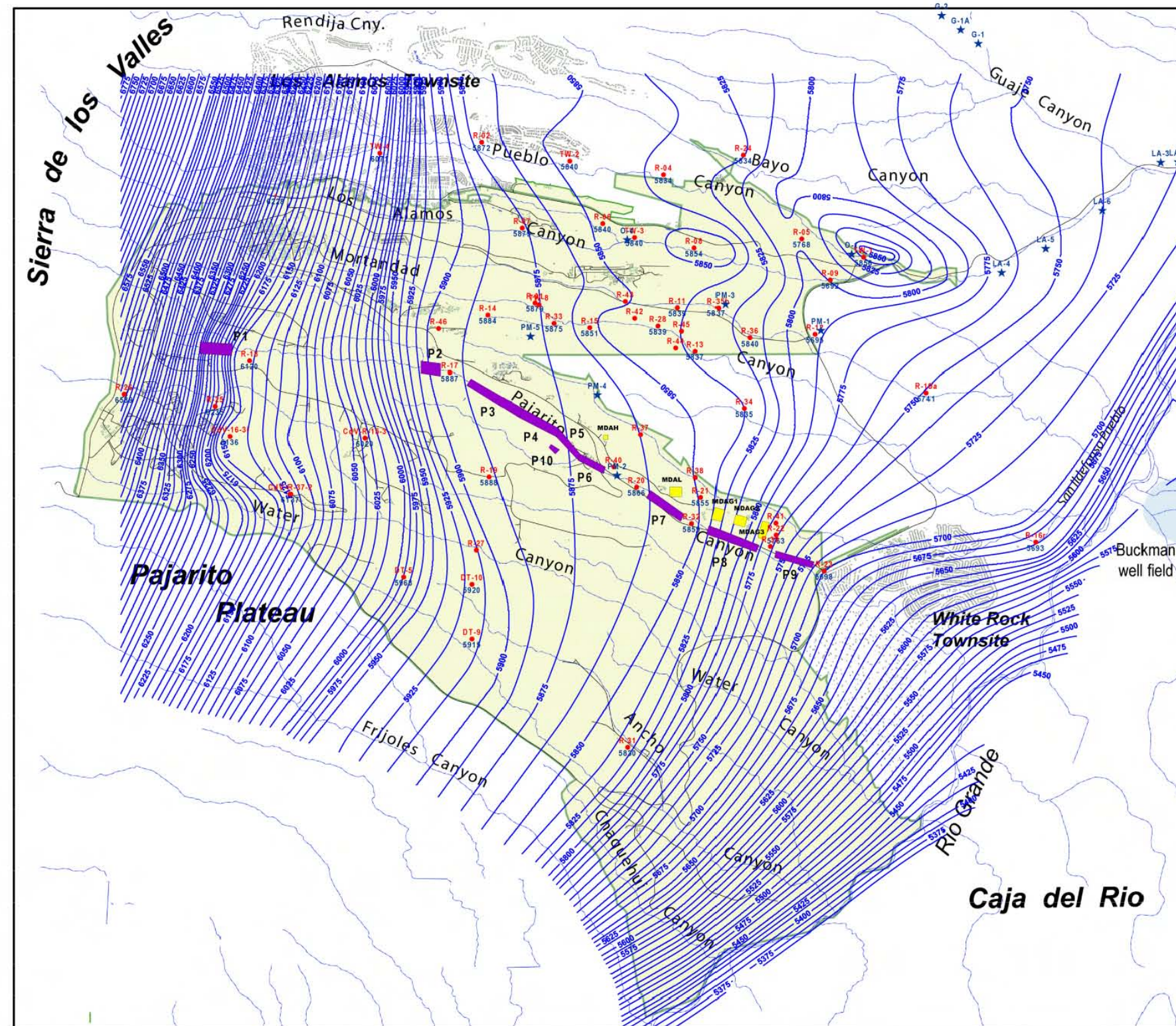
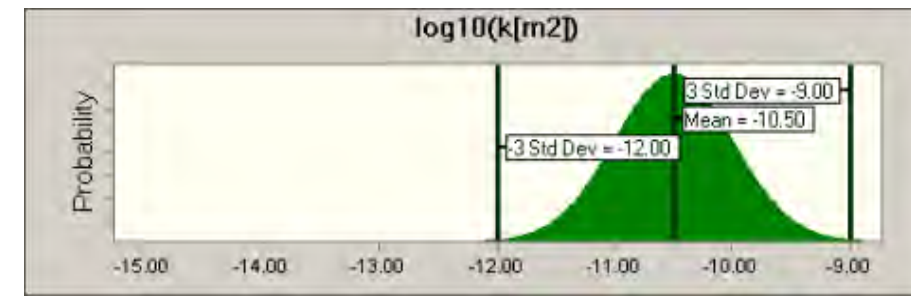
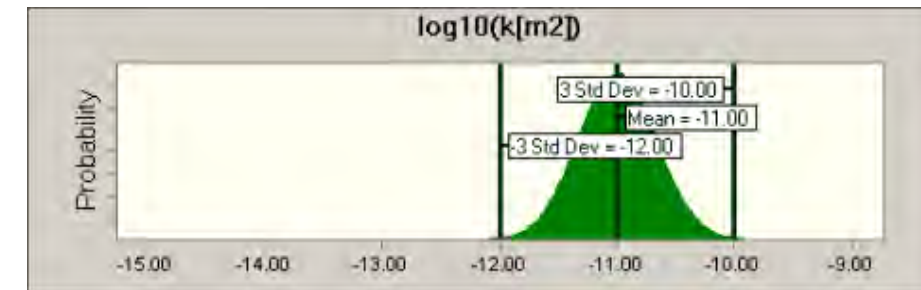

Figure M-2.0-1 Potential breakthrough windows along Pueblo Canyons (purple polygons). Regional monitoring wells are shown as red dots and productions wells are shown as blue stars. Contour lines show the elevation of the regional water table.



(a)



(b)

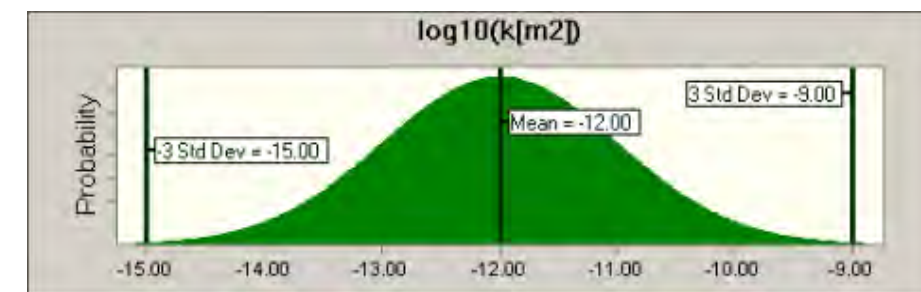

(c)

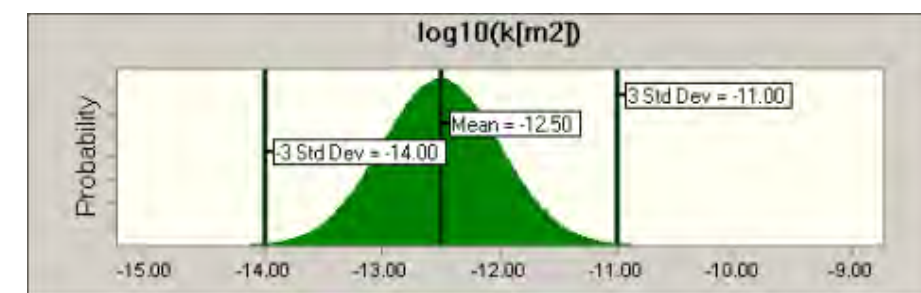

(d)

Figure M-2.0-2 Probability distributions of permeability for different hydrostratigraphic units: (a) Tschicoma, Keres group; (b) Totavi Lentil; (c) Cerros del Rio basalt, Bayo Canyon basalt; (d) pumiceous Puye, Puye fanglomerate, Santa Fe fanglomerate, and Santa Fe silt and sands

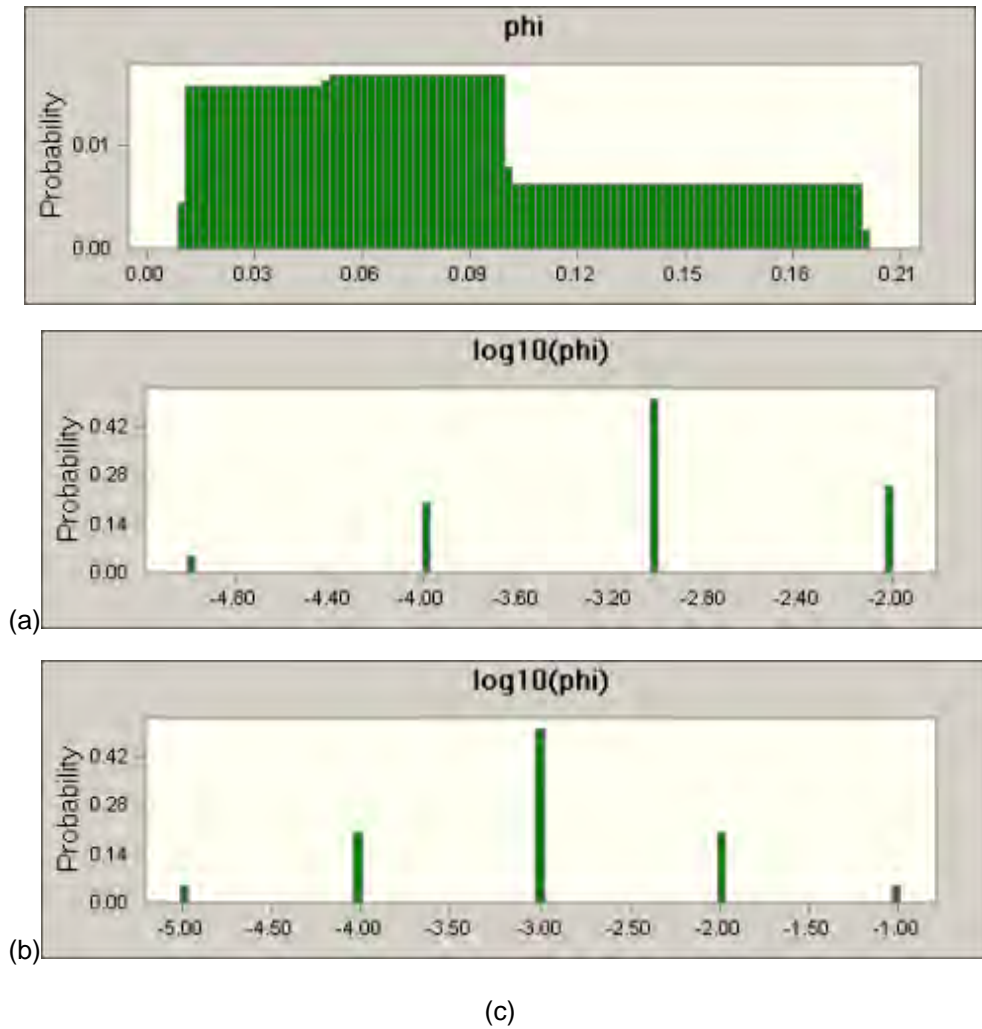

Figure M-2.0-3 Probability distributions of effective porosity for different hydrostratigraphic units: (a) Totavi Lentil, pumiceous Puye, Puye fanglomerate, Santa Fe fanglomerate, Santa Fe silt and sands; (b) Tschicoma, Keres group; and (c) Cerros del Rio basalt, Bayo Canyon basalt

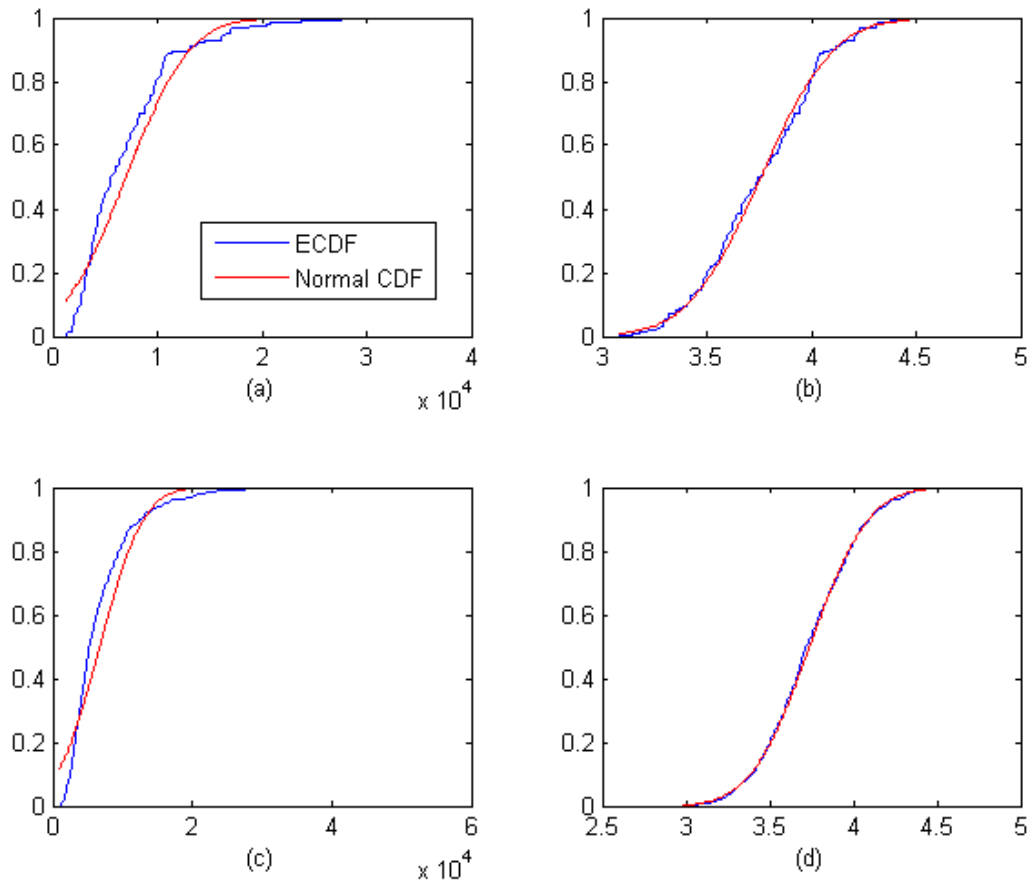

Figure M-3.0-1 ECDF for travel times to a monitoring well (a) and a boundary segment (c) for one of the realizations (from a total of 1000), plotted along the theoretical normal CDFs for reference. The log-transformed versions of the figures are plotted in (b) and (d) for the monitoring well and the boundary segment, respectively.

Table M-2.0.1
Characteristics of Hydrostratigraphic Units Represented in the Model

Unit	Name	Number of Nodes	Percentage in the Model	Permeability			Porosity		
				Distribution Type	Mean	Standard Deviation	Distribution Type	Min	Max
Tschicoma	Tt	73049	10.5%	Log normal	-10.5	0.50	Discrete	1.E-05	1.E-02
Keres Group	Tk	2865	0.4%	Log normal	-10.5	0.50	Discrete	1.E-05	1.E-02
Cerros del Rio Basalt	Tb4	97099	14.0%	Log normal	-12.0	1.00	Discrete	1.E-05	1.E-01
Bayo Canyon Basalt	Tb2	24007	3.5%	Log normal	-12.0	1.00	Discrete	1.E-05	1.E-01
Totavi Lentil	Tpt	22543	3.2%	Log normal	-11.0	0.33	Discrete	1.E-02	2.E-01
Pumiceous Puye	Tpp	29116	4.2%	Log normal	-12.5	0.50	Discrete	1.E-02	2.E-01
Puye Fanglomerate	Tpf	152808	22.0%	Log normal	-12.5	0.50	Discrete	1.E-02	2.E-01
Santa Fe Fanglomerate	Tf	78269	11.3%	Log normal	-12.5	0.50	Discrete	1.E-02	2.E-01
Santa Fe Silt and Sands	Ts	214192	30.9%	Log normal	-12.5	0.50	Discrete	1.E-02	2.E-01

Table M-2.0-2
Statistical Properties of Dispersivities

Parameter Name	Distribution Type	Min	Max
Longitudinal dispersivity	Uniform	50	300
Transverse dispersivity	Uniform	5	30

Table M-4.0-1
Protection Efficiency of the Production Wells of the Entire Network

Polygon Name	O-1	O-4	PM-1	PM-2	PM-3	PM-4	PM-5	Offsite
p1	100%	100%	100%	100%	100%	100%	100%	100%
p2	100%	100%	100%	100%	100%	100%	100%	100%
p3	100%	100%	100%	100%	100%	72%	71%	86%
p4	100%	100%	100%	97%	100%	54%	100%	96%
p5	100%	100%	100%	88%	100%	100%	100%	100%
p6	100%	100%	100%	85%	100%	100%	100%	100%
p7	100%	100%	100%	100%	100%	100%	100%	100%
p8	100%	100%	100%	100%	100%	100%	100%	100%
p9	100%	100%	100%	100%	100%	100%	100%	100%
p10	100%	100%	100%	100%	100%	100%	100%	100%

Note: Network efficiency values below 95% are marked in red.

**Table M-4.0-2
Percentage of Plume Detections at the Production Wells**

Polygon Name	O-1	O-4	PM-1	PM-2	PM-3	PM-4	PM-5
p1	1.7%	54.2%	41.1%	37.5%	96.0%	93.6%	100.0%
p2	0.4%	44.7%	43.5%	37.5%	100.0%	99.3%	100.0%
p3	2.0%	65.8%	90.9%	63.3%	100.0%	100.0%	100.0%
p4	0.1%	10.4%	100.0%	99.9%	99.7%	100.0%	44.6%
p5	0.2%	4.8%	100.0%	100.0%	100.0%	100.0%	1.1%
p6	0.0%	0.1%	35.3%	100.0%	10.8%	38.3%	0.1%
p7	0.0%	0.0%	5.2%	99.6%	0.9%	0.2%	0.0%
p8	0.0%	0.0%	0.1%	8.0%	0.0%	0.0%	0.0%
p9	0.0%	0.0%	0.1%	0.1%	0.0%	0.0%	0.0%
p10	0.0%	0.4%	100.0%	100.0%	95.1%	100.0%	0.0%

Table M-4.0-3
Detection Efficiency of Individual Monitoring Wells and the Entire Network
with Respect to Each of the 10 Assumed Breakthrough Locations

Monitoring Well	p1	p2	p3	p4	p5	p6	p7	p8	p9	p10
CdV-R-15-3	42.9%	26.1%	30.1%	0.6%	0.0%	0.1%	0.0%	0.0%	0.0%	0.0%
R-14	79.2%	54.7%	5.8%	0.1%	0.0%	0.0%	0.0%	0.0%	0.0%	0.0%
R-17	100.0%	100.0%	74.0%	1.9%	0.0%	0.0%	0.0%	0.0%	0.0%	0.0%
R-18	100.0%	0.2%	0.0%	0.0%	0.0%	0.0%	0.0%	0.0%	0.0%	0.0%
R-19	10.9%	11.1%	17.7%	7.1%	20.3%	5.6%	0.0%	0.0%	0.0%	3.1%
R-20	0.0%	0.1%	0.1%	0.5%	11.3%	6.9%	84.9%	0.7%	4.1%	1.4%
R-21	0.0%	0.0%	0.0%	0.3%	1.3%	0.0%	100.0%	38.9%	82.8%	0.0%
R-22	0.2%	0.3%	0.3%	1.9%	5.9%	0.8%	100.0%	100.0%	100.0%	0.8%
R-23	0.5%	0.3%	0.6%	7.5%	27.1%	1.2%	100.0%	100.0%	0.0%	5.2%
R-25	48.6%	0.0%	0.0%	0.0%	0.0%	0.0%	0.0%	0.0%	0.0%	0.0%
R-32	0.0%	0.0%	0.1%	0.1%	0.1%	0.1%	100.0%	85.7%	10.4%	0.2%
R-37	4.0%	4.4%	16.8%	93.2%	100.0%	14.7%	1.0%	0.0%	0.0%	95.3%
R-38	0.0%	0.0%	0.4%	0.5%	5.9%	0.0%	100.0%	3.5%	0.0%	0.4%
R-39	0.2%	0.2%	0.1%	0.9%	1.9%	0.1%	100.0%	100.0%	99.6%	0.1%
R-40	19.3%	17.8%	39.9%	97.2%	100.0%	100.0%	12.3%	0.0%	0.0%	100.0%
R-41	0.1%	0.0%	0.1%	5.4%	11.8%	0.9%	100.0%	87.5%	60.7%	1.2%
R-46	100.0%	86.3%	38.1%	0.4%	0.0%	0.0%	0.0%	0.0%	0.0%	0.0%
Entire network	100.0%	100.0%	85.0%	98.1%	100.0%	100.0%	100.0%	100.0%	100.0%	100.0%

Notes: The analysis is based on 1000 simulated plumes. Otherwise, detection efficiency values in blue range between 95% and 100%. For individual monitoring wells, values in green range between 50% and 94.9%, and values in black are less than 50%.

Appendix N

Direct Current Resistivity Survey in Pajarito Canyon

N-1.0 INTRODUCTION

Use of direct current (DC) resistivity in hydrogeologic investigations assumes that an important or dominant control on subsurface electrical resistivity is the presence and composition of groundwater, but other important factors are the lithologic properties of subsurface rock units and the abundance of clay or possibly other hydrous minerals (Geophex 2006, 094047). There are abundant data from existing samples to show that the dominant hydrous mineral in both the alluvium and the underlying altered bedrock is smectite, with lesser amounts of kaolinite (LANL 2006, 094161). A previous study on the Pajarito Plateau (Baldrige et al. 2006, 094048) established that with the exception of specific clay-rich units, groundwater is the chief control on electrical resistivity.

A DC resistivity survey was conducted in Pajarito Canyon in 2006 by Geophex of Raleigh, North Carolina. The Pajarito Canyon survey was part of a larger effort that included DC resistivity surveys in Sandia, DP, Los Alamos, and Pueblo Canyons (Geophex 2006, 094047). The Pajarito Canyon resistivity surveys were conducted in the following areas: (1) upper Pajarito Canyon at the confluence with Twomile Canyon, (2) Twomile Canyon above the confluence with Pajarito Canyon, (3) lower Pajarito Canyon segment 1, east of Technical Area 18 (TA-18) and south of Pajarito Road, (4) lower Pajarito Canyon segment 2, north of Pajarito Road from the vicinity of well R-20 to the west end of TA-54, and (5) lower Pajarito Canyon segment 3, south of Pajarito Road from Material Disposal Area (MDA) G to NM 4. Figure N-1.0-1 shows the locations of the resistivity lines collected in Pajarito Canyon.

N-2.0 METHODOLOGY

Electrical resistivity is a physical property of rocks and soil that is controlled by rock type, clay mineral content, porosity, and the quantity and quality of the water contained in the rock or soil. Within a given rock or soil type, the resistivity of the rock is primarily dependent on the quality and quantity of water and the amount of clay minerals. Generally, higher clay content and/or poorer quality (higher total dissolved solids and/or chlorides) in groundwater lowers the resistivity.

The electrical resistivity surveys conducted by Geophex were of the dipole-dipole configuration. Spacing between detector (inner) electrodes was fixed (19.6 ft), and spacing between electric-source (outer) electrodes along the survey line varied, depending primarily on the length of level ground available. The DC resistivity method measures the resistivity of the earth by introducing a near-DC signal into the ground (between the source electrodes) and measuring the resulting electric current created in the earth (between the detector electrodes). From these data the electrical properties of the earth can be derived and thereby the geologic and hydrologic properties inferred. The depth of investigation is a function of the length of the survey line, and the resolution is a function of the spacing between electric-source electrodes. The greater the spacing, the deeper the electrical currents will flow in the earth, hence the greater the depth of exploration. The depth of investigation is generally 20% to 40% of the electric-source (outer) electrode spacing, depending on the earth resistivity structure. The lower resistivity of the shallow units, the shallower is the investigation depth. The resistivity data are used to create a hypothetical model of the resistivity structure of the earth (geoelectric sections).

Resistivity models are generally not unique; that is, several resistivity models can produce the same observed data. In general, resistivity methods determine whether a given stratigraphic layer or unit is conductive or not. The conductance is the product of the resistivity and the thickness of a unit. Hence, that layer could be thinner and more conductive or thicker and less conductive and

produce essentially the same results. Borehole data and geologic conceptual models are used to constrain the geologic identity of the geoelectric units.

N-3.0 RESULTS

Upper Pajarito Canyon at the Confluence with Twomile Canyon (length 1771.1 ft)

Electrical resistivity in the shallow vadose zone (uppermost 225 ft) in middle Pajarito Canyon at the confluence with Twomile Canyon ranges from <18 to >1880 Ω -m (Figure N-3.0-1). The resistivity data roughly define two separate regimes. The upper part of the profile near the canyon floor is more conductive (<18 Ω -m to about 200 Ω -m) than deeper bedrock units of the Bandelier Tuff (200 Ω -m to >1880 Ω -m). The more conductive zone along the canyon floor thickens eastward, possibly reflecting the transition from a bedrock channel cut into welded tuffs of Qbt 2 at the west end of the profile to thickening alluvial deposits over porous, nonwelded tuffs of Qbt 1v at the east end. The new alluvial well PCAO-5 was installed in this area (Figure N-1.0-1) and penetrated 25 ft of alluvium before entering bedrock. The water level in the completed well was at a depth of 5 ft; this is consistent with the interpretation that shallow zone of greater conductivity in this part of the canyon represents enhanced moisture contents.

The most conductive area in the profile is a small zone at a depth of 50 to 100 ft near the west end of the profile. This result is uncertain because the area is close to the section edge. Areas of moderate conductivity also occur in the deeper bedrock from 680 to 880 ft and from 1080 to 1220 ft distance along the profile. These deeper zones of enhanced conductivity are limited in extent and their origin and nature are not well understood.

Overall, middle Pajarito Canyon contains rocks that are more resistive than areas farther downcanyon, as discussed below. The resistive nature of the rocks suggests that infiltration of surface water into underlying bedrock units is relatively minor in this part of the canyon.

Canyon above the Confluence with Pajarito Canyon (length 1082.4 ft)

The bedrock beneath Twomile Canyon above the confluence with Pajarito Canyon is more resistive than the adjacent areas of Pajarito Canyon. Below a depth of about 50 ft, electrical resistivity is generally 500 Ω -m to >1800 Ω -m (Figure N-3.0-2). The upper part of the profile along the canyon floor is less resistive (100 Ω -m to about 300 Ω -m) than the deeper rocks; this less-resistive upper zone thickens southward toward the confluence with Pajarito Canyon. The resistive nature of this profile is consistent with the intermittent nature of surface-water flow and lack of thick alluvial deposits in this canyon. Newly installed well TMO-1 near the confluence with Pajarito Canyon was dry when drilled, consistent with generally low conductivity in this canyon. Deep infiltration of surface water into underlying bedrock units is probably relatively minor in Twomile Canyon.

Lower Pajarito Canyon Segment 1: East of TA-18 South of Pajarito Road (length 1771.1 ft)

Electrical resistivity in the shallow vadose zone beneath segment 1 of lower Pajarito Canyon ranges from <18 to >1880 Ω -m (Figure N-3.0-3). Like middle Pajarito and Twomile Canyons, the upper part of the resistivity profile near the canyon floor is more conductive (<18 Ω -m to about 200 Ω -m) than in deeper rock units. However, the most conductive zones generally occur at depths of 15 to 70 ft rather than at the surface. The most laterally persistent conductive zone is associated with a wetlands area at 410 to 1140 ft distance along the profile. This persistent conductive zone occurs within relatively thick alluvial deposits and in the immediately underlying

nonwelded tuffs of Tshirege subunit Qbt 1g. A deeper conductive zone is centered on the R-20 well (Figure N-3.0-3) and may reflect the effect of a stainless-steel well located within 20 ft of the resistivity survey line.

Newly installed alluvial well PCAO-7C, located at the west end of the profile (Figure N-3.0-3), penetrated the alluvium/bedrock contact at a depth of 58.1 ft and initially contained alluvial groundwater at a depth of 8 ft. This well has since gone dry and appears to respond to seasonal variations in surface-water flow (Appendix G). Alluvial well 18-MW-17, located near the east end of the profile (Figure N-3.0-3), penetrated 23.8 ft of alluvium without entering bedrock; this well displays seasonal variations in depth to water ranging from 6 to >16 ft (Appendix G). Well R-20, located next to 18-MW-17, fully penetrated the alluvium/bedrock contact at a depth of 68 ft, and it encountered alluvial groundwater at a depth of 17.2 ft.

Overall, segment 1 of lower Pajarito Canyon contains rocks that are more conductive than those in the upcanyon resistivity lines. The most conductive zones correlate with a wetland and with an area of thick alluvial deposits. These features suggest that surface water in the wetland drains into the underlying alluvium, collecting near the alluvium/bedrock contact. Locally, the recharge is sufficient to form alluvial groundwater. Moderate resistivity in the bedrock units beneath the wetland indicate that moisture contents may also be enhanced in the underlying bedrock tuffs. Although the profile is limited to a depth of 250 ft, the upper part of the Otowi Member is resistive (500 Ω -m to >1880 Ω -m) in the lowermost parts of the profile, suggesting relatively dry conditions.

Lower Pajarito Canyon Segment 2: North of Pajarito Road from Vicinity of Well R-20 to West End of TA-54 (length 5904 ft)

Electrical resistivity in the shallow vadose zone beneath segment 2 of lower Pajarito Canyon ranges from <18 to >1880 Ω -m (Figure N-3.0-4). Key features of the resistivity profile include (1) a laterally persistent zone of higher conductivity extending from the lower part of the canyon-floor alluvium into the underlying bedrock and (2) broad zones of higher conductivity within deeper stratigraphic units. These two regions of conductive rocks are generally separated by an irregular zone of resistive tuffs within Tshirege Member subunit Qbt 1g. In some areas, vertical fingers of more conductive rock appear to connect the upper and lower conductive zones (e.g., at distances of 1300 ft, 4550 ft, and 5300 ft along the profile).

The upper zone of laterally persistent high conductivity (<18 Ω -m to about 300 Ω -m) is thickest at the west end of the profile and thins eastward (Figure N-3.0-4). The thickest (50 to 75 ft) and most conductive part of this upper zone is associated in part with wetland areas at 150 to 1550 ft and at 2300 to 2800 ft distance along the profile. In the western part of the profile, this laterally persistent conductive zone occurs near the base of relatively thick alluvial deposits and in the immediately underlying nonwelded tuffs of Tshirege subunit Qbt 1g. Eastward, the conductive zone thins to <25 ft and appears to be confined to the alluvium. In parts of the profile, zones of high conductivity extend upward to the canyon floor, and in other parts the conductive zone is overlain by upper alluvial deposits that are relatively resistive. Alluvial well PCO-1, located at the west end of the profile (Figure N-3.0-4), is 12 ft deep, and it typically contains alluvial groundwater at depths of 1 to 6 ft (Appendix G). This well is in a wetland in which high conductivity extends from the canyon floor to a depth of about 25 ft. Alluvial well 18-MW-18, located near the center of the profile (Figure N-3.0-4), is 23 ft deep, and depth to alluvial groundwater is 12 to 13 ft (Appendix G). Saturation in this well seems to correspond to a 10-ft thick zone of high conductivity above the base of alluvium.

Deeper conductive zones in bedrock are centered at 1400, 2700, 3450, 3900, 4500, and 5300 ft distance along the profile (Figure N-3.0-4). At least two of these deeper zones are located beneath wetland areas (at 1400- and 2700-ft distance along the profile). Another zone is near well R-32 and may reflect the electrical effect of a stainless-steel well located within 100 ft of the resistivity survey line. Other deep conductive zones in the profile are not related in an obvious way to surface hydrologic features and do not correlate to specific stratigraphic units, and their origin is uncertain.

Overall, segment 2 of lower Pajarito Canyon is similar to segment 1 in that it contains rocks that are more conductive than those in the vicinity of the Pajarito/Two-mile Canyons confluence. Like segment 1, the most conductive zones correlate with wetland areas and with a laterally persistent zone associated with alluvium. These features suggest that surface water in the wetland drains into the underlying alluvium, accumulating near the alluvium/bedrock contact. These wetland areas may act as storage for water recharging the alluvial aquifer in areas downcanyon from the wetlands. The occurrence of persistent water over a period of several years in alluvial wells PCO-1 and 18-MW-18 suggests the recharge to the alluvial aquifer is sufficient to maintain alluvial groundwater year-round in this part of the canyon. The extension of the high conductivity zone in the alluvium into tuffs beneath the westernmost wetland suggests that percolation of moisture into the underlying bedrock is enhanced in this area. Additionally, segment 2 contains a number of deep conductive zones within lower bedrock units that are not seen in upcanyon profiles. Although the origin of these zones is not well understood, their distribution and abundance in the segment 2 profile suggest that surface and alluvial groundwater is more likely to reach deeper parts of the vadose zone in this part of the canyon compared with upcanyon areas.

Lower Pajarito Canyon Segment 3: South of Pajarito Road from Vicinity of MDA G to NM 4 (length 7281.6 ft)

Electrical resistivity in the shallow vadose zone beneath segment 3 of lower Pajarito Canyon ranges from <18 to >1880 Ω -m (Figure N-3.0-5). The resistivity profile for this segment is generally similar to that for segment 2. It contains (1) a laterally persistent zone of higher conductivity in the lower part of the canyon-floor alluvium and (2) zones of higher conductivity within deeper stratigraphic units. These two regions of conductive rocks are generally separated by more resistive tuffs, and vertical fingers of more conductive rock connect the upper and lower conductive zones in many places along the profile.

An upper zone of laterally persistent high conductivity appears to be associated with the base of alluvium that is thickest at the west end of the profile and thins eastward (Figure N-3.0-5). Two thick conductivity zones are superimposed on the laterally persistent zones associated with the alluvium. Both of these thicker conductive zones coincide with wetland areas. The wetland located at 2900- to 4600-ft distance along the profile is associated with a high conductivity zone that is generally 25 to 50 ft thick. Several fingers of high conductivity appear to connect the wetland to deeper zones of high conductivity in the underlying Cerros del Rio basalt. Another wetland located 6600- to 7281-ft distance along the profile is associated with high conductivity zones that extend from the surface to depths of 50 to 100 ft. The alluvium and underlying Otowi Member tuff are very thin in this area, and the highly conductive zone includes the upper part of the Cerros del Rio basalt. A prominent vertical finger of high conductivity extends about 150 ft into the basalt at the western end of this wetland.

All three of the alluvial wells within segment 3 have well screens that coincide with the laterally persistent zone of higher conductivity in the lower part of the canyon-floor alluvium. Newly installed well PCAO-8, located in the western part of the profile (Figure N-3.0-5), contains alluvial groundwater at a depth of 9 ft, coinciding with the top of the conductive zone that is about 15 ft thick in the alluvial deposits. New well PCAO-9, located near the center of the profile (Figure N-3.0-5), encountered alluvial groundwater at a depth of 5 ft. Saturation in this well seems to correspond to a 15-ft thick zone of high conductivity above the base of alluvium. Well PCO-3, located in the eastern part of the profile (Figure N-3.0-5), was completed to a depth of 17.7 ft, and the water level generally occurs at a depth of 1 to 3 ft, although the water level fell below the bottom of the well screen (17.5 ft) during summer 2007. In the vicinity of PCO-3, the resistivity survey showed that high conductivity extends from the surface to a depth of about 30 ft.

In summary, segment 3 of lower Pajarito Canyon contains conductive zones that correlate well with wetland areas and with a laterally persistent zone near the base of alluvial deposits. In general, water levels measured in alluvial wells PCAO-8, PCAO-9, and PCO-3 correlate with the top of the zone of high conductivity within alluvium. This suggests the shallow zones of high conductivity in the alluvium are associated with saturated or near-saturated conditions. In PCO-3, water levels measured over a period of several years suggest that alluvial groundwater is persistent in this part of Pajarito Canyon. However, the drop in water level during summer 2007 demonstrates that the downcanyon extent of saturation may vary seasonally (Appendix G). The nature of the vertical fingers and deep zones of high conductivity are not fully understood, but their greater abundance in the segment 3 profile suggests that like segment 2, surface water and alluvial groundwater are more likely to reach deeper parts of the vadose zone in this part of the canyon compared with upcanyon areas.

At least two interpretations may apply to the deeper zones of enhanced conductivity in bedrock units. The fingers of greater electrical conductivity may represent preferred infiltration pathways, such as fault zones or regions of closely spaced fractures that focus the deeper penetration of near-surface water. Presence of clay minerals in fractures or faults would enhance the conductivity of these features. Regions of high resistivity between the fingers presumably contain fewer fractures or faults and are relatively dry. An alternative interpretation is that water in the subsurface occurs as pods, ribbons, or channels of wetter or possibly saturated sediments and/or rocks, which are interconnected laterally and vertically to form a three-dimensional network. The electrical-resistivity line thus alternately crossed regions of high and low resistivity. In addition, conductive regions lying close to but not beneath the line may "short circuit" electrical currents, the effect of which is to artificially map these higher-conductivity regions into the plane of the section. In these cases, the fingers of higher conductivity may be real but not necessarily correctly positioned with respect to the profile. The conductivity finger near TH-5 may be an example of this phenomenon. There are several ways to test these possibilities, the most direct of which would be to place electrodes in a two-dimensional array in areas of primary interest. Such an array could be left in place over a year or more to examine seasonal water retention in the shallow vadose zone and loss of water to the deeper vadose section.

N-4.0 REFERENCES

The following list includes all documents cited in this appendix. Parenthetical information following each reference provides the author(s), publication date, and ER ID number. This information is also included in text citations. ER ID numbers are assigned by the Environmental Programs Directorate's Records Processing Facility (RPF) and are used to locate the document at the RPF and, where applicable, in the master reference set.

Copies of the master reference set are maintained at the New Mexico Environment Department Hazardous Waste Bureau; the U.S. Department of Energy–Los Alamos Site Office; the U.S. Environmental Protection Agency, Region 6; and the Directorate. The set was developed to ensure that the administrative authority has all material needed to review this document, and it is updated with every document submitted to the administrative authority. Documents previously submitted to the administrative authority are not included.

Baldrige, W.S., G.L. Cole, B.A. Robinson, and G.R. Jiracek, 2006. "Application of Time-Domain Airborne Electromagnetic Induction to Hydrogeologic Investigations on the Pajarito Plateau, Los Alamos, New Mexico, USA." (Baldrige et al. 2006, 094048)

Geophex, January 2006. "DC Resistivity Profiling in DP, Los Alamos, Pajarito, Pueblo and Sandia Canyons, Los Alamos National Laboratory, Los Alamos, NM," report prepared for Los Alamos National Laboratory, Los Alamos, New Mexico. (Geophex 2006, 094047)

LANL (Los Alamos National Laboratory), October 2006. "Mortandad Canyon Investigation Report," Los Alamos National Laboratory document LA-UR-06-6752, Los Alamos, New Mexico. (LANL 2006, 094161)

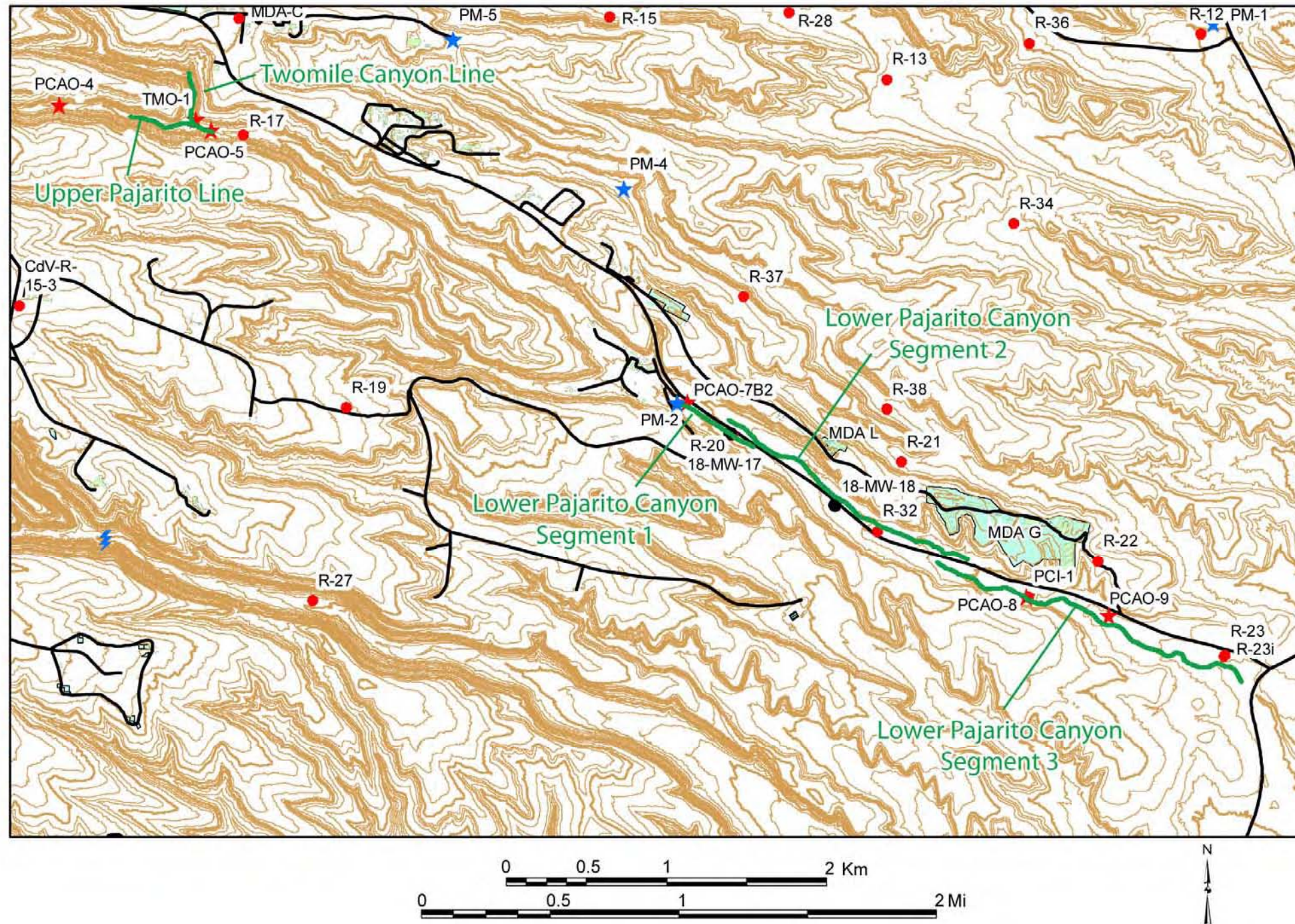

Figure N-1.0-1 Locations of DC resistivity survey lines in Pajarito Canyon

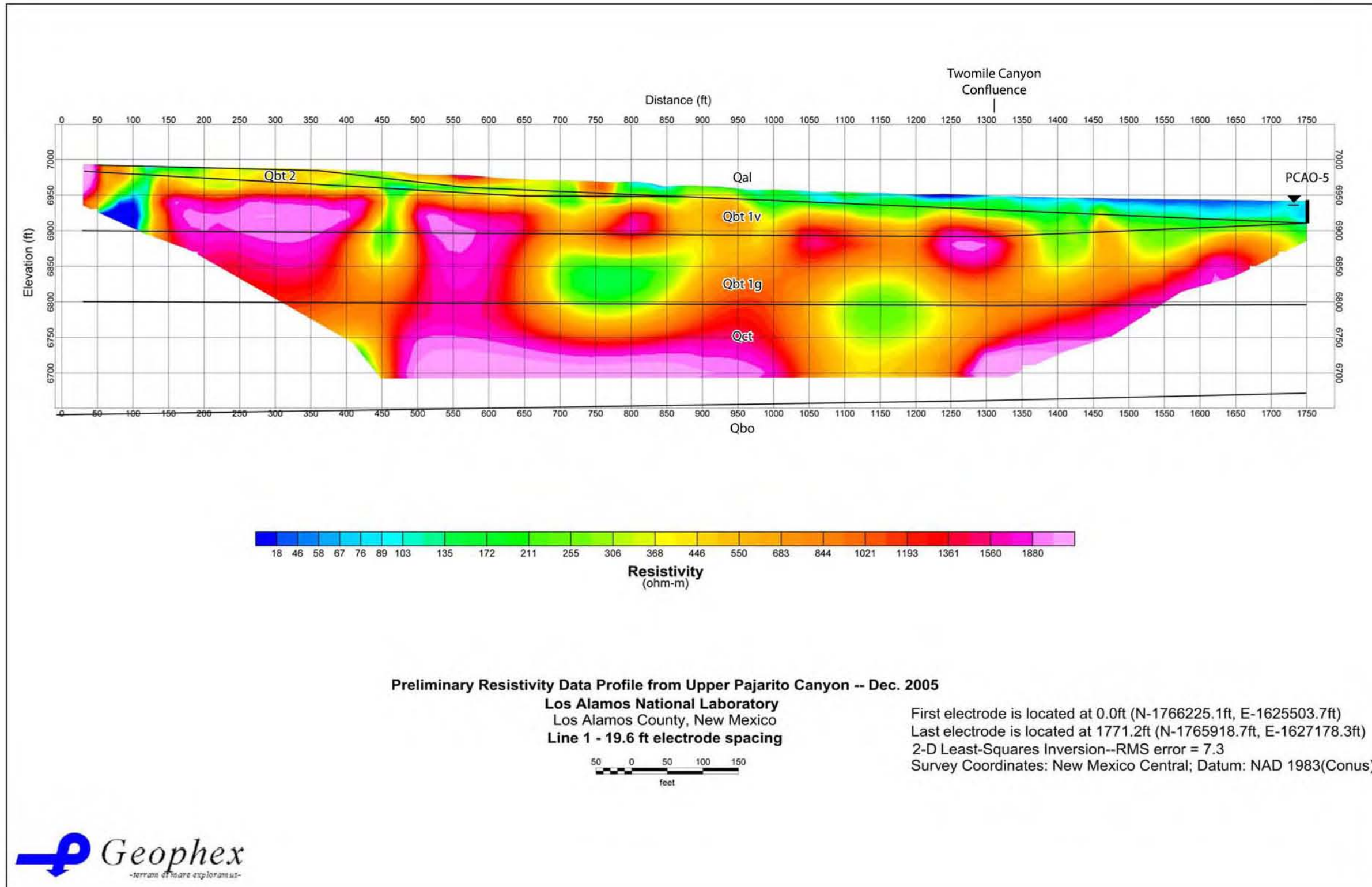

Figure N-3.0-1 DC resistivity profile for upper Pajarito Canyon at the confluence with Twomile Canyon

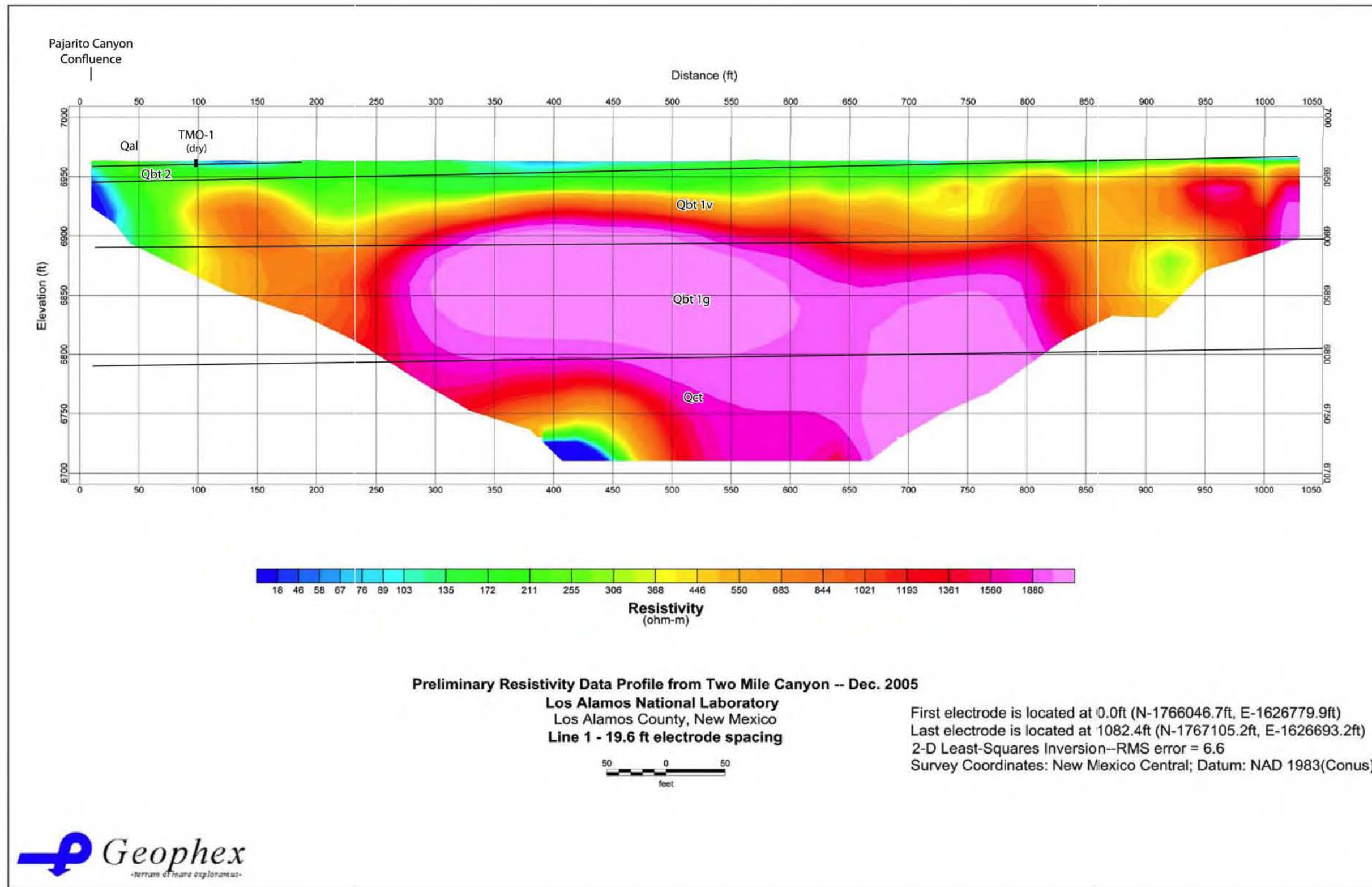

Figure N-3.0-2 DC resistivity profile for Twomile Canyon above the confluence with Pajarito Canyon

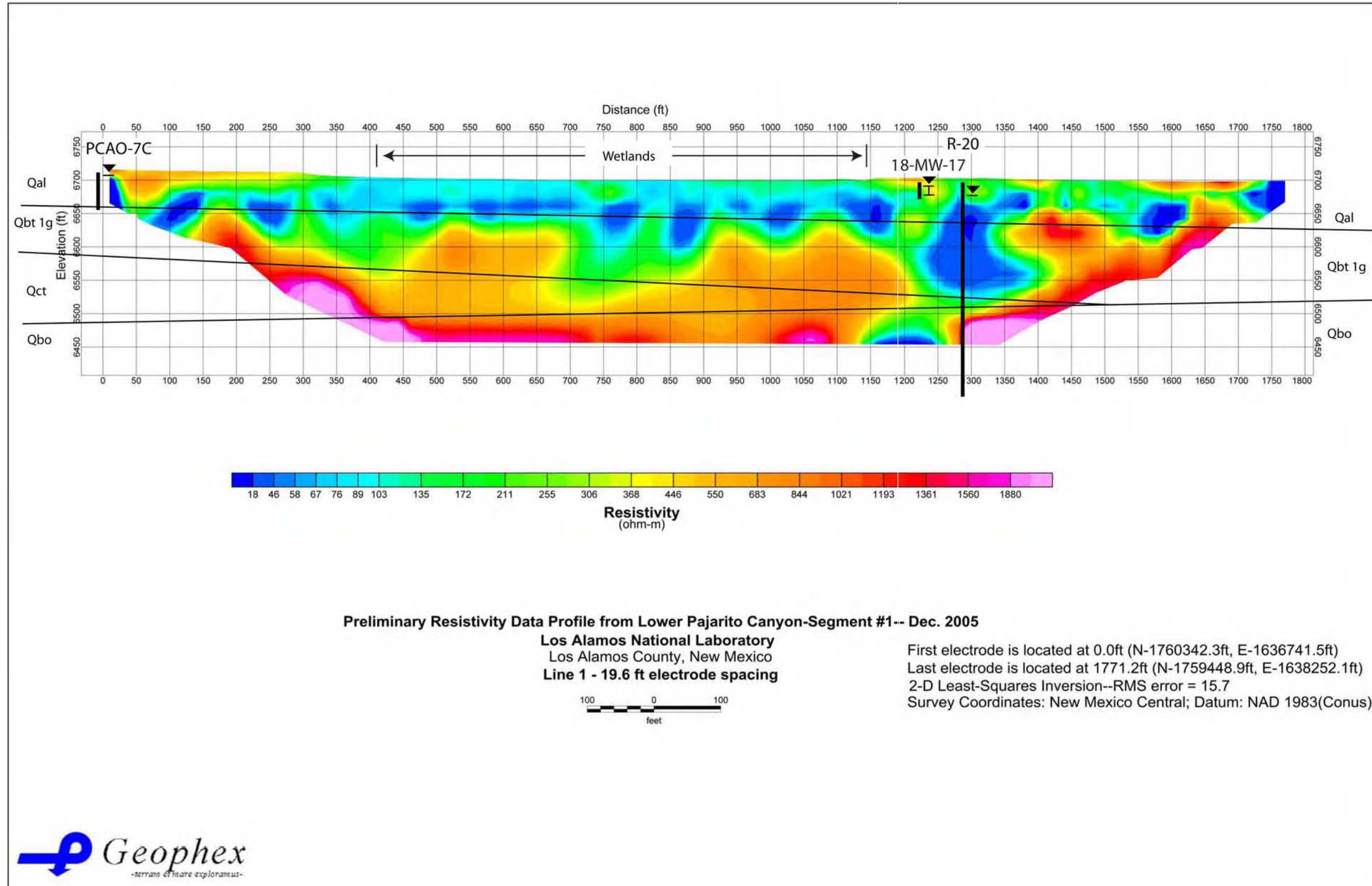

Figure N-3.0-3 DC resistivity profile for lower Pajarito Canyon segment 1 east of TA-18 and south of Pajarito Road

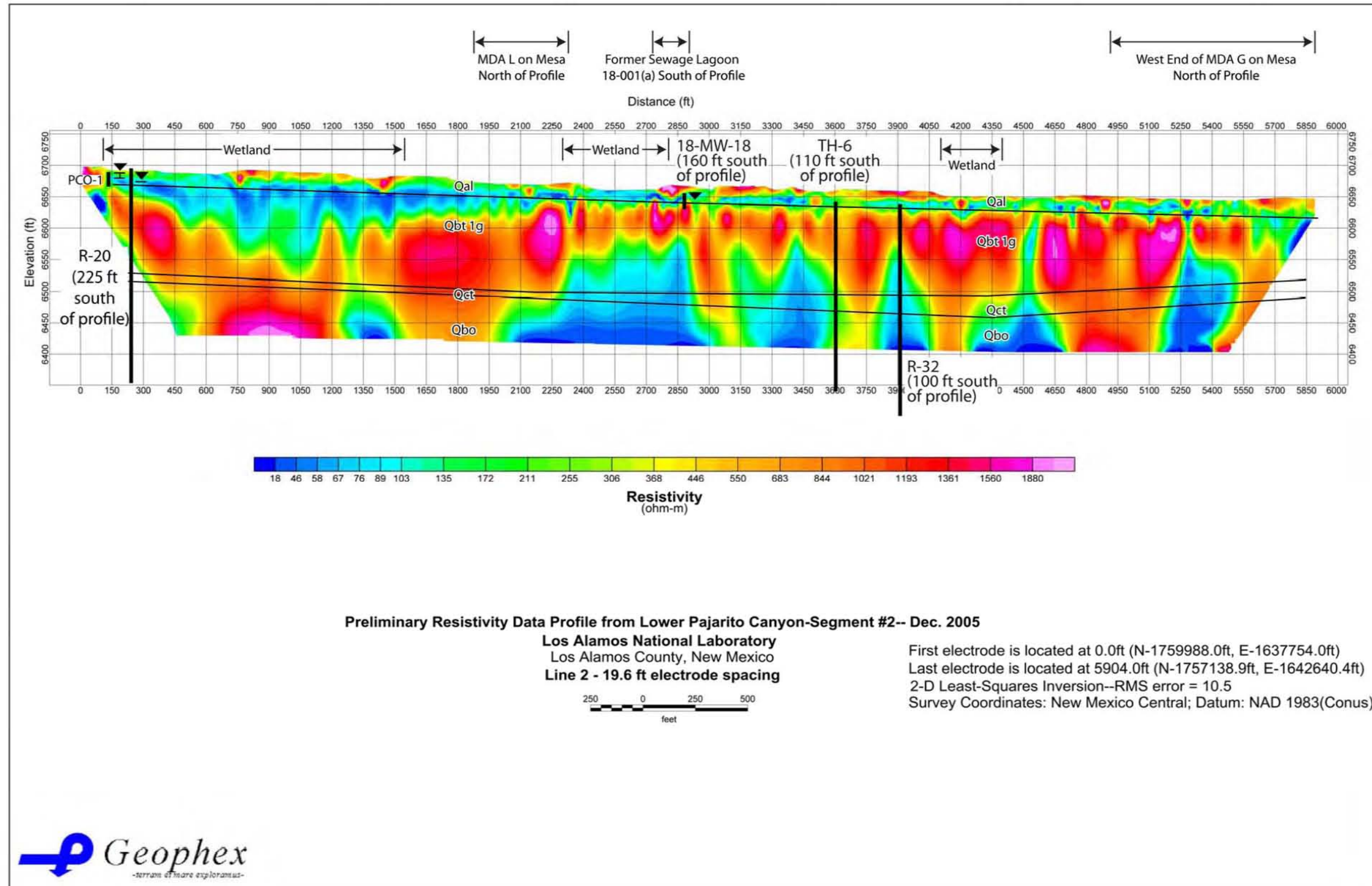

Figure N-3.0-4 DC resistivity profile for lower Pajarito Canyon segment 2 north of Pajarito Road from the vicinity of well R-20 to the west end of TA-54

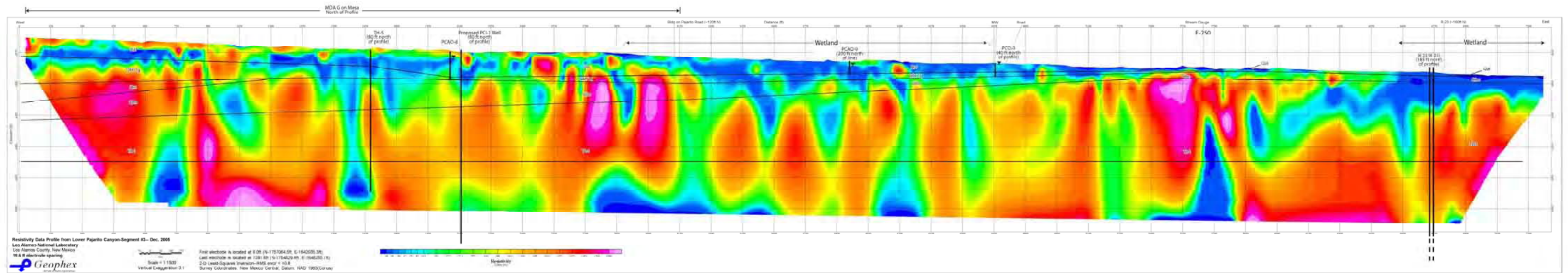

Figure N-3.0-5 DC resistivity profile for lower Pajarito Canyon segment 3 south of Pajarito Road from the vicinity of MDA G to NM 4

Attachment 1

*Environmental Restoration Database and
Water-Quality Database
(on DVDs included with this document)*

Attachment 2

*Environmental Restoration Database and Water-Quality Database Analytical Data; Hydrology, Geochemistry, and Geology Regional Well Core Leachate and Moisture Data; Sediment Particle-Size Data; Water-Level Data; Spinner Log Data; Nest Box Egg Measures; and Nest Box Success Measures
(on CD included with this document)*

